

---

## 4-channel digital audio system with FFX™ driver

---

### Features

- High efficiency FFX™ class-D modulator
- 100-dB dynamic range
- Two stereo channels with I<sup>2</sup>S input/output data interface
- 16-bit stereo ADC input with PGA and microphone biasing
- Analog and digital muxing/mixing capability
- 4-channel input sample rate converter (8 kHz to 192 kHz)
- Four channels of 24-bit audio processing
- Flexible channel mapping and routing
- Output configurations:
  - 2.0
  - 2.1
  - 4.0
  - Mono
- Embedded CMOS bridge: up to 0.5 W/channel
- pfStart™ for pop-free single-ended operations
- Play and record simultaneous operation
- Pre and post mix stages
- Individual channel and master gain/attenuation

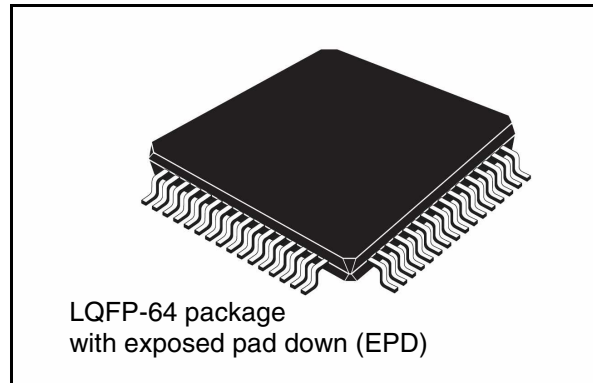

- Digital gain/attenuation -105 dB to +36 dB in 0.5-dB steps
- Soft volume update and muting
- DC-blocking selectable high-pass filter
- Selectable de-emphasis filter
- Up to 13 28-bit user programmable biquads (EQ) per channel
- Bass/treble tone control
- Ternary, binary or phase shift modulation
- PWM output
- Headphone output with jack detector
- I<sup>2</sup>C control.

**Table 1. Device summary**

Order code	Temperature range	Package	Packaging
STA321	0 to 70 °C	LQFP-64 EPD	Tray
STA321TR	0 to 70 °C	LQFP-64 EPD	Tape and reel

# Contents

- 1 Overview ..... 9**
- 2 Pin description ..... 10**
- 3 Electrical specifications ..... 13**
  - 3.1 Absolute maximum ratings ..... 13
  - 3.2 Recommended operating conditions ..... 13
  - 3.3 Electrical characteristics ..... 14
  - 3.4 Embedded crystal oscillator ..... 17
  - 3.5 Embedded DC regulator ..... 19
- 4 Power-up and power-down sequences ..... 20**
  - 4.1 Device power-up ..... 20
  - 4.2 Software power-down mode ..... 21
    - 4.2.1 Configuration example ..... 22
  - 4.3 Hardware power-down mode ..... 23
    - 4.3.1 Mild power-down ..... 25
    - 4.3.2 Full power-down ..... 27
- 5 Clock management ..... 29**
  - 5.1 System clock ..... 30
    - 5.1.1 Configuration example ..... 30
  - 5.2 Peripheral clock manager ..... 31
  - 5.3 Fractional PLL ..... 31
    - 5.3.1 PLL block description ..... 31
    - 5.3.2 Output frequency computation ..... 32
- 6 Digital processing stage ..... 34**
  - 6.1 Signal processing flow ..... 34
  - 6.2 Sampling rate converter ..... 35
  - 6.3 Pre-EQ mix 1 and post-EQ mix ..... 36
    - 6.3.1 Presets ..... 37
  - 6.4 Pre scaler ..... 37

6.4.1	Presets .....	37
6.5	Equalization, tone control and effects .....	37
6.6	Biquads .....	39
6.6.1	Presets .....	39
6.7	High-pass filter .....	39
6.8	Deemphasis filter .....	40
6.9	Bass and treble control .....	41
6.9.1	Configuration example .....	42
6.10	Programmable delay .....	42
6.10.1	Presets .....	42
6.11	Volume and mute control .....	42
6.12	Limiter (clamping) .....	43
6.13	FFX channel re-mapping .....	43
6.14	Memory programming .....	44
6.14.1	Writing one coefficient/location to RAM .....	44
6.14.2	Writing a set of five coefficients/locations to RAM .....	45
6.14.3	Reading a set of five coefficients/locations from RAM .....	46
6.14.4	RAM mapping .....	47
<b>7</b>	<b>FFX .....</b>	<b>52</b>
7.1	Functional description .....	52
7.2	Modulation schemes .....	52
7.3	PWM shift feature .....	55
7.4	Ternary mode .....	56
7.5	Minimum pulse limitation .....	56
7.6	Headphone modulation .....	57
7.7	pfStart™ operation .....	58
7.8	PWM00 output .....	59
<b>8</b>	<b>CMOS power stage .....</b>	<b>60</b>
<b>9</b>	<b>Fault detection and recovery .....</b>	<b>63</b>
9.1	External amplifier .....	63
9.2	CMOS bridge .....	63

<b>10</b>	<b>ADC</b> .....	<b>64</b>
	10.1 Description .....	64
	10.2 Application schematic .....	65
	10.2.1 Configuration example .....	65
<b>11</b>	<b>Serial audio interface</b> .....	<b>66</b>
	11.1 Master mode .....	66
	11.2 Slave mode .....	67
	11.3 Serial formats .....	68
	11.3.1 Right justified .....	68
	11.3.2 Left justified .....	68
	11.3.3 DSP .....	69
	11.3.4 I <sup>2</sup> S .....	69
	11.3.5 PCM/IF (non-delayed mode) .....	69
	11.3.6 PCM/IF (delayed mode) .....	70
	11.4 Invalid detection .....	71
<b>12</b>	<b>Headphone detection</b> .....	<b>72</b>
	12.1 Applications circuits .....	73
	12.2 Configuration example .....	74
<b>13</b>	<b>I<sup>2</sup>C interface</b> .....	<b>75</b>
	13.1 Communication protocol .....	75
	13.1.1 Data transition and change .....	75
	13.1.2 Start condition .....	75
	13.1.3 Stop condition .....	75
	13.1.4 Data input .....	75
	13.1.5 Device addressing .....	75
	13.1.6 Write operation .....	75
	13.1.7 Read operation .....	76
<b>14</b>	<b>Register description</b> .....	<b>77</b>
<b>15</b>	<b>I<sup>2</sup>C disabled (microless) mode</b> .....	<b>150</b>
<b>16</b>	<b>Package mechanical data</b> .....	<b>152</b>

17	<b>Glossary</b> .....	154
18	<b>Trademarks and other acknowledgements</b> .....	155
19	<b>Revision history</b> .....	156

## List of tables

Table 1.	Device summary . . . . .	1
Table 2.	Pin list . . . . .	10
Table 3.	Power supply pin list . . . . .	12
Table 4.	Absolute maximum ratings . . . . .	13
Table 5.	Recommended operating conditions . . . . .	13
Table 6.	Electrical specifications . . . . .	14
Table 7.	Oscillator specifications . . . . .	18
Table 8.	Power-up signal description . . . . .	20
Table 9.	Startup timings . . . . .	21
Table 10.	Configuration example . . . . .	21
Table 11.	Registers for power-down . . . . .	21
Table 12.	Example configurations for power-down . . . . .	22
Table 13.	Frequently used signals . . . . .	24
Table 14.	Clock control registers . . . . .	29
Table 15.	Clock characteristics . . . . .	30
Table 16.	Register setup to provide sys_clk from MCLK to PLL . . . . .	30
Table 17.	Input division factor (IDF) . . . . .	32
Table 18.	Loop division factor (LDF) . . . . .	33
Table 19.	Channel mapping . . . . .	36
Table 20.	EQ control signals . . . . .	38
Table 21.	Selecting EQ curves . . . . .	42
Table 22.	RAM mapping for processing stage . . . . .	47
Table 23.	Modulation type with register programming . . . . .	54
Table 24.	CMOS bridge signal descriptions . . . . .	60
Table 25.	Power output (at 1% THD) in headphone mode . . . . .	61
Table 26.	Logic circuit at bridge input . . . . .	62
Table 27.	Example register settings for ADC . . . . .	65
Table 28.	Timing parameters for master mode . . . . .	67
Table 29.	Timing parameters for slave mode . . . . .	67
Table 30.	Headphone 1 detector . . . . .	72
Table 31.	Headphone 2 detector . . . . .	72
Table 32.	Headphone detection configuration sequence for binary SE . . . . .	74
Table 33.	Headphone detection configuration sequence for binary headphone . . . . .	74
Table 34.	Register summary . . . . .	77
Table 35.	Bass/treble filter gains used in register addresses 0x78 - 0x7F . . . . .	115
Table 36.	LQFP-64L EPD dimensions . . . . .	153
Table 37.	Document revision history . . . . .	156

## List of figures

Figure 1.	STA321 block diagram	9
Figure 2.	Pin out	10
Figure 3.	Test circuit	17
Figure 4.	Oscillator configuration	17
Figure 5.	Equivalent circuit of crystal and external components	18
Figure 6.	Embedded DC regulator scheme	19
Figure 7.	Startup sequence	20
Figure 8.	Hardware power-done sequence	23
Figure 9.	Hardware powerdown sequence (mild mode)	26
Figure 10.	Hardware power-down sequence (full mode)	28
Figure 11.	Clock management scheme	29
Figure 12.	PLL block diagram	31
Figure 13.	Processing flow	34
Figure 14.	Processing data multiplexer	34
Figure 15.	SAI_out data multiplexer	35
Figure 16.	Sample rate converter block diagram	35
Figure 17.	Mixers block diagram	36
Figure 18.	EQ/tone block diagram	37
Figure 19.	Biquad coefficient selection	38
Figure 20.	Biquad filter	39
Figure 21.	High-pass filter frequency response	39
Figure 22.	Deemphasis filter frequency response	40
Figure 23.	Frequency responses of treble control at 1-dB gain steps	41
Figure 24.	Frequency responses of bass control at 1-dB gain steps	41
Figure 25.	FFX re-mapping	43
Figure 26.	Writing RAM location	44
Figure 27.	Writing five contiguous RAM locations	45
Figure 28.	Reading five contiguous RAM locations	46
Figure 29.	FFX processing schematic	52
Figure 30.	PWM modes for outputs A and B	53
Figure 31.	Modulation waveforms corresponding to <a href="#">Table 23</a>	54
Figure 32.	New phase shift modulation with shift feature	55
Figure 33.	Ternary modulation	56
Figure 34.	Modulation for headphones	57
Figure 35.	Digital pop-free ramp implementation	58
Figure 36.	CMOS half bridge block diagram	60
Figure 37.	Analog pop-free schematic	61
Figure 38.	Analog pop-free start-up and switch-off sequence	62
Figure 39.	ADC front-end block diagram	64
Figure 40.	Typical connections for power supplies and inputs	65
Figure 41.	SAI typical sampling rates	66
Figure 42.	Timing diagram for master mode	66
Figure 43.	Timing diagram for slave mode	67
Figure 44.	Right justified serial format	68
Figure 45.	Left justified serial format	68
Figure 46.	DSP serial format	69
Figure 47.	I <sup>2</sup> S serial format	69
Figure 48.	PCM (non-delayed) serial format	69

---

Figure 49.	PCM (delayed) serial format	70
Figure 50.	Invalid input detection schematic	71
Figure 51.	Headphone detection circuit for single-ended configuration	73
Figure 52.	Headphone detection circuit for binary HP configuration	73
Figure 53.	I <sup>2</sup> C write operations	76
Figure 54.	I <sup>2</sup> C read operations	76
Figure 55.	Microless mode block diagram	150
Figure 56.	LQFP-64L EPD outline drawing	152

# 1 Overview

The STA321 is a single chip solution for digital audio processing applications of up to 4.0 channels.

The STA321 is part of the Sound Terminal™ family that together with the digital power stage provides full digital audio streaming to the speaker, offering cost effectiveness, low energy dissipation and sound enrichment.

The STA321 input section consists of two multiplexed stereo analog inputs, a 16-bit ADC and two independent digital input interfaces. The serial audio data input interface accepts all possible formats, including the popular I<sup>2</sup>S format. There is also a digital output interface fed by the ADC or by the digitally processed signals.

The device has a full assortment of digital processing features. This includes sample rate converter, pre and post mixing, up to 13 programmable 28-bit biquads (EQ) per channel, bass/treble tone control and DRC. The embedded headphone detector indicates when headphone jack is inserted.

The STA321 provides four independent channels of FFX™ output capabilities. In conjunction with a power device, it provides high-quality, high-efficiency, all digital amplification.

The embedded CMOS bridge supplies up to 0.5 W into an 8-Ω load and 70 mW into a 16-Ω load for the headphones output.

**Figure 1. STA321 block diagram**

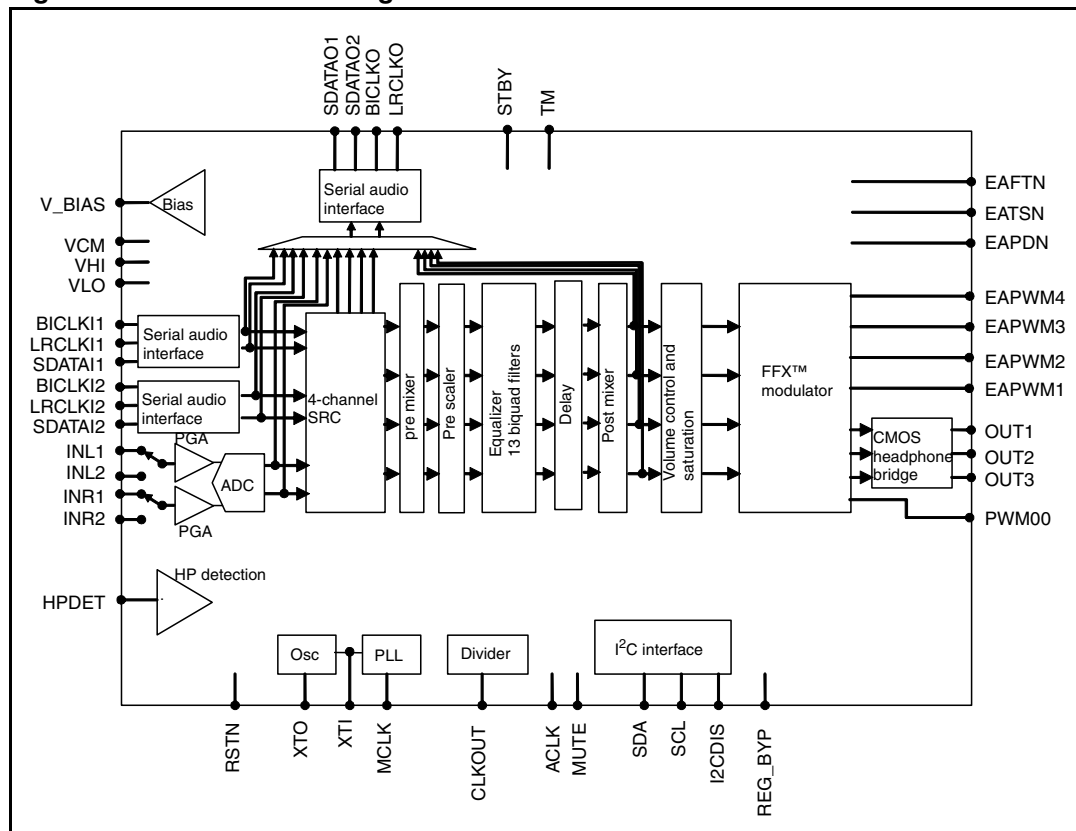

## 2 Pin description

Figure 2. Pin out

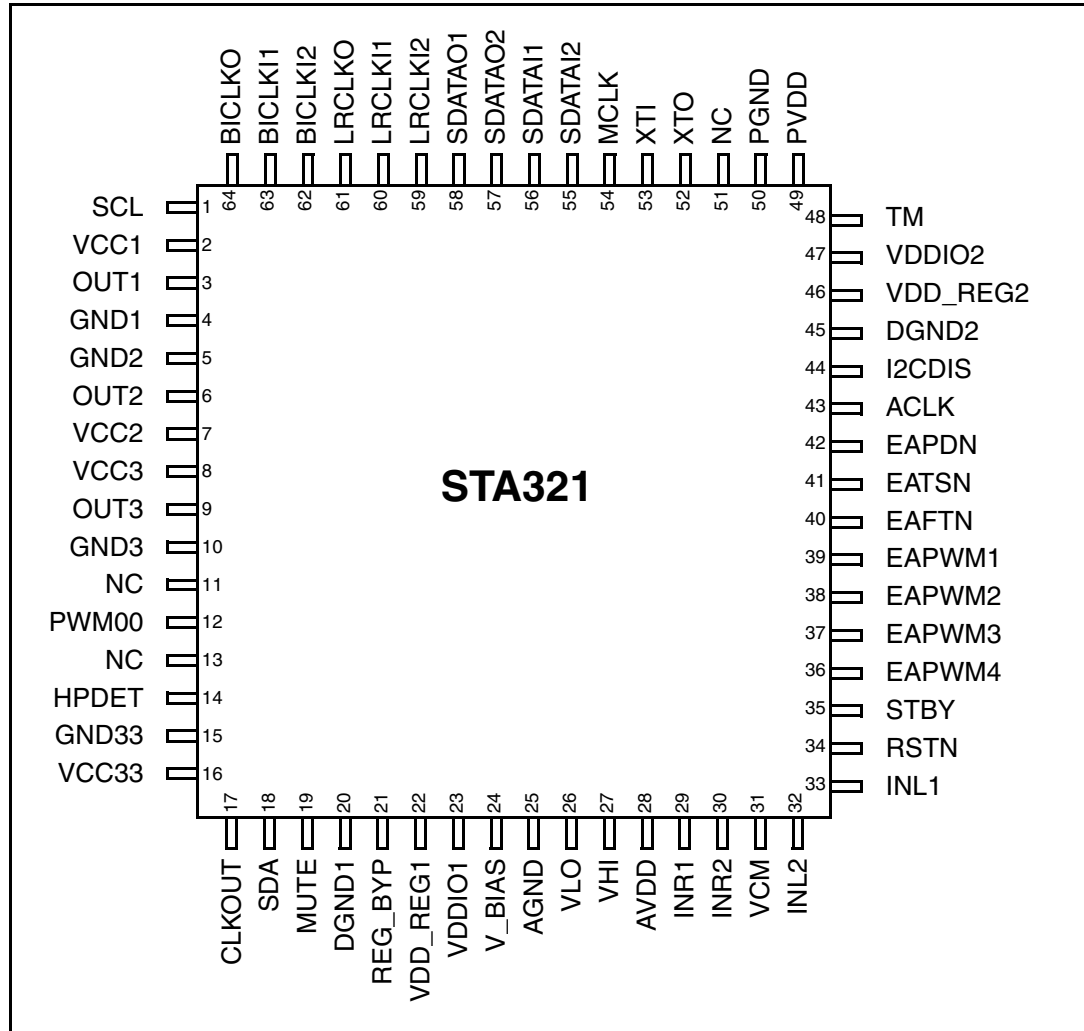

Table 2. Pin list

Pin	Pull	Name	Type	Description
1	-	SCL	In (digital), schmitt tr	I <sup>2</sup> C serial clock, schmitt trigger input
3	-	OUT1	Out (analog)	HP/line-out PWM 1
6	-	OUT2	Out (analog)	HP/line-out PWM 2
9	-	OUT3	Out (analog)	HP/line-out PWM 3
11	-	NC	-	Not connected
12	-	PWM00	Out (digital)	Auxiliary PWM
13	-	NC	-	Not connected
14	-	HPDET	In (analog)	Headphone detection

Table 2. Pin list (continued)

Pin	Pull	Name	Type	Description
17	-	CLKOUT	Out (digital)	Buffered clock output
18	-	SDA	In/Out (digital)	I <sup>2</sup> C serial data
19	H	MUTE	In (digital)	Mute (active high)
21	-	REG_BYPASS	In (analog)	DC regulator bypass: 0: normal operation, regulator enabled 1: regulator bypassed
24	-	BIAS	In/Out (analog)	ADC microphone bias voltage
26	-	VLO	In (analog)	ADC low reference voltage
27	-	VHI	In (analog)	ADC high reference voltage
29	-	INR1	In/Out (analog)	ADC right channel line input1
30	-	INR2	In/Out (analog)	ADC right channel line input2
31	-	VCM	In/Out (analog)	ADC common mode voltage
32	-	INL2	In (analog)	ADC left channel line input2 or microphone input2
33	-	INL1	In (analog)	ADC left channel line input1 or microphone input1
34	H	RSTN	In (digital)	Reset: 0: reset state 1: normal operation
35	-	STBY	In (digital)	Standby mode: 0: normal operation 1: power-down
36	-	EAPWM4	Out (digital)	External amplifier PWM 4B
37	-	EAPWM3	Out (digital)	External amplifier PWM 4A
38	-	EAPWM2	Out (digital)	External amplifier PWM 3B
39	-	EAPWM1	Out (digital)	External amplifier PWM 3A
40	H	EAFTN	Out (digital)	External power fault signal: 0: fault 1: normal operational mode
41	-	EATSN	Out (digital)	External amplifier control: 0: active 1: 3-state
42	-	EAPDN	Out (digital)	External amplifier powerdown (active low)
43	-	ACLK	In (digital), schmitt tr	Reserved pin, connect to ground
44	L	I2CDIS	In (digital)	I <sup>2</sup> C disable: 0: I <sup>2</sup> C enabled 1: I <sup>2</sup> C disabled
48	L	TM	In (digital)	Test mode: 0: normal operation
51	-	NC	-	Not connected

**Table 2. Pin list (continued)**

Pin	Pull	Name	Type	Description
52	-	XTO	Out (digital), 1.8 V	Crystal output
53	-	XTI	In (digital), 1.8 V	Crystal input or master clock input
54	-	MCLK	In (digital), schmitt tr	Master clock input 3.3-V compatible, schmitt input
55	-	SDATAI2	In (digital)	Input serial audio interface data
56	-	SDATAI1	In (digital)	Input serial audio interface data
57	-	SDATAO2	Out (digital)	Output serial audio interface data
58	-	SDATAO1	Out (digital)	Output serial audio interface data
59	-	LRCLKI2	In/Out (digital)	Input serial audio interface L/R-clock
60	-	LRCLKI1	In/Out (digital)	Input serial audio interface L/R-clock
61	-	LRCLKO	In/Out (digital)	Output serial audio interface L/R-clock (volume DOWN when I2CDIS=1)
62	-	BICKI2	In/Out (digital)	Input serial audio interface bit clock
63	-	BICKI1	In/Out (digital)	Input serial audio interface bit clock
64	-	BICKO	In/Out (digital)	Output serial audio interface bit clock (volume UP when I2CDIS=1)

**Table 3. Power supply pin list**

Number	Name	Type	Description
2	VCC1	Supply	CMOS bridge channel 1 supply
4	GND1	Ground	CMOS bridge channel 1 ground
5	GND2	Ground	CMOS bridge channel 2 ground
7	VCC2	Supply	CMOS bridge channel 2 supply
8	VCC3	Supply	CMOS bridge channel 3 supply
10	GND3	Ground	CMOS bridge channel 3 ground
15	GND33	Ground	CMOS bridge level shifter ground
16	VCC33	Supply	CMOS bridge level shifter supply
20	DGND1	Ground	Digital ground
22	VDD_REG1	Supply	DC regulator unit supply
23	VDDIO1	Supply	3.3-V IO supply
25	AGND	Ground	ADC analog ground
28	AVDD	Supply	ADC analog supply
45	DGND2	Ground	Digital ground
46	VDD_REG2	Supply	DC regulator unit supply
47	VDDIO2	Supply	3.3-V IO supply
49	PVDD	Supply	PLL analog supply
50	PGND	Ground	PLL analog ground

## 3 Electrical specifications

### 3.1 Absolute maximum ratings

**Table 4. Absolute maximum ratings**

Pin name/Symbol	Parameter	Negative	Positive	Unit
VDD_REG1, VDD_REG2	Digital supply voltage	-0.3	4.0	V
VDDIO1, VDDIO2	Digital IO supply voltage	-0.3	4.0	V
PVDD	PLL analog supply voltage	-0.3	4.0	V
AVDD	ADC analog supply voltage	-0.3	4.0	V
VCC1, VCC2, VCC3	CMOS bridge supply voltage	-0.3	4.0	V
VCC33	CMOS bridge level shifter power supply	-0.3	4.0	V
T <sub>STG</sub>	Storage temperature	-40	150	°C
T <sub>OP</sub>	Operating junction temperature	-20	125	°C

*Note:* All grounds must always be within 0.3 V of each other.

### 3.2 Recommended operating conditions

**Table 5. Recommended operating conditions**

Symbol	Parameter	Min	Typ	Max	Unit
V <sub>VDD_REG1</sub> , V <sub>VDD_REG2</sub>	Digital supply voltage	2.5	3.3	3.6	V
V <sub>PVDD</sub>	PLL analog supply voltage	2.5	3.3	3.6	V
V <sub>AVDD</sub>	ADC analog supply voltage	1.8	3.3	3.6	V
V <sub>VCC1</sub> , V <sub>VCC2</sub> , V <sub>VCC3</sub>	CMOS bridge supply voltage	1.55	-	3.3	V
V <sub>VCC33</sub>	CMOS bridge level shifter power supply. Ensure that V <sub>VCC33</sub> ≤ V <sub>VCCx</sub> always	1.55	-	3.3	V
V <sub>VDDIO1</sub> , V <sub>VDDIO2</sub>	3.3-V IO supply	2.7	3.3	3.6	V
V <sub>IH</sub>	High input voltage, 1.8-V pads	1.3	-	-	V
	High input voltage, 3.3-V pads	2.0	-	-	
V <sub>IL</sub>	Low input voltage, 1.8-V pads	-	-	0.6	V
	Low input voltage, 3.3-V pads	-	-	0.8	
T <sub>amb</sub>	Ambient temperature	0	-	70	°C

### 3.3 Electrical characteristics

Unless otherwise specified, the results in [Table 6](#) below are given for the operating conditions  $V_{CC} = 3.3\text{ V}$ ,  $R_L = 32\ \Omega$ ,  $f_{MCLK} = 12.288\text{ MHz}$ ,  $T_{amb} = 25\text{ }^\circ\text{C}$  and with the PLL set to default conditions.

**Table 6. Electrical specifications**

Symbol	Parameter	Test conditions	Min	Typ	Max	Unit
<b>General</b>						
$V_{OH}$	High output voltage, 1.8-V pads	-	1.4	-	-	V
	High output voltage, 3.3-V pads	-	$V_{VDDIO} - 0.15$	-	-	
$V_{OL}$	Low output voltage, 1.8-V pads	$I_{OL} = 2\text{ mA}$	-	-	0.15	V
	Low output voltage, 3.3-V pads	$I_{OL} = 2\text{ mA}$	-	-	0.15	
$V_{hys}$	Schmitt trigger hysteresis, 3.3-V IO	-	-	0.4	-	V
$R_{UP}$	Pull-up resistance	-	-	50	-	$k\Omega$
$R_{DN}$	Pull-down resistance	-	-	50	-	$k\Omega$
$I_{STBYIO}$	Standby current, pins VDDIO1,2	Pin STBY = 3.3 V CLKOUT disabled	-	450	-	$\mu\text{A}$
$I_{DDIO}$	Operating current, pins VDDIO1,2	-	-	3	-	mA
$I_{STBYL0}$	Standby current, pins VDD_REG1,2	Deep power-down, $V_{VDD\_REG1,2} = 3.3\text{ V}$	-	450	-	$\mu\text{A}$
$I_{STBYL1}$	Standby current, pins VDD_REG1,2	Mild power-down, $V_{VDD\_REG1,2} = 3.3\text{ V}$	-	2	-	mA
$I_{DDL1}$	Operating current, pins VDD_REG1,2	$f_{MCLK} = 12.288\text{ MHz}$ , Play from SAI to CMOS bridge and EAPWM, $f_{ADC} = 48\text{ kHz}$ on SAI_out, $V_{AVDD} = 3.3\text{ V}$ , $V_{VDD\_REG1,2} = 3.3\text{ V}$	-	45	-	mA
$I_{STBYPD}$	Pre-drive supply current in standby, pin VCC33	-	-	4.7	-	$\mu\text{A}$

Table 6. Electrical specifications (continued)

Symbol	Parameter	Test conditions		Min	Typ	Max	Unit
<b>Amplifier (CMOS bridge)</b>							
$\eta$	Output power efficiency	-		-	90	-	%
$P_{HP\text{OUT}}$	Output power in HP mode with THD = 1%	3.3-V supply	$R_L = 32 \Omega$	-	41	-	mW
	Output power in HP mode with THD = 10%	3.3-V supply	$R_L = 32 \Omega$	-	53	-	
SNR	Signal to noise ratio	20 Hz to 20 kHz		-	75	-	dB
THD + N	Total harmonic distortion plus noise	$R_L = 32 \Omega$ , HP mode	0 dBFs In	-	0.3	-	%
			-6 dBFs In	-	0.05	-	
DR	Dynamic range	A-weighted		-	80	-	dB
$I_{STBYP}$	Current in standby, pins VCCx	-		-	2	-	$\mu\text{A}$
$I_{DDP}$	Operating current, pins VCCx	No LC filter, no load, PWM at 50% duty-cycle		-	1	-	mA
$I_{DDPD}$	Pre-drive supply current in operation, pin VCC33	No load, PWM at 50% duty-cycle		-	250	350	$\mu\text{A}$
$t_R$	Driver rise time, pins OUT1-3	Resistive load, see <a href="#">Figure 3</a>		-	5	-	ns
$t_F$	Driver fall time, pins OUT1-3	Resistive load, see <a href="#">Figure 3</a>		-	5	-	ns
$R_{DSON}$	Headphone output stage N/P MOS on-resistance	-		-	500	700	$\text{m}\Omega$
$I_{OCH}$	Over-current limit for OUT1-3 to VCCx short circuit	-		-	1.88	-	A
$I_{OCL}$	Over-current limit for OUT1-3 to ground short circuit	-		-	1.72	-	A
<b>PLL</b>							
$I_{STDBYPLL}$	PLL supply current in standby	-		-	20	-	$\mu\text{A}$
$I_{DDPLL}$	PLL supply current in operation	-		-	0.4	1.0	mA
$f_{CLKIN\_Range}$	Input clock frequency range	-		2.048	-	49.152	MHz
Duty <sub>CLKIN</sub>	Input clock duty cycle	-		40	-	60	%
$t_{CLKIN\_RF}$	Input clock rise/fall time	-		-	-	0.2	ns
$f_{F\_INT}$	PFD input clock frequency	PLL_FR_CTRL = 1		2.048	-	12.288	MHz
$f_{VCO\_Range}$	Clock out range	-		65.536	-	98.304	MHz
Duty <sub>VCO</sub>	Clock out duty cycle	-		35	-	65	%
$T_{LOCK}$	Lock time	-		-	-	200	$\mu\text{s}$

Table 6. Electrical specifications (continued)

Symbol	Parameter	Test conditions	Min	Typ	Max	Unit
<b>ADC</b>						
I <sub>DDA</sub>	Supply current in operating mode	V <sub>AVDD</sub> = 3.3V	-	10	15	mA
I <sub>STDBYA</sub>	AVDD supply current in standby	V <sub>AVDD</sub> = 3.3V	-	2	-	µA
DR	Dynamic range	1 kHz, A-weighted V <sub>AVDD</sub> = 3.3 V	-	90	-	dB
SNR <sub>ADC</sub>	Signal to noise ratio	1 kHz, A-weighted V <sub>AVDD</sub> = 3.3 V	-	92	-	dB
THD <sub>ADC</sub>	Total harmonic distortion	1 kHz, -1dB V <sub>AVDD</sub> = 3.3 V	-	85	-	dB
CT	Channel cross talk	V <sub>AVDD</sub> = 3.3 V	-	80	-	dB
-	Group delay	F <sub>s</sub> mode (f <sub>S</sub> = 32 kHz)	-	0.4	-	ms
		F <sub>s_by_2</sub> mode (f <sub>S</sub> = 16 kHz)	-	0.7	-	
		F <sub>s_by_4</sub> mode (f <sub>S</sub> = 8 kHz)	-	1.4	-	
-	Pass band	-	-	0.4535	-	Fs
-	Pass band ripple	F <sub>s</sub> mode (f <sub>S</sub> = 44.1 kHz)	-	0.08	-	dB
		F <sub>s_by_2</sub> mode (f <sub>S</sub> = 22.05 kHz)	-	0.08	-	
		F <sub>s_by_4</sub> mode (f <sub>S</sub> = 11.025 kHz)	-	0.08	-	
-	Stop band attenuation	F <sub>s</sub> mode (f <sub>S</sub> = 44.1 kHz)	-	45	-	dB
		F <sub>s_by_2</sub> mode (f <sub>S</sub> = 22.05 kHz)	-	45	-	
		F <sub>s_by_4</sub> mode (f <sub>S</sub> = 11.025 kHz)	-	45	-	
-	Frequency response	-3 dB	-	7	-	Hz
		-0.08 dB	-	50	-	Hz
-	Linear phase deviation	at 20 Hz	-	19.35	-	deg
-	Pass-band ripple	-	-	0.08	-	dB
<b>Headphone detector threshold limits</b>						
E_HP1	HP low threshold	-	-	2.34	-	V
	HP high threshold	-	-	2.52	-	
E_HP2	HP low threshold	-	-	0.7	-	V
	HP high threshold	-	-	0.9	-	

Figure 3. Test circuit

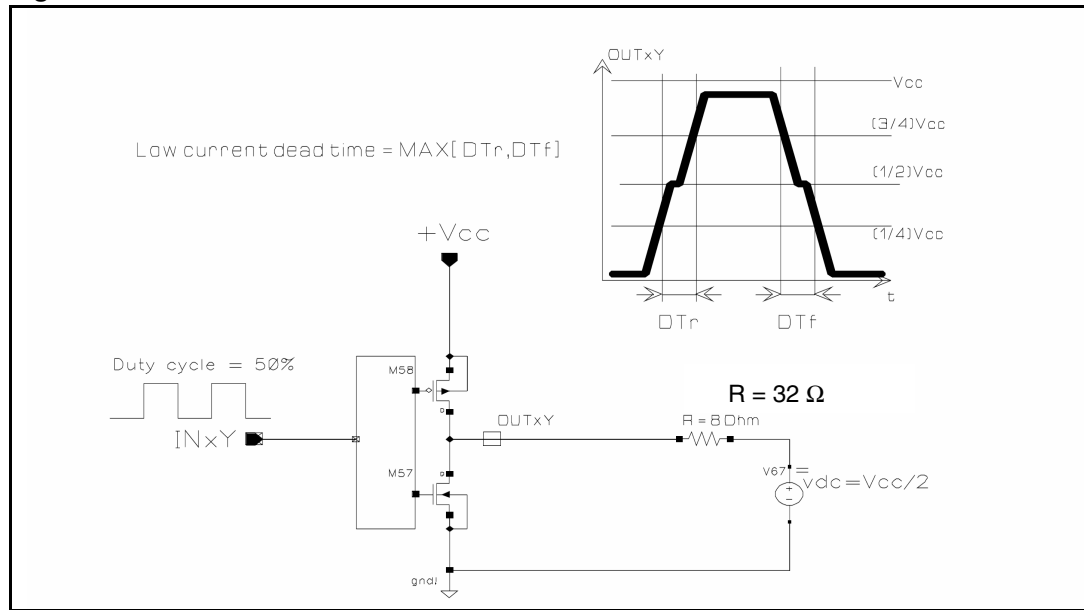

### 3.4 Embedded crystal oscillator

Figure 4. Oscillator configuration

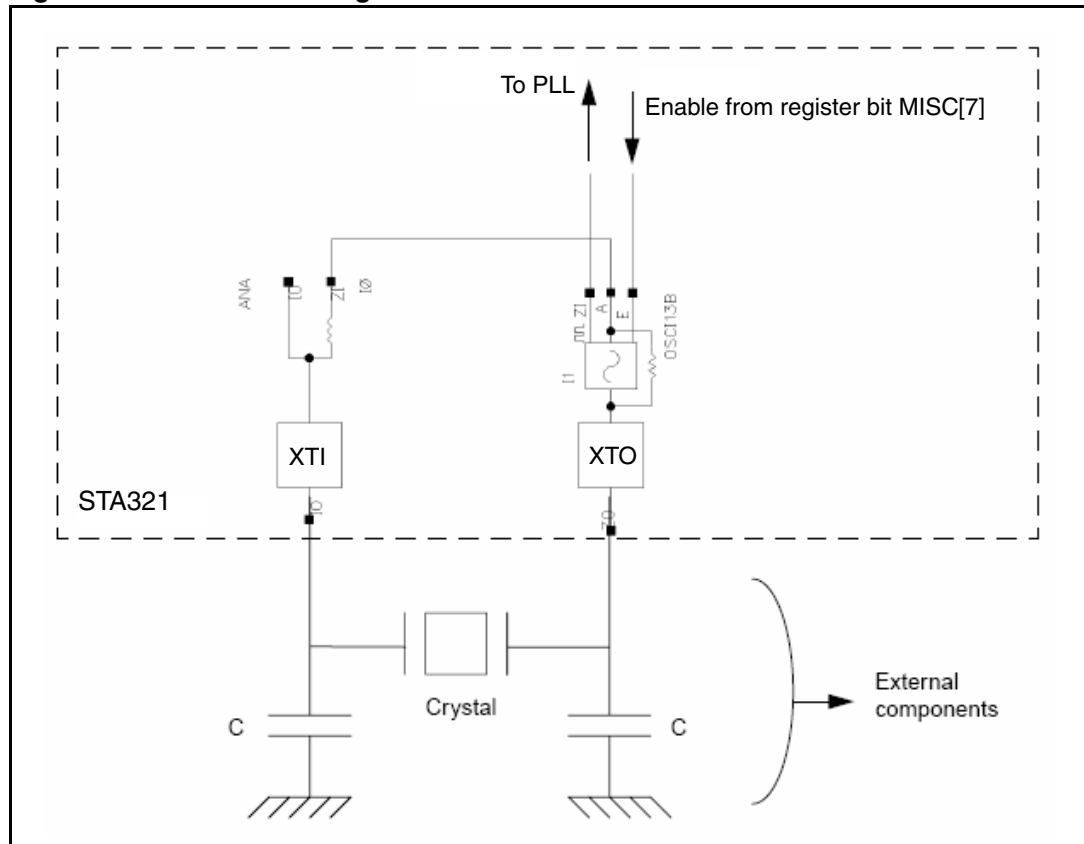

The STA321 has an integrated oscillator between pins XTI and XTO.

The architecture is a single-stage oscillator with an inverter working as an amplifier. The oscillator stage is biased by an internal resistor (of about 500 kΩ), and requires an external PI network consisting of a crystal and two capacitors as shown in *Figure 4* below. An enable feature is provided in bit 7 of register MISC (address 0xC8) to stop the oscillator and thereby to reduce power consumption.

Not all crystals operate satisfactorily with the type of oscillator used in the STA321. To find out if a crystal is suitable for this device the following transconductance formula must be evaluated and compared to the critical transconductance for the embedded oscillator:

$$G_m = R_m * \omega^2 * (C + 2 * C_o)^2 < G_{mCRITICAL} / 3$$

where  $\omega$  is the crystal operating frequency,  $C = C_A = C_B$ ,  $C_o$  and  $R_m$  are shown in *Figure 5* and  $G_{mCRITICAL}$  is given in *Table 7*.

**Figure 5. Equivalent circuit of crystal and external components**

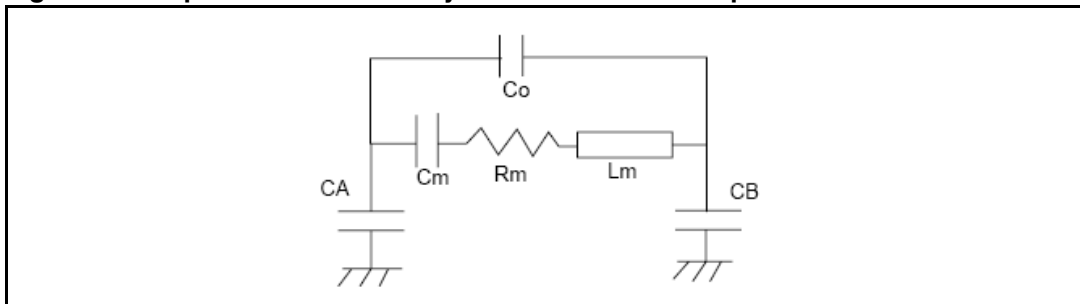

**Table 7. Oscillator specifications**

Symbol	Parameter	Min	Typ	Max	Unit
$I_{OSC}$	Oscillator power consumption with crystal connected <sup>(1)</sup>	-	-	215	μA
Duty <sub>OSC</sub>	Duty cycle	46.9	47.8%	48.9	%
$T_{UP}$	Startup time	-	$15 * \tau_X$	-	s <sup>(2)</sup>
$G_{mCRITICAL}$	Oscillator transconductance	1060	-	-	μA/V

1. If no crystal is connected then the power consumption could be much higher.
2.  $\tau_X$  is the time constant of the crystal and external components; a typical value is 44 μs.

### 3.5 Embedded DC regulator

The power supply to the digital STA321 core and PLL is provided via embedded linear DC regulators as shown below in [Figure 6](#). When pin REG\_BYPASS is tied to ground, the DC regulators are active so that a voltage in the range 2.5 V to 3.6 V applied to pins VDD\_REGx or PVDD provides a regulated internal voltage to the core and the PLL. The voltages Vddi and Vddipll range from 1.55 V to 1.95 V depending on operating conditions.

**Figure 6. Embedded DC regulator scheme**

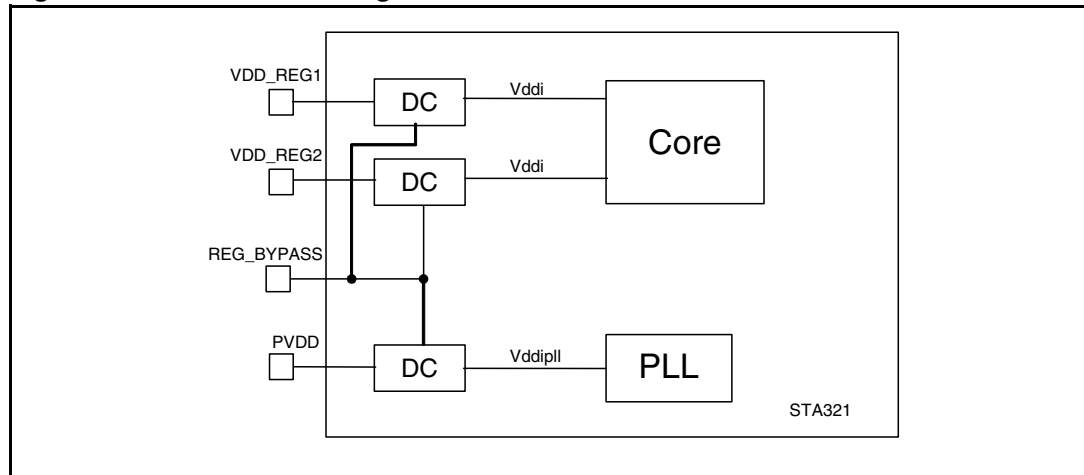

If the application allows multiple supplies or the power supply requirements are a fundamental constraint, pin REG\_BYPASS can be tied high and a 1.8 V external supply can be applied directly to pins VDD\_REGx and PVDD. In this case the operating range for such an external supply is 1.55 V to 1.95 V.

Embedded DC regulators imply also static power consumption that must be taken into account when the power-down modes are active. The STA321 provides a deep powerdown mode where also the regulators are active but in a low power consumption mode (see [Section 4.3.2 on page 27](#)).

## 4 Power-up and power-down sequences

### 4.1 Device power-up

After providing the power supply to the device, it is necessary to wait until the DC regulator PWUP time has elapsed before the device can be set up and used for normal operations. (see [Figure 7](#)).

**Figure 7. Startup sequence**

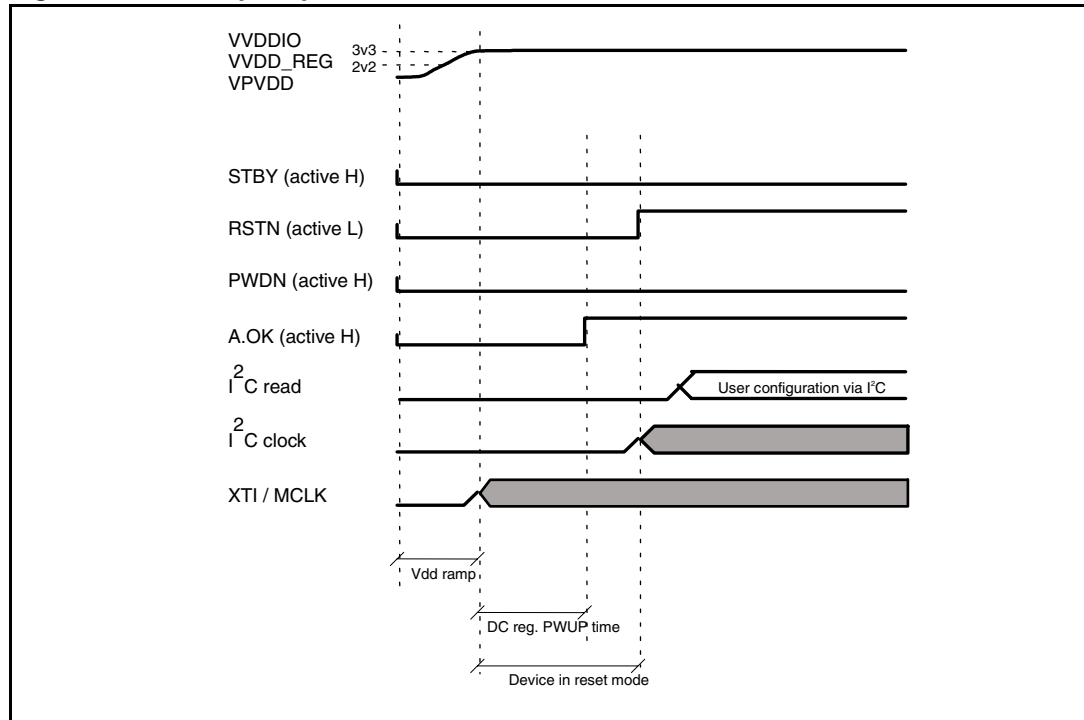

**Table 8. Power-up signal description**

Signal/pin	Type	Description
VDDIO	Supply	Power supply of the digital pads (= VDDIO1,2)
VDD_REG	Supply	Power supply of the system core (= VDD_REG1,2)
PVDD	Supply	Power supply of the PLL
STBY	In (digital)	External standby signal provided by the user
RSTN	In (digital)	External reset signal provided by the user
PWDN	Internal	Power-down of the DC regulator cell, controlled by the core
A. OK	Internal	DC regulator status, when active the 1.8 V is provided to the core
I <sup>2</sup> C read	In (I <sup>2</sup> C)	Configuration commands coming to the I <sup>2</sup> C interface
I <sup>2</sup> C clock	Internal	I <sup>2</sup> C peripheral clock
XTI/MCLK	In (digital)	Clock input source

**Table 9. Startup timings**

Parameter	Description	Min	Typ	Max	Unit
DC reg. power-up time	Start up time of the DC Regulator after connecting the power	-	-	300	µs
Device in reset mode	Must be greater than (VDD time + DC reg. power-up time)	-	-	-	µs

**Table 10. Configuration example**

Register address	Value	Description
0xC9	0x00	Remove PLL bypass
0xCA	0x00	Headphone detection polarity = 0
0xB8	0x4A	Configure SAI output: SAI_out1 = SAI_in1, SAI_out2 = SAI_in2
0xB7	0x38	SRC source select: SRC1 = ADC, SRC2 = ADC
0xC6	0x02	ADC clock on
0xB2	0xF3	I <sup>2</sup> S configuration
0xC8	0x21	Core clock on, SAI/ADC audio set to 32 kHz - 48 kHz range
0xB2	0xD3	SAI_out: output enabled
0xA0	0x00	Soft volume removed
0x00	0x00	Remove bridge 3-state

## 4.2 Software power-down mode

The software power-down is obtained by configuring the appropriate I<sup>2</sup>C registers.

In order to obtain flexibility every peripheral has its independent, standby signal and several gating clock cells are available.

Obviously, the I<sup>2</sup>C peripheral can not be turned off in this mode, otherwise the device can recover from the power-down state only via the reset pin.

In the table below EA is embedded amplifier and CB is CMOS bridge. For complete information this table must be used in conjunction with [Chapter 14: Register description on page 77](#).

**Table 11. Registers for power-down**

Description	Register bit	Address
Put EA in standby	<a href="#">FFXCFG1</a> [7]	<a href="#">0x00 on page 81</a>
Put CB in standby	<a href="#">FFXCFG1</a> [6]	<a href="#">0x00</a>
Put PLL in standby	<a href="#">PLLPE</a> [5]	<a href="#">0xC4 on page 132</a>
Put ADC in standby	<a href="#">ADCCFG0</a> [3]	<a href="#">0xC6 on page 133</a>
Turn core clock off	<a href="#">MISC</a> [0]	<a href="#">0xC8 on page 135</a>
Turn ADC clock off	<a href="#">ADCCFG0</a> [1]	<a href="#">0xC6</a>

**Table 11. Registers for power-down (continued)**

Description	Register bit	Address
Turn SRC clock off	CKOCFG[3]	0xC7 on page 134
Turn PROC clock off	CKOCFG[2]	0xC7
Turn FFX clock off	CKOCFG[4]	0xC7

### 4.2.1 Configuration example

This is an example of the register setup for power-down clock. It is assumed that every peripheral is already configured and working correctly.

There are other configuration examples to help you get started please refer to other chapters and also to [Chapter 14: Register description on page 77](#) in order to get all the necessary and complementary details.

Turn off all the peripherals.

*Note:* The MCLK (or XTI) must be used as system clock (sys\_clk) before setting the PLL to standby.

**Table 12. Example configurations for power-down**

Register bit	Address	Value	Description
EA_STBY CB_STBY	0x00 on page 81	0xC0	Set the embedded power amplifier and CMOS bridge to power-down
CLK_FFX_ON	0xC7 on page 134	0x0C	Turn off the FFX modulator clock
ADC_STBY	0xC6 on page 133	0x09	Set the ADC into standby mode
CLK_ADC_ON	0xC6	0x80	Turn the ADC clock off
CLK_PROC_ON	0xC7	0x08	Turn the processing clock off
CLK_SRC_ON	0xC7	0x00	Turn the sample rate converter clock to off
PLL_BYP_UNL	0xC4 on page 132	0x80	Bypass the PLL clock and use MCLK (or XTI) as source clock when the PLL is not locked (a safety operational mode)
PLL_PWDN	0xC4	0xA0	Put the PLL in standby
CLK_CORE_ON	0xC8 on page 135	0x00	Turning off the core clock

### 4.3 Hardware power-down mode

The hardware power-down is obtained by asserting pin STBY to high.

There are two power-down options available, namely mild mode and full (or deep) mode, that could be selected using the DC\_STBY\_EN signal in register STBY\_MODES

Figure 8 summarizes the main power-down sequence. "Power on" is the normal operating status where all the startup procedures have already been executed. The rectangular boxes indicate the steps to be done by the user whilst the rounded boxes indicate the steps done by the device.

Figure 8. Hardware power-down sequence

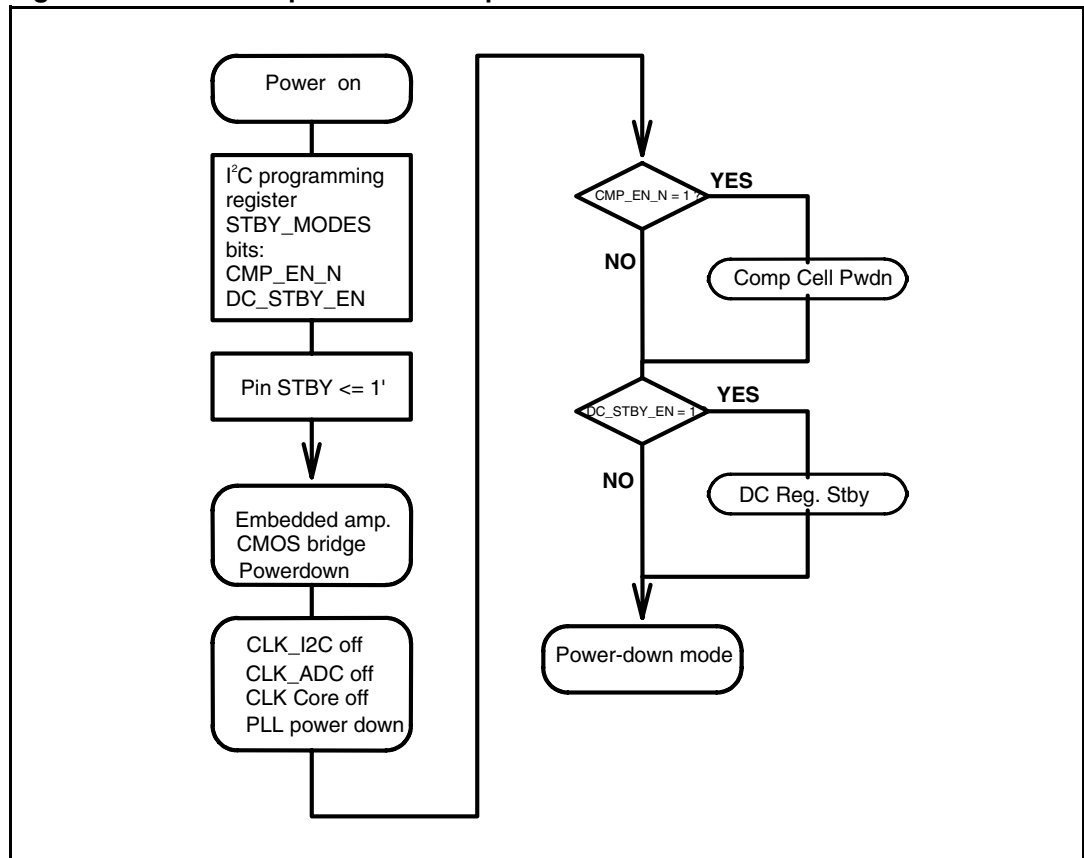

Table 13. Frequently used signals

Name	Description
STBY	Input pin <a href="#">STBY on page 11</a>
PWDN DC regulator	Internal
A. OK DC regulator	Internal
CMP_EN_N	Bit 1, register <a href="#">STBY_MODES on page 139</a>
EA_STBY CB_STBY	Bits 7:6, register <a href="#">FFXCFG1 on page 81</a>
EA/CB volume	Internal
PLL_UNLOCK	Bit 7, register <a href="#">PLLST on page 132</a>
PLL_PWDN	Bit 5, register <a href="#">PLLPE on page 132</a>
CLK_PROC_ON	Bit 2, register <a href="#">CKOCFG on page 134</a>
CLK_PROC	Processing clock
CLK_FFX_ON	Bit 4, register <a href="#">CKOCFG on page 134</a>
clk_ffx	FFX clock
CLK_ADC_ON	Bit 1, register <a href="#">ADCCFG0 on page 133</a>
clk_adc	ADC clock
CLK_SRC_ON	Bit 3, register <a href="#">CKOCFG on page 134</a>
clk_src	SRC clock
CMP_EN_N	Bit 1, register <a href="#">STBY_MODES on page 139</a>
DC_STBY_EN	Bit 0, register <a href="#">STBY_MODES on page 139</a>
FFX_ULCK_PLL	Bits 4:3, register <a href="#">FFXCFG1 on page 81</a>

### 4.3.1 Mild power-down

In this case, the device is put into a mild power-down mode.

All the peripherals are set to standby and their clocks turned off.

The I<sup>2</sup>C configuration is not required as the default values of the registers are sufficient.

- Initial conditions:
  - FFX\_ULCK\_PLL = 10
  - CMP\_EN\_N = 0
  - DC\_STBY\_EN = 0
- Going into power-down:

After the assertion of the pin STBY, the following actions are taken by the device:

  1. Embedded amplifier (EA) and CMOS bridge (CB) volume are set to mute (the length of this step changes according to the fade-out ramp configuration).
  2. EA and CB are put into power-down.

After the previous operation is completed:
  3. All peripherals are turned off (regardless the register settings).
  4. The PLL clock is bypassed, the system clock (sys\_clk in [Figure 11 on page 29](#)) is XTI.
  5. All clocks are shut down.
- Returning to normal mode:

After the release of the pin STBY, the power-up procedure takes place:

  1. All clocks are turned on.
  2. All peripherals are restored to their previous status (based on the last register settings).
  3. If the PLL clock was the system clock it will be selected again after the locking time.
  4. The EA and the CB execute the fade-in procedure before becoming ready to be used (the length of this step changes according to the fade-in ramp configuration).

Figure 9. Hardware powerdown sequence (mild mode)

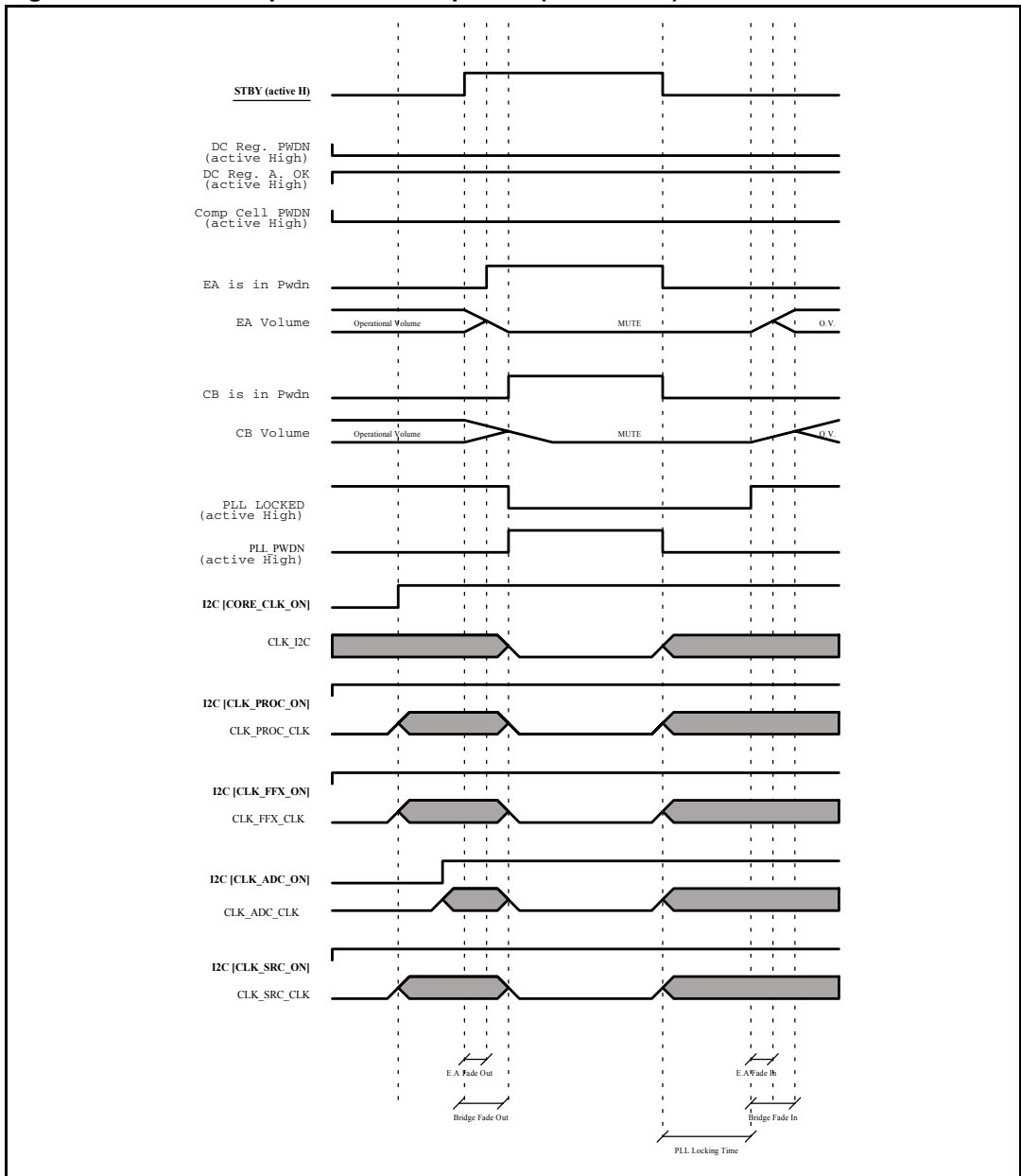

### 4.3.2 Full power-down

In this case the device is put into a full power-down mode.

This implies lower power consumption than the mild mode, but has a drawback in that it takes longer to execute.

- Initial conditions
  - FFX\_ULCK\_PLL = 10
  - CMP\_EN\_N = 1
  - DC\_STBY\_EN = 1
- Going into power-down:

This mode differs from the previous one by an additional step at the end of the power-down procedure and at the beginning of the power-up:

  1. Embedded amplifier (EA) and CMOS bridge (CB) volume are set to mute (the length of this step changes according to the fade-out ramp configuration).
  2. EA and CB are put into power-down.

After the acknowledge signals (EA is in power-down and CB is in power-down) are received:
  3. All peripherals are turned off (regardless the register settings).
  4. PLL clock is bypassed, the system clock (sys\_clk in [Figure 11 on page 29](#)) is XTI.
  5. All clocks are shut down.
  6. DC regulator is put into standby mode. After this point the device is in a very low power consumption mode.
- Returning to normal mode:

After the release of pin STBY, the power-up procedure will take place:

  1. DC regulator is set to operational mode

After the acknowledge signal (DCAOK) from the DC regulator is received:
  2. All clocks are turned on.
  3. All peripherals are restored to the status based on their relative register settings.
  4. If the PLL clock was the system clock it is selected again after the locking time.
  5. The EA and the CB execute the fade-in procedure before being ready to be used (the length of this step changes according to the fade-in ramp configuration).

Figure 10. Hardware power-down sequence (full mode)

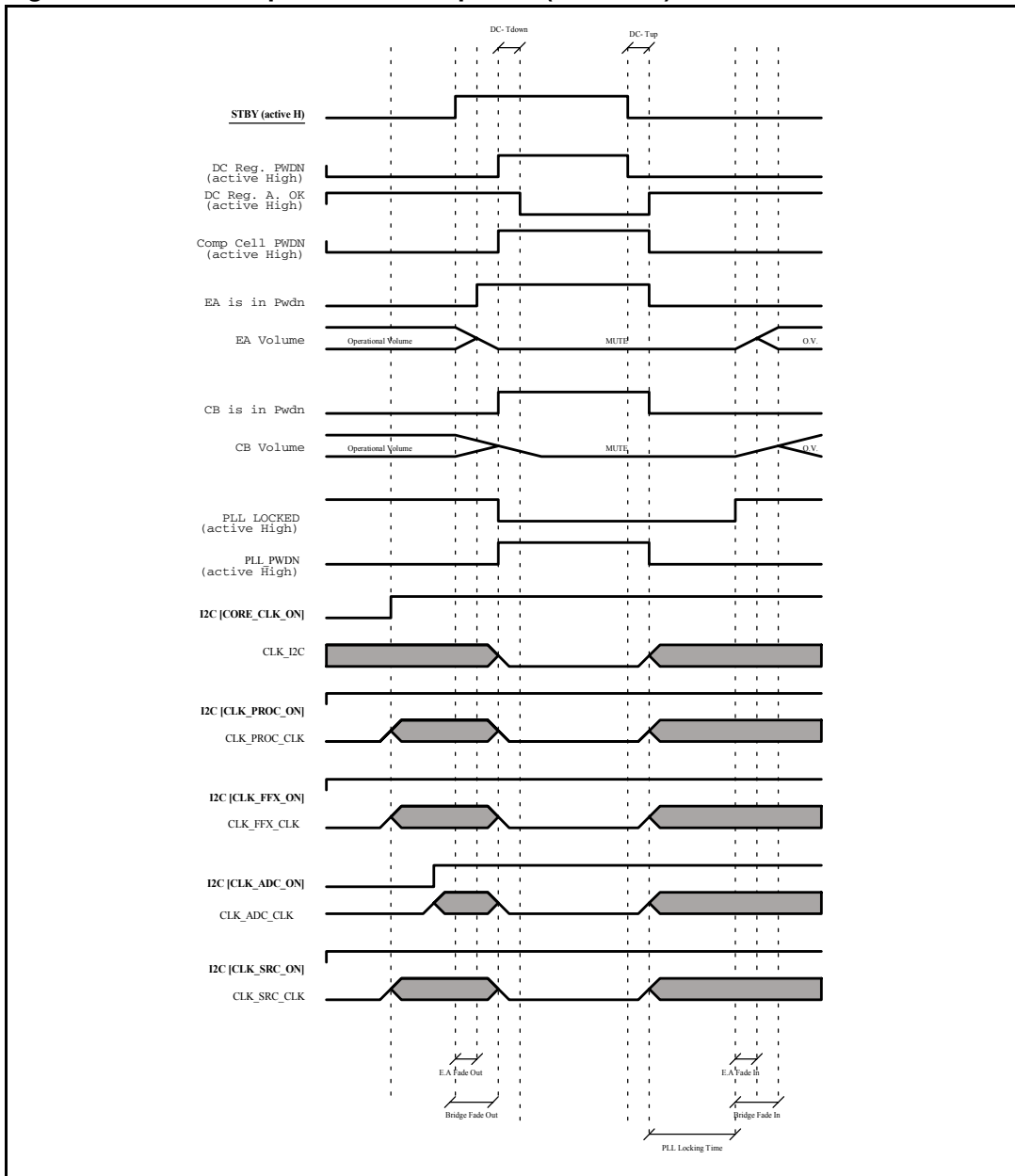

# 5 Clock management

Figure 11. Clock management scheme

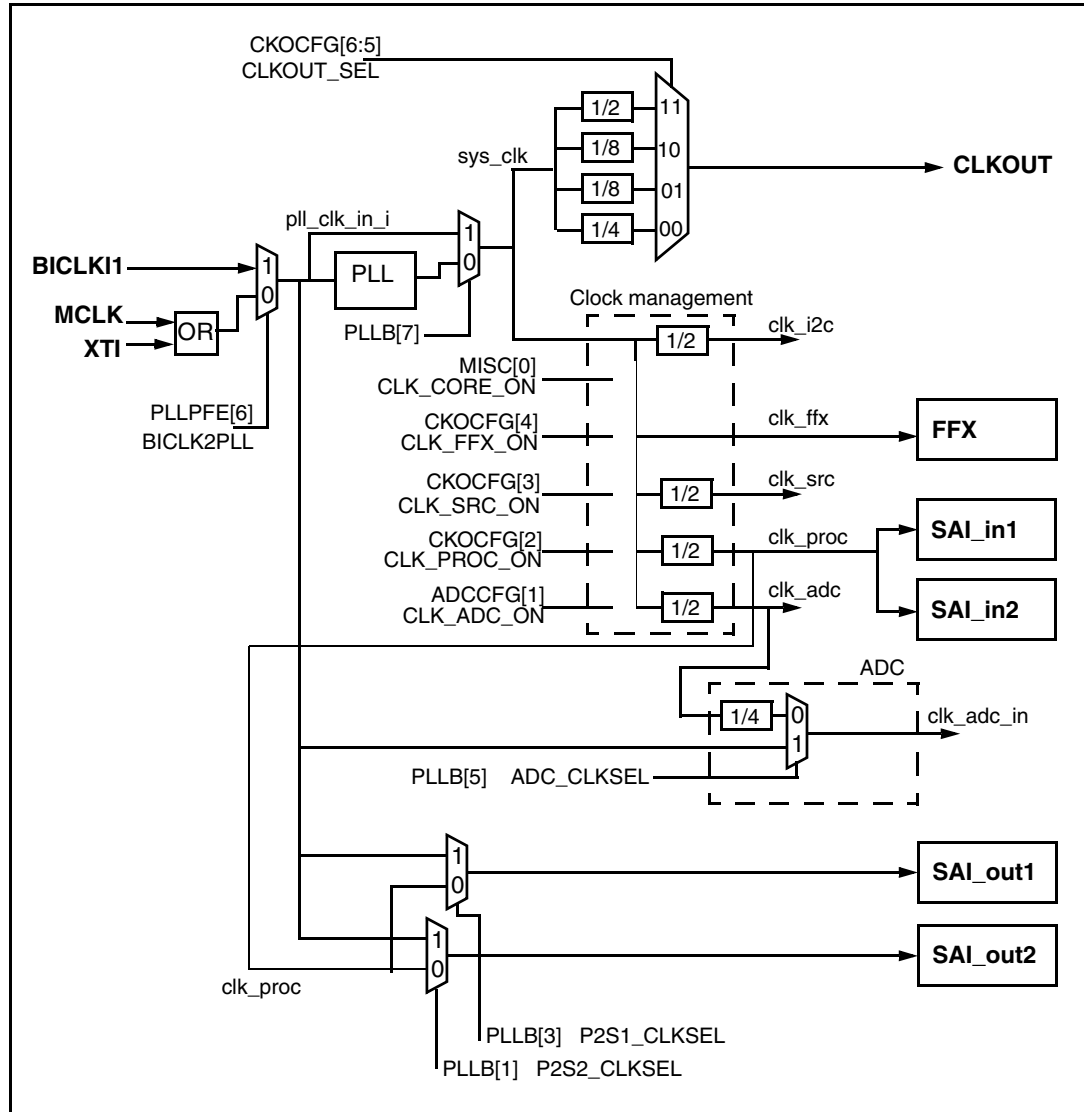

Table 14. Clock control registers

Register Name	Address
<a href="#">PLL on page 136</a>	0xC9
<a href="#">ADCCFG0 on page 133</a>	0xC6
<a href="#">CKOCFG on page 134</a>	0xC7

**Table 15. Clock characteristics**

Symbol	Parameter	Min	Typ	Max	Unit
f <sub>MCLK_Range</sub>	Input clock frequency range	2.048	-	49.152	MHz
Duty <sub>MCLK</sub>	Input clock duty cycle	40	-	60	%
t <sub>MCLK_RF</sub>	Input clock rise/fall time	-	-	0.2	ns
f <sub>XTI_Range</sub>	Input clock frequency range	2.048	-	49.152	MHz
Duty <sub>XTI</sub>	Input clock duty cycle	40	-	60	%
t <sub>XTI_RF</sub>	Input clock rise/fall time	-	-	0.2	ns
f <sub>BICK1_Range</sub>	Input clock frequency range	2.048	-	49.152	MHz
Duty <sub>BICK1</sub>	Input clock duty cycle	40	-	60	%
t <sub>BICK1_RF</sub>	Input clock rise/fall time	-	-	0.2	ns
f <sub>CLKOUT_Range</sub>	Output clock frequency range	-	-	49.152	MHz

## 5.1 System clock

Figure 11 above shows the STA321 clock management scheme with all the major clocks. As can be seen, the system clock (sys\_clk) is selected from one of three sources by using register [PLL B on page 136](#):

- an external clock BICK1
- (default) an external clock XTI or MCLK (the unused one must, however, be set to 0)
- the internal PLL.

If the PLL is used there are some design constraints:

- pll\_clk\_in\_i must be in the range: 2.048 MHz to 49.152 MHz
- pll\_clk\_out must be in the range: 65.536 MHz to 98.304 MHz.

The sys\_clk is routed to the peripherals through the clock manager section.

### 5.1.1 Configuration example

This is an example of the PLL register setup. It is assumed that every peripheral is already configured and working correctly.

There are other configuration examples to help you get started please refer to other chapters and also to [Chapter 14: Register description on page 77](#) in order to get all the necessary and complementary details.

Starting with MCLK as system clock switching to PLL as source

**Table 16. Register setup to provide sys\_clk from MCLK to PLL**

Register	Address	Value	Description
PLLPFE	0xC4	0x80	Safety operational mode: automatic use of MCLK (or XTI) as system clock if the PLL is not locked
PLL B	0xC9	0x00	Remove the PLL bypass and use its clock as system

## 5.2 Peripheral clock manager

This block manages the clocks of the core processing peripherals ADC, FFX, PROC (including memories and SAI interfaces) and SRC.

A clock divider (by 2) is attached before every block except the FFX.

Each block is attached to a global gating cell and to a dedicated one. This allows a flexible power-consumption management because it is possible to turn off either the whole processing chain or just a single block. The only exception is the I<sup>2</sup>C peripheral clock which is disabled only when the device is in hardware power-down mode. In all the other cases this clock remains active.

## 5.3 Fractional PLL

The PLL specifications are given in [Table 6 on page 14](#).

Figure 12. PLL block diagram

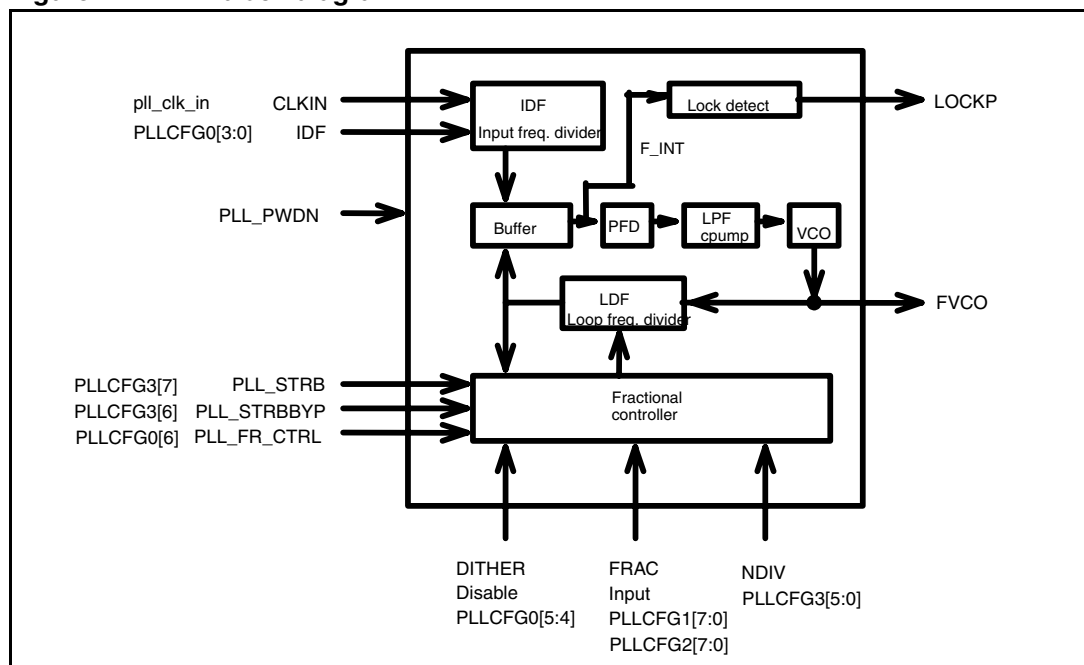

### 5.3.1 PLL block description

#### Phase/frequency detector (PFD)

This block compares the phase difference between the corresponding rising edges of the `F_INT` and the clock coming from the loop frequency divider.

It generates voltage pulses with widths proportional to the input phase error.

#### Charge pump and loop filter (LPF/CPUMP)

This block converts the voltage pulses from the phase/frequency detector to current pulses which charge the loop filter and generate the control voltage for the voltage controlled oscillator (VCO).

**Voltage controlled oscillator (VCO)**

This is the oscillator inside the PLL, which produces a frequency,  $f_{VCO}$ , on output FVCO proportional to the input control voltage.

**Input frequency divider (IDF)**

This frequency divider divides the PLL input clock CLKIN by the input division factor (IDF) to generate the PFD input frequency. IDF is programmed in register PLLCFG0[3:0].

**Loop frequency divider (LDF)**

This frequency divider is present within the PLL for dividing the VCO output by the loop division factor (LDF). LDF is programmed in register bits PLLCFG3[5:0].

**Lock circuit**

The output of this block, signal LOCKP, is asserted high when the PLL enters the state of coarse lock in which the output frequency is  $\pm 10\%$  of the desired frequency. LOCKP is refreshed every 32 cycles of F\_INT. The status bit PLL\_UNLOCK is in register [PLLST](#) on [page 132](#).

**5.3.2 Output frequency computation**

The input clock frequency of the phase/frequency detector (PFD) is

$$f_{F\_INT} = CLKIN / IDF$$

The VCO frequency depends on the value of register bit PLLCFG0.PLL\_FR\_CTRL such that

When PLL\_FR\_CTRL = 1

$$f_{VCO} = f_{F\_INT} * (LDF + FRAC / 2^{16} + 1 / 2^{17})$$

and when PLL\_FR\_CTRL = 0

$$f_{VCO} = f_{F\_INT} * LDF$$

Notes:

1. When dither is disabled (PLL\_DDIS = 1), the factor  $1 / 2^{17}$  is not used in the multiplication.
2. There are some limits to the input and output frequencies as given in [Table 17](#) and [Table 18](#) when selecting the values for IDF, LDF, and FRAC.
3. The LDF values of 5, 6 and 7 cannot be used when fractional synthesis mode is on, that is, when PLL\_FR\_CTRL = 1.
4. The fractional control bits (FRAC\_INPUT) must be set to the required values before activating the fractional synthesis mode.

**Table 17. Input division factor (IDF)**

IDF[3]	IDF[2]	IDF[1]	IDF[0]	Input division factor (IDF)
0	0	0	0	1
0	0	0	1	1
0	0	1	0	2
...	...	...	...	...

Table 17. Input division factor (IDF) (continued)

IDF[3]	IDF[2]	IDF[1]	IDF[0]	Input division factor (IDF)
1	1	1	0	14
1	1	1	1	15

Table 18. Loop division factor (LDF)

NDIV[5]	NDIV[4]	NDIV[3]	NDIV[2]	NDIV[1]	NDIV[0]	Loop division factor (LDF)
0	0	0	0	x	x	NA
0	0	0	1	0	0	NA
0	0	0	1	0	1	5 <sup>(1)</sup>
0	0	0	1	1	0	6 (see note 3)
0	0	0	1	1	1	7 (see note 3)
0	0	1	0	0	0	8
...	...	...	...	...	...	...
1	1	0	1	1	0	54
1	1	0	1	1	1	55
1	1	1	x	x	x	NA

1. The LDF values of 5, 6 and 7 cannot be used when fractional synthesis mode is ON (PLL\_FR\_CTRL = 1)

## 6 Digital processing stage

### 6.1 Signal processing flow

The STA321 provides 4 channels of audio signal processing. The block diagram is shown in the following figure.

**Figure 13. Processing flow**

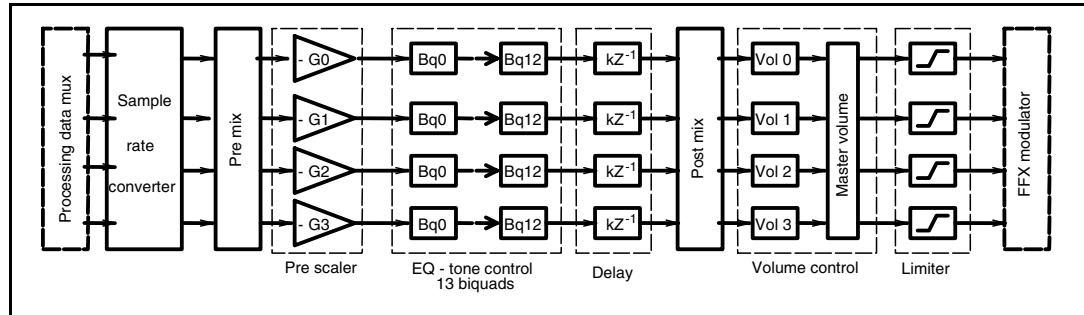

Left and right channels coming from the two serial audio interfaces and ADC (left and right channels) are fed into the selection multiplexer (controlled by register [SRCINSEL on page 128](#)), so that each channel can be connected to any desired processing chain. The four channels are then sample rate converted to the fixed internal sampling rate. Pre mix, EQ/tone processing, programmable delay, post mix, and volume/limiter make up the STA321 signal processing chain.

**Figure 14. Processing data multiplexer**

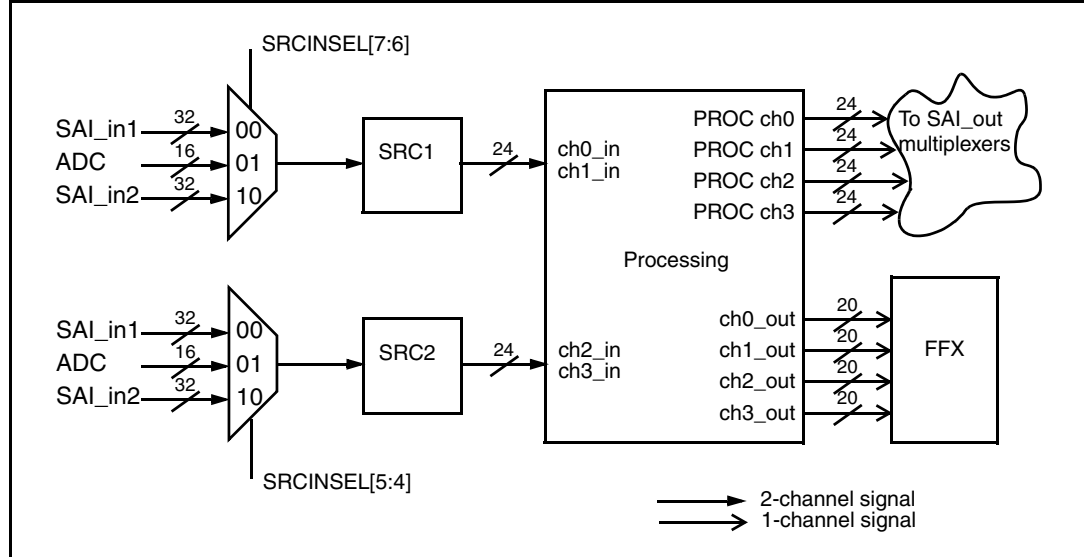
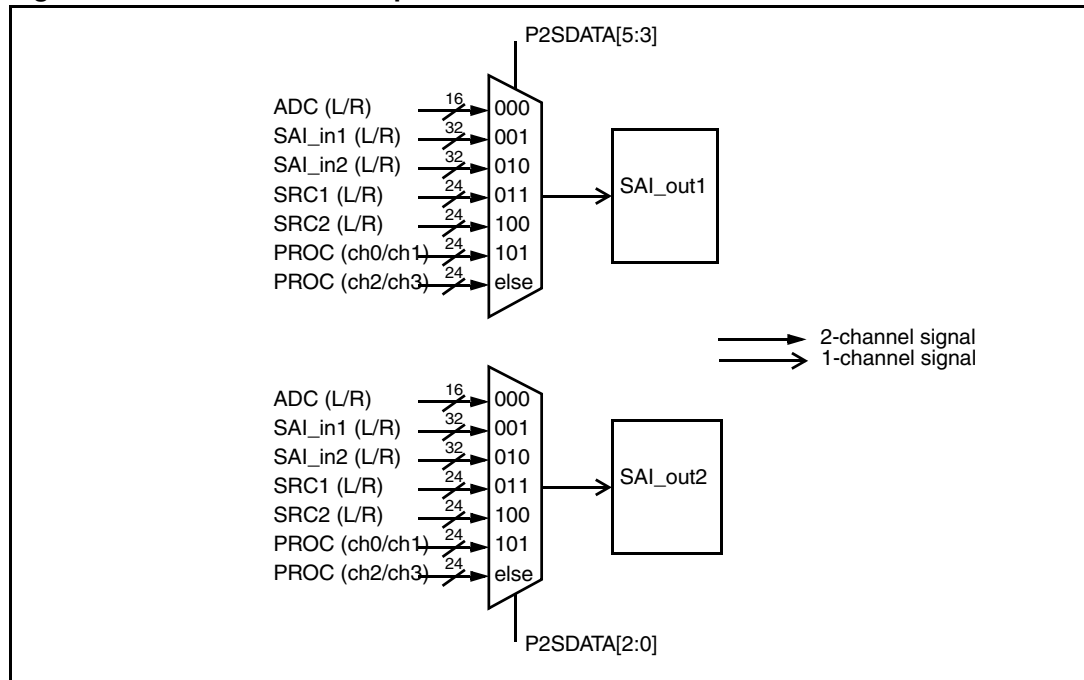

Figure 15. SAI\_out data multiplexer



## 6.2 Sampling rate converter

The sample rate converter (SRC) re samples the input data source in order to send to the processing block an audio stream always with a fixed frequency:

sampling frequency,  $f_S = f_{\text{sys\_clk}} / 1024$  where  $f_{\text{sys\_clk}}$  is the system clock frequency.

In all the examples given here,  $f_S = 96 \text{ kHz}$ .

Figure 16. Sample rate converter block diagram

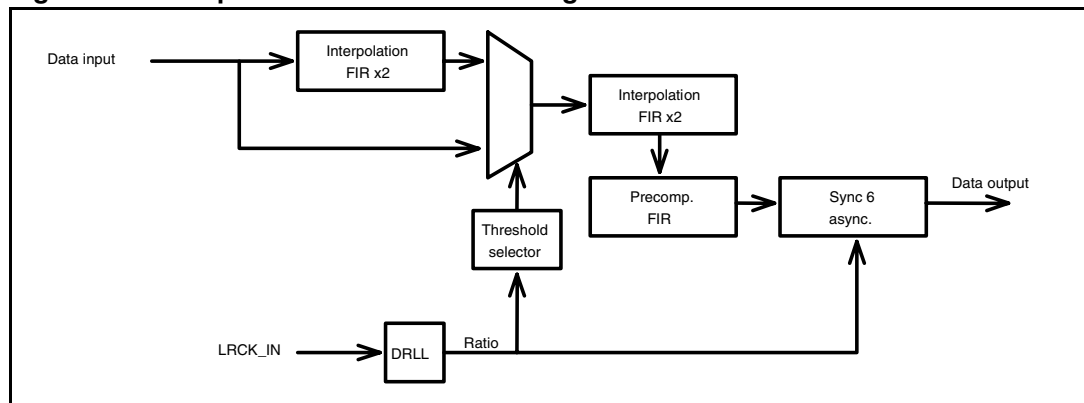

The selection between x2 FIR interpolation and direct input data is made automatically by the threshold selector block. If the input sampling frequency (measured by the DRLL) is higher than the SRC threshold (that is, more than 81 kHz) the direct connection is selected (first filter bypassed), otherwise the first x2 filter is added to the data path.

A 3-kHz hysteresis is fixed around the SRC threshold nominal value in order to prevent unstable oscillations.

### 6.3 Pre-EQ mix 1 and post-EQ mix

The four-channel data, received from the sample rate converters, is sent to Mix1 block to produce the four mixed-channel data for processing. All this data can be mapped to any internal processing channel through the appropriate configuration of the RAM memory locations.

**Table 19. Channel mapping**

Function	Channel	Memory location (RAM)
Pre mixer	Ch0	from 0x00
	Ch1	from 0x04
	Ch2	from 0x08
	Ch3	from 0x0c
Post mixer	Ch0	from 0x118
	Ch1	from 0x11c
	Ch2	from 0x120
	Ch3	from 0x124

The post-EQ mixer acts in a similar way for the output channels from the processing and directed to the FFX. It is placed after the delay block which provides a full 4-channel input mix on every channel.

**Figure 17. Mixers block diagram**

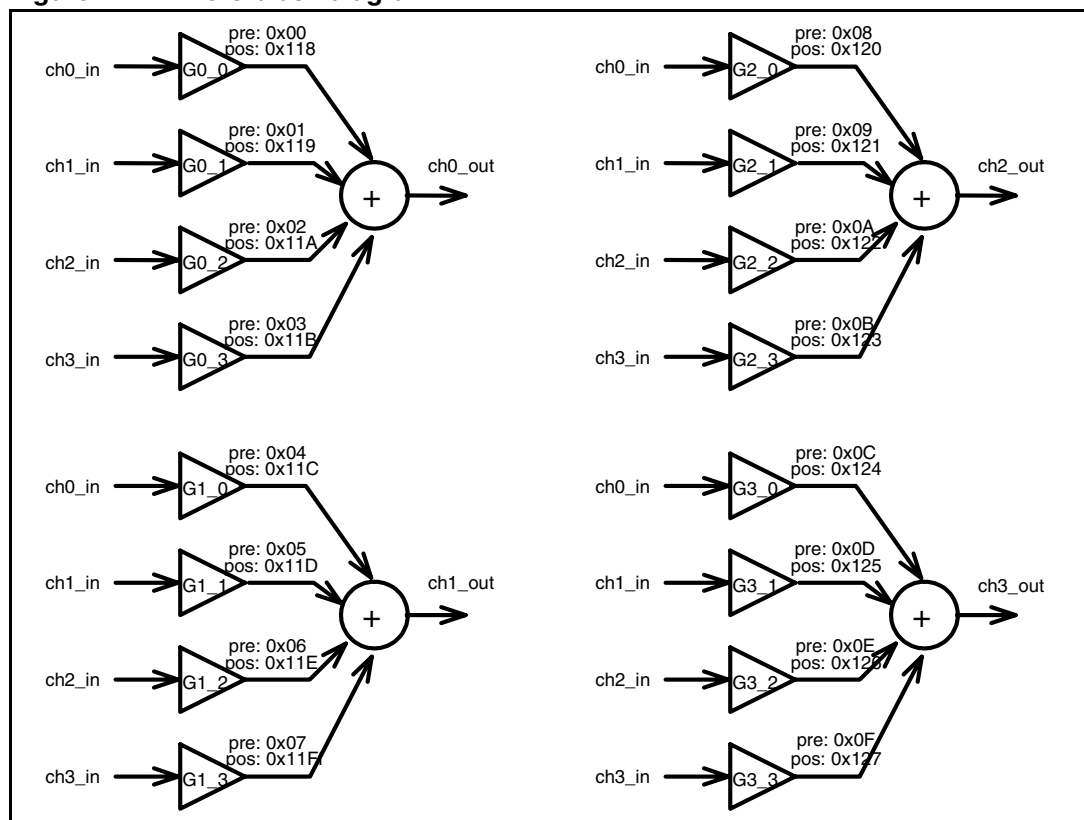

### 6.3.1 Presets

By default, each mixer output is connected to its corresponding input without any attenuation and without any mixing with the other channels:

$$ch0\_out = ch0\_in, ch1\_out = ch1\_in, ch2\_out = ch2\_in, ch3\_out = ch3\_in.$$

## 6.4 Pre scaler

The pre scale block, which precedes the first biquad, could be used to attenuate the input signal when the filters of the processing chain have a gain that could reach the clamping value.

Each channel has a dedicated 24-bit signed multiplier in the range -1 (0x800000) to almost +1 (0x7FFFFFFF).

### 6.4.1 Presets

By default, all pre-scale factors are set to 0x7FFFFFFF

## 6.5 Equalization, tone control and effects

Figure 18. EQ/tone block diagram

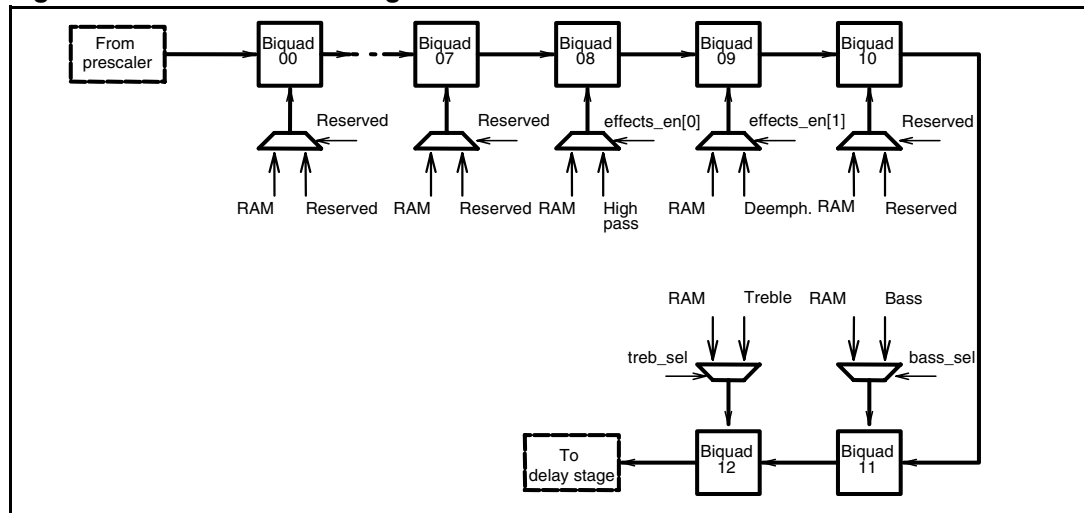

Four channels of input data are fed to the EQ processing block which provides 13 user-programmable biquad filters per channel as shown in [Figure 18](#) above.

A description of the biquad programming is given in [Section 6.14 on page 44](#).

Some filter coefficients are pre-programmed and stored in the non-volatile memory in order to supply particular EQ effects (see [Figure 19](#) and [Table 20 on page 38](#)).

The selection of RAM, ROM bass/treble or ROM effects is made using registers [EFFECTS\\_EN\\_CHn on page 109](#) for the effects and [BASS\\_SELn\\_R on page 111](#) and [TREB\\_SELn\\_R on page 113](#) for the bass/treble. Each biquad can be configured independently.

Figure 19. Biquad coefficient selection

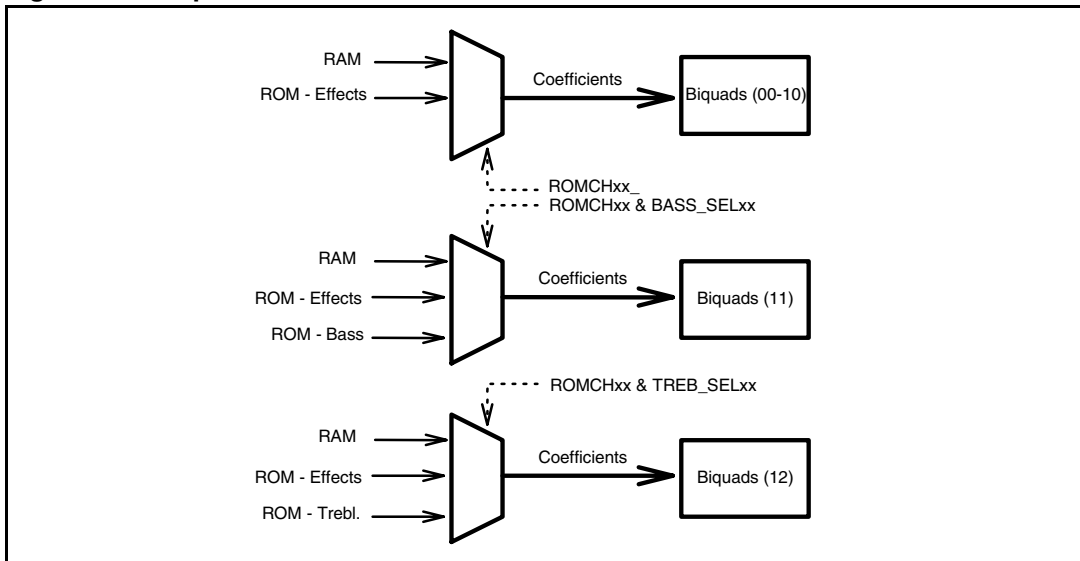

Table 20. EQ control signals

Signal name	Description	Channel	Register addr
effects_en[1]	1: enable deemphasysa filter	Ch0	0x71
		Ch1	0x73
		Ch2	0x73
		Ch3	0x77
bass_sel[5]	1: enable bass tone control	Ch0	0x78
		Ch1	0X79
		Ch2	0X7A
		Ch3	0X7B
treb_sel[5]	1: enable treble tone control	Ch0	0X7C
		Ch1	0X7D
		Ch2	0X7E
		Ch3	0X7F

## 6.6 Biquads

The biquads are based on the following equation and is shown diagrammatically in *Figure 20*.

$$Y[n] = b_0 * X[n] + b_1 * X[n-1] + b_2 * X[n-2] - a_1 * Y[n-1] - a_2 * Y[n-2]$$

where  $Y[n]$  represents the output and  $X[n]$  represents the input. Fractional multipliers are 24-bit signed with coefficient values in the range -1 (0xFFFFF) to +1 (0x7FFFF).

**Figure 20. Biquad filter**

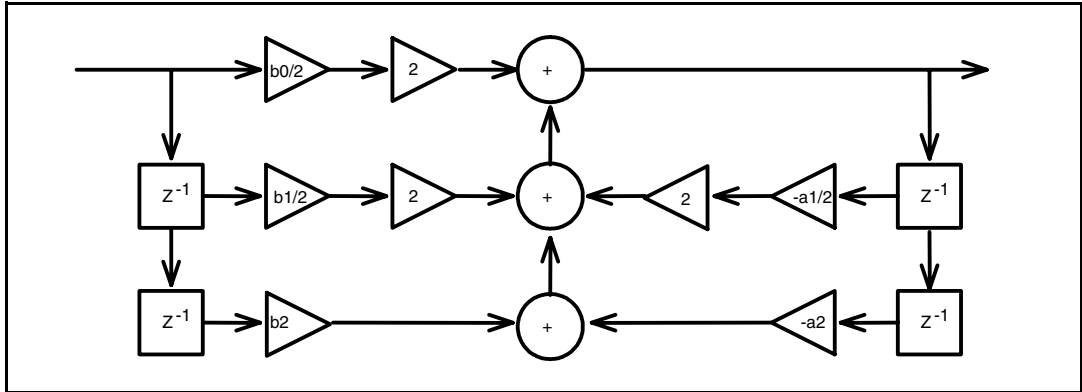

### 6.6.1 Presets

By default all the biquads values in RAM are set to give a bypass function; in actual fact, the signal passes through unchanged. The coefficients for this are:

$$a_1 / 2 = 0, a_2 / 2 = 0, b_0 / 2 = 0.5 (0x400000), b_1 / 2 = 0, b_2 / 2 = 0.$$

## 6.7 High-pass filter

The standard high-pass filter is provided by the STA321

**Figure 21. High-pass filter frequency response**

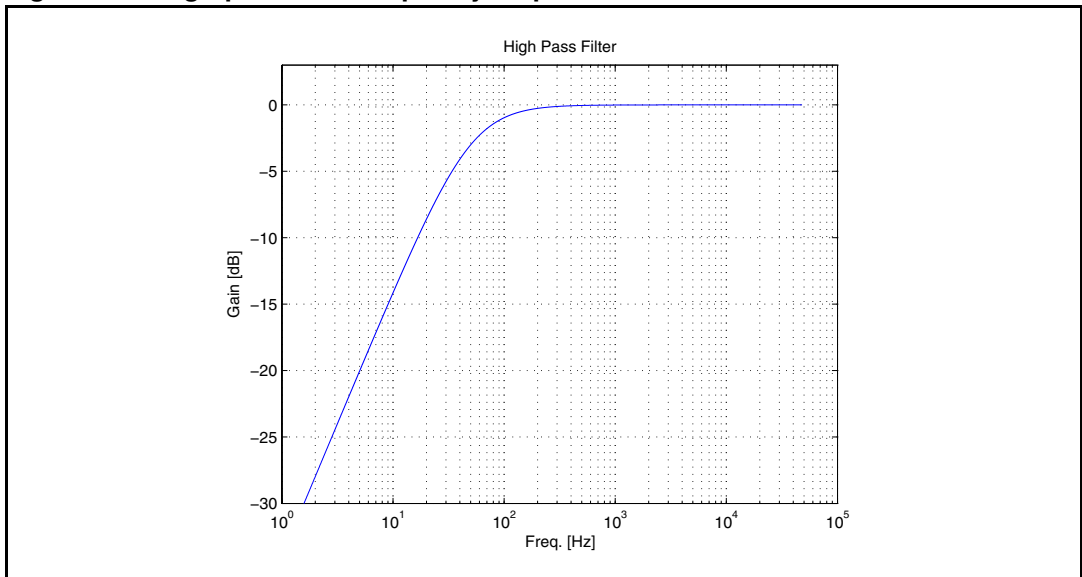

## 6.8 Deemphasis filter

The standard deemphasis filter is provided by the STA321.

**Figure 22. Deemphasis filter frequency response**

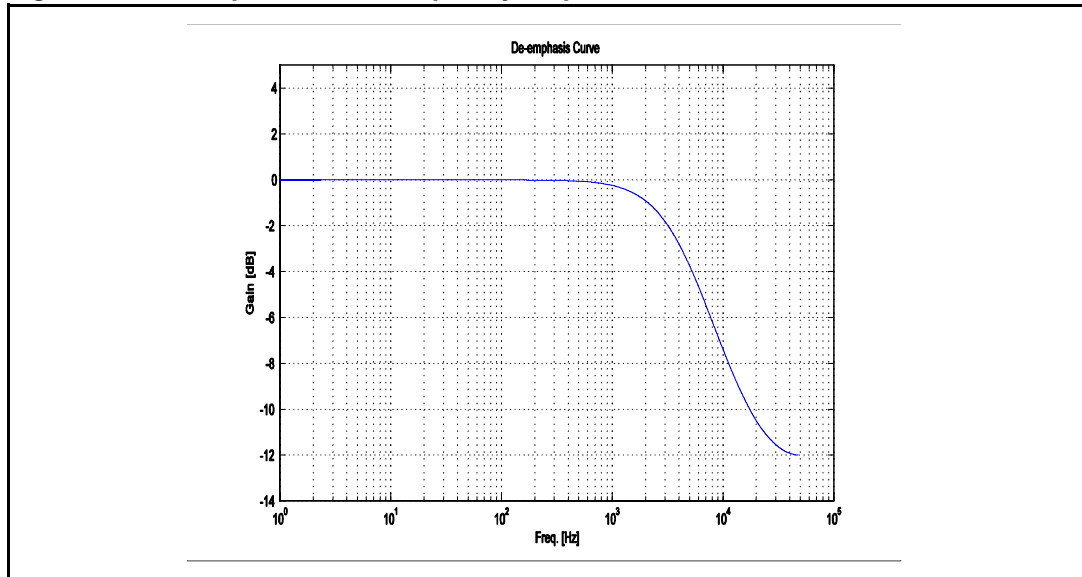

## 6.9 Bass and treble control

Preset values for the 11th and 12th biquads of every channel are stored in ROM in order to achieve a bass and treble tone control.

They are channel independent and have 24 curves ranging from -12 to +12 dB gain with 1 dB steps. Their selection (and enable) is via registers BASS\_SELx\_R and TREB\_SELx\_R where x is the number of the channel to be equalized.

The EQ curve and filter cut-off frequencies are shown in [Figure 23](#) and [Figure 24](#).

With a sampling frequency of 96 kHz (inside the processing block), the cut-off frequencies are 3 kHz for treble curves and 150 Hz for bass curves.

**Figure 23. Frequency responses of treble control at 1-dB gain steps**

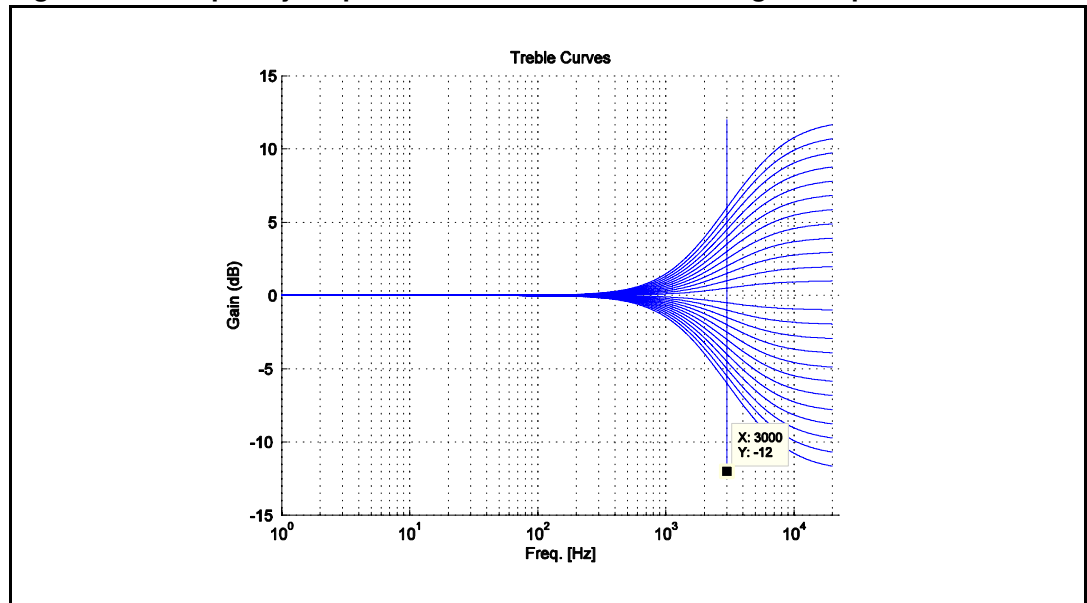

**Figure 24. Frequency responses of bass control at 1-dB gain steps**

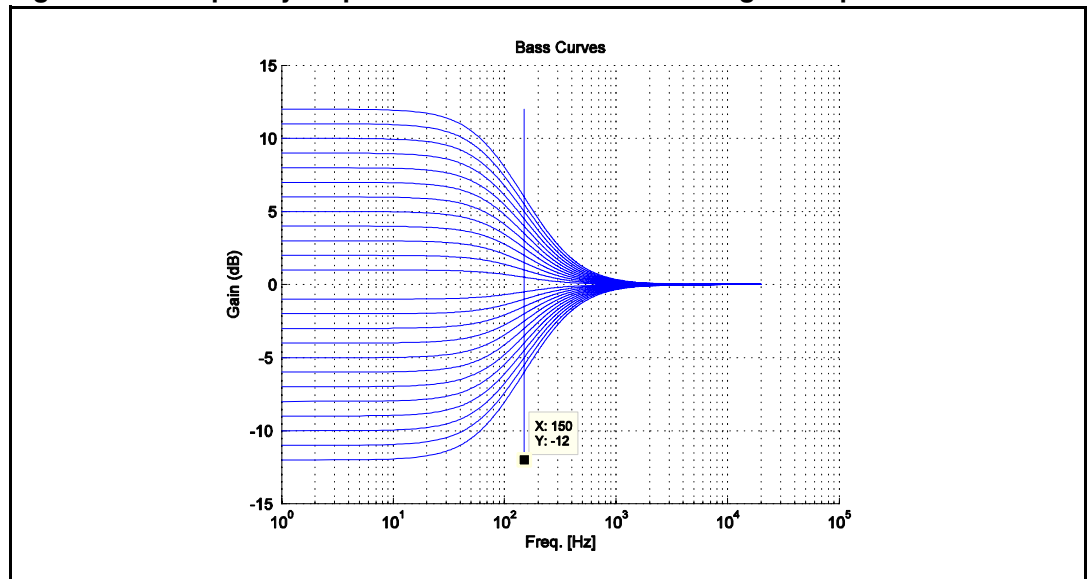

### 6.9.1 Configuration example

This is an example of the tone control register setup. It is assumed that every peripheral is already configured and working correctly.

[Table 21](#) gives the register values to obtain +12 dB of bass on all channels and -10 dB of treble on channels 0 and 1.

**Table 21. Selecting EQ curves**

Register - Address	Programmed value	Description
BASS_SEL0_R	0x38	CH0 +12 dB bass
BASS_SEL1_R	0x38	CH1 +12 dB bass
BASS_SEL2_R	0x38	CH2 +12 dB bass
BASS_SEL3_R	0x38	CH3 +12 dB bass
TREB_SEL0_R	0x22	CH0 -10 dB treble
TREB_SEL1_R	0xx22	CH1 - 10 dB treble

### 6.10 Programmable delay

Every channel, just after the biquads stage, is connected to a dedicated delay block.

The length of the delay is stored in RAM at location 0x128 and can vary from 0 to 35 samples. The corresponding time delay depends on the processing sampling frequency.

#### 6.10.1 Presets

The delay of every channel is set to 0.

### 6.11 Volume and mute control

The STA321 provides a flexible volume and mute control stage. Using the registers [VOLCH0](#) to [VOLCH3 on page 122](#) it is possible to set the volume for each channel individually from +36 dB to -105 dB with 0.5-dB steps.

There is a master volume control, register [MVOL on page 120](#), as well. The master volume adds an offset to all the individual volume settings.

The mute function offers the possibility to turn off the sound by reducing the volume setting to -127.5 dB. It could be activated in two ways:

- register [FFXCFG0 on page 82](#) provides a dedicated mute control for each channel.
- pin MUTE, driven by an external signal, puts all four channels into mute mode.

Register [VOLCFG on page 120](#) provides some flexibility to set how the mute and volume change procedures are applied. If bit SVOL\_ONx is activated the volume of channel x is changed gradually (soft volume or soft mute); using a ramp it starts from the current value and goes down to the target value or to -127.5 dB for mute. The slope of the ramp is set with the value TIM\_SVOL which represents how many samples are needed to achieve a 0.5-dB step.

$$t_{\text{STEP}} = 2^{\text{TIM\_SVOL}} / f_{\text{S}}$$

The ramp procedure ends when the target volume or mute level is reached. The time for the volume change is calculated as:

$$t_{\text{CHANGE}} = (\text{volume}_{\text{CURRENT}} - \text{volume}_{\text{TARGET}}) / 0.5 * t_{\text{STEP}}$$

If SVOL\_ONx is not used, the volume and mute are set instantaneously.

The STA321 also has the possibility to put the FFX into mute in the event of bad input data using register FFXCFG0. If bit BAD\_CKS\_M is set to 1 the FFX is muted when BICLK and LRCLK do not meet the specifications. If MIS\_BICK\_M is set to 1 the FFX is muted when BICLK is missing. The mute can be applied gradually or abruptly via bit BAD\_IN\_M.

## 6.12 Limiter (clamping)

The saturation stage provides an individual or a global limitation on the output signal amplitude such that if the signal is above the limiting value then it is truncated (clamped).

A 23-bit saturation value made up using registers SATCHxCFG1, SATCHxCFG2 and SATCHxCFG3 can be set for each channel x.

However, if bit 7 of register [SATCH0CFG1 on page 116](#) is set to 1, all the channels take the saturation value of channel 0 and ignore the individual settings.

## 6.13 FFX channel re-mapping

Figure 25. FFX re-mapping

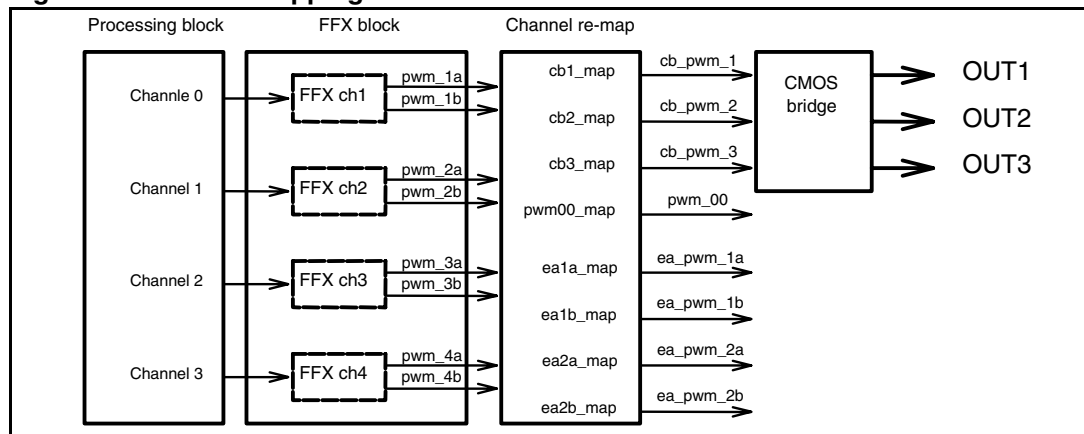

The channels are re-mapped through registers [PWMMAP1](#), [PWMMAP2](#) and [PWMMAP3 on page 86](#). The default configuration routes the channels directly to their respective CB/EA signals:

- pwm\_1a -> cb\_pwm\_1
- pwm\_1b -> cb\_pwm\_2
- pwm\_2a -> cb\_pwm\_3
- pwm\_2b -> pwm\_00 (PWM00)
- pwm\_3a -> ea\_pwm\_1 (EAPWM1)
- pwm\_3b -> ea\_pwm\_2 (EAPWM2)
- pwm\_4a -> ea\_pwm\_3 (EAPWM3)
- pwm\_4b -> ea\_pwm\_4 (EAPWM4)

## 6.14 Memory programming

Table 22 on page 47 shows the RAM mapping for the programmable functions in the signal processing stage. Changing or reading this data is done through the I<sup>2</sup>C interface in either single-word mode or in multi-word mode. Register PROCCTRL on page 107 sets the desired mode and whether to read or write:

- 1-word mode:  
this is for write only; the address of the memory location must be specified in registers START\_ADDR2 and START\_ADDR1 on page 108 and the value of the parameter must be written into registers I2CB0\_TOP, I2CB0\_MID and I2CB0\_BOT on page 102.
- 5-word mode:  
in this case it is possible to write/read 5 contiguous locations. Only the address of the first one must be specified in registers START\_ADD1-2, all the others are generated automatically. The values of the parameters must be placed in (or taken from) registers I2CB0\_TOP-BOT, I2CB1\_TOP-BOT, I2CB2\_TOP-BOT, I2CA1\_TOP-BOT, I2CA2\_TOP-BOT.

The 5-word mode is particular useful during the biquad programming when a set of five coefficients needs to be updated. Not only is it more efficient to change all of them at the same time but it avoids the generation of possible unpleasant acoustical side-effects.

The following sections explain how to implement this programming using the I<sup>2</sup>C interface.

### 6.14.1 Writing one coefficient/location to RAM

- Write RAM address to registers START\_ADDR2 and START\_ADDR1
- (b0) Write 8 MSBs of coefficient in register I2CB0\_TOP
- Write 8 middle bits of coefficient in register I2CB0\_MID
- Write 8 LSBs of coefficient in register I2CB0\_BOT
- Write 1 to bit W1 in register PROCCTRL.

Figure 26. Writing RAM location

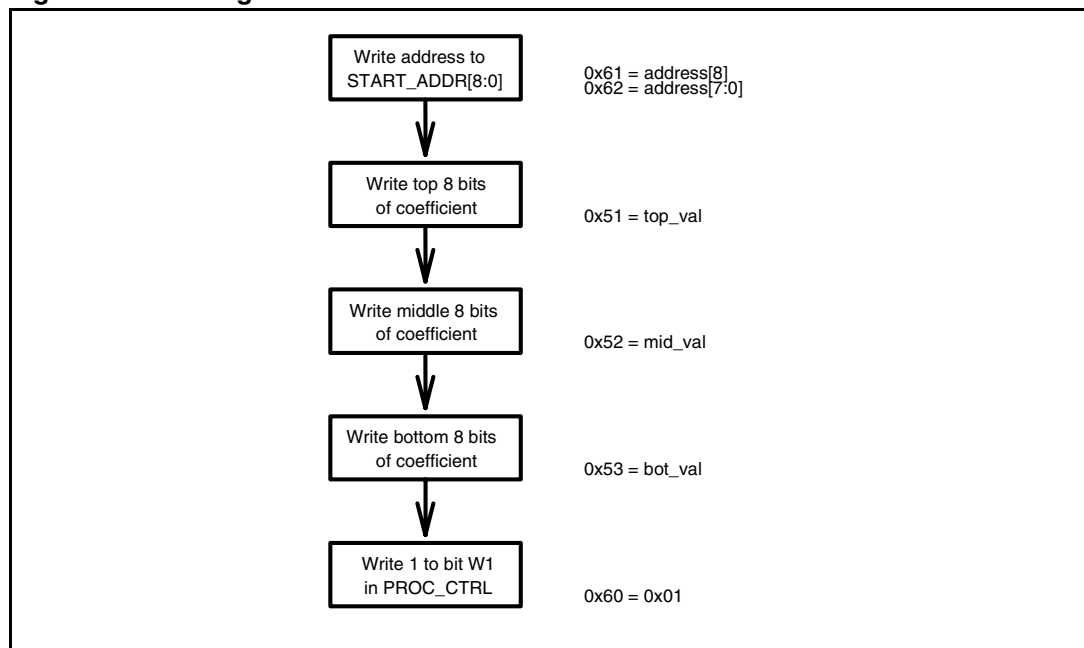

### 6.14.2 Writing a set of five coefficients/locations to RAM

- Write RAM address of b0 to registers *START\_ADDR2* and *START\_ADDR1*
- (b0) Write 8 MSBs of coefficient in register *I2CB0\_TOP*
- Write 8 middle bits of coefficient in register *I2CB0\_MID*
- Write 8 LSBs of coefficient in register *I2CB0\_BOT*
- (b1) Write 8 MSBs of coefficient in register *I2CB1\_TOP*
- Write 8 middle bits of coefficient in register *I2CB1\_MID*
- Write 8 LSBs of coefficient in register *I2CB1\_BOT*
- (b2) Write 8 MSBs of coefficient in register *I2CB2\_TOP*
- Write 8 middle bits of coefficient in register *I2CB2\_MID*
- Write 8 LSBs of coefficient in register *I2CB2\_BOT*
- (a1) Write 8 MSBs of coefficient in register *I2CA1\_TOP*
- Write 8 middle bits of coefficient in register *I2CA1\_MID*
- Write 8 LSBs of coefficient in register *I2CA1\_BOT*
- (a2) Write 8 MSBs of coefficient in register *I2CA2\_TOP*
- Write 8 middle bits of coefficient in register *I2CA2\_MID*
- Write 8 LSBs of coefficient in register *I2CA2\_BOT*
- Write 1 to bit WA in register *PROCCTRL*.

Figure 27. Writing five contiguous RAM locations

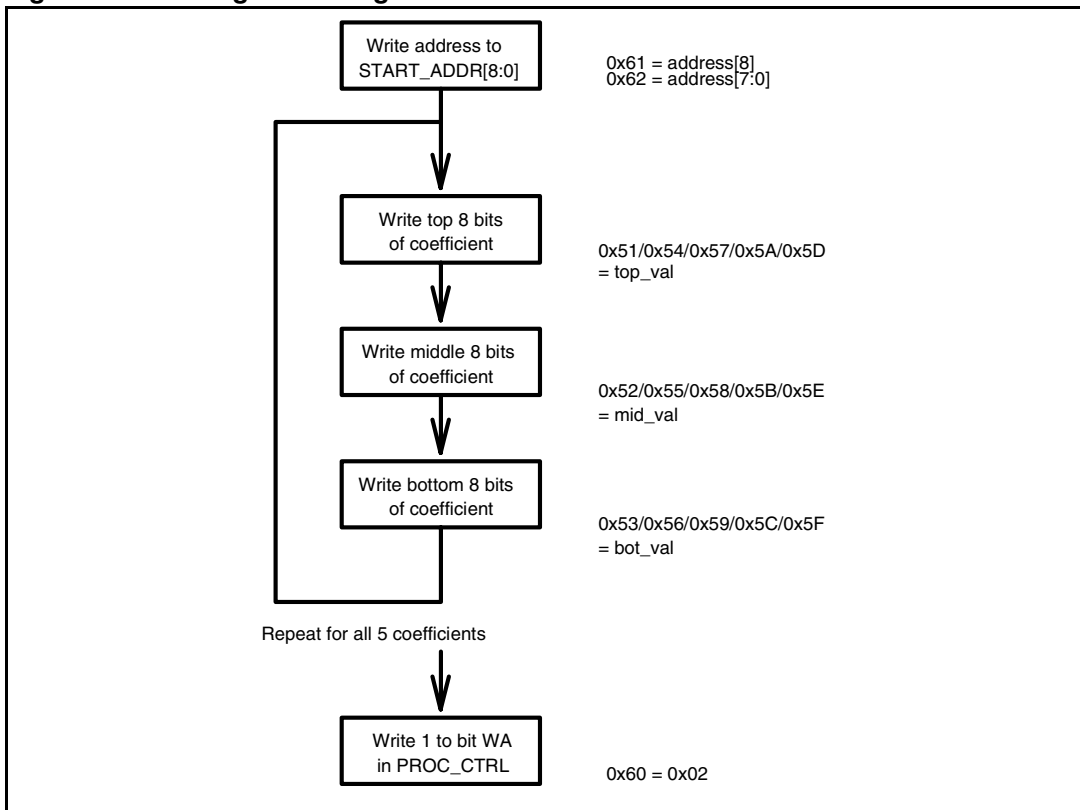

### 6.14.3 Reading a set of five coefficients/locations from RAM

- Write RAM address of b0 to registers *START\_ADDR2* and *START\_ADDR1*
- Write 1 to bit RA in register *PROCCTRL*
- (b0) Read 8 MSBs of coefficient in register *I2CB0\_TOP*
- Read 8 middle bits of coefficient in register *I2CB0\_MID*
- Read 8 LSBs of coefficient in register *I2CB0\_BOT*
- (b1) Read 8 MSBs of coefficient in register *I2CB1\_TOP*
- Read 8 middle bits of coefficient in register *I2CB1\_MID*
- Read 8 LSBs of coefficient in register *I2CB1\_BOT*
- (b2) Read 8 MSBs of coefficient in register *I2CB2\_TOP*
- Read 8 middle bits of coefficient in register *I2CB2\_MID*
- Read 8 LSBs of coefficient in register *I2CB2\_BOT*
- (a1) Read 8 MSBs of coefficient in register *I2CA1\_TOP*
- Read 8 middle bits of coefficient in register *I2CA1\_MID*
- Read 8 LSBs of coefficient in register *I2CA1\_BOT*
- (a2) Read 8 MSBs of coefficient in register *I2CA2\_TOP*
- Read 8 middle bits of coefficient in register *I2CA2\_MID*
- Read 8 LSBs of coefficient in register *I2CA2\_BOT*

**Figure 28. Reading five contiguous RAM locations**

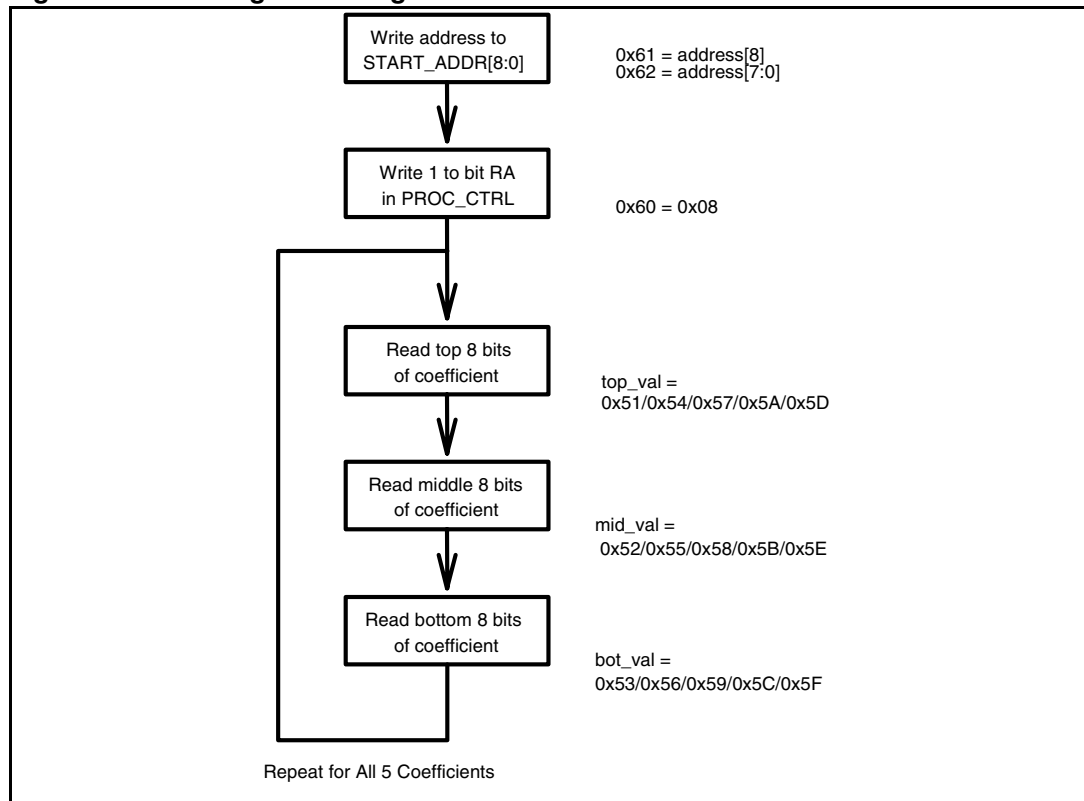

6.14.4 RAM mapping

Table 22. RAM mapping for processing stage

Addr	Descr.	Default	Block	Addr	Descr.	Default	Block
0x000	ch0i	0x7FFFFFFF	Pre mix: ch0	0x021	#2 a2	0x000000	(Ch0-biquad)
0x001	ch1i	0x000000		0x022	#2 a1	0x000000	
0x002	ch2i	0x000000		0x023	#3 b0	0x400000	
0x003	ch3i	0x000000		0x024	#3 b1	0x000000	
0x004	ch0i	0x000000	Pre mix: ch1	0x025	#3 b2	0x000000	
0x005	ch1i	0x7FFFFFFF		0x026	#3 a2	0x000000	
0x006	ch2i	0x000000		0x027	#3 a1	0x000000	
0x007	ch3i	0x000000		0x028	#3 b0	0x400000	
0x008	ch0i	0x000000	Pre mix: ch2	0x029	#4 b1	0x000000	
0x009	ch1i	0x000000		0x02A	#4 b2	0x000000	
0x00A	ch2i	0x7FFFFFFF		0x02B	#4 a2	0x000000	
0x00B	ch3i	0x000000		0x02C	#4 a1	0x000000	
0x00C	ch0i	0x000000	Pre mix: ch3	0x02D	#5 b0	0x400000	
0x00D	ch1i	0x000000		0x02E	#5 b1	0x000000	
0x00E	ch2i	0x000000		0x02F	#5 b2	0x000000	
0x00F	ch3i	0x7FFFFFFF		0x030	#5 a2	0x000000	
0x010	ch0	0x7FFFFFFF	Pre scaler	0x031	#5 a1	0x000000	
0x011	ch1	0x7FFFFFFF		0x032	#6 b0	0x400000	
0x012	ch2	0x7FFFFFFF		0x033	#6 b1	0x000000	
0x013	ch3	0x7FFFFFFF		0x034	#6 b2	0x000000	
0x014	#0 b0	0x400000	Ch0-biquad	0x035	#6 a2	0x000000	
0x015	#0 b1	0x000000		0x036	#6 a1	0x000000	
0x016	#0 b2	0x000000		0x037	#7 b0	0x400000	
0x017	#0 a2	0x000000		0x038	#7 b1	0x000000	
0x018	#0 a1	0x000000		0x039	#7 b2	0x000000	
0x019	#1 b0	0x400000		0x03A	#7 a2	0x000000	
0x01A	#1 b1	0x000000		0x03B	#7 a1	0x000000	
0x01B	#1 b2	0x000000		0x03C	#8 b0	0x400000	
0x01C	#1 a2	0x000000		0x03D	#8 b1	0x000000	
0x01D	#1 a1	0x000000		0x03E	#8 b2	0x000000	
0x01E	#2 b0	0x400000		0x03F	#8 a2	0x000000	
0x01F	#2 b1	0x000000		0x040	#8 a1	0x000000	
0x020	#2 b2	0x000000		0x041	#9 b0	0x400000	

**Table 22. RAM mapping for processing stage (continued)**

Addr	Descr.	Default	Block	Addr	Descr.	Default	Block
0x042	#9 b1	0x000000	(Ch0-biquad)	0x065	#3 b1	0x000000	
0x043	#9 b2	0x000000		0x066	#3 b2	0x000000	
0x044	#9 a2	0x000000		0x067	#3 a2	0x000000	
0x045	#9 a1	0x000000		0x068	#3 a1	0x000000	
0x046	#10 b0	0x400000		0x069	#3 b0	0x400000	
0x047	#10 b1	0x000000		0x06A	#4 b1	0x000000	
0x048	#10 b2	0x000000		0x06B	#4 b2	0x000000	
0x049	#10 a2	0x000000		0x06C	#4 a2	0x000000	
0x04A	#10 a1	0x000000		0x06D	#4 a1	0x000000	
0x04B	#11 b0	0x400000		0x06E	#5 b0	0x400000	
0x04C	#11 b1	0x000000		0x06F	#5 b1	0x000000	
0x04D	#11 b2	0x000000		0x070	#5 b2	0x000000	
0x04E	#11 a2	0x000000		0x071	#5 a2	0x000000	
0x04F	#11 a1	0x000000		0x072	#5 a1	0x000000	
0x050	#12 b0	0x400000		0x073	#6 b0	0x400000	
0x051	#12 b1	0x000000		0x074	#6 b1	0x000000	
0x052	#12 b2	0x000000		0x075	#6 b2	0x000000	
0x053	#12 a2	0x000000		0x076	#6 a2	0x000000	
0x054	#12 a1	0x000000		0x077	#6 a1	0x000000	
0x055	#0 b0	0x400000		Ch1-biquad	0x078	#7 b0	
0x056	#0 b1	0x000000	0x079		#7 b1	0x000000	
0x057	#0 b2	0x000000	0x07A		#7 b2	0x000000	
0x058	#0 a2	0x000000	0x07B		#7 a2	0x000000	
0x059	#0 a1	0x000000	0x07C		#7 a1	0x000000	
0x05A	#1 b0	0x400000	0x07D		#8 b0	0x400000	
0x05B	#1 b1	0x000000	0x07E		#8 b1	0x000000	
0x05C	#1 b2	0x000000	0x07F		#8 b2	0x000000	
0x05D	#1 a2	0x000000	0x080		#8 a2	0x000000	
0x05E	#1 a1	0x000000	0x081		#8 a1	0x000000	
0x05F	#2 b0	0x400000	0x082		#9 b0	0x400000	
0x060	#2 b1	0x000000	0x083		#9 b1	0x000000	
0x061	#2 b2	0x000000	0x084		#9 b2	0x000000	
0x062	#2 a2	0x000000	0x085		#9 a2	0x000000	
0x063	#2 a1	0x000000	0x086		#9 a1	0x000000	
0x064	#3 b0	0x400000	0x087		#10 b0	0x400000	

**Table 22. RAM mapping for processing stage (continued)**

Addr	Descr.	Default	Block	Addr	Descr.	Default	Block
0x088	#10 b1	0x000000	(Ch1-biquad)	0x0AB	#4 b1	0x000000	(Ch2-biquad)
0x089	#10 b2	0x000000		0x0AC	#4 b2	0x000000	
0x08A	#10 a2	0x000000		0x0AD	#4 a2	0x000000	
0x08B	#10 a1	0x000000		0x0AE	#4 a1	0x000000	
0x08C	#11 b0	0x400000		0x0AF	#5 b0	0x400000	
0x08D	#11 b1	0x000000		0x0B0	#5 b1	0x000000	
0x08E	#11 b2	0x000000		0x0B1	#5 b2	0x000000	
0x08F	#11 a2	0x000000		0x0B2	#5 a2	0x000000	
0x090	#11 a1	0x000000		0x0B3	#5 a1	0x000000	
0x091	#12 b0	0x400000		0x0B4	#6 b0	0x400000	
0x092	#12 b1	0x000000		0x0B5	#6 b1	0x000000	
0x093	#12 b2	0x000000		0x0B6	#6 b2	0x000000	
0x094	#12 a2	0x000000		0x0B7	#6 a2	0x000000	
0x095	#12 a1	0x000000		0x0B8	#6 a1	0x000000	
0x096	#0 b0	0x400000		Ch2-biquad	0x0B9	#7 b0	
0x097	#0 b1	0x000000	0x0BA		#7 b1	0x000000	
0x098	#0 b2	0x000000	0x0BB		#7 b2	0x000000	
0x099	#0 a2	0x000000	0x0BC		#7 a2	0x000000	
0x09A	#0 a1	0x000000	0x0BD		#7 a1	0x000000	
0x09B	#1 b0	0x400000	0x0BE		#8 b0	0x400000	
0x09C	#1 b1	0x000000	0x0BF		#8 b1	0x000000	
0x09D	#1 b2	0x000000	0x0C0		#8 b2	0x000000	
0x09E	#1 a2	0x000000	0x0C1		#8 a2	0x000000	
0x09F	#1 a1	0x000000	0x0C2		#8 a1	0x000000	
0x0A0	#2 b0	0x400000	0x0C3		#9 b0	0x400000	
0x0A1	#2 b1	0x000000	0x0C4		#9 b1	0x000000	
0x0A2	#2 b2	0x000000	0x0C5		#9 b2	0x000000	
0x0A3	#2 a2	0x000000	0x0C6		#9 a2	0x000000	
0x0A4	#2 a1	0x000000	0x0C7		#9 a1	0x000000	
0x0A5	#3 b0	0x400000	0x0C8	#10 b0	0x400000		
0x0A6	#3 b1	0x000000	0x0C9	#10 b1	0x000000		
0x0A7	#3 b2	0x000000	0x0CA	#10 b2	0x000000		
0x0A8	#3 a2	0x000000	0x0CB	#10 a2	0x000000		
0x0A9	#3 a1	0x000000	0x0CC	#10 a1	0x000000		
0x0AA	#3 b0	0x400000	0x0CD	#11 b0	0x400000		

**Table 22. RAM mapping for processing stage (continued)**

Addr	Descr.	Default	Block	Addr	Descr.	Default	Block
0x0CE	#11 b1	0x000000	(Ch2-biquad)	0x0F1	#5 b1	0x000000	
0x0CF	#11 b2	0x000000		0x0F2	#5 b2	0x000000	
0x0D0	#11 a2	0x000000		0x0F3	#5 a2	0x000000	
0x0D1	#11 a1	0x000000		0x0F4	#5 a1	0x000000	
0x0D2	#12 b0	0x400000		0x0F5	#6 b0	0x400000	
0x0D3	#12 b1	0x000000		0x0F6	#6 b1	0x000000	
0x0D4	#12 b2	0x000000		0x0F7	#6 b2	0x000000	
0x0D5	#12 a2	0x000000		0x0F8	#6 a2	0x000000	
0x0D6	#12 a1	0x000000		0x0F9	#6 a1	0x000000	
0x0D7	#0 b0	0x400000		0x0FA	#7 b0	0x400000	
0x0D8	#0 b1	0x000000	0x0FB	#7 b1	0x000000		
0x0D9	#0 b2	0x000000	0x0FC	#7 b2	0x000000		
0x0DA	#0 a2	0x000000	0x0FD	#7 a2	0x000000		
0x0DB	#0 a1	0x000000	0x0FE	#7 a1	0x000000		
0x0DC	#1 b0	0x400000	0x0FF	#8 b0	0x400000		
0x0DD	#1 b1	0x000000	0x100	#8 b1	0x000000		
0x0DE	#1 b2	0x000000	0x101	#8 b2	0x000000		
0x0DF	#1 a2	0x000000	0x102	#8 a2	0x000000		
0x0E0	#1 a1	0x000000	0x103	#8 a1	0x000000		
0x0E1	#2 b0	0x400000	0x104	#9 b0	0x400000	(Ch3-biquad)	
0x0E2	#2 b1	0x000000	0x105	#9 b1	0x000000		
0x0E3	#2 b2	0x000000	0x106	#9 b2	0x000000		
0x0E4	#2 a2	0x000000	0x107	#9 a2	0x000000		
0x0E5	#2 a1	0x000000	0x108	#9 a1	0x000000		
0x0E6	#3 b0	0x400000	0x109	#10 b0	0x400000		
0x0E7	#3 b1	0x000000	0x10A	#10 b1	0x000000		
0x0E8	#3 b2	0x000000	0x10B	#10 b2	0x000000		
0x0E9	#3 a2	0x000000	0x10C	#10 a2	0x000000		
0x0EA	#3 a1	0x000000	0x10D	#10 a1	0x000000		
0x0EB	#3 b0	0x400000	0x10E	#11 b0	0x400000	(Ch3-biquad)	
0x0EC	#4 b1	0x000000	0x10F	#11 b1	0x000000		
0x0ED	#4 b2	0x000000	0x110	#11 b2	0x000000		
0x0EE	#4 a2	0x000000	0x111	#11 a2	0x000000		
0x0EF	#4 a1	0x000000	0x112	#11 a1	0x000000		
0x0F0	#5 b0	0x400000	0x113	#12 b0	0x400000		

Table 22. RAM mapping for processing stage (continued)

Addr	Descr.	Default	Block	Addr	Descr.	Default	Block
0x114	#12 b1	0x000000	(Ch3-biquad)	0x120	ch0i	0x000000	Post mix: ch2
0x115	#12 b2	0x000000		0x121	ch1i	0x000000	
0x116	#12 a2	0x000000		0x122	ch2i	0x7FFFFFFF	
0x117	#12 a1	0x000000		0x123	ch3i	0x000000	
0x118	ch0i	0x7FFFFFFF	Post mix: ch0	0x124	ch0i	0x000000	Post mix: ch3
0x119	ch1i	0x000000		0x125	ch1i	0x000000	
0x11A	ch2i	0x000000		0x126	ch2i	0x000000	
0x11B	ch3i	0x000000		0x127	ch3i	0x7FFFFFFF	
0x11C	ch0i	0x000000	Post mix: ch1	0x128	delay	0x000000	Delay
0x11D	ch1i	0x7FFFFFFF		-	-	-	-
0x11E	ch2i	0x000000		-	-	-	-
0x11F	ch3i	0x000000		-	-	-	-

## 7 FFX

### 7.1 Functional description

Figure 29. FFX processing schematic

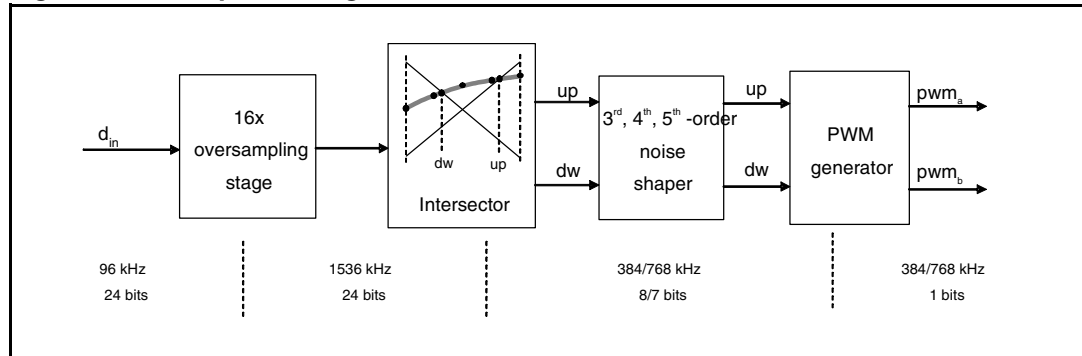

The FFX modulator is a digital low-distortion low-noise PCM-to-PWM converter, based on a pseudo-natural sampling technique, which converts the 4 by 24-bit digital inputs into differential pulse-width modulated outputs at a frequency of either 384 or 768 kHz (selected by register [FFXCFG2](#), bit PWM\_FREQ) and with a time resolution of 98.304 MHz. This gives a dynamic range that is approaching 100 dB.

The signal is compared with two different carrier signals (rising and falling sawtooth waveforms at the PWM frequency), to get a double edge modulation and to have the possibility to drive a differential (full bridge) power stage.

The order of the noise shaper can be modified by the user, via register bit [FFXCFG2.NS\\_ORD](#), depending on the acceptable amount of noise out of the audio band, that is, noise above 20 kHz. The higher the noise shaper order, the better is the SNR but the higher is the out of band noise.

The PWM generator block converts the amplitude quantization into time quantization to generate a PWM signal.

### 7.2 Modulation schemes

It is possible to use each of the two intersections with up-carrier and down-carrier to force a rising or a falling edge on each of the two PWM outputs (A and B). This flexibility is achieved through programming registers PWMOnCFG1-2 (where n is the number, 1 to 4, of the output) beginning [on page 91](#).

PWM output A can be modulated in one of, or a hybrid of, two basic ways via bits PM\_nA:

- with the wave starting from level 0 at the beginning of the period, and rising to level 1 when the audio signal intersects the down-carrier
- with the wave starting from level 1 at the beginning of the period, and falling to level 0 when the audio signal intersects the up-carrier;

PWM output B can be similarly modulated via bits PM\_nB:

- with the wave starting from level 1 at the beginning of the period, and falling to level 0 when the audio signal intersects the down-carrier;
- with the wave starting from level 0 at the beginning of the period, and rising to level 1 when the audio signal intersects the up-carrier;

The hybrid mode is the toggling between the two methods of modulation for each PWM period.

**Figure 30. PWM modes for outputs A and B**

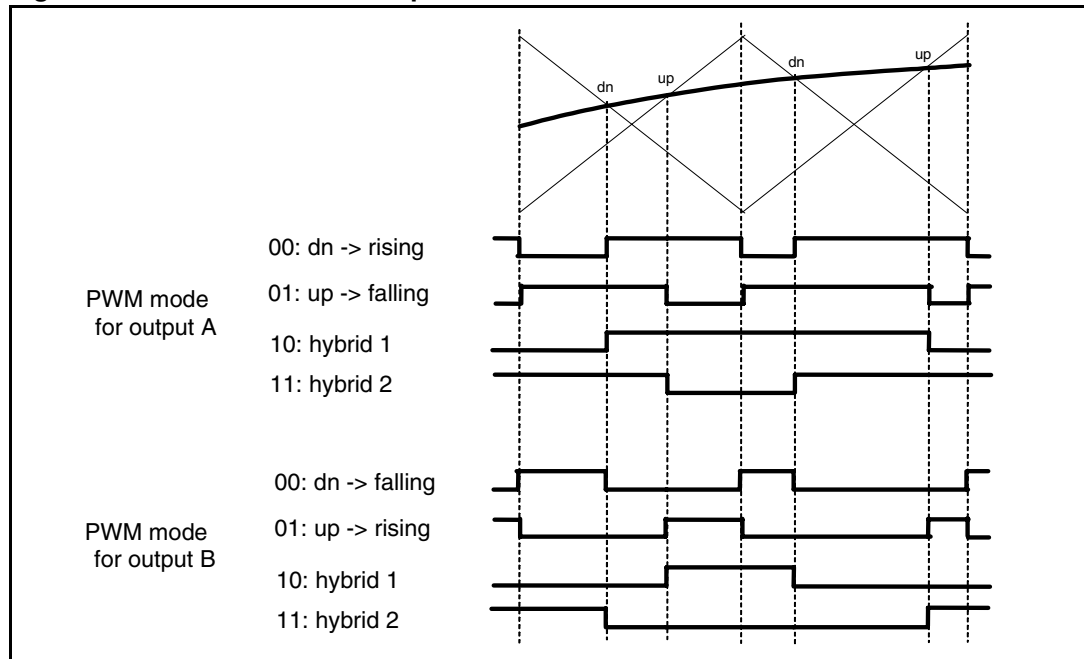

The various single output modulation schemes can be combined together on the two outputs to get the desired differential modulation schemes.

In particular, for the traditional schemes (binary, phase shift), and the new one (new phase shift modulation) the mode bits must be set according to [Table 23](#) below.

**Table 23. Modulation type with register programming**

Register bit PWMonCFG1.PM_nA	Register bit PWMonCFG2.PM_nB	Resulting modulation
00	00	binary
01	01	
10	10	phase shift
11	11	
00	01	new phase shift
01	00	

**Figure 31. Modulation waveforms corresponding to [Table 23](#)**

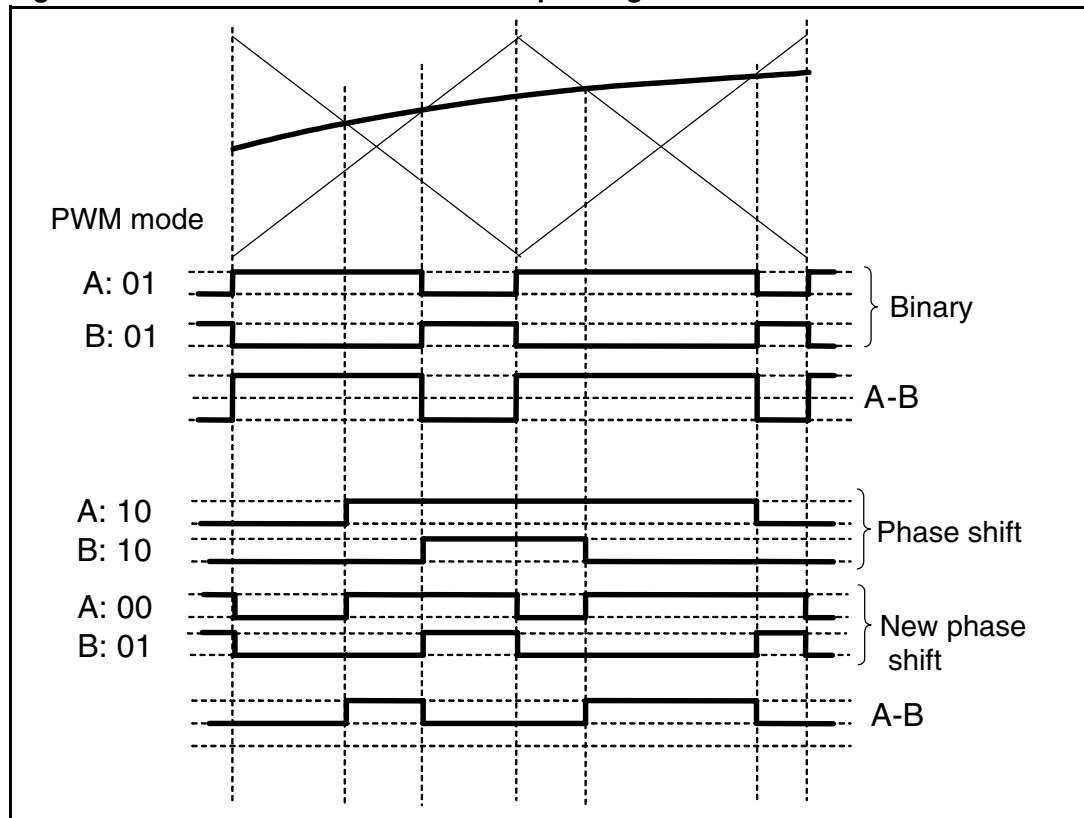

### 7.3 PWM shift feature

In new phase shift modulation it is possible to shift one output with respect to the other one. This can reduce the noise generated by the simultaneous switching of two or more outputs. The shift is performed through by programming bits PS\_nA and PS\_nB in registers PWMOnCFG1-2 (where n is the number, 1 to 4, of the output) beginning [on page 91](#).

**Figure 32. New phase shift modulation with shift feature**

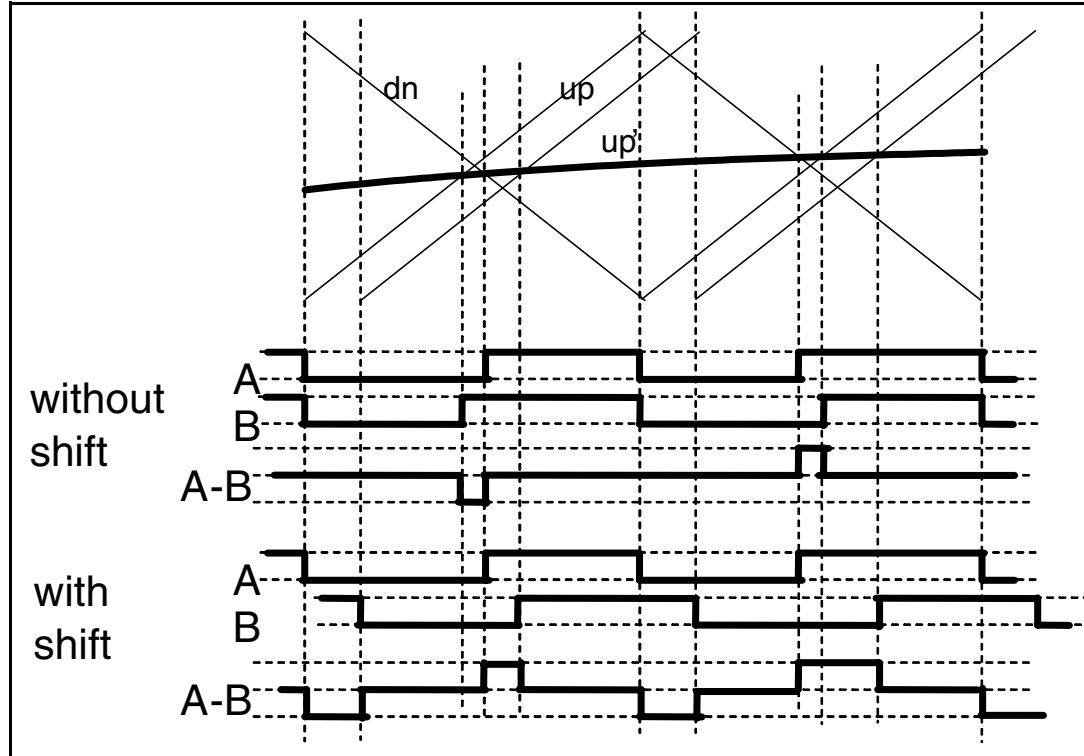

### 7.4 Ternary mode

The ternary mode feature is also available. It is activated by bits TERNARY\_n in registers PWMonCFG0 beginning [on page 91](#) (where n is the number, 1 to 4, of the output).

This feature overrides the PWM mode bits settings PM\_nA and PM\_nB.

**Figure 33. Ternary modulation**

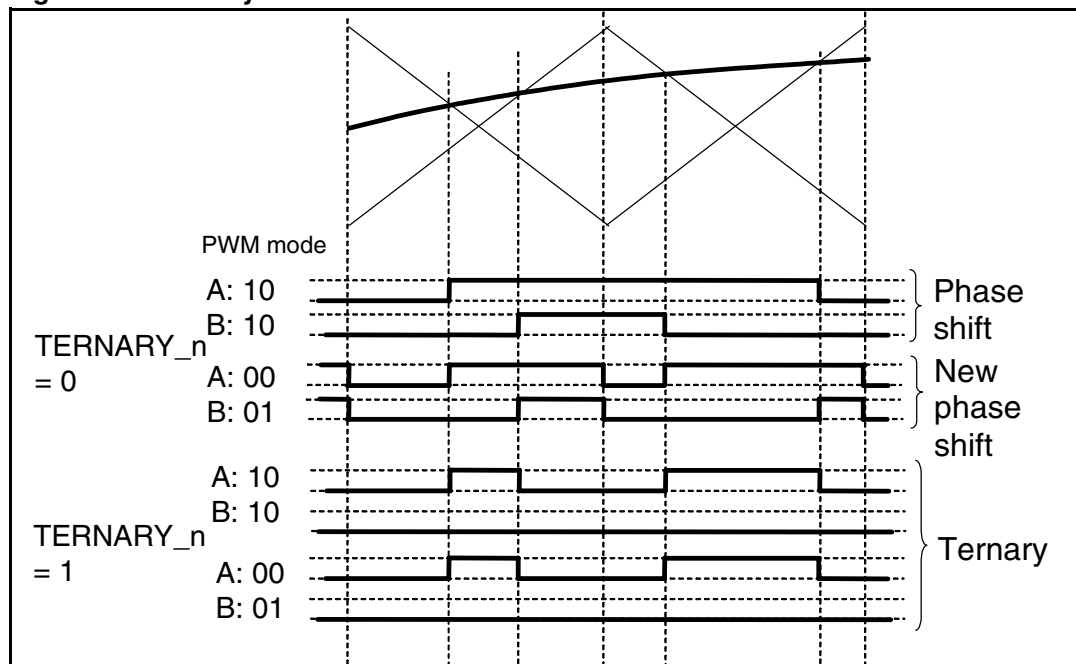

### 7.5 Minimum pulse limitation

The FFX modulator has a minimum pulse limitation feature which has a double purpose:

- to limit the maximum/minimum duty cycle when the audio signal is near to full scale;
- to have the commutations on the same channel outputs A and B separated by a minimum pulse distance.

The first feature is always enabled.

The second feature is enabled with register bit PWMonCFG0.MP\_ZERO\_n, where n is the output 1 to 4. It is possible to prevent the commutations on outputs A and B to happen exactly at the same time using bit AZPLS\_n. The minimum pulse size is determined by the number of system clock (98.304 MHz) periods programmed in bits MIN\_PLS\_n[3:0].

## 7.6 Headphone modulation

The FFX modulator can be used for driving a headphone load with the common terminal available, together with left and right terminals.

In this case it is possible to drive the common terminal with a 50% fixed duty cycle square wave coming from output B of the modulator, by setting bit HALFB\_n to 1, and the left and right terminals from the output A of two different channels. For the three outputs used in this way bits PM\_nA and PM\_nB can be 00 or 01.

**Figure 34. Modulation for headphones**

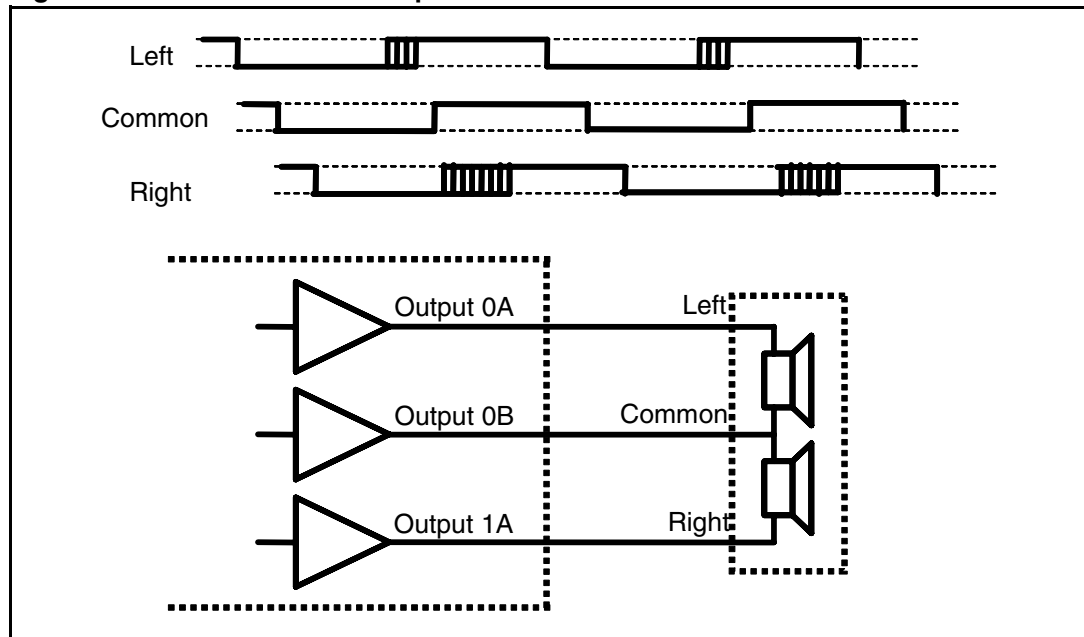

## 7.7 pfStart™ operation

In order to avoid pop noise the bypass capacitor, situated between the filtered amplifier output and the load in single-ended applications, needs to be pre-charged to half of the power supply voltage. This is usually done by connecting a resistive partition to the output and then disconnecting it at the end of the charging phase (see the analog pop free description in section 9).

In the STA321 the FFX digital pop-free feature allows the digital pre-charging of the bypass capacitor using the amplifier instead of a resistive partition. This active pre-charge is also faster than the resistive partition method. The digital pop-free function can be independently set on both power stages, that is, the CMOS bridge stage using bit CB\_PFDIG and the embedded amplifier stage using bit EA\_PFDIG in register *FFXCFG2* on page 83.

Registers CB\_PFRAMP1-6 beginning on page 97 and EA\_PFRAMP1-6 beginning on page 99 control the charging function. The register usage is given in the following description.

The capacitor is charged from zero to half the supply voltage with the PWM signal. By applying a suitable ramp to the input of the modulator the PWM signal begins from near 0% duty cycle to 50% duty cycle.

The method is based on a slow ramp signal (from ground to  $V_{CC} / 2$ ), implemented using both pulse density modulation (PDM) and pulse width modulation (PWM). At the beginning of the ramp PDM is used starting from an initial value set by bits CBRMPINI and EARMPINI, and then switching to PWM when reaching a threshold value set by bits CBRMPH and EARMPH.

The total ramp time can be modified via bits EATIM\_RMP and CBTIM\_RMP.

**Figure 35. Digital pop-free ramp implementation**

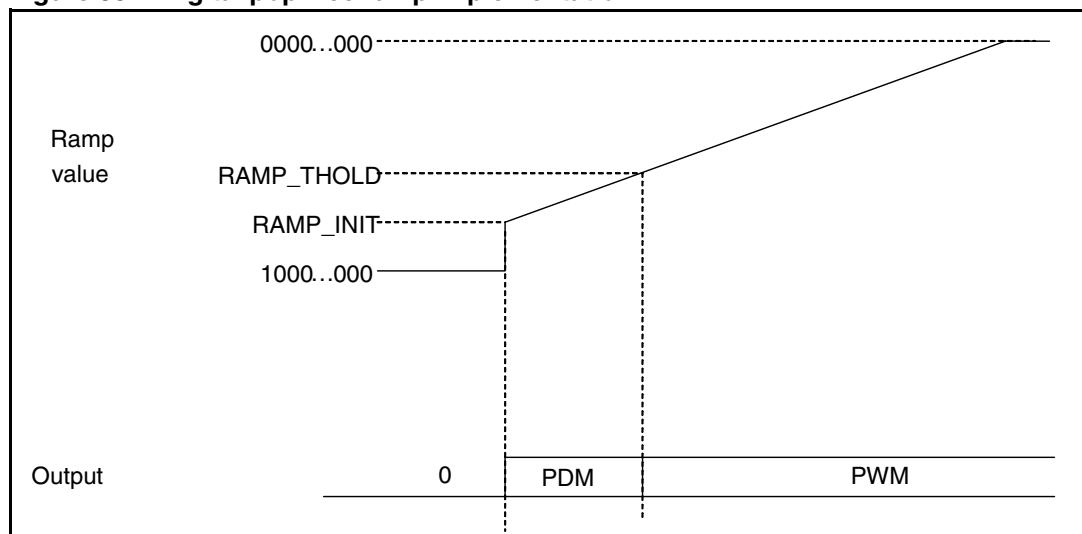

The PDM is realized with a noise shaper circuit, where the sampling time ( $T_d$ ) of the noise shaper is equal to the minimum pulse size set by bits CBRMP\_MP and EARMP\_MP.

## 7.8 PWM00 output

Pin PWM00 is an additional output with a maximum driving capability of 2 mA to control an external bridge or external operational amplifier.

By default, PWM00 is tied to logical 0. When register bit CKOCFG[0] is set to 1 then any FFX PWM channel output can be mapped to it.

When the CMOS bridge is in standby the output PWM00 is, by default, turned off. However, it is possible to have the FFX signal PWM3A as the PWM00 output by using bit 3 of register [FFXCFG0 on page 82](#), and this whatever the status of power-down or the 3-state signals of both bridges, even if they are different from the normal operating mode where the output is 0 when in power-down or 3-state mode.

## 8 CMOS power stage

The CMOS half-bridge circuit of [Figure 36](#) is a single channel analog output power stage. There are three such output stages in the STA321, one for each of the outputs OUT1-3.

The switching mode is regulated by the logic circuit which ensures that the MOSFETs are switched in such a way as to avoid (or minimize) conditions where both the PMOS and the NMOS are conducting at the same time.

The input is a 1.8-V to 3.3-V level shifter followed by some combinational logic.

**Figure 36. CMOS half bridge block diagram**

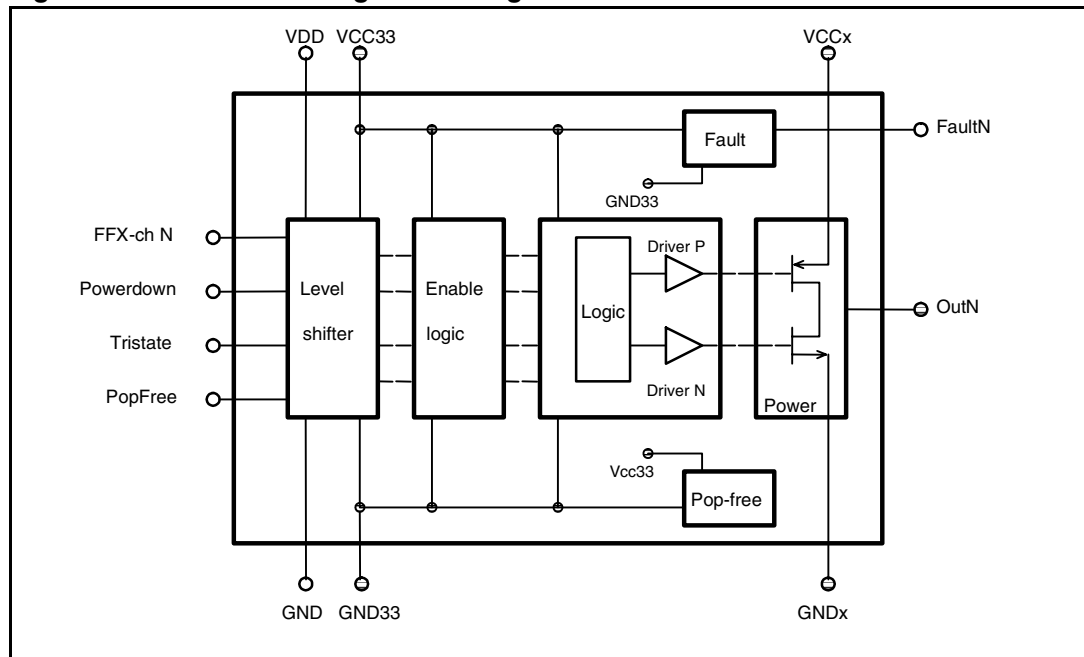

**Table 24. CMOS bridge signal descriptions**

Pin Name	Direction	Description
FFX-ch	In	Digital audio signal coming from FFX block
Powerdown	In	Powerdown signal coming from the FFX block
Tristate	In	3-state signal from the FFX block
PopFree	In	Pop-free signal from the FFX block
Fault	Out	Short-circuit fault output feedback signal to digital core (active low)
Out	Out	Channel half-bridge analog output
VCC33/GND33	Supply	Pre-driver analog supply
VDD/GND	Supply	Digital core supply generated by internal regulator
VCCx/GNDx	Supply	Half-bridge power supply

The CMOS bridge power rating can be calculated using the following formulas:

$$P (<1\%) = (R_L / 2) * (M * VCC / 2 / (R_L + 2 * R_{DS}))^2 \text{ for BTL}$$

$$P (<1\%) = (R_L / 2) * (M * VCC / 2 / (R_L + R_{DS}))^2 \text{ for single ended}$$

$$P (10\%) = 1.28 * P(<1\%)$$

where  $R_{DS}$  is composed of the MOST  $R_{DSON}$  and the board and connector parasitic resistances (including power supplies and coils) and  $M$  is the modulation index obtained from

$$M = 1 - 2 * (MIN\_PLS\_n + 1) / f_{clk\_ffx} / \tau_S$$

where  $MIN\_PLS\_n$  is the value in register PWMOnCFG0 for channel  $n$ ,  $f_{clk\_ffx}$  is the frequency of the FFX clock and  $\tau_S$  is the PWM clock period (384 kHz or 768 kHz selected by register bit [FFXCFG2.PWM\\_FREQ](#)).

For the CMOS bridge,  $MIN\_PLS\_n$  can be set to 0; this gives  $M = 0.9922$ .

**Table 25. Power output (at 1% THD) in headphone mode**

Load, $R_L$ in $\Omega$	Power, $P$ in mW (for 3.3-V supply)
16	70
32	32

The analog pop\_free function is available in the CMOS bridge circuit by setting the appropriate bridge start-up as per [Table 26](#). The CMOS bridge enable and pop-free signals are generated from the three signals Powerdown, Tristate and PopFree provided by the digital core and controlled/configured through register bits [FFXCFG1.CB\\_STBY](#), [FFXCFG1.CB\\_TRISTn](#) and [PFEFAULT.PFE](#) $n$  for the three outputs,  $n = 1$  to 3.

**Figure 37. Analog pop-free schematic**

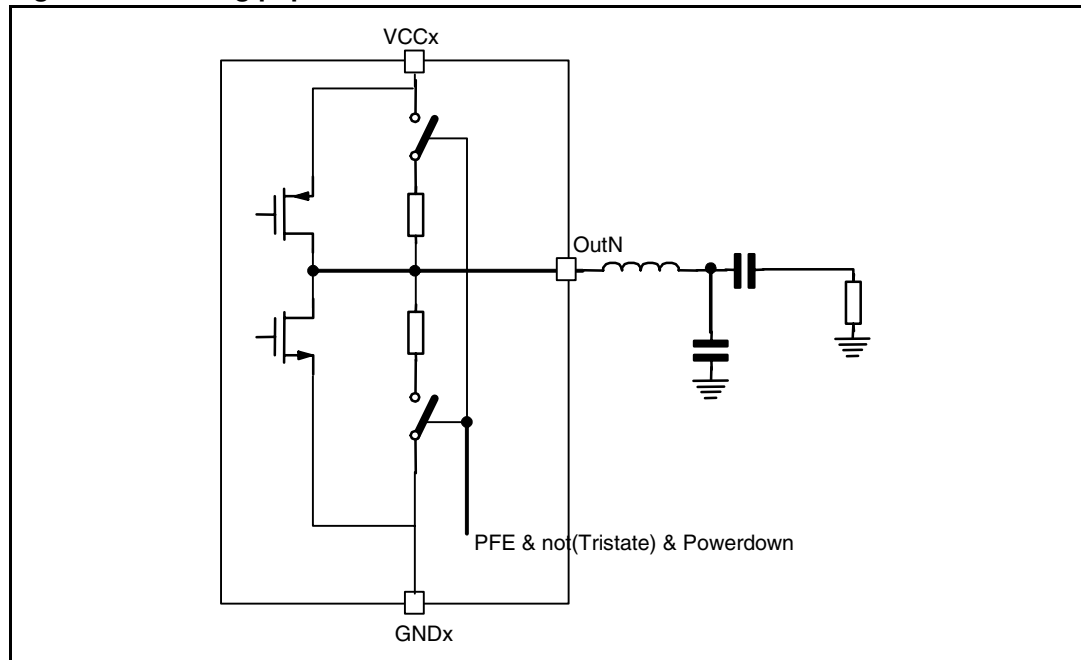

**Table 26. Logic circuit at bridge input**

Powerdown	Tristate	PopFree	Pop-free resistors	Bridge status
0	0	0	Disconnected	3-state
0	0	1	Disconnected	3-state
1	0	1	Connected	3-state
1	1	1	Disconnected	On
1	1	0	Disconnected	On

At the appropriate time the two pop-free resistors allow the bypass capacitor to be charged to  $V_{CCx} / 2$ . The STA321 generates automatically the bridge start-up and switch-off sequence to provide the correct charging. The time TT in *Figure 38* below is set using registers CBTTF0-1 and CBTTP0-1. TT must be chosen for the specific application depending on the decoupling capacitor, load and power supply.

After powerdown is applied again the decoupling capacitor discharges slowly due to capacitor leakage.

The analog pop-free implementation cannot be used with the digital pfStart implementation

Both analog and digital pop-free features must be disabled if binary headphone modulation is used.

**Figure 38. Analog pop-free start-up and switch-off sequence**

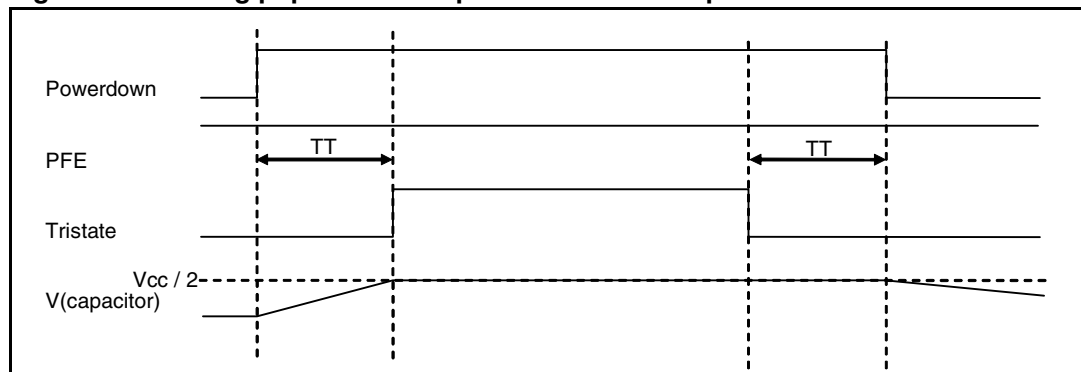

The CMOS bridge circuit includes over-current protection. The FAULT signal indicates to the output the status of the over-current condition due to a short circuit. The over-current thresholds detected by the CMOS bridge are fixed at 1.8 A.

## 9 Fault detection and recovery

### 9.1 External amplifier

When Fault is reported on pin EAFTN and bit EA\_TSFT\_ON of register [FFXCFG2 on page 83](#) is active, then pin EATSN is reset to 0 and the embedded bridge outputs are put in the high-impedance state. When the fault signal disappears (that is, goes to 1) the embedded bridge is kept in 3-state for a time defined in register EATTF0-1 [on page 86](#), after which time the outputs recover.

### 9.2 CMOS bridge

When Fault is reported to the digital core and CB\_TSFT\_ON of register [FFXCFG2 on page 83](#) is active then the tristate is activated thus putting the STA321 OUTn outputs in the high-impedance state. When the fault signal disappears, the CMOS bridge is kept in 3-state status for a time defined in register CBTTF0-1 [on page 88](#), after which time the outputs recover.

# 10 ADC

## 10.1 Description

The STA321 analog input is provided through a low-power, low-voltage complete low-cost analog-to-digital converter front end designed for stereo audio applications. It includes programmable gain amplifier, anti-aliasing filter, low-noise microphone biasing circuit, a third order MASH2-1 delta-sigma modulator, a digital decimating filter and a 1st-order DC-removal filter.

The ADC works with either a microphone input or a line input, selected using bit ADC\_INSEL in register [ADCCFG0 on page 133](#).

A programmable gain amplifier (PGA) is available in microphone-in mode giving the possibility to amplify the signal from 0 to 42 dB in steps of 6 dB using register bit [ADCCFG0.ADC\\_PGA](#).

The ADC specifications are given in [Table 6 on page 14](#).

**Figure 39. ADC front-end block diagram**

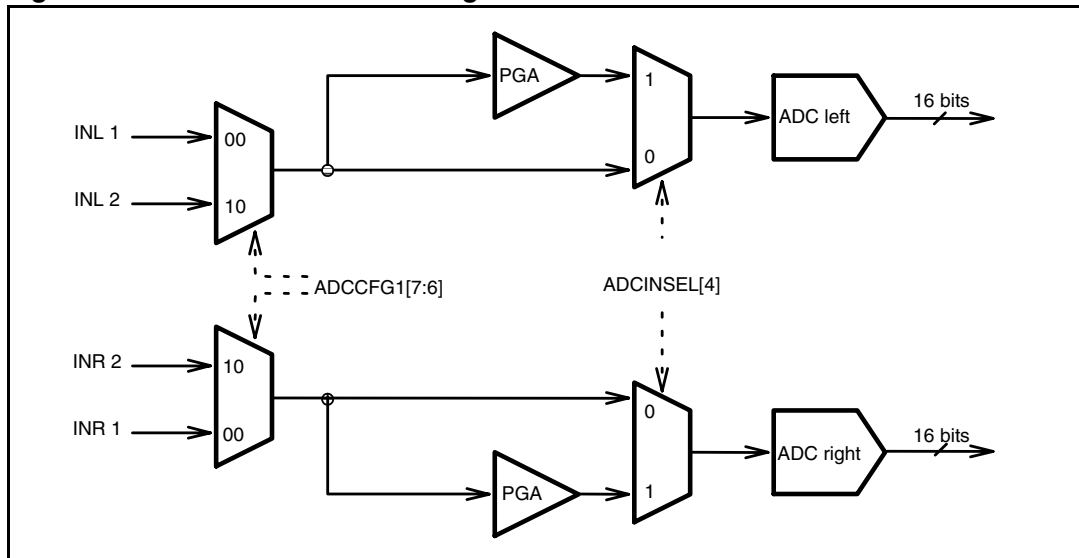

## 10.2 Application schematic

Figure 40. Typical connections for power supplies and inputs

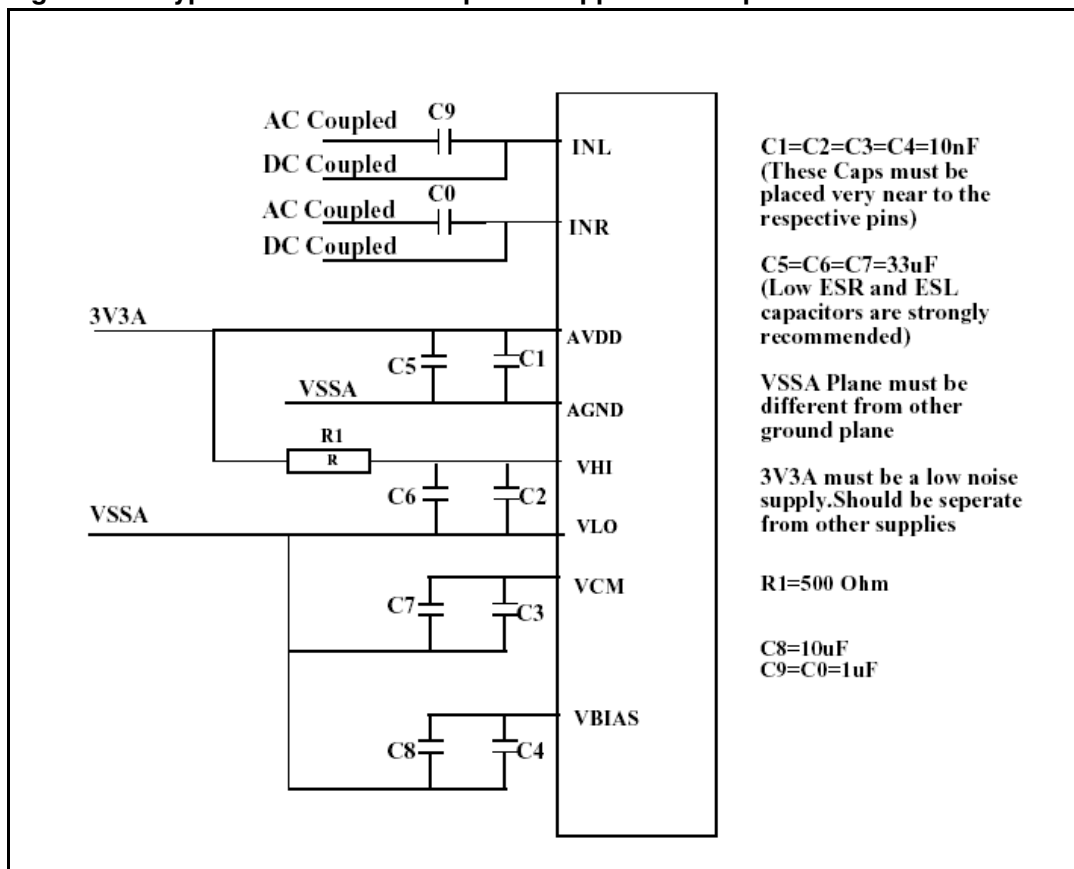

### 10.2.1 Configuration example

This is an example of the register setup for the ADC inputs. It is assumed that every peripheral is already configured and working correctly.

There are other configuration examples to help you get started please refer to other chapters and also to [Chapter 14: Register description on page 77](#) in order to get all the necessary and complementary details.

[Table 27](#) shows the register settings for selecting INL2 and INR2 as input source for SRC and SAI\_out1 and using the PGA with a 12-dB gain.

Table 27. Example register settings for ADC

Register	Value	Description
ADCCFG1	0x40	Selecting INL2 and INR2 as sources
ADCCFG0	0x52	PGA Gain = +12 dB, PGA enabled, ADC clock on
P2SDATA	0x40	ADC Data routed also to the SAI_out

# 11 Serial audio interface

The data on pins SDATAI, SDATAO, LRCLKI and LRCLKO are always synchronous with the bit clock. The data on these pins changes with the BICLK active (or clocking) edge.

The BICLK strobe edge latches the data SDATAI, SDATAO, LRCLKI, LRCLKO; thus this data should be stable near the BICLK strobe edges. The slave device uses the strobe edges to latch the serial data internally.

The active and strobe edges can be selected to be the rising edge or the falling edge by appropriately programming register bits [SAI\\_IN1\\_CFG0\[7\]](#), [SAI\\_OUT\\_CFG0\[7\]](#) and [SAI\\_IN2\\_CFG0\[7\]](#).

The serial-to-parallel interface and the parallel-to-serial interface can have different sampling rates. [Figure 41](#) shows a typical setup.

**Figure 41. SAI typical sampling rates**

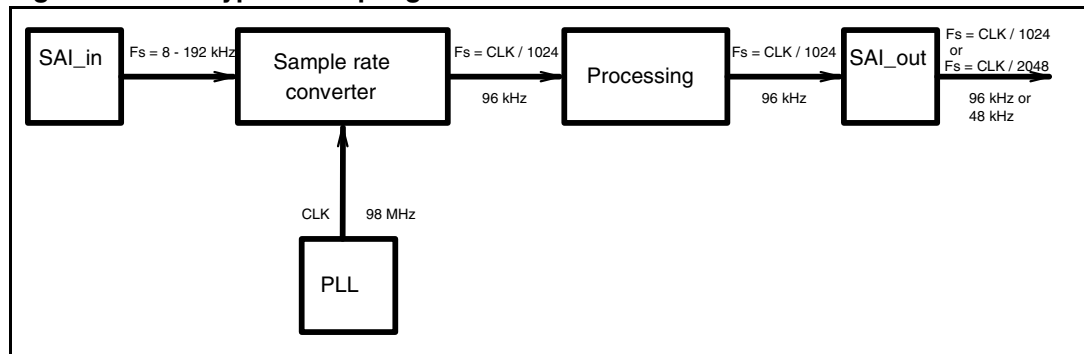

## 11.1 Master mode

In this mode BICLK/BICLKO and LRCLKI/LRCLKO are configured as outputs and are generated by the core.

**Figure 42. Timing diagram for master mode**

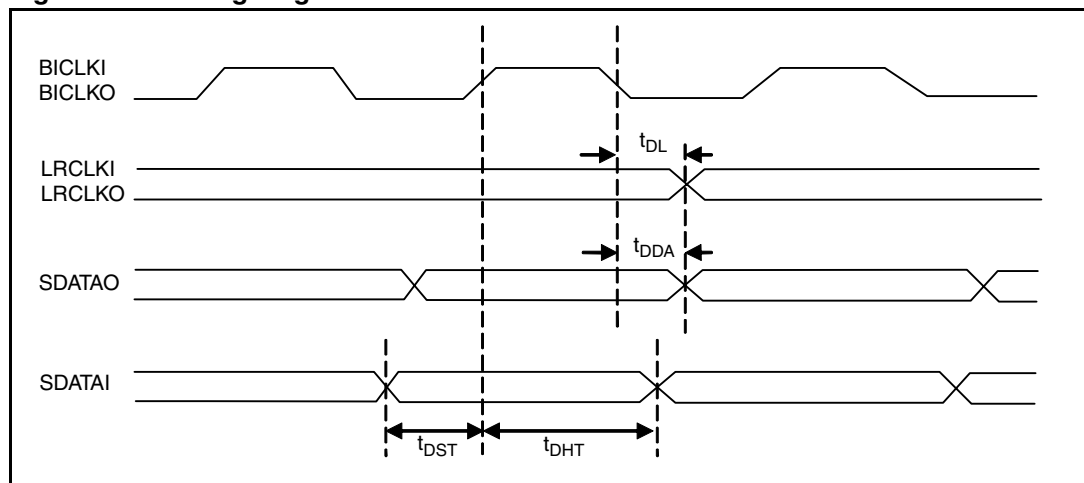

**Table 28. Timing parameters for master mode**

Symbol	Parameter	Min	Typ	Max	Unit
$t_{DL}$	LRCLKI/LRCLKO propagation delay from BICLK active edge	0	-	10	ns
$t_{DDA}$	SDATAI propagation delay from BICLK/O active edge	0	-	15	ns
$t_{DST}$	SDATAO setup time to BICLK/O strobing edge	10	-	-	ns
$t_{DHT}$	SDATAO hold time from BICLK/O strobing edge	10	-	-	ns

## 11.2 Slave mode

In this mode BICLK/O and LRCLKI/O are configured as inputs and supplied by the external peripheral.

**Figure 43. Timing diagram for slave mode**

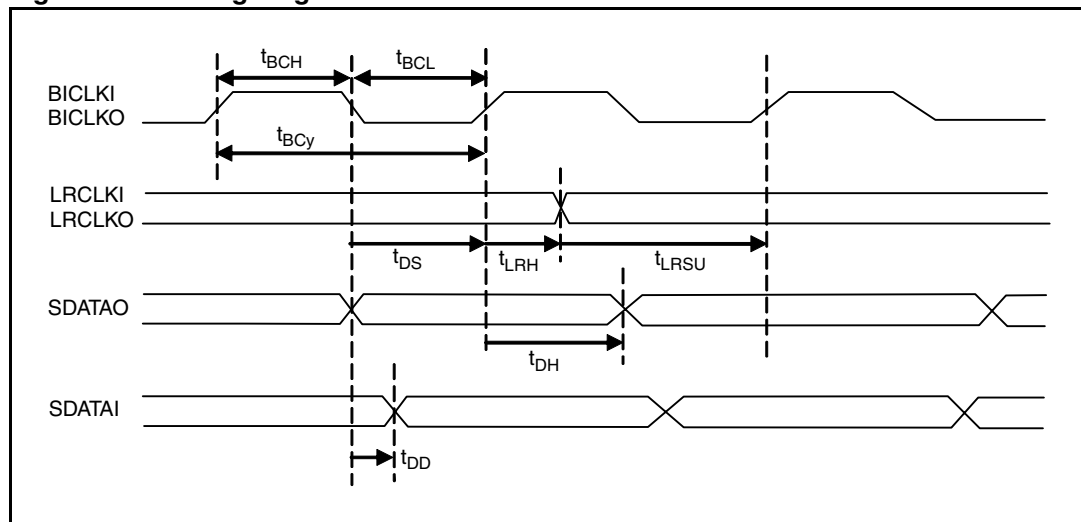

**Table 29. Timing parameters for slave mode**

Symbol	Parameter	Min	Typ	Max	Unit
$t_{BCy}$	BICLK cycle time	50	-	-	ns
$t_{BCH}$	BICLK pulse width high	20	-	-	ns
$t_{BCL}$	BICLK pulse width low	20	-	-	ns
$t_{LRSU}$	LRCLKI/LRCLKO setup time to BICLK strobing edge	10	-	-	ns
$t_{LRH}$	LRCLKI/LRCLKO hold time to BICLK strobing edge	10	-	-	ns
$t_{DS}$	SDATAO setup time to BICLK strobing edge	10	-	-	ns
$t_{DH}$	SDATAO hold time to BICLK strobing edge	10	-	-	ns
$t_{DD}$	SDATAI propagation delay from BICLK active edge	0	-	10	ns

### 11.3 Serial formats

Different audio formats are supported in both master and slave modes. Clock and data configurations can be customized to match most of the serial audio protocols available on the market.

Data length can be customized for 8, 16, 24 or 32 bits.

#### 11.3.1 Right justified

Figure 44. Right justified serial format

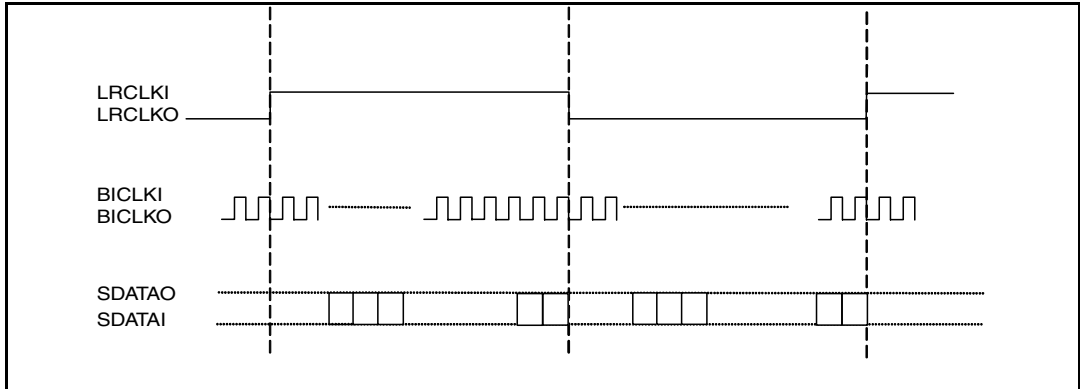

#### 11.3.2 Left justified

Figure 45. Left justified serial format

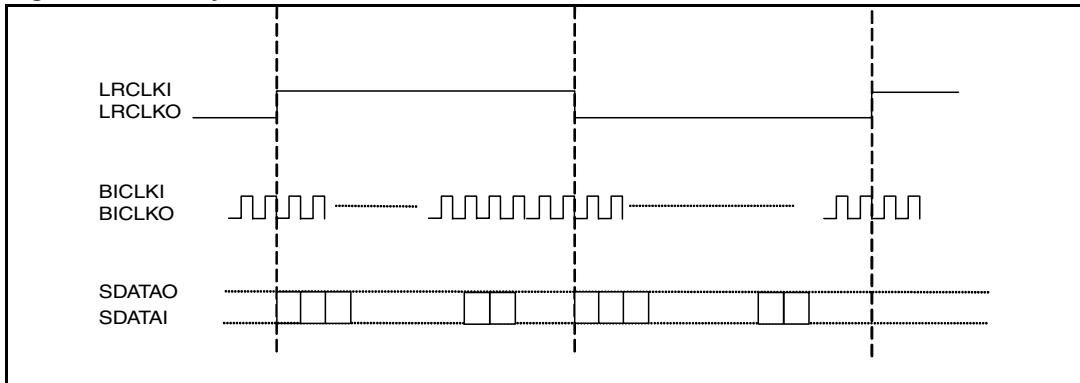

### 11.3.3 DSP

Figure 46. DSP serial format

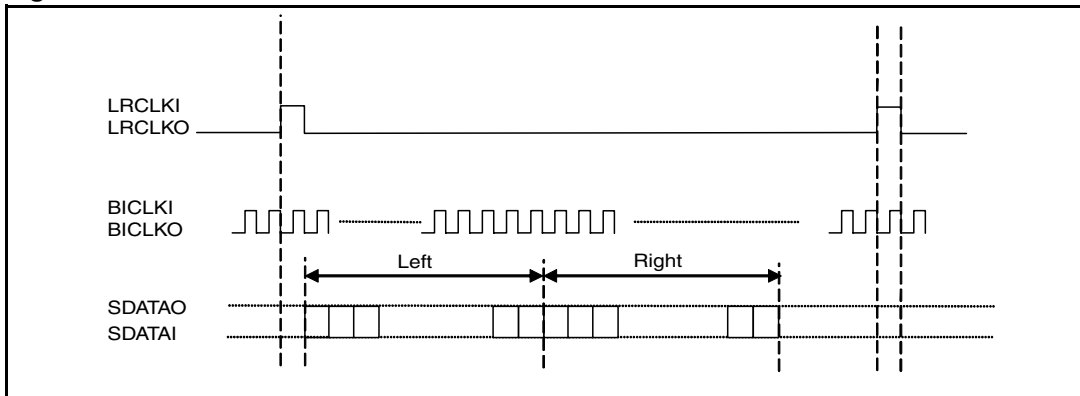

### 11.3.4 I<sup>2</sup>S

Figure 47. I<sup>2</sup>S serial format

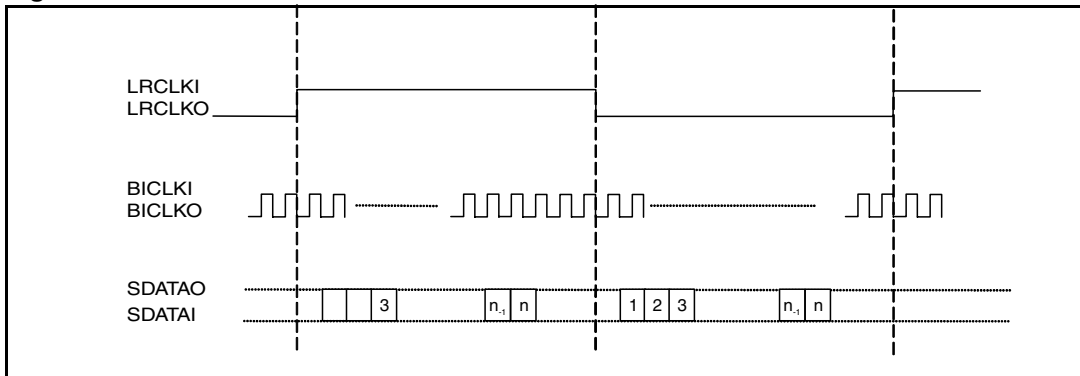

### 11.3.5 PCM/IF (non-delayed mode)

- MSB first
- 16-bit data.

Figure 48. PCM (non-delayed) serial format

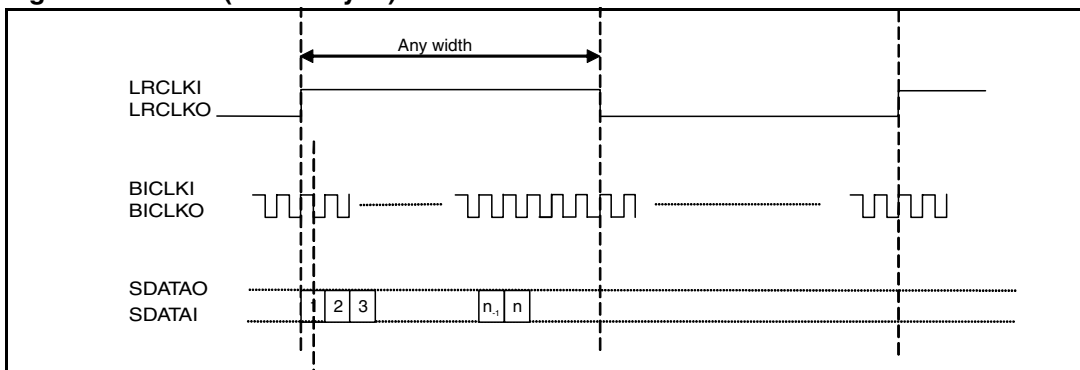

### 11.3.6 PCM/IF (delayed mode)

- MSB first
- 16-bit data.

**Figure 49. PCM (delayed) serial format**

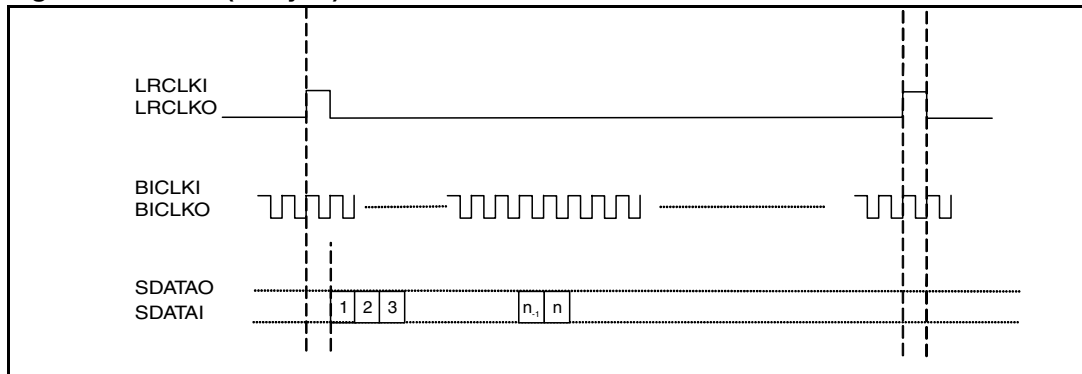

### 11.4 Invalid detection

STA321 has an invalid input detection feature that can detect an invalid serial interface bit clock or frame clock and then mute the processing channels to avoid any speaker or headphone damage and, moreover, to avoid loud audible transients which may be discomforting to the listener. The control is active only for the SAI input. The configuration programmed in bits 0, 1 and 2 of register *FFXCFG0* on page 82 is applicable to both SAI1 and SAI2 whilst the checks are independent for each interface. The mute on the processing channel is asserted depending on the input interface mapping.

*Figure 50* shows the invalid detection schematic. Here, two different checks are available. The first one is enabled by register bit *FFXCFG0.BAD\_CKS\_M* and evaluates the ratio of BICLK and LRCLK. The resulting number must be the same as that written in bits S2Pn\_BOS (for example,  $32 * f_s$  or  $64 * f_s$ ) in registers *SAI\_IN1\_CFG1* on page 123 and *SAI\_IN2\_CFG1*, otherwise the channels are muted.

The second check is enabled by register bit *FFXCFG0.MIS\_BICK\_M* and is related to the presence of BICLK. Basically, a 8-bit watchdog counter decrements, starting from 0xFF, with each edge of *clk\_proc*. The counter is reset to 0xFF at each BICLK edge; so, if the watchdog counter ever reaches 0x00, a missing bit clock error is signalled and the mute command is issued.

**Figure 50. Invalid input detection schematic**

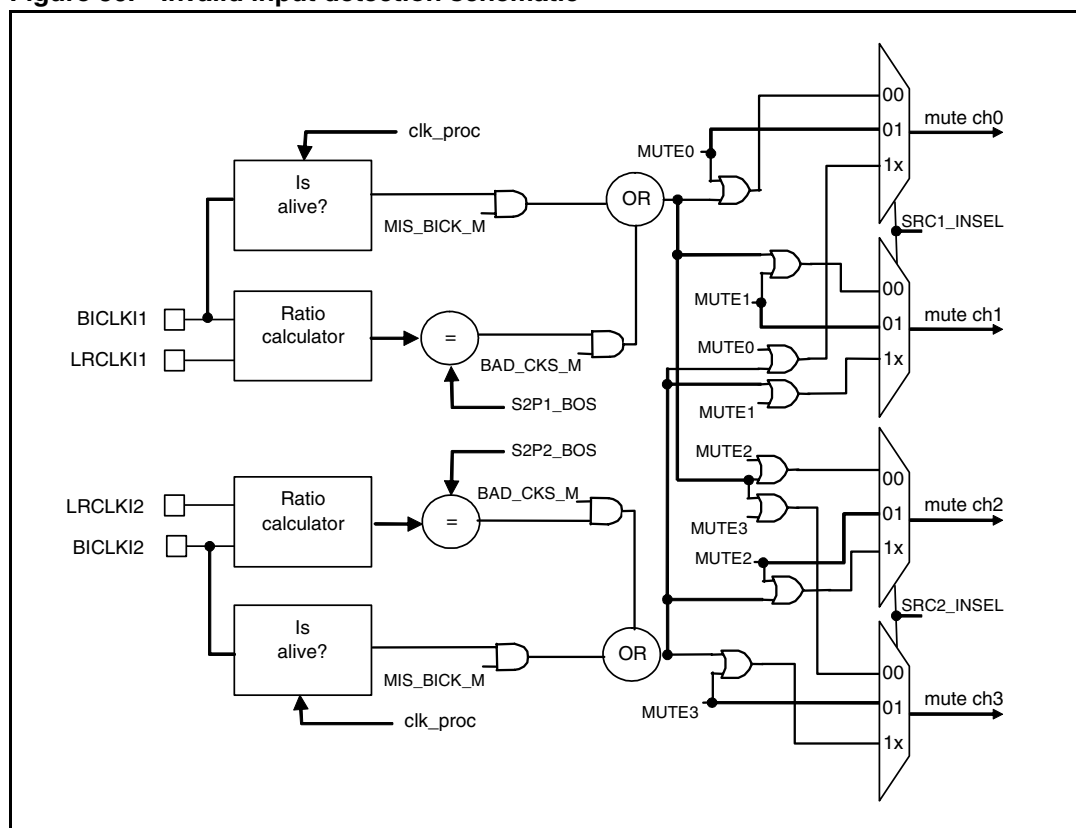

## 12 Headphone detection

The headphone detector circuit, shown in [Figure 51](#), is made with two schmitt-trigger comparators (with different thresholds) which sense the value of the HPDECT input voltage and modifies the HP\_DET1 or the HP\_DET2 level as given in [Table 30](#) and [Table 31](#) below. The comparators are enabled or disabled with bits E\_HP1 and E\_HP2 in register [HPDET2 on page 138](#)

**Table 30. Headphone 1 detector**

E_HP1 (register HPDET2)	HP-jack status	HP_DET voltage	HP_DET1	Status register bit HPDST.HP_DET_FILT
1	Unplugged	Low	0	-
1	Plugged	High	1	-
0	X	X	1	-

**Table 31. Headphone 2 detector**

E_HP2 (register HPDET2)	HP-jack status	HP_DET voltage	HP_DET2	Status register bit HPDST.HP_DET_FILT
1	Unplugged	Low	1	-
1	Plugged	High	0	-
0	X	X	1	-

The comparator output status is provided via bits 1 and 0 of register [HPDET2 on page 138](#). One of the comparator outputs is then selected with register bit [HPDET1.HPD\\_SEL](#), and that signal is passed through a digital debouncing filter and supplied to the FFX modulator. The PWM outputs are then modified depending on the settings of register bits [HPDST.HP\\_DET\\_FILT](#) and [HPDET1.HPD\\_ACT\\_MODE](#).



## 12.2 Configuration example

This is an example of the register setup for headphones detection. It is assumed that every peripheral is already configured and working correctly.

There are other configuration examples to help you get started please refer to other chapters and also to [Chapter 14: Register description on page 77](#) in order to get all the necessary and complementary details.

[Table 32](#) and [Table 33](#) below give a possible setup for the headphones detection configurations shown in [Figure 51](#) and [Figure 52](#), respectively.

**Table 32. Headphone detection configuration sequence for binary SE**

Register	Value	Description
<a href="#">MISC on page 135</a>	0x21	Enable core clock
<a href="#">PLL on page 136</a>	0x00	Use PLL clock
User FFX and CMOS bridge configuration		
<a href="#">HPDET2 on page 138</a>	0x80	Disable the HP_DET pull-up
<a href="#">HPDET1 on page 137</a>	0x57	Use HP1 for hpdet filter; polarity = high; action = mute; mod = binary SE; average time 170 ms.
<a href="#">HPDET2 on page 138</a>	0x80	Select E_HP1 comparator
<a href="#">FFXCFG1 on page 81</a>	0x00	Remove the tristate from the bridges

**Table 33. Headphone detection configuration sequence for binary headphone**

Register	Value	Description
<a href="#">MISC on page 135</a>	0x21	Enable core clock
<a href="#">PLL on page 136</a>	0x00	Use PLL clock
User FFX and CMOS bridge configuration		
<a href="#">HPDET2 on page 138</a>	0x80	Disable the HP_DET pull-up
<a href="#">HPDET1 on page 137</a>	0x5F	Use HP1 for hpdet filter; polarity = high; action = mute; mod = binary HP; average time 170 ms.
<a href="#">HPDET2 on page 138</a>	0x80	Select E_HP1 comparator
<a href="#">FFXCFG1 on page 81</a>	0x00	Remove the tristate from the bridges

*Note:* The pullup on HPDET pad must always be disabled before using the HPDET function.

*Note:* Comparator 1 and comparator 2 cannot be enabled simultaneously.

## 13 I<sup>2</sup>C interface

### 13.1 Communication protocol

#### 13.1.1 Data transition and change

Data changes on the SDA line must only occur when the SCL clock is low. SDA transition while the clock is high is used to identify a START or STOP condition.

#### 13.1.2 Start condition

START is identified by a high to low transition of the SDA bus while the clock signal, SCL, is stable in the high state. A START condition must precede any command for data transfer.

#### 13.1.3 Stop condition

STOP is identified by a low to high transition on the SDA bus while the clock signal, SCL, is stable in the high state. A STOP condition terminates communication between STA321 and the bus master.

#### 13.1.4 Data input

During the data input the STA321 samples the SDA signal on the rising edge of clock SCL. For correct device operation the SDA signal must be stable during the rising edge of the clock and the data can change only when the SCL line is low.

#### 13.1.5 Device addressing

To start communication between the master and the STA321, the master initiates with a start condition. Following this, the master sends 8 bits (MSB first) on the SDA line which corresponds to the device select address and read or write mode.

The 7 MSBs are the device address identifiers, corresponding to the I<sup>2</sup>C bus definition. In the STA321 the I<sup>2</sup>C interface has the device address 0x30.

After a START condition the STA321 identifies the device address and if a match is found, acknowledges the identification on SDA bus during the 9th bit time. The byte following the device identification byte is the internal space address.

#### 13.1.6 Write operation

Following the START condition the master sends a device select code with the RW bit set to 0. After the STA321 acknowledge, the master sends the byte of internal address. On receiving the internal byte address the STA321 responds with acknowledge.

##### Byte write

In the byte write mode the master sends one data byte, this is acknowledged by the STA321. The master then terminates the transfer by generating a STOP condition.

### Multi-byte write

The multi-byte write mode starts from any internal address. The master generates a STOP condition to terminate the transfer.

## 13.1.7 Read operation

### Current address byte read

Following the START condition the master sends a device select code with the RW bit set to 1. The STA321 acknowledges and then responds by sending one byte of data. The master then terminates the transfer by generating a STOP condition.

### Current address multi-byte read

The multi-byte read mode start from any internal address. Data bytes are read from sequential addresses within the STA321. The master acknowledges each data byte read and then generates a STOP condition to terminate the transfer.

### Random address byte read

Following the START condition the master sends a device select code with the RW bit set to 0. The STA321 acknowledges and then the master writes the internal address byte. After receiving, the internal byte address the STA321 again responds with an acknowledge. The master then initiates another START condition and sends the device select code with the RW bit set to 1. The STA321 acknowledges this and then responds by sending one byte of data. The master then terminates the transfer by generating a STOP condition.

### Random address multi-byte read

The multi-byte read modes start from any internal address. Data bytes are read from sequential addresses within the STA321. The master acknowledges each data byte read and then generates a STOP condition to terminate the transfer.

Figure 53. I<sup>2</sup>C write operations

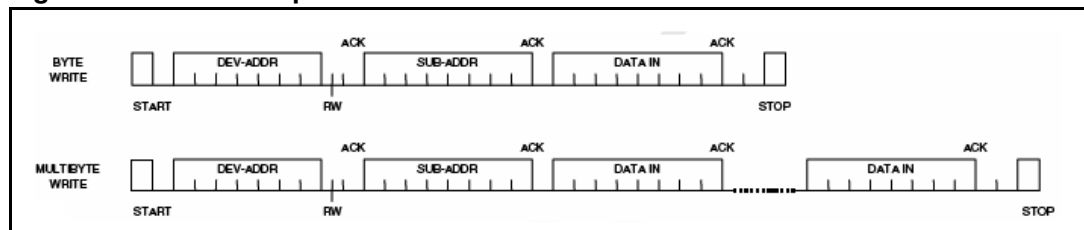
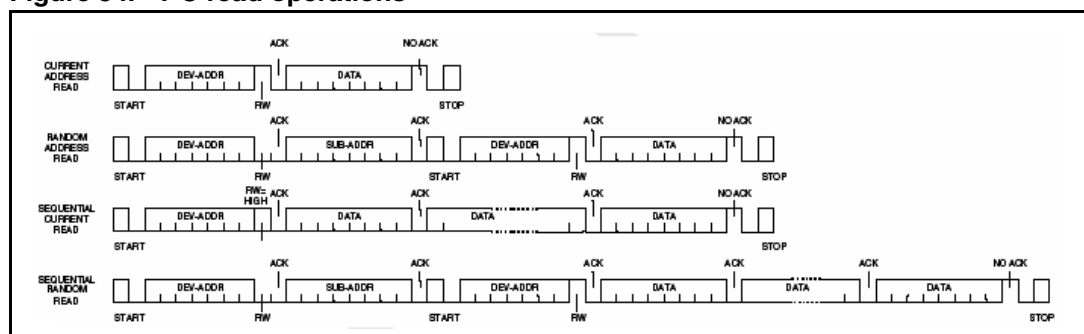

Figure 54. I<sup>2</sup>C read operations



# 14 Register description

**Table 34. Register summary**

Register	Addr	7	6	5	4	3	2	1	0	
FFXCFG1	0x00	EA_STBY	CB_STBY	EA_TRIST	FFX_ULCK_PLL		CB_TRIST2	CB_TRIST1	CB_TRIST0	
FFXCFG0	0x01	MUTE3	MUTE2	MUTE1	MUTE0	PWM00_3A	BAD_IN_M	BAD_CKS_M	MIS_BICK_M	
FFXCFG2	0x02	RESET_NOISH	PWM_FREQ	NS_ORD[1:0]		EA_TSFT_ON	CB_TSFT_ON	EA_PFDIG	CB_PFDIG	
PWMMAP1	0x03	CB1_MAP[2:0]			CB2_MAP[2:0]			CB3_MAP[2:1]		
PWMMAP2	0x04	CB3_MAP[0]	PWM00_MAP[2:0]			EA1A_MAP[2:0]			EA1B_MAP[2]	
PWMMAP3	0x05	EA1B_MAP[1:0]		EA2A_MAP[2:0]			EA2B_MAP[2:0]			
EATTF0	0x06	EATTF[7:0]								
EATTF1	0x07	EATTF[7:0]								
EATTP0	0x08	EATTP[15:8]								
EATTP1	0x09	EATTP[7:0]								
CBTTF0	0x0A	CBTTF[15:8]								
CBTTF1	0x0B	CBTTF[7:0]								
CBTTP0	0x0C	CBTTP[15:8]								
CBTTP1	0x0D	CBTTP[7:0]								
FFXST	0x0E	EA_MPWM	CB_MPWM	EARMP_ST[1:0]		CBRMP_ST[1:0]		EABINSS_AC	CBBINSS_AC	
POWST	0x0F	Reserved				EA_TW	EA_PD	EA_FT	EA_TS	
POWST1	0x10	Reserved	CB_PD	CB_FT[2:0]			CB_TS[2:0]			
PWMO1CFG0	0x11	AZPLS_1	TERNARY_1	HALFB_1	MP_ZERO_1	MIN_PLS_1[3:0]				
PWMO1CFG1	0x12	PM_1A[1:0]			PS_1A[5:0]					
PWMO1CFG2	0x13	PM_1B[1:0]			PS_1B[5:0]					
PWMO2CFG0	0x14	AZPLS_2	TERNARY_2	HALFB_2	MP_ZERO_2	MIN_PLS_2[3:0]				
PWMO2CFG1	0x15	PM_2A[1:0]			PS_2A[5:0]					
PWMO2CFG2	0x16	PM_2B[1:0]			PS_2B[5:0]					
PWMO3CFG0	0x17	AZPLS_3	TERNARY_3	HALFB_3	MP_ZERO_3	MIN_PLS_3[3:0]				
PWMO3CFG1	0x18	PM_3A[1:0]			PS_3A[5:0]					
PWMO3CFG2	0x19	PM_3B[1:0]			PS_3B[5:0]					
PWMO4CFG0	0x1A	AZPLS_4	TERNARY_4	HALFB_4	MP_ZERO_4	MIN_PLS_4[3:0]				
PWMO4CFG1	0x1B	PM_4A[1:0]			PS_4A[5:0]					
PWMO4CFG2	0x1C	PM_4B[1:0]			PS_4B[5:0]					
CB_PFRAMP1	0x20	CBRMP_MP[5:0]						Reserved		
CB_PFRAMP2	0x21	CBRMPINI[15:8]								
CB_PFRAMP3	0x22	CBRMPINI[7:0]								
CB_PFRAMP4	0x23	CBTIM_RMP[3:0]				Reserved				
CB_PFRAMP5	0x24	CBRMPPTH[15:8]								
CB_PFRAMP6	0x25	CBRMPPTH[7:0]								
EA_PFRAMP1	0x26	EARMP_MP[5:0]						Reserved		
EA_PFRAMP2	0x27	EARMPINI[15:8]								

**Table 34. Register summary (continued)**

Register	Addr	7	6	5	4	3	2	1	0	
EA_PFRAMP3	0x28	EARMPINI[7:0]								
EA_PFRAMP4	0x29	EATIM_RMP[3:0]				Reserved				
EA_PFRAMP5	0x2A	EARMPTH[15:8]								
EA_PFRAMP6	0x2B	EARMPTH[7:0]								
SRC1STATE	0x30	SRC1_BYP[1:0]	SRC_1_LOCK		SRC1_FISFO[4:0]					
SRC2STATE	0x31	SRC1_BYP[1:0]	SRC_1_LOCK		SRC1_FISFO[4:0]					
I2CB0_TOP	0x51	I2CB0[23:16]								
I2CB0_MID	0x52	I2CB0[15:8]								
I2CB0_BOT	0x53	I2CB0[7:0]								
I2CB1_TOP	0x54	I2CB1[23:16]								
I2CB1_MID	0x55	I2CB1[15:8]								
I2CB1_BOT	0x56	I2CB1[7:0]								
I2CB2_TOP	0x57	I2CB2[23:16]								
I2CB2_MID	0x58	I2CB2[15:8]								
I2CB2_BOT	0x59	I2CB2[7:0]								
I2CA1_TOP	0x5A	I2CA1[23:16]								
I2CA1_MID	0x5B	I2CA1[15:8]								
I2CA1_BOT	0x5C	I2CA1[7:0]								
I2CA2_TOP	0x5D	I2CA2[23:16]								
I2CA2_MID	0x5E	I2CA2[15:8]								
I2CA2_BOT	0x5F	I2CA2[7:0]								
PROCCTRL	0x60	Reserved				RA	Reserved	WA	W1	
START_ADD2	0x61	Reserved								I2CSTART_A8
START_ADD	0x62	I2CSTART_A7_A0								
ROM_REMAP	0x6F	Reserved	ENAB_PRE3	ENAB_PRE2	ENAB_PRE1	ENAB_PRE0	ENAB_POST	ENAB_PRMIX	ENAB_DELAY	
BYP_EN_CH0	0x70	Reserved								
EFFS_EN_CH0	0x71	Reserved						EROM09	EROM08	
BYP_EN_CH1	0x72	Reserved								
EFFS_EN_CH1	0x73	Reserved						EROM19	Reserved	
BYP_EN_CH2	0x74	Reserved								
EFFS_EN_CH2	0x75	Reserved						EROM29	EROM28	
BYP_EN_CH3	0x76	Reserved								
EFFS_EN_CH3	0x77	Reserved						EROM39	Reserved	
BASS_SEL0_R	0x78	Reserved		BASS_EN0	BASS_SEL0					
BASS_SEL1_R	0x79	Reserved		BASS_EN1	BASS_SEL1					
BASS_SEL2_R	0x7A	Reserved		BASS_EN2	BASS_SEL2					
BASS_SEL3_R	0x7B	Reserved		BASS_EN3	BASS_SEL3					
TREB_SEL0_R	0x7C	Reserved		TREB_EN0	TREB_SEL0					
TREB_SEL1_R	0x7D	Reserved		TREB_EN1	TREB_SEL1					
TREB_SEL2_R	0x7E	Reserved		TREB_EN2	TREB_SEL2					

**Table 34. Register summary (continued)**

Register	Addr	7	6	5	4	3	2	1	0	
TREB_SEL3_R	0x7F	Reserved		TREB_EN3	TREB_SEL3					
SATCH0CFG1	0x90	SAT_EQ	SAT_CH0[22:16]							
SATCH0CFG2	0x91	SAT_CH0[15:8]								
SATCH0CFG3	0x92	SAT_CH0[7:0]								
SATCH1CFG1	0x93	Reserved	SAT_CH1[22:16]							
SATCH1CFG2	0x94	SAT_CH1[15:8]								
SATCH1CFG3	0x95	SAT_CH1[7:0]								
SATCH2CFG1	0x96	Reserved	SAT_CH2[22:16]							
SATCH2CFG2	0x97	SAT_CH2[15:8]								
SATCH2CFG3	0x98	SAT_CH2[7:0]								
SATCH3CFG1	0x99	Reserved	SAT_CH3[22:16]							
SATCH3CFG2	0x9A	SAT_CH3[15:8]								
SATCH3CFG3	0x9B	SAT_CH3[7:0]								
VOLCFG	0xA0	SVOL_ON3	SVOL_ON2	SVOL_ON1	SVOL_ON0	TIM_SVOL				
MVOL	0xA1	MVOL								
VOLCH0	0xA2	CVOL0								
VOLCH1	0xA3	CVOL1								
VOLCH2	0xA4	CVOL2								
VOLCH3	0xA5	CVOL3								
SAI_IN1_CFG0	0xB0	S2P1_B_STR	S2P1_LR_L	Reserved	S2P1_MSB	S2P1_DFM			S2P1_MMD	
SAI_IN1_CFG1	0xB1	S2P1_DLEN		S2P1_BOS		S2P1_MAP_L		S2P1_MAP_R		
SAI_OUT_CFG0	0xB2	P2S_B_STR	P2S_LR_L	SDATAO_ACT	P2S_MSB	P2S_DFM			P2S_MMD	
SAI_OUT_CFG1	0xB3	P2S_DLEN		P2S_BOS		P2S_MAP_L		P2S_MAP_R		
SAI_IN2_CFG0	0xB4	S2P2_B_STR	S2P2_LR_L	Reserved	S2P2_MSB	S2P2_DFM			S2P2_MMD	
SAI_IN2_CFG1	0xB5	S2P2_DLEN		S2P2_BOS		S2P2_MAP_L		S2P2_MAP_R		
AUIFSHARE	0xB6	Reserved							SHARE_BILR	
SRCINSEL	0xB7	SRC1_INSEL		SRC2_INSEL		MUTE_SRCU	Reserved			
P2SDATA	0xB8	Reserved	P2S_HFS	P2S1_DSEL			P2S2_DSEL			
PLLCFG0	0xC0	PLL_DPROG	PLL_FR_CTRL	PLL_DDIS		PLL_IDF				
PLLCFG1	0xC1	PLL_FRAC[15:8]								
PLLCFG2	0xC2	PLL_FRAC[7:0]								
PLLCFG3	0xC3	PLL_STRB	PLL_STRBBYP	PLL_NDIV						
PLLPFE	0xC4	PLL_BYP_UNL	BICKL2PLL	PLL_PWDN	PLL_NOPDDIV	Reserved				
PLLST	0xC5	PLL_UNLOCK	PLL_PWD_ST	PLL_BYP_ST	Reserved					
ADCCFG0	0xC6	ADC_PGA			ADC_INSEL	ADC_STBY	ADC_BYPCAL	CLK_ADC_ON	Reserved	
CKOCFG	0xC7	CLKOUT_DIS	CLKOUT_SEL		CLK_FFX_ON	CLK_SRC_ON	CLK_PROC_ON	EAPWM_DIS	PWM00ACT	
MISC	0xC8	OSC_DIS	S2P_FS_RNG			ADC_FS_RNG		P2P_IN_ADC	CLKCORE_ON	

**Table 34. Register summary (continued)**

Register	Addr	7	6	5	4	3	2	1	0
PLL_B	0xC9	PLL_BYP	Reserved	ADC_CLKSEL	Reserved	P2S1_CLKSEL	Reserved	P2S2_CLKSEL	Reserved
HPDET1	0xCA	HPD_SEL	HPD_POL	HPD_ACT_MODE		HPD_HPMOD	HPD_TIM_F		
HPDET2	0xCB	E_HP2	E_HP1	TUD_EN	Reserved			E_HPDET1	E_HPDET2
HPDST	0xCC	HPD_DET_FILTER	Reserved						
STBY_MODES	0xCD	PAD_PULDIS	Reserved					CMP_EN_N	DC_STBY_EN_N
ADCCFG1	0xCE	ADC_ANA_SEL		Reserved					
PFEFAULT	0xCF	Reserved			PFE1	PFE2	PFE3	RESET_EA_FT	RESET_CB_FT
BISTRUN0	0xD0	SF1_BRUN	SF2_BRUN	SS1_BRUN	SS2_BRUN	CF_BRUN	PR_BRUN	CF_ROM_BRUN	Reserved
BISTRUN1	0xD1	OS_BRUN	DB_BRUN	Reserved					
BISTST0	0xD2	SF1_BEND	SF1_BBAD	SF1_BFAIL	SF2_BEND	SF2_BBAD	SF2_BFAIL	SS1_BEND	SS1_BBAD
BISTST1	0xD3	SS1_BFAIL	SS2_BEND	SS2_BBAD	SS2_BFAIL	CF_BEND	CF_BBAD	CF_BFAIL	PR_BEND
BISTST2	0xD4	PR_BBAD	PR_BFAIL	OS_BEND	OS_BBAD	OS_BFAIL	DB_BEND	DB_BBAD	DB_BFAIL
BISTST3	0xD5	CF_ROM_BEND	Reserved						
ROMSIGN0	0xD6	CF_ROMS[7:0]							
ROMSIGN1	0xD7	CF_ROMS[15:8]							
ROMSIGN2	0xD8	CF_ROMS[23:16]							
DEBUG0	0xD9	DBGCKO_ON	DBGCKO_VAL						
PADST0	0xF0	PAD_RSTN	Reserved	PAD_SCL	PAD_SDA	PAD_I2CDIS	Reserved		PAD_STBY
PADST1	0xF1	PAD_MUTE	PAD_BICLKI	PAD_LRCLKI	PAD_SDATAI	PAD_BICLKO	PAD_LRCLKO	Reserved	

**FFXCFG1**

7	6	5	4	3	2	1	0
EA_STBY	CB_STBY	EA_TRIST	FFX_ULCK_PLL		CB_TRIST2	CB_TRIST1	CB_TRIST0

**Address:** 0x00**Type:** RW**Reset:** 0xD0**Description:**

- [7] EA\_STBY
  - 0: the external bridge is active
  - 1: the external bridge is in standby mode
- [6] CB\_STBY
  - 0: the bridge is active
  - 1: the bridge is in standby mode
- [5] EA\_TRIST
  - 0: normal behaviour
  - 1: the external bridge is put in 3-state mode
- [4:3] FFX\_ULCK\_PLL: behavior of the FFX modulator in the event of the PLL losing lock:
  - 00: do nothing
  - 01: FFX hard mute (equivalent to using pin MUTE)
  - 10: FFX standby
  - 11: FFX hard mute and noise-shaper reset
- [2] CB\_TRIST2
  - 0: the bridge is active
  - 1: force CMOS bridge OUT3 to 3-state
- [1] CB\_TRIST1
  - 0: the bridge is active
  - 1: force CMOS bridge OUT2 to 3-state
- [0] CB\_TRIST0
  - 0: normal behaviour
  - 1: force CMOS bridge OUT1 to 3-state

**FFXCFG0**

7	6	5	4	3	2	1	0
MUTE3	MUTE2	MUTE1	MUTE0	PWM00_3A	BAD_IN_M	BAD_CKS_M	MIS_BICK_M

**Address:** 0x01**Type:** RW**Reset:** 0x07**Description:**

- [7] MUTE3
  - 0: normal behaviour
  - 1: force the mute in the channel 3
- [6] MUTE2
  - 0: normal behaviour
  - 1: force the mute in the channel 2
- [5] MUTE1
  - 0: normal behaviour
  - 1: force the mute in the channel 1
- [4] MUTE0
  - 0: normal behaviour
  - 1: force the mute in the channel 0
- [3] PWM00\_3A
  - 0: output PWM00 is driven by FFX (default)
  - 1: output PWM00 comes from FFX output PWM3A and is not sensitive to bridge power-down or 3-state states
- [2] BAD\_IN\_M
  - Depending on the bit 0 and bit 1 settings
  - 0: mute with a ramp
  - 1: mute instantaneously
- [1] BAD\_CKS\_M
  - 0: FFX not muted
  - 1: FFX muted if bick and lrlk do not meet the specification
- [0] MIS\_BICK\_M
  - 0: FFX not muted
  - 1: FFX will be muted if bick is missing

**FFXCFG2**

7	6	5	4	3	2	1	0
RESET_NOISH	PWM_FREQ	NS_ORD[1:0]		EA_TSFT_ON	CB_TSFT_ON	EA_PFDIG	CB_PFDIG

**Address:** 0x02

**Type:** RW

**Reset:** 0x2D

**Description:**

[7] **RESET\_NOISH**

1: a reset is forced to the noise-shaper block

[6] **PWM\_FREQ**

0: 4 f<sub>S</sub> (4\*96 kHz = 384 kHz)

1: 8 f<sub>S</sub> (8\*96 kHz = 768 kHz)

[5:4] **NS\_ORD[1:0]**

Noise shape order

00: 3rd. order

01: 4th. order

10: 5th. order

[3] **EA\_TSFT\_ON**

1: if there is a fault on the external bridge, it will be put in 3-state

[2] **CB\_TSFT\_ON**

1: if there is a fault on the CMOS bridge, it will be put in 3-state

[1] **EA\_PFDIG**

1: enable the pop-free ramp of EA

[0] **CB\_PFDIG**

1: enable the pop-free ramp of CB

*Note: Particular care must be taken when bits NS\_ORD and PWM\_FREQ are changed. To avoid any audible artifacts, these bits must be modified only with the following procedure:*

1. Mute STA321 processing.
2. Change PWM\_FREQ and/or NS\_ORD and set RESET\_NOISH = 1.
3. Configure RESET\_NOISH = 0.
4. Unmute STA321 processing.

**PWMMAP1** **Processing to PWM out mapping**

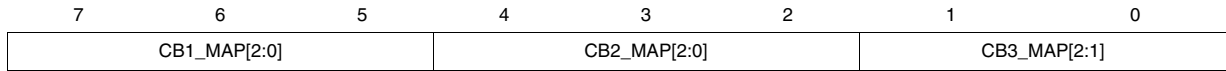

**Address:** 0x03

**Type:** RW

**Reset:** 0x08

**Description:**

- [7:5] CB1\_MAP[2:0]  
 CB\_PWM\_1 channel mapping:
 

000: Ch0-A	001: Ch0-B
010: Ch1-A	011: Ch1-B
100: Ch2-A	101: Ch2-B
110: Ch3-A	111: Ch3-B
  
- [4:2] CB2\_MAP[2:0]  
 CB\_PWM\_2 channel mapping
 

000: Ch0-A	001: Ch0-B
010: Ch1-A	011: Ch1-B
100: Ch2-A	101: Ch2-B
110: Ch3-A	111: Ch3-B
  
- [1:0] CB3\_MAP[2:1]  
 CB\_PWM\_3 channel mapping (for bit 0 see register [PWMMAP2](#)):
 

000: Ch0-A	001: Ch0-B
010: Ch1-A	011: Ch1-B
100: Ch2-A	101: Ch2-B
110: Ch3-A	111: Ch3-B

**PWMMAP2**

7	6	5	4	3	2	1	0
CB3_MAP[0]	PWM00_MAP[2:0]			EA1A_MAP[2:0]			EA1B_MAP[2]

**Address:** 0x04**Type:** RW**Reset:** 0xB9**Description:****[7] CB3\_MAP[0]**CB\_PWM\_3 channel mapping (for bits 1 and 2 see register [PWMMAP1](#))**[6:4] PWM00\_MAP[2:0]**

PWM00 channel mapping:

000: Ch0-A	001: Ch0-B
010: Ch1-A	011: Ch1-B
100: Ch2-A	101: Ch2-B
110: Ch3-A	111: Ch3-B

**[3:1] EA1A\_MAP[2:0]**

EA\_PWM\_1A channel mapping:

000: Ch0-A	001: Ch0-B
010: Ch1-A	011: Ch1-B
100: Ch2-A	101: Ch2-B
110: Ch3-A	111: Ch3-B

**[0] EA1B\_MAP[2]**EA\_PWM\_1B channel mapping (for bits 1 and 0 see register [PWMMAP3](#))

000: Ch0-A	001: Ch0-B
010: Ch1-A	011: Ch1-B
100: Ch2-A	101: Ch2-B
110: Ch3-A	111: Ch3-B

**PWMMAP3**

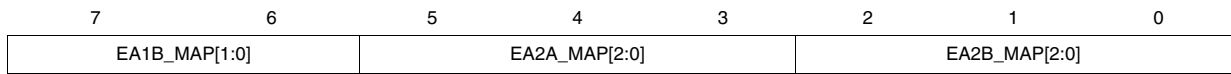

**Address:** 0x05

**Type:** RW

**Reset:** 0x77

**Description:**

- [7:6] **EA1B\_MAP[1:0]**  
EA\_PWM\_1B channel mapping (for bit 2 see register [PWMMAP2](#))
- [5:3] **EA2A\_MAP[2:0]**  
EA\_PWM\_2A channel mapping:
 

000: Ch0-A	001: Ch0-B
010: Ch1-A	011: Ch1-B
100: Ch2-A	101: Ch2-B
110: Ch3-A	111: Ch3-B
- [2:0] **EA2B\_MAP[2:0]**  
EA\_PWM\_2B channel mapping:
 

000: Ch0-A	001: Ch0-B
010: Ch1-A	011: Ch1-B
100: Ch2-A	101: Ch2-B
110: Ch3-A	111: Ch3-B

**EATTF0 External bridge tristate time from fault**

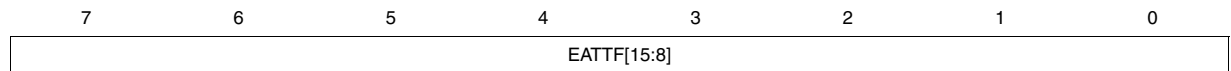

**Address:** 0x06

**Type:** RW

**Reset:** 0x00

**Description:** The tristate time is the time between fault deasserted and 3-state removed for the external bridge. It is calculated as EATTF[15:0] \* 41.66 μs

- [7:0] **EATTF[15:8]**  
MSBs of the EA tristate time factor

**EATTF1 External bridge tristate time from fault**

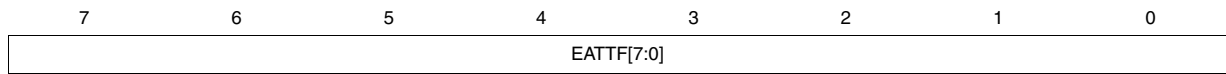

**Address:** 0x07  
**Type:** RW  
**Reset:** 0x03  
**Description:** See also register [EATTF0](#)

[7:0] EATTF[7:0]  
 LSBs of EA tristate time factor

**EATTP0 External bridge tristate time from powerdown**

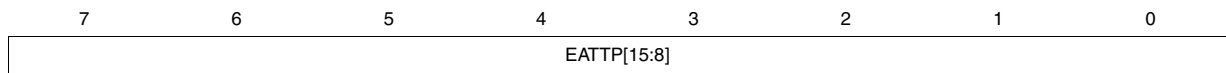

**Address:** 0x08  
**Type:** RW  
**Reset:** 0x00  
**Description:** This tristate time is the time between bridge powerdown removed and 3-state removed for the external bridge. It is calculated as EATTP[15:0] \* 41.66 μs

[7:0] EATTP[15:8]  
 MSBs of EA 3-state time after power-up factor

**EATTP1 External bridge tristate time from powerdown**

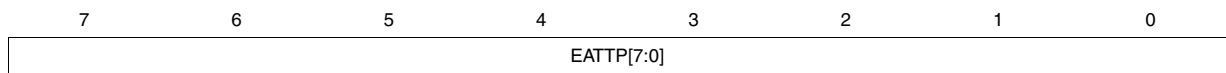

**Address:** 0x09  
**Type:** RW  
**Reset:** 0x03  
**Description:** See also register [EATTP0](#)

[7:0] EATTP[7:0]  
 LSBs of EA 3-state time after power-up factor

**CBTTF0 CMOS bridge tristate time from fault**

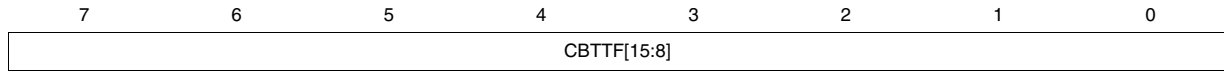

**Address:** 0x0A  
**Type:** RW  
**Reset:** 0x00  
**Description:** The tristate time is the time between fault deasserted and 3-state removed for the CMOS bridge. It is calculated as  $CBTTF[15:0] * 41.66 \mu s$

[7:0] **CBTTF[15:8]**  
 MSBs of CB 3-state time factor

**CBTTF1 CMOS bridge tristate time from fault**

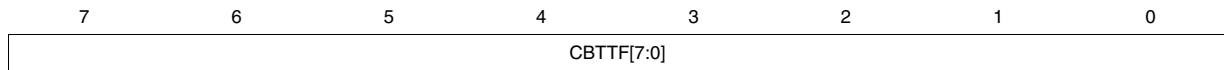

**Address:** 0x0B  
**Type:** RW  
**Reset:** 0x02  
**Description:** See also register [CBTTF0](#)

[7:0] **CBTTF[7:0]**  
 LSBs of CB 3-state time factor

**CBTTP0 CMOS bridge tristate time from powerdown**

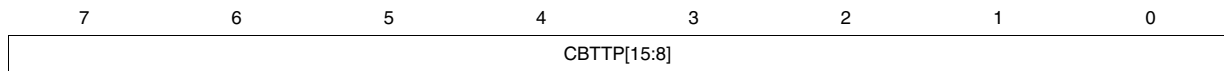

**Address:** 0x0C  
**Type:** RW  
**Reset:** 0x00  
**Description:** This tristate time is the time between bridge powerdown removed and 3-state removed for the CMOS bridge. It is calculated as  $CBTTP[15:0] * 41.66 \mu s$

[7:0] **CBTTP[15:8]**  
 MSBs of CB 3-state time after power-up factor

**CBTTP1** **CMOS bridge tristate time from powerdown**

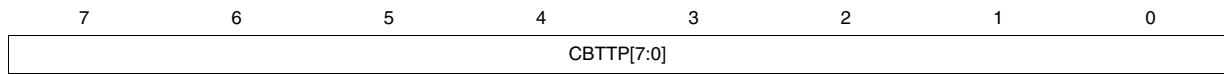

**Address:** 0x0D

**Type:** RW

**Reset:** 0x02

**Description:** See also register [CBTTP0](#)

[7:0] **CBTTP[7:0]**  
LSBs of CB 3-state time after power-up factor

**FFXST**

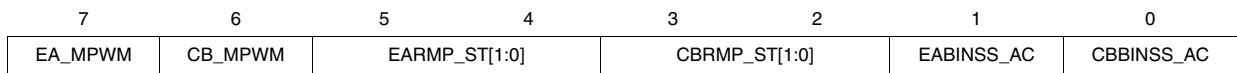

**Address:** 0x0E

**Type:** RO

**Reset:** 0xC0

**Description:**

- [7] **EA\_MPWM**  
1: EA is in mute
- [6] **CB\_MPWM**  
1: CB is in mute
- [5:4] **EARMP\_ST[1:0]**: pop free ramp status  
00: parked  
11: ready  
10: going to park  
01: going to ready
- [3:2] **CBRMP\_ST[1:0]**: pop free ramp status  
00: parked  
11: ready  
10: going to park  
01: going to ready
- [1] **EABINSS\_AC**  
1: ramp active (going to park or ready)
- [0] **CBBINSS\_AC**  
1: ramp active (going to park or ready)

**POWST** **Status register for external amplifier**

7	6	5	4	3	2	1	0
Reserved				EA_TW	EA_PD	EA_FT	EA_TS

**Address:** 0x0F

**Type:** RO

**Reset:** 0x05

**Description:**

- [7:4] **Reserved**
- [3] **EA\_TW**  
1: EA thermal warning
- [2] **EA\_PD**  
1: EA power-down
- [1] **EA\_FT**  
1: EA is in fault
- [0] **EA\_TS**  
1: EA is in 3-state

**POWST1** **Status register for CMOS bridge**

7	6	5	4	3	2	1	0
Reserved	CB_PD	CB_FT[2:0]			CB_TS[2:0]		

**Address:** 0x10

**Type:** RO

**Reset:** 0x47

**Description:**

- [7] **Reserved**
- [6] **CB\_PD**  
1: CMOS bridge is in power-down
- [5:3] **CB\_FT[2:0]**  
xx1: CMOS bridge channel 1 is in fault  
x1x: CMOS bridge channel 2 is in fault  
1xx: CMOS bridge channel 3 is in fault
- [2:0] **CB\_TS[2:0]**  
xx1: CMOS bridge channel 1 is in 3-state  
x1x: CMOS bridge channel 2 is in 3-state  
1xx: CMOS bridge channel 3 is in 3-state

**PWMO1CFG0**

7	6	5	4	3	2	1	0
AZPLS_1	TERNARY_1	HALFB_1	MP_ZERO_1	MIN_PLS_1[3:0]			

**Address:** 0x11

**Type:** RW

**Reset:** 0x20

**Description:**

- [7] AZPLS\_1  
1: avoid zero pulse
- [6] TERNARY\_1  
1: ternary modulation
- [5] HALFB\_1  
1: 1B is modulated as null signal
- [4] MP\_ZERO\_1  
1: apply the minimum pulse settings also for values near 0
- [3:0] MIN\_PLS\_1[3:0]  
minimum pulse length = clock period \* (MIN\_PLS\_1 + 1)

**PWMO1CFG1**

7	6	5	4	3	2	1	0
PM_1A[1:0]		PS_1A[5:0]					

**Address:** 0x12

**Type:** RW

**Reset:** 0x00

**Description:** Configuration for PWM-A

- [7:6] **PM\_1A[1:0]:** PWM mode  
00: generate a rising edge using a down carrier  
01: generate a falling edge using an up carrier  
10: hybrid mode: alternation of modes 00 and 01  
11: hybrid mode: alternation of modes 01 and 00
- [5:0] **PS\_1A[5:0]:** PWM shift  
The PWM waveform could be shifted by (PS\_1A \* clock period / 64)

**PWMO1CFG2**

7	6	5	4	3	2	1	0
PM_1B[1:0]		PS_1B[5:0]					

**Address:** 0x13  
**Type:** RW  
**Reset:** 0x48  
**Description:** Configuration for PWM-B

- [7:6] PM\_1B[1:0]: PWM mode
  - 00: generate a rising edge using a down carrier
  - 01: generate a falling edge using an up carrier
  - 10: ibrid mode: alternation of modes 00 and 01
  - 11: ibrid mode: alternation of modes 01 and 00
- [5:0] PS\_1B[5:0]: PWM shift
  - The PWM waveform could be shifted by (PS\_1B \* clock period / 64)

**PWMO2CFG0**

7	6	5	4	3	2	1	0
AZPLS_2	TERNARY_2	HALFB_2	MP_ZERO_2	MIN_PLS_2[3:0]			

**Address:** 0x14  
**Type:** RW  
**Reset:** 0x20  
**Description:**

- [7] AZPLS\_2
  - 1: avoid zero pulse
- [6] TERNARY\_2
  - 1: ternary modulation
- [5] HALFB\_2
  - 1: 2B is modulated as null signal
- [4] MP\_ZERO\_2
  - 1: apply the minimum pulse settings also for values near 0
- [3:0] MIN\_PLS\_2[3:0]
  - Minimum pulse length = clock period \* (MIN\_PLS\_2 + 1)

### PWMO2CFG1

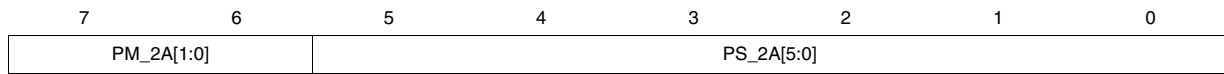

**Address:** 0x15

**Type:** RW

**Reset:** 0x10

**Description:**

- [7:6] **PM\_2A[1:0]:** PWM mode
  - 00: generate a rising edge using a down carrier
  - 01: generate a falling edge using an up carrier
  - 10: hybrid mode: alternation of modes 00 and 01
  - 11: hybrid mode: alternation of modes 01 and 00
- [5:0] **PS\_2A[5:0]:** PWM shift
  - The PWM waveform could be shifted by  $(PS\_2A * \text{clock period} / 64)$

### PWMO2CFG2



**Address:** 0x16

**Type:** RW

**Reset:** 0x58

**Description:**

- [7:6] **PM\_2B[1:0]:** PWM mode
  - 00: generate a rising edge using a down carrier
  - 01: generate a falling edge using an up carrier
  - 10: hybrid mode: alternation of modes 00 and 01
  - 11: hybrid mode: alternation of modes 01 and 00
- [5:0] **PS\_2B[5:0]:** PWM shift
  - The PWM waveform could be shifted by  $(PS\_2B * \text{clock period} / 64)$

**PWMO3CFG0**

7	6	5	4	3	2	1	0
AZPLS_3	TERNARY_3	HALFB_3	MP_ZERO_3	MIN_PLS_3[3:0]			

**Address:** 0x17

**Type:** RW

**Reset:** 0x00

**Description:**

- [7] AZPLS\_3  
1: avoid zero pulse
- [6] TERNARY\_3  
1: ternary modulation
- [5] HALFB\_3  
1: 3B is modulated as null signal
- [4] MP\_ZERO\_3  
1: apply the minimum pulse settings also for values near 0
- [3:0] MIN\_PLS\_3[3:0]  
Minimum pulse length = clock period \* (MIN\_PLS\_3 + 1)

**PWMO3CFG1**

7	6	5	4	3	2	1	0
PM_3A[1:0]		PS_3A[5:0]					

**Address:** 0x18

**Type:** RW

**Reset:** 0x20

**Description:**

- [7:6] **PM\_3A[1:0]:** PWM mode  
00: generate a rising edge using a down carrier  
01: generate a falling edge using an up carrier  
10: hybrid mode: alternation of modes 00 and 01  
11: hybrid mode: alternation of modes 01 and 00
- [5:0] PS\_3A[5:0]: PWM shift  
The PWM waveform could be shifted by (PS\_3A \* clock period / 64)

**PWMO3CFG2**

7	6	5	4	3	2	1	0
PM_3B[1:0]		PS_3B[5:0]					

**Address:** 0x19

**Type:** RW

**Reset:** 0x68

**Description:**

- [7:6] **PM\_3B[1:0]:** PWM mode
  - 00: generate a rising edge using a down carrier
  - 01: generate a falling edge using an up carrier
  - 10: hybrid mode: alternation of modes 00 and 01
  - 11: hybrid mode: alternation of modes 01 and 00
- [5:0] **PS\_3B[5:0]:** PWM shift
  - The PWM waveform could be shifted by (PS\_3B \* clock period / 64)

**PWMO4CFG0**

7	6	5	4	3	2	1	0
AZPLS_4	TERNARY_4	HALFB_4	MP_ZERO_4	MIN_PLS_4[3:0]			

**Address:** 0x1A

**Type:** RW

**Reset:** 0x00

**Description:**

- [7] **AZPLS\_4**
  - 1: avoid zero pulse
- [6] **TERNARY\_4**
  - 1: ternary modulation
- [5] **HALFB\_4**
  - 1: 4B is modulated as null signal
- [4] **MP\_ZERO\_4**
  - 1: apply the minimum pulse settings also for values near 0
- [3:0] **MIN\_PLS\_4[3:0]**
  - Minimum pulse length = clock period \* (MIN\_PLS\_4 + 1)

**PWMO4CFG1**

7	6	5	4	3	2	1	0
PM_4A[1:0]		PS_4A[5:0]					

**Address:** 0x1B**Type:** RW**Reset:** 0x30**Description:**[7:6] **PM\_4A[1:0]:** PWM mode

00: generate a rising edge using a down carrier

01: generate a falling edge using an up carrier

10: hybrid mode: alternation of modes 00 and 01

11: hybrid mode: alternation of modes 01 and 00

[5:0] **PS\_4A[5:0]:** PWM shiftThe PWM waveform could be shifted by  $(PS\_4A * \text{clock period} / 64)$ **PWMO4CFG2**

7	6	5	4	3	2	1	0
PM_4B[1:0]		PS_4B[5:0]					

**Address:** 0x1C**Type:** RW**Reset:** 0x78**Description:**[7:6] **PM\_4B[1:0]:** PWM mode

00: generate a rising edge using a down carrier

01: generate a falling edge using an up carrier

10: hybrid mode: alternation of modes 00 and 01

11: hybrid mode: alternation of modes 01 and 00

[5:0] **PS\_4B[5:0]:** PWM shiftThe PWM waveform could be shifted by  $(PS\_4B * \text{clock period} / 64)$

**CB\_PFRAMP1**

7	6	5	4	3	2	1	0
CBRMP_MP[5:0]						Reserved	

**Address:** 0x20**Type:** RW**Reset:** 0x14**Description:**

- [7:2] CBRMP\_MP[5:0]  
Minimum pulse width of the PDM signal
- [1:0] Reserved

**CB\_PFRAMP2**

7	6	5	4	3	2	1	0
CBRMPINI[15:8]							

**Address:** 0x21**Type:** RW**Reset:** 0x80**Description:** Initial value of the ramp signal

- [7:0] CBRMPINI[15:8]  
MSBs of CB ramp init

**CB\_PFRAMP3**

7	6	5	4	3	2	1	0
CBRMPINI[7:0]							

**Address:** 0x22**Type:** RW**Reset:** 0x3C**Description:**

- [7:0] CBRMPINI[7:0]  
LSBs of CB ramp init

**CB\_PFRAMP4**

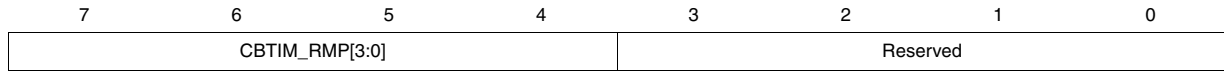

**Address:** 0x23

**Type:** RW

**Reset:** 0x10

**Description:**

- [7:4] CBTIM\_RMP[3:0]  
EA timing duration of the ramp (= slope)
- [3:0] Reserved

**CB\_PFRAMP5**

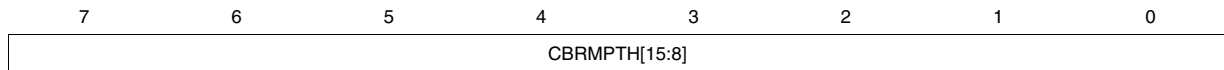

**Address:** 0x24

**Type:** RW

**Reset:** 0x14

**Description:** During the ramp, if the signal is below the threshold, the signal is modulated with PDM, otherwise with PWM

- [7:0] CBRMPH[15:8]  
MSBs of CB ramp threshold

**CB\_PFRAMP6**

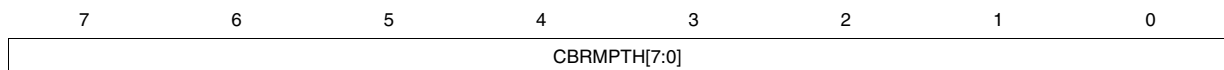

**Address:** 0x25

**Type:** RW

**Reset:** 0x00

**Description:** During the ramp, if the signal is below the threshold, the signal is modulated with PDM, otherwise with PWM

- [7:0] CBRMPH[7:0]  
LSBs of CB ramp threshold

**EA\_PFRAMP1**

7	6	5	4	3	2	1	0
EARMP_MP[5:0]						Reserved	

**Address:** 0x26**Type:** RW**Reset:** 0x1C**Description:**

- [7:2] EARMP\_MP[5:0]  
Minimum pulse width of the PDM signal
- [1:0] Reserved

**EA\_PFRAMP2**

7	6	5	4	3	2	1	0
EARMPINI[15:8]							

**Address:** 0x27**Type:** RW**Reset:** 0x80**Description:** Initial value of the ramp signal

- [7:0] EARMPINI[15:8]  
MSBs of EA ramp init

**EA\_PFRAMP3**

7	6	5	4	3	2	1	0
EARMPINI[7:0]							

**Address:** 0x28**Type:** RW**Reset:** 0x60**Description:**

- [7:0] EARMPINI[7:0]  
LSBs of EA ramp init

### EA\_PFRAMP4

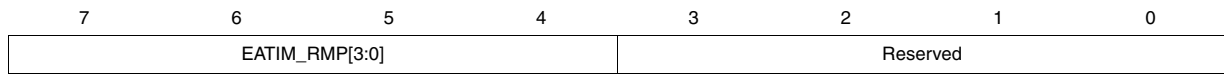

**Address:** 0x29

**Type:** RW

**Reset:** 0x10

**Description:**

- [7:4] EATIM\_RMP[3:0]  
EA timing duration of the ramp (= slope)
- [3:0] Reserved

### EA\_PFRAMP5

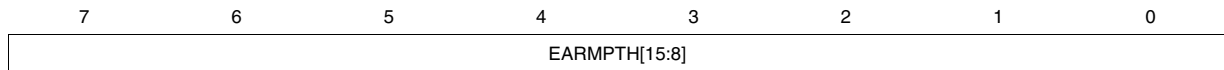

**Address:** 0x2A

**Type:** RW

**Reset:** 0x80

**Description:** During the ramp, if the signal is below the threshold, the signal is modulated with PDM, otherwise with PWM

- [7:0] EARMPTH[15:8]  
MSBs of EA ramp threshold

### EA\_PFRAMP6



**Address:** 0x2B

**Type:** RW

**Reset:** 0x60

**Description:** During the ramp, if the signal is below the threshold, the signal is modulated with PDM, otherwise with PWM

- [7:0] EARMPTH[7:0]  
LSBs of EA ramp threshold

**SRC1STATE**

7	6	5	4	3	2	1	0
SRC1_BYP[1:0]		SRC_1_LOCK	SRC1_FISFO[4:0]				

**Address:** 0x30  
**Type:** RO  
**Reset:** 0x8F  
**Description:** Values of  $f_S$  based on the 96 kHz as output frequency

- [7:6] SRC1\_BYP[1:0]  
 00: input signal has  $f_S < 78$  kHz  
 10: input signal has  $f_S > 81$  kHz
- [5] SRC\_1\_LOCK  
 0: SRC target frequency not reached  
 1: SRC1 target frequency reached
- [4:0] SRC1\_FISFO[4:0]  
 MSB  $Fs_{input} / Fs_{output}$

**SRC2STATE**

7	6	5	4	3	2	1	0
SRC1_BYP[1:0]		SRC_1_LOCK	SRC1_FISFO[4:0]				

**Address:** 0x31  
**Type:** RO  
**Reset:** 0x8F  
**Description:**

- [7:6] SRC2\_BYP[1:0]  
 00: Input Signal has  $f_S < 78$  kHz  
 10: Input Signal has  $f_S > 81$  kHz
- [5] SRC\_2\_LOCK  
 0: SRC target frequency not reached  
 1: SRC1 target frequency reached
- [4:0] SRC2\_FISFO[4:0]  
 MSB  $Fs_{input} / Fs_{output}$

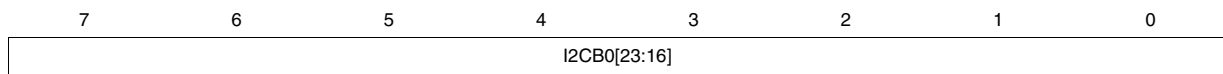
**I2CB0\_TOP****Address:** 0x51**Type:** RW**Reset:** 0x00**Description:**

[7:0] I2CB0[23:16]  
MSBs of coefficient b0

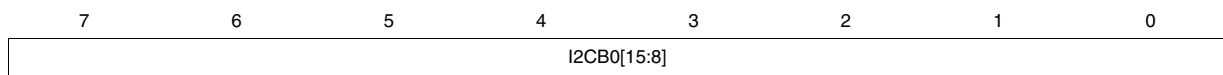
**I2CB0\_MID****Address:** 0x52**Type:** RW**Reset:** 0x00**Description:**

[7:0] I2CB0[15:8]  
Middle bits of coefficient b0

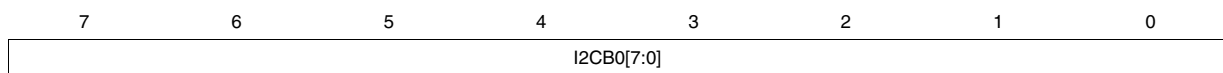
**I2CB0\_BOT****Address:** 0x53**Type:** RW**Reset:** 0x00**Description:**

[7:0] I2CB0[7:0]  
LSBs of coefficient b0

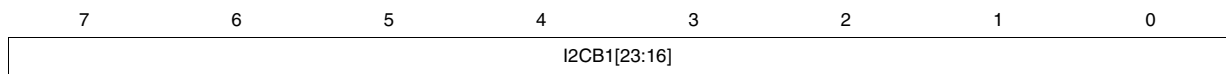
**I2CB1\_TOP****Address:** 0x54**Type:** RW**Reset:** 0x00**Description:**

[7:0] I2CB1[23:16]  
MSBs of coefficient b1

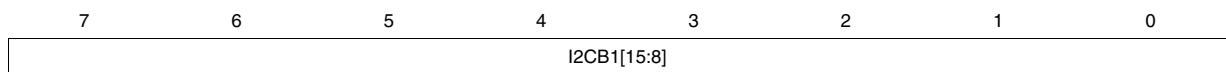
**I2CB1\_MID****Address:** 0x55**Type:** RW**Reset:** 0x00**Description:**

[7:0] I2CB1[15:8]  
Middle bits of coefficient b1

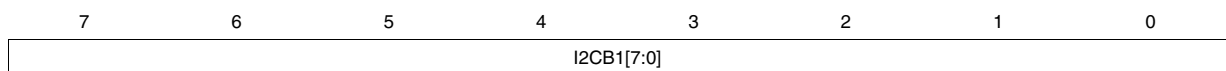
**I2CB1\_BOT****Address:** 0x56**Type:** RW**Reset:** 0x00**Description:**

[7:0] I2CB1[7:0]  
LSBs of coefficient b1

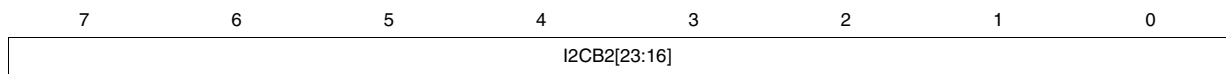
**I2CB2\_TOP****Address:** 0x57**Type:** RW**Reset:** 0x00**Description:**

[7:0] I2CB2[23:16]  
MSBs of coefficient b2

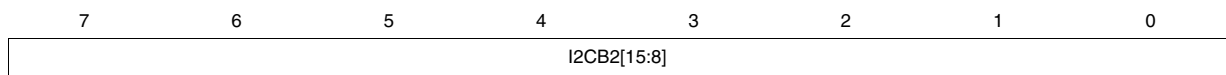
**I2CB2\_MID****Address:** 0x58**Type:** RW**Reset:** 0x00**Description:**

[7:0] I2CB2[15:8]  
Middle bits of coefficient b2

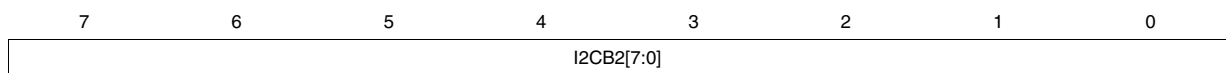
**I2CB2\_BOT****Address:** 0x59**Type:** RW**Reset:** 0x00**Description:**

[7:0] I2CB2[7:0]  
LSBs of coefficient b2

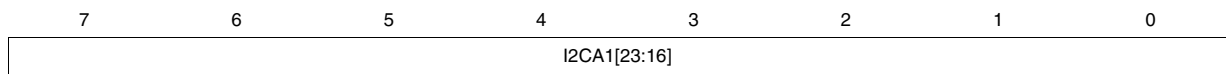
**I2CA1\_TOP****Address:** 0x5A**Type:** RW**Reset:** 0x00**Description:**

[7:0] I2CA1[23:16]  
MSBs of coefficient a1

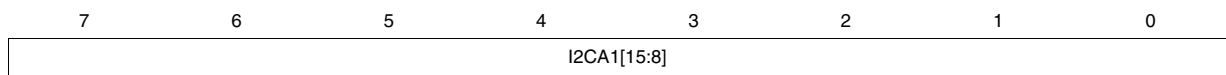
**I2CA1\_MID****Address:** 0x5B**Type:** RW**Reset:** 0x00**Description:**

[7:0] I2CA1[15:8]  
Middle bits of coefficient a1

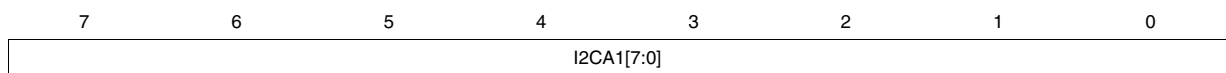
**I2CA1\_BOT****Address:** 0x5C**Type:** RW**Reset:** 0x00**Description:**

[7:0] I2CA1[7:0]  
LSBs of coefficient a1

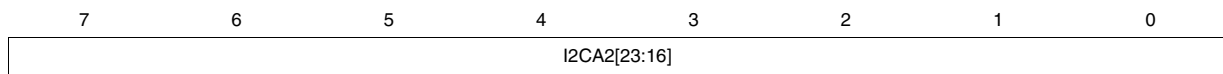
**I2CA2\_TOP****Address:** 0x5D**Type:** RW**Reset:** 0x00**Description:**

[7:0] I2CA2[23:16]  
MSBs of coefficient a2

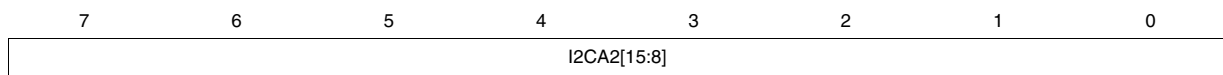
**I2CA2\_MID****Address:** 0x5E**Type:** RW**Reset:** 0x00**Description:**

[7:0] I2CA2[15:8]  
Middle bits of coefficient a2

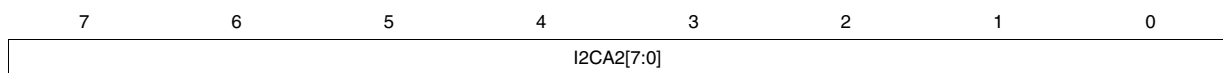
**I2CA2\_BOT****Address:** 0x5F**Type:** RW**Reset:** 0x00**Description:**

[7:0] I2CA2[7:0]  
LSBs of coefficient a2

**PROCCTRL**

7	6	5	4	3	2	1	0
Reserved				RA	Reserved	WA	W1

**Address:** 0x60**Type:** RO**Reset:** 0x00**Description:**[7:4] **Reserved**

[3] RA

1: read all the biquad coefficients

[2] Reserved

[1] WA

1: write/update all the biquad coefficients

[0] W1

1: write/update the b0 coefficient

**START\_ADDR2**

7	6	5	4	3	2	1	0
Reserved							I2CSTART_A8

**Address:** 0x61**Type:** RW**Reset:** 0x00**Description:**

[7:1] Reserved

[0] I2CSTART\_A8

Base address of the biquadratic to be updated (= address of coefficient b0)

**START\_ADDR1**

7	6	5	4	3	2	1	0
I2CSTART_A7_A0							

**Address:** 0x62**Type:** RW**Reset:** 0x00**Description:**

[7:0] I2CSTART\_A7\_A0

Base address of the biquadratic to be updated (= address of the b0 coefficient)

**ROM\_REMAP**

7	6	5	4	3	2	1	0
Reserved	ENAB_PRE3	ENAB_PRE2	ENAB_PRE1	ENAB_PRE0	ENAB_POST	ENAB_PRMIX	ENAB_DELAY

**Address:** 0x6F**Type:** RW**Reset:** 0x00**Description:**[7] **Reserved**

[6] ENAB\_PRE3

0: pre scale value of channel 3 taken from RAM  
1: pre scale value of channel 3 taken from ROM

[5] ENAB\_PRE2

0: pre scale value of channel 2 taken from RAM  
1: pre scale value of channel 2 taken from ROM

[4] ENAB\_PRE1

0: pre scale value of channel 1 taken from RAM  
1: pre scale value of channel 1 taken from ROM

[3] ENAB\_PRE0

0: pre scale value of channel 0 taken from RAM  
1: pre scale value of channel 0 taken from ROM

[2] ENAB\_POST

0: post mix values taken from RAM  
1: post mix values taken from ROM

[1] ENAB\_PRMIX

0: pre mix values taken from RAM  
1: pre mix values taken from ROM

[0] ENAB\_DELAY

0: Delay values taken from RAM  
1: Delay values taken from ROM

**BYP\_EN\_CH0**

7	6	5	4	3	2	1	0
Reserved							

**Address:** 0x70**Type:** RW**Reset:** 0x00**Description:**[7:0] **Reserved****EFFS\_EN\_CH0**

7	6	5	4	3	2	1	0
Reserved						EROM09	EROM08

**Address:** 0x71**Type:** RW**Reset:** 0x00**Description:**[7:2] **Reserved**[1] EROM09  
1: enable de-emphasis EQ on channel 0[0] EROM08  
1: enable high-pass filter on channel 0**BYP\_EN\_CH1**

7	6	5	4	3	2	1	0
Reserved							

**Address:** 0x72**Type:** RW**Reset:** 0x00**Description:**[7:0] **Reserved**

**EFFS\_EN\_CH1**

7	6	5	4	3	2	1	0
Reserved						EROM19	Reserved

**Address:** 0x73**Type:** RW**Reset:** 0x00**Description:**[7:2] **Reserved**

[1] EROM19

1: enable de-emphasis EQ on channel 1

[0] Reserved

**BYP\_EN\_CH2**

7	6	5	4	3	2	1	0
Reserved							

**Address:** 0x74**Type:** RW**Reset:** 0x00**Description:**

[7:0] Reserved

**EFFS\_EN\_CH2**

7	6	5	4	3	2	1	0
Reserved						EROM29	EROM28

**Address:** 0x75**Type:** RW**Reset:** 0x00**Description:**[7:2] **Reserved**

[1] EROM29

1: enable de-emphasis EQ on channel 2

[0] EROM28

1: enable high-pass filter on channel 2

**BYP\_EN\_CH3**

7	6	5	4	3	2	1	0
Reserved							

**Address:** 0x76

**Type:** RW

**Reset:** 0x00

**Description:**

[7:0] **Reserved**

**EFFS\_EN\_CH3**

7	6	5	4	3	2	1	0
Reserved						EROM39	Reserved

**Address:** 0x77

**Type:** RW

**Reset:** 0x00

**Description:**

[7:2] **Reserved**

[1] EROM39

1: enable de-emphasis EQ on channel 3

[0] **Reserved**

**BASS\_SELO\_R**

7	6	5	4	3	2	1	0
Reserved		BASS_EN0	BASS_SELO				

**Address:** 0x78

**Type:** RW

**Reset:** 0x00

**Description:**

[7:6] **Reserved**

[5] BASS\_EN0

0: Bass EQ of channel 0 is not active

1: Bass EQ of channel 0 is active

[4:0] BASS\_SELO

Select the gain of the bass filter from -12 dB (00000) to +12 dB using [Table 35](#) below

**BASS\_SEL1\_R**

7	6	5	4	3	2	1	0
Reserved		BASS_EN1					
		BASS_SEL1					

**Address:** 0x79**Type:** RW**Reset:** 0x00**Description:**

[7:6] Reserved

[5] BASS\_EN1

0: Bass EQ of channel 1 is not active

1: Bass EQ of channel 1 is active

[4:0] BASS\_SEL1

Select the gain of the bass filter from -12 dB (00000) to +12 dB using [Table 35](#) below**BASS\_SEL2\_R**

7	6	5	4	3	2	1	0
Reserved		BASS_EN2					
		BASS_SEL2					

**Address:** 0x7A**Type:** RW**Reset:** 0x00**Description:**

[7:6] Reserved

[5] BASS\_EN2

0: Bass EQ of channel 2 is not active

1: Bass EQ of channel 2 is active

[4:0] BASS\_SEL2

Select the gain of the bass filter from -12 dB (00000) to +12 dB using [Table 35](#) below

**BASS\_SEL3\_R**

7	6	5	4	3	2	1	0
Reserved		BASS_EN3	BASS_SEL3				

**Address:** 0x7B**Type:** RW**Reset:** 0x00**Description:**

[7:6] Reserved

[5] BASS\_EN3

0: Bass EQ of channel 3 is not active

1: Bass EQ of channel 3 is active

[4:0] BASS\_SEL3

Select the gain of the bass filter from -12 dB (00000) to +12 dB using [Table 35](#) below**TREB\_SELO\_R**

7	6	5	4	3	2	1	0
Reserved		TREB_EN0	TREB_SELO				

**Address:** 0x7C**Type:** RW**Reset:** 0x00**Description:**

[7:6] Reserved

[5] TREB\_EN0

0: Treble EQ of channel 0 is not active

1: Treble EQ of channel 0 is active

[4:0] TREB\_SELO

Select the gain of the treble filter from -12 dB (00000) to +12 dB using [Table 35](#) below

**TREB\_SEL1\_R**

7	6	5	4	3	2	1	0
Reserved		TREB_EN1					
		TREB_SEL1					

**Address:** 0x7D

**Type:** RW

**Reset:** 0x00

**Description:**

- [7:6] Reserved
- [5] TREB\_EN1
  - 0: Treble EQ of channel 1 is not active
  - 1: Treble EQ of channel 1 is active
- [4:0] TREB\_SEL1
  - Select the gain of the treble filter from -12 dB (00000) to +12 dB using [Table 35](#) below

**TREB\_SEL2\_R**

7	6	5	4	3	2	1	0
Reserved		TREB_EN2					
		TREB_SEL2					

**Address:** 0x7E

**Type:** RW

**Reset:** 0x00

**Description:**

- [7:6] Reserved
- [5] TREB\_EN2
  - 0: Treble EQ of channel 2 is not active
  - 1: Treble EQ of channel 2 is active
- [4:0] TREB\_SEL2
  - Select the gain of the treble filter from -12 dB (00000) to +12 dB using [Table 35](#) below

**TREB\_SEL3\_R**

7	6	5	4	3	2	1	0
Reserved		TREB_EN3					
		TREB_SEL3					

**Address:** 0x7F

**Type:** RW

**Reset:** 0x00

**Description:**

[7:6] Reserved

[5] TREB\_EN3

0: Treble EQ of channel 3 is not active

1: Treble EQ of channel 3 is active

[4:0] TREB\_SEL3

Select the gain of the treble filter from -12 dB (00000) to +12 dB using [Table 35](#) below

**Table 35. Bass/treble filter gains used in register addresses 0x78 - 0x7F**

BASS_SELx TREBLE_SELx	Gain	BASS_SELx TREBLE_SELx	Gain
11000	+12	-	-
10111	+11	01011	-01
10110	+10	01010	-02
10101	+09	01001	-03
10100	+08	01000	-04
10011	+07	00111	-05
10010	+06	00110	-06
10001	+05	00101	-07
10000	+04	00100	-08
01111	+03	00011	-09
01110	+02	00010	-10
01101	+01	00001	-11
01100	+00	00000	-12

### SATCH0CFG1

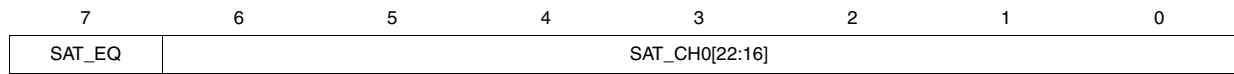

**Address:** 0x90

**Type:** RW

**Reset:** 0xFF

**Description:**

- [7] SAT\_EQ
  - 0: saturation value of every channel is independent
  - 1: all the channels take the saturation value of channel 0
- [6:0] SAT\_CH0[22:16]
  - MSBs of the absolute saturation value for channel 0.
  - If the signal is above SAT\_CH0[22:0] then it is truncated

### SATCH0CFG2

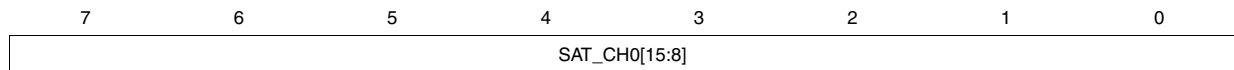

**Address:** 0x91

**Type:** RW

**Reset:** 0xFF

**Description:**

- [7:0] SAT\_CH0[15:8]
  - Middle bits of the saturation value for channel 0
  - If the signal is above SAT\_CH0[22:0] then it is truncated

### SATCH0CFG3

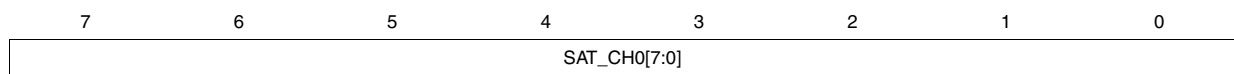

**Address:** 0x92

**Type:** RW

**Reset:** 0xFF

**Description:**

- [7:0] SAT\_CH0[7:0]
  - LSBs of the saturation value for channel 0
  - If the signal is above SAT\_CH0[22:0] then it is truncated

### SATCH1CFG1

7	6	5	4	3	2	1	0
Reserved	SAT_CH1[22:16]						

**Address:** 0x93

**Type:** RW

**Reset:** 0x00

**Description:**

[7] Reserved

[6:0] SAT\_CH1[22:16]

MSBs of the absolute saturation value for channel 1.

If the signal is above SAT\_CH1[22:0] then it is truncated, see also register bit [SATCH0CFG1\[7\]](#)

### SATCH1CFG2

7	6	5	4	3	2	1	0
SAT_CH1[15:8]							

**Address:** 0x94

**Type:** RW

**Reset:** 0x00

**Description:**

[7:0] SAT\_CH1[15:8]

Middle bits of the saturation value for channel 1

If the signal is above SAT\_CH1[22:0] then it is truncated, see also register bit [SATCH0CFG1\[7\]](#)

### SATCH1CFG3

7	6	5	4	3	2	1	0
SAT_CH1[7:0]							

**Address:** 0x95

**Type:** RW

**Reset:** 0x00

**Description:**

[7:0] SAT\_CH1[7:0]

LSBs of the saturation value for channel 1

If the signal is above SAT\_CH1[22:0] then it is truncated, see also register bit [SATCH0CFG1\[7\]](#)

**SATCH2CFG1**

7	6	5	4	3	2	1	0
Reserved	SAT_CH2[22:16]						

**Address:** 0x96**Type:** RW**Reset:** 0x00**Description:**

[7] Reserved

[6:0] SAT\_CH2[22:16]

MSBs of the absolute saturation value for channel 2.

If the signal is above SAT\_CH2[22:0] then it is truncated, see also register bit [SATCH0CFG1](#)[7]**SATCH2CFG2**

7	6	5	4	3	2	1	0
SAT_CH2[15:8]							

**Address:** 0x97**Type:** RW**Reset:** 0x00**Description:**

[7:0] SAT\_CH2[15:8]

Middle bits of the saturation value for channel 2

If the signal is above SAT\_CH2[22:0] then it is truncated, see also register bit [SATCH0CFG1](#)[7]**SATCH2CFG3**

7	6	5	4	3	2	1	0
SAT_CH2[7:0]							

**Address:** 0x98**Type:** RW**Reset:** 0x00**Description:**

[7:0] SAT\_CH2[7:0]

LSBs of the saturation value for channel 2

If the signal is above SAT\_CH2[22:0] then it is truncated, see also register bit [SATCH0CFG1](#)[7]

### SATCH3CFG1

7	6	5	4	3	2	1	0
Reserved	SAT_CH3[22:16]						

**Address:** 0x99

**Type:** RW

**Reset:** 0x00

**Description:**

[7] Reserved

[6:0] SAT\_CH3[22:16]

MSBs of the absolute saturation value for channel 3.

If the signal is above SAT\_CH3[22:0] then it is truncated, see also register bit [SATCH0CFG1\[7\]](#)

### SATCH3CFG2

7	6	5	4	3	2	1	0
SAT_CH3[15:8]							

**Address:** 0x9A

**Type:** RW

**Reset:** 0x00

**Description:**

[7:0] SAT\_CH3[15:8]

Middle bits of the saturation value for channel 3

If the signal is above SAT\_CH3[22:0] then it is truncated, see also register bit [SATCH0CFG1\[7\]](#)

### SATCH3CFG3

7	6	5	4	3	2	1	0
SAT_CH3[7:0]							

**Address:** 0x9B

**Type:** RW

**Reset:** 0x00

**Description:**

[7:0] SAT\_CH3[7:0]

LSBs of the saturation value for channel 3

If the signal is above SAT\_CH3[22:0] then it is truncated, see also register bit [SATCH0CFG1\[7\]](#)

**VOLCFG**

7	6	5	4	3	2	1	0
SVOL_ON3	SVOL_ON2	SVOL_ON1	SVOL_ON0	TIM_SVOL			

**Address:** 0xA0  
**Type:** RW  
**Reset:** 0xF5  
**Description:** The register sets up the soft volume control

- [7] SVOL\_ON3  
0: volume on channel 3 is updated immediately  
1: volume on channel 3 is updated gradually with a ramp
- [6] SVOL\_ON2  
0: volume on channel 2 is updated immediately  
1: volume on channel 2 is updated gradually with a ramp
- [5] SVOL\_ON1  
0: volume on channel 1 is updated immediately  
1: volume on channel 1 is updated gradually with a ramp
- [4] SVOL\_ON0  
0: volume on channel 0 is updated immediately  
1: volume on channel 0 is updated gradually with a ramp
- [3:0] TIM\_SVOL  
Set the volume ramp; each volume step (0.5 dB) takes  $(2^{\text{TIM\_SVOL}} / f_s)$  s

**MVOL****Master volume control**

7	6	5	4	3	2	1	0
MVOL							

**Address:** 0xA1  
**Type:** RW  
**Reset:** 0x00  
**Description:**

- [7:0] MVOL  
Master volume from 0 dB to -127.5 dB in 0.5 dB steps (volume = MVOL \* 0.5 dB)

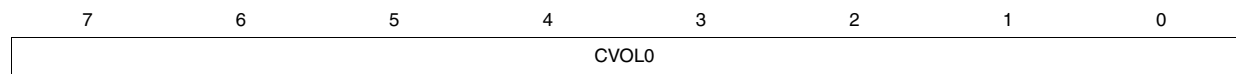
**VOLCH0** **Channel 0 volume control****Address:** 0xA2**Type:** RW**Reset:** 0x48**Description:**

[7:0] CVOL0  
Channel 0 volume 36 dB to -91.5 dB in 0.5 dB steps

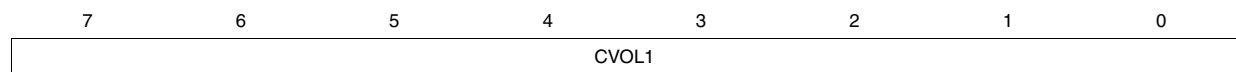
**VOLCH1** **Channel 1 volume control****Address:** 0xA3**Type:** RW**Reset:** 0x48**Description:**

[7:0] CVOL1  
Channel 1 volume 36 dB to -91.5 dB in 0.5 dB steps

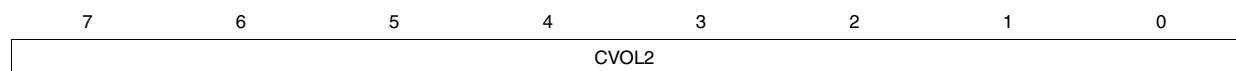
**VOLCH2** **Channel 2 volume control****Address:** 0xA4**Type:** RW**Reset:** 0x48**Description:**

[7:0] CVOL2  
Channel 2 volume 36 dB to -91.5 dB in 0.5 dB steps

**VOLCH3** Channel 3 volume control

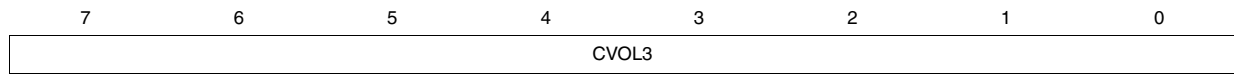

**Address:** 0xA5

**Type:** RW

**Reset:** 0x48

**Description:**

[7:0] CVOL3  
Channel 3 volume 36 dB to -91.5 dB in 0.5 dB steps

**SAI\_IN1\_CFG0**

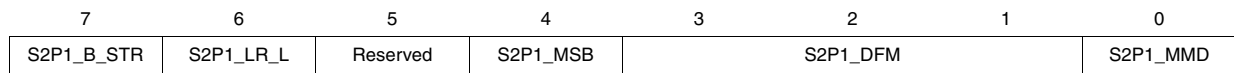

**Address:** 0xB0

**Type:** RW

**Reset:** 0xD2

**Description:**

- [7] S2P1\_B\_STR  
BICKLK strobe  
0: active\_edge = rising, strb\_edge = falling  
1: active\_edge = falling, strb\_edge = rising
- [6] S2P1\_LR\_L  
LRCLK strobe  
0: left = 0, right = 1  
1: left = 1, right = 0
- [5] Reserved
- [4] S2P1\_MSB  
MSB first
- [3:1] S2P1\_DFM[2:0]  
Data format  
000: left justified  
001: I<sup>2</sup>S  
010: right justified  
100: PCM no-delay  
101: PCM delay  
111: DSP
- [0] S2P1\_MMD  
Master mode

**SAI\_IN1\_CFG1**

7	6	5	4	3	2	1	0
S2P1_DLEN		S2P1_BOS		S2P1_MAP_L		S2P1_MAP_R	

**Address:** 0xB1**Type:** RW**Reset:** 0x91**Description:**

[7:6] S2P1\_DLEN

Data length

00: 8 bits

01: 16 bits

10: 24 bits

11: 32 bits

[5:4] S2P1\_BOS

BICKL\_OS

00: BICKL = 32 \* f<sub>S</sub>01: BICKL = 64 \* f<sub>S</sub>10: BICKL = 128 \* f<sub>S</sub>11: BICKL = 256 \* f<sub>S</sub>

[3:2] S2P1\_MAP\_L

Map left

00: slot 0

01: slot 1

10: slot 2

11: slot 3

[1:0] S2P1\_MAP\_R

Map right

00: slot 0

01: slot 1

10: slot 2

11: slot 3

**SAI\_OUT\_CFG0**

7	6	5	4	3	2	1	0
P2S_B_STR	P2S_LR_L	SDATA0_ACT	P2S_MSB	P2S_DFM		P2S_MMD	

**Address:** 0xB2**Type:** RW**Reset:** 0xD3**Description:**

- [7] P2S\_B\_STR  
BICKLK strobe  
0: active\_edge = rising, strb\_edge = falling  
1: active\_edge = falling, strb\_edge = rising
- [6] P2S\_LR\_L  
LRCLK strobe  
0: left = 0, right = 1  
1: left = 1, right = 0
- [5] SDATA0\_ACT  
0: normal behavior  
1: SDATA0 is disabled
- [4] P2S\_MSB  
MSB first
- [3:1] P2S\_DFM[2:0]  
Data format  
000: left justified  
001: I<sup>2</sup>S  
010: right justified  
100: PCM no-delay  
101: PCM delay  
111: DSP
- [0] P2S\_MMD  
Master mode

**SAI\_OUT\_CFG1**

7	6	5	4	3	2	1	0
P2S_DLEN		P2S_BOS		P2S_MAP_L		P2S_MAP_R	

**Address:** 0xB3**Type:** RW**Reset:** 0x91**Description:**

[7:6] P2S\_DLEN

Data length

00: 08 bits

01: 16 bits

10: 24 bits

11: 32 bits

[5:4] P2S\_BOS

BICKL\_OS

00: BICKL = 32 \* f<sub>S</sub>01: BICKL = 64 \* f<sub>S</sub>10: BICKL = 128 \* f<sub>S</sub>11: BICKL = 256 \* f<sub>S</sub>

[3:2] P2S\_MAP\_L

Map left

00: slot 0

01: slot 1

10: slot 2

11: slot 3

[1:0] P2S\_MAP\_R

Map right

00: slot 0

01: slot 1

10: slot 2

11: slot 3

**SAI\_IN2\_CFG0**

7	6	5	4	3	2	1	0
S2P2_B_STR	S2P2_LR_L	Reserved	S2P2_MSB	S2P2_DFM			S2P2_MMD

**Address:** 0xB4**Type:** RW**Reset:** 0xD2**Description:**

- [7] S2P2\_B\_STR  
BICKLK strobe  
0: active\_edge = rising, strb\_edge = falling  
1: active\_edge = falling, strb\_edge = rising
- [6] S2P2\_LR\_L  
LRCLK strobe  
0: left = 0, right = 1  
1: left = 1, right = 0
- [5] Reserved
- [4] S2P2\_MSB  
MSB first
- [3:1] S2P2\_DFM[2:0]  
Data format  
000: left justified  
001: I<sup>2</sup>S  
010: right justified  
100: PCM no-delay  
101: PCM delay  
111: DSP
- [0] S2P2\_MMD  
Master mode

**SAI\_IN2\_CFG1**

7	6	5	4	3	2	1	0
S2P2_DLEN		S2P2_BOS		S2P2_MAP_L		S2P2_MAP_R	

**Address:** 0xB5**Type:** RW**Reset:** 0x91**Description:****[7:6] S2P2\_DLEN**

Data length

00: 8 bits

01: 16 bits

10: 24 bits

11: 32 bits

**[5:4] S2P2\_BOS**

BICKL\_OS

00: BICKL = 32 \*  $f_S$ 01: BICKL = 64 \*  $f_S$ 10: BICKL = 128 \*  $f_S$ 11: BICKL = 256 \*  $f_S$ **[3:2] S2P2\_MAP\_L**

Map left

00: slot 0

01: slot 1

10: slot 2

11: slot 3

**[1:0] S2P2\_MAP\_R**

Map right

00: slot 0

01: slot 1

10: slot 2

11: slot 3

### AUIFSHARE

7	6	5	4	3	2	1	0
Reserved						SHARE_BILR	

**Address:** 0xB6

**Type:** RW

**Reset:** 0x00

**Description:**

- [7:2] Reserved
- [1:0] SHARE\_BILR
  - 00: no clock sharing
  - 01: SAI\_in1, SAI\_in2 share the clocks: BICLK1 and LRCLK1 (others are not used)
    - SAI1: can be master/slave (see config)
    - SAI2: always slave
  - 10: SAI\_in1, SAI\_in2, SAI\_out share the clocks: BICLK1 and LRCLK1 (others are not used)
    - SAI\_out: can be master/slave (see config)
    - SAI1 and SAI2: always slave
  - 11: no clock sharing

### SRCINSEL

7	6	5	4	3	2	1	0
SRC1_INSEL		SRC2_INSEL		MUTE_SRCU	Reserved		

**Address:** 0xB7

**Type:** RW

**Reset:** 0x28

**Description:**

- [7:6] SRC1\_INSEL
  - Sample rate converter IN channels 0 and 1:
  - 00: serial audio interface IN 1
  - 01: ADC
  - 1x: serial audio interface IN 2
- [5:4] SRC2\_INSEL
  - Sample rate converter IN channels 2 and 3:
  - 00: serial audio interface IN 1
  - 01: ADC
  - 1x: serial audio interface IN 2
- [3] MUTE\_SRCU0:
  - 1: The device will be put in mute if the SRC is not locked at the 96 kHz sample frequency
- [2:0] Reserved

**P2SDATA**

7	6	5	4	3	2	1	0
Reserved	P2S_HFS	P2S1_DSEL			P2S2_DSEL		

**Address:** 0xB8

**Type:** RW

**Reset:** 0x00

**Description:**

- [7] Reserved
- [6] P2S\_HFS  
SAI OUT:  
0: 96 kHz  
1: half processing frequency (48 kHz)

- [5:3] P2S1\_DSEL  
SAI OUT 1  
000: ADC  
001: SAI IN 1  
010: SAI IN 2  
011: SRC channels 0-1  
100: SRC channels 2-3  
101: processing channels 0 - 1  
110: processing channels 2 - 3

- [2:0] P2S2\_DSEL  
SAI OUT 2  
000: ADC  
001: SAI IN 1  
010: SAI IN 2  
011: SRC channels 0-1  
100: SRC channels 2-3  
101: processing channels 0 - 1  
110: processing channels 2 - 3

**PLLCFG0**

7	6	5	4	3	2	1	0
PLL_DPROG	PLL_FR_CTRL	PLL_DDIS		PLL_IDF			

**Address:** 0xC0**Type:** RW**Reset:** 0x00**Description:**

[7] 0: PLL takes the internal settings  
 1: PLL takes the register settings

[6] PLL\_FR\_CTRL  
 0: fractional frequency synthesis disabled  
 1: fractional frequency synthesis enabled

[5:4] PLL\_DDIS  
 PLL dither disable  
 x0: triangular PDF dither input enabled  
 x1: triangular PDF dither input disabled  
 0x: rectangular PDF dither input enabled  
 1x: rectangular PDF dither input disabled

[3:0] PLL\_IDF  
 Set the input division factor of the PLL (see [Section 5.3: Fractional PLL on page 31](#))

**PLLCFG1**

7	6	5	4	3	2	1	0
PLL_FRAC[15:8]							

**Address:** 0xC1**Type:** RW**Reset:** 0x00**Description:** See also [Section 5.3: Fractional PLL on page 31](#)

[7:0] PLL\_FRAC[15:8]  
 The MSBs of PLL\_FRAC[15:0] which is used to set the PLL multiplication factor

**PLLCFG2**

7	6	5	4	3	2	1	0
PLL_FRAC[7:0]							

**Address:** 0xC2**Type:** RW**Reset:** 0x00**Description:** See also [Section 5.3: Fractional PLL on page 31](#)

[7:0] PLL\_FRAC[7:0]

The LSBs of PLL\_FRAC[15:0] which is used to set the PLL multiplication factor

**PLLCFG3**

7	6	5	4	3	2	1	0
PLL_STRB	PLL_STRBBYP	PLL_NDIV					

**Address:** 0xC3**Type:** RW**Reset:** 0x00**Description:** See also [Section 5.3: Fractional PLL on page 31](#)

[7] PLL\_STRB

0: normal behaviour

1: asynchronous strobe input, a new configuration input is loaded into the fraction controller

[6] PLL\_STRBBYP

0: normal behaviour

1: bypass the strobe signal

[5:0] PLL\_NDIV

Set the PLL multiplication factor (integral part), loop division factor (LDF)

**PLL PFE**

7	6	5	4	3	2	1	0
PLL_BYP_UNL	BICLK2PLL	PLL_PWDN	PLL_NOPDDIV	Reserved			

**Address:** 0xC4

**Type:** RW

**Reset:** 0x80

**Description:**

- [7] PLL\_BYP\_UNL  
0: PLL clock is not bypassed if it is unlock  
1: PLL clock is bypassed if it is unlock, the external clock is used as system clock
- [6] BICLK2PLL  
PLL clock in selection  
0: normal behaviour  
1: BICLK1 is used as PLL clock source
- [5] PLL\_PWDN  
0: normal behaviour  
1: PLL goes into power-down mode
- [4] PLL\_NOPDDIV  
0: PLL goes to power-down when the divider settings are changed  
1: PLL remains active when the divider settings are changed
- [3:0] Reserved

**PLLST**

**PLL status**

7	6	5	4	3	2	1	0
PLL_UNLOCK	PLL_PWD_ST	PLL_BYP_ST	Reserved				

**Address:** 0xC5

**Type:** RO

**Reset:** 0x00

**Description:**

- [7] PLL\_UNLOCK  
0: normal behaviour  
1: PLL is not locked
- [6] PLL\_PWD\_ST  
0: normal behaviour  
1: PLL is in power-down mode
- [5] PLL\_BYP\_ST  
0: PLL is selected  
1: PLL is bypassed

[4:0] Reserved

## ADCCFG0

7	6	5	4	3	2	1	0
ADC_PGA			ADC_INSEL	ADC_STBY	ADC_BYPCAL	CLK_ADC_ON	Reserved

**Address:** 0xC6

**Type:** RW

**Reset:** 0x00

### Description:

- [7:5] ADC\_PGA  
Programmable gain amplifier:  
000: 0 dB  
001: +6 dB  
010: +12 dB  
011: +18 dB  
100: +24 dB  
101: +30 dB  
110: +36 dB  
111: +42 dB
- [4] ADC\_INSEL  
0: line input mode selected  
1: mike input mode selected
- [3] ADC\_STBY  
0: ADC normal mode  
1: ADC standby mode for power reduction
- [2] ADC\_BYPCAL  
0: DC-removal block enabled  
1: bypass DC-removal block
- [1] CLK\_ADC\_ON  
0: ADC clock disabled  
1: ADC clock active
- [0] Reserved

**CKOCFG**

7	6	5	4	3	2	1	0
CLKOUT_DIS	CLKOUT_SEL		CLK_FFX_ON	CLK_SRC_ON	CLK_PROC_ON	EAPWM_DIS	PWM00ACT

**Address:** 0xC7**Type:** RW**Reset:** 0x1C**Description:**

- [7] CLKOUT\_DIS  
0: CLKOUT is enabled  
1: CLKOUT is disabled
- [6:5] CLKOUT\_SEL  
00: system clock / 4  
01: system clock / 2  
10: system clock / 4  
11: system clock / 8
- [4] CLK\_FFX\_ON  
0: FFX clock disabled  
1: FFX clock active
- [3] CLK\_SRC\_ON  
0: sample rate converter clock disabled  
1: sample rate converter clock active
- [2] CLK\_PROC\_ON  
0: process block clock disabled  
1: process block clock active
- [1] EAPWM\_DIS  
0: EA PWM output is enable  
1: EA PWM output is disabled
- [0] PWM00ACT  
0: output PWM00 is at logical 0  
1: Output PWM00 is active

**MISC**

7	6	5	4	3	2	1	0
OSC_DIS	S2P_FS_RNG			ADC_FS_RNG		Reserved	CLK_CORE_ON

**Address:** 0xC8**Type:** RW**Reset:** 0x20**Description:**

## [7] OSC\_DIS

0: normal behaviour

1: XT oscillator is disabled

## [6:4] S2P\_FS\_RNG

Serial audio interface sampling frequency,  $f_S$ , range:

000: 8 - 12 kHz (very low)

001: 16 - 24 kHz (low)

010: 32 - 48 kHz (normal)

011: 64 - 96 kHz (high)

100: 128 - 192 kHz (very high)

## [3:2] ADC\_FS\_RNG

ADC sampling frequency,  $f_S$ , range:

00: 32 - 48 kHz (normal)

01: 16 - 24 kHz (low)

1x: 8 - 12 kHz (very low)

## [1] Reserved

## [0] CLK\_CORE\_ON

0: core clock disabled

1: core clock active

**PLL\_B**

7	6	5	4	3	2	1	0
PLL_BYP	Reserved	ADC_CLKSEL	Reserved	P2S1_CLKSEL	Reserved	P2S2_CLKSEL	Reserved

**Address:** 0xC9

**Type:** RW

**Reset:** 0x80

**Description:** See also [Figure 11: Clock management scheme on page 29](#)

- [7] PLL\_BYP  
0: PLL not bypassed  
1: PLL bypassed
- [6] Reserved
- [5] ADC\_CLKSEL  
0: clk\_adc / 4  
1: pll\_clk\_in
- [4] Reserved
- [3] P2S1\_CLKSEL  
0: processing clock  
1: pll\_clk\_in
- [2] Reserved
- [1] P2S2\_CLKSEL  
0: processing clock  
1: pll\_clk\_in
- [0] Reserved

**HPDET1**

7	6	5	4	3	2	1	0
HPD_SEL	HPD_POL	HPD_ACT_MODE		HPD_HPMOD	HPD_TIM_F		

**Address:** 0xCA**Type:** RW**Reset:** 0x40**Description:**

[7] HPD\_SEL  
Select the headphone detection threshold  
0: HP1  
1: HP2

[6] HPD\_POL  
Polarity of the detection signal

[5:4] HPD\_ACT\_MODE  
Action to be done in case of detection:  
00: inactive  
01: mute EA and un-mute CB  
10: 3-state EA and un-3-state CB  
11: power-down EA and power-up CB

[3] HPD\_HPMOD  
0: normal behaviour  
1: FFX is in headphone modulation mode

[2:0] HPD\_TIM\_F  
000: 1.33 ms  
001: 2.66 ms  
010: 5.33 ms  
011: 10.66 ms  
100: 21.33 ms  
101: 42.66 ms  
110: 85.33 ms  
111: 170.67 ms

**HPDET2**

7	6	5	4	3	2	1	0
E_HP2	E_HP1	TUD_EN	Reserved			E_HPDET1	E_HPDET2

**Address:** 0xCB

**Type:** RW

**Reset:** 0xC0

**Description:**

- [7] E\_HP2  
0: headphone detection 2 is disabled  
1: headphone detection 2 is enabled
- [6] E\_HP1  
0: headphone detection 1 is disabled  
1: headphone detection 1 is enabled
- [5] TUD\_EN  
1: disable the pull-up resistor of the headphones detector
- [4:2] Reserved
- [1] E\_HPDET1  
Headphone 1 detector line (not filtered)
- [0] E\_HPDET2  
Headphone 2 detector line (not filtered)

**HPDST**

**Headphone detection status**

7	6	5	4	3	2	1	0
HPD_DET_FILT	Reserved						

**Address:** 0xCC

**Type:** RO

**Reset:** 0x00

**Description:**

- [7] HPD\_DET\_FILT  
0: no headphones  
1: headphones detected
- [6:0] Reserved

**STBY\_MODES**

7	6	5	4	3	2	1	0
PAD_PULDIS	Reserved					CMP_EN_N	DC_STBY_EN_N

**Address:** 0xCD

**Type:** RW

**Reset:** 0x00

**Description:**

[7] PAD\_PULDIS  
 0: Enable the pull (up/down) of the pads  
 1: Disable the pull (up/down) of the pads

[6:2] Reserved

[1] CMP\_EN\_N  
 0: compensation cell is active  
 1: compensation cell goes into power-down mode when pin STBY is asserted

[0] DC\_STBY\_EN\_N  
 0: DC regulators are active  
 1: DC regulators go into power-down mode when pin STBY is asserted

**ADCCFG1**

**ADC analog input selection**

7	6	5	4	3	2	1	0
ADC_ANA_SEL		Reserved					

**Address:** 0xCE

**Type:** RW

**Reset:** 0x00

**Description:**

[7:6] ADC\_ANA\_SEL  
 00: INL1, INR1  
 01: INL2, INR2  
 1x: reserved

[5:0] Reserved

**PFEFAULT**

7	6	5	4	3	2	1	0
Reserved			PFE1	PFE2	PFE3	RESET_EA_FT	RESET_CB_FT

**Address:** 0xCF**Type:** RW**Reset:** 0x00**Description:**

[7:5] Reserved

[4] PFE1

0: analog pop free disabled on bridge output 1  
 1: analog pop free enabled bridge output 1

[3] PFE2

0: analog pop free disabled on bridge output 2  
 1: analog pop free enabled bridge output 2

[2] PFE3

0: analog pop free disabled on bridge output 3  
 1: analog pop free enabled bridge output 3

[1] RESET\_EA\_FT

0: normal operation  
 1: reset register bit [POWST\[1\]](#)

[0] RESET\_CB\_FT

0: normal operation  
 1: reset register bits [POWST1\[5:3\]](#)

**BISTRUN0**

**BIST control**

7	6	5	4	3	2	1	0
SF1_BRUN	SF2_BRUN	SS1_BRUN	SS2_BRUN	CF_BRUN	PR_BRUN	CF_ROM_BRUN	Reserved

**Address:** 0xD0

**Type:** RW

**Reset:** 0x00

**Description:**

- [7] SF1\_BRUN  
SRC1 RAM  
0: normal functional mode  
1: start the BIST
- [6] SF2\_BRUN  
SRC2 RAM  
0: normal functional mode  
1: start the BIST
- [5] SS1\_BRUN  
SRC1 RAM  
0: normal functional mode  
1: start the BIST
- [4] SS2\_BRUN  
SRC2 RAM  
0: normal functional mode  
1: start the BIST
- [3] CF\_BRUN  
PROC RAM (coefficients)  
0: normal functional mode  
1: start the BIST
- [2] PR\_BRUN  
PROC RAM (program)  
0: normal functional mode  
1: start the BIST
- [1] CF\_ROM\_BRUN  
PROC RAM (coefficients)  
0: normal functional mode  
1: start the BIST
- [0] Reserved

**BISTRUN1**

7	6	5	4	3	2	1	0
OS_BRUN	DB_BRUN	Reserved					

**Address:** 0xD1

**Type:** RW

**Reset:** 0x00

**Description:**

- [7] OS\_BRUN  
FFX RAM  
0: normal functional mode  
1: start the BIST
- [6] DB\_BRUN  
FFX RAM  
0: normal functional mode  
1: start the BIST
- [5:0] Reserved

**BISTST0**

**BIST status register 0**

7	6	5	4	3	2	1	0
SF1_BEND	SF1_BBAD	SF1_BFAIL	SF2_BEND	SF2_BBAD	SF2_BFAIL	SS1_BEND	SS1_BBAD

**Address:** 0xD2

**Type:** RO

**Reset:** 0x00

**Description:**

- [7] SF1\_BEND:  
For SRC1 RAM BIST  
0: normal functional mode  
1: BIST is finished
- [6] SF1\_BBAD  
For SRC1 RAM BIST  
0: no faults detected  
1: at least one fault detected
- [5] SF1\_BFAIL  
For SRC1 RAM BIST  
0: no faults detected in the current location  
1: at least one fault detected in the current location

- [4] SF2\_BEND  
For SRC2 RAM BIST  
0: normal functional mode  
1: BIST is finished
- [3] SF2\_BBAD  
For SRC2 RAM BIST  
0: no faults detected  
1: at least one fault detected
- [2] SF2\_BFAIL  
For SRC2 RAM BIST  
0: no faults detected in the current location  
1: at least one fault detected in the current location
- [1] SS1\_BEND  
For SRC1 RAM BIST  
0: normal functional mode  
1: BIST is finished
- [0] SS1\_BBAD  
For SRC1 RAM BIST  
0: no faults detected  
1: at least one fault detected

**BISTST1****BIST status register 1**

7	6	5	4	3	2	1	0
SS1_BFAIL	SS2_BEND	SS2_BBAD	SS2_BFAIL	CF_BEND	CF_BBAD	CF_BFAIL	PR_BEND

**Address:** 0xD3**Type:** RO**Reset:** 0x00**Description:**

- [7] SS1\_BFAIL  
For SRC1 RAM BIST  
0: no faults detected in the current location  
1: at least one fault detected in the current location
- [6] SS2\_BEND:  
For SRC2 RAM BIST  
0: normal functional mode  
1: BIST is finished
- [5] SS2\_BBAD  
For SRC2 RAM BIST  
0: no faults detected  
1: at least one fault detected
- [4] SS2\_BFAIL  
For SRC2 RAM BIST  
0: no faults detected in the current location  
1: at least one fault detected in the current location
- [3] CF\_BEND:  
For PROC RAM BIST  
0: normal functional mode  
1: BIST is finished
- [2] CF\_BBAD  
For PROC RAM BIST  
0: no faults detected  
1: at least one fault detected
- [1] CF\_BFAIL  
For PROC RAM BIST  
0: no faults detected in the current location  
1: at least one fault detected in the current location
- [0] PR\_BEND:  
For PROC RAM BIST  
0: normal functional mode  
1: BIST is finished

**BISTST2** **BIST status register 2**

7	6	5	4	3	2	1	0
PR_BBAD	PR_BFAIL	OS_BEND	OS_BBAD	OS_BFAIL	DB_BEND	DB_BBAD	DB_BFAIL

**Address:** 0xD4

**Type:** RO

**Reset:** 0x00

**Description:**

- [7] PR\_BBAD  
For PROC RAM BIST  
0: no faults detected  
1: at least one fault detected
- [6] PR\_BFAIL  
For PROC RAM BIST  
0: no faults detected in the current location  
1: at least one fault detected in the current location
- [5] OS\_BEND:  
For FFX RAM BIST  
0: normal functional mode  
1: BIST is finished
- [4] OS\_BBAD  
For FFX RAM BIST  
0: no faults detected  
1: at least one fault detected
- [3] OS\_BFAIL  
For FFX RAM BIST  
0: no faults detected in the current location  
1: at least one fault detected in the current location
- [2] DB\_BEND:  
For FFX RAM BIST  
0: normal functional mode  
1: BIST is finished
- [1] DB\_BBAD  
For FFX RAM BIST  
0: no faults detected  
1: at least one fault detected
- [0] DB\_BFAIL  
For FFX RAM BIST  
0: no faults detected in the current location  
1: at least one fault detected in the current location

**BISTST3****BIST status register 3**

7	6	5	4	3	2	1	0
CF_ROM_BEND	Reserved						

**Address:** 0xD5

**Type:** RO

**Reset:** 0x00

**Description:**

[7] CF\_ROM\_BEND  
ROM BIST computation is finished

[6:0] Reserved

**ROMSIGN0****ROM BIST signature (LSBs)****Address:** 0xD6**Type:** RO**Reset:** 0x00**Description:**

[7:0] CF\_ROMS[7:0]  
 LSBs of ROM BIST signature CF\_ROMS[23:0]

**ROMSIGN1****ROM BIST signature (middle bits)****Address:** 0xD7**Type:** RO**Reset:** 0x00**Description:**

[7:0] CF\_ROMS[15:8]  
 Middle bits of ROM BIST signature CF\_ROMS[23:0]

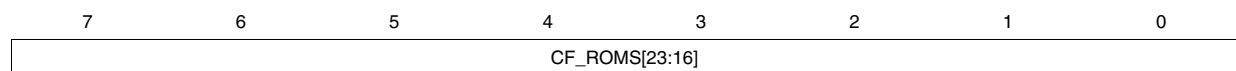
**ROMSIGN2****ROM BIST signature (MSBs)****Address:** 0xD8**Type:** RO**Reset:** 0x00**Description:**

[7:0] CF\_ROMS[23:16]  
 MSBs of ROM BIST signature CF\_ROMS[23:0]

**DEBUG0**

7	6	5	4	3	2	1	0
DBGCKO_ON		DBGCKO_VAL					

**Address:** 0xD9**Type:** RW**Reset:** 0x00**Description:**

[7] DBGCKO\_ON

0: normal behaviour

1: CLKOUT exports internal clocks as defined by bits DBGCKO\_VAL

[6:0] DBGCKO\_VAL

0x00: invalid\_inp\_fbk

0x01: mute\_int\_fbk

0x02: binss\_fbk

0x21: debug\_start

0x22: debug\_data\_end

0x23: debug\_data\_ok

0x24: debug\_lrcclk\_old

0x25: debug\_biclk

0x40: clk\_proc

0x41: clk\_src

0x42: clk\_ffx

0x50: src\_1\_lock

0x51: src\_2\_lock

0x52: src\_1\_bypass\_state[0]

0x53: src\_1\_bypass\_state[1]

0x54: src\_2\_bypass\_state[0]

0x55: src\_2\_bypass\_state[1]

0x56: pwm\_sync

0x57: s2p\_1\_bad\_clocks

0x58: s2p\_2\_bad\_clocks

0x59: s2p\_1\_missing\_biclk

all other values: no clock exported

**PADST0****Pad status 0**

7	6	5	4	3	2	1	0
PAD_RSTN	Reserved	PAD_SCL	PAD_SDA	PAD_I2CDIS	Reserved		PAD_STBY

**Address:** 0xF0**Type:** RO**Reset:** 0xA0**Description:**

- [7] PAD\_RSTN
- [6] Reserved
- [5] PAD\_SCL
- [4] PAD\_SDA
- [3] PAD\_I2CDIS
- [2:1] Reserved
- [0] PAD\_STBY

**PADST1**

7	6	5	4	3	2	1	0
PAD_MUTE	PAD_BICLKI	PAD_LRCLKI	PAD_SDATAI	PAD_BICLKO	PAD_LRCLKO	Reserved	

**Address:** 0xF1**Type:** RW**Reset:** 0x74**Description:**

- [7] PAD\_MUTE
- [6] PAD\_BICLKI
- [5] PAD\_LRCLKI
- [4] PAD\_SDATAI
- [3] PAD\_BICLKO
- [2] PAD\_LRCLKO
- [1:0] Reserved

# 15 I<sup>2</sup>C disabled (microless) mode

Figure 55. Microless mode block diagram

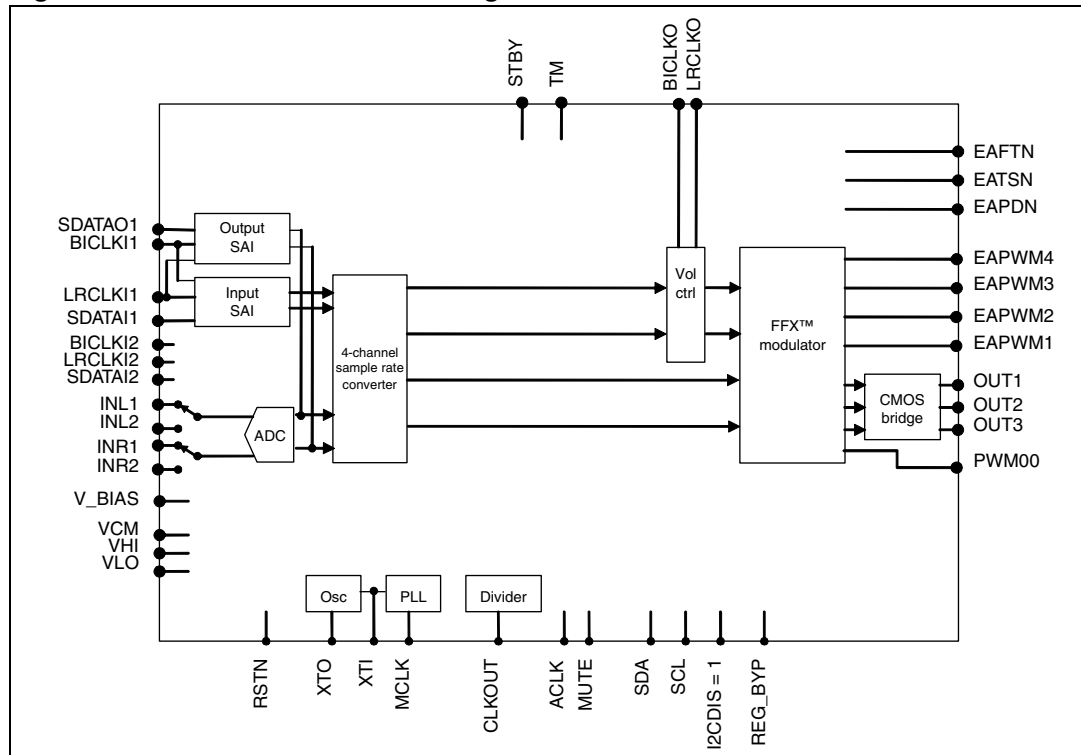

In microless mode (I2CDIS = 1) the I<sup>2</sup>C interface is inhibited and SDA and SCL are used as static inputs. The device is working in the configuration shown in *Figure 55* with the ADC connected to input line 1 and to SAI out. The processing chain uses the inputs from SAI input 1. The working modes are selected via the logical levels on the inputs SDA, SCL as follows:

- SCL = 0 : CMOS bridge outputs come from digital input serial audio interface;  
SCL = 1 : CMOS bridge outputs come from analog ADC input.
- SDA = 0 : external amplifier outputs come from digital input serial audio interface;  
SDA = 1 : external amplifier outputs come from analog ADC input.

At power-up the channel volume is set to -60 dB. The volume is controlled by pulsing the inputs LRCLKO and BICLKO as follows:

- when pulsing LRCLKO = 1 and BICLKO = 1 simultaneously the channel volume is set to 0 dB.
- Any LRCLKO = 1 pulse causes a channel volume decrease of 0.5 dB.
- Any BICLKO = 1 pulse causes a channel volume increase of 0.5 dB.

The channel volume change applies only to the external amplifier.

The digital output serial audio interface is always fed with the result of the ADC conversion with no volume control (line-out mode). It is in master mode when SCL = 1 and SDA = 1 otherwise it is in slave mode. It is configured in I<sup>2</sup>S format.

The LRCLK and BICLK signals are shared between input and output SAI.

The input sampling frequency must be between 32 kHz and 48 kHz and the master clock input (MCLK or XTI) must be  $256 * f_S$ .

The CMOS bridge FFX output is configured in line-out mode:

- left channel binary on OUT1
- right channel binary on OUT2
- zero signal binary (duty cycle 50%) on OUT3
- pop-free digital ramp active
- volume control not effective (always 0 dB)
- switching frequency 384 kHz.

The external amplifier FFX output is configured in BTL mode:

- left channel BTL (new ternary modulation) on EAPWM1 and EAPWM2
- right channel BTL (new ternary modulation) on EAPWM1 and EAPWM2
- volume control is effective
- switching frequency 384 kHz.

The headphone detection is disabled.

The CLKOUT pad is active at the PLL frequency of  $2048 * f_S$ .

# 16 Package mechanical data

The STA321 comes in a 64-pin, 10 mm x 10 mm, LQFP, exposed pad down (EPD) package. The reference number is JEDEC MS-026-BCD-HD.

In order to meet environmental requirements, ST offers these devices in different grades of ECOPACK® packages, depending on their level of environmental compliance. ECOPACK® specifications, grade definitions and product status are available at: [www.st.com](http://www.st.com). ECOPACK® is an ST trademark.

**Figure 56. LQFP-64L EPD outline drawing**

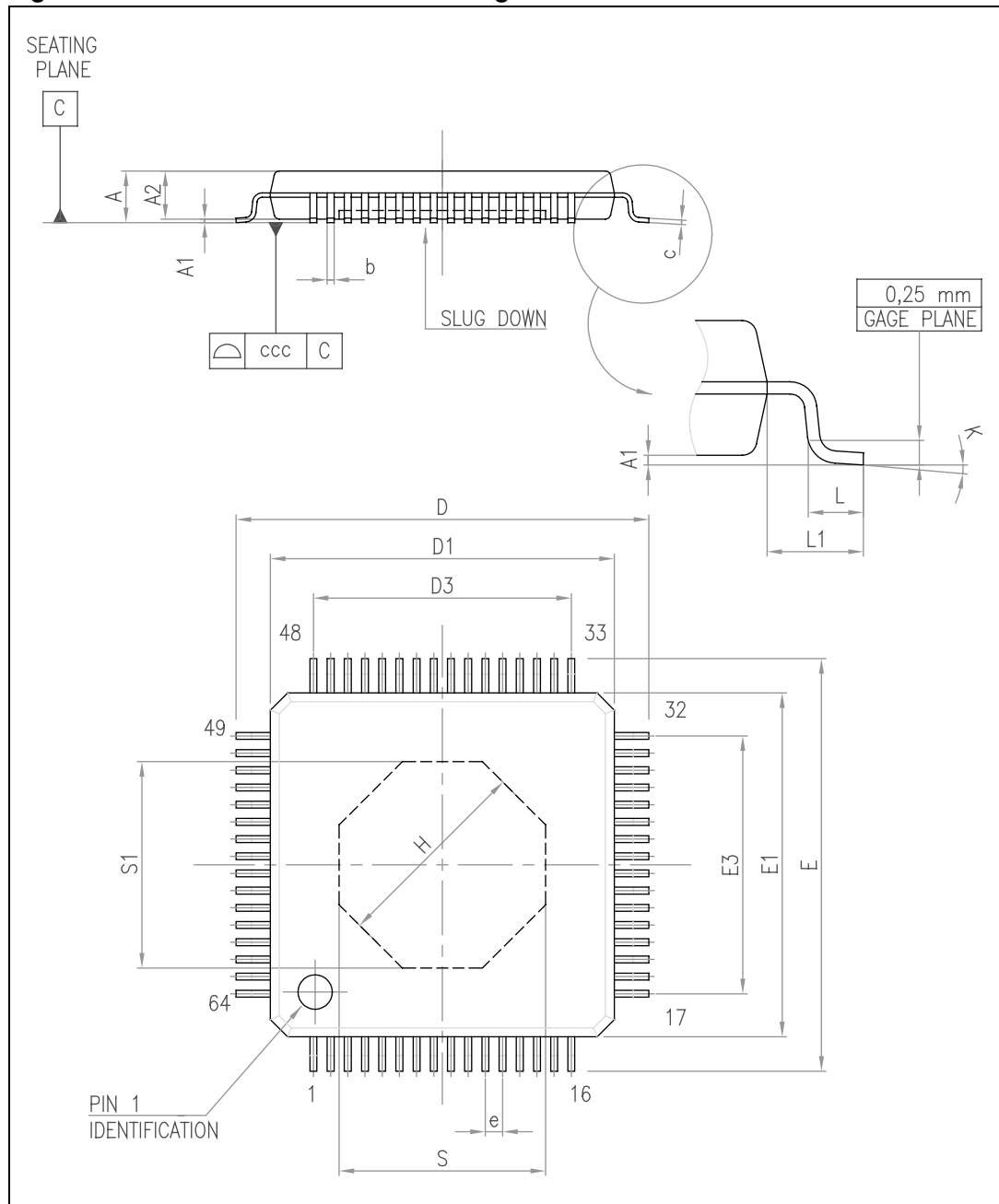

Table 36. LQFP-64L EPD dimensions

Symbol	Dimensions in mm			Dimensions in inches			Notes
	Min	Typ	Max	Min	Typ	Max	
A	-	-	1.60	-	-	0.063	-
A1	0.05	-	0.15	0.002	-	0.006	-
A2	1.35	1.40	1.45	0.053	0.055	0.057	-
b	0.17	0.22	0.27	0.007	0.009	0.011	-
c	0.09	-	0.20	0.004	-	0.008	-
D	11.80	12.00	12.20	0.465	0.472	0.480	-
D1	9.80	10.00	10.20	0.386	0.394	0.402	-
D3	-	7.50	-	-	0.295	-	-
E	11.80	12.00	12.20	0.465	0.472	0.480	-
E1	9.80	10.00	10.20	0.386	0.394	0.402	-
E3	-	7.50	-	-	0.295	-	-
e	-	0.50	-	-	0.020	-	-
H	-	5.89	-	-	0.232	-	-
L	0.45	0.60	0.75	0.018	0.024	0.030	-
L1	-	1.00	-	-	0.039	-	-
S	6.00	-	-	0.236	-	-	Exposed pad
S1	6.00	-	-	0.236	-	-	Exposed pad
ccc	-	-	0.08	-	-	0.003	-
k	0	3.5	7.0	0	3.5	7.0	Degrees

## 17 Glossary

### **Total harmonic distortion + noise (THDN)**

The ratio of the RMS value of all the spectral components in the specified band (20 Hz - 20 kHz) to the RMS values of the signal fundamental component. THDN is measured at 0 dBfs input at a frequency of 1 kHz.

### **Signal to noise plus distortion ratio (SNDR)**

Ratio between power of signal fundamental component and “noise+distortion”. It is measured at different input levels: 0 dBfs, -3 dBfs, -6 dBfs, -10 dBfs, -20 dBfs, -40 dBfs, -60 dBfs. When the signal amplitude is less than 0 dBfs, that much dB is added to obtain the final SNR. For example, if SNDR is 87 dB with -6dBfs signal, then  $SNR = 87 + 6 = 93$  dB.

### **Dynamic range (DR)**

Dynamic range is measured using SNDR at -60 dBfs, 1 kHz signal and adding 60 dB. For example, if SNDR with -60 dBfs is 38 dB then the dynamic range is  $38 + 60 = 98$  dB.

### **Crosstalk**

Crosstalk is the measure of the inter-channel isolation between the left and right channels of a stereo system. It is measured at each output with zero input to the channel under test and a full-scale input applied to the other channel.

### **Deviation from linear phase**

Measurement bandwidth 20 Hz to 20 kHz,  $f_s = 48$  kHz. The measurement takes into account the combined digital and analog filter characteristics.

### **Pass band, pass-band ripple, stop band, stop-band attenuation**

These parameters take into account both analog and digital filter characteristics. Stop-band attenuation should be measured between  $0.55 * f_s$  and  $3.45 * f_s$ .

## 18 Trademarks and other acknowledgements

SoundTerminal, FFX and pfStart are trademarks of STMicroelectronics.  
ECOPACK is a registered trademark of STMicroelectronics.

## 19 Revision history

**Table 37. Document revision history**

Date	Revision	Changes
27-Mar-2009	1	Initial release.
11-May-2009	2	Updated <a href="#">Table 1: Device summary on page 1</a> Added ambient temperature to <a href="#">Table 5: Recommended operating conditions on page 13</a> Updated <a href="#">Table 6: Electrical specifications on page 14</a> Updated resistor to 32 $\Omega$ in <a href="#">Figure 3: Test circuit on page 17</a> Updated and moved Headphone detector threshold limits table from <a href="#">Chapter 12 on page 72</a> and merged into <a href="#">Table 6: Electrical specifications on page 14</a> Updated HPDET2 bitfield in <a href="#">Table 34: Register summary on page 77</a> Updated description of register <a href="#">HPDET2 on page 138</a>
30-Oct-2009	3	Updates to feature list <a href="#">on page 1</a> Updated <a href="#">Chapter 1: Overview on page 9</a> Updated <a href="#">Chapter 16: Package mechanical data on page 152</a>

**Please Read Carefully:**

Information in this document is provided solely in connection with ST products. STMicroelectronics NV and its subsidiaries ("ST") reserve the right to make changes, corrections, modifications or improvements, to this document, and the products and services described herein at any time, without notice.

All ST products are sold pursuant to ST's terms and conditions of sale.

Purchasers are solely responsible for the choice, selection and use of the ST products and services described herein, and ST assumes no liability whatsoever relating to the choice, selection or use of the ST products and services described herein.

No license, express or implied, by estoppel or otherwise, to any intellectual property rights is granted under this document. If any part of this document refers to any third party products or services it shall not be deemed a license grant by ST for the use of such third party products or services, or any intellectual property contained therein or considered as a warranty covering the use in any manner whatsoever of such third party products or services or any intellectual property contained therein.

**UNLESS OTHERWISE SET FORTH IN ST'S TERMS AND CONDITIONS OF SALE ST DISCLAIMS ANY EXPRESS OR IMPLIED WARRANTY WITH RESPECT TO THE USE AND/OR SALE OF ST PRODUCTS INCLUDING WITHOUT LIMITATION IMPLIED WARRANTIES OF MERCHANTABILITY, FITNESS FOR A PARTICULAR PURPOSE (AND THEIR EQUIVALENTS UNDER THE LAWS OF ANY JURISDICTION), OR INFRINGEMENT OF ANY PATENT, COPYRIGHT OR OTHER INTELLECTUAL PROPERTY RIGHT.**

**UNLESS EXPRESSLY APPROVED IN WRITING BY AN AUTHORIZED ST REPRESENTATIVE, ST PRODUCTS ARE NOT RECOMMENDED, AUTHORIZED OR WARRANTED FOR USE IN MILITARY, AIR CRAFT, SPACE, LIFE SAVING, OR LIFE SUSTAINING APPLICATIONS, NOR IN PRODUCTS OR SYSTEMS WHERE FAILURE OR MALFUNCTION MAY RESULT IN PERSONAL INJURY, DEATH, OR SEVERE PROPERTY OR ENVIRONMENTAL DAMAGE. ST PRODUCTS WHICH ARE NOT SPECIFIED AS "AUTOMOTIVE GRADE" MAY ONLY BE USED IN AUTOMOTIVE APPLICATIONS AT USER'S OWN RISK.**

Resale of ST products with provisions different from the statements and/or technical features set forth in this document shall immediately void any warranty granted by ST for the ST product or service described herein and shall not create or extend in any manner whatsoever, any liability of ST.

ST and the ST logo are trademarks or registered trademarks of ST in various countries.

Information in this document supersedes and replaces all information previously supplied.

The ST logo is a registered trademark of STMicroelectronics. All other names are the property of their respective owners.

© 2009 STMicroelectronics - All rights reserved

STMicroelectronics group of companies

Australia - Belgium - Brazil - Canada - China - Czech Republic - Finland - France - Germany - Hong Kong - India - Israel - Italy - Japan - Malaysia - Malta - Morocco - Philippines - Singapore - Spain - Sweden - Switzerland - United Kingdom - United States of America

[www.st.com](http://www.st.com)

