



## TS2007FC

3 W filter-free class-D audio power amplifier  
with 6 or 12 dB fixed gain select

### Features

- Operates from  $V_{CC} = 2.4\text{ V}$  to  $5.5\text{ V}$
- Standby mode active low
- Output power:  $1.4\text{ W}$  at  $5\text{ V}$  or  $0.5\text{ W}$  at  $3.0\text{ V}$  into  $8\ \Omega$  with 1% THD+N max.
- Output power:  $2.3\text{ W}$  at  $5\text{ V}$  or  $0.75\text{ W}$  at  $3.0\text{ V}$  into  $4\ \Omega$  with 1% THD+N max.
- Two fixed gain selects: 6 dB or 12 dB
- Low current consumption
- Efficiency: 86% typical
- Signal-to-noise ratio: 90 dB typical
- PSRR: 68 dB typical at 217 Hz with 6 dB gain
- PWM base frequency: 280 kHz
- Low pop and click noise
- Thermal shutdown protection
- Output short-circuit protection
- Flip-chip lead-free 9-bump package with back coating in option

### Applications

- Cellular phones
- PDAs
- Notebook PCs

### Description

The TS2007FC is a class-D power audio amplifier. Able to drive up to  $1.4\text{ W}$  into an  $8\ \Omega$  load at  $5\text{ V}$ , it achieves better efficiency than typical class-AB audio power amplifiers.

This device can switch between two gain settings, 6 dB or 12 dB via a logic signal on the gain select pin. The pop and click reduction circuitry provides low on/off switching noise and allows the device to start within 1 ms typically.

TS2007EIJT - 9-bump flip-chip

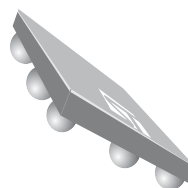

Pinout (top view)

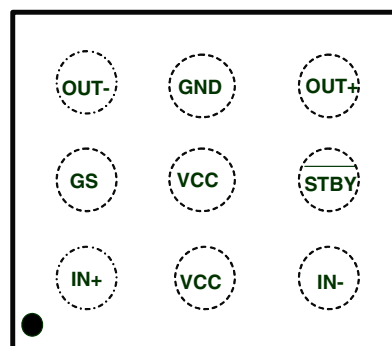

A standby mode function (active low) keeps the current consumption down to  $1\ \mu\text{A}$  typical.

The TS2007FC is available in a 9-bump flip-chip lead-free package.

# Contents

- 1 Absolute maximum ratings and operating conditions ..... 3**
- 2 Application information ..... 5**
- 3 Electrical characteristics ..... 6**
  - 3.1 Electrical characteristics tables ..... 6
  - 3.2 Electrical characteristic curves ..... 11
- 4 Application information ..... 20**
  - 4.1 Differential configuration principle ..... 20
  - 4.2 Gain settings ..... 20
  - 4.3 Common mode feedback loop limitations ..... 20
  - 4.4 Low frequency response ..... 20
  - 4.5 Circuit decoupling ..... 21
  - 4.6 Wake-up time ( $t_{wu}$ ) ..... 21
  - 4.7 Shutdown time ..... 22
  - 4.8 Consumption in shutdown mode ..... 22
  - 4.9 Single-ended input configuration ..... 22
  - 4.10 Output filter considerations ..... 23
  - 4.11 Short-circuit protection ..... 24
  - 4.12 Thermal shutdown ..... 24
- 5 Package information ..... 25**
- 6 Ordering information ..... 27**
- 7 Revision history ..... 27**

# 1 Absolute maximum ratings and operating conditions

**Table 1. Absolute maximum ratings (AMR)**

Symbol	Parameter	Value	Unit
$V_{CC}$	Supply voltage <sup>(1)</sup>	6	V
$V_{in}$	Input voltage <sup>(2)</sup>	GND to $V_{CC}$	V
$T_{oper}$	Operating free-air temperature range	-40 to + 85	°C
$T_{stg}$	Storage temperature	-65 to +150	°C
$T_j$	Maximum junction temperature	150	°C
$R_{thja}$	Thermal resistance junction to ambient <sup>(3)</sup>	200	°C/W
$P_d$	Power dissipation	Internally limited <sup>(4)</sup>	
ESD	Human body model <sup>(5)</sup>	2	kV
	Machine model <sup>(6)</sup>	200	V
Latch-up	Latch-up immunity	Class A = 200	mA
	Lead temperature (soldering, 10 sec)	260	°C
	Output short circuit protection <sup>(7)</sup>		
$R_L$	Minimum load resistor	3.2	$\Omega$

1. All voltage values are measured with respect to the ground pin.
2. The magnitude of input signal must never exceed  $V_{CC} + 0.3\text{ V} / \text{GND} - 0.3\text{ V}$
3. The device is protected in case of over temperature by a thermal shutdown active @ 150° C.
4. Exceeding the power derating curves during a long period provokes abnormal operating conditions.
5. Human body model: 100 pF discharged through a 1.5 k $\Omega$  resistor between two pins of the device, done for all couples of pin combinations with other pins floating.
6. Machine model: a 200 pF cap is charged to the specified voltage, then discharged directly between two pins of the device with no external series resistor (internal resistor < 5  $\Omega$ ), done for all couples of pin combinations with other pins floating.
7. Implemented short-circuit protection protects the amplifier against damage by short-circuit between positive and negative outputs and between outputs and ground.

**Table 2. Operating conditions**

Symbol	Parameter	Value	Unit
$V_{CC}$	Supply voltage	2.4 to 5.5	V
$V_{in}$	Input voltage range	GND to $V_{CC}$	V
$V_{icm}$	Input common mode voltage range <sup>(1)</sup>	GND + 0.15 V to $V_{CC} - 0.7$ V	V
$V_{STBY}$	Standby voltage input: <sup>(2)</sup> Device ON Device OFF	$1.4 \leq V_{STBY} \leq V_{CC}$ $GND \leq V_{STBY} \leq 0.4$ <sup>(3)</sup>	V
$V_{GS}$	Gain select input voltage: <sup>(4)</sup> Gain = 6 dB Gain = 12 dB	$1.4 \leq V_{GS} \leq V_{CC}$ $GND \leq V_{GS} \leq 0.4$	V
$R_L$	Load resistor	$\geq 4$	$\Omega$
$R_{thja}$	Thermal resistance junction to ambient <sup>(5)</sup>	90	$^{\circ}\text{C}/\text{W}$

1.  $|V_{ool}| \leq 35$  mV max with both differential gains.
2. Without any signal on  $V_{STBY}$ , the device is in standby (internal 300 k $\Omega$  pull down resistor).
3. Minimum current consumption is obtained when  $V_{STBY} = \text{GND}$ .
4. Without any signal on GS pin, the device is in a 6 dB gain configuration (internal 300 k $\Omega$  pull up resistor).
5. With mounted on 4-layer PCB.

## 2 Application information

**Table 3. External component description**

Components	Functional description
$C_s$	Supply capacitor that provides power supply filtering.
$C_{in}$	Input coupling capacitors (optional) that block the DC voltage at the amplifier input terminal. These capacitors also form a high-pass filter with $Z_{in}$ ( $F_c = 1 / (2 \times \pi \times Z_{in} \times C_{in})$ ).

**Table 4. Pin description**

Pin name	Pin description
IN+	Positive differential input
VCC	Power supply
IN-	Negative differential input
GS	Gain select input
STDBY	Standby pin (active low)
GND	Ground
OUT+	Positive differential output
OUT-	Negative differential output

**Figure 1. Typical application**

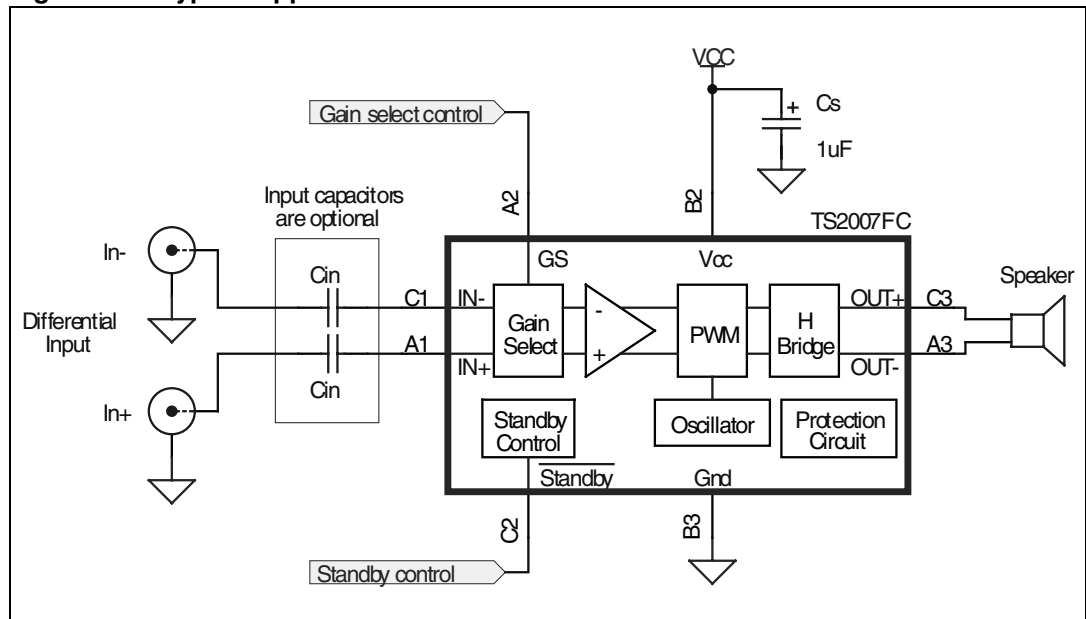

Note: See [Section 4.10: Output filter considerations](#) on page 23.

### 3 Electrical characteristics

#### 3.1 Electrical characteristics tables

**Table 5.**  $V_{CC} = +5\text{ V}$ ,  $GND = 0\text{ V}$ ,  $V_{IC} = 2.5\text{ V}$ ,  $T_{amb} = 25^\circ\text{C}$  (unless otherwise specified)

Symbol	Parameter	Min.	Typ.	Max.	Unit
$I_{CC}$	Supply current. No input signal, no load		2.5	4	mA
$I_{CC-STBY}$	Standby current <sup>(1)</sup> . No input signal, $V_{STBY} = GND$ .		1	2	$\mu\text{A}$
$V_{oo}$	Output offset voltage. Floating inputs, $R_L = 8\ \Omega$			25	mV
$P_o$	Output power THD = 1% max, F = 1 kHz, $R_L = 4\ \Omega$ THD = 1% max, F = 1 kHz, $R_L = 8\ \Omega$ THD = 10% max, F = 1 kHz, $R_L = 4\ \Omega$ THD = 10% max, F = 1 kHz, $R_L = 8\ \Omega$		2.3 1.4 3 1.75		W
THD + N	Total harmonic distortion + noise $P_o = 900\text{ mW}_{RMS}$ , G = 6 dB, F = 1 kHz, $R_L = 8\ \Omega$		0.12		%
Efficiency	Efficiency $P_o = 2.3\text{ W}_{rms}$ , $R_L = 4\ \Omega$ (with LC output filter) $P_o = 1.4\text{ W}_{rms}$ , $R_L = 8\ \Omega$ (with LC output filter)		86 92		%
PSRR	Power supply rejection ratio with inputs grounded, $C_{IN} = 1\ \mu\text{F}$ <sup>(2)</sup> F = 217 Hz, $R_L = 8\ \Omega$ , Gain = 6 dB, $V_{ripple} = 200\text{ mV}_{pp}$ F = 217 Hz, $R_L = 8\ \Omega$ , Gain = 12 dB, $V_{ripple} = 200\text{ mV}_{pp}$		68 65		dB
CMRR	Common mode rejection ratio $C_{in}=1\ \mu\text{F}$ , $R_L = 8\ \Omega$ 20 Hz < F < 20 kHz, Gain = 6 dB, $\Delta V_{ICM} = 200\text{ mV}_{pp}$		60		dB
Gain	Gain value, $G_S = 0\text{ V}$ Gain value, $G_S = V_{CC}$	11.5 5.5	12 6	12.5 6.5	dB
$Z_{in}$	Single ended input impedance <sup>(3)</sup>	68	75	82	k $\Omega$
$F_{PWM}$	Pulse width modulator base frequency	190	280	370	kHz
SNR	Signal-to-noise ratio (A-weighting), F = 1 kHz, $P_o = 1.9\text{ W}$ G = 6 dB, $R_L = 4\ \Omega$ (with LC output filter)		93		dB
$t_{WU}$	Wake-up time		1	3	ms
$t_{STBY}$	Standby time		1		ms
$V_N$	Output voltage noise, F = 20 Hz to 20 kHz, $R_L = 4\ \Omega$ Unweighted (filterless, G = 6 dB) A-weighted (filterless, G = 6 dB) Unweighted (with LC output filter, G = 6 dB) A-weighted (with LC output filter, G = 6 dB) Unweighted (filterless, G = 12 dB) A-weighted (filterless, G = 12 dB) Unweighted (with LC output filter, G = 12 dB) A-weighted (with LC output filter, G = 12 dB)		87 60 83 58 106 77 101 75		$\mu\text{V}_{rms}$

- Standby mode is active when  $V_{STBY}$  is tied to GND.
- Dynamic measurement -  $20 \cdot \log(\text{rms}(V_{out})/\text{rms}(V_{ripple}))$ .  $V_{ripple}$  is the superimposed sinus signal to  $V_{CC}$  @ F = 217 Hz.
- Independent of gain configuration (6 or 12 dB) and between IN+ or IN- and GND.

**Table 6.**  $V_{CC} = +4.2\text{ V}$ ,  $GND = 0\text{ V}$ ,  $V_{IC} = 2.1\text{ V}$ ,  $T_{amb} = 25^\circ\text{C}$  (unless otherwise specified)

Symbol	Parameter	Min.	Typ.	Max.	Unit
$I_{CC}$	Supply current No input signal, no load		2	3.3	mA
$I_{CC-STBY}$	Standby current <sup>(1)</sup> No input signal, $V_{STBY} = GND$		0.85	2	$\mu\text{A}$
$V_{oo}$	Output offset voltage Floating inputs, $R_L = 8\ \Omega$			25	mV
$P_o$	Output power THD = 1% max, F = 1 kHz, $R_L = 4\ \Omega$ THD = 1% max, F = 1 kHz, $R_L = 8\ \Omega$ THD = 10% max, F = 1 kHz, $R_L = 4\ \Omega$ THD = 10% max, F = 1 kHz, $R_L = 8\ \Omega$		1.6 0.95 2 1.2		W
THD + N	Total harmonic distortion + noise $P_o = 600\text{ mW}_{rms}$ , G = 6 dB, F = 1 kHz, $R_L = 8\ \Omega$		0.09		%
Efficiency	Efficiency $P_o = 1.6\text{ W}_{rms}$ , $R_L = 4\ \Omega$ (with LC output filter) $P_o = 0.95\text{ W}_{rms}$ , $R_L = 8\ \Omega$ (with LC output filter)		86 92		%
PSRR	Power supply rejection ratio with inputs grounded, $C_{in} = 1\ \mu\text{F}$ <sup>(2)</sup> F = 217 Hz, $R_L = 8\ \Omega$ , Gain = 6 dB, $V_{ripple} = 200\text{ mV}_{pp}$ F = 217 Hz, $R_L = 8\ \Omega$ , Gain = 12 dB, $V_{ripple} = 200\text{ mV}_{pp}$		68 65		dB
CMRR	Common mode rejection ratio $C_{in} = 1\ \mu\text{F}$ , $R_L = 8\ \Omega$ , 20 Hz < F < 20 kHz, Gain = 6 dB, $\Delta V_{ICM} = 200\text{ mV}_{pp}$		60		dB
Gain	Gain value $G_S = 0\text{ V}$ $G_S = V_{CC}$	11.5 5.5	12 6	12.5 6.5	dB
$Z_{IN}$	Single ended input impedance <sup>(3)</sup>	68	75	82	k $\Omega$
$F_{PWM}$	Pulse width modulator base frequency	190	280	370	kHz
SNR	Signal-to-noise ratio (A-weighting), F=1 kHz, $P_o = 1.3\text{ W}$ G = 6 dB, $R_L = 4\ \Omega$ (with LC output filter)		92		dB
$t_{WU}$	Wake-up time		1	3	ms
$t_{STBY}$	Standby time		1		ms
$V_N$	Output voltage noise, F = 20 Hz to 20 kHz, $R_L = 4\ \Omega$ Unweighted (filterless, G = 6 dB) A-weighted (filterless, G = 6 dB) Unweighted (with LC output filter, G = 6 dB) A-weighted (with LC output filter, G = 6 dB) Unweighted (filterless, G = 12 dB) A-weighted (filterless, G = 12 dB) Unweighted (with LC output filter, G = 12 dB) A-weighted (with LC output filter, G = 12 dB)		86 59 82 57 105 74 100 74		$\mu\text{V}_{rms}$

1. Standby mode is active when  $V_{STBY}$  is tied to GND.

2. Dynamic measurements -  $20 \cdot \log(\text{rms}(V_{out})/\text{rms}(V_{ripple}))$ .  $V_{ripple}$  is the superimposed sinus signal to  $V_{CC}$  @ F = 217 Hz.

3. Independent of Gain configuration (6 or 12 dB) and between IN+ or IN- and GND.

**Table 7.  $V_{CC} = +3.6\text{ V}$ ,  $GND = 0\text{ V}$ ,  $V_{IC} = 1.8\text{ V}$ ,  $T_{amb} = 25^\circ\text{C}$  (unless otherwise specified)**

Symbol	Parameter	Min.	Typ.	Max.	Unit
$I_{CC}$	Supply current No input signal, no load		1.7	3.1	mA
$I_{CC-STBY}$	Standby current <sup>(1)</sup> No input signal, $V_{STBY} = GND$		0.75	2	$\mu\text{A}$
$V_{oo}$	Output offset voltage Floating inputs, $R_L = 8\ \Omega$			25	mV
$P_o$	Output power THD = 1% max, $F = 1\text{ kHz}$ , $R_L = 4\ \Omega$ THD = 1% max, $F = 1\text{ kHz}$ , $R_L = 8\ \Omega$ THD = 10% max, $F = 1\text{ kHz}$ , $R_L = 4\ \Omega$ THD = 10% max, $F = 1\text{ kHz}$ , $R_L = 8\ \Omega$		1.2 0.7 1.55 0.9		W
THD + N	Total harmonic distortion + noise $P_o = 400\text{ mW}_{rms}$ , $G = 6\text{ dB}$ , $F = 1\text{ kHz}$ , $R_L = 8\ \Omega$		0.06		%
Efficiency	Efficiency $P_o = 1.18\text{ W}_{rms}$ , $R_L = 4\ \Omega$ (with LC output filter) $P_o = 0.7\text{ W}_{rms}$ , $R_L = 8\ \Omega$ (with LC output filter)		86 92		%
PSRR	Power supply rejection ratio with inputs grounded, $C_{in} = 1\ \mu\text{F}$ <sup>(2)</sup> $F = 217\text{ Hz}$ , $R_L = 8\ \Omega$ , $\text{Gain} = 6\text{ dB}$ , $V_{ripple} = 200\text{ mV}_{pp}$ $F = 217\text{ Hz}$ , $R_L = 8\ \Omega$ , $\text{Gain} = 12\text{ dB}$ , $V_{ripple} = 200\text{ mV}_{pp}$		68 65		dB
CMRR	Common mode rejection ratio $C_{in} = 1\ \mu\text{F}$ , $R_L = 8\ \Omega$ , $20\text{ Hz} < F < 20\text{ kHz}$ , $\text{Gain} = 6\text{ dB}$ , $\Delta V_{ICM} = 200\text{ mV}_{pp}$		60		dB
Gain	Gain value $G_S = 0\text{ V}$ $G_S = V_{CC}$	11.5 5.5	12 6	12.5 6.5	dB
$Z_{in}$	Single ended input impedance <sup>(3)</sup>	68	75	82	k $\Omega$
$F_{PWM}$	Pulse width modulator base frequency	190	280	370	kHz
SNR	Signal-to-noise ratio (A-weighting), $F=1\text{ kHz}$ , $P_o = 0.9\text{ W}$ $G = 6\text{ dB}$ , $R_L = 4\ \Omega$ (with LC output filter)		90		dB
$t_{WU}$	Wake-up time		1	3	ms
$t_{STBY}$	Standby time		1		ms
$V_N$	Output voltage noise, $F = 20\text{ Hz to } 20\text{ kHz}$ , $R_L = 4\ \Omega$ Unweighted (filterless, $G = 6\text{ dB}$ ) A-weighted (filterless, $G = 6\text{ dB}$ ) Unweighted (with LC output filter, $G = 6\text{ dB}$ ) A-weighted (with LC output filter, $G = 6\text{ dB}$ ) Unweighted (filterless, $G = 12\text{ dB}$ ) A-weighted (filterless, $G = 12\text{ dB}$ ) Unweighted (with LC output filter, $G = 12\text{ dB}$ ) A-weighted (with LC output filter, $G = 12\text{ dB}$ )		84 58 79 56 104 75 99 72		$\mu\text{V}_{RMS}$

- Standby mode is active when  $V_{STBY}$  is tied to GND.
- Dynamic measurements -  $20 \cdot \log(\text{rms}(V_{out})/\text{rms}(V_{ripple}))$ .  $V_{ripple}$  is the superimposed sinus signal to  $V_{CC}$  @  $F=217\text{ Hz}$ .
- Independent of gain configuration (6 or 12 dB) and between IN+ or IN- and GND.

**Table 8.**  $V_{CC} = +3.0\text{ V}$ ,  $GND = 0\text{ V}$ ,  $V_{ic} = 1.5\text{ V}$ ,  $T_{amb} = 25^\circ\text{C}$  (unless otherwise specified)

Symbol	Parameter	Min.	Typ.	Max.	Unit
$I_{CC}$	Supply current No input signal, no load		1.5	2.9	mA
$I_{CC-STBY}$	Standby current <sup>(1)</sup> No input signal, $V_{STBY} = GND$		0.6	2	$\mu\text{A}$
$V_{oo}$	Output offset voltage Floating inputs, $R_L = 8\ \Omega$			25	mV
$P_o$	Output power THD = 1% max, F = 1 kHz, $R_L = 4\ \Omega$ THD = 1% max, F = 1 kHz, $R_L = 8\ \Omega$ THD = 10% max, F = 1 kHz, $R_L = 4\ \Omega$ THD = 10% max, F = 1 kHz, $R_L = 8\ \Omega$		0.75 0.5 1 0.6		W
THD + N	Total harmonic distortion + noise $P_o = 300\text{ mW}_{RMS}$ , G = 6 dB, F = 1 kHz, $R_L = 8\ \Omega$		0.04		%
Efficiency	Efficiency $P_o = 0.8\text{ W}_{rms}$ , $R_L = 4\ \Omega$ (with LC output filter) $P_o = 0.5\text{ W}_{rms}$ , $R_L = 8\ \Omega$ (with LC output filter)		85 91		%
PSRR	Power supply rejection ratio with inputs grounded, $C_{in} = 1\ \mu\text{F}$ <sup>(2)</sup> F = 217 Hz, $R_L = 8\ \Omega$ , Gain = 6 dB, $V_{ripple} = 200\text{ mV}_{pp}$ F = 217 Hz, $R_L = 8\ \Omega$ , Gain = 12 dB, $V_{ripple} = 200\text{ mV}_{pp}$		68 65		dB
CMRR	Common mode rejection ratio $C_{in} = 1\ \mu\text{F}$ , $R_L = 8\ \Omega$ , 20 Hz < F < 20 kHz, Gain = 6 dB, $\Delta V_{ICM} = 200\text{ mV}_{pp}$		60		dB
Gain	Gain value $G_S = 0\text{ V}$ $G_S = V_{CC}$	11.5 5.5	12 6	12.5 6.5	dB
$Z_{in}$	Single ended input impedance <sup>(3)</sup>	68	75	82	k $\Omega$
$F_{PWM}$	Pulse width modulator base frequency	190	280	370	kHz
SNR	Signal-to-noise ratio (A-weighting), F=1 kHz, $P_o = 0.6\text{ W}$ G = 6 dB, $R_L = 4\ \Omega$ (with LC output filter)		89		dB
$t_{WU}$	Wake-up time		1	3	ms
$t_{STBY}$	Standby time		1		ms
$V_N$	Output voltage noise, F = 20 Hz to 20 kHz, $R_L = 4\ \Omega$ Unweighted (filterless, G = 6 dB) A-weighted (filterless, G = 6 dB) Unweighted (with LC output filter, G = 6 dB) A-weighted (with LC output filter, G = 6 dB) Unweighted (filterless, G = 12 dB) A-weighted (filterless, G = 12 dB) Unweighted (with LC output filter, G = 12 dB) A-weighted (with LC output filter, G = 12 dB)		82 57 78 55 103 74 99 71		$\mu\text{V}_{RMS}$

- Standby mode is active when  $V_{STBY}$  is tied to GND.
- Dynamic measurements -  $20 \cdot \log(\text{rms}(V_{out})/\text{rms}(V_{ripple}))$ .  $V_{ripple}$  is the superimposed sinus signal to  $V_{CC}$  @ F = 217 Hz.
- Independent of Gain configuration (6 or 12 dB) and between IN+ or IN- and GND.

**Table 9.**  $V_{CC} = +2.7\text{ V}$ ,  $GND = 0\text{ V}$ ,  $V_{ic} = 1.35\text{ V}$ ,  $T_{amb} = 25^\circ\text{C}$  (unless otherwise specified)

Symbol	Parameter	Min.	Typ.	Max.	Unit
$I_{CC}$	Supply current No input signal, no load		1.45	2.5	mA
$I_{CC-STBY}$	Standby current <sup>(1)</sup> No input signal, $V_{STBY} = GND$		0.5	2	$\mu\text{A}$
$V_{oo}$	Output offset voltage Floating inputs, $R_L = 8\ \Omega$			25	mV
$P_o$	Output power THD = 1% max, $F = 1\text{ kHz}$ , $R_L = 4\ \Omega$ THD = 1% max, $F = 1\text{ kHz}$ , $R_L = 8\ \Omega$ THD = 10% max, $F = 1\text{ kHz}$ , $R_L = 4\ \Omega$ THD = 10% max, $F = 1\text{ kHz}$ , $R_L = 8\ \Omega$		0.64 0.39 0.83 0.49		W
THD + N	Total harmonic distortion + noise $P_o = 250\text{ mW}_{rms}$ , $G = 6\text{ dB}$ , $F = 1\text{ kHz}$ , $R_L = 8\ \Omega$		0.03		%
Efficiency	Efficiency $P_o = 0.64\text{ W}_{rms}$ , $R_L = 4\ \Omega$ (with LC output filter) $P_o = 0.39\text{ W}_{rms}$ , $R_L = 8\ \Omega$ (with LC output filter)		84 91		%
PSRR	Power supply rejection ratio with inputs grounded, $C_{in} = 1\ \mu\text{F}$ <sup>(2)</sup> $F = 217\text{ Hz}$ , $R_L = 8\ \Omega$ , Gain = 6 dB, $V_{ripple} = 200\text{ mV}_{pp}$ $F = 217\text{ Hz}$ , $R_L = 8\ \Omega$ , Gain = 12 dB, $V_{ripple} = 200\text{ mV}_{pp}$		68 65		dB
CMRR	Common mode rejection ratio $C_{in} = 1\ \mu\text{F}$ , $R_L = 8\ \Omega$ , $20\text{ Hz} < F < 20\text{ kHz}$ , Gain = 6 dB, $\Delta V_{ICM} = 200\text{ mV}_{pp}$		60		dB
Gain	Gain value $G_S = 0\text{ V}$ $G_S = V_{CC}$	11.5 5.5	12 6	12.5 6.5	dB
$Z_{in}$	Single ended input impedance <sup>(3)</sup>	68	75	82	k $\Omega$
$F_{PWM}$	Pulse width modulator base frequency	190	280	370	kHz
SNR	Signal-to-noise ratio (A-weighting), $F = 1\text{ kHz}$ , $P_o = 0.5\text{ W}$ $G = 6\text{ dB}$ , $R_L = 4\ \Omega$ (with LC output filter)		88		dB
$t_{WU}$	Wake-up time		1	3	ms
$t_{STBY}$	Standby time		1		ms
$V_N$	Output voltage noise, $F = 20\text{ Hz}$ to $20\text{ kHz}$ , $R_L = 4\ \Omega$ Unweighted (filterless, $G = 6\text{ dB}$ ) A-weighted (filterless, $G = 6\text{ dB}$ ) Unweighted (with LC output filter, $G = 6\text{ dB}$ ) A-weighted (with LC output filter, $G = 6\text{ dB}$ ) Unweighted (filterless, $G = 12\text{ dB}$ ) A-weighted (filterless, $G = 12\text{ dB}$ ) Unweighted (with LC output filter, $G = 12\text{ dB}$ ) A-weighted (with LC output filter, $G = 12\text{ dB}$ )		82 56 77 55 100 73 98 70		$\mu\text{V}_{RMS}$

- Standby mode is active when  $V_{STBY}$  is tied to GND.
- Dynamic measurements -  $20 \cdot \log(\text{rms}(V_{out})/\text{rms}(V_{ripple}))$ .  $V_{ripple}$  is the superimposed sinus signal to  $V_{CC}$  @  $F = 217\text{ Hz}$ .
- Independent of Gain configuration (6 or 12 dB) and between IN+ or IN- and GND.

### 3.2 Electrical characteristic curves

The graphs shown in this section use the following abbreviations:

- $R_L + 15 \mu\text{H}$  or  $30 \mu\text{H}$  = pure resistor + very low series resistance inductor
- Filter = LC output filter ( $1 \mu\text{F} + 30 \mu\text{H}$  for  $4 \Omega$  and  $0.5 \mu\text{F} + 15 \mu\text{H}$  for  $8 \Omega$ )

All measurements are done with  $C_{S1} = 1 \mu\text{F}$  and  $C_{S2} = 100 \text{ nF}$  (Figure 2), except for the PSRR where  $C_{S1}$  is removed (Figure 3).

**Figure 2. Test diagram for measurements**

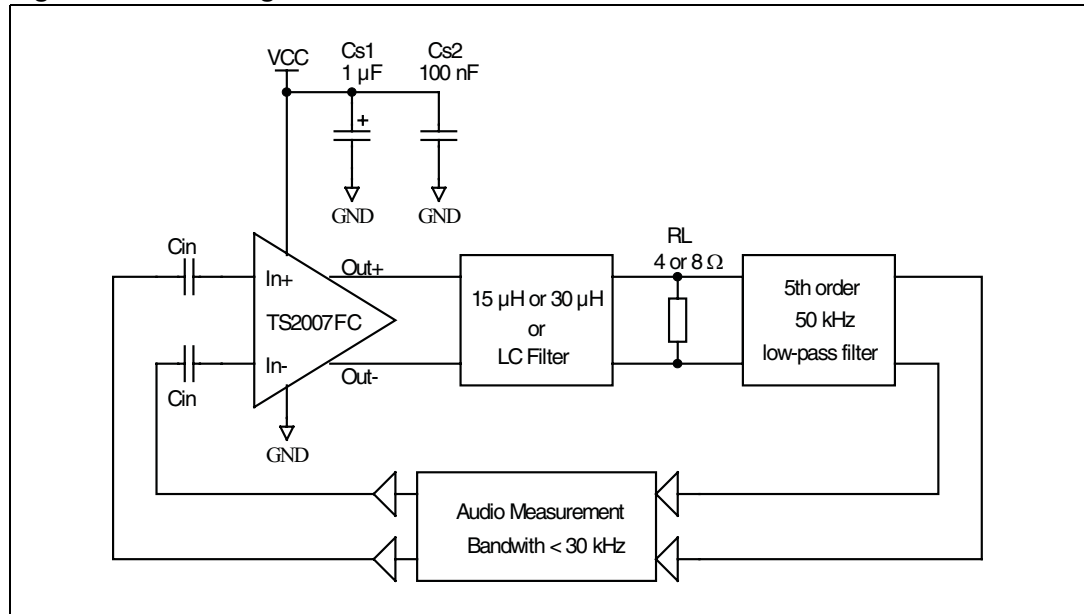

**Figure 3. Test diagram for PSRR measurements**

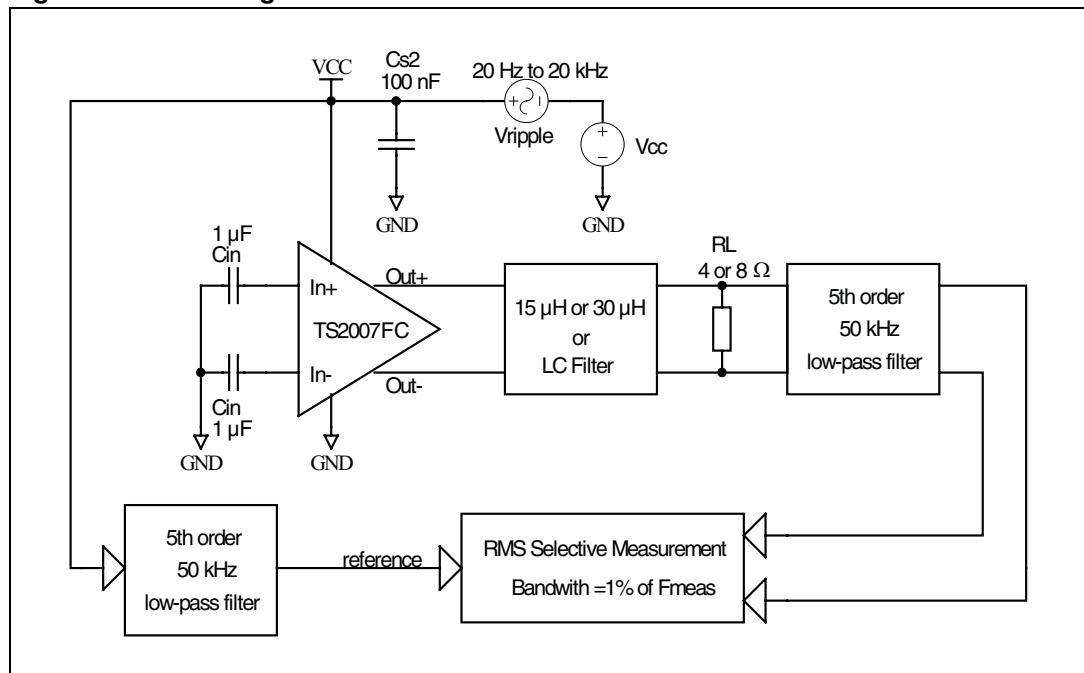

For quick reference, a list of the graphs shown in this section is provided in [Table 10](#).

**Table 10. Index of graphs**

Description	Figure
Current consumption vs. power supply voltage	<a href="#">Figure 4</a>
Standby current vs. power supply voltage	<a href="#">Figure 5</a>
Current consumption vs. standby voltage	<a href="#">Figure 6</a>
Efficiency vs. output power	<a href="#">Figure 7 to Figure 12</a>
Output power vs. power supply voltage	<a href="#">Figure 13, Figure 14</a>
THD+N vs. output power	<a href="#">Figure 15 to Figure 18</a>
THD+N vs. frequency	<a href="#">Figure 19 to Figure 28</a>
PSRR vs. frequency	<a href="#">Figure 29</a>
PSRR vs. common mode input voltage	<a href="#">Figure 30, Figure 31</a>
CMRR vs. frequency	<a href="#">Figure 32</a>
CMRR vs. common mode input voltage	<a href="#">Figure 33, Figure 34</a>
Gain vs. frequency	<a href="#">Figure 35, Figure 36</a>
Output offset vs. common mode input voltage	<a href="#">Figure 37 to Figure 39</a>
Power derating curves	<a href="#">Figure 40</a>
Startup and shutdown phase	<a href="#">Figure 41 to Figure 43</a>

Figure 4. Current consumption vs. power supply voltage

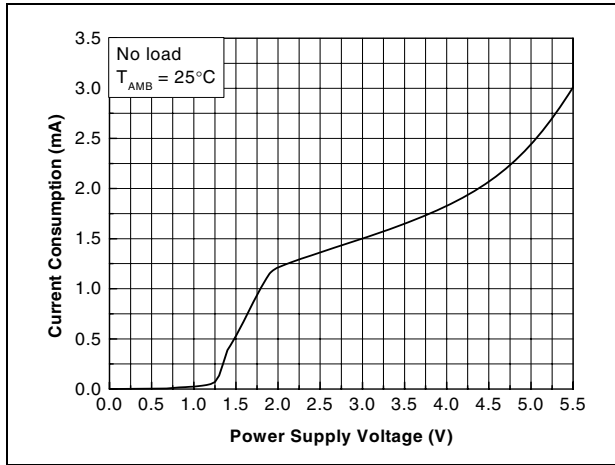

Figure 5. Standby current vs. power supply voltage

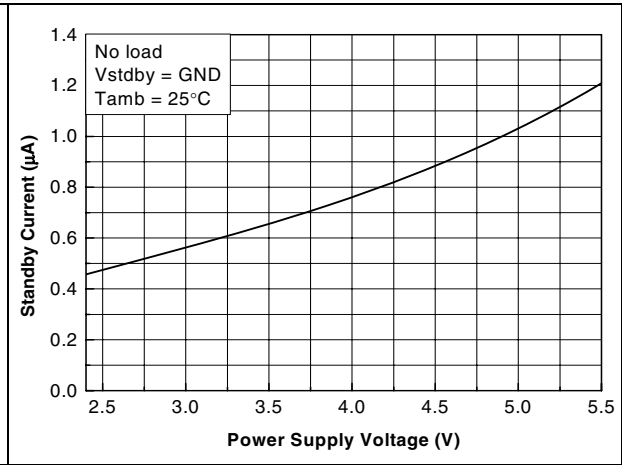

Figure 6. Current consumption vs. standby voltage

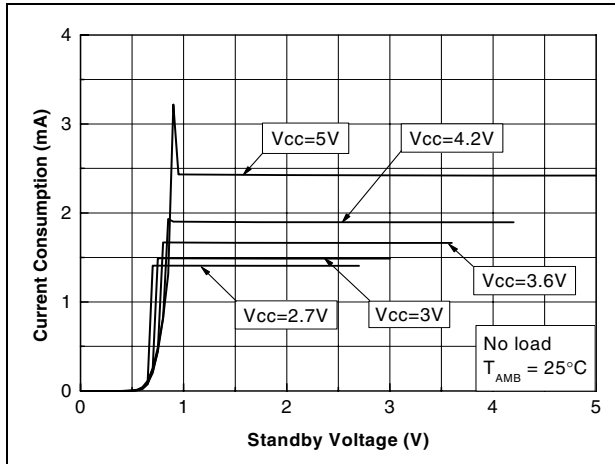

Figure 7. Efficiency vs. output power

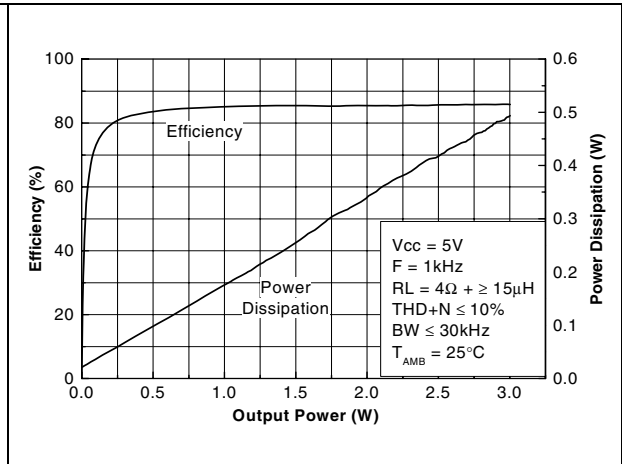

Figure 8. Efficiency vs. output power

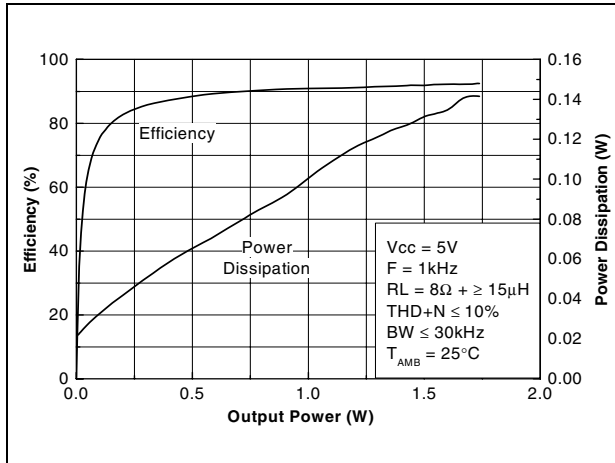

Figure 9. Efficiency vs. output power

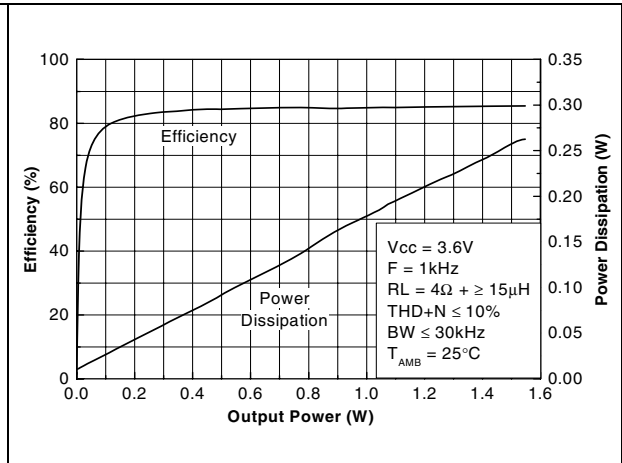

Figure 10. Efficiency vs. output power

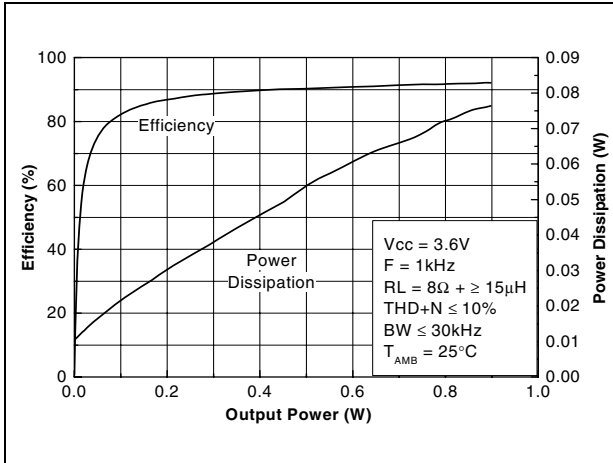

Figure 11. Efficiency vs. output power

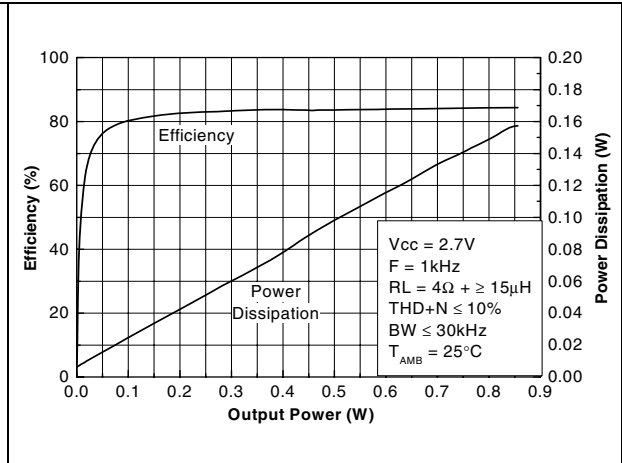

Figure 12. Efficiency vs. output power

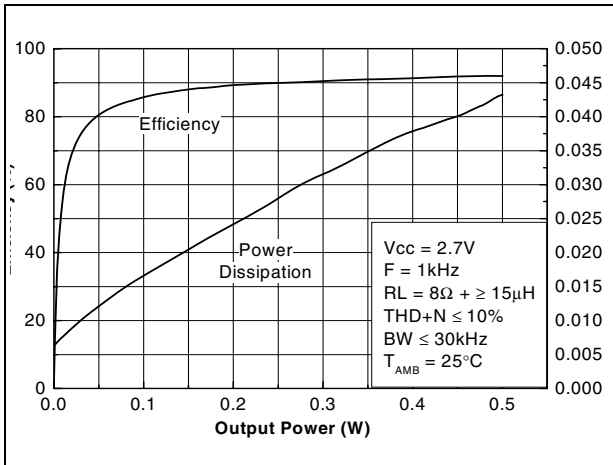

Figure 13. Output power vs. power supply voltage

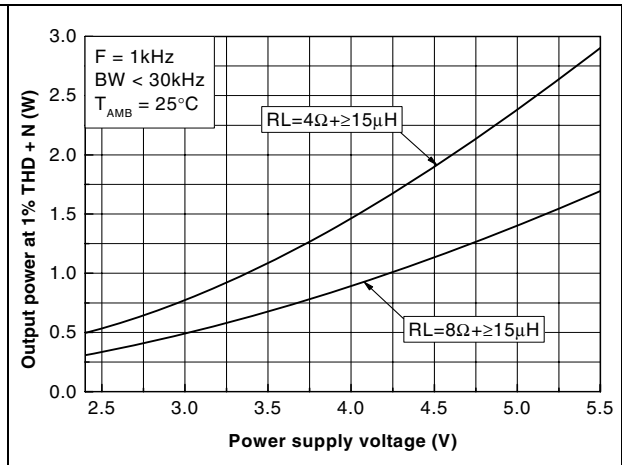

Figure 14. Output power vs. power supply voltage

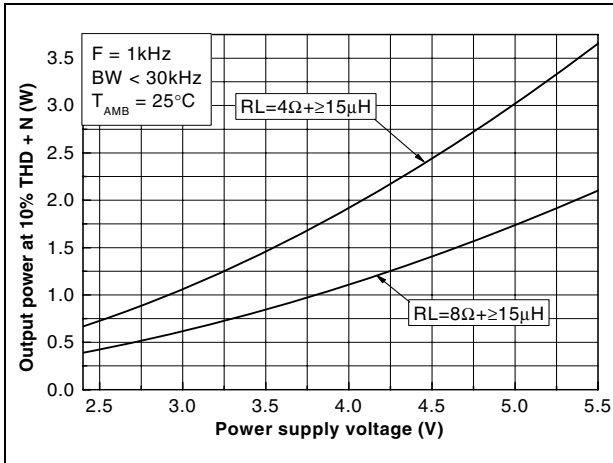

Figure 15. THD+N vs. output power

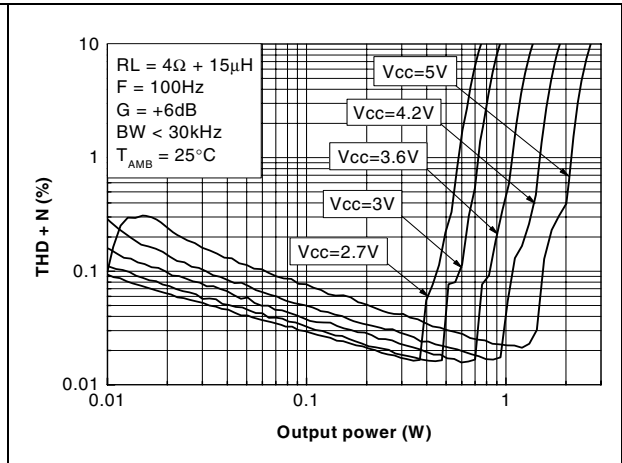

Figure 16. THD+N vs. output power

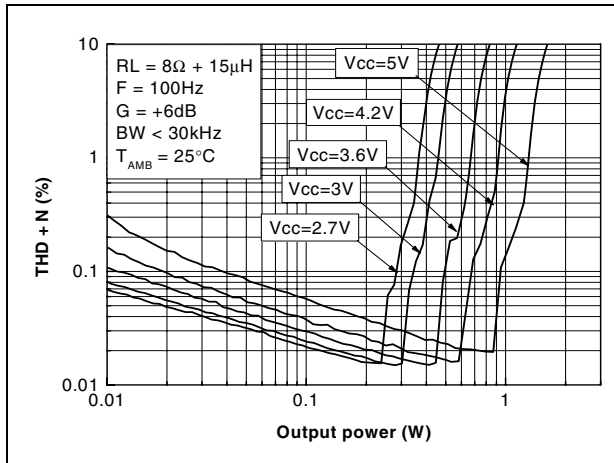

Figure 17. THD+N vs. output power

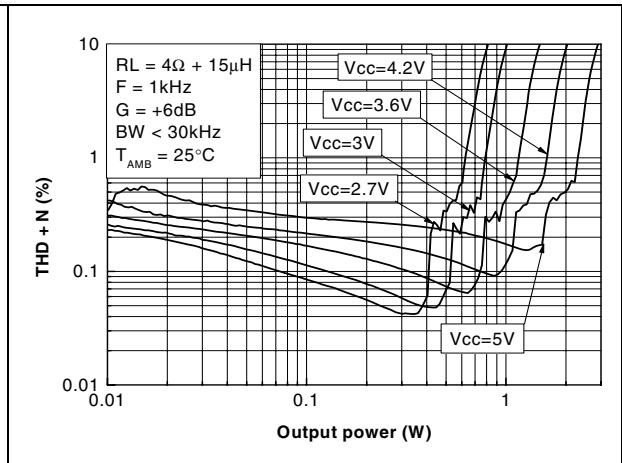

Figure 18. THD+N vs. output power

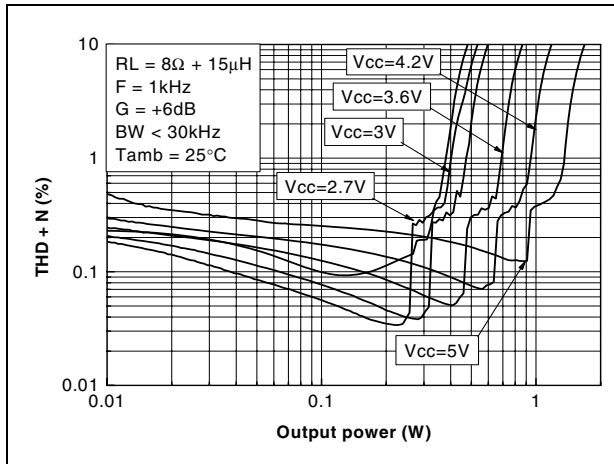

Figure 19. THD+N vs. frequency

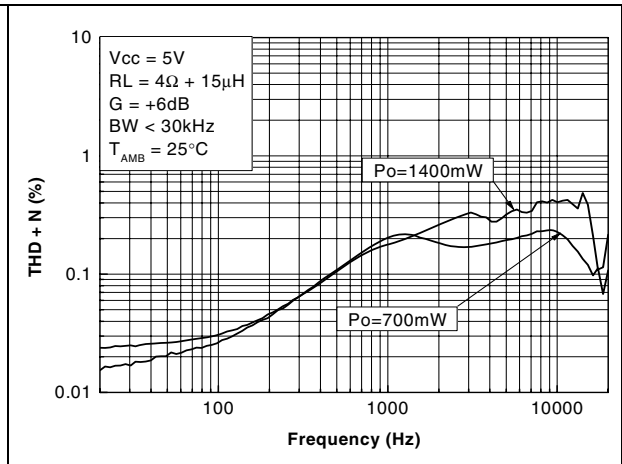

Figure 20. THD+N vs. frequency

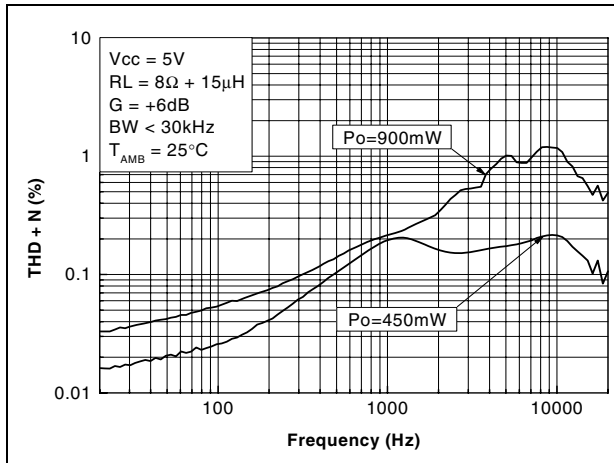

Figure 21. THD+N vs. frequency

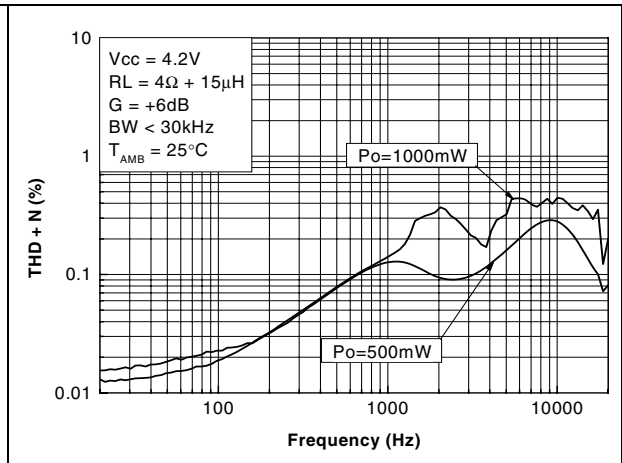

Figure 22. THD+N vs. frequency

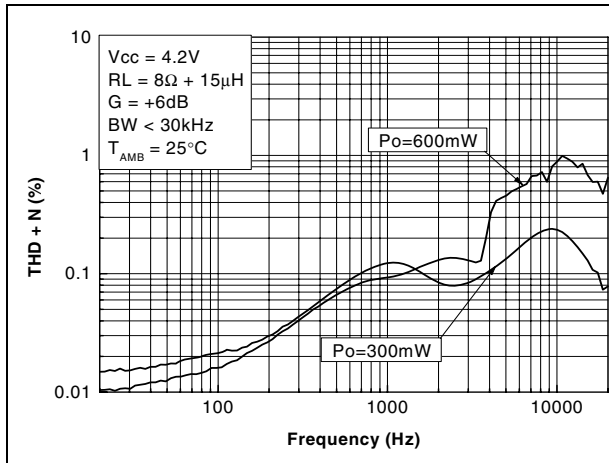

Figure 23. THD+N vs. frequency

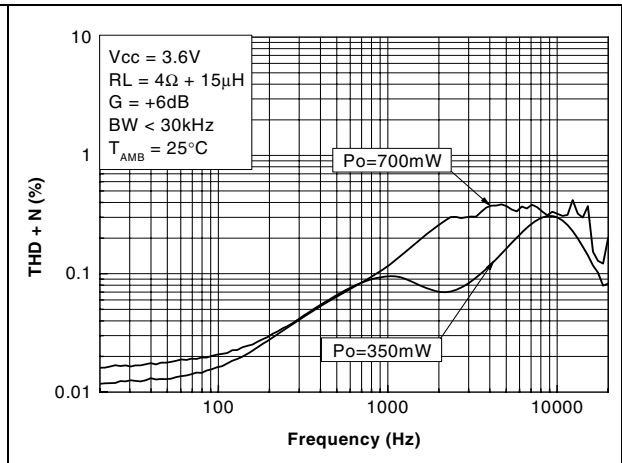

Figure 24. THD+N vs. frequency

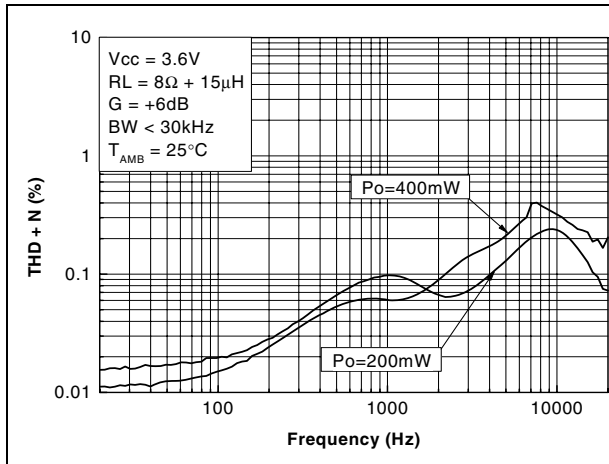

Figure 25. THD+N vs. frequency

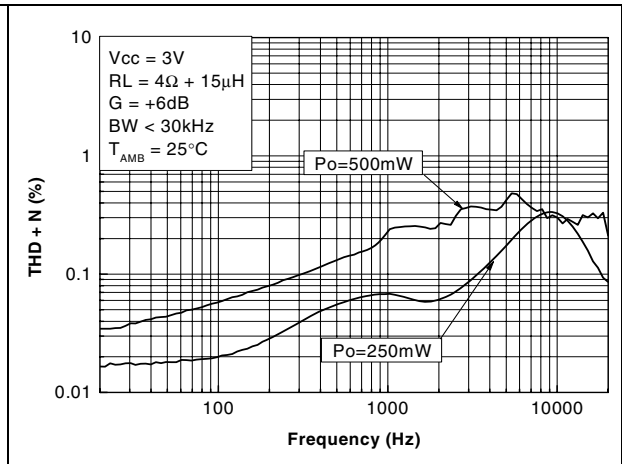

Figure 26. THD+N vs. frequency

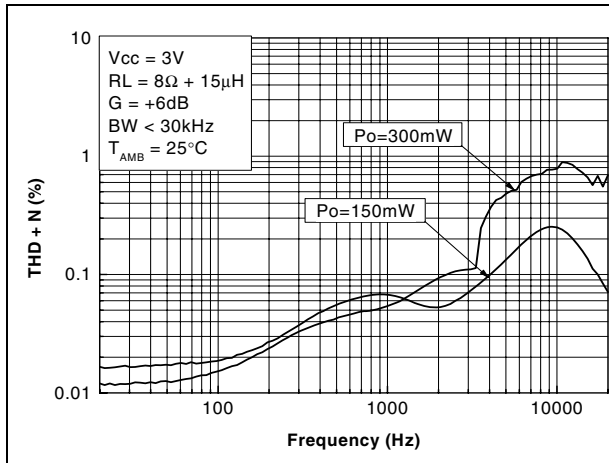

Figure 27. THD+N vs. frequency

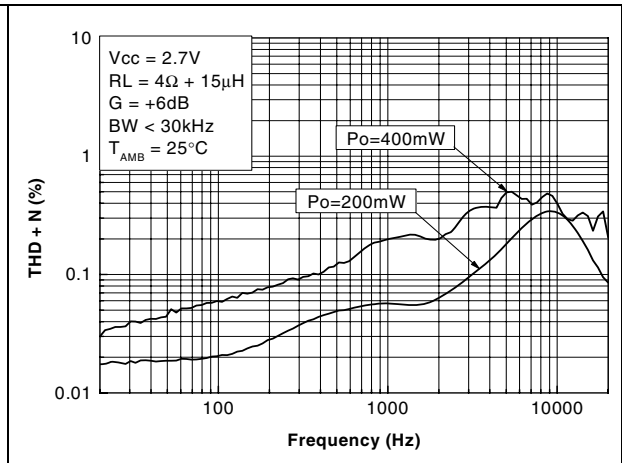

Figure 28. THD+N vs. frequency

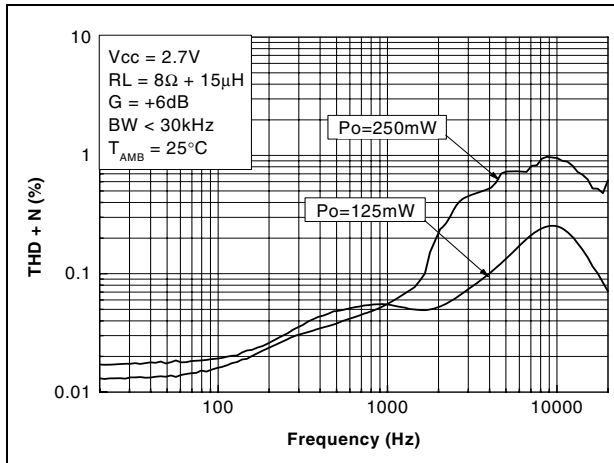

Figure 29. PSRR vs. frequency

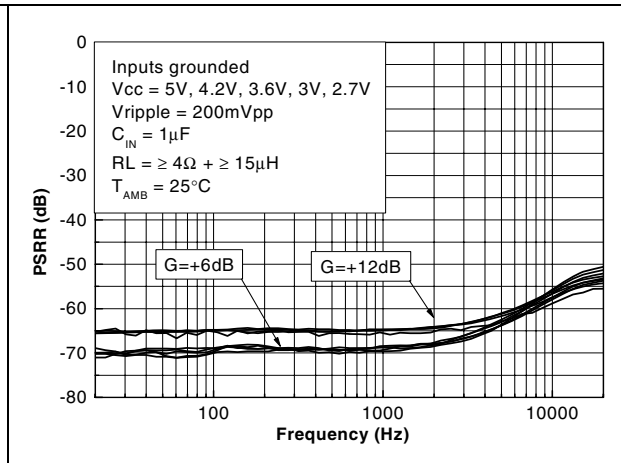

Figure 30. PSRR vs. common mode input voltage

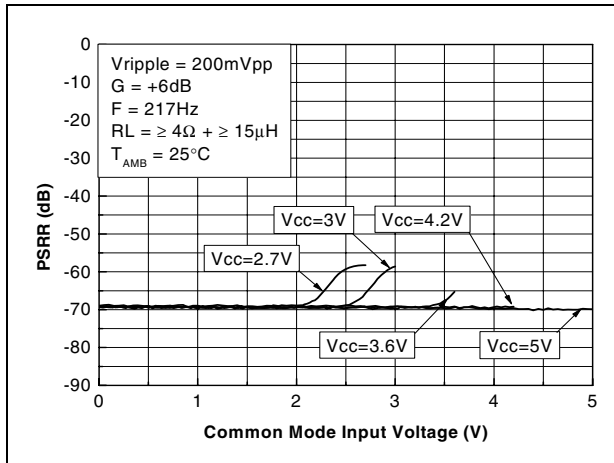

Figure 31. PSRR vs. common mode input voltage

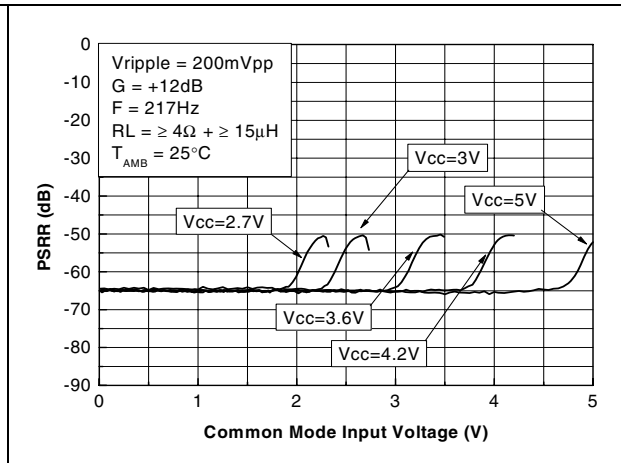

Figure 32. CMRR vs. frequency

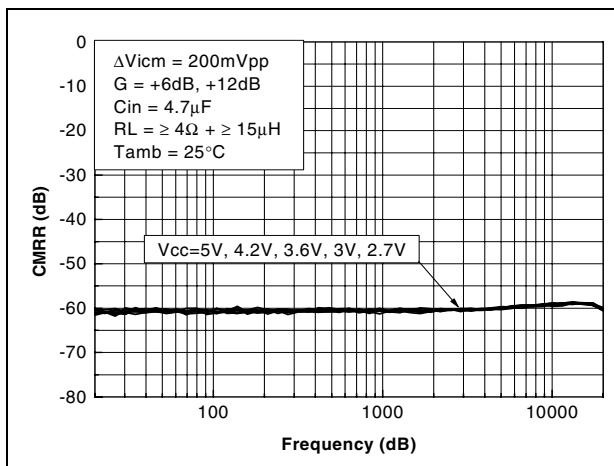

Figure 33. CMRR vs. common mode input voltage

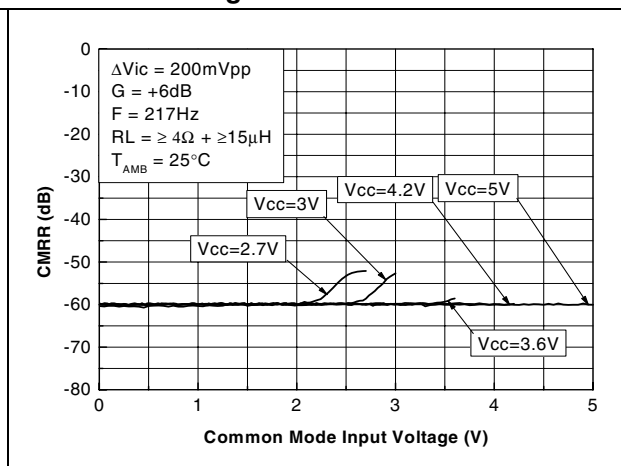

Figure 34. CMRR vs. common mode input voltage

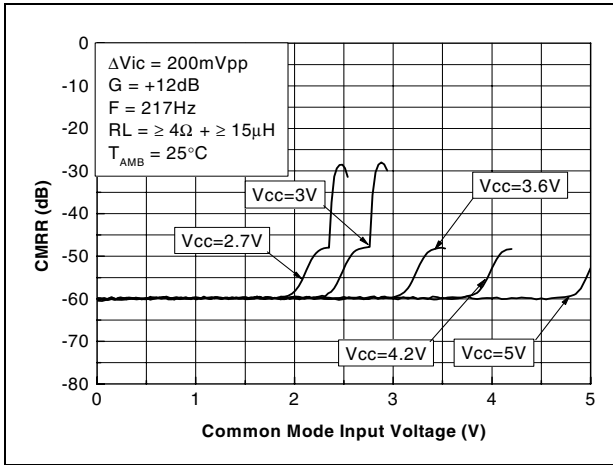

Figure 35. Gain vs. frequency

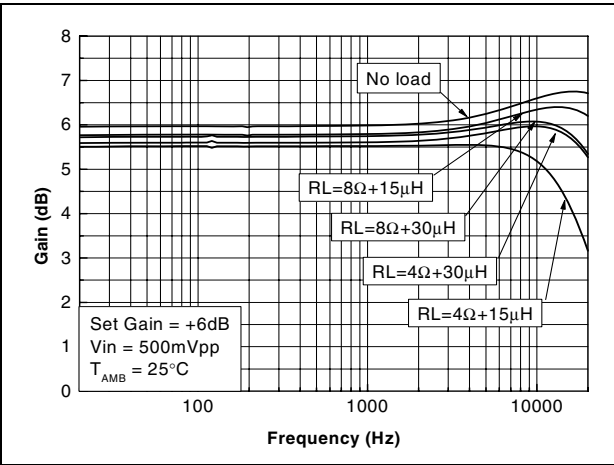

Figure 36. Gain vs. frequency

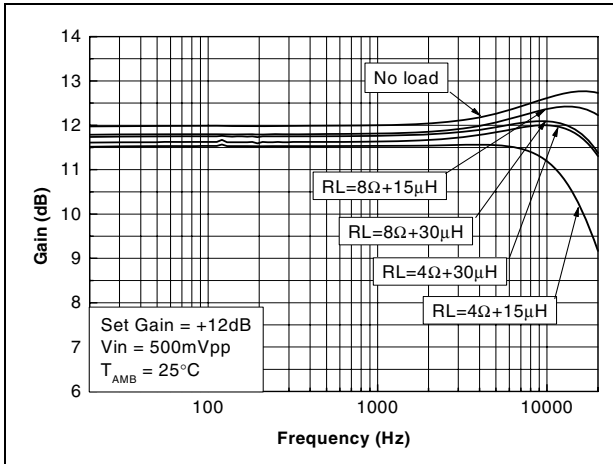

Figure 37. Output offset vs. common mode input voltage

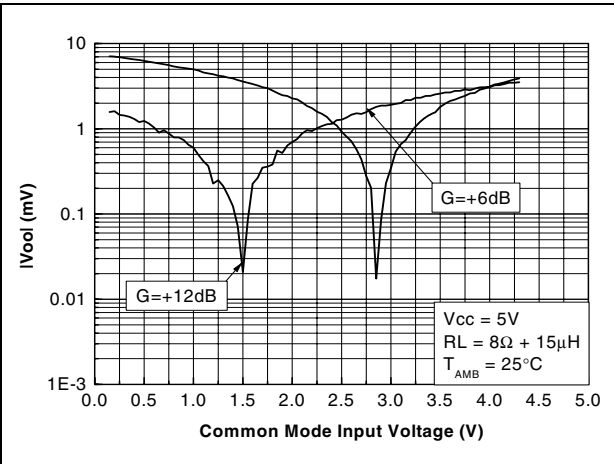

Figure 38. Output offset vs. common mode input voltage

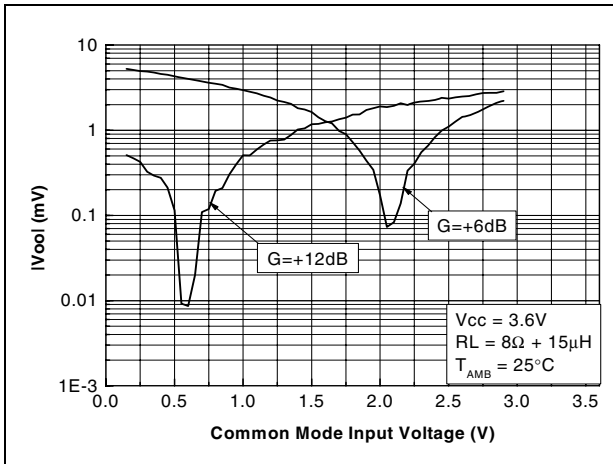

Figure 39. Output offset vs. common mode input voltage

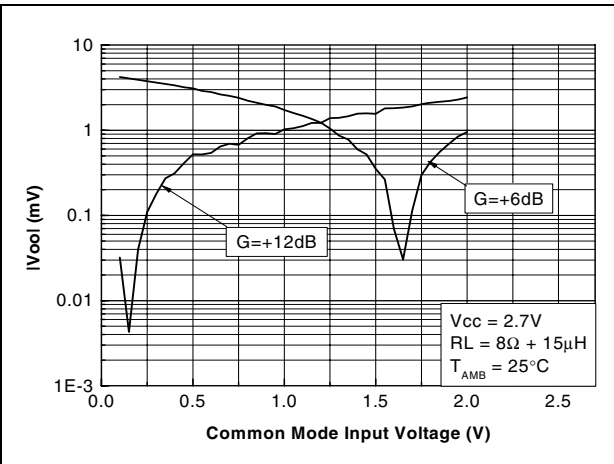

Figure 40. Power derating curves

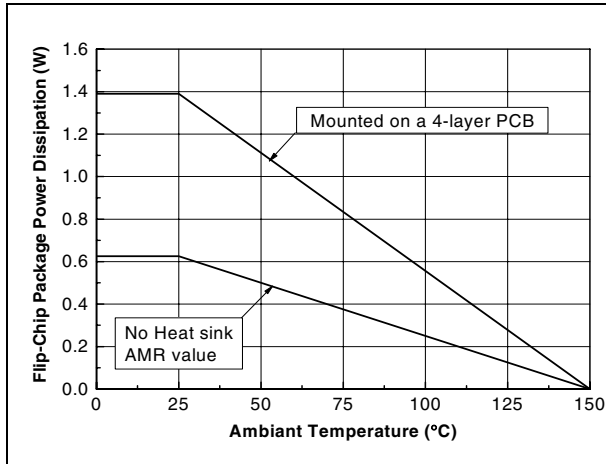

Figure 41. Startup and shutdown phase  
 $V_{CC}=5\text{ V}$ ,  $G=6\text{ dB}$ ,  $C_{in}=1\text{ }\mu\text{F}$ , inputs grounded

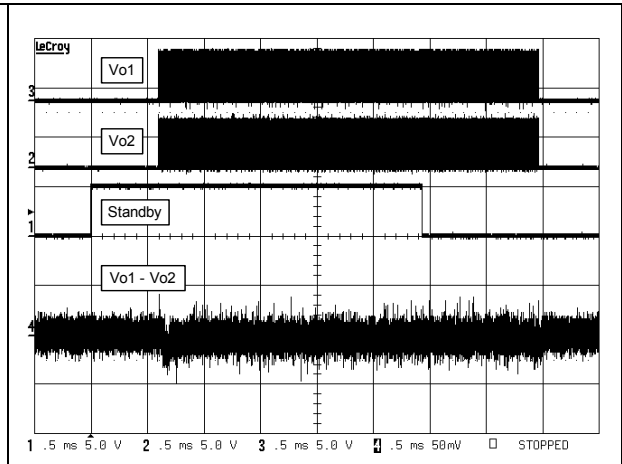

Figure 42. Startup and shutdown phase  
 $V_{CC}=5\text{ V}$ ,  $G=6\text{ dB}$ ,  $C_{in}=1\text{ }\mu\text{F}$ ,  
 $V_{in}=1\text{ V}_{pp}$ ,  $F=10\text{ kHz}$

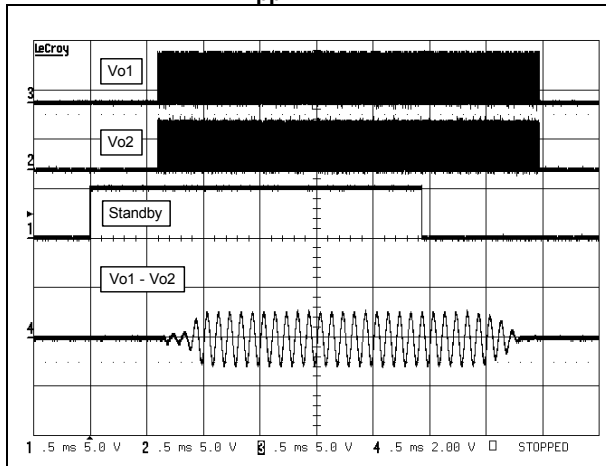
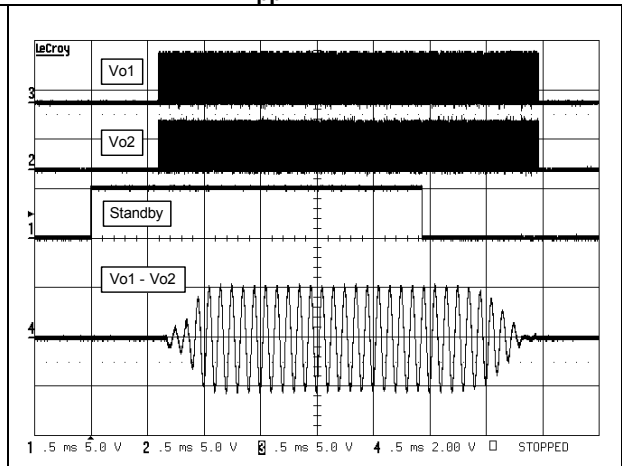

Figure 43. Startup and shutdown phase  
 $V_{CC}=5\text{ V}$ ,  $G=12\text{ dB}$ ,  $C_{in}=1\text{ }\mu\text{F}$ ,  
 $V_{in}=1\text{ V}_{pp}$ ,  $F=10\text{ kHz}$



## 4 Application information

### 4.1 Differential configuration principle

The TS2007FC is a monolithic fully-differential input/output class-D power amplifier. The TS2007FC includes a common-mode feedback loop that controls the output bias value to average it at  $V_{CC}/2$  in the range of DC common mode input voltage. This allows the device to always have a maximum output voltage swing, and by consequence, maximize the output power. In addition, as the load is connected differentially compared to a single-ended topology, the output is four times higher for the same power supply voltage.

A fully-differential amplifier has the following **advantages**:

- High PSRR (power supply rejection ratio)
- High CMRR (common mode noise rejection)
- Virtually zero pop without additional circuitry, giving a faster startup time than conventional single-ended input amplifier
- Easy interfacing with differential output audio DAC
- No input coupling capacitors required since there is a common mode feedback loop

### 4.2 Gain settings

In the flat region of the frequency-response curve (no input coupling capacitor or internal feedback loop + load effect), the differential gain can be set to either 6 or 12 dB depending on the logic level of the GS pin.

**Table 11. GS pin gains**

GS pin	Gain (dB)	Gain (V/V)
1	6 dB	2
0	12 dB	4

*Note:* Between the GS pin and  $V_{CC}$  there is an internal 300 k $\Omega$  resistor. When the pin is floating the gain is 6 dB. In standby mode, this internal resistor is disconnected (HiZ input).

### 4.3 Common mode feedback loop limitations

As explained previously, the common mode feedback loop allows the output DC bias voltage to be averaged at  $V_{CC}/2$  for any DC common mode bias input voltage.

Due to the  $V_{icm}$  limitation of the input stage (see [Table 2: Operating conditions](#)), the common mode feedback loop can fulfill its role only within the defined range.

### 4.4 Low frequency response

If a low frequency bandwidth limitation is required, it is possible to use input coupling capacitors. In the low frequency region, the input coupling capacitor  $C_{in}$  has a greater effect.  $C_{in}$  and the input impedance  $Z_{in}$  form a first-order high-pass filter with a -3 dB cutoff frequency (see [Table 5](#) to [Table 9](#)).

$$F_{CL} = \frac{1}{2 \cdot \pi \cdot Z_{in} \cdot C_{in}}$$

So, for a desired cutoff frequency  $F_{CL}$  we can calculate  $C_{in}$ :

$$C_{in} = \frac{1}{2 \cdot \pi \cdot Z_{in} \cdot F_{CL}}$$

with  $F_{CL}$  in Hz,  $Z_{in}$  in  $\Omega$  and  $C_{in}$  in F.

The input impedance  $Z_{in}$  is for the whole power supply voltage range, typically 75 k $\Omega$ . There is also a tolerance around the typical value (see [Table 5](#) to [Table 9](#)). With regard to the tolerance, you can also calculate tolerance of the  $F_{CL}$ :

- $F_{CLmax} = 1.103 \cdot F_{CL}$
- $F_{CLmin} = 0.915 \cdot F_{CL}$

## 4.5 Circuit decoupling

A power supply capacitor, referred to as  $C_S$ , is needed to correctly bypass the TS2007FC.

The TS2007FC has a typical switching frequency of 280 kHz and output fall and rise time of less than or equal to 5 ns. Due to these very fast transients, careful decoupling is mandatory.

A 1  $\mu$ F ceramic capacitor is enough, but it must be located very close to the TS2007FC in order to avoid any extra parasitic inductance created by a long track wire. Parasitic loop inductance, in relation with di/dt, introduces overvoltage that decreases the global efficiency of the device and may cause, if this parasitic inductance is too high, a TS2007FC breakdown. For filtering low frequency noise signals on the power line, it is recommended to use a capacitor  $C_S$  of at least 1  $\mu$ F.

In addition, even if a ceramic capacitor has an adequate high frequency ESR (equivalent series resistance) value, its current capability is also important. A 0603 size is a good compromise, particularly when a 4  $\Omega$  load is used.

Another important parameter is the rated voltage of the capacitor. A 1  $\mu$ F/6.3 V capacitor used at 5 V, loses about 50% of its value: with a power supply voltage of 5 V, the decoupling value, instead of 1  $\mu$ F, could be reduced to 0.5  $\mu$ F. As  $C_S$  has particular influence on the THD+N in the medium to high frequency region, this capacitor variation becomes decisive. In addition, less decoupling means higher overshoots which can be problematic if they reach the power supply AMR value (6 V).

## 4.6 Wake-up time ( $t_{wu}$ )

When the standby is released to set the device ON, there is a wait of 1 ms typically. The TS2007FC has an internal digital delay that mutes the outputs and releases them after this time in order to avoid any pop noise.

*Note:* The gain increases smoothly (see [Figure 42](#) and [Figure 43](#)) from the mute to the gain selected by the GS pin ([Section 4.2](#)).

### 4.7 Shutdown time

When the standby command is set to high, the time required to put the two output stages into high impedance and to put the internal circuitry in shutdown mode, is typically 1 ms. This time is used to decrease the gain and avoid any pop noise during shutdown.

*Note:* The gain decreases smoothly until the outputs are muted (see [Figure 42](#) and [Figure 43](#)).

### 4.8 Consumption in shutdown mode

Between the shutdown pin and GND there is an internal 300 kΩ resistor. This resistor forces the TS2007FC to be in shutdown when the shutdown input is left floating.

However, this resistor also introduces additional shutdown power consumption if the shutdown pin voltage does not equal 0 V. This extra current is provided by the device that drives the standby pin of the amplifier.

Referring to [Table 2: Operating conditions on page 4](#), with a 0.4 V shutdown voltage pin for example, you must add  $0.4\text{ V}/300\text{ k} = 1.3\text{ }\mu\text{A}$  in typical ( $0.4\text{ V}/273\text{ k} = 1.46\text{ }\mu\text{A}$  maximum) to the shutdown current specified in [Table 5](#) to [Table 9](#).

### 4.9 Single-ended input configuration

It is possible to use the TS2007FC in a single-ended input configuration. However, input coupling capacitors are needed in this configuration. The following schematic diagram shows a typical single-ended input application.

**Figure 44. Typical application for single-ended input configuration**

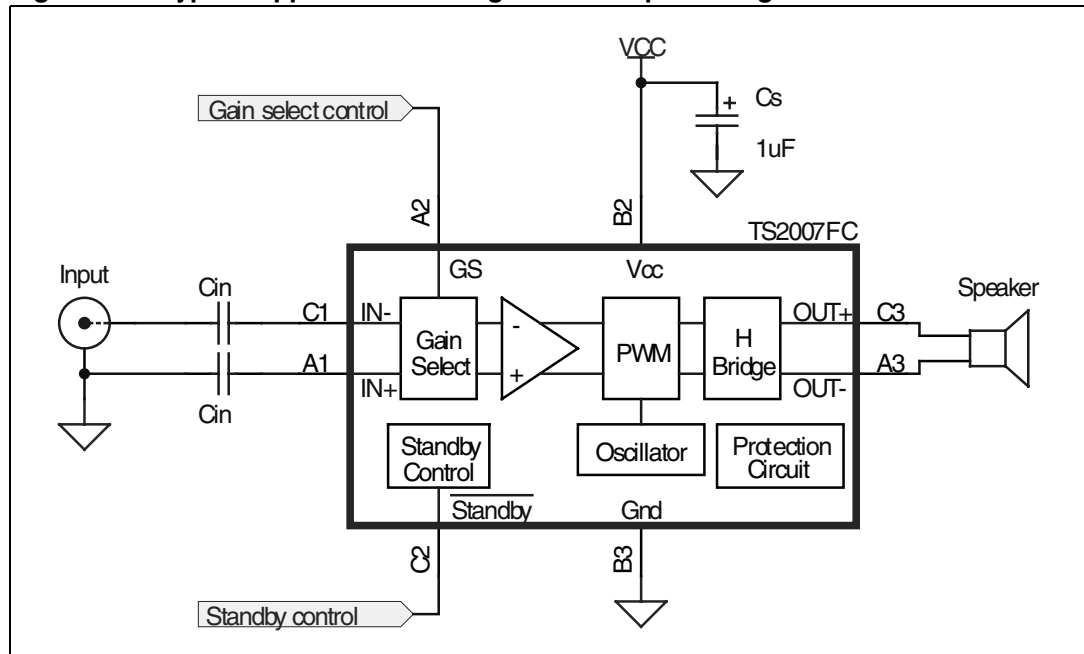

## 4.10 Output filter considerations

The TS2007FC is designed to operate without an output filter. However, due to very sharp transients on the TS2007FC output, EMI radiated emissions may cause some standard compliance issues.

These EMI standard compliance issues can appear if the distance between the TS2007FC outputs and loudspeaker terminal are long (typically more than 50 mm, or 100 mm in both directions). As the PCB layout and internal equipment device are different for each configuration, it is difficult to provide a one-size-fits-all solution.

However, to decrease the probability of EMI issues, there are several simple rules to follow:

- Reduce, as much as possible, the distance between the TS2007FC output pins and the speaker terminals
- Use a ground plane for shielding sensitive wires
- Place, as close as possible to the TS2007FC and in series with each output, a ferrite bead with a rated current of minimum 2.5 A and impedance greater than 50  $\Omega$  at frequencies above 30 MHz
- Allow extra footprint to place, if necessary, a capacitor to short perturbations to ground ([Figure 45](#))

**Figure 45. Ferrite chip bead placement**

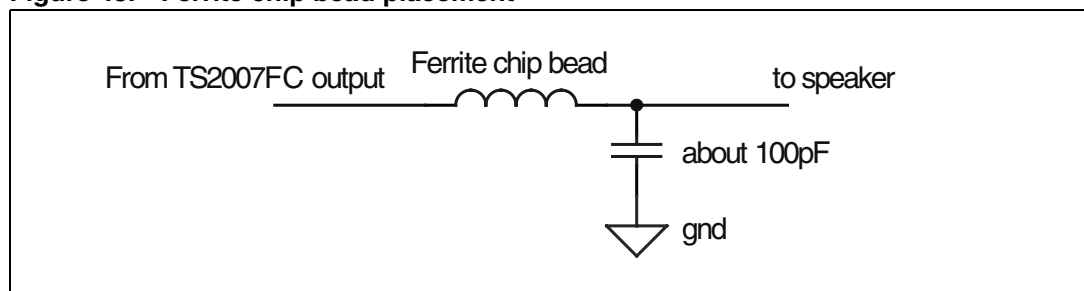

In the case where the distance between the TS2007FC output and the speaker terminals is too long, it is possible to have low frequency EMI issues due to the fact that the typical operating PWM frequency is 280 kHz and fall and rise time of the output signal is less than or equal to 5 ns. In this configuration, it is necessary to use the output filter represented in [Figure 46 on page 24](#), that consists of L1, C1, L2 and C2 as close as possible to the TS2007FC outputs.

When an output filter is used and there exists a possibility to disconnect a load, it is recommended to use an RC network that consists of C3 and R as shown in [Figure 46 on page 24](#). In this case, when the output filter is connected without any load, the filter acts like a short-circuit for input frequencies above 10 kHz. The RC network corrects frequency response of the output filter and compensates this limitation.

**Table 12. Example of component choice**

Component	$R_L = 4 \Omega$	$R_L = 8 \Omega$
L1	15 $\mu$ H / 1.4 A	30 $\mu$ H / 0.7 A
L2	15 $\mu$ H / 1.4 A	30 $\mu$ H / 0.7 A
C1	2 $\mu$ F / 10 V	1 $\mu$ F / 10 V
C2	2 $\mu$ F / 10 V	1 $\mu$ F / 10 V
C3	1 $\mu$ F / 10 V	1 $\mu$ F / 10 V
R	22 $\Omega$ / 0.25 W	47 $\Omega$ / 0.25 W

**Figure 46. LC output filter with RC network**

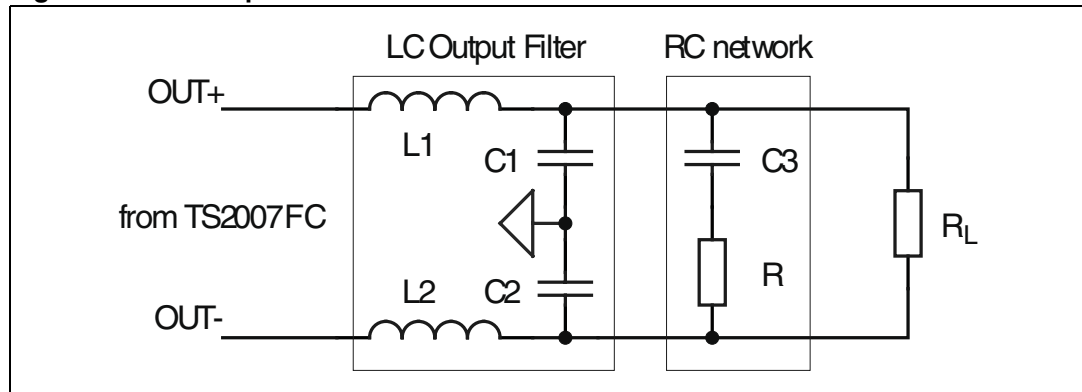

### 4.11 Short-circuit protection

The TS2007FC includes an output short-circuit protection. This protection prevents the device from being damaged if there are fault conditions on the amplifier outputs.

When a channel is in operating mode and a short-circuit occurs directly between two outputs (Out+ and Out-) or between an output and ground (Out+ and GND or Out- and GND), the short-circuit protection detects this situation and puts the amplifier into standby. To put the amplifier back into operating mode, put the standby pin to logical LO and then to logical HI.

### 4.12 Thermal shutdown

The TS2007FC device has an internal thermal shutdown protection in the event of extreme temperatures to protect the device from overheating. Thermal shutdown is active when the device reaches 150°C. When the temperature decreases to safe levels, the circuit switches back to normal operation.

## 5 Package information

In order to meet environmental requirements, ST offers these devices in different grades of ECOPACK® packages, depending on their level of environmental compliance. ECOPACK® specifications, grade definitions and product status are available at: [www.st.com](http://www.st.com). ECOPACK® is an ST trademark.

Figure 47. 9-bump flip-chip pinout (top view)

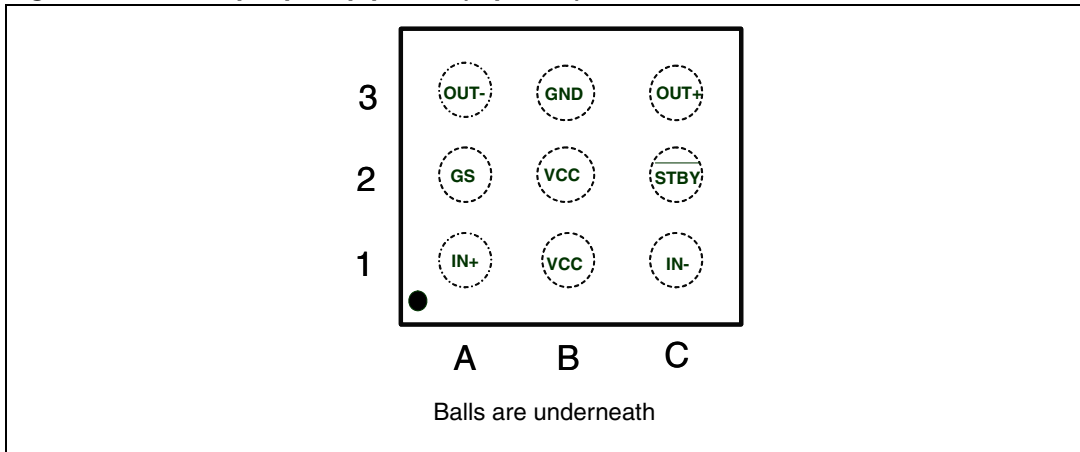

Figure 48. Marking (top view)

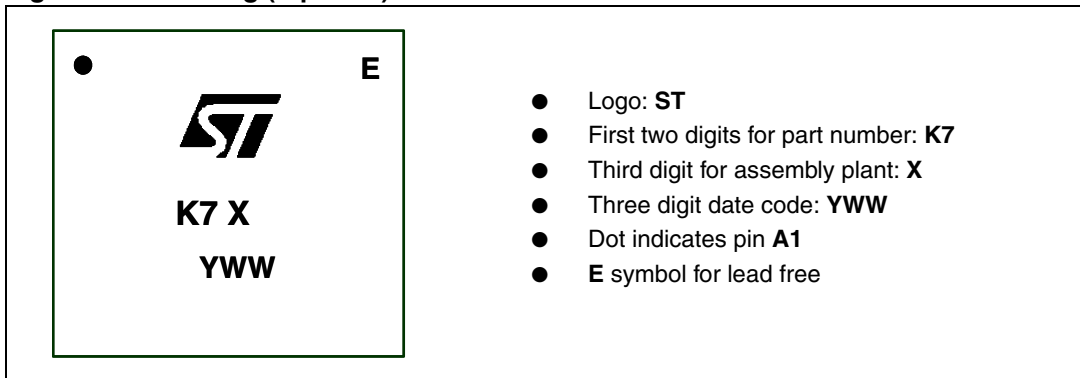
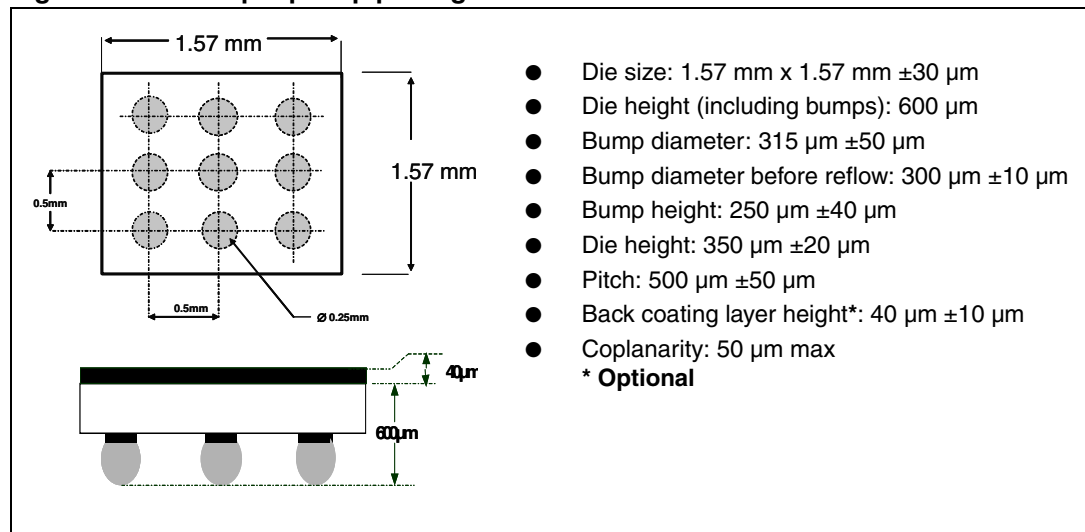

Figure 49. 9-bump flip-chip package mechanical data



## 6 Ordering information

Table 13. Order codes

Order code	Temperature range	Package	Marking
TS2007EIJT	-40° C to +85° C	Flip-chip	K7
TS2007EKIJT	-40° C to +85° C	Flip-chip with back coating	K7

## 7 Revision history

Table 14. Document revision history

Date	Revision	Changes
19-Aug-2008	1	Initial release.
17-May-2011	2	Added minimum $R_L$ to <a href="#">Table 1: Absolute maximum ratings (AMR)</a> Updated ECOPACK® paragraph in <a href="#">Section 5: Package information</a> Minor textual updates

**Please Read Carefully:**

Information in this document is provided solely in connection with ST products. STMicroelectronics NV and its subsidiaries ("ST") reserve the right to make changes, corrections, modifications or improvements, to this document, and the products and services described herein at any time, without notice.

All ST products are sold pursuant to ST's terms and conditions of sale.

Purchasers are solely responsible for the choice, selection and use of the ST products and services described herein, and ST assumes no liability whatsoever relating to the choice, selection or use of the ST products and services described herein.

No license, express or implied, by estoppel or otherwise, to any intellectual property rights is granted under this document. If any part of this document refers to any third party products or services it shall not be deemed a license grant by ST for the use of such third party products or services, or any intellectual property contained therein or considered as a warranty covering the use in any manner whatsoever of such third party products or services or any intellectual property contained therein.

**UNLESS OTHERWISE SET FORTH IN ST'S TERMS AND CONDITIONS OF SALE ST DISCLAIMS ANY EXPRESS OR IMPLIED WARRANTY WITH RESPECT TO THE USE AND/OR SALE OF ST PRODUCTS INCLUDING WITHOUT LIMITATION IMPLIED WARRANTIES OF MERCHANTABILITY, FITNESS FOR A PARTICULAR PURPOSE (AND THEIR EQUIVALENTS UNDER THE LAWS OF ANY JURISDICTION), OR INFRINGEMENT OF ANY PATENT, COPYRIGHT OR OTHER INTELLECTUAL PROPERTY RIGHT.**

**UNLESS EXPRESSLY APPROVED IN WRITING BY AN AUTHORIZED ST REPRESENTATIVE, ST PRODUCTS ARE NOT RECOMMENDED, AUTHORIZED OR WARRANTED FOR USE IN MILITARY, AIR CRAFT, SPACE, LIFE SAVING, OR LIFE SUSTAINING APPLICATIONS, NOR IN PRODUCTS OR SYSTEMS WHERE FAILURE OR MALFUNCTION MAY RESULT IN PERSONAL INJURY, DEATH, OR SEVERE PROPERTY OR ENVIRONMENTAL DAMAGE. ST PRODUCTS WHICH ARE NOT SPECIFIED AS "AUTOMOTIVE GRADE" MAY ONLY BE USED IN AUTOMOTIVE APPLICATIONS AT USER'S OWN RISK.**

Resale of ST products with provisions different from the statements and/or technical features set forth in this document shall immediately void any warranty granted by ST for the ST product or service described herein and shall not create or extend in any manner whatsoever, any liability of ST.

ST and the ST logo are trademarks or registered trademarks of ST in various countries.

Information in this document supersedes and replaces all information previously supplied.

The ST logo is a registered trademark of STMicroelectronics. All other names are the property of their respective owners.

© 2011 STMicroelectronics - All rights reserved

STMicroelectronics group of companies

Australia - Belgium - Brazil - Canada - China - Czech Republic - Finland - France - Germany - Hong Kong - India - Israel - Italy - Japan - Malaysia - Malta - Morocco - Singapore - Spain - Sweden - Switzerland - United Kingdom - United States of America

[www.st.com](http://www.st.com)