



VN540-E / VN540SP-E VN540-12-E

SINGLE HIGH SIDE SMART POWER SOLID STATE RELAY

General Features

Type	V_{demag}	R_{DSon}	I_{out}	V_{CC}
VN540-E VN540SP-E VN540-12-E	$V_{\text{CC}}-55\text{V}$	50m Ω	2.8A	36V

- OUTPUT CURRENT (CONTINUOUS) : 2.8A
- DIGITAL INPUT CLAMPED AT 32V
- PROTECTION AGAINST:
 - LOSS OF GROUND
 - SHORTED LOAD AND OVER-TEMPERATURE
- BUILT-IN CURRENT LIMITER
- UNDERVOLTAGE SHUT-DOWN
- OPEN DRAIN DIAGNOSTIC OUTPUT
- FAST DEMAGNETIZATION OF INDUCTIVE LOADS

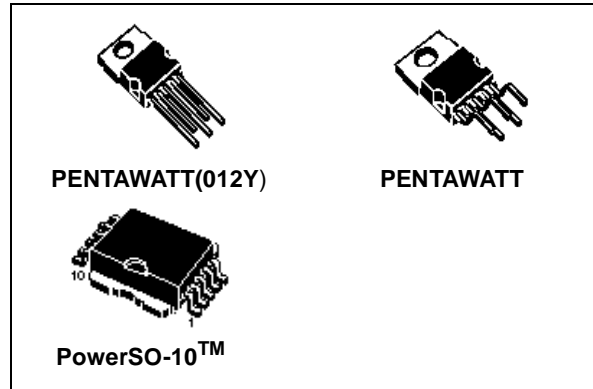

Description

The VN540-E, VN540SP-E, VN540-12-E are monolithic devices designed in STMicroelectronics VIPower technology, intended for driving resistive or inductive loads with one side connected to ground. Active current limitation avoids the system power supply dropping in case of shorted load. Built-in thermal shut-down protects the chip from overtemperature. The open drain diagnostic output indicates over-temperature conditions.

Block Diagram

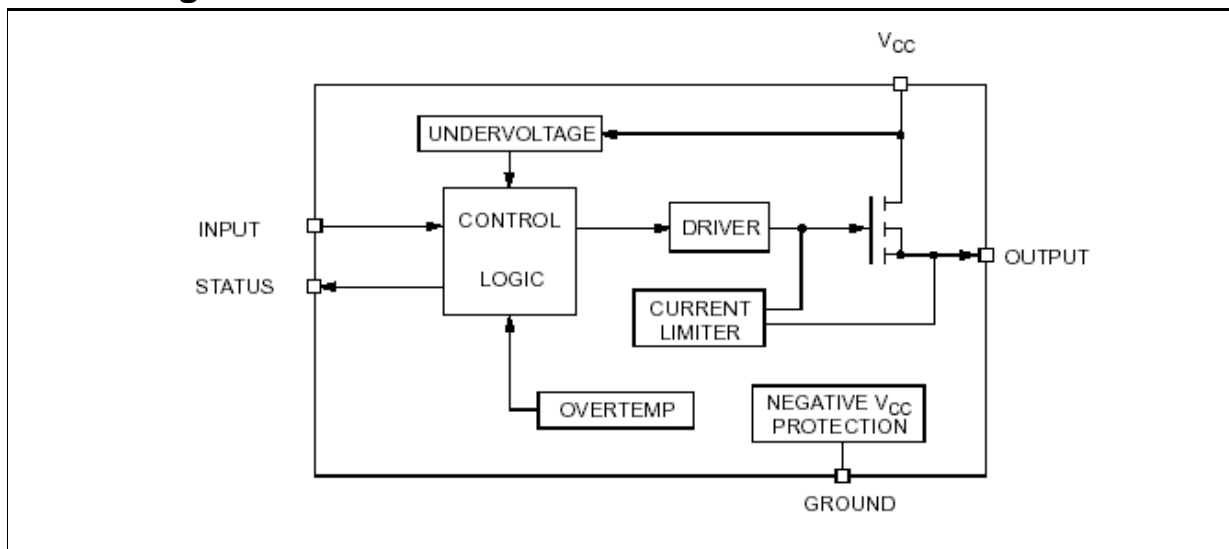

Table 1. Absolute Maximum Rating

Symbol	Parameter	Value	Unit
V_{CC}	Power supply voltage	45	V
$-V_{CC}$	Reverse supply voltage	-4.0	V
I_{OUT}	Maximum DC load current	Internally limited	A
I_R	Reverse output current	-10	A
I_{IN}	Input current	± 10	mA
I_{STAT}	Status pin current	± 10	mA
V_{ESD}	Electrostatic discharge (R = 1.5KW; C = 100pF)	2000	V
P_{TOT}	Power dissipation at $T_c = 25^\circ\text{C}$	Internally limited	w
T_J	Junction operating temperature	Internally limited	$^\circ\text{C}$
T_{STG}	Storage Temperature	-55 to 150	$^\circ\text{C}$
E_{AS}	Single pulse avalanche energy	500	

Figure 1. Connection Diagram (Top View)

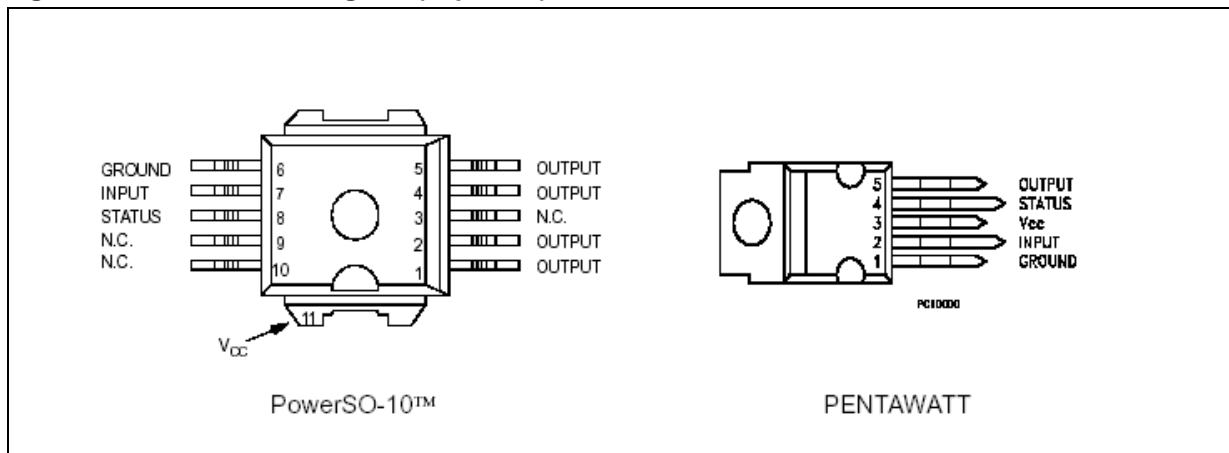

Figure 2. Current and Voltage Conventions

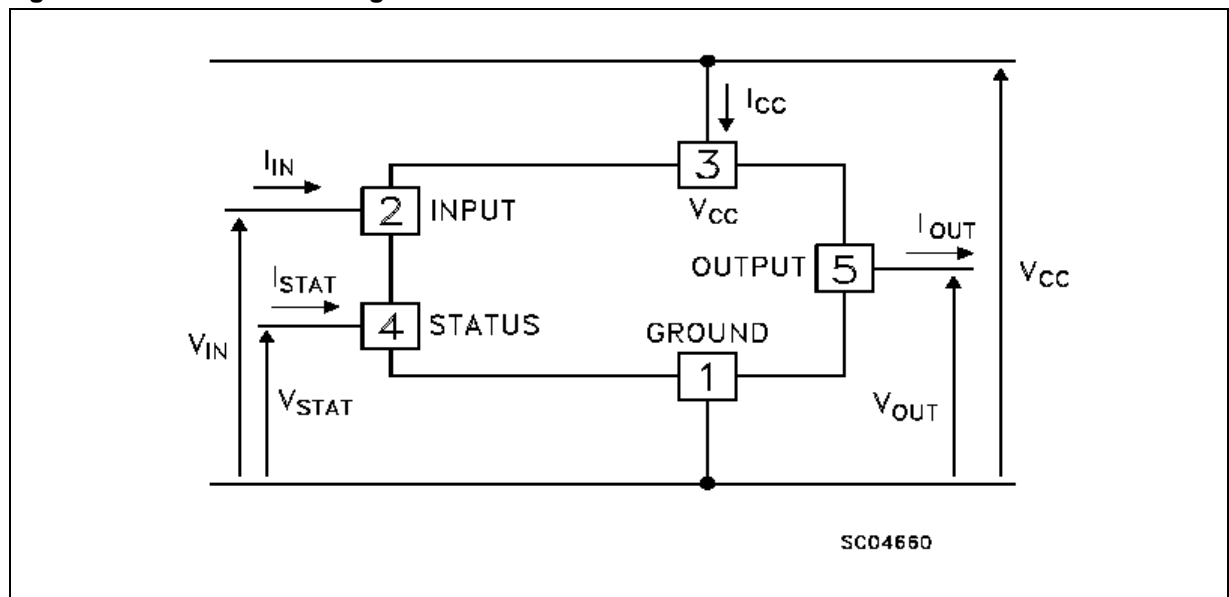

Table 2. Thermal data

Symbol	Parameter		Value		Unit
			PowerSO-10	Pentawatt	
R _{thJC}	Thermal resistance junction-case	Max	1.5	2.0	°C/W
R _{thJA}	Thermal resistance junction-ambient	Max	50	60	°C/W

Electrical Characteristics (10V < V_{CC} < 36V; -25°C < T_J < 85°C; unless otherwise specified)

Table 3. Power Section

Symbol	Parameter	Test Conditions	Min.	Typ.	Max.	Unit
V _{CC}	Supply voltage		10		36	V
R _{ON}	On state resistance	I _{OUT} = 2.8A; T _J = 25°C I _{OUT} = 2.8A;			50 90	mΩ mΩ
I _S	Supply current	OFF state ON state; T _J = 125°C I _{OUT} = 0A			1 3	mA mA
I _{LS}	Output leakage current	Channel OFF V _{CC} = 45V			100	μA
I _{LGND}	Output current at turn-off	V _{CC} = V _{IN} = V _{GND} = V _{STAT} = 24V T _J = -25°C < T _J < 100°C			2	mA
V _{OL}	Low state output voltage	V _{IN} = V _{IL} ; R _{LOAD} >= 10MΩ			1.5	V
V _{demag}	Output voltage at turn-off	I _{OUT} = 2.8A; L _{LOAD} >= 1mH	V _{CC} -65	V _{CC} -55	V _{CC} -45	V

Table 4. Switching

Symbol	Parameter	Test Conditions	Min.	Typ.	Max.	Unit
t _{d(ON)}	Turn-on delay on output current	I _{OUT} = 2.8A, Resistive Load Input rise time < 0.1μs, V _{CC} = 24V; T _J = 25°C		40		μs
t _r	Rise time of output current	I _{OUT} = 2.8A, Resistive Load Input rise time < 0.1μs, V _{CC} = 24V; T _J = 25°C		60		μs
t _{d(OFF)}	Turn-off delay time of output current	I _{OUT} = 2.8A, Resistive Load Input rise time < 0.1μs, V _{CC} = 24V; T _J = 25°C		60		μs
t _f	Fall time of Output current	I _{OUT} = 2.8A, Resistive Load Input rise time < 0.1μs, V _{CC} = 24V; T _J = 25°C		25		μs
di/dt _(on)	Turn-on current average slope	I _{OUT} = 2.8A, I _{OUT} = I _{LIM} ; 25°C < T _J < 140°C			0.5 2	A/μs
di/dt _(off)	Turn-off current average slope	I _{OUT} = 2.8A, I _{OUT} = I _{LIM} ; 25°C < T _J < 140°C			2 4	A/μs

Table 5. Logical Input

Symbol	Parameter	Test Conditions	Min.	Typ.	Max.	Unit
V_{IL}	Input low level voltage				2.0	V
V_{IH}	Input high level voltage		3.5			V
$V_{I(HYST)}$	Input hysteresis voltage			0.5		V
I_{IN}	Input current	$V_{IN} = 30V$ $V_{IN} = 2.0V$	25		300	μA μA
V_{ICL}	I/O Input clamp voltage <i>Note 1</i>	$I_{IN} = 1mA$ $I_{IN} = -1mA$	32	36 -0.7		V V

Note: 1 The input voltage is internally clamped at 32V minimum, it is possible to connect the input pins to an higher voltage via an external resistor calculate to not exceed 10mA

Table 6. Protection and Diagnostic

Symbol	Parameter	Test Conditions	Min.	Typ.	Max.	Unit
V_{STAT}	Status output voltage	$I_{STAT} = 5mA$ (Fault condition)			1	V
$V_{SCL(*)}$	Status clamp voltage	$I_{STAT} = 1mA$ $I_{STAT} = -1mA$	32	36 -0.7		V V
I_{STAT}	Leakage on diagnostic pin in high state	$V_{STAT} = 5V$			10	μA
V_{USD}	Undervoltage shut down		5.0		8.0	V
I_{LIM}	DC Short circuit current	$V_{CC} = 24V$; $R_{LOAD} < 10m\Omega$	2.8	5.0	8.0	A
I_{OVPK}	Peak short circuit current	$V_{CC} = 24V$; $V_{IN} = 30$; $R_{LOAD} < 10m\Omega$			4	A
t_{SC}	Delay time of current limiter				100	μs
T_{TSD}	Thermal shut down temperature		150	170		$^{\circ}C$
T_R	Thermal reset temperature		135	155		$^{\circ}C$

(*)Status determination > 100ms after the switching edge.

Figure 3. Switching Characteristics

Table 7. Truth Table

	INPUT	OUTPUT	STATUS
Normal operation	L	L	H
	H	H	H
Overtemperature	L	L	H
	H	L	L
Undervoltage	L	L	H
	H	L	H
Shorted load (Current limitation)	L	L	H
	H	H	H

Figure 4. Peak Short Test Circuit

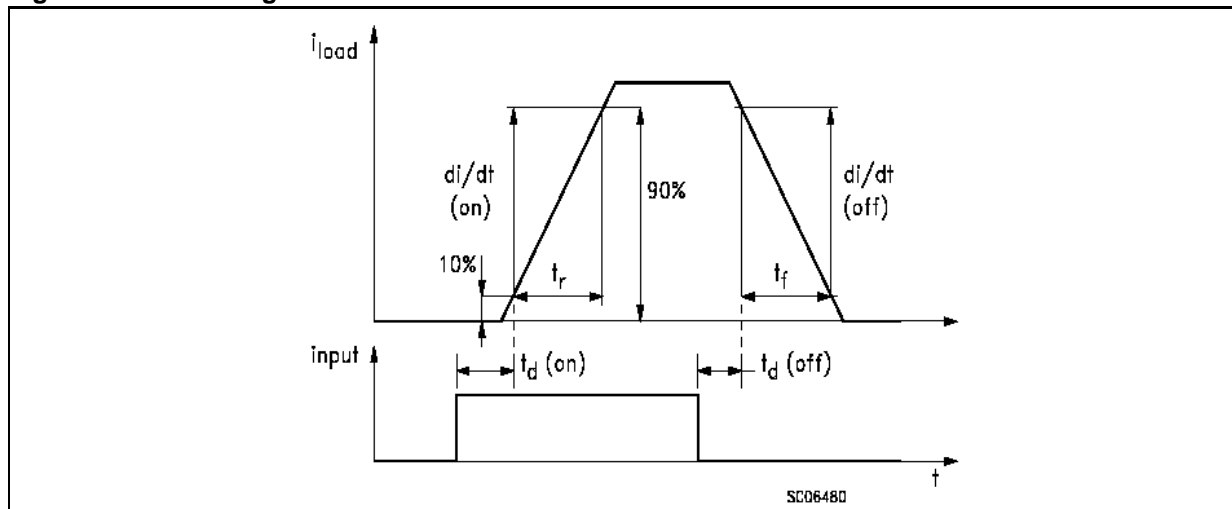
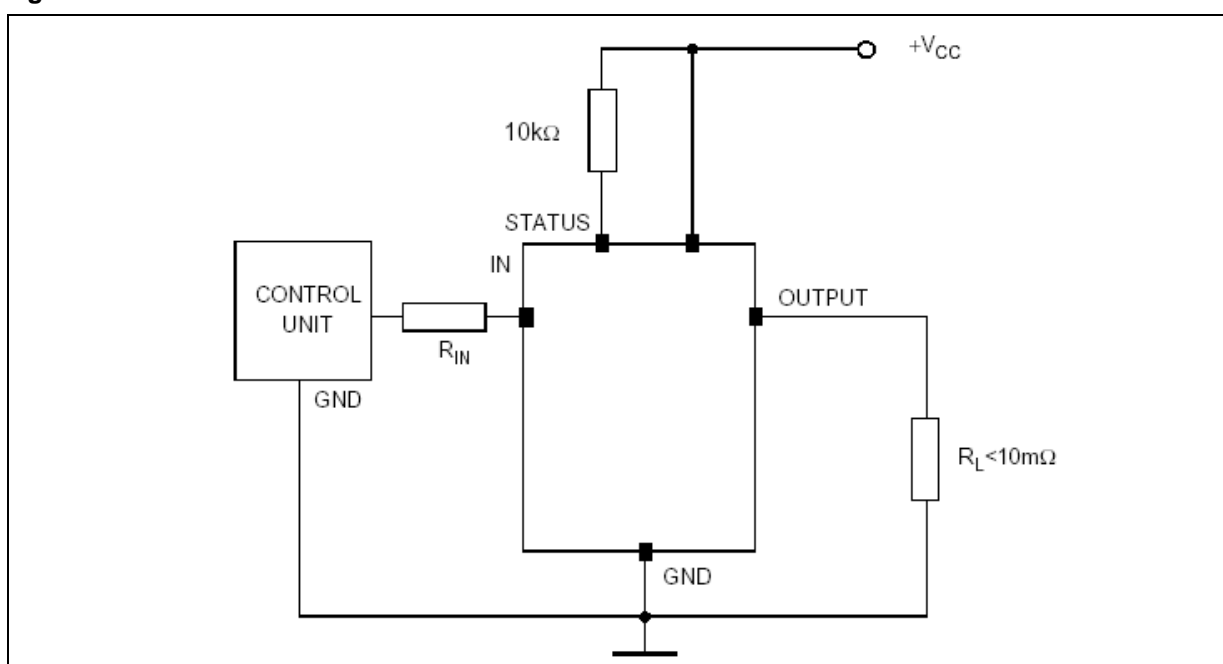

Figure 5. Switching Waveforms

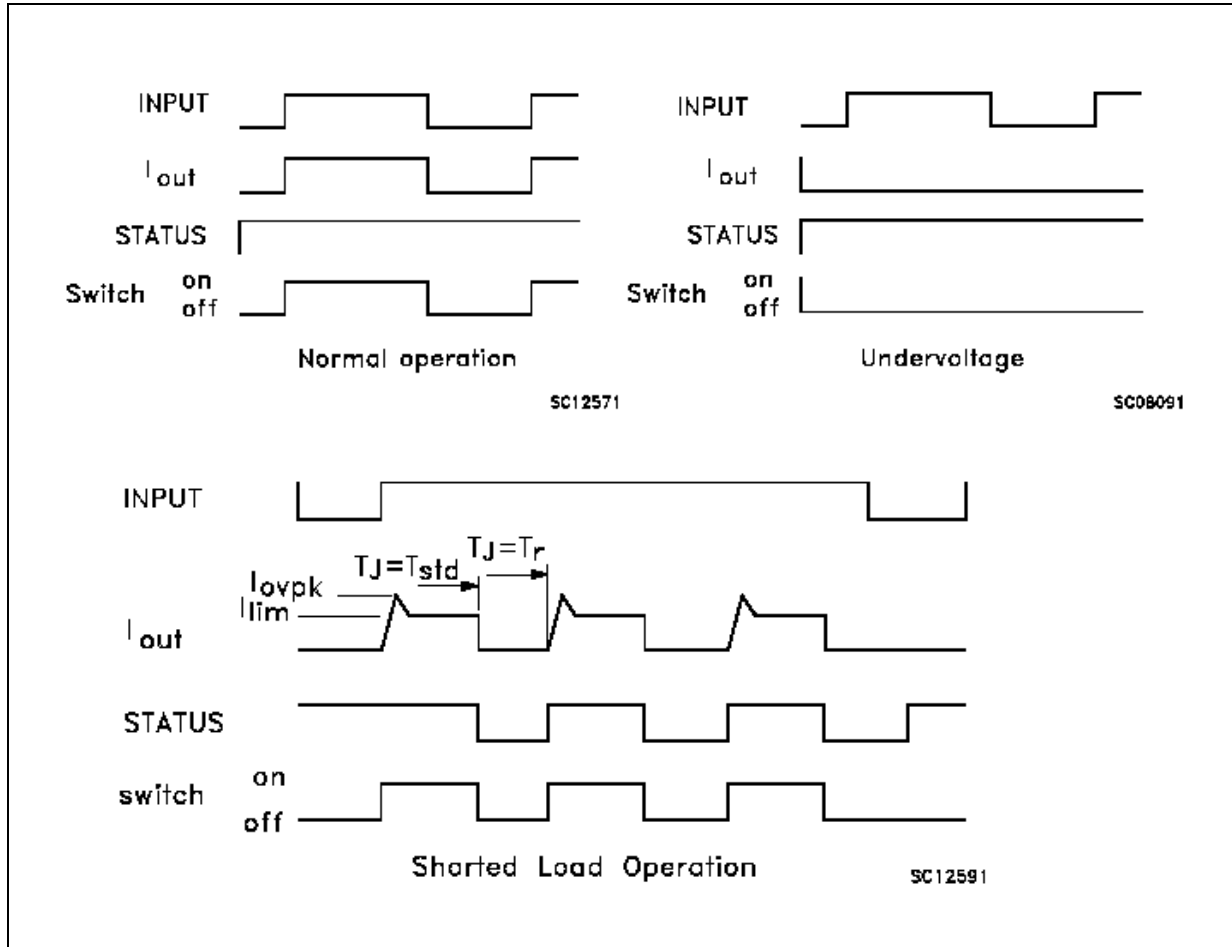
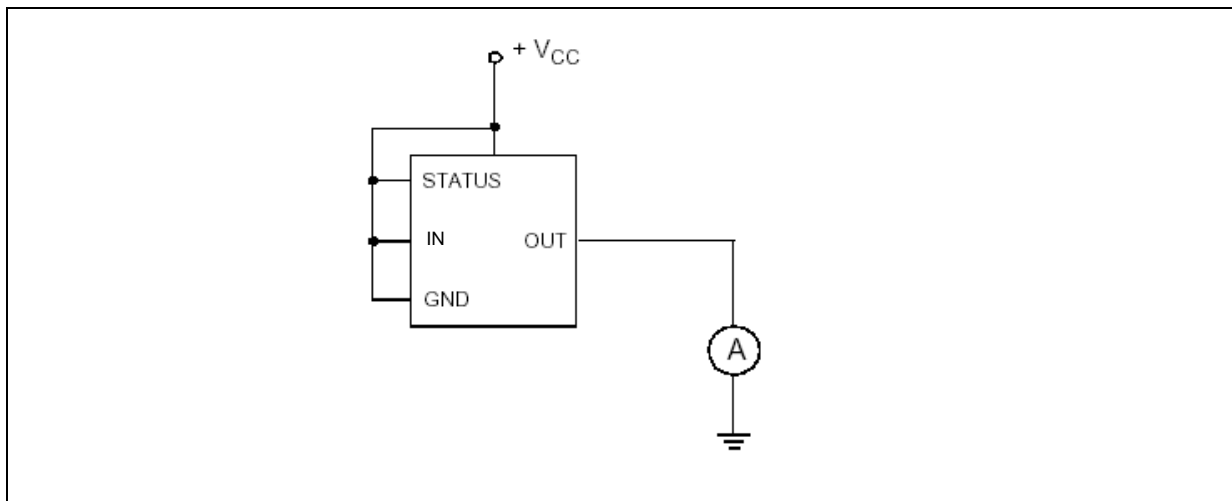

Figure 6. I_{LGND} Test Configuration



Package Mechanical Data

In order to meet environmental requirements, ST offers these devices in ECOPACK[®] packages. These packages have a Lead-free second level interconnect. The category of second Level Interconnect is marked on the package and on the inner box label, in compliance with JEDEC Standard JESD97. The maximum ratings related to soldering conditions are also marked on the inner box label. ECOPACK is an ST trademark. ECOPACK specifications are available at: www.st.com.

PENTAWATT (IN-LINE) MECHANICAL DATA

DIM.	mm.			inch		
	MIN.	TYP.	MAX.	MIN.	TYP.	MAX.
A			4.8			0.189
C			1.37			0.054
D	2.4		2.8	0.094		0.110
D1	1.2		1.35	0.047		0.053
E	0.35		0.55	0.014		0.022
F	0.8		1.05	0.031		0.041
F1	1		1.4	0.039		0.055
G	3.2	3.4	3.6	0.126	0.134	0.142
G1	6.6	6.8	7	0.260	0.268	0.276
H2			10.4			0.409
H3	10.05		10.4	0.396		0.409
L2	23.05	23.4	23.8	0.907	0.921	0.937
L3	25.3	25.65	26.1	0.996	1.010	1.028
L5	2.6		3	0.102		0.118
L6	15.1		15.8	0.594		0.622
L7	6		6.6	0.236		0.260
Diam.	3.65		3.85	0.144		0.152

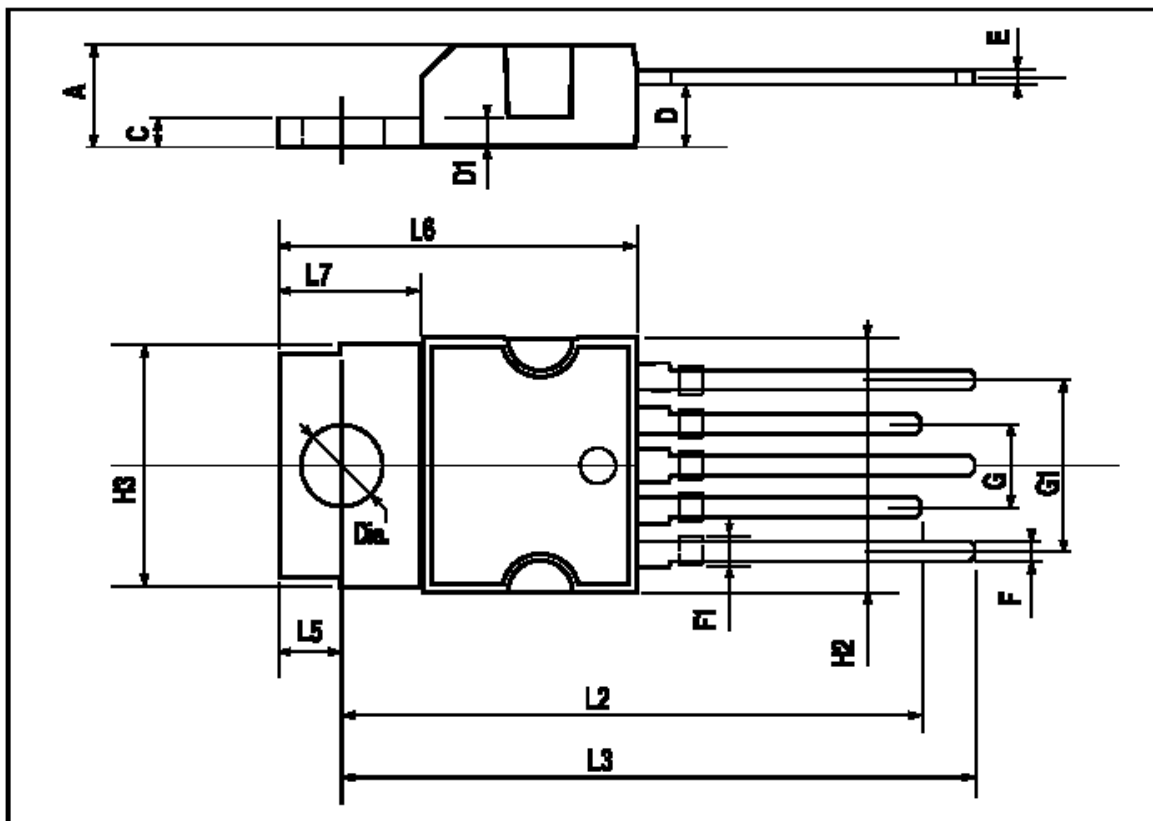

PENTAWATT (VERTICAL) MECHANICAL DATA

DIM.	mm.			inch		
	MIN.	TYP	MAX.	MIN.	TYP.	MAX.
A			4.8			0.189
C			1.37			0.054
D	2.4		2.8	0.094		0.110
D1	1.2		1.35	0.047		0.053
E	0.35		0.55	0.014		0.022
F	0.8		1.05	0.031		0.041
F1	1		1.4	0.039		0.055
G	3.2	3.4	3.6	0.126	0.134	0.142
G1	6.6	6.8	7	0.260	0.268	0.276
H2			10.4			0.409
H3	10.05		10.4	0.396		0.409
L		17.85			0.703	
L1		15.75			0.620	
L2		21.4			0.843	
L3		22.5			0.886	
L5	2.6		3	0.102		0.118
L6	15.1		15.8	0.594		0.622
L7	6		6.6	0.236		0.260
M		4.5			0.177	
M1		4			0.157	
Diam.	3.65		3.85	0.144		0.152

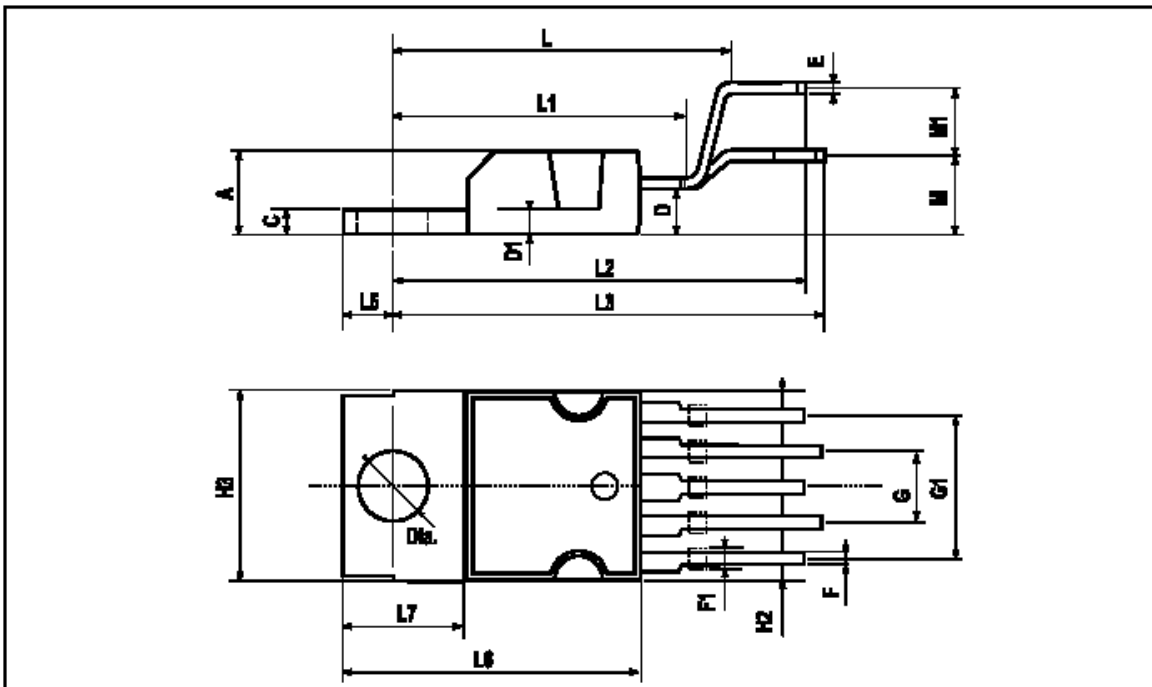

PowerSO-10™ MECHANICAL DATA

DIM.	mm.			inch		
	MIN.	TYP	MAX.	MIN.	TYP.	MAX.
A	3.35		3.65	0.132		0.144
A (*)	3.4		3.6	0.134		0.142
A1	0.00		0.10	0.000		0.004
B	0.40		0.60	0.016		0.024
B (*)	0.37		0.53	0.014		0.021
C	0.35		0.55	0.013		0.022
C (*)	0.23		0.32	0.009		0.0126
D	9.40		9.60	0.370		0.378
D1	7.40		7.60	0.291		0.300
E	9.30		9.50	0.366		0.374
E2	7.20		7.60	0.283		300
E2 (*)	7.30		7.50	0.287		0.295
E4	5.90		6.10	0.232		0.240
E4 (*)	5.90		6.30	0.232		0.248
e		1.27			0.050	
F	1.25		1.35	0.049		0.053
F (*)	1.20		1.40	0.047		0.055
H	13.80		14.40	0.543		0.567
H (*)	13.85		14.35	0.545		0.565
h		0.50			0.002	
L	1.20		1.80	0.047		0.070
L (*)	0.80		1.10	0.031		0.043
α	0°		8°	0°		8°
α (*)	2°		8°	2°		8°

(*) Muar only POA P013P

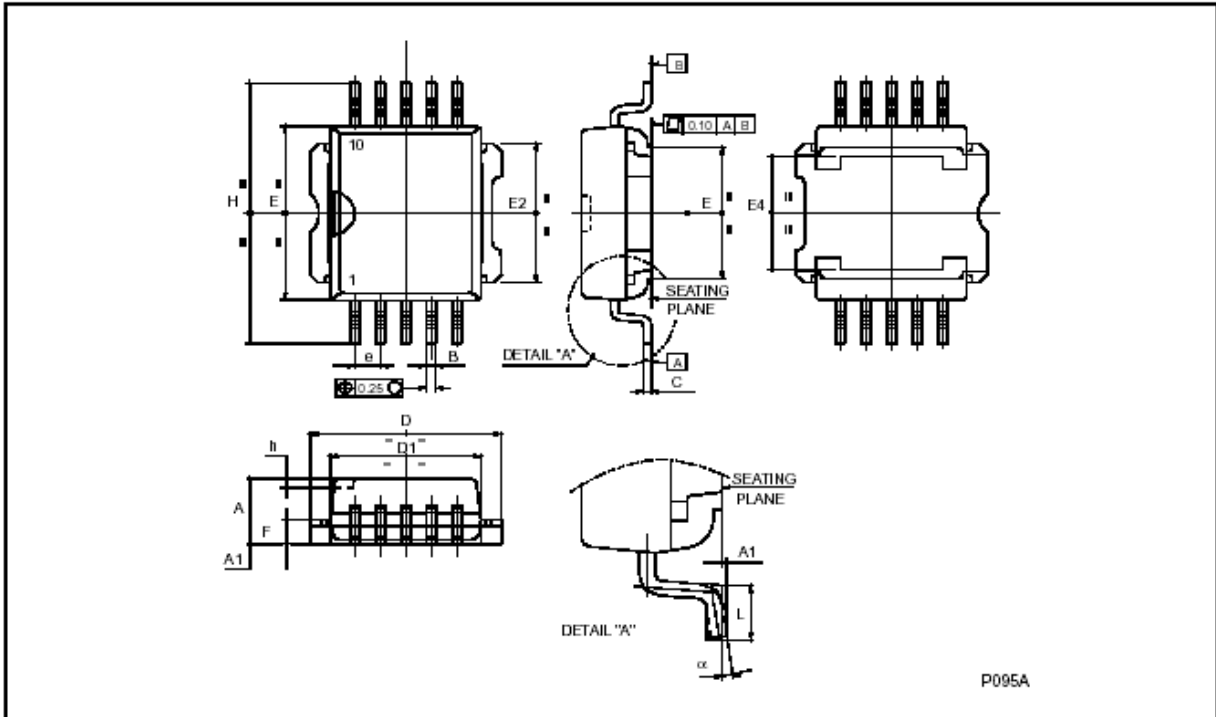

Table 8. Order Codes

Package	Tube	Tape and Reel
PowerSO-10™	VN540SP-E	VN540SPTR-E
PENTAWATT vertical	VN540-E	
PENTAWATT straight	VN540-12-E	

Table 9. Revision History

Date	Revision	Changes
2-Nov-2005	1	Initial release

Information furnished is believed to be accurate and reliable. However, STMicroelectronics assumes no responsibility for the consequences of use of such information nor for any infringement of patents or other rights of third parties which may result from its use. No license is granted by implication or otherwise under any patent or patent rights of STMicroelectronics. Specifications mentioned in this publication are subject to change without notice. This publication supersedes and replaces all information previously supplied. STMicroelectronics products are not authorized for use as critical components in life support devices or systems without express written approval of STMicroelectronics.

The ST logo is a registered trademark of STMicroelectronics.
All other names are the property of their respective owners

© 2005 STMicroelectronics - All rights reserved

STMicroelectronics group of companies

Australia - Belgium - Brazil - Canada - China - Czech Republic - Finland - France - Germany - Hong Kong - India - Israel - Italy - Japan -
Malaysia - Malta - Morocco - Singapore - Spain - Sweden - Switzerland - United Kingdom - United States of America

www.st.com

