

Multiple RS-232 drivers and receivers

Features

- Meets and exceeds the requirements of EIA/TIA-232-E and ITUV.28 standard
- Single chip with easy interface between UART and serial port connector of IBM PC/AT™ and compatibles
- Designed to support data rates up to 120 kbps
- Pinout compatible with ST75C185

Description

The ST75185C contains three drivers and five receivers. The pinout matches the DB9S connector design in order to decrease the part count, reduce the board space required and allow easy interconnection of the UART and serial port connector of IBM PC/AT™ and compatibles. The bipolar circuits and processing of the ST75185C provides a rugged low-cost solution for this function at the expense of quiescent power and external passive components relative to the ST75C185.

The ST75185C complies with the requirements of the EIA/TIA 232-E and ITU (formally CCITT) v.28 standards. These standards are for data interchange between a host computer and peripheral at signalling rates up to 20 k-bits/s. The switching speeds of the ST75185C are fast enough to support rates up to 120 K-bits/s with lower capacitive loads (shorter cables). Inter-operability at the higher signalling rates cannot be assured unless the designer has design control of the cable and the interface circuits at the both ends. For inter-operability at signalling rates to

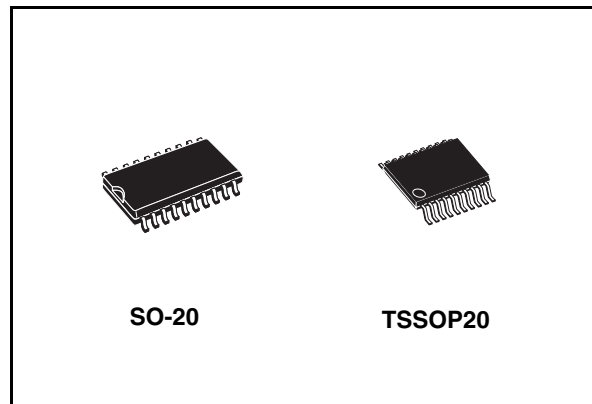

120 k-bits/s, use of EIA/ITA-423-B (ITU v.10) and EIA/ITA-422-B (ITU v.11) standards are recommended.

The ST75185C is characterized for operation over the range of 0°C to 70 °C.

Table 1. Device summary

Order codes	Temperature range	Packages	Packaging
ST75185CTR	0 to 70 °C	TSSOP20 (tape and reel)	2500 parts per reel
ST75185CDR	0 to 70 °C	SO-20 (tape and reel)	1000 parts per reel

Contents

1	Pin configuration	3
2	Maximum ratings	4
3	Electrical characteristics	6
4	Typical application	9
5	Typical characteristics	13
6	Application information: diodes on power supply	15
7	Package mechanical data	16
8	Revision history	21

1 Pin configuration

Figure 1. Pin connection IEC logic symbol and logic diagram

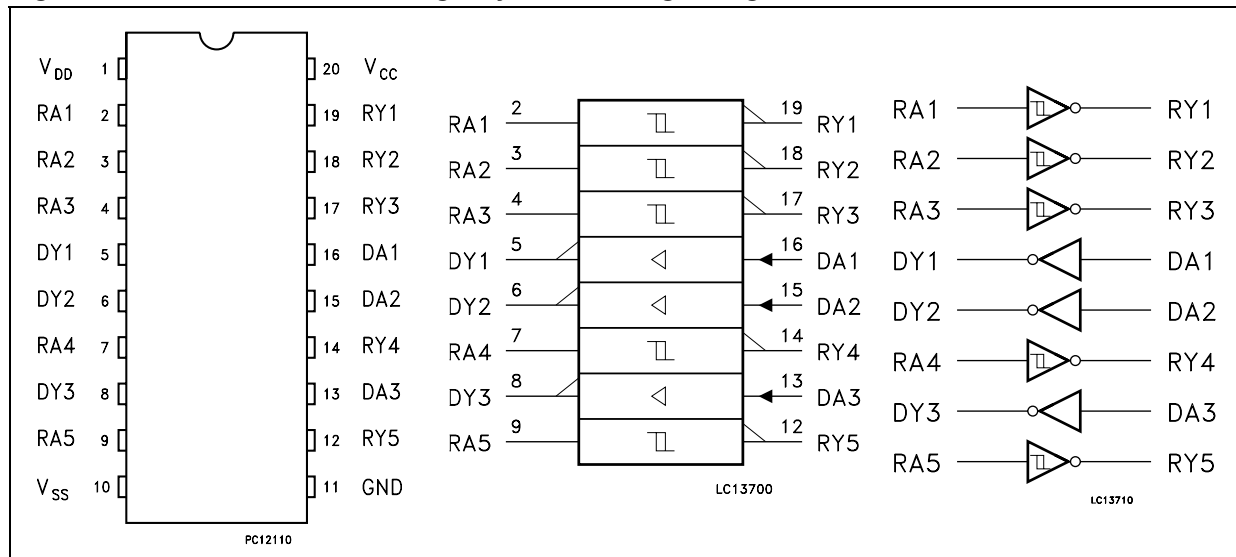

Table 2. Pin description

Pin n°	Symbol	Name and function
1	V _{DD}	Supply voltage (+12 V)
2	RA1	First receiver input
3	RA2	Second receiver input
4	RA3	Third receiver input
5	DY1	First driver output
6	DY2	Second driver output
7	RA4	Fourth receiver input
8	DY3	Third driver output
9	RA5	Fifth receiver input
10	V _{SS}	Supply voltage (-12V)
11	GND	Ground
12	RY5	Fifth receiver output
13	DA3	Third driver input
14	RY4	Fourth receiver output
15	DA2	Second driver input
16	DA1	First driver input
17	RY3	Third receiver output
18	RY2	Second receiver output
19	RY1	First receiver output
20	V _{CC}	Supply voltage (+5 V)

2 Maximum ratings

Table 3. Absolute maximum ratings over operating free-air temperature range

Symbol	Parameter	Value	Unit
V _{DD}	Supply voltage ⁽¹⁾	15	V
V _{SS}	Supply voltage ⁽¹⁾	-15	V
V _{CC}	Supply voltage ⁽¹⁾	10	V
V _I	Input voltage range (Driver)	-15 to 7	V
V _I	Input voltage range (Receiver)	-30 to 30	V
V _O	Output voltage range (Driver)	-15 to 15	V
I _O	Receiver low level output current	20	mA
P _D	Continuous total power dissipation	See dissipation rating table	
T _A	Operating free-air temperature range	0 to 70	°C
T _{STG}	Storage temperature range	-65 to + 150	°C
T _L	Lead temperature 1.6 mm. from case for 10 sec.	260	°C

1. All voltage are with respect to the network ground terminal.

Note: Absolute maximum ratings are those values beyond which damage to the device may occur. Functional operation under these condition is not implied.

Table 4. Dissipation rating table

Package	Power rating at T _A ≤ 25°C	Derating factor above T _A = 25°C	Power rating at T _A ≤ 70°C
MICROPACKAGE (D)	1125 mW	9.0 mW/°C	720 mW

Table 5. Thermal data

Symbol	Parameter	TSSOP20	Unit
R _{thJC}	Thermal resistance junction-case	27.22	°C/W
R _{thJA}	Thermal resistance junction-ambient	114.5 ⁽¹⁾	°C/W

1. This value is referred to single-layer PCB, JEDEC standard test board.

Table 6. Recommended operating conditions

Symbol	Parameter	Min.	Max.	Unit.
V_{DD}	Supply voltage	7.5	15	V
V_{SS}	Supply voltage	-7.5	-15	V
V_{CC}	Supply voltage	4.5	5.5	V
V_I	Driver input voltage	0	V_{CC}	V
I_{OH}	High level output current	Driver	-6	mA
		Receiver	-0.5	
I_{OL}	Low level output current	Driver	6	mA
		Receiver	16	
T_A	Operating free-air temperature range	0	70	°C

3 Electrical characteristics

Table 7. Supply currents

Symbol	Parameter	Test conditions			Value			Unit
		V _{DD}	V _{SS}		Min.	Typ.	Max.	
I _{DD}	Supply current from V _{DD}	9	-9	No load. all inputs at 1.9V			15	mA
		12	-12				19	
		15	-15				25	
		9	-9	No load. all inputs at 0.8V			4.5	mA
		12	-12				5.5	
		15	-15				9	
I _{SS}	Supply current from V _{SS}	9	-9	No load. all inputs at 1.9V			-15	mA
		12	-12				-19	
		15	-15				-25	
		9	-9	No load. all inputs at 0.8V			-3.2	mA
		12	-12				-3.2	
		15	-15				-3.2	
I _{CC}	Supply current from V _{CC}	No load. All inputs at 5V V _{CC} = 5V					30	mA

$V_{DD} = 9\text{ V}$, $V_{SS} = -9\text{ V}$, $V_{CC} = 5\text{ V}$, unless otherwise specified.

Table 8. Driver electrical characteristics over operating free-air temperature range

Symbol	Parameter	Test conditions	Value			Unit
			Min.	Typ.	Max.	
V_{OH}	High level output voltage	$V_{IL} = 0.8\text{ V}$, $R_L = 3\text{ k}\Omega$ (See Figure 3)	6	7.5		V
V_{OL}	Low level output voltage (Note 3)	$V_{IH} = 1.9\text{ V}$, $R_L = 3\text{ k}\Omega$ (See Figure 3)		-7.5	-6	V
I_{IH}	High level input current	$V_I = 5\text{ V}$ (See Figure 4)			10	μA
I_{IL}	Low level input current	$V_I = 0\text{ V}$ (See Figure 4)			-1.6	mA
$I_{OS(H)}$	High level short circuit output current (Note 4)	$V_{IL} = 0.8\text{ V}$, $V_O = 0\text{ V}$ (See Figure 3)	-4.5	-12	-19.5	mA
$I_{OS(L)}$	Low level short circuit output current	$V_{IH} = 2\text{ V}$, $V_O = 0\text{ V}$ (See Figure 3)	4.5	12	19.5	mA
R_O	Output resistance	$V_{DD} = V_{SS} = V_{CC} = 0\text{ V}$ $V_O = -2\text{ to }2\text{ V}$ (Note 3)	300			Ω

Note: 1 The algebraic convention, where the more positive (less negative) limits designated as maximum, is used in this datasheet for logic levels only (e.g. if -10 V is a maximum, the typical value is a more negative voltage).

2 Output short circuit conditions must maintain the total power dissipation below absolute maximum ratings.

3 Test conditions are those specified by EIA-232-E and as listed above.

$V_{DD} = 12\text{ V}$, $V_{SS} = -12\text{ V}$, $V_{CC} = 5\text{ V}$, $T_A = 25\text{ }^\circ\text{C}$

Table 9. Driver switching characteristics

Symbol	Parameter	Test conditions	Value			Unit
			Min.	Typ.	Max.	
t_{PLH}	Propagation Delay Time, Low to High Level Output	$R_L = 3\text{ to }7\text{ k}\Omega$, $C_L = 15\text{ pF}$ (See Figure 5 , Figure 6)		315	500	ns
t_{PHL}	Propagation Delay Time, High to Low Level Output	$R_L = 3\text{ to }7\text{ k}\Omega$, $C_L = 15\text{ pF}$ (See Figure 5 , Figure 6)		75	175	ns
t_{TLH}	Transition Time Low to High Level Output	$R_L = 3\text{ to }7\text{ k}\Omega$, $C_L = 15\text{ pF}$ (See Figure 5 , Figure 6)		60	100	ns
		$R_L = 3\text{ to }7\text{ k}\Omega$, $C_L = 2500\text{ pF}$ (Note 4 , Figure 5 , Figure 6)		1.7	2.5	μs
t_{THL}	Transition Time High to Low Level Output	$R_L = 3\text{ to }7\text{ k}\Omega$, $C_L = 15\text{ pF}$ (See Figure 5 , Figure 6)		40	7.5	ns
		$R_L = 3\text{ to }7\text{ k}\Omega$, $C_L = 2500\text{ pF}$ (Note 4 , Figure 5 , Figure 6)		1.5	2.5	μs

4 Measured between -3 V and 3 V points of output waveform (EIA-232-E conditions), all unused inputs are tied.

Table 10. Receiver electrical characteristics over operating conditions

Symbol	Parameter	Test conditions	Value			Unit
			Min.	Typ.	Max.	
V_{T+}	Positive going threshold voltage	(See Figure 9)		2.2	2.4	V
V_{T-}	Negative going threshold voltage	$T_A = 25\text{ }^\circ\text{C}$ (See Figure 9)	0.75	0.97		V
V_{hys}	Input hysteresis ($V_{T+} - V_{T-}$)		0.5			V
V_{OH}	High level output voltage	$I_{OH} = -0.5\text{ mA}$ $V_{IH} = 0.75\text{ V}$	2.6	4	5	V
		Inputs Open	2.6			
V_{OL}	Low level output voltage	$V_I = 3\text{ V}$ $I_{OL} = 10\text{ mA}$		0.2	0.45	V
I_{IH}	High level input current	$V_I = 25\text{ V}$ (See Figure 9)	3.6		8.3	mA
		$V_I = 3\text{ V}$ (See Figure 9)	0.43			
I_{IL}	Low level input current	$V_I = -25\text{ V}$ (See Figure 9)	-3.6		-8.3	mA
		$V_I = -3\text{ V}$ (See Figure 9)	-0.43			
I_{OS}	Short-circuit output current	$V_I = 0\text{ V}$ $V_O = 0\text{ V}$ (See Figure 7)		-3.4	-12	mA

Note: All typical values are at $T_A = 25\text{ }^\circ\text{C}$, $V_{CC} = 5\text{ V}$, $V_{DD} = 9\text{ V}$ and $V_{SS} = -9\text{ V}$

$V_{DD} = 12\text{ V}$, $V_{SS} = -12\text{ V}$, $V_{CC} = 5\text{ V}$ $T_A = 25\text{ }^\circ\text{C}$

Table 11. Receiver switching characteristics

Symbol	Parameter	Test conditions	Value			Unit
			Min.	Typ.	Max.	
t_{PLH}	Propagation delay time low to high level output	$R_L = 5\text{ k}\Omega$ $C_L = 50\text{ pF}$ (See Figure 9)		400	1000	ns
t_{PHL}	Propagation delay time high to low level output	$R_L = 5\text{ k}\Omega$ $C_L = 50\text{ pF}$ (See Figure 9)		70	150	ns
t_{TLH}	Transition time low to high level output	$R_L = 5\text{ k}\Omega$ $C_L = 50\text{ pF}$ (See Figure 9)		200	525	ns
t_{THL}	Transition time high to low level output	$R_L = 5\text{ k}\Omega$ $C_L = 50\text{ pF}$ (See Figure 9)		20	60	ns

Figure 4. Driver test circuit for I_{IH} and I_{IL}

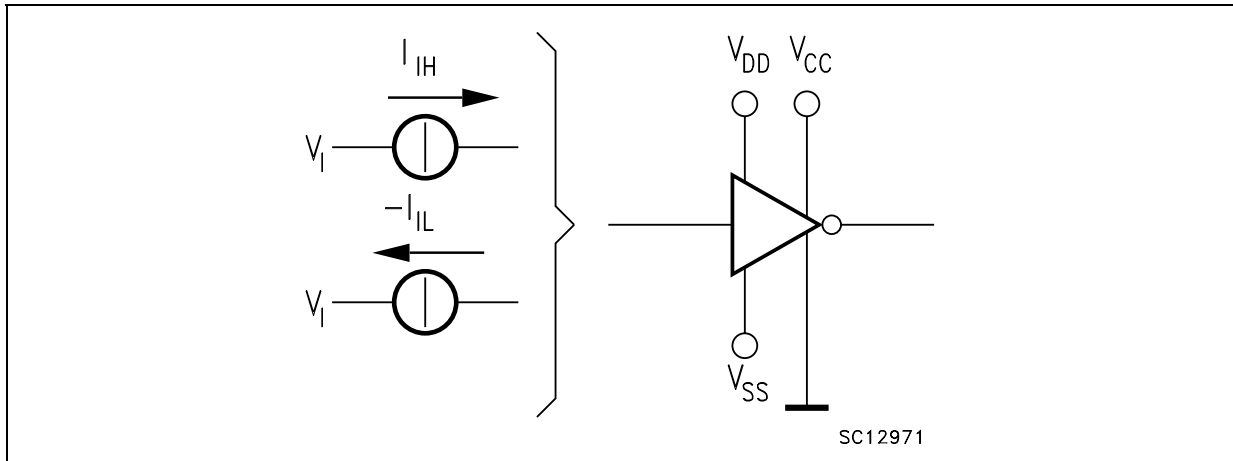

Figure 5. Driver test circuit

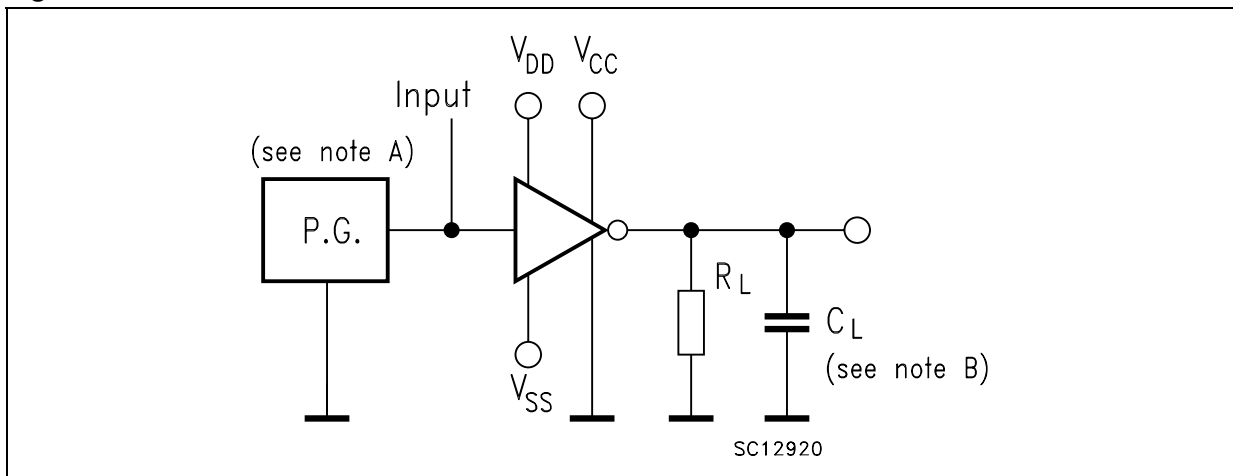

Figure 6. Driver voltage waveforms

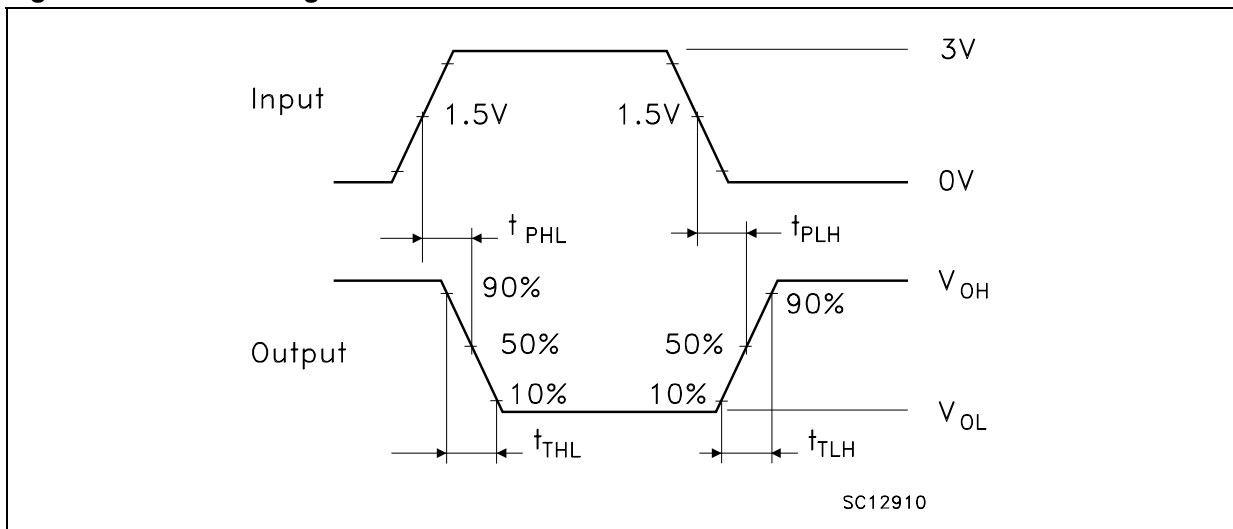

Figure 7. Receiver test circuit for I_{OS}

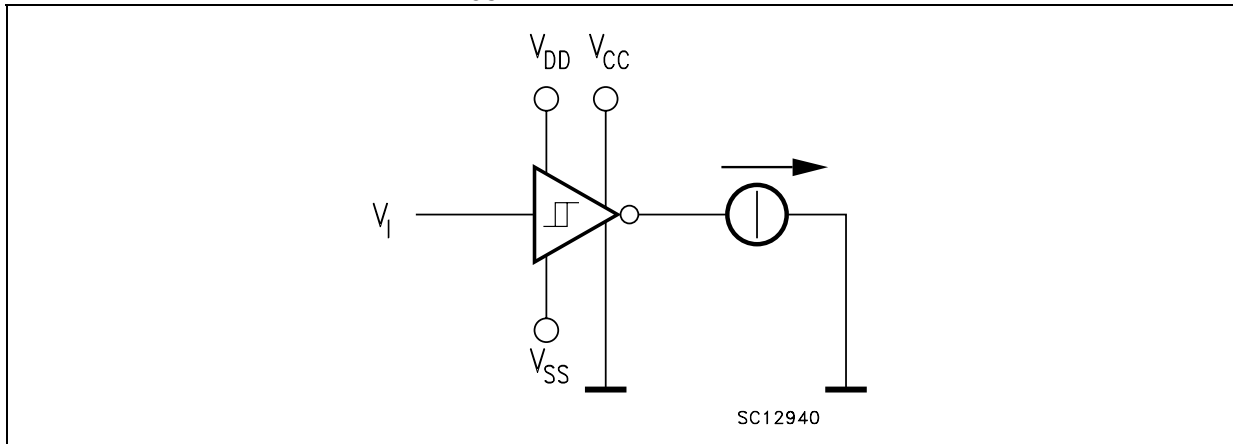

Figure 8. Receiver test circuit for V_T , V_{OH} , V_{OL}

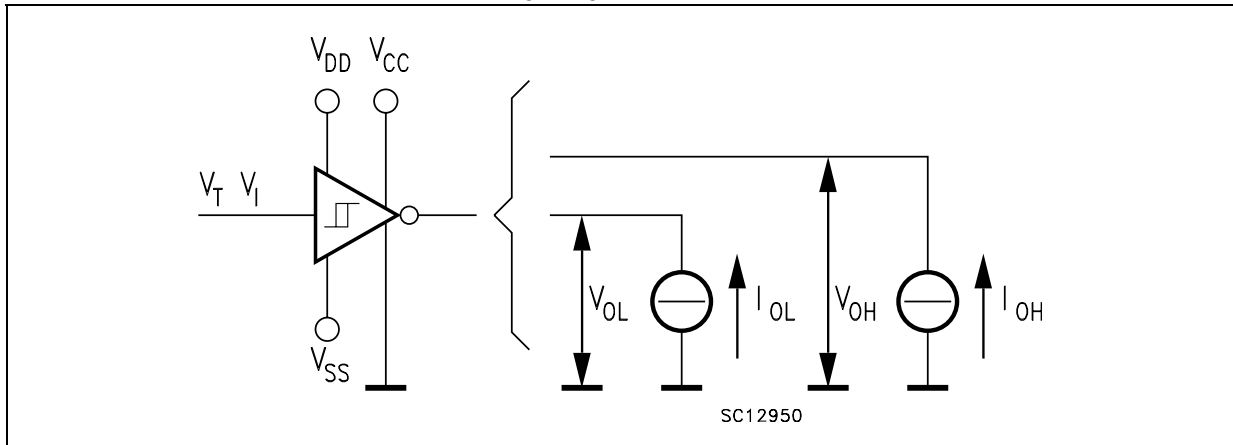

Figure 9. Receiver test circuit

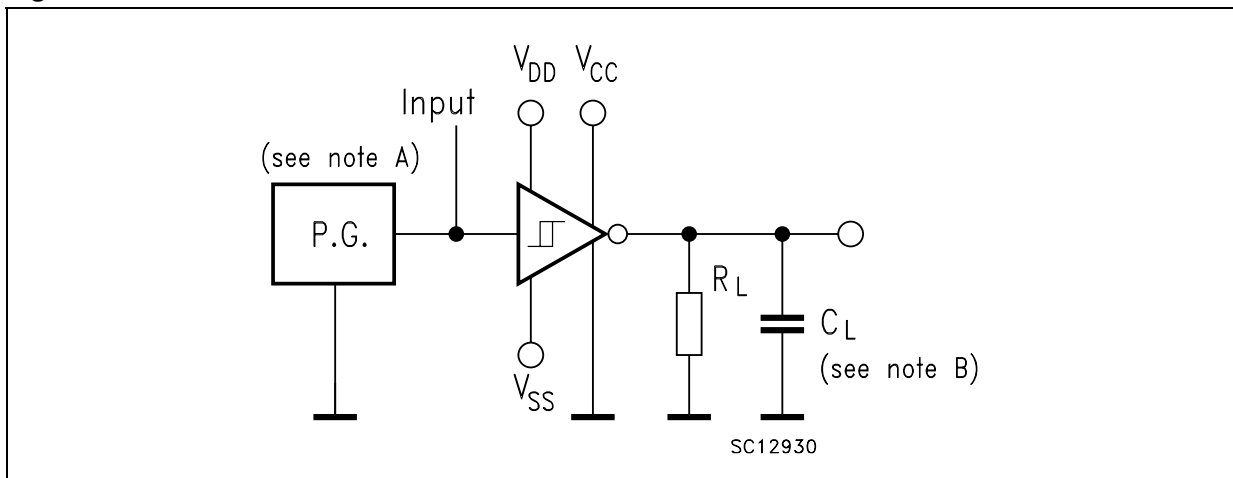
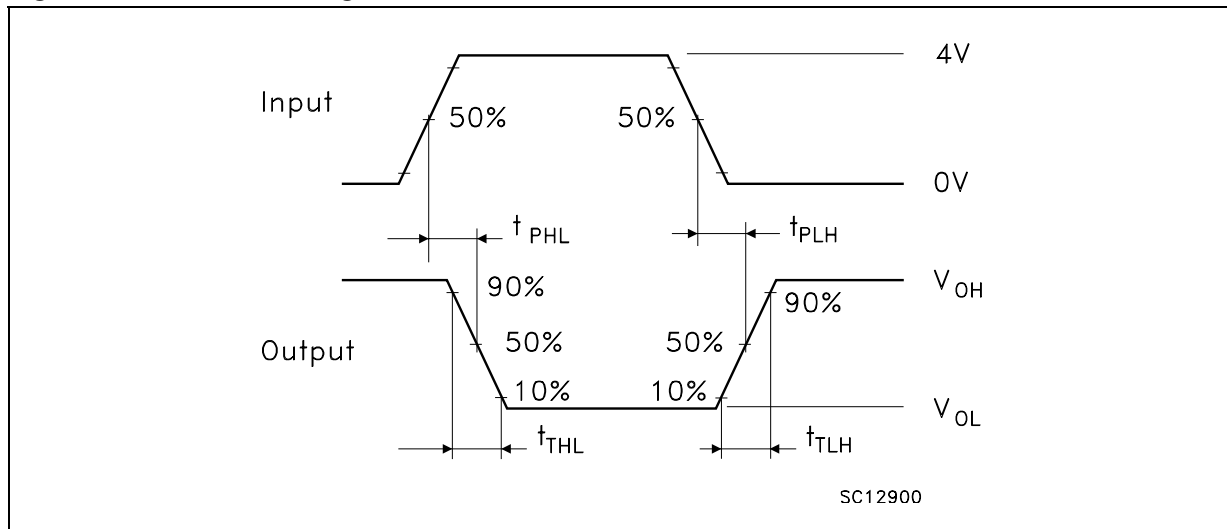

Figure 10. Receiver voltage waveforms



- Note: 1 The pulse generator has the following characteristics: $t_W = 25 \mu s$, $PRR = 20 \text{ kHz}$, $Z_O = 50 \Omega$, $t_r = t_f < 50 \text{ ns}$
- 2 C_L includes probe and jig capacitance.

5 Typical characteristics

Figure 11. Driver voltage transfer characteristics

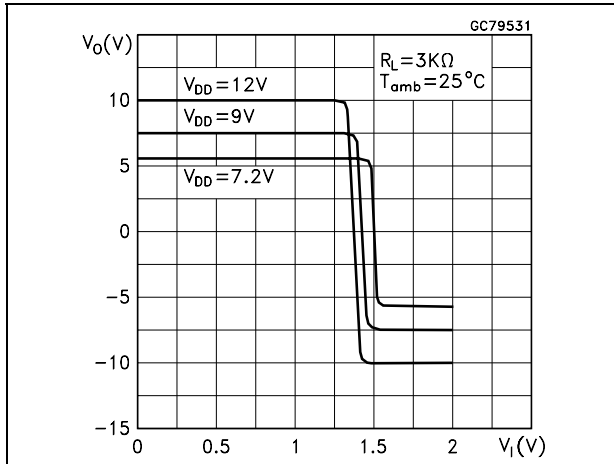

Figure 12. Driver short circuit output current vs. free-air temperature

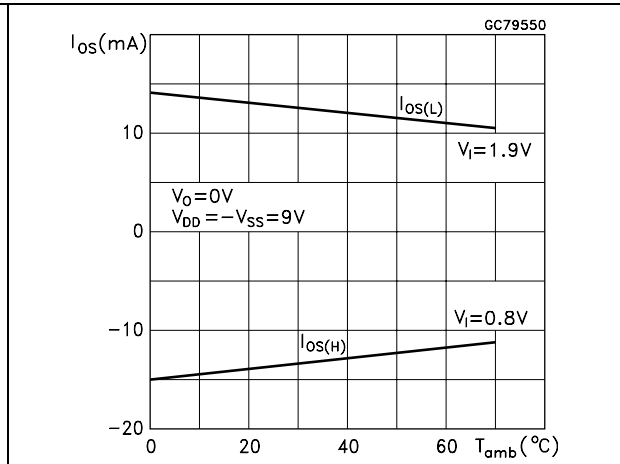

Figure 13. Device supply current vs. temperature

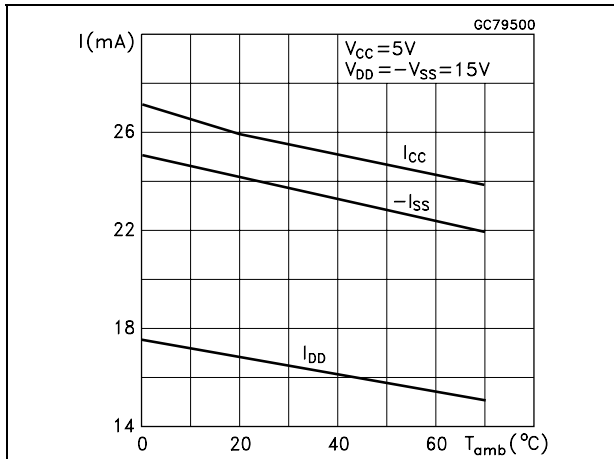

Figure 14. Driver output current vs. output voltage

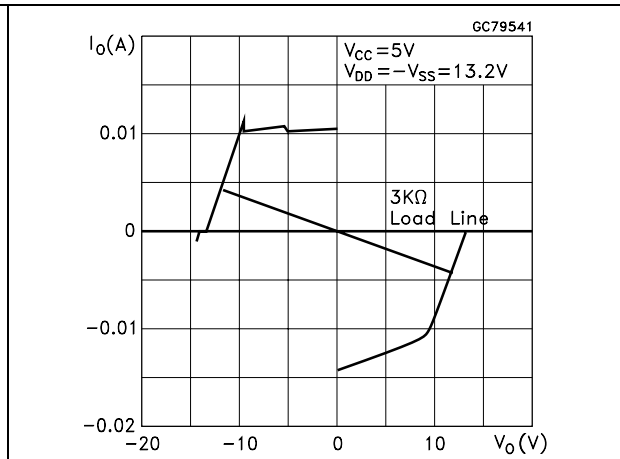

Figure 15. Driver output slew rate vs. load capacitance

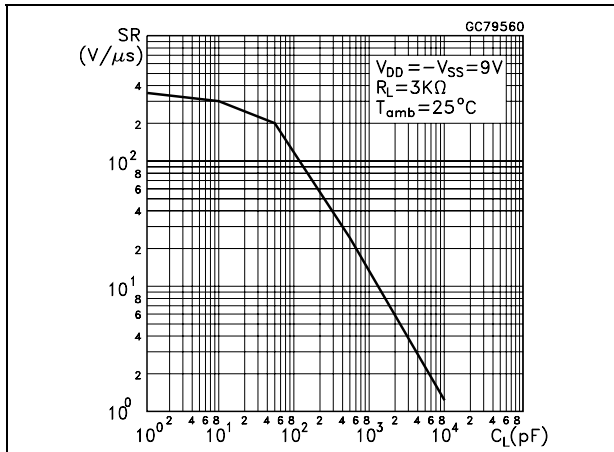

Figure 16. Receiver threshold vs. temperature

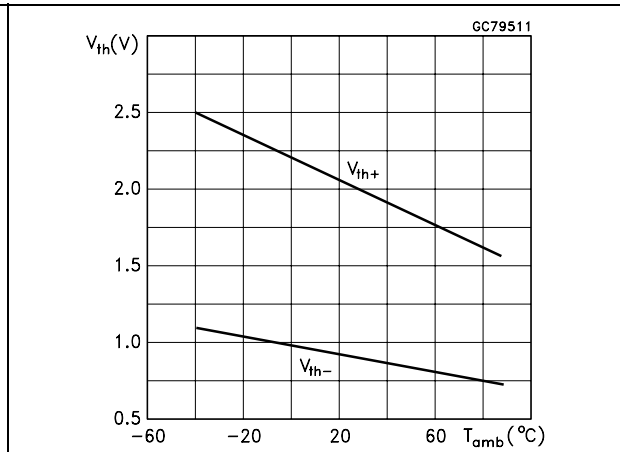
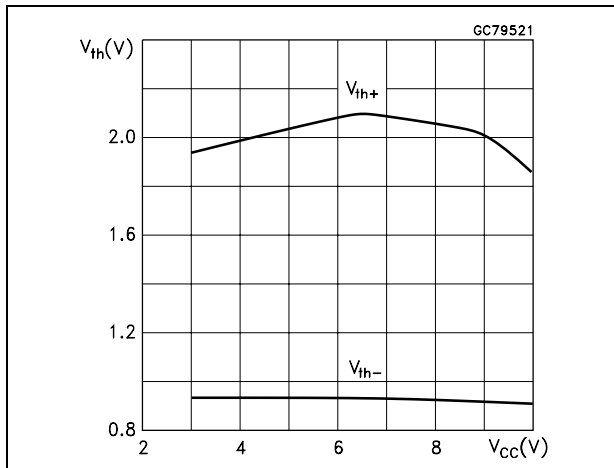

Figure 17. Receiver threshold vs. supply voltage



6 Application information: diodes on power supply

Diodes placed in series with the V_{DD} and V_{SS} leads protect the ST75185C in the fault condition in which the devices output are shorted to ± 15 V and the power supplies are at low state and provide low-impedance path to ground (see [Figure 18](#)).

Figure 18. Diodes on power supply

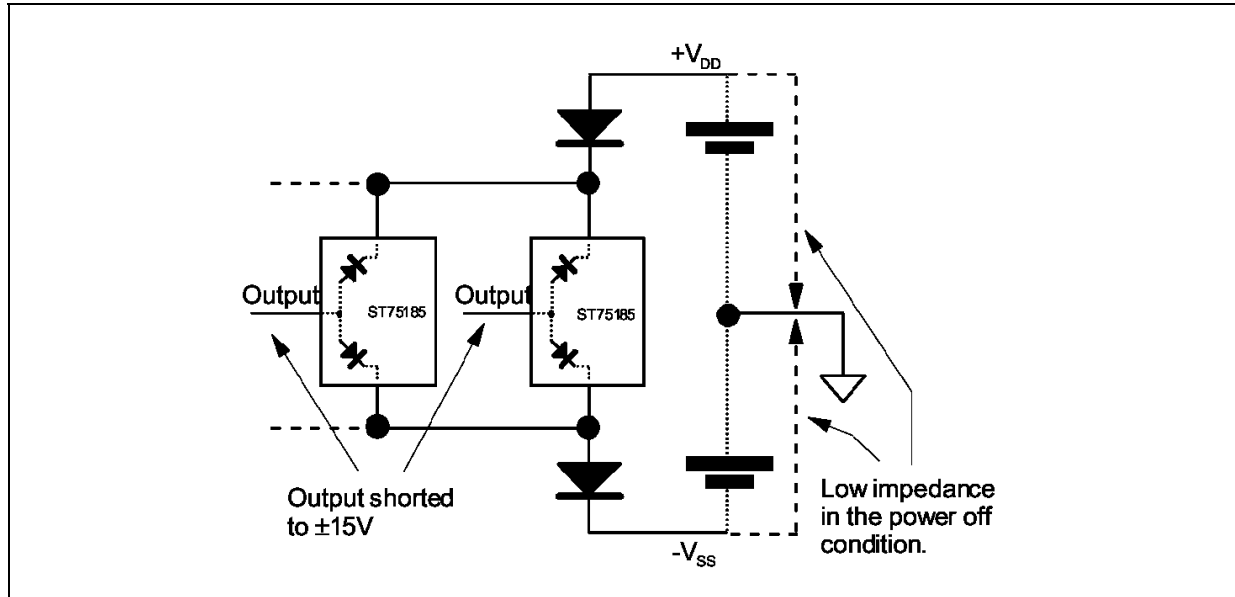

7 Package mechanical data

In order to meet environmental requirements, ST offers these devices in different grades of ECOPACK[®] packages, depending on their level of environmental compliance. ECOPACK[®] specifications, grade definitions and product status are available at: www.st.com. ECOPACK[®] is an ST trademark.

SO-20 mechanical data

Dim.	mm.			inch.		
	Min.	Typ.	Max.	Min.	Typ.	Max.
A	2.35		2.65	0.093		0.104
A1	0.1		0.30	0.004		0.012
B	0.33		0.51	0.013		0.020
C	0.23		0.32	0.009		0.013
D	12.60		13.00	0.496		0.512
E	7.4		7.6	0.291		0.299
e		1.27			0.050	
H	10.00		10.65	0.394		0.419
h	0.25		0.75	0.010		0.030
L	0.4		1.27	0.016		0.050
k	0°		8°	0°		8°
ddd			0.100			0.004

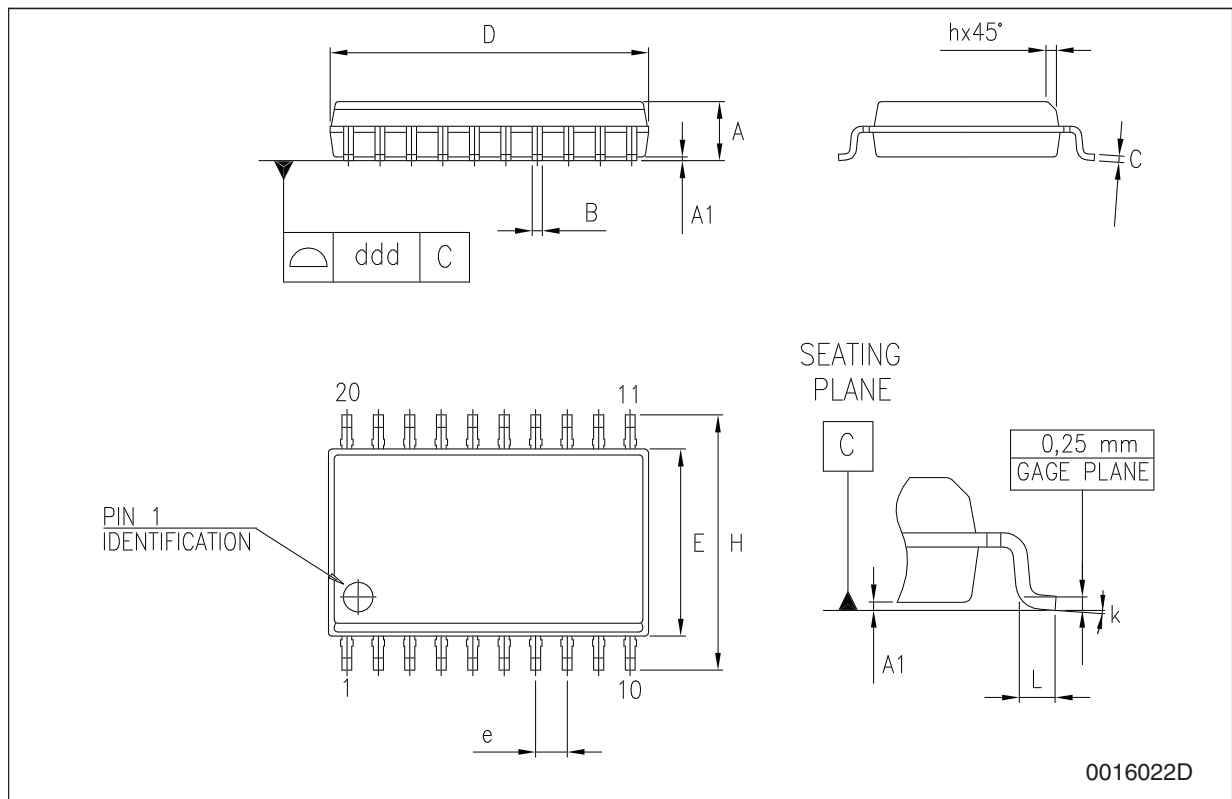

TSSOP20 mechanical data

Dim.	mm.			inch.		
	Min.	Typ.	Max.	Min.	Typ.	Max.
A			1.2			0.047
A1	0.05		0.15	0.002	0.004	0.006
A2	0.8	1	1.05	0.031	0.039	0.041
b	0.19		0.30	0.007		0.012
c	0.09		0.20	0.004		0.0079
D	6.4	6.5	6.6	0.252	0.256	0.260
E	6.2	6.4	6.6	0.244	0.252	0.260
E1	4.3	4.4	4.48	0.169	0.173	0.176
e		0.65 BSC			0.0256 BSC	
K	0°		8°	0°		8°
L	0.45	0.60	0.75	0.018	0.024	0.030

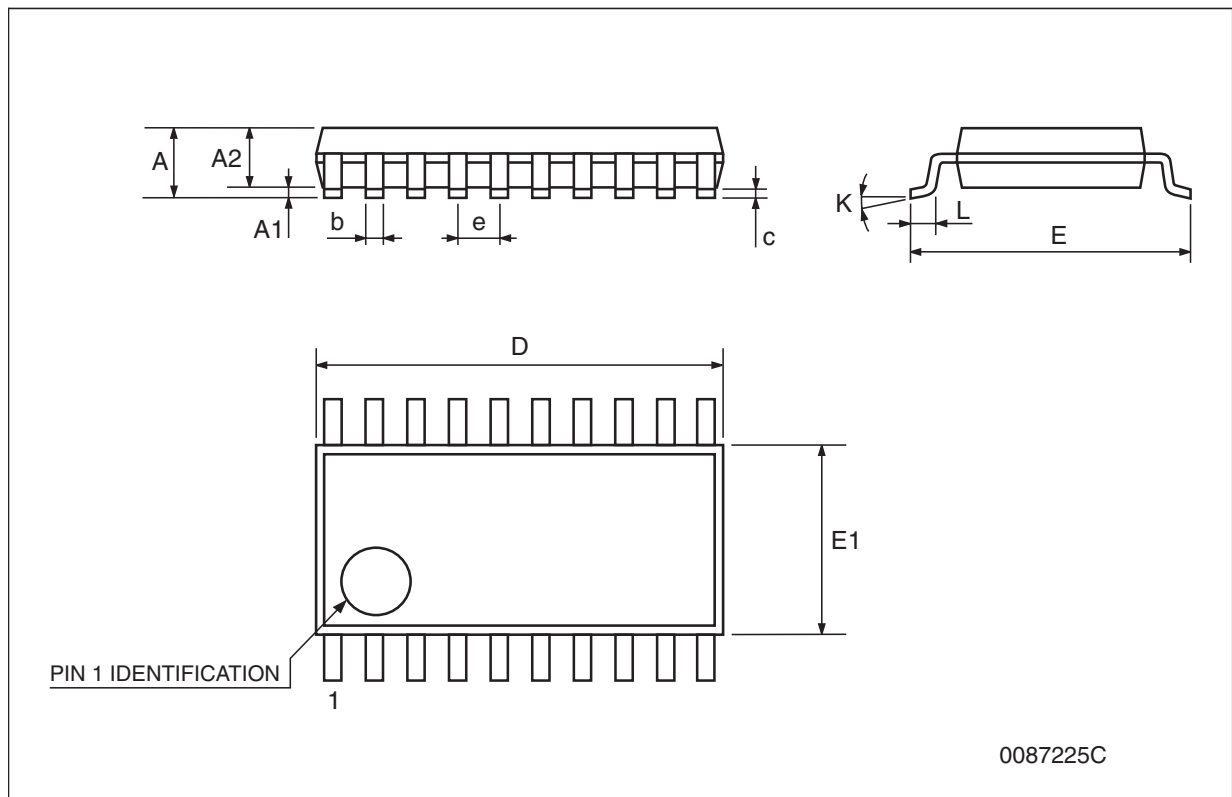

Tape & reel SO-20 mechanical data

Dim.	mm.			inch.		
	Min.	Typ.	Max.	Min.	Typ.	Max.
A			330			12.992
C	12.8		13.2	0.504		0.519
D	20.2			0.795		
N	60			2.362		
T			30.4			1.197
Ao	10.8		11	0.425		0.433
Bo	13.2		13.4	0.520		0.528
Ko	3.1		3.3	0.122		0.130
Po	3.9		4.1	0.153		0.161
P	11.9		12.1	0.468		0.476

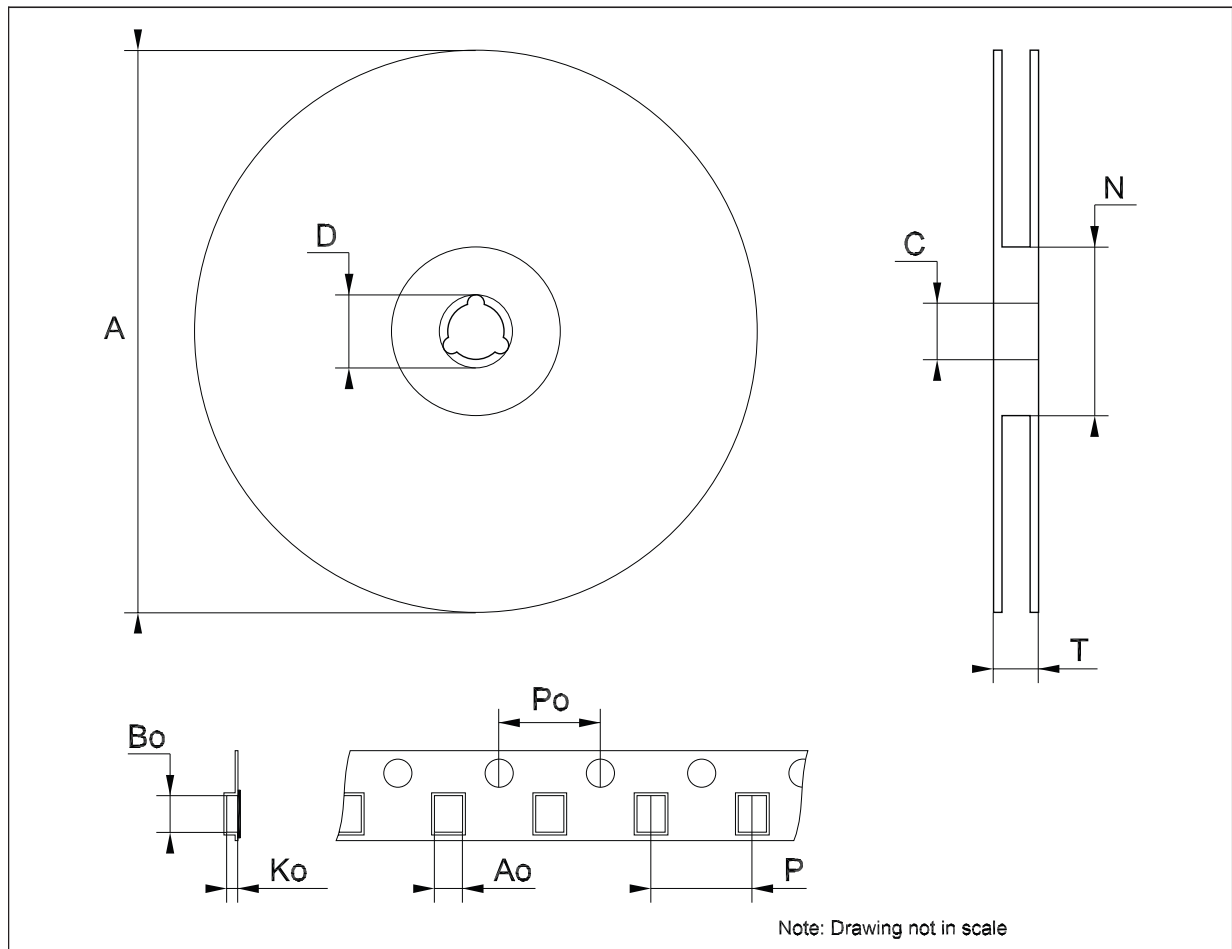

Tape & reel TSSOP20 mechanical data

Dim.	mm.			inch.		
	Min.	Typ.	Max.	Min.	Typ.	Max.
A			330			12.992
C	12.8		13.2	0.504		0.519
D	20.2			0.795		
N	60			2.362		
T			22.4			0.882
Ao	6.8		7	0.268		0.276
Bo	6.9		7.1	0.272		0.280
Ko	1.7		1.9	0.067		0.075
Po	3.9		4.1	0.153		0.161
P	11.9		12.1	0.468		0.476

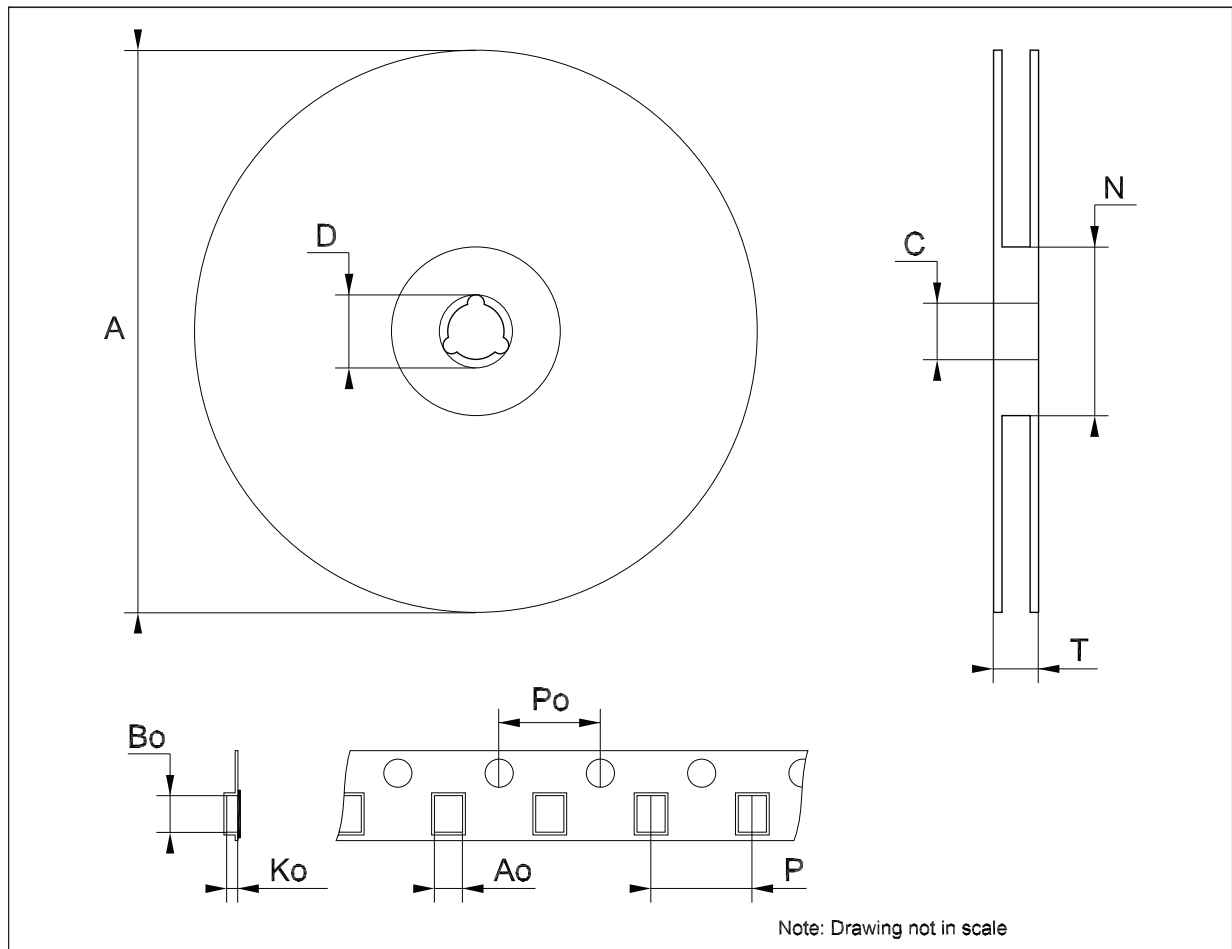

8 Revision history

Table 12. Document revision history

Date	Revision	Changes
28-Apr-2006	15	Order codes updated.
01-Jun-2006	16	Modified: <i>Figure 2</i> .
19-Dec-2007	17	Added: <i>Table 5</i> .
07-Apr-2009	18	Modified <i>Table 5 on page 4</i> .

Please Read Carefully:

Information in this document is provided solely in connection with ST products. STMicroelectronics NV and its subsidiaries ("ST") reserve the right to make changes, corrections, modifications or improvements, to this document, and the products and services described herein at any time, without notice.

All ST products are sold pursuant to ST's terms and conditions of sale.

Purchasers are solely responsible for the choice, selection and use of the ST products and services described herein, and ST assumes no liability whatsoever relating to the choice, selection or use of the ST products and services described herein.

No license, express or implied, by estoppel or otherwise, to any intellectual property rights is granted under this document. If any part of this document refers to any third party products or services it shall not be deemed a license grant by ST for the use of such third party products or services, or any intellectual property contained therein or considered as a warranty covering the use in any manner whatsoever of such third party products or services or any intellectual property contained therein.

UNLESS OTHERWISE SET FORTH IN ST'S TERMS AND CONDITIONS OF SALE ST DISCLAIMS ANY EXPRESS OR IMPLIED WARRANTY WITH RESPECT TO THE USE AND/OR SALE OF ST PRODUCTS INCLUDING WITHOUT LIMITATION IMPLIED WARRANTIES OF MERCHANTABILITY, FITNESS FOR A PARTICULAR PURPOSE (AND THEIR EQUIVALENTS UNDER THE LAWS OF ANY JURISDICTION), OR INFRINGEMENT OF ANY PATENT, COPYRIGHT OR OTHER INTELLECTUAL PROPERTY RIGHT.

UNLESS EXPRESSLY APPROVED IN WRITING BY AN AUTHORIZED ST REPRESENTATIVE, ST PRODUCTS ARE NOT RECOMMENDED, AUTHORIZED OR WARRANTED FOR USE IN MILITARY, AIR CRAFT, SPACE, LIFE SAVING, OR LIFE SUSTAINING APPLICATIONS, NOR IN PRODUCTS OR SYSTEMS WHERE FAILURE OR MALFUNCTION MAY RESULT IN PERSONAL INJURY, DEATH, OR SEVERE PROPERTY OR ENVIRONMENTAL DAMAGE. ST PRODUCTS WHICH ARE NOT SPECIFIED AS "AUTOMOTIVE GRADE" MAY ONLY BE USED IN AUTOMOTIVE APPLICATIONS AT USER'S OWN RISK.

Resale of ST products with provisions different from the statements and/or technical features set forth in this document shall immediately void any warranty granted by ST for the ST product or service described herein and shall not create or extend in any manner whatsoever, any liability of ST.

ST and the ST logo are trademarks or registered trademarks of ST in various countries.

Information in this document supersedes and replaces all information previously supplied.

The ST logo is a registered trademark of STMicroelectronics. All other names are the property of their respective owners.

© 2009 STMicroelectronics - All rights reserved

STMicroelectronics group of companies

Australia - Belgium - Brazil - Canada - China - Czech Republic - Finland - France - Germany - Hong Kong - India - Israel - Italy - Japan - Malaysia - Malta - Morocco - Philippines - Singapore - Spain - Sweden - Switzerland - United Kingdom - United States of America

www.st.com