



# TDE1897R TDE1898R

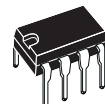
## 0.5A HIGH-SIDE DRIVER INDUSTRIAL INTELLIGENT POWER SWITCH

- 0.5A OUTPUT CURRENT
- 18V TO 35V SUPPLY VOLTAGE RANGE
- INTERNAL CURRENT LIMITING
- THERMAL SHUTDOWN
- OPEN GROUND PROTECTION
- INTERNAL NEGATIVE VOLTAGE CLAMPING TO  $V_s - 45V$  FOR FAST DEMAGNETIZATION
- DIFFERENTIAL INPUTS WITH LARGE COMMON MODE RANGE AND THRESHOLD HYSTERESIS
- UNDERVOLTAGE LOCKOUT WITH HYSTERESIS
- OPEN LOAD DETECTION
- TWO DIAGNOSTIC OUTPUTS
- OUTPUT STATUS LED DRIVER

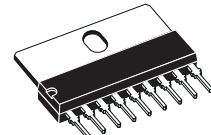
### DESCRIPTION

The TDE1897R/TDE1898R is a monolithic Intelligent Power Switch in Multipower BCD Technol-

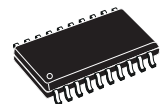
### MULTIPOWER BCD TECHNOLOGY



Minidip



SIP9



SO20

### ORDERING NUMBERS:

TDE1897RDP  
TDE1898RDP

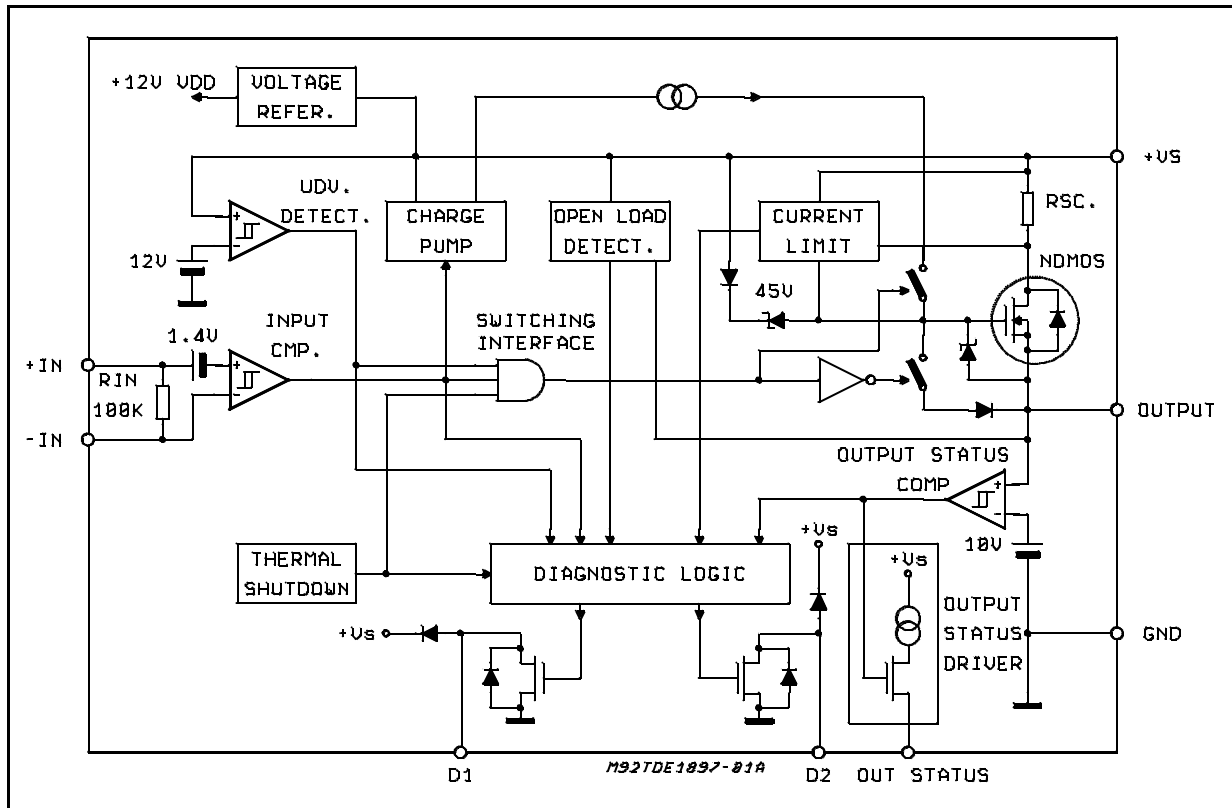
TDE1898RSP

TDE1897RFP  
TDE1898RFP

ogy, for driving inductive or resistive loads. An internal Clamping Diode enables the fast demagnetization of inductive loads.

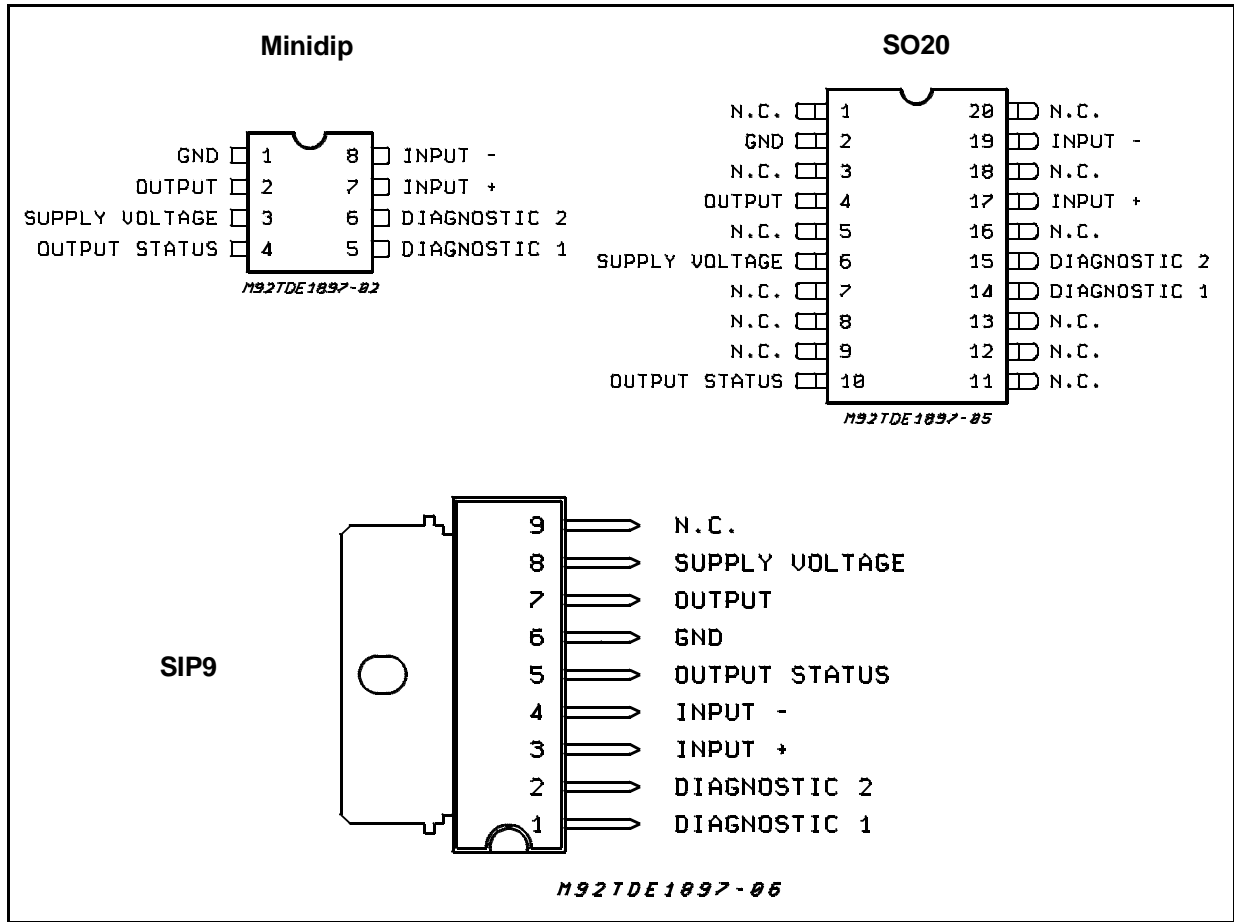
Diagnostic for CPU feedback and extensive use of electrical protections make this device inherently indistructible and suitable for general purpose industrial applications.

### BLOCK DIAGRAM



# TDE1897R - TDE1898R

## PIN CONNECTIONS (Top view)



## ABSOLUTE MAXIMUM RATINGS (Minidip pin reference)

Symbol	Parameter	Value	Unit
$V_S$	Supply Voltage (Pins 3 - 1) ( $T_W < 10ms$ )	50	V
$V_S - V_O$	Supply to Output Differential Voltage. See also $V_{Cl}$ 3-2 (Pins 3 - 2)	internally limited	V
$V_i$	Input Voltage (Pins 7/8)	-10 to $V_S + 10$	V
$V_i$	Differential Input Voltage (Pins 7 - 8)	43	V
$I_i$	Input Current (Pins 7/8)	20	mA
$I_O$	Output Current (Pins 2 - 1). See also ISC	internally limited	A
$E_i$	Energy from Inductive Load ( $T_J = 85^\circ C$ )	200	mJ
$P_{tot}$	Power Dissipation. See also THERMAL CHARACTERISTICS.	internally limited	W
$T_{op}$	Operating Temperature Range ( $T_{amb}$ )	-25 to +85	$^\circ C$
$T_{stg}$	Storage Temperature	-55 to 150	$^\circ C$

## THERMAL DATA

Symbol	Description	Minidip	Sip	SO20	Unit	
$R_{th\ j-case}$	Thermal Resistance Junction-case	Max.	10		$^\circ C/W$	
$R_{th\ j-amb}$	Thermal Resistance Junction-ambient	Max.	100	70	90	$^\circ C/W$

**ELECTRICAL CHARACTERISTICS** ( $V_S = 24V$ ;  $T_{amb} = -25$  to  $+85^\circ C$ , unless otherwise specified)

Symbol	Parameter	Test Condition	Min.	Typ.	Max.	Unit
$V_{smin}$ 3	Supply Voltage for Valid Diagnostics	$I_{diag} > 0.5mA$ @ $V_{dgl} = 1.5V$	9		35	V
$V_S$ 3	Supply Voltage (operative)		18	24	35	V
$I_q$ 3	Quiescent Current $I_{out} = I_{os} = 0$	$V_{il}$ $V_{ih}$		2.5 4.5	4 7.5	mA mA
$V_{sth1}$	Undervoltage Threshold 1	(See fig. 1); $T_{amb} = 0$ to $+85^\circ C$	11			V
$V_{sth2}$ 3	Undervoltage Threshold 2	(See fig. 1); $T_{amb} = 0$ to $+85^\circ C$			15.5	V
$V_{shys}$	Supply Voltage Hysteresis	(See fig. 1); $T_{amb} = 0$ to $+85^\circ C$	0.4	1	3	V
$I_{sc}$	Short Circuit Current	$V_S = 18$ to $35V$ ; $R_L = 1\Omega$	0.75		1.5	A
$V_{don}$ 3-2	Output Voltage Drop	@ $I_{out} = 625mA$ ; $T_j = 25^\circ C$ @ $I_{out} = 625mA$ ; $T_j = 125^\circ C$		250 400	425 600	mV mV
$I_{oslk}$ 2	Output Leakage Current	@ $V_i = V_{il}$ , $V_o = 0V$			300	$\mu A$
$V_{ol}$ 2	Low State Out Voltage	@ $V_i = V_{ih}$ ; $R_L = \infty$		0.8	1.5	V
$V_{cl}$ 3-2	Internal Voltage Clamp ( $V_S - V_O$ )	@ $I_O = -500mA$	45		55	V
$I_{old}$ 2	Open Load Detection Current	$V_i = V_{ih}$ ; $T_{amb} = 0$ to $+85^\circ C$	0.5		9.5	mA
$V_{id}$ 7-8	Common Mode Input Voltage Range (Operative)	$V_S = 18$ to $35V$ , $V_S - V_{id}$ 7-8 < $37V$	-7		15	V
$I_{ib}$ 7-8	Input Bias Current	$V_i = -7$ to $15V$ ; $-In = 0V$	-700		700	$\mu A$
$V_{ith}$ 7-8	Input Threshold Voltage	$V+In > V-In$	0.8	1.4	2	V
$V_{iths}$ 7-8	Input Threshold Hysteresis Voltage	$V+In > V-In$	50		400	mV
$R_{id}$ 7-8	Diff. Input Resistance	@ $0 < +In < +16V$ ; $-In = 0V$ @ $-7 < +In < 0V$ ; $-In = 0V$		400 150		K $\Omega$ K $\Omega$
$I_{ilk}$ 7-8	Input Offset Current	$V+In = V-In$ +li      -20 $0V < V_i < 5.5V$ -li      -75	-20	-25	+20	$\mu A$ $\mu A$
		$-In = GND$ +li      +10 $0V < V+In < 5.5V$ -li      -125	-250	-125	+50	$\mu A$ $\mu A$
		$+In = GND$ +li      -100 $0V < V-In < 5.5V$ -li      -50	-100	-30	-15	$\mu A$ $\mu A$
$V_{oth1}$ 2	Output Status Threshold 1 Voltage	(See fig. 1)			12	V
$V_{oth2}$ 2	Output Status Threshold 2 Voltage	(See fig. 1)	9			V
$V_{ohys}$ 2	Output Status Threshold Hysteresis	(See fig. 1)	0.3	0.7	2	V
$I_{osd}$ 4	Output Status Source Current	$V_{out} > V_{oth1}$ , $V_{os} = 2.5V$	2		4	mA
$V_{osd}$ 3-4	Active Output Status Driver Drop Voltage	$V_S - V_{os}$ @ $I_{os} = 2mA$ ; $T_{amb} = -25$ to $85^\circ C$			5	V
$I_{oslk}$ 4	Output Status Driver Leakage Current	$V_{out} < V_{oth2}$ , $V_{os} = 0V$ $V_S = 18$ to $35V$			25	$\mu A$
$V_{dgl}$ 5/6	Diagnostic Drop Voltage	$D1 / D2 = L$ @ $I_{diag} = 0.5mA$			250	mV
		$D1 / D2 = L$ @ $I_{diag} = 3mA$			1.5	V
$I_{dglk}$ 5/6	Diagnostic Leakage Current	$D1 / D2 = H$ @ $0 < V_{dg} < V_S$ $V_S = 15.6$ to $35V$			25	$\mu A$
$V_{rdg}$ 5/6-3	Clamping Diodes at the Diagnostic Outputs. Voltage Drop to $V_S$	@ $I_{diag} = 5mA$ ; $D1 / D2 = H$			2	V

**Note**  $V_{il} \leq 0.8V$ ,  $V_{ih} \geq 2V$  @ ( $V+In > V-In$ ); Minidip pin reference.  
All test not dissipative.

## TDE1897R - TDE1898R

### SOURCE DRAIN NDMOS DIODE

Symbol	Parameter	Test Condition	Min.	Typ.	Max.	Unit
$V_{fsd}$ 2-3	Forward On Voltage	@ $I_{fsd} = 625\text{mA}$		1	1.5	V
$I_{fp}$ 2-3	Forward Peak Current	$t = 10\text{ms}; d = 20\%$			2	A
$t_{rr}$ 2-3	Reverse Recovery Time	$I_f = 625\text{mA}$ $di/dt = 25\text{A}/\mu\text{s}$		200		ns
$t_{fr}$ 2-3	Forward Recovery Time			50		ns

### THERMAL CHARACTERISTICS (\*)

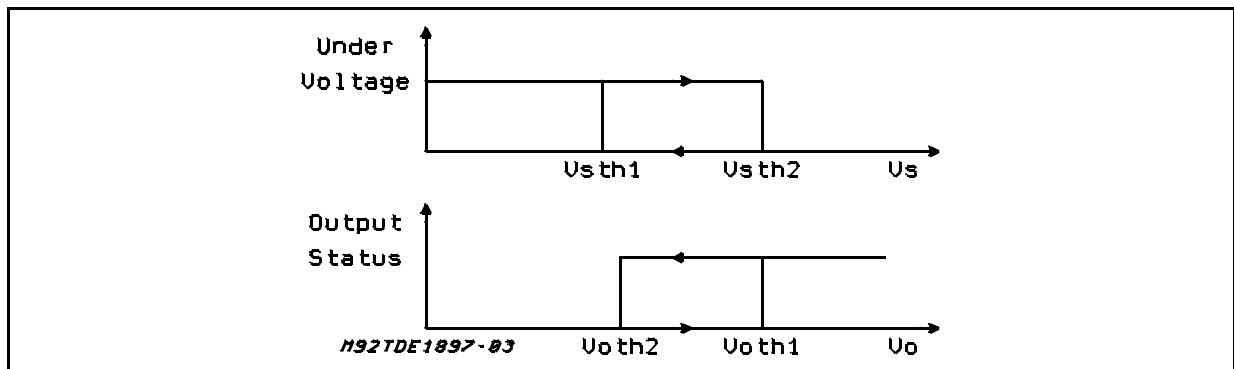
$\Theta$ Lim	Junction Temp. Protect.		135	150		°C
$T_H$	Thermal Hysteresis			30		°C

### SWITCHING CHARACTERISTICS ( $V_S = 24\text{V}; R_L = 48\Omega$ ) (\*)

$t_{on}$	Turn on Delay Time				100	$\mu\text{s}$
$t_{off}$	Turn off Delay Time				20	$\mu\text{s}$
$t_d$	Input Switching to Diagnostic Valid				100	$\mu\text{s}$

Note  $V_{il} \leq 0.8\text{V}$ ,  $V_{ih} \geq 2\text{V}$  @ ( $V_{+In} > V_{-In}$ ); Minidip pin reference. (\*) Not tested.

Figure 1



### DIAGNOSTIC TRUTH TABLE

Diagnostic Conditions	Input	Output	Diag1	Diag2
Normal Operation	L H	L H	H H	H H
Open Load Condition ( $I_o < I_{oid}$ )	L H	L H	H L	H H
Short to $V_S$	L H	H H	L L	H H
Short Circuit to Ground ( $I_o = I_{sc}$ ) (**)	<b>TDE1897R</b>	H	<H (*)	H L
	<b>TDE1898R</b>	H	H L	H H
Output DMOS Open	L H	L L	H L	H H
Overtemperature	L H	L L	H H	L L
Supply Undervoltage ( $V_S < V_{sth1}$ in the falling phase of the supply voltage; $V_S < V_{sth2}$ in the rising phase of the supply voltage)	L H	L L	L L	L L

(\*) According to the intervention of the current limiting block.

(\*\*) A cold lamp filament, or a capacitive load may activate the current limiting circuit of the IPS, when the IPS is initially turned on. TDE1897 uses Diag2 to signal such condition, TDE1898 does not.

**APPLICATION INFORMATION**

**DEMAGNETIZATION OF INDUCTIVE LOADS**

An internal zener diode, limiting the voltage across the Power MOS to between 45 and 55V (V<sub>cl</sub>), provides safe and fast demagnetization of inductive loads without external clamping devices.

The maximum energy that can be absorbed from an inductive load is specified as 200mJ (at T<sub>j</sub> = 85°C).

To define the maximum switching frequency three points have to be considered:

- 1) The total power dissipation is the sum of the On State Power and of the Demagnetization Energy multiplied by the frequency.
- 2) The total energy W dissipated in the device during a demagnetization cycle (fig. 2, 3) is:

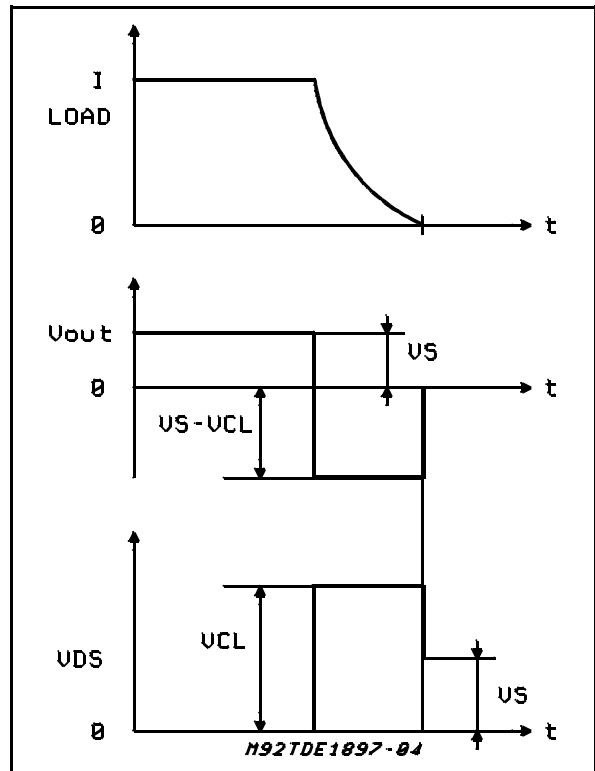
$$W = V_{cl} \frac{L}{R_L} \left[ I_o - \frac{V_{cl} - V_s}{R_L} \log \left( 1 + \frac{V_s}{V_{cl} - V_s} \right) \right]$$

Where:

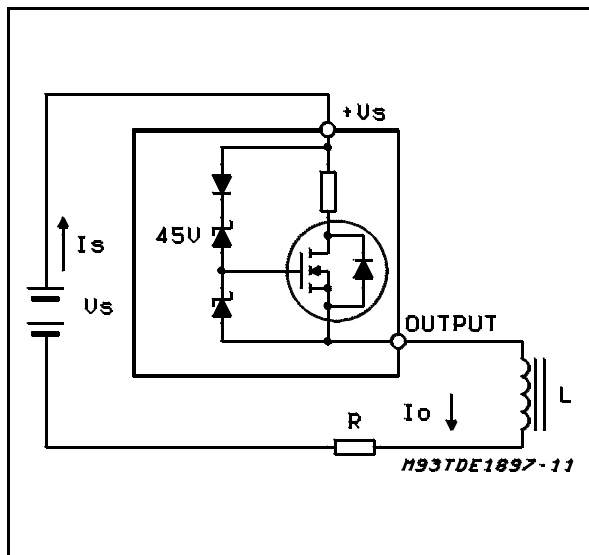
- V<sub>cl</sub> = clamp voltage;
- L = inductive load;
- R<sub>L</sub> = resistive load;
- V<sub>s</sub> = supply voltage;
- I<sub>o</sub> = I<sub>LOAD</sub>

- 3) In normal conditions the operating Junction temperature should remain below 125°C.

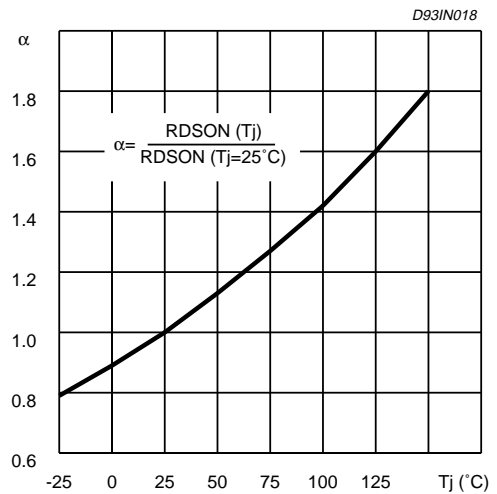
**Figure 3: Demagnetization Cycle Waveforms**



**Figure 2: Inductive Load Equivalent Circuit**



**Figure 4: Normalized R<sub>DS(on)</sub> vs. Junction Temperature**



**WORST CONDITION POWER DISSIPATION IN THE ON-STATE**

In IPS applications the maximum average power dissipation occurs when the device stays for a long time in the ON state. In such a situation the internal temperature depends on delivered current (and related power), thermal characteristics of the package and ambient temperature.

At ambient temperature close to upper limit (+85°C) and in the worst operating conditions, it is possible that the chip temperature could increase so much to make the thermal shutdown procedure untimely intervene.

Our aim is to find the maximum current the IPS can withstand in the ON state without thermal shutdown intervention, related to ambient temperature. To this end, we should consider the following points:

- 1) The ON resistance  $R_{DSON}$  of the output NDMOS (the real switch) of the device increases with its temperature. Experimental results show that silicon resistivity increases with temperature at a constant rate, rising of 60% from 25°C to 125°C. The relationship between  $R_{DSON}$  and temperature is therefore:

$$R_{DSON} = R_{DSON0} (1 + k) (T_j - 25)$$

where:

- $T_j$  is the silicon temperature in °C
- $R_{DSON0}$  is  $R_{DSON}$  at  $T_j=25^\circ\text{C}$
- $k$  is the constant rate ( $k = 4.711 \cdot 10^{-3}$ ) (see fig. 4).

- 2) In the ON state the power dissipated in the device is due to three contributes:
  - a) power lost in the switch:  
 $P_{out} = I_{out}^2 \cdot R_{DSON}$  ( $I_{out}$  is the output current);
  - b) power due to quiescent current in the ON state  $I_q$ , sunk by the device in addition to  $I_{out}$ :  $P_q = I_q \cdot V_s$  ( $V_s$  is the supply voltage);
  - c) an external LED could be used to visualize the switch state (OUTPUT STATUS pin). Such a LED is driven by an internal current source (delivering  $I_{os}$ ) and therefore, if  $V_{os}$  is the voltage drop across the LED, the dissipated power is:  $P_{os} = I_{os} \cdot (V_s - V_{os})$ .

Thus the total ON state power consumption is given by:

$$P_{on} = P_{out} + P_q + P_{os} \quad (1)$$

In the right side of equation 1, the second and

the third element are constant, while the first one increases with temperature because  $R_{DSON}$  increases as well.

- 3) The chip temperature must not exceed  $\Theta_{Lim}$  in order do not lose the control of the device. The heat dissipation path is represented by the thermal resistance of the system device-board-ambient ( $R_{th}$ ). In steady state conditions, this parameter relates the power dissipated  $P_{on}$  to the silicon temperature  $T_j$  and the ambient temperature  $T_{amb}$ :

$$T_j - T_{amb} = P_{on} \cdot R_{th} \quad (2)$$

From this relationship, the maximum power  $P_{on}$  which can be dissipated without exceeding  $\Theta_{Lim}$  at a given ambient temperature  $T_{amb}$  is:

$$P_{on} = \frac{\Theta_{Lim} - T_{amb}}{R_{th}}$$

Replacing the expression (1) in this equation and solving for  $I_{out}$ , we can find the maximum current versus ambient temperature relationship:

$$I_{outx} = \sqrt{\frac{\frac{\Theta_{Lim} - T_{amb}}{R_{th}} - P_q - P_{os}}{R_{DSONx}}}$$

where  $R_{DSONx}$  is  $R_{DSON}$  at  $T_j=\Theta_{Lim}$ . Of course,  $I_{outx}$  values are top limited by the maximum operative current  $I_{outx}$  (500mA nominal).

From the expression (2) we can also find the maximum ambient temperature  $T_{amb}$  at which a given power  $P_{on}$  can be dissipated:

$$T_{amb} = \Theta_{Lim} - P_{on} \cdot R_{th} = \Theta_{Lim} - (I_{out}^2 \cdot R_{DSONx} + P_q + P_{os}) \cdot R_{th}$$

In particular, this relation is useful to find the maximum ambient temperature  $T_{ambx}$  at which  $I_{outx}$  can be delivered:

$$T_{ambx} = \Theta_{Lim} - (I_{outx}^2 \cdot R_{DSONx} + P_q + P_{os}) \cdot R_{th} \quad (4)$$

Referring to application circuit in fig. 5, let us consider the worst case:

- The supply voltage is at maximum value of industrial bus (30V instead of the 24V nominal value). This means also that  $I_{outx}$  rises of 25%

- (625mA instead of 500mA).
- All electrical parameters of the device, concerning the calculation, are at maximum values.
- Thermal shutdown threshold is at minimum value.
- No heat sink nor air circulation ( $R_{th}$  equal to  $R_{thj-amb}$ ).

Therefore:

$V_s = 30V$ ,  $R_{DSOn0} = 0.6\Omega$ ,  $I_q = 6mA$ ,  $I_{os} = 4mA$  @  $V_{os} = 2.5V$ ,  $\Theta_{Lim} = 135^\circ C$

$R_{thj-amb} = 100^\circ C/W$  (Minidip);  $90^\circ C/W$  (SO20);  $70^\circ C/W$  (SIP9)

It follows:

$I_{outx} = 0.625mA$ ,  $R_{DSOnx} = 1.006\Omega$ ,  $P_q = 180mW$ ,  $P_{os} = 110mW$

From equation 4, we can find:

$$T_{ambx} = \begin{matrix} 66.7^\circ C & (\text{Minidip}); \\ 73.5^\circ C & (\text{SO20}); \\ 87.2^\circ C & (\text{SIP9}). \end{matrix}$$

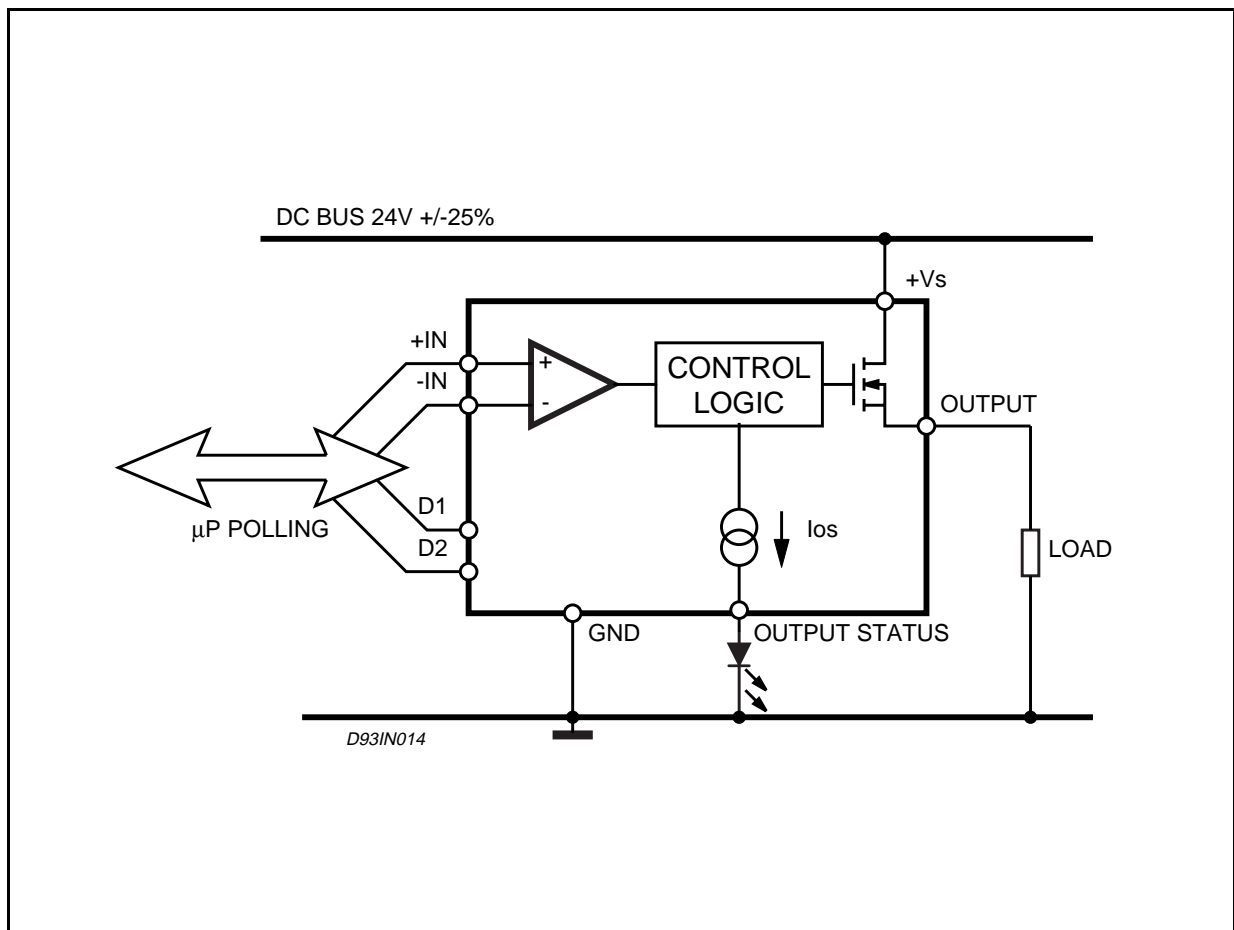
Therefore, the IPS TDE1897/1898, although guaranteed to operate up to  $85^\circ C$  ambient temperature, if used in the worst conditions, can meet some limitations.

SIP9 package, which has the lowest  $R_{thj-amb}$ , can work at maximum operative current over the entire ambient temperature range in the worst conditions too. For other packages, it is necessary to consider some reductions.

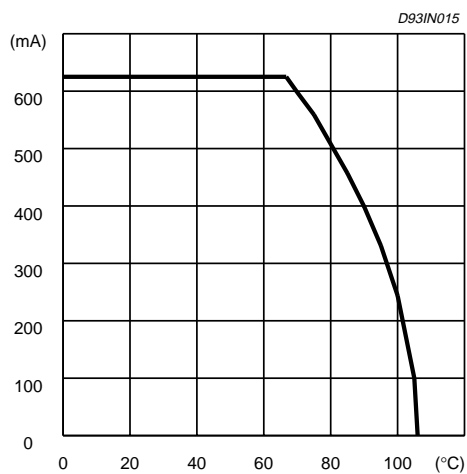
With the aid of equation 3, we can draw a derating curve giving the maximum current allowable versus ambient temperature. The diagrams, computed using parameter values above given, are depicted in figg. 6 to 8.

If an increase of the operating area is needed, heat dissipation must be improved ( $R_{th}$  reduced) e.g. by means of air cooling.

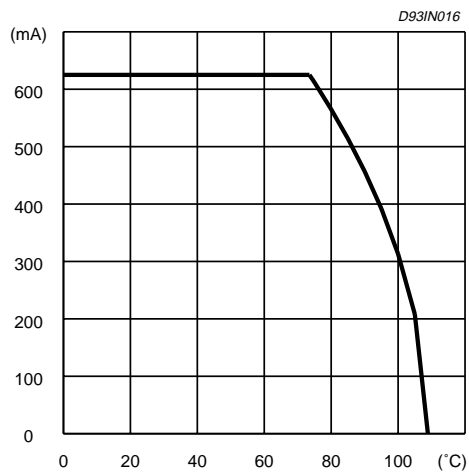
Figure 5: Application Circuit.



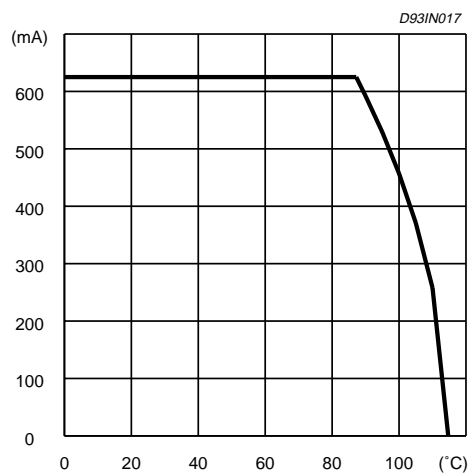
**Figure 6:** Max. Output Current vs. Ambient Temperature (Minidip Package,  $R_{th\ j-amb} = 100^{\circ}C/W$ )



**Figure 7:** Max. Output Current vs. Ambient Temperature (SO20 Package,  $R_{th\ j-amb} = 90^{\circ}C/W$ )

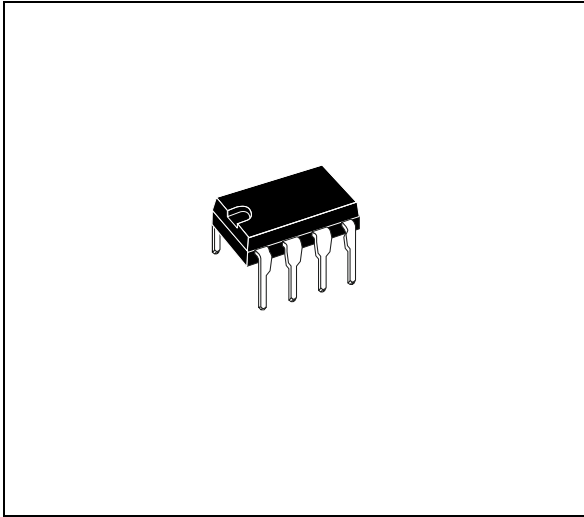


**Figure 8:** Max. Output Current vs. Ambient Temperature (SIP9 Package,  $R_{th\ j-amb} = 70^{\circ}C/W$ )

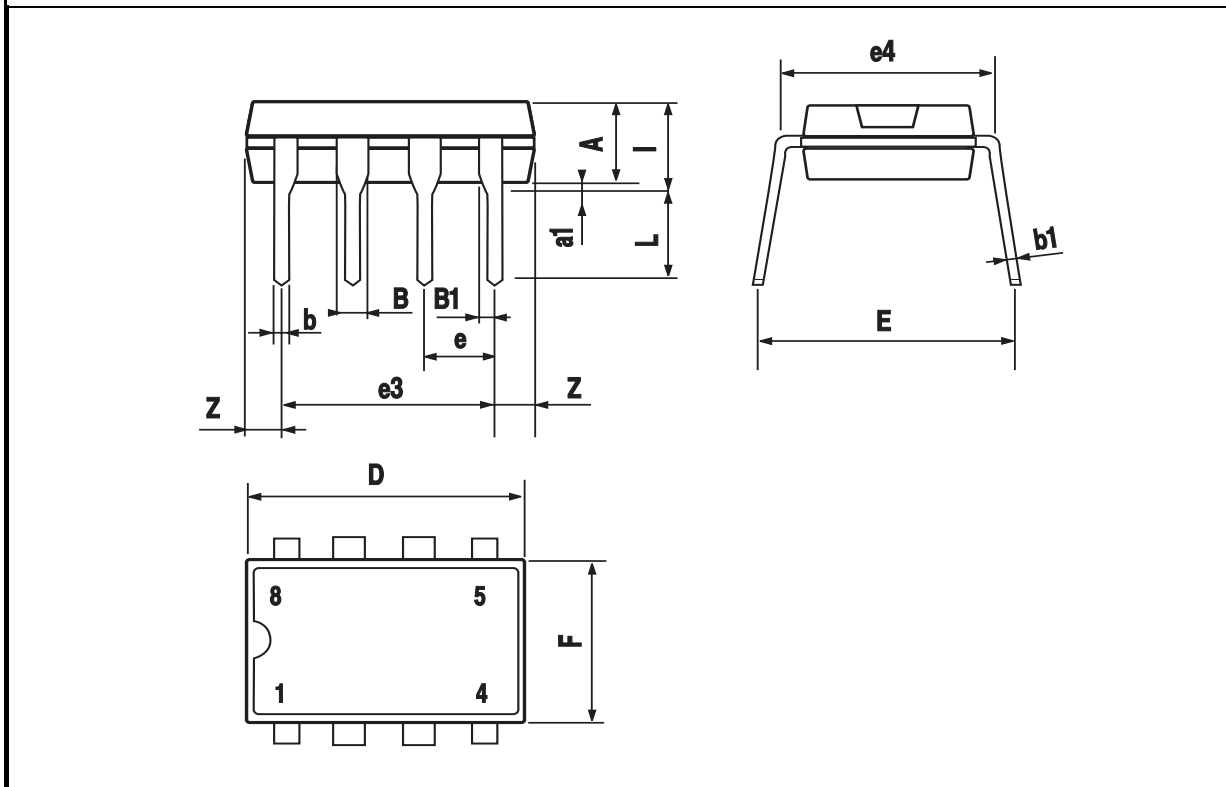


DIM.	mm			inch		
	MIN.	TYP.	MAX.	MIN.	TYP.	MAX.
A		3.32			0.131	
a1	0.51			0.020		
B	1.15		1.65	0.045		0.065
b	0.356		0.55	0.014		0.022
b1	0.204		0.304	0.008		0.012
D			10.92			0.430
E	7.95		9.75	0.313		0.384
e		2.54			0.100	
e3		7.62			0.300	
e4		7.62			0.300	
F			6.6			0.260
I			5.08			0.200
L	3.18		3.81	0.125		0.150
Z			1.52			0.060

**OUTLINE AND MECHANICAL DATA**



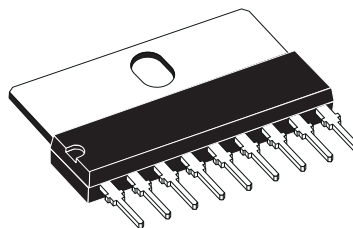
**Minidip**



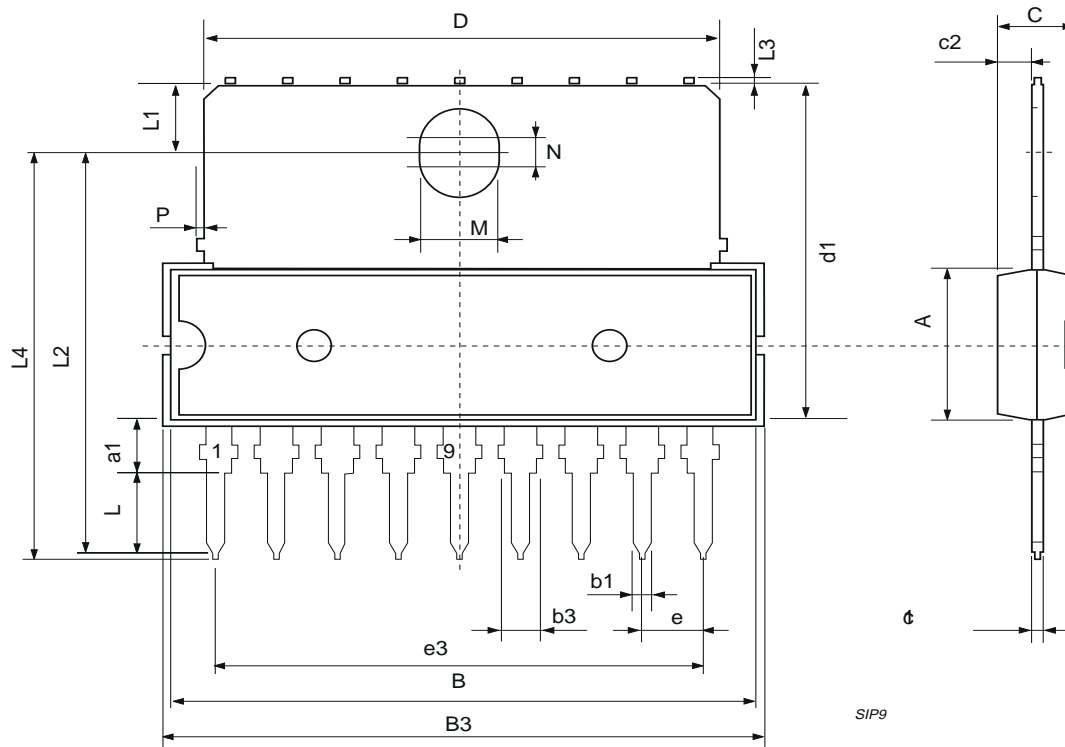
# TDE1897R - TDE1898R

DIM.	mm			inch		
	MIN.	TYP.	MAX.	MIN.	TYP.	MAX.
A			7.1			0.280
a1	2.7		3	0.106		0.118
B			23			0.90
B3			24.8			0.976
b1		0.5			0.020	
b3	0.85		1.6	0.033		0.063
C		3.3			0.130	
c1		0.43			0.017	
c2		1.32			0.052	
D			21.2			0.835
d1		14.5			0.571	
e		2.54			0.100	
e3		20.32			0.800	
L	3.1			0.122		
L1		3			0.118	
L2		17.6			0.693	
L3			0.25			0.010
L4	17.4		17.85	0.685		0.702
M		3.2			0.126	
N		1			0.039	
P			0.15			0.006

## OUTLINE AND MECHANICAL DATA

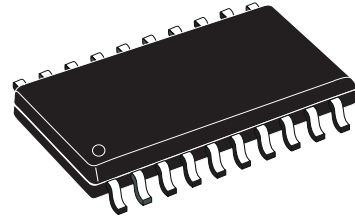


**SIP9**

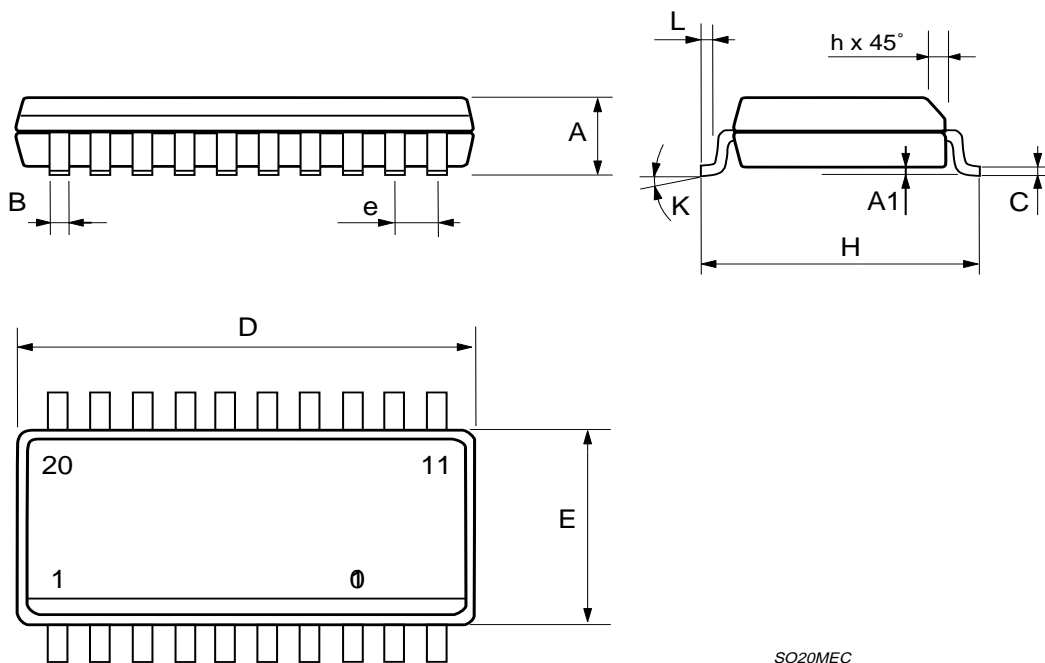


DIM.	mm			inch		
	MIN.	TYP.	MAX.	MIN.	TYP.	MAX.
A	2.35		2.65	0.093		0.104
A1	0.1		0.3	0.004		0.012
B	0.33		0.51	0.013		0.020
C	0.23		0.32	0.009		0.013
D	12.6		13	0.496		0.512
E	7.4		7.6	0.291		0.299
e		1.27			0.050	
H	10		10.65	0.394		0.419
h	0.25		0.75	0.010		0.030
L	0.4		1.27	0.016		0.050
K	0° (min.)8° (max.)					

**OUTLINE AND MECHANICAL DATA**



**SO20**



Information furnished is believed to be accurate and reliable. However, STMicroelectronics assumes no responsibility for the consequences of use of such information nor for any infringement of patents or other rights of third parties which may result from its use. No license is granted by implication or otherwise under any patent or patent rights of STMicroelectronics. Specifications mentioned in this publication are subject to change without notice. This publication supersedes and replaces all information previously supplied. STMicroelectronics products are not authorized for use as critical components in life support devices or systems without express written approval of STMicroelectronics.

The ST logo is a registered trademark of STMicroelectronics.  
All other names are the property of their respective owners

© 2003 STMicroelectronics - All rights reserved

**STMicroelectronics GROUP OF COMPANIES**

Australia - Belgium - Brazil - Canada - China - Czech Republic - Finland - France - Germany - Hong Kong - India - Israel - Italy - Japan -  
Malaysia - Malta - Morocco - Singapore - Spain - Sweden - Switzerland - United Kingdom - United States

[www.st.com](http://www.st.com)