



STM32L151xD, STM32L152xD

Ultralow power ARM-based 32-bit MCU with 384 KB Flash, RTC, LCD, USB, analog functions, 10 serial ports, memory I/F

Datasheet – production data

Features

- Operating conditions
 - Operating power supply range: 1.65 V to 3.6 V (without BOR) or 1.8 V to 3.6 V
- Low power features
 - 7 modes: Sleep, Low-power run (11 μ A at 32 kHz), Low-power sleep (4.4 μ A), Stop with RTC, Stop (650 nA), Standby with RTC, Standby (300 nA)
 - Dynamic core voltage scaling down to 233 μ A/MHz
 - Ultralow leakage per I/O: 50 nA max
 - Fast wakeup time from Stop: 8 μ s
 - Three wakeup pins
- Core: ARM 32-bit Cortex™-M3 CPU
 - 32 MHz maximum frequency, 33.3 DMIPS peak (Dhrystone 2.1)
 - Memory protection unit
- Reset and supply management
 - Low power, ultrasafe BOR (brownout reset)
 - Ultralow power POR/PDR
 - Programmable voltage detector (PVD)
- Clock management
 - 1 to 24 MHz crystal oscillator
 - 32 kHz oscillator for RTC with calibration
 - Internal 16 MHz factory-trimmed RC
 - Internal 37 kHz low consumption RC
 - Internal multispeed low power RC, 65 kHz to 4.2 MHz
 - PLL for CPU clock and USB (48 MHz)
- Memories
 - 384 Kbytes of Flash memory with ECC, split into two banks allowing Read While Write
 - 12 Kbytes of data EEPROM with ECC
 - NVM in 2 banks enabling Read While Write
 - 48 Kbytes of RAM
 - Flexible static memory controller that supports SRAM, PSRAM and NOR Flash

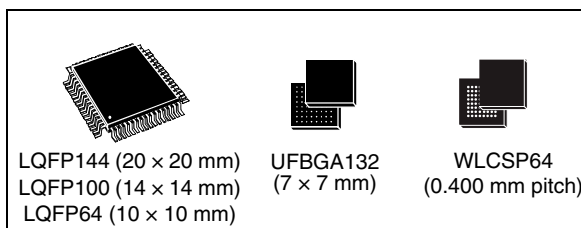

- Low power calendar RTC
 - Alarm, periodic wakeup from Stop/Standby
- Up to 116 fast I/Os (102 of which are 5 V-tolerant)
- DMA: 12-channel DMA controller
- LCD 8 × 40 or 4 × 44 with step-up converter
- 3 operational amplifiers
- 12-bit ADC up to 1 Msps and 40 channels
 - Operational amplifier output, temperature sensor and internal voltage reference
 - Operates down to 1.8 V
- Two 12-bit DACs with output buffers
- Two ultralow power comparators
 - Window mode and wakeup capability
- 11 timers: one 32-bit and six 16-bit general-purpose timers, two 16-bit basic timers, two watchdog timers (independent and window)
- Up to 12 communication interfaces
 - Up to two I2C interfaces (SMBus/PMBus)
 - Up to five USARTs
 - Up to three SPIs (16 Mbit/s), two with I2S
 - USB 2.0 full-speed interface
 - SDIO interface
- Up to 34 capacitive sensing channels supporting touchkey, proximity, linear and rotary sensors
- 32-bit CRC calculation unit, 96-bit unique ID

Table 1. Device summary

Reference	Part number
STM32L151xx	STM32L151QD STM32L151RD STM32L151VD STM32L151ZD
STM32L152xx	STM32L152QD STM32L152RD STM32L152VD STM32L152ZD

Contents

1	Introduction	8
2	Description	9
2.1	Device overview	10
2.2	Ultralow power device continuum	11
2.2.1	Performance	11
2.2.2	Shared peripherals	11
2.2.3	Common system strategy	11
2.2.4	Features	11
3	Functional overview	12
3.1	Low power modes	13
3.2	ARM® Cortex™-M3 core with MPU	14
3.3	Reset and supply management	15
3.3.1	Power supply schemes	15
3.3.2	Power supply supervisor	15
3.3.3	Voltage regulator	16
3.3.4	Boot modes	16
3.4	Clock management	17
3.5	Low power real-time clock and backup registers	19
3.6	GPIOs (general-purpose inputs/outputs)	19
3.7	Memories	20
3.8	FSMC (flexible static memory controller)	20
3.9	DMA (direct memory access)	20
3.10	LCD (liquid crystal display)	21
3.11	ADC (analog-to-digital converter)	21
3.11.1	Temperature sensor	21
3.11.2	Internal voltage reference (V_{REFINT})	22
3.12	DAC (digital-to-analog converter)	22
3.13	Operational amplifier	23
3.14	Ultralow power comparators and reference voltage	23
3.15	System configuration controller and routing interface	23

3.16	Touch sensing	23
3.17	Timers and watchdogs	24
3.17.1	General-purpose timers (TIM2, TIM3, TIM4, TIM5, TIM9, TIM10 and TIM11)	24
3.17.2	Basic timers (TIM6 and TIM7)	25
3.17.3	SysTick timer	25
3.17.4	Independent watchdog (IWDG)	25
3.17.5	Window watchdog (WWDG)	25
3.18	Communication interfaces	25
3.18.1	I ² C bus	25
3.18.2	Universal synchronous/asynchronous receiver transmitter (USART)	26
3.18.3	Serial peripheral interface (SPI)	26
3.18.4	Inter-integrated sound (I2S)	26
3.18.5	SDIO	26
3.18.6	Universal serial bus (USB)	26
3.19	CRC (cyclic redundancy check) calculation unit	26
3.20	Development support	27
4	Pin descriptions	28
5	Memory mapping	47
6	Electrical characteristics	48
6.1	Parameter conditions	48
6.1.1	Minimum and maximum values	48
6.1.2	Typical values	48
6.1.3	Typical curves	48
6.1.4	Loading capacitor	48
6.1.5	Pin input voltage	48
6.1.6	Power supply scheme	49
6.1.7	Current consumption measurement	49
6.2	Absolute maximum ratings	50
6.3	Operating conditions	51
6.3.1	General operating conditions	51
6.3.2	Embedded reset and power control block characteristics	52
6.3.3	Embedded internal reference voltage	54
6.3.4	Supply current characteristics	55

6.3.5	External clock source characteristics	65
6.3.6	Internal clock source characteristics	72
6.3.7	PLL characteristics	75
6.3.8	Memory characteristics	75
6.3.9	FSMC characteristics	77
6.3.10	EMC characteristics	88
6.3.11	Absolute maximum ratings (electrical sensitivity)	89
6.3.12	I/O current injection characteristics	90
6.3.13	I/O port characteristics	91
6.3.14	NRST pin characteristics	94
6.3.15	TIM timer characteristics	95
6.3.16	Communications interfaces	96
6.3.17	12-bit ADC characteristics	102
6.3.18	DAC electrical specifications	108
6.3.19	Operational amplifier characteristics	110
6.3.20	Temperature sensor characteristics	112
6.3.21	Comparator	112
6.3.22	LCD controller (STM32L152xD only)	114
7	Package characteristics	115
7.1	Package mechanical data	115
7.2	Thermal characteristics	122
7.2.1	Reference document	122
8	Ordering information scheme	123
9	Revision history	124

List of tables

Table 1.	Device summary	1
Table 2.	Ultralow power STM32L15xxD device features and peripheral counts	10
Table 3.	Temperature sensor calibration values.	22
Table 4.	Temperature sensor calibration values.	22
Table 5.	Timer feature comparison.	24
Table 6.	STM32L15xQD BGA132 ballout	28
Table 7.	STM32L15xRD WLCSP64 ballout	31
Table 8.	STM32L15xxD pin definitions	32
Table 9.	Alternate function input/output	38
Table 10.	Voltage characteristics	50
Table 11.	Current characteristics	50
Table 12.	Thermal characteristics.	51
Table 13.	General operating conditions	51
Table 14.	Functionalities depending on the operating power supply range	52
Table 15.	Embedded reset and power control block characteristics.	52
Table 16.	Embedded internal reference voltage.	54
Table 17.	Current consumption in Run mode, code with data processing running from Flash.	55
Table 18.	Current consumption in Run mode, code with data processing running from RAM	56
Table 19.	Current consumption in Sleep mode	57
Table 20.	Current consumption in Low power run mode	58
Table 21.	Current consumption in Low power sleep mode.	59
Table 22.	Typical and maximum current consumptions in Stop mode	60
Table 23.	Typical and maximum current consumptions in Standby mode	61
Table 24.	Typical and maximum timings in Low power modes.	62
Table 25.	Peripheral current consumption	63
Table 26.	High-speed external user clock characteristics.	65
Table 27.	Low-speed external user clock characteristics	67
Table 28.	HSE 1-24 MHz oscillator characteristics.	69
Table 29.	LSE oscillator characteristics ($f_{LSE} = 32.768$ kHz)	70
Table 30.	HSI oscillator characteristics.	72
Table 31.	LSI oscillator characteristics	72
Table 32.	MSI oscillator characteristics	73
Table 33.	PLL characteristics	75
Table 34.	RAM and hardware registers	75
Table 35.	Flash memory and data EEPROM characteristics	76
Table 36.	Flash memory and data EEPROM endurance and retention	76
Table 37.	Asynchronous non-multiplexed SRAM/PSRAM/NOR read timings	78
Table 38.	Asynchronous non-multiplexed SRAM/PSRAM/NOR write timings	79
Table 39.	Asynchronous multiplexed PSRAM/NOR read timings.	80
Table 40.	Asynchronous multiplexed PSRAM/NOR write timings	81
Table 41.	Synchronous multiplexed NOR/PSRAM read timings	83
Table 42.	Synchronous multiplexed PSRAM write timings.	85
Table 43.	Synchronous non-multiplexed NOR/PSRAM read timings	86
Table 44.	Synchronous non-multiplexed PSRAM write timings	87
Table 45.	EMS characteristics	88
Table 46.	EMI characteristics	89
Table 47.	ESD absolute maximum ratings	89
Table 48.	Electrical sensitivities	90

Table 49.	I/O current injection susceptibility	90
Table 50.	I/O static characteristics	91
Table 51.	Output voltage characteristics	92
Table 52.	I/O AC characteristics	93
Table 53.	NRST pin characteristics	94
Table 54.	TIMx characteristics	95
Table 55.	I ² C characteristics	96
Table 56.	SCL frequency (f _{PCLK1} = 32 MHz, V _{DD} = 3.3 V)	97
Table 57.	SPI characteristics	98
Table 58.	USB startup time	100
Table 59.	USB DC electrical characteristics	101
Table 60.	USB: full speed electrical characteristics	101
Table 61.	ADC clock frequency	102
Table 62.	ADC characteristics	102
Table 63.	ADC accuracy	104
Table 64.	R _{AIN} max for f _{ADC} = 16 MHz	106
Table 65.	DAC characteristics	108
Table 66.	Operational amplifier characteristics	110
Table 67.	TS characteristics	112
Table 68.	Comparator 1 characteristics	112
Table 69.	Comparator 2 characteristics	113
Table 70.	LCD controller characteristics	114
Table 71.	LQFP144, 20 x 20 mm, 144-pin low-profile quad flat package mechanical data	116
Table 72.	LQPF100, 14 x 14 mm, 100-pin low-profile quad flat package mechanical data	117
Table 73.	LQFP64, 10 x 10 mm 64-pin low-profile quad flat package mechanical data	118
Table 74.	UFBGA132 package mechanical data	119
Table 75.	WLCSP64, 0.400 mm pitch wafer level chip size package mechanical data	121
Table 76.	Thermal characteristics	122
Table 77.	STM32L15xxD ordering information scheme	123

List of figures

Figure 1.	Ultralow power STM32L15xxD block diagram	12
Figure 2.	Clock tree	18
Figure 3.	STM32L15xZDLQFP144 pinout	29
Figure 4.	STM32L15xVD LQFP100 pinout	30
Figure 5.	STM32L15xRD LQFP64 pinout	30
Figure 6.	Memory map	47
Figure 7.	Pin loading conditions	48
Figure 8.	Pin input voltage	48
Figure 9.	Power supply scheme	49
Figure 10.	Current consumption measurement scheme	49
Figure 11.	Low-speed external clock source AC timing diagram	67
Figure 12.	High-speed external clock source AC timing diagram	68
Figure 13.	HSE oscillator circuit diagram	70
Figure 14.	Typical application with a 32.768 kHz crystal	71
Figure 15.	Asynchronous non-multiplexed SRAM/PSRAM/NOR read waveforms	77
Figure 16.	Asynchronous non-multiplexed SRAM/PSRAM/NOR write waveforms	78
Figure 17.	Asynchronous multiplexed PSRAM/NOR read waveforms	79
Figure 18.	Asynchronous multiplexed PSRAM/NOR write waveforms	80
Figure 19.	Synchronous multiplexed NOR/PSRAM read timings	82
Figure 20.	Synchronous multiplexed PSRAM write timings	84
Figure 21.	Synchronous non-multiplexed NOR/PSRAM read timings	86
Figure 22.	Synchronous non-multiplexed PSRAM write timings	87
Figure 23.	I/O AC characteristics definition	94
Figure 24.	Recommended NRST pin protection	95
Figure 25.	I ² C bus AC waveforms and measurement circuit	97
Figure 26.	SPI timing diagram - slave mode and CPHA = 0	99
Figure 27.	SPI timing diagram - slave mode and CPHA = 1 ⁽¹⁾	99
Figure 28.	SPI timing diagram - master mode ⁽¹⁾	100
Figure 29.	USB timings: definition of data signal rise and fall time	101
Figure 30.	ADC accuracy characteristics	105
Figure 31.	Typical connection diagram using the ADC	105
Figure 32.	Maximum dynamic current consumption on V _{REF+} supply pin during ADC conversion	106
Figure 33.	Power supply and reference decoupling (V _{REF+} not connected to V _{DDA})	107
Figure 34.	Power supply and reference decoupling (V _{REF+} connected to V _{DDA})	107
Figure 35.	12-bit buffered /non-buffered DAC	110
Figure 36.	LQFP144, 20 x 20 mm, 144-pin low-profile quad flat package outline	116
Figure 37.	Recommended footprint	116
Figure 38.	LQFP100, 14 x 14 mm, 100-pin low-profile quad flat package outline	117
Figure 39.	Recommended footprint	117
Figure 40.	LQFP64, 10 x 10 mm, 64-pin low-profile quad flat package outline	118
Figure 41.	Recommended footprint	118
Figure 42.	UFPGA132, 7 x 7 mm, 132-ball ultra thin, fine-pitch ball grid array package outline	119
Figure 43.	WLCSP64, 0.400 mm pitch wafer level chip size package outline	120

1 Introduction

This datasheet provides the ordering information and mechanical device characteristics of the STM32L151xD and STM32L152xD ultralow power ARM Cortex™-based microcontrollers product line.

The ultralow power STM32L15xxD family includes devices in 4 different package types: from 64 pins to 144 pins. Depending on the device chosen, different sets of peripherals are included, the description below gives an overview of the complete range of peripherals proposed in this family.

These features make the ultralow power STM32L15xxD microcontroller family suitable for a wide range of applications:

- Medical and handheld equipment
- Application control and user interface
- PC peripherals, gaming, GPS and sport equipment
- Alarm systems, wired and wireless sensors, Video intercom
- Utility metering

For information on the Cortex™-M3 core please refer to the Cortex™-M3 Technical Reference Manual, available from the www.arm.com website at the following address: <http://infocenter.arm.com/help/index.jsp?topic=/com.arm.doc.ddi0337g>.

Figure 1 shows the general block diagram of the device family.

2 Description

The ultralow power STM32L15xxD incorporates the connectivity power of the universal serial bus (USB) with the high-performance ARM Cortex™-M3 32-bit RISC core operating at a 32 MHz frequency, a memory protection unit (MPU), high-speed embedded memories (Flash memory up to 384 Kbytes and RAM up to 48 Kbytes), a flexible static memory controller (FSMC) interface (for devices with packages of 100 pins and more) and an extensive range of enhanced I/Os and peripherals connected to two APB buses.

The STM32L15xxD devices offer three operational amplifiers, one 12-bit ADC, two DACs, two ultralow power comparators, one general-purpose 32-bit timer, six general-purpose 16-bit timers and two basic timers, which can be used as time bases.

Moreover, the STM32L15xxD devices contain standard and advanced communication interfaces: up to two I²Cs, three SPIs, two I2S, one SDIO, three USARTs, two UARTs and a USB. Up to 34 channels are available for capacitive sensing directly driven through GPIOs and general purpose timers.

They also include a real-time clock and a set of backup registers that remain powered in Standby mode.

Finally, the integrated LCD controller has a built-in LCD voltage generator that allows you to drive up to 8 multiplexed LCDs with contrast independent of the supply voltage.

The ultralow power STM32L15xxD operates from a 1.8 to 3.6 V power supply (down to 1.65 V at power down) with BOR and from a 1.65 to 3.6 V power supply without BOR option. It is available in the -40 to +85 °C temperature range. A comprehensive set of power-saving modes allows the design of low-power applications.



2.1 Device overview

Table 2. Ultralow power STM32L15xxD device features and peripheral counts

Peripheral		STM32L15xRx	STM32L15xVx	STM32L15xQx	STM32L15xZx
Flash - Kbytes		384	384	384	384
Data EEPROM		12	12	12	12
RAM - Kbytes		48	48	48	48
FSMC		No	multiplexed only	Yes	Yes
Timers	32 bit	1	1	1	1
	General-purpose	6	6	6	6
	Basic	2	2	2	2
Communication interfaces	SPI/(I2S)	3/(2)	3/(2)	3/(2)	3/(2)
	I ² C	2	2	2	2
	USART	5	5	5	5
	USB	1	1	1	1
	SDIO	1	1	1	1
GPIOs		51	83	109	115
Operation amplifiers		3	3	3	3
12-bit synchronized ADC		1	1	1	1
Number of channels		21	25	40	40
12-bit DAC		2	2	2	2
Number of channels		2	2	2	2
LCD ⁽¹⁾		1	1	1	1
COM x SEG		4x32 or 8x28	4x44 or 8x40	4x44 or 8x40	4x44 or 8x40
Comparators		2	2	2	2
Capacitive sensing					
No. of channels/No. of groups		23/10	23/10	33/11	34/11
CPU frequency		32 MHz			
Operating voltage		1.8 V to 3.6 V (down to 1.65 V at power-down) with BOR option 1.65 V to 3.6 V without BOR option			
Operating temperatures		Ambient temperature: -40 to +85 °C Junction temperature: -40 to +105 °C			
Packages		LQFP64, WLCSP64	LQFP100	BGA132	LQFP144

1. STM32L152xx devices only.

2.2 Ultralow power device continuum

The ultralow power STM32L158V, STM32L15xxD, STM32L162xD, STM32L15xxC, and STM32L162xC are fully pin-to-pin, software and feature compatible. Besides the full compatibility within the family, the devices are part of STMicroelectronics microcontrollers ultralow power strategy which also includes STM8L101xx and STM8L15xx devices. The STM8L and STM32L families allow a continuum of performance, peripherals, system architecture and features.

They are all based on STMicroelectronics 0.13 µm ultralow leakage process.

Note: The ultralow power STM32L and general-purpose STM32Fxxx families are pin-to-pin compatible. The STM8L15xxx devices are pin-to-pin compatible with the STM8L101xx devices. Please refer to the STM32F and STM8L documentation for more information on these devices.

2.2.1 Performance

All families incorporate highly energy-efficient cores with both Harvard architecture and pipelined execution: advanced STM8 core for STM8L families and ARM Cortex™-M3 core for STM32L family. In addition specific care for the design architecture has been taken to optimize the mA/DMIPS and mA/MHz ratios.

This allows the ultralow power performance to range from 5 up to 33.3 DMIPs.

2.2.2 Shared peripherals

STM8L15xxx and STM32L15xxx share identical peripherals which ensure a very easy migration from one family to another:

- Analog peripherals: ADC, DAC and comparators
- Digital peripherals: RTC and some communication interfaces

2.2.3 Common system strategy

To offer flexibility and optimize performance, the STM8L15xxx and STM32L15xxx families use a common architecture:

- Same power supply range from 1.65 V to 3.6 V
- Architecture optimized to reach ultralow consumption both in low power modes and Run mode
- Fast startup strategy from low power modes
- Flexible system clock
- Ultrasafe reset: same reset strategy including power-on reset, power-down reset, brownout reset and programmable voltage detector

2.2.4 Features

ST ultralow power continuum also lies in feature compatibility:

- More than 10 packages with pin count from 20 to 144 pins and size down to 3 x 3 mm
- Memory density ranging from 4 to 384 Kbytes

3 Functional overview

Figure 1. Ultralow power STM32L15xD block diagram

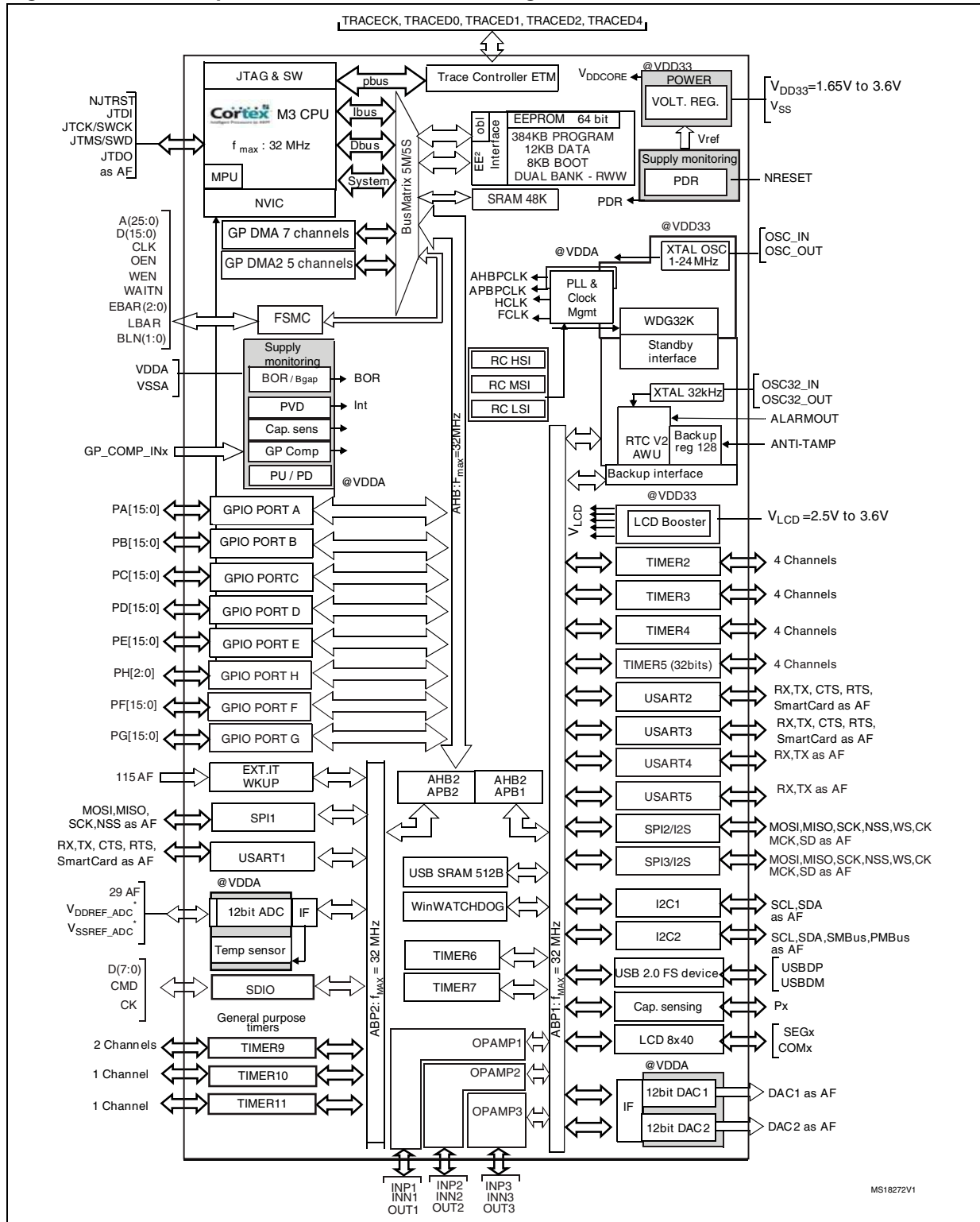

1. Legend:
- AF: alternate function
 - ADC: analog-to-digital converter
 - BOR: brown out reset
 - DMA: direct memory access
 - DAC: digital-to-analog converter
 - I²C: inter-integrated circuit multimaster interface

3.1 Low power modes

The ultralow power STM32L15xxD supports dynamic voltage scaling to optimize its power consumption in run mode. The voltage from the internal low-drop regulator that supplies the logic can be adjusted according to the system's maximum operating frequency and the external voltage supply.

There are three power consumption ranges:

- Range 1 (V_{DD} range limited to 2.0-3.6 V), with the CPU running at up to 32 MHz
- Range 2 (full V_{DD} range), with a maximum CPU frequency of 16 MHz
- Range 3 (full V_{DD} range), with a maximum CPU frequency limited to 4 MHz (generated only with the multispeed internal RC oscillator clock source)

Seven low power modes are provided to achieve the best compromise between low power consumption, short startup time and available wakeup sources:

- **Sleep mode**
In Sleep mode, only the CPU is stopped. All peripherals continue to operate and can wake up the CPU when an interrupt/event occurs. Sleep mode power consumption at 16 MHz is about 1 mA with all peripherals off.
- **Low power run mode**
This mode is achieved with the multispeed internal (MSI) RC oscillator set to the minimum clock (131 kHz), execution from SRAM or Flash memory, and internal regulator in low power mode to minimize the regulator's operating current. In Low power run mode, the clock frequency and the number of enabled peripherals are both limited.
- **Low power sleep mode**
This mode is achieved by entering Sleep mode with the internal voltage regulator in Low power mode to minimize the regulator's operating current. In Low power sleep mode, both the clock frequency and the number of enabled peripherals are limited; a typical example would be to have a timer running at 32 kHz.
When wakeup is triggered by an event or an interrupt, the system reverts to the run mode with the regulator on.
- **Stop mode with RTC**
Stop mode achieves the lowest power consumption while retaining the RAM and register contents and real time clock. All clocks in the V_{CORE} domain are stopped, the PLL, MSI RC, HSI RC and HSE crystal oscillators are disabled. The LSE or LSI is still running. The voltage regulator is in the low power mode.
The device can be woken up from Stop mode by any of the EXTI line, in 8 μ s. The EXTI line source can be one of the 16 external lines. It can be the PVD output, the Comparator 1 event or Comparator 2 event (if internal reference voltage is on), It can be, the RTC alarm(s), the USB wakeup, the RTC tamper events, the RTC timestamp event, the RTC wakeup.

- **Stop mode without RTC**

Stop mode achieves the lowest power consumption while retaining the RAM and register contents. All clocks are stopped, the PLL, MSI RC, HSI and LSI RC, LSE and HSE crystal oscillators are disabled. The voltage regulator is in the low power mode. The device can be woken up from Stop mode by any of the EXTI line, in 8 μ s. The EXTI line source can be one of the 16 external lines. It can be the PVD output, the Comparator 1 event or Comparator 2 event (if internal reference voltage is on). It can also be wakened by the USB wakeup.
- **Standby mode with RTC**

Standby mode is used to achieve the lowest power consumption and real time clock. The internal voltage regulator is switched off so that the entire V_{CORE} domain is powered off. The PLL, MSI RC, HSI RC and HSE crystal oscillators are also switched off. The LSE or LSI is still running. After entering Standby mode, the RAM and register contents are lost except for registers in the Standby circuitry (wakeup logic, IWDG, RTC, LSI, LSE Crystal 32K osc, RCC_CSR).

The device exits Standby mode in 60 μ s when an external reset (NRST pin), an IWDG reset, a rising edge on one of the three WKUP pins, RTC alarm (Alarm A or Alarm B), RTC tamper event, RTC timestamp event or RTC Wakeup event occurs.
- **Standby mode without RTC**

Standby mode is used to achieve the lowest power consumption. The internal voltage regulator is switched off so that the entire V_{CORE} domain is powered off. The PLL, MSI RC, HSI and LSI RC, HSE and LSE crystal oscillators are also switched off. After entering Standby mode, the RAM and register contents are lost except for registers in the Standby circuitry (wakeup logic, IWDG, RTC, LSI, LSE Crystal 32K osc, RCC_CSR).

The device exits Standby mode in 60 μ s when an external reset (NRST pin) or a rising edge on one of the three WKUP pin occurs.

Note: The RTC, the IWDG, and the corresponding clock sources are not stopped automatically by entering Stop or Standby mode.

3.2 ARM[®] Cortex[™]-M3 core with MPU

The ARM Cortex[™]-M3 processor is the industry leading processor for embedded systems. It has been developed to provide a low-cost platform that meets the needs of MCU implementation, with a reduced pin count and low-power consumption, while delivering outstanding computational performance and an advanced system response to interrupts.

The ARM Cortex[™]-M3 32-bit RISC processor features exceptional code-efficiency, delivering the high-performance expected from an ARM core in the memory size usually associated with 8- and 16-bit devices.

The memory protection unit (MPU) improves system reliability by defining the memory attributes (such as read/write access permissions) for different memory regions. It provides up to eight different regions and an optional predefined background region.

Owing to its embedded ARM core, the STM32L15xD is compatible with all ARM tools and software.

Nested vectored interrupt controller (NVIC)

The ultralow power STM32L15xxD embeds a nested vectored interrupt controller able to handle up to 56 maskable interrupt channels (not including the 16 interrupt lines of Cortex™-M3) and 16 priority levels.

- Closely coupled NVIC gives low-latency interrupt processing
- Interrupt entry vector table address passed directly to the core
- Closely coupled NVIC core interface
- Allows early processing of interrupts
- Processing of *late arriving*, higher-priority interrupts
- Support for tail-chaining
- Processor state automatically saved
- Interrupt entry restored on interrupt exit with no instruction overhead

This hardware block provides flexible interrupt management features with minimal interrupt latency.

3.3 Reset and supply management

3.3.1 Power supply schemes

V_{DD} = 1.65 to 3.6 V: external power supply for I/Os and the internal regulator. Provided externally through V_{DD} pins.

V_{SSA} , V_{DDA} = 1.65 to 3.6 V: external analog power supplies for ADC, reset blocks, RCs and PLL (minimum voltage to be applied to V_{DDA} is 1.8 V when the ADC is used). V_{DDA} and V_{SSA} must be connected to V_{DD} and V_{SS} , respectively.

3.3.2 Power supply supervisor

The device has an integrated ZEROPOWER power-on reset (POR)/power-down reset (PDR) that can be coupled with a brownout reset (BOR) circuitry.

The device exists in two versions:

The version with BOR activated at power-on operates between 1.8 V and 3.6 V.

The other version without BOR at power up operates between 1.65 V and 3.6 V.

As the BOR can be activated and deactivated at run time, this distinction is important only for power-up phase.

When BOR is active at power-on, it ensures proper operation starting from 1.8 V whatever the power ramp-up phase before it reaches 1.8 V. When BOR is not active at power-up, the power ramp-up should guarantee that 1.65 V is reached on V_{DD} at least 1 ms after it exits the POR area.

After the V_{DD} threshold is reached (1.65 V or 1.8 V depending on the BOR which is active or not at power-on), the option byte loading process starts, either to confirm or modify default thresholds, or to disable BOR permanently: in this case, the V_{DD} min value at power down is 1.65 V.

Five BOR thresholds are available through option bytes, starting from 1.8 V to 3 V. To reduce the power consumption in Stop mode, it is possible to automatically switch off the internal reference voltage (V_{REFINT}) in Stop mode. The device remains in reset mode when V_{DD} is below a specified threshold, $V_{POR/PDR}$ or V_{BOR} , without the need for any external reset circuit.

Note: The start-up time at power-on is typically 3.3 ms when BOR is active at power-up, the start-up time at power-on can be decreased down to 1 ms typically for devices with BOR inactive at power-up.

The device features an embedded programmable voltage detector (PVD) that monitors the V_{DD}/V_{DDA} power supply and compares it to the V_{PVD} threshold. This PVD offers 7 different levels between 1.85 V and 3.05 V, chosen by software, with a step around 200 mV. An interrupt can be generated when V_{DD}/V_{DDA} drops below the V_{PVD} threshold and/or when V_{DD}/V_{DDA} is higher than the V_{PVD} threshold. The interrupt service routine can then generate a warning message and/or put the MCU into a safe state. The PVD is enabled by software.

3.3.3 Voltage regulator

The regulator has three operation modes: main (MR), low power (LPR) and power down.

MR is used in Run mode (nominal regulation)

LPR is used in the Low power run, Low power sleep and Stop modes

Power down is used in Standby mode. The regulator output is high impedance, the kernel circuitry is powered down, inducing zero consumption but the contents of the registers and RAM are lost except for the standby circuitry (wake-up logic, IWDG, RTC, LSI, LSE crystal 32K osc, RCC_CSR).

3.3.4 Boot modes

At startup, boot pins are used to select one of three boot options:

Boot from Flash memory

Boot from System memory

Boot from embedded RAM

The boot from Flash usually boots at the beginning of the Flash (bank 1). An additional boot mechanism is available through user option byte, to allow booting from bank 2 when bank 2 contains valid code. This dual boot capability can be used to easily implement a secure field software update mechanism.

The boot loader is located in System memory. It is used to reprogram the Flash memory by using USART1, USART2 or USB.

3.4 Clock management

The clock controller distributes the clocks coming from different oscillators to the core and the peripherals. It also manages clock gating for low power modes and ensures clock robustness. It features:

Clock prescaler: to get the best trade-off between speed and current consumption, the clock frequency to the CPU and peripherals can be adjusted by a programmable prescaler.

Safe clock switching: clock sources can be changed safely on the fly in run mode through a configuration register.

Clock management: to reduce power consumption, the clock controller can stop the clock to the core, individual peripherals or memory.

System clock source: three different clock sources can be used to drive the master clock SYSCLK:

- 1-24 MHz high-speed external crystal (HSE), that can supply a PLL
- 16 MHz high-speed internal RC oscillator (HSI), trimmable by software, that can supply a PLL
- Multispeed internal RC oscillator (MSI), trimmable by software, able to generate 7 frequencies (65 kHz, 131 kHz, 262 kHz, 524 kHz, 1.05 MHz, 2.1 MHz, 4.2 MHz). When a 32.768 kHz clock source is available in the system (LSE), the MSI frequency can be trimmed by software down to a $\pm 0.5\%$ accuracy.

Auxiliary clock source: two ultralow power clock sources that can be used to drive the LCD controller and the real-time clock:

- 32.768 kHz low-speed external crystal (LSE)
- 37 kHz low-speed internal RC (LSI), also used to drive the independent watchdog. The LSI clock can be measured using the high-speed internal RC oscillator for greater precision.

RTC and LCD clock sources: the LSI, LSE or HSE sources can be chosen to clock the RTC and the LCD, whatever the system clock.

USB clock source: the embedded PLL has a dedicated 48 MHz clock output to supply the USB interface.

Startup clock: after reset, the microcontroller restarts by default with an internal 2 MHz clock (MSI). The prescaler ratio and clock source can be changed by the application program as soon as the code execution starts.

Clock security system (CSS): this feature can be enabled by software. If a HSE clock failure occurs, the master clock is automatically switched to HSI and a software interrupt is generated if enabled.

Clock-out capability (MCO: microcontroller clock output): it outputs one of the internal clocks for external use by the application.

Several prescalers allow the configuration of the AHB frequency, each APB (APB1 and APB2) domains. The maximum frequency of the AHB and the APB domains is 32 MHz. See [Figure 2](#) for details on the clock tree.

Figure 2. Clock tree

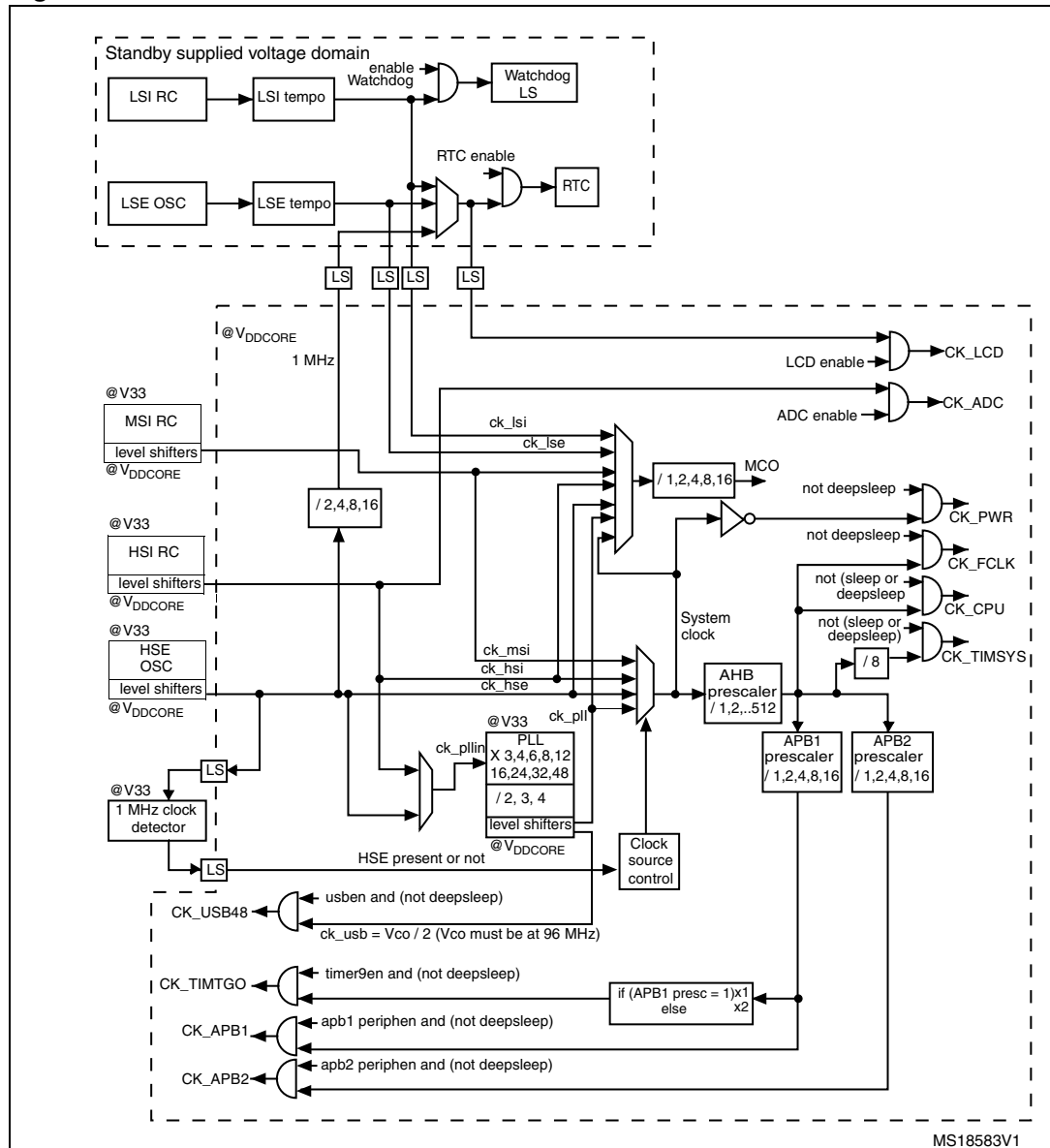

1. For the USB function to be available, both HSE and PLL must be enabled, with the CPU running at either 24 MHz or 32 MHz.

3.5 Low power real-time clock and backup registers

The real-time clock (RTC) is an independent BCD timer/counter. Dedicated registers contain the sub-second, second, minute, hour (12/24 hour), week day, date, month, year, in BCD (binary-coded decimal) format. Correction for 28, 29 (leap year), 30, and 31 day of the month are made automatically. The RTC provides two programmable alarms and programmable periodic interrupts with wakeup from Stop and Standby modes.

The programmable wakeup time ranges from 120 μ s to 36 hours.

The RTC can be calibrated with an external 512 Hz output, and a digital compensation circuit helps reduce drift due to crystal deviation.

The RTC can also be automatically corrected with a 50/60Hz stable powerline.

The RTC calendar can be updated on the fly down to sub second precision, which enables network system synchronisation.

A time stamp can record an external event occurrence, and generates an interrupt.

There are thirty-two 32-bit backup registers provided to store 128 bytes of user application data. They are cleared in case of tamper detection.

Three pins can be used to detect tamper events. A change on one of these pins can reset backup register and generate an interrupt. To prevent false tamper event, like ESD event, these three tamper inputs can be digitally filtered.

3.6 GPIOs (general-purpose inputs/outputs)

Each of the GPIO pins can be configured by software as output (push-pull or open-drain), as input (with or without pull-up or pull-down) or as peripheral alternate function. Most of the GPIO pins are shared with digital or analog alternate functions, and can be individually remapped using dedicated AFIO registers. All GPIOs are high current capable. The alternate function configuration of I/Os can be locked if needed following a specific sequence in order to avoid spurious writing to the I/O registers. The I/O controller is connected to the AHB with a toggling speed of up to 16 MHz.

External interrupt/event controller (EXTI)

The external interrupt/event controller consists of 23 edge detector lines used to generate interrupt/event requests. Each line can be individually configured to select the trigger event (rising edge, falling edge, both) and can be masked independently. A pending register maintains the status of the interrupt requests. The EXTI can detect an external line with a pulse width shorter than the Internal APB2 clock period. Up to 115 GPIOs can be connected to the 16 external interrupt lines. The 7 other lines are connected to RTC, PVD, USB or Comparator events.

3.7 Memories

The STM32L15xxD devices have the following features:

- 48 Kbytes of embedded RAM accessed (read/write) at CPU clock speed with 0 wait states. With the enhanced bus matrix, operating the RAM does not lead to any performance penalty during accesses to the system bus (AHB and APB buses).
- The non-volatile memory is divided into three arrays:
 - 384 Kbytes of embedded Flash program memory
 - 12 Kbytes of data EEPROM
 - Options bytes

Flash program and data EEPROM are divided into two banks, this enables writing in one bank while running code or reading data in the other bank.

The options bytes are used to write-protect the memory (with 4 KB granularity) and/or readout-protect the whole memory with the following options:

- Level 0: no readout protection
- Level 1: memory readout protection, the Flash memory cannot be read from or written to if either debug features are connected or boot in RAM is selected
- Level 2: chip readout protection, debug features (Cortex-M3 JTAG and serial wire) and boot in RAM selection disabled (JTAG fuse)

The whole non-volatile memory embeds the error correction code (ECC) feature.

3.8 FSMC (flexible static memory controller)

The FSMC supports the following modes: SRAM, PSRAM, NOR Flash.

Functionality overview:

- Up to 26 bit address bus
- Up to 16-bit data bus
- Write FIFO
- Burst mode
- Code execution from external memory
- Four chip select signals
- Up to 32 MHz external access (TBC)

3.9 DMA (direct memory access)

The flexible 12-channel, general-purpose DMA is able to manage memory-to-memory, peripheral-to-memory and memory-to-peripheral transfers. The DMA controller supports circular buffer management, avoiding the generation of interrupts when the controller reaches the end of the buffer.

Each channel is connected to dedicated hardware DMA requests, with software trigger support for each channel. Configuration is done by software and transfer sizes between source and destination are independent.

The DMA can be used with the main peripherals: SPI, I²C, USART, SDIO, general-purpose timers, DAC, and ADC.

3.10 LCD (liquid crystal display)

The LCD drives up to 8 common terminals and 44 segment terminals to drive up to 320 pixels.

- Internal step-up converter to guarantee functionality and contrast control irrespective of V_{DD} . This converter can be deactivated, in which case the V_{LCD} pin is used to provide the voltage to the LCD
- Supports static, 1/2, 1/3, 1/4 and 1/8 duty
- Supports static, 1/2, 1/3 and 1/4 bias
- Phase inversion to reduce power consumption and EMI
- Up to 8 pixels can be programmed to blink
- Unneeded segments and common pins can be used as general I/O pins
- LCD RAM can be updated at any time owing to a double-buffer
- The LCD controller can operate in Stop mode

3.11 ADC (analog-to-digital converter)

A 12-bit analog-to-digital converters is embedded into STM32L15xxD devices with up to 40 external channels, performing conversions in single-shot or scan mode. In scan mode, automatic conversion is performed on a selected group of analog inputs with up to 29 external channel in a group.

The ADC can be served by the DMA controller.

An analog watchdog feature allows very precise monitoring of the converted voltage of one, some or all scanned channels. An interrupt is generated when the converted voltage is outside the programmed thresholds.

The events generated by the general-purpose timers (TIMx) can be internally connected to the ADC start triggers, to allow the application to synchronize A/D conversions and timers. An injection mode allows high priority conversions to be done by interrupting a scan mode which runs in as a background task.

The ADC includes a specific low power mode. The converter is able to operate at maximum speed even if the CPU is operating at a very low frequency and has an auto-shutdown function. The ADC's runtime and analog front-end current consumption are thus minimized whatever the MCU operating mode.

3.11.1 Temperature sensor

The temperature sensor (TS) generates a voltage V_{SENSE} that varies linearly with temperature.

The temperature sensor is internally connected to the ADC_IN16 input channel which is used to convert the sensor output voltage into a digital value.

The sensor provides good linearity but it has to be calibrated to obtain good overall accuracy of the temperature measurement. As the offset of the temperature sensor varies from chip to chip due to process variation, the uncalibrated internal temperature sensor is suitable for applications that detect temperature changes only.

To improve the accuracy of the temperature sensor measurement, each device is individually factory-calibrated by ST. The temperature sensor factory calibration data are stored by ST in the system memory area, accessible in read-only mode.

Table 3. Temperature sensor calibration values

Calibration value name	Description	Memory address
TS_CAL1	TS ADC raw data acquired at temperature of 30 °C, $V_{DDA} = 3\text{ V}$	0x1FF8 00FA - 0x1FF8 00FB
TS_CAL2	TS ADC raw data acquired at temperature of 110 °C $V_{DDA} = 3\text{ V}$	0x1FF8 00FE - 0x1FF8 00FF

3.11.2 Internal voltage reference (V_{REFINT})

The internal voltage reference (V_{REFINT}) provides a stable (bandgap) voltage output for the ADC and Comparators. V_{REFINT} is internally connected to the ADC_IN17 input channel. The precise voltage of V_{REFINT} is individually measured for each part by ST during production test and stored in the system memory area. It is accessible in read-only mode.

Table 4. Temperature sensor calibration values

Calibration value name	Description	Memory address
VREFINT_CAL	Raw data acquired at temperature of 30 °C $V_{DDA} = 3\text{ V}$	0x1FF8 00F8 - 0x1FF8 00F9

3.12 DAC (digital-to-analog converter)

The two 12-bit buffered DAC channels can be used to convert two digital signals into two analog voltage signal outputs. The chosen design structure is composed of integrated resistor strings and an amplifier in non-inverting configuration.

This dual digital Interface supports the following features:

- Two DAC converters: one for each output channel
- Up to 10-bit output
- Left or right data alignment in 12-bit mode
- Synchronized update capability
- Noise-wave generation
- Triangular-wave generation
- Dual DAC channels, independent or simultaneous conversions
- DMA capability for each channel (including the underrun interrupt)
- External triggers for conversion
- Input reference voltage V_{REF+}

Eight DAC trigger inputs are used in the STM32L15xxD. The DAC channels are triggered through the timer update outputs that are also connected to different DMA channels.

3.13 Operational amplifier

The STM32L15xxD embeds three operational amplifiers with external or internal follower routing capability (or even amplifier and filter capability with external components). When one operational amplifier is selected, one external ADC channel is used to enable output measurement.

The operational amplifiers feature:

- Low input bias current
- Low offset voltage
- Low power mode
- Rail-to-rail input

3.14 Ultralow power comparators and reference voltage

The STM32L15xxD embeds two comparators sharing the same current bias and reference voltage. The reference voltage can be internal or external (coming from an I/O).

- One comparator with fixed threshold
- One comparator with rail-to-rail inputs, fast or slow mode. The threshold can be one of the following:
 - DAC output
 - External I/O
 - Internal reference voltage (V_{REFINT}) or a submultiple (1/4, 1/2, 3/4)

Both comparators can wake up from Stop mode, and be combined into a window comparator.

The internal reference voltage is available externally via a low power / low current output buffer (driving current capability of 1 μ A typical).

3.15 System configuration controller and routing interface

The system configuration controller provides the capability to remap some alternate functions on different I/O ports.

The highly flexible routing interface allows the application firmware to control the routing of different I/Os to the TIM2, TIM3 and TIM4 timer input captures. It also controls the routing of internal analog signals to ADC1, COMP1 and COMP2 and the internal reference voltage V_{REFINT} .

3.16 Touch sensing

The STM32L15xxD devices provide a simple solution for adding capacitive sensing functionality to any application. Capacitive sensing technology is able to detect finger presence near an electrode which is protected from direct touch by a dielectric (glass, plastic...). The capacitive variation introduced by the finger (or any conductive object) is measured using a proven implementation based on a surface charge transfer acquisition principle. It consists of charging the electrode capacitance and then transferring a part of the accumulated charges into a sampling capacitor until the voltage across this capacitor has reached a specific threshold. In the STM32L15xxD, this acquisition is managed directly by

the GPIOs, timers and analog I/O groups (see [Section 3.15: System configuration controller and routing interface](#)).

Reliable touch sensing solution can be quickly and easily implemented using the free STM32L1xx STMTouch firmware library.

3.17 Timers and watchdogs

The ultralow power STM32L15xxD devices include seven general-purpose timers, two basic timers, and two watchdog timers.

[Table 5](#) compares the features of the general-purpose and basic timers.

Table 5. Timer feature comparison

Timer	Counter resolution	Counter type	Prescaler factor	DMA request generation	Capture/compare channels	Complementary outputs
TIM2, TIM3, TIM4	16-bit	Up, down, up/down	Any integer between 1 and 65536	Yes	4	No
TIM5	32-bit	Up, down, up/down	Any integer between 1 and 65536	Yes	4	No
TIM9	16-bit	Up, down, up/down	Any integer between 1 and 65536	No	2	No
TIM10, TIM11	16-bit	Up	Any integer between 1 and 65536	No	1	No
TIM6, TIM7	16-bit	Up	Any integer between 1 and 65536	Yes	0	No

3.17.1 General-purpose timers (TIM2, TIM3, TIM4, TIM5, TIM9, TIM10 and TIM11)

There are seven synchronizable general-purpose timers embedded in the STM32L15xxD devices (see [Table 5](#) for differences).

TIM2, TIM3, TIM4, TIM5

TIM2, TIM3, TIM4 are based on 16-bit auto-reload up/down counter. TIM5 is based on a 32-bit auto-reload up/down counter. They include a 16-bit prescaler. They feature four independent channels each for input capture/output compare, PWM or one-pulse mode output. This gives up to 16 input captures/output compares/PWMs on the largest packages.

TIM2, TIM3, TIM4, TIM5 general-purpose timers can work together or with the TIM10, TIM11 and TIM9 general-purpose timers via the Timer Link feature for synchronization or event chaining. Their counter can be frozen in debug mode. Any of the general-purpose timers can be used to generate PWM outputs.

TIM2, TIM3, TIM4, TIM5 all have independent DMA request generation.

These timers are capable of handling quadrature (incremental) encoder signals and the digital outputs from 1 to 3 hall-effect sensors.

TIM10, TIM11 and TIM9

TIM10 and TIM11 are based on a 16-bit auto-reload upcounter. TIM9 is based on a 16-bit auto-reload up/down counter. They include a 16-bit prescaler. TIM10 and TIM11 feature one independent channel, whereas TIM9 has two independent channels for input capture/output compare, PWM or one-pulse mode output. They can be synchronized with the TIM2, TIM3, TIM4, TIM5 full-featured general-purpose timers.

They can also be used as simple time bases and be clocked by the LSE clock source (32.768 kHz) to provide time bases independent from the main CPU clock.

3.17.2 Basic timers (TIM6 and TIM7)

These timers are mainly used for DAC trigger generation. They can also be used as generic 16-bit time bases.

3.17.3 SysTick timer

This timer is dedicated to the OS, but could also be used as a standard downcounter. It is based on a 24-bit downcounter with autoreload capability and a programmable clock source. It features a maskable system interrupt generation when the counter reaches 0.

3.17.4 Independent watchdog (IWDG)

The independent watchdog is based on a 12-bit downcounter and 8-bit prescaler. It is clocked from an independent 37 kHz internal RC and, as it operates independently of the main clock, it can operate in Stop and Standby modes. It can be used either as a watchdog to reset the device when a problem occurs, or as a free-running timer for application timeout management. It is hardware- or software-configurable through the option bytes. The counter can be frozen in debug mode.

3.17.5 Window watchdog (WWDG)

The window watchdog is based on a 7-bit downcounter that can be set as free-running. It can be used as a watchdog to reset the device when a problem occurs. It is clocked from the main clock. It has an early warning interrupt capability and the counter can be frozen in debug mode.

3.18 Communication interfaces

3.18.1 I²C bus

Up to two I²C bus interfaces can operate in multimaster and slave modes. They can support standard and fast modes.

They support dual slave addressing (7-bit only) and both 7- and 10-bit addressing in master mode. A hardware CRC generation/verification is embedded.

They can be served by DMA and they support SM Bus 2.0/PM Bus.

3.18.2 Universal synchronous/asynchronous receiver transmitter (USART)

The three USART and two UART interfaces are able to communicate at speeds of up to 4 Mbit/s. They support IrDA SIR ENDEC, are ISO 7816 compliant and have LIN Master/Slave capability. The three USARTs provide hardware management of the CTS and RTS signals.

All USART/UART interfaces can be served by the DMA controller.

3.18.3 Serial peripheral interface (SPI)

Up to three SPIs are able to communicate at up to 16 Mbits/s in slave and master modes in full-duplex and simplex communication modes. The 3-bit prescaler gives 8 master mode frequencies and the frame is configurable to 8 bits or 16 bits. The hardware CRC generation/verification supports basic SD Card/MMC modes.

The SPIs can be served by the DMA controller.

3.18.4 Inter-integrated sound (I²S)

Two standard I2S interfaces (multiplexed with SPI2 and SPI3) are available. They can operate in master or slave mode, and can be configured to operate with a 16-/32-bit resolution as input or output channels. Audio sampling frequencies from 8 kHz up to 96 kHz are supported. When either or both of the I2S interfaces is/are configured in master mode, the master clock can be output to the external DAC/CODEC at 256 times the sampling frequency.

3.18.5 SDIO

An SD/SDIO/MMC host interface is available, that supports MultiMediaCard System Specification Version 4.2 in three different databus modes: 1-bit (default), 4-bit and 8-bit.

The interface allows data transfer at up to 48 MHz in 8-bit mode, and is compliant with the SD Memory Card Specification Version 2.0.

The SDIO Card Specification Version 2.0 is also supported with two different databus modes: 1-bit (default) and 4-bit.

The current version supports only one SD/SDIO/MMC4.2 card at any one time and a stack of MMC4.1 or previous.

In addition to SD/SDIO/MMC, this interface is fully compliant with the CE-ATA digital protocol Rev1.1.

3.18.6 Universal serial bus (USB)

The STM32L15xxD embeds a USB device peripheral compatible with the USB full-speed 12 Mbit/s. The USB interface implements a full-speed (12 Mbit/s) function interface. It has software-configurable endpoint setting and supports suspend/resume. The dedicated 48 MHz clock is generated from the internal main PLL (the clock source must use a HSE crystal oscillator).

3.19 CRC (cyclic redundancy check) calculation unit

The CRC (cyclic redundancy check) calculation unit is used to get a CRC code from a 32-bit data word and a fixed generator polynomial.

Among other applications, CRC-based techniques are used to verify data transmission or storage integrity. In the scope of the EN/IEC 60335-1 standard, they offer a means of verifying the Flash memory integrity. The CRC calculation unit helps compute a signature of the software during runtime, to be compared with a reference signature generated at link-time and stored at a given memory location.

3.20 Development support

Serial wire JTAG debug port (SWJ-DP)

The ARM SWJ-DP interface is embedded, and is a combined JTAG and serial wire debug port that enables either a serial wire debug or a JTAG probe to be connected to the target. The JTAG TMS and TCK pins are shared with SWDIO and SWCLK, respectively, and a specific sequence on the TMS pin is used to switch between JTAG-DP and SW-DP.

The JTAG port can be permanently disabled with a JTAG fuse.

Embedded Trace Macrocell™

The ARM® Embedded Trace Macrocell provides a greater visibility of the instruction and data flow inside the CPU core by streaming compressed data at a very high rate from the STM32L15xxD through a small number of ETM pins to an external hardware trace port analyzer (TPA) device. The TPA is connected to a host computer using USB, Ethernet, or any other high-speed channel. Real-time instruction and data flow activity can be recorded and then formatted for display on the host computer running debugger software. TPA hardware is commercially available from common development tool vendors. It operates with third party debugger software tools.

4 Pin descriptions

Table 6. STM32L15xQD BGA132 ballout⁽¹⁾

	1	2	3	4	5	6	7	8	9	10	11	12
A	PE3	PE1	PB8	BOOT0	PD7	PD5	PB4	PB3	PA15	PA14	PA13	PA12
B	PE4	PE2	PB9	PB7	PB6	PD6	PD4	PD3	PD1	PC12	PC10	PA11
C	PC13- WKUP2	PE5	PE0	V _{DD_3}	PB5	PG14	PG13	PD2	PD0	PC11	PH2	PA10
D	PC14- OSC32 _IN	PE6- WKUP3	V _{SS_3}	PF2	PF1	PF0	PG12	PG10	PG9	PA9	PA8	PC9
E	PC15- OSC32 _OUT	VLCD	V _{SS_6}	PF3					PG5	PC8	PC7	PC6
F	PH0 OSC_IN	V _{SS_5}	PF4	PF5		V _{SS_9}	V _{SS_10}		PG3	PG4	V _{SS_2}	V _{SS_1}
G	PH1 OSC _OUT	V _{DD_5}	PF6	PF7		V _{DD_9}	V _{DD_10}		PG1	PG2	V _{DD_2}	V _{DD_1}
H	PC0	NRST	V _{DD_6}	PF8					PG0	PD15	PD14	PD13
J	V _{SSA}	PC1	PC2	PA4	PA7	PF9	PF12	PF14	PF15	PD12	PD11	PD10
K	OPAMP 3_ VINM	PC3	PA2	PA5	PC4	PF11	PF13	PD9	PD8	PB15	PB14	PB13
L	V _{REF+}	PA0- WKUP1	PA3	PA6	PC5	PB2	PE8	PE10	PE12	PB10	PB11	PB12
M	V _{DDA}	PA1	OPAM P1_ VINM	OPAMP 2_ VINM	PB0	PB1	PE7	PE9	PE11	PE13	PE14	PE15

1. This figure shows the package top view.

Figure 3. STM32L15xZDLQFP144 pinout

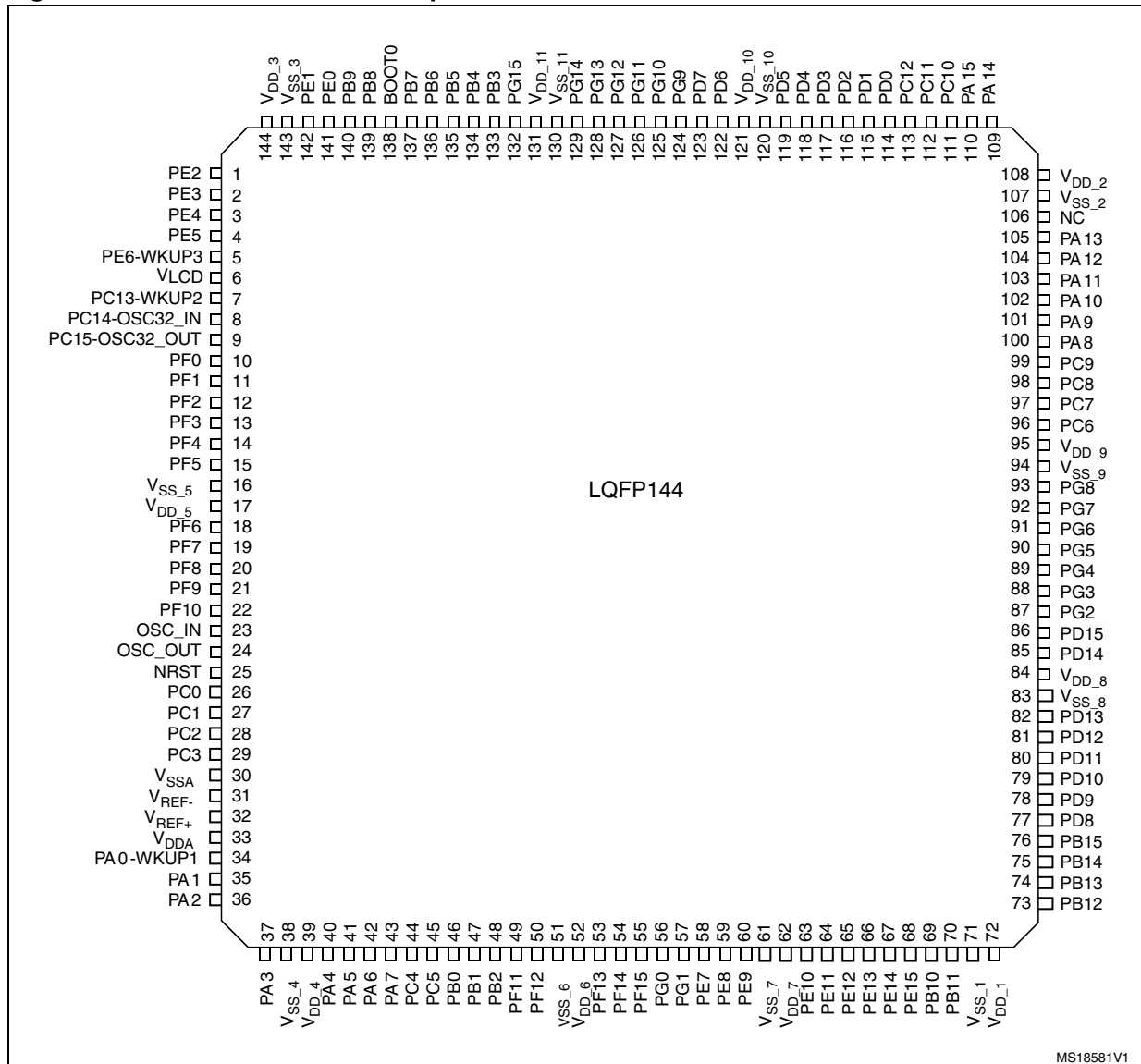

MS18581V1

Figure 4. STM32L15xVD LQFP100 pinout

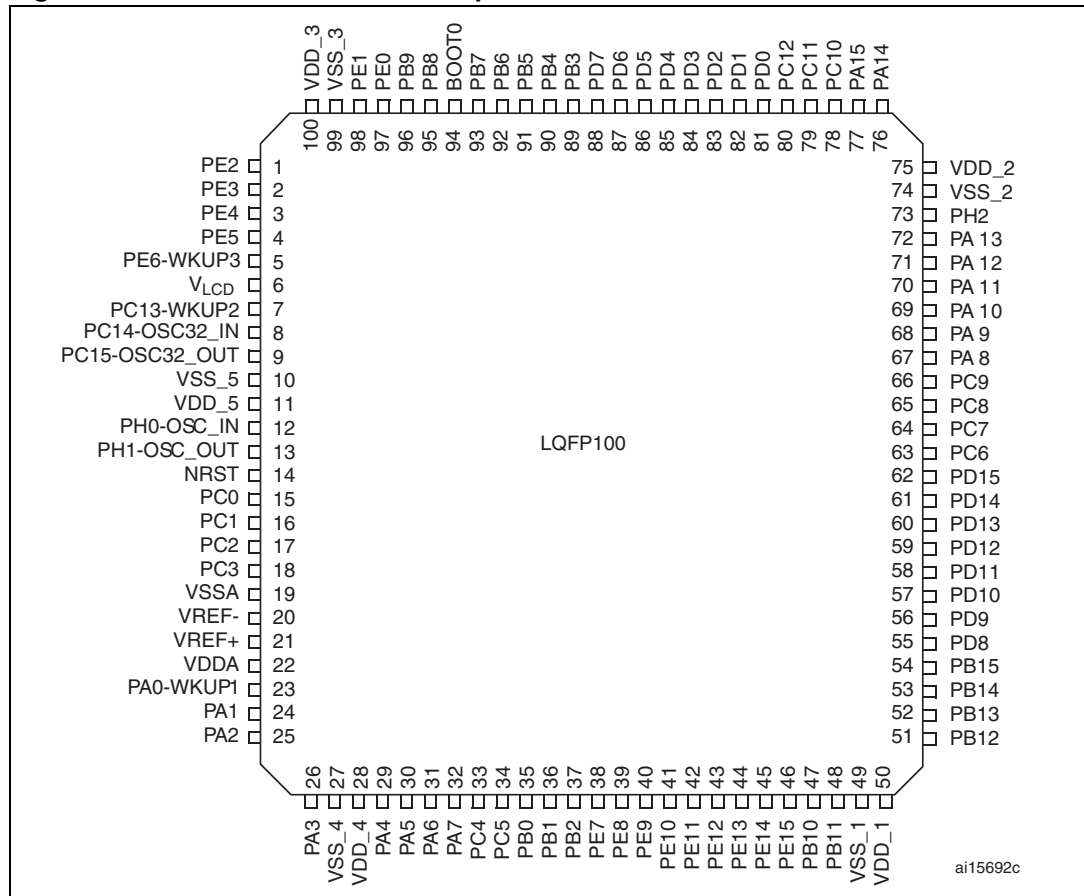

Figure 5. STM32L15xRD LQFP64 pinout

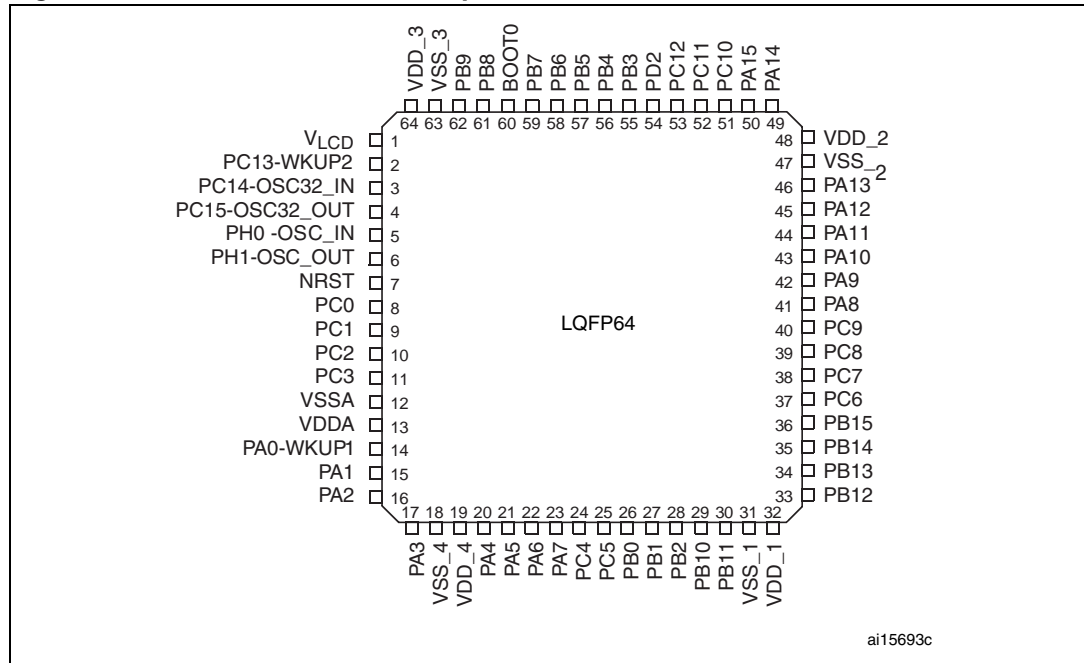

Table 7. STM32L15xRD WLCSP64 ballout⁽¹⁾

	1	2	3	4	5	6	7	8
A	V _{DD_2}	PC10	PD2	PB3	PB5	BOOT0	V _{SS_3}	V _{DD_3}
B	V _{SS_2}	PA14	PC11	PB4	PB6	PB9	PC15- OSC32_OUT	PC14- OSC32_IN
C	PA11	PA12	PA15	PC12	PB7	V _{LCD}	NRST	PC13- WKUP2
D	PC9	PA9	PA10	PA13	PB8	PC2	PH1- OSC_OUT	PH0- OSC_IN
E	PC6	PC7	PC8	PA8	PA5	PA1	V _{SSA}	PC0
F	PB15	PB14	PB11	PB1	V _{SS_4}	PA0- WKUP1	PC3	PC1
G	PB13	PB12	PB10	PA7	PA6	V _{DD_4}	PA3	V _{DDA}
H	V _{DD_1}	V _{SS_1}	PB2	PB0	PC5	PC4	PA4	PA2

1. This figure shows the package top view.

Table 8. STM32L15xxD pin definitions

Pins					Pin name	Type ⁽¹⁾	I/O Level ⁽²⁾	Main function ⁽³⁾ (after reset)	Alternate functions
LQFP144	UFBGA132	LQFP100	LQFP64	WLCSP64					
1	B2	1	-	-	PE2	I/O	FT	PE2	TIM3_ETR/LCD_SEG38/ FSMC_A23/TRACECK
2	A1	2	-	-	PE3	I/O	FT	PE3	TIM3_CH1/LCD_SEG39/ FSMC_A19/TRACED0
3	B1	3	-	-	PE4	I/O	FT	PE4	TIM3_CH2/FSMC_A20/TRACED1
4	C2	4	-	-	PE5	I/O	FT	PE5	TIM9_CH1/FSMC_A21/TRACED2
5	D2	5	-	-	PE6- WKUP3	I/O	FT	PE6	WKUP3/TAMPER3/TIM9_CH2/TRACED3
6	E2	6	1	C6	V _{LCD} ⁽⁴⁾	S		V _{LCD}	
7	C1	7	2	C8	PC13-WKUP2	I/O	FT	PC13	WKUP2/TAMPER1/RTC_AF1
8	D1	8	3	B8	PC14- OSC32_IN ⁽⁵⁾	I/O		PC14	OSC32_IN
9	E1	9	4	B7	PC15- OSC32_OUT	I/O		PC15	OSC32_OUT
10	D6	-	-	-	PF0	I/O	FT	PF0	FSMC_A0
11	D5	-	-	-	PF1	I/O	FT	PF1	FSMC_A1
12	D4	-	-	-	PF2	I/O	FT	PF2	FSMC_A2
13	E4	-	-	-	PF3	I/O	FT	PF3	FSMC_A3
14	F3	-	-	-	PF4	I/O	FT	PF4	FSMC_A4
15	F4	-	-	-	PF5	I/O	FT	PF5	FSMC_A5
16	F2	10	-	-	V _{SS_5}	S		V _{SS_5}	
17	G2	11	-	-	V _{DD_5}	S		V _{DD_5}	
18	G3	-	-	-	PF6	I/O	FT	PF6	TIM5_CH1/TIM5_ETR/ADC_IN27
19	G4	-	-	-	PF7	I/O	FT	PF7	TIM5_CH2/ADC_IN28/COMP1_INP
20	H4	-	-	-	PF8	I/O	FT	PF8	TIM5_CH3/ADC_IN29/COMP1_INP
21	J6	-	-	-	PF9	I/O	FT	PF9	TIM5_CH4/ADC_IN30/COMP1_INP
22	-	-	-	-	PF10	I/O	FT	PF10	ADC_IN30/COMP1_INP
23	F1	12	5	D8	PH0-OSC_IN ⁽⁶⁾	I		PH0	OSC_IN
24	G1	13	6	D7	PH1- OSC_OUT ⁽⁶⁾	O		PH1	OSC_VOUT
25	H2	14	7	C7	NRST	I/O		NRST	
26	H1	15	8	E8	PC0	I/O	FT	PC0	LCD_SEG18/ADC_IN10/COMP1_INP
27	J2	16	9	F8	PC1	I/O	FT	PC1	LCD_SEG19/ADC_IN11/COMP1_INP/OPAMP3_VIN P
28		17	10	D6	PC2	I/O	FT	PC2	LCD_SEG20/ADC_IN12/COMP1_INP/OPAMP3_VIN M
	J3			-	PC2	I/O	FT	PC2	LCD_SEG20/ADC_IN12/COMP1_INP
	K1			-	OPAMP3_VINM	I		OPAMP3_VI NM	

Table 8. STM32L15xxD pin definitions (continued)

Pins					Pin name	Type ⁽¹⁾	I/O Level ⁽²⁾	Main function ⁽³⁾ (after reset)	Alternate functions
LQFP144	UFBGA132	LQFP100	LQFP64	WLCSP64					
29	K2	18	11	F7	PC3	I/O		PC3	LCD_SEG21/ADC_IN13/COMP1_INP/OPAMP3_VOUT
30	J1	19	12	E7	V _{SSA}	S		V _{SSA}	
31	-	20	-	-	V _{REF-}	S		V _{REF-}	
32	L1	21	-	-	V _{REF+}	S		V _{REF+}	
33	M1	22	13	G8	V _{DDA}	S		V _{DDA}	
34	L2	23	14	F6	PA0-WKUP1	I/O	FT	PA0	WKUP1/TAMPER2/TIM2_CH1_ETR/TIM5_CH1/USART2_CTS/ADC_IN0/COMP1_INP
35	M2	24	15	E6	PA1	I/O	FT	PA1	TIM2_CH2/TIM5_CH2/ USART2_RTS/LCD_SEG0/ADC_IN1/COMP1_INP/OPAMP1_VINP
36		25	16	H8	PA2	I/O	FT	PA2	TIM2_CH3/TIM5_CH3/TIM9_CH1/USART2_TX/LCD_SEG1/ADC_IN2/ COMP1_INP/OPAMP1_VINM
	K3		-	-	PA2	I/O	FT	PA2	TIM2_CH3/TIM5_CH3/TIM9_CH1/USART2_TX/LCD_SEG1/ADC_IN2/ COMP1_INP
	M3		-	-	OPAMP1_VINM	I		OPAMP1_VINM	
37	L3	26	17	G7	PA3	I/O		PA3	TIM2_CH4/TIM5_CH4/TIM9_CH2/USART2_RX/LCD_SEG2/ ADC_IN3/COMP1_INP/OPAMP1_OUT
38	-	27	18	F5	V _{SS_4}	S		V _{SS_4}	
39	-	28	19	G6	V _{DD_4}	S		V _{DD_4}	
40	J4	29	20	H7	PA4	I/O		PA4	SPI1_NSS/SPI3_NSS/ I2S3_WS/USART2_CK/ADC_IN4/DAC_OUT1/COMP1_INP
41	K4	30	21	E5	PA5	I/O		PA5	TIM2_CH1_ETR/SPI1_SCK/ADC_IN5/DAC_OUT2/COMP1_INP
42	L4	31	22	G5	PA6	I/O	FT	PA6	TIM3_CH1/TIM10_CH1/SPI1_MISO/LCD_SEG3/ADC_IN6/COMP1_INP/OPAMP2_VINP
43		32	23	G4	PA7	I/O	FT	PA7	TIM3_CH2/TIM11_CH1/ SPI1_MOSI/LCD_SEG4/ADC_IN7/COMP1_INP/OPAMP2_VINM
	J5		-	-	PA7	I/O	FT	PA7	TIM3_CH2/TIM11_CH1/ SPI1_MOSI/LCD_SEG4/ADC_IN7/COMP1_INP
	M4		-	-	OPAMP2_VINM	I		OPAMP2_VINM	
44	K5	33	24	H6	PC4	I/O	FT	PC4	LCD_SEG22/ADC_IN14/COMP1_INP
45	L5	34	25	H5	PC5	I/O	FT	PC5	LCD_SEG23/ADC_IN15/COMP1_INP
46	M5	35	26	H4	PB0	I/O		PB0	TIM3_CH3/LCD_SEG5/ADC_IN8/COMP1_INP/VREF_OUT/ OPAMP2_VOUT
47	M6	36	27	F4	PB1	I/O	FT	PB1	TIM3_CH4/LCD_SEG6/ADC_IN9/COMP1_INP/VREF_OUT
48	L6	37	28	H3	PB2	I/O	FT	PB2/BOOT1	ADC_IN0b/COMP1_INP
49	K6	-	-	-	PF11	I/O	FT	PF11	ADC_IN1b/COMP1_INP

Table 8. STM32L15xxD pin definitions (continued)

Pins					Pin name	Type ⁽¹⁾	I/O Level ⁽²⁾	Main function ⁽³⁾ (after reset)	Alternate functions
LQFP144	UFBGA132	LQFP100	LQFP64	WLCSP64					
50	J7	-	-	-	PF12	I/O	FT	PF12	ADC_IN2b/COMP1_INP/FSMC_A6
51	E3	-	-	-	V _{SS_6}	S		V _{SS_6}	
52	H3	-	-	-	V _{DD_6}	S		V _{DD_6}	
53	K7	-	-	-	PF13	I/O	FT	PF13	ADC_IN3b/COMP1_INP/FSMC_A7
54	J8	-	-	-	PF14	I/O	FT	PF14	ADC_IN6b/COMP1_INP/FSMC_A8
55	J9	-	-	-	PF15	I/O	FT	PF15	ADC_IN7b/COMP1_INP/FSMC_A9
56	H9	-	-	-	PG0	I/O	FT	PG0	ADC_IN8b/COMP1_INP/FSMC_A10
57	G9	-	-	-	PG1	I/O	FT	PG1	FSMC_A6/ADC_IN9b/COMP1_INP/FSMC_A11
58	M7	38	-	-	PE7	I/O		PE7	FSMC_D4/ ADC_IN22/COMP1_INP
59	L7	39	-	-	PE8	I/O		PE8	FSMC_D5/ADC_IN23/COMP1_INP
60	M8	40	-	-	PE9	I/O		PE9	TIM2_CH1_ETR/FSMC_D6/ ADC_IN24/COMP1_INP
61	-	-	-	-	V _{SS_7}	S		V _{SS_7}	
62	-	-	-	-	V _{DD_7}	S		V _{DD_7}	
63	L8	41	-	-	PE10	I/O		PE10	TIM2_CH2/ FSMC_D7/ADC_IN25/COMP1_INP
64	M9	42	-	-	PE11	I/O	FT	PE11	TIM2_CH3/FSMC_D8
65	L9	43	-	-	PE12	I/O	FT	PE12	TIM2_CH4/SPI1_NSS/FSMC_D9
66	M1 0	44	-	-	PE13	I/O	FT	PE13	SPI1_SCK/FSMC_D10
67	M1 1	45	-	-	PE14	I/O	FT	PE14	SPI1_MISO/FSMC_D11
68	M1 2	46	-	-	PE15	I/O	FT	PE15	SPI1_MOSI/FSMC_D12
69	L10	47	29	G3	PB10	I/O	FT	PB10	TIM2_CH3/I2C2_SCL/USART3_TX/LCD_SEG10
70	L11	48	30	F3	PB11	I/O	FT	PB11	TIM2_CH4/I2C2_SDA/ USART3_RX/LCD_SEG11
71	F12	49	31	H2	V _{SS_1}	S		V _{SS_1}	
72	G1 2	50	32	H1	V _{DD_1}	S		V _{DD_1}	
73	L12	51	33	G2	PB12	I/O	FT	PB12	TIM10_CH1/I2C2_SMBA/SPI2_NSS/I2S2_WS/ USART3_CK/ LCD_SEG12/ADC_IN18/COMP1_INP
74	K12	52	34	G1	PB13	I/O	FT	PB13	TIM9_CH1/SPI2_SCK/ I2S2_CK/ USART3_CTS/ LCD_SEG13/ADC_IN19/COMP1_INP
75	K11	53	35	F2	PB14	I/O	FT	PB14	TIM9_CH2/SPI2_MISO/ USART3_RTS/LCD_SEG14/ ADC_IN20/COMP1_INP
76	K10	54	36	F1	PB15	I/O	FT	PB15	TIM11_CH1/SPI2_MOSI/I2S2_SD/LCD_SEG15/ ADC_IN21/COMP1_INP/RTC_50_60Hz
77	K9	55	-	-	PD8	I/O	FT	PD8	USART3_TX/LCD_SEG28/FSMC_D13
78	K8	56	-	-	PD9	I/O	FT	PD9	USART3_RX/LCD_SEG29/FSMC_D14
79	J12	57	-	-	PD10	I/O	FT	PD10	USART3_CK/LCD_SEG30/FSMC_D15

Table 8. STM32L15xxD pin definitions (continued)

Pins					Pin name	Type ⁽¹⁾	I/O Level ⁽²⁾	Main function ⁽³⁾ (after reset)	Alternate functions
LQFP144	UFBGA132	LQFP100	LQFP64	WLCSP64					
80	J11	58	-	-	PD11	I/O	FT	PD11	USART3_CTS/LCD_SEG31/FSMC_A16
81	J10	59	-	-	PD12	I/O	FT	PD12	TIM4_CH1 / USART3_RTS/LCD_SEG32/FSMC_A17
82	H12	60	-	-	PD13	I/O	FT	PD13	TIM4_CH2/LCD_SEG33/FSMC_A18
83	-	-	-	-	V _{SS_8}	S		V _{SS_8}	
84	-	-	-	-	V _{DD_8}	S		V _{DD_8}	
85	H11	61	-	-	PD14	I/O	FT	PD14	TIM4_CH3/LCD_SEG34/FSMC_D0
86	H10	62	-	-	PD15	I/O	FT	PD15	TIM4_CH4/LCD_SEG35/FSMC_D1
87	G10	-	-	-	PG2	I/O	FT	PG2	FSMC_A12/ADC_IN10b/COMP1_INP
88	F9	-	-	-	PG3	I/O	FT	PG3	FSMC_A13/ADC_IN11b/COMP1_INP
89	F10	-	-	-	PG4	I/O	FT	PG4	FSMC_A14/ADC_IN12b/COMP1_INP
90	E9	-	-	-	PG5	I/O	FT	PG5	FSMC_A15
91	-	-	-	-	PG6	I/O	FT	PG6	
92	-	-	-	-	PG7	I/O	FT	PG7	
93	-	-	-	-	PG8	I/O	FT	PG8	
94	F6	-	-	-	V _{SS_9}	S		V _{SS_9}	
95	G6	-	-	-	V _{DD_9}	S		V _{DD_9}	
96	E12	63	37	E1	PC6	I/O	FT	PC6	TIM3_CH1/I2S2_MCK/LCD_SEG24/FSMC_D6/ SDIO_D6
97	E11	64	38	E2	PC7	I/O	FT	PC7	TIM3_CH2/I2S3_MCK/LCD_SEG25/FSMC_D7/ SDIO_D7
98	E10	65	39	E3	PC8	I/O	FT	PC8	TIM3_CH3/LCD_SEG26/FSMC_D0/SDIO_D0
99	D12	66	40	D1	PC9	I/O	FT	PC9	TIM3_CH4/LCD_SEG27/FSMC_D1/SDIO_D1
100	D11	67	41	E4	PA8	I/O	FT	PA8	USART1_CK/MCO/LCD_COM0
101	D10	68	42	D2	PA9	I/O	FT	PA9	USART1_TX / LCD_COM1
102	C12	69	43	D3	PA10	I/O	FT	PA10	USART1_RX / LCD_COM2
103	B12	70	44	C1	PA11	I/O	FT	PA11	USART1_CTS/ USB_DM/SPI1_MISO
104	A12	71	45	C2	PA12	I/O	FT	PA12	USART1_RTS/USB_DP/SPI1_MOSI
105	A11	72	46	D4	PA13	I/O	FT	JTMS-SWDIO	PA13
106	C11	73	-	-	PH2	I/O	FT	PH2	FSMC_A22
107	F11	74	47	B1	V _{SS_2}	S		V _{SS_2}	
108	G11	75	48	A1	V _{DD_2}	S		V _{DD_2}	
109	A10	76	49	B2	PA14	I/O	FT	JTCK-SWCLK	PA14
110	A9	77	50	C3	PA15	I/O	FT	JTDI	TIM2_CH1_ETR/ SPI1_NSS/SPI3_NSS/ I2S3_WS/LCD_SEG17

Table 8. STM32L15xxD pin definitions (continued)

Pins					Pin name	Type ⁽¹⁾	I/O Level ⁽²⁾	Main function ⁽³⁾ (after reset)	Alternate functions
LQFP144	UFBGA132	LQFP100	LQFP64	WLCSP64					
111	B11	78	51	A2	PC10	I/O	FT	PC10	SPI3_SCK/I2S3_CK/USART3_TX/ UART4_TX/ LCD_SEG28/LCD_SEG40/LCD_COM4/FSMC_D2/ SDIO_D2
112	C10	79	52	B3	PC11	I/O	FT	PC11	SPI3_MISO/USART3_RX/UART4_RX/ LCD_SEG29/LCD_SEG41/LCD_COM5/FSMC_D3/ SDIO_D3
113	B10	80	53	C4	PC12	I/O	FT	PC12	SPI3_MOSI/I2S3_SD/USART3_CK/ UART5_TX/ LCD_SEG30/ LCD_SEG42/LCD_COM6/SDIO_CK
114	C9	81	-	-	PD0	I/O	FT	PD0	TIM9_CH1/SPI2_NSS/I2S2_WS/ FSMC_D2
115	B9	82	-	-	PD1	I/O	FT	PD1	SPI2_SCK/I2S2_CK/FSMC_D3
116	C8	83	54	A3	PD2	I/O	FT	PD2	TIM3_ETR/UART5_RX/LCD_SEG31/LCD_SEG43/ LCD_COM7/SDIO_CMD
117	B8	84	-	-	PD3	I/O	FT	PD3	SPI2_MISO/USART2_CTS/FSMC_CLK
118	B7	85	-	-	PD4	I/O	FT	PD4	SPI2_MOSI/I2S2_SD/ USART2_RTS/FSMC_NOE
119	A6	86	-	-	PD5	I/O	FT	PD5	USART2_TX/FSMC_NWE
120	F7	-	-	-	V _{SS_10}	S		V _{SS_10}	
121	G7	-	-	-	V _{DD_10}	S		V _{DD_10}	
122	B6	87	-	-	PD6	I/O	FT	PD6	USART2_RX/FSMC_NWAIT
123	A5	88	-	-	PD7	I/O	FT	PD7	TIM9_CH2/USART2_CK/FSMC_EBAR0
124	D9	-	-	-	PG9	I/O	FT	PG9	FSMC_EBAR1
125	D8	-	-	-	PG10	I/O	FT	PG10	FSMC_EBAR2
126	-	-	-	-	PG11	I/O	FT	PG11	
127	D7	-	-	-	PG12	I/O	FT	PG12	FSMC_EBAR3
128	C7	-	-	-	PG13	I/O	FT	PG13	FSMC_A24
129	C6	-	-	-	PG14	I/O	FT	PG14	FSMC_A25
130	-	-	-	-	V _{SS_11}	S		V _{SS_11}	
131	-	-	-	-	V _{DD_11}	S		V _{DD_11}	
132	-	-	-	-	PG15	I/O	FT	PG15	
133	A8	89	55	A4	PB3	I/O	FT	JTDO	TIM2_CH2/SPI1_SCK/SPI3_SCK/ I2S3_CK/ LCD_SEG7/COMP2_INM/TRACESWO
134	A7	90	56	B4	PB4	I/O	FT	NJTRST	TIM3_CH1/ SPI1_MISO/SPI3_MISO/LCD_SEG8/ COMP2_INP
135	C5	91	57	A5	PB5	I/O	FT	PB5	TIM3_CH2 /I2C1_SMBA/SPI1_MOSI/SPI3_MOSI/ I2S3_SD/LCD_SEG9/COMP2_INP
136	B5	92	58	B5	PB6	I/O	FT	PB6	TIM4_CH1/I2C1_SCL/USART1_TX/COMP2_INP
137	B4	93	59	C5	PB7	I/O	FT	PB7	TIM4_CH2/I2C1_SDA/USART1_RX/PVD_IN/ FSMC_NADV/ COMP2_INP
138	A4	94	60	A6	BOOT0	I		BOOT0	

Table 8. STM32L15xxD pin definitions (continued)

Pins					Pin name	Type ⁽¹⁾	I/O Level ⁽²⁾	Main function ⁽³⁾ (after reset)	Alternate functions
LQFP144	UFBGA132	LQFP100	LQFP64	WLCSP64					
139	A3	95	61	D5	PB8	I/O	FT	PB8	TIM4_CH3/TIM10_CH1/I2C1_SCL/LCD_SEG16/ FSMC_D4/SDIO_D4
140	B3	96	62	B6	PB9	I/O	FT	PB9	TIM4_CH4/TIM11_CH1/I2C1_SDA/LCD_COM3/ FSMC_D5/SDIO_D5
141	C3	97	-	-	PE0	I/O	FT	PE0	TIM4_ETR/TIM10_CH1/LCD_SEG36/FSMC_NBL0
142	A2	98	-	-	PE1	I/O	FT	PE1	TIM11_CH1/LCD_SEG37/FSMC_NBL1
143	D3	99	63	A7	V _{SS_3}	S		V _{SS_3}	
144	C4	100	64	A8	V _{DD_3}	S		V _{DD_3}	

1. I = input, O = output, S = supply.
2. FT = 5 V tolerant.
3. Function availability depends on the chosen device.
4. Applicable to STM32L152xD devices only. In STM32L151xD devices, this pin should be connected to V_{DD}.
5. The PC14 and PC15 I/Os are only configured as OSC32_IN/OSC32_OUT when the LSE oscillator is ON (by setting the LSEON bit in the RCC_CSR register). The LSE oscillator pins OSC32_IN/OSC32_OUT can be used as general-purpose PH0/PH1 I/Os, respectively, when the LSE oscillator is off (after reset, the LSE oscillator is off). The LSE has priority over the GPIO function. For more details, refer to Using the OSC32_IN/OSC32_OUT pins as GPIO PC14/PC15 port pins section in the STM32L151xx, STM32L152xx and STM32L162xx reference manual (RM0038).
6. The PH0 and PH1 I/Os are only configured as OSC_IN/OSC_OUT when the HSE oscillator is ON (by setting the HSEON bit in the RCC_CR register). The HSE oscillator pins OSC_IN/OSC_OUT can be used as general-purpose PH0/PH1 I/Os, respectively, when the HSE oscillator is off (after reset, the HSE oscillator is off). The HSE has priority over the GPIO function.



Table 9. Alternate function input/output

Port name	Digital alternate function number															
	AFIO0	AFIO1	AFIO2	AFIO3	AFIO4	AFIO5	AFIO6	AFIO7	AFIO8	..	AFIO10	AFIO11	AFIO12	..	AFIO14	AFIO15
	Alternate function															
	SYSTEM	TIM2	TIM3/4/5	TIM9/10/11	I2C1/2	SPI1/2	SPI3	USART1/2/3	UART4/5	USB	LCD	FSMC/SDIO	CPRI	SYSTEM		
BOOT0	BOOT0															EVENT OUT
NRST	NRST															
PA0-WKUP1	WKUP1/TAMPER2	TIM2_CH1_ETR	TIM5_CH1					USART2_CTS							COMP1_INP/TIMx_IC1_0/G1IO1	EVENT OUT
PA1		TIM2_CH2	TIM5_CH2					USART2_RTS			SEG0			COMP1_INP/TIMx_IC2_0/G1IO2	EVENT OUT	
PA2		TIM2_CH3	TIM5_CH3	TIM9_CH1				USART2_TX			SEG1			COMP1_INP/TIMx_IC3_0/G1IO3	EVENT OUT	
PA3		TIM2_CH4	TIM5_CH4	TIM9_CH2				USART2_RX			SEG2			COMP1_INP/TIMx_IC4_0/G1IO4	EVENT OUT	
PA4						SPI1_NSS	SPI3_NSS/I2S3_WS	USART2_CK						COMP1_INP/TIMx_IC1_1	EVENT OUT	
PA5		TIM2_CH1_ETR*				SPI1_SCK								COMP1_INP/TIMx_IC2_1	EVENT OUT	
PA6			TIM3_CH1	TIM10_CH1		SPI1_MISO					SEG3			COMP1_INP/TIMx_IC3_1/G2IO1	EVENT OUT	
PA7			TIM3_CH2	TIM11_CH1		SPI1_MOSI					SEG4			COMP1_INP/TIMx_IC4_1/G2IO2	EVENT OUT	
PA8	MCO							USART1_CK			COM0			TIMx_IC1_2/G4IO1	EVENT OUT	
PA9								USART1_TX			COM1			TIMx_IC2_2/G4IO2	EVENT OUT	
PA10								USART1_RX			COM2			TIMx_IC3_2/G4IO3	EVENT OUT	

Table 9. Alternate function input/output (continued)

Port name	Digital alternate function number																
	AFIO0	AFIO1	AFIO2	AFIO3	AFIO4	AFIO5	AFIO6	AFIO7	AFIO8	..	AFIO10	AFIO11	AFIO12	..	AFIO14	AFIO15	
	Alternate function																
	SYSTEM	TIM2	TIM3/4/5	TIM9/10/11	I2C1/2	SPI1/2	SPI3	USART1/2/3	UART4/5		USB	LCD	FSMC/SDIO		CPRI	SYSTEM	
PA11						SPI1_MISO		USART1_CTS			USBDM				TIMx_IC4_2/ G4IO4	EVENT OUT	
PA12						SPI1_MOSI		USART1_RTS			USBDP				TIMx_IC1_3/	EVENT OUT	
PA13	JTMS-SWDIO														TIMx_IC2_3/ G5IO1	EVENT OUT	
PA14	JTCK-SWCLK														TIMx_IC3_3/ G5IO2	EVEN TOUT	
PA15	JTDI	TIM2_CH1_ETR				SPI1_NSS	SPI3_NSS I2S3_WS					SEG17			TIMx_IC4_3/ G5IO3	EVEN TOUT	
PB0			TIM3_CH3									SEG5			COMP1_INP/ G3IO1	EVEN TOUT	
PB1			TIM3_CH4									SEG6			COMP1_INP/ G3IO2	EVENT OUT	
PB2	BOOT1														COMP1_INP/ G3IO3	EVENT OUT	
PB3	JTDO	TIM2_CH2				SPI1_SCK	SPI3_SCK I2S3_CK					SEG7					EVENT OUT
PB4	JTRST		TIM3_CH1			SPI1_MISO	SPI3_MISO					SEG8			G6IO1	EVENT OUT	
PB5			TIM3_CH2		I2C1_ SMBA	SPI1_MOSI	SPI3_MOSI I2S3_SD					SEG9			G6IO2	EVENT OUT	
PB6			TIM4_CH1		I2C1_SCL			USART1_TX							G6IO3	EVENT OUT	
PB7			TIM4_CH2		I2C1_SDA			USART1_RX					NADV		G6IO4	EVENT OUT	
PB8			TIM4_CH3	TIM10_ CH1	I2C1_SCL							SEG16	SDIO_D4			EVENT OUT	
PB9			TIM4_CH4	TIM11_ CH1	I2C1_SDA							COM3	SDIO_D5			EVENT OUT	



Table 9. Alternate function input/output (continued)

Port name	Digital alternate function number															
	AFIO0	AFIO1	AFIO2	AFIO3	AFIO4	AFIO5	AFIO6	AFIO7	AFIO8	..	AFIO10	AFIO11	AFIO12	..	AFIO14	AFIO15
	Alternate function															
	SYSTEM	TIM2	TIM3/4/5	TIM9/10/11	I2C1/2	SPI1/2	SPI3	USART1/2/3	UART4/5	USB	LCD	FSMC/SDIO	CPRI	SYSTEM		
PB10		TIM2_CH3			I2C2_SCL			USART3_TX				SEG10				EVENT OUT
PB11		TIM2_CH4			I2C2_SDA			USART3_RX				SEG11				EVENT OUT
PB12				TIM10_CH1	I2C2_SMBAL	SPI2_NSS I2S2_WS		USART3_CK				SEG12		COMP1_INP/ G7IO1		EVENT OUT
PB13				TIM9_CH1		SPI2_SCK I2S2_CK		USART3_CTS				SEG13		COMP1_INP/ G7IO2		EVENT OUT
PB14				TIM9_CH2		SPI2_MISO		USART3_RTS				SEG14		COMP1_INP/ G7IO3		EVENT OUT
PB15	RTC 50/60 Hz			TIM11_CH1		SPI2_MOSI I2S2_SD						SEG15		COMP1_INP/ G7IO4		EVENT OUT
PC0												SEG18		COMP1_INP/ TIMx_IC1_4/ G8IO1		EVENT OUT
PC1												SEG19		COMP1_INP/ TIMx_IC2_4/ G8IO2		EVENT OUT
PC2												SEG20		COMP1_INP/ TIMx_IC3_4/ G8IO3		EVENT OUT
PC3												SEG21		COMP1_INP/ TIMx_IC4_4/ G8IO4		EVENT OUT
PC4												SEG22		COMP1_INP/ TIMx_IC1_5/ G9IO1		EVENT OUT
PC5												SEG23		COMP1_INP/ TIMx_IC2_5/ G9IO2		EVENT OUT
PC6			TIM3_CH1			I2S2_MCK						SEG24	SDIO_D6	TIMx_IC3_5/ G10IO1		EVENT OUT

Table 9. Alternate function input/output (continued)

Port name	Digital alternate function number															
	AFIO0	AFIO1	AFIO2	AFIO3	AFIO4	AFIO5	AFIO6	AFIO7	AFIO8	..	AFIO10	AFIO11	AFIO12	..	AFIO14	AFIO15
	Alternate function															
	SYSTEM	TIM2	TIM3/4/5	TIM9/10/11	I2C1/2	SPI1/2	SPI3	USART1/2/3	UART4/5	USB	LCD	FSMC/SDIO	CPRI	SYSTEM		
PC7			TIM3_CH2				I2S3_MCK				SEG25	SDIO_D7	TIMx_IC4_5/ G10IO2	EVENT OUT		
PC8			TIM3_CH3								SEG26	SDIO_D0	TIMx_IC1_6/ G10IO3	EVENT OUT		
PC9			TIM3_CH4								SEG27	SDIO_D1	TIMx_IC2_6/ G10IO4	EVENT OUT		
PC10							SPI3_SCK I2S3_CK	USART3_TX	UART4_TX		COM4/ SEG28/ SEG40	SDIO_D2	TIMx_IC3_6/ G5IO4	EVENT OUT		
PC11							SPI3_MISO	USART3_RX	UART4_RX		COM5/ SEG29 /SEG41	SDIO_D3	TIMx_IC4_6	EVENT OUT		
PC12							SPI3_MOSI I2S3_SD	USART3_CK	UART5_TX		COM6/ SEG30/ SEG42	SDIO_CK	TIMx_IC1_7	EVENT OUT		
PC13- WKUP2	WKUP2/ TAMPER1/ TIMESTAMP/ ALARM_OUT/ 512Hz												TIMx_IC2_7	EVENT OUT		
PC14 OSC32_I N	OSC32_IN												TIMx_IC3_7	EVENT OUT		
PC15 OSC32_ OUT	OSC32_OUT												TIMx_IC4_7	EVENT OUT		
PD0				TIM9_CH1		SPI2_NSS I2S2_WS						D2 / DA2	TIMx_IC1_8	EVENT OUT		
PD1						SPI2_SCK I2S2_CK						D3 / DA3	TIMx_IC2_8	EVENT OUT		
PD2			TIM3_ETR						UART5_RX		COM7/ SEG31/ SEG43	SDIO_ CMD	TIMx_IC3_8	EVENT OUT		



Table 9. Alternate function input/output (continued)

Port name	Digital alternate function number															
	AFIO0	AFIO1	AFIO2	AFIO3	AFIO4	AFIO5	AFIO6	AFIO7	AFIO8	..	AFIO10	AFIO11	AFIO12	..	AFIO14	AFIO15
	Alternate function															
	SYSTEM	TIM2	TIM3/4/5	TIM9/10/11	I2C1/2	SPI1/2	SPI3	USART1/2/3	UART4/5	USB	LCD	FSMC/SDIO	CPRI	SYSTEM		
PD3						SPI2_MISO		USART2_CTS				CLK	TIMx_IC4_8	EVENT OUT		
PD4						SPI2_MOSI I2S2_SD		USART2_RTS				OEN	TIMx_IC1_9	EVENT OUT		
PD5								USART2_TX				WEN	TIMx_IC2_9	EVENT OUT		
PD6								USART2_RX				WAITN	TIMx_IC3_9	EVENT OUT		
PD7				TIM9_CH2				USART2_CK				EBAR0	TIMx_IC4_9	EVENT OUT		
PD8								USART3_TX			SEG28	D13/DA13	TIMx_IC1_10	EVENT OUT		
PD9								USART3_RX			SEG29	D14/DA14	TIMx_IC2_10	EVENT OUT		
PD10								USART3_CK			SEG30	D15/DA15	TIMx_IC3_10	EVENT OUT		
PD11								USART3_CTS			SEG31	A16	TIMx_IC4_10	EVENT OUT		
PD12			TIM4_CH1					USART3_RTS			SEG32	A17	TIMx_IC1_11	EVENT OUT		
PD13			TIM4_CH2								SEG33	A18	TIMx_IC2_11	EVENT OUT		
PD14			TIM4_CH3								SEG34	D0/DA0	TIMx_IC3_11	EVENT OUT		
PD15			TIM4_CH4								SEG35	D1/DA1	TIMx_IC4_11	EVENT OUT		
PE0			TIM4_ETR	TIM10_CH1							SEG36	BLN0	TIMx_IC1_12	EVENT OUT		
PE1				TIM11_CH1							SEG37	BLN1	TIMx_IC2_12	EVENT OUT		

Table 9. Alternate function input/output (continued)

Port name	Digital alternate function number															
	AFIO0	AFIO1	AFIO2	AFIO3	AFIO4	AFIO5	AFIO6	AFIO7	AFIO8	..	AFIO10	AFIO11	AFIO12	..	AFIO14	AFIO15
	Alternate function															
	SYSTEM	TIM2	TIM3/4/5	TIM9/10/11	I2C1/2	SPI1/2	SPI3	USART1/2/3	UART4/5	USB	LCD	FSMC/SDIO	CPRI	SYSTEM		
PE2	TRACECK		TIM3_ETR								SEG 38	A23	TIMx_IC3_12	EVENT OUT		
PE3	TRACED0		TIM3_CH1								SEG 39	A19	TIMx_IC4_12	EVENT OUT		
PE4	TRACED1		TIM3_CH2									A20	TIMx_IC1_13	EVENT OUT		
PE5	TRACED2			TIM9_CH1								A21	TIMx_IC2_13	EVENT OUT		
PE6-WKUP3	WKUP3/ TAMPER3 / TRACED3			TIM9_CH2									TIMx_IC3_13	EVENT OUT		
PE7												D4/DA4	COMP1_INP/ TIMx_IC4_13	EVENT OUT		
PE8												D5/DA5	COMP1_INP/ TIMx_IC1_14	EVENT OUT		
PE9		TIM2_CH1_ETR										D6/DA6	COMP1_INP/ TIMx_IC2_14	EVENT OUT		
PE10		TIM2_CH2										D7/DA7	COMP1_INP/ TIMx_IC3_14	EVENT OUT		
PE11		TIM2_CH3										D8/DA8	TIMx_IC4_14	EVENT OUT		
PE12		TIM2_CH4				SPI1_NSS						D9/DA9	TIMx_IC1_15	EVENT OUT		
PE13						SPI1_SCK						D10/DA10	TIMx_IC2_15	EVENT OUT		
PE14						SPI1_MISO						D11/DA11	TIMx_IC3_15	EVENT OUT		
PE15						SPI1_MOSI						D12/DA12	TIMx_IC4_15	EVENT OUT		
PF0												A0		EVENT OUT		



Table 9. Alternate function input/output (continued)

Port name	Digital alternate function number															
	AFIO0	AFIO1	AFIO2	AFIO3	AFIO4	AFIO5	AFIO6	AFIO7	AFIO8	..	AFIO10	AFIO11	AFIO12	..	AFIO14	AFIO15
	Alternate function															
	SYSTEM	TIM2	TIM3/4/5	TIM9/10/11	I2C1/2	SPI1/2	SPI3	USART1/2/3	UART4/5	USB	LCD	FSMC/SDIO	CPRI	SYSTEM		
PF1												A1				EVENT OUT
PF2												A2				EVENT OUT
PF3												A3				EVENT OUT
PF4												A4				EVENT OUT
PF5												A5				EVENT OUT
PF6			TIM5_CH1 ETR										COMP1_INP G11IO1			EVENT OUT
PF7			TIM5_CH2										COMP1_INP G11IO2			EVENT OUT
PF8			TIM5_CH3										COMP1_INP G11IO3			EVENT OUT
PF9			TIM5_CH4										COMP1_INP G11IO4			EVENT OUT
PF10													COMP1_INP G11IO5			EVENT OUT
PF11													COMP1_INP G3IO4			EVENT OUT
PF12												A6	G3IO5			EVENT OUT
PF13												A7	G9IO3			EVENT OUT
PF14												A8	G9IO4			EVENT OUT
PF15												A9	G2IO3			EVENT OUT

Table 9. Alternate function input/output (continued)

Port name	Digital alternate function number															
	AFIO0	AFIO1	AFIO2	AFIO3	AFIO4	AFIO5	AFIO6	AFIO7	AFIO8	..	AFIO10	AFIO11	AFIO12	..	AFIO14	AFIO15
	Alternate function															
	SYSTEM	TIM2	TIM3/4/5	TIM9/10/11	I2C1/2	SPI1/2	SPI3	USART1/2/3	UART4/5	USB	LCD	FSMC/SDIO	CPRI	SYSTEM		
PG0												A10	G2IO4	EVENT OUT		
PG1												A11	G2IO5	EVENT OUT		
PG2												A12	G7IO5	EVENT OUT		
PG3												A13	G7IO6	EVENT OUT		
PG4												A14	G7IO7	EVENT OUT		
PG5												A15		EVENT OUT		
PG6														EVENT OUT		
PG7														EVENT OUT		
PG8														EVENT OUT		
PG9												EBAR1		EVENT OUT		
PG10												EBAR2		EVENT OUT		
PG11														EVENT OUT		
PG12												EBAR3		EVENT OUT		
PG13												A24		EVENT OUT		
PG14												A25		EVENT OUT		

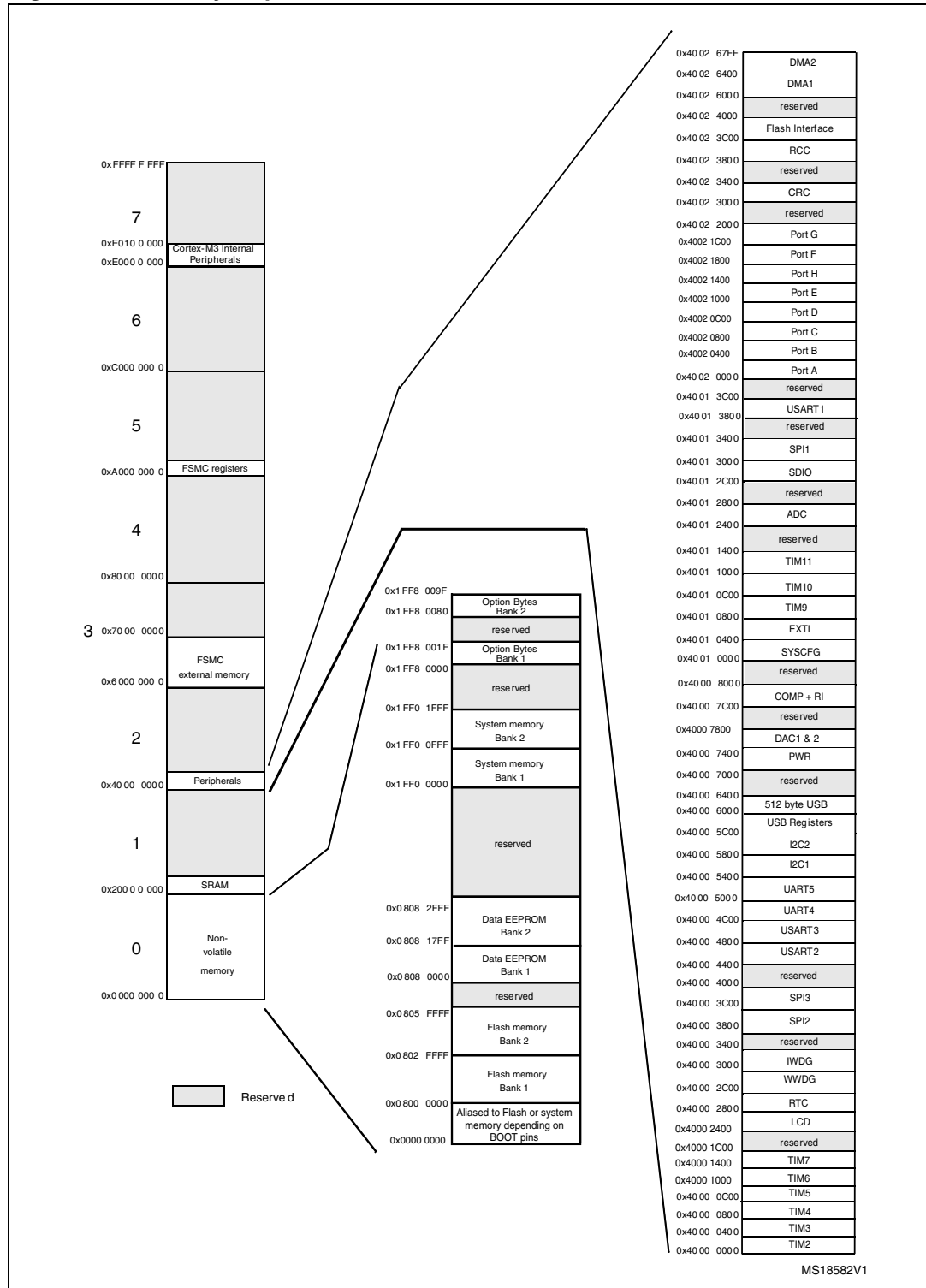

Table 9. Alternate function input/output (continued)

Port name	Digital alternate function number																
	AFIO0	AFIO1	AFIO2	AFIO3	AFIO4	AFIO5	AFIO6	AFIO7	AFIO8	..	AFIO10	AFIO11	AFIO12	..	AFIO14	AFIO15	
	Alternate function																
	SYSTEM	TIM2	TIM3/4/5	TIM9/10/11	I2C1/2	SPI1/2	SPI3	USART1/2/3	UART4/5		USB	LCD	FSMC/SDIO		CPRI	SYSTEM	
PG15																	EVENT OUT
PH0OSC_IN	OSC_IN																
PH1OSC_OUT	OSC_OUT																
PH2													A22				

5 Memory mapping

Figure 6. Memory map



6 Electrical characteristics

6.1 Parameter conditions

Unless otherwise specified, all voltages are referenced to V_{SS} .

6.1.1 Minimum and maximum values

Unless otherwise specified the minimum and maximum values are guaranteed in the worst conditions of ambient temperature, supply voltage and frequencies by tests in production on 100% of the devices with an ambient temperature at $T_A = 25\text{ °C}$ and $T_A = T_{A\text{max}}$ (given by the selected temperature range).

Data based on characterization results, design simulation and/or technology characteristics are indicated in the table footnotes and are not tested in production. Based on characterization, the minimum and maximum values refer to sample tests and represent the mean value plus or minus three times the standard deviation ($\text{mean} \pm 3\Sigma$).

6.1.2 Typical values

Unless otherwise specified, typical data are based on $T_A = 25\text{ °C}$, $V_{DD} = 3.6\text{ V}$ (for the $1.65\text{ V} \leq V_{DD} \leq 3.6\text{ V}$ voltage range). They are given only as design guidelines and are not tested.

Typical ADC accuracy values are determined by characterization of a batch of samples from a standard diffusion lot over the full temperature range, where 95% of the devices have an error less than or equal to the value indicated ($\text{mean} \pm 2\Sigma$).

6.1.3 Typical curves

Unless otherwise specified, all typical curves are given only as design guidelines and are not tested.

6.1.4 Loading capacitor

The loading conditions used for pin parameter measurement are shown in [Figure 7](#).

6.1.5 Pin input voltage

The input voltage measurement on a pin of the device is described in [Figure 8](#).

Figure 7. Pin loading conditions

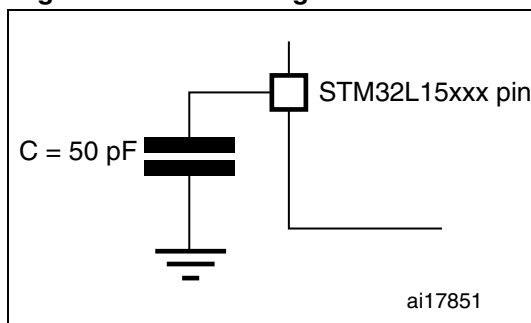
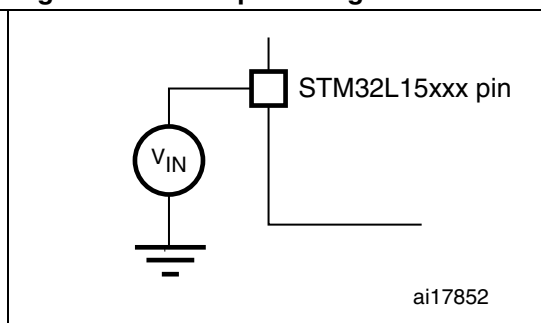
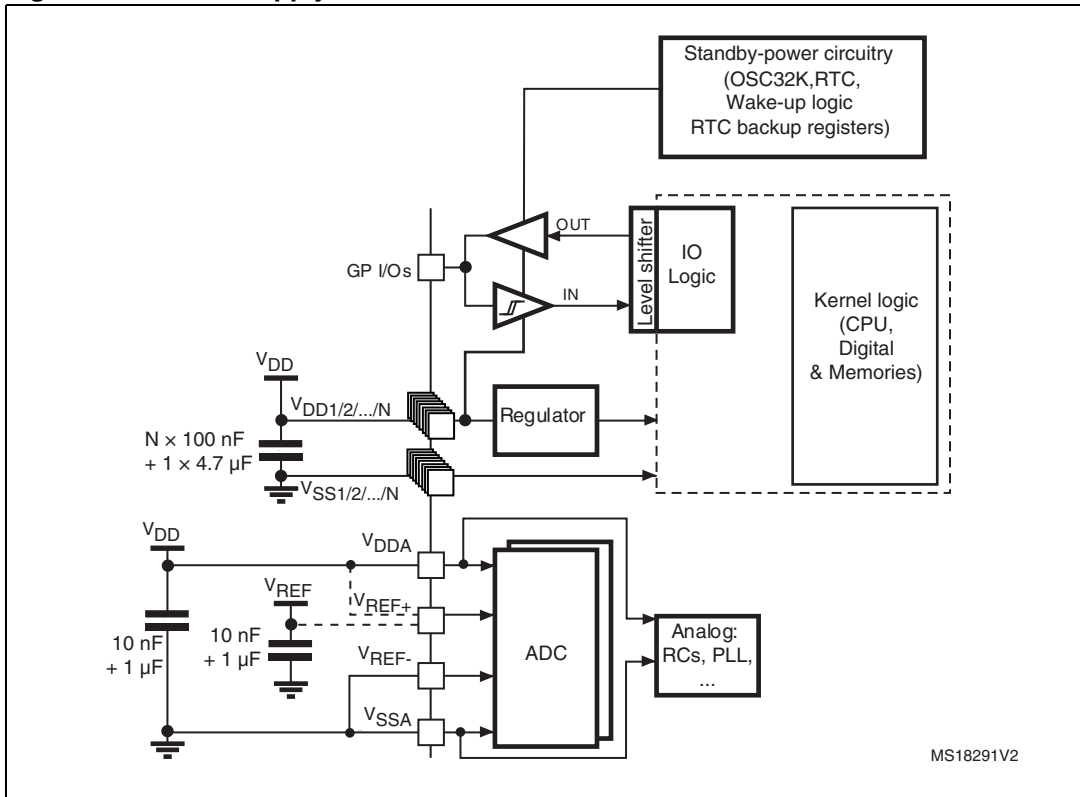

Figure 8. Pin input voltage



6.1.6 Power supply scheme

Figure 9. Power supply scheme



6.1.7 Current consumption measurement

Figure 10. Current consumption measurement scheme

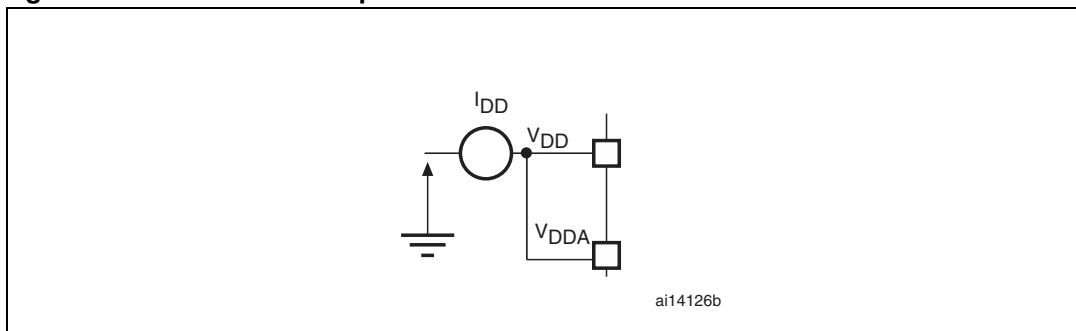

6.2 Absolute maximum ratings

Stresses above the absolute maximum ratings listed in [Table 10: Voltage characteristics](#), [Table 11: Current characteristics](#), and [Table 12: Thermal characteristics](#) may cause permanent damage to the device. These are stress ratings only and functional operation of the device at these conditions is not implied. Exposure to maximum rating conditions for extended periods may affect device reliability.

Table 10. Voltage characteristics

Symbol	Ratings	Min	Max	Unit
$V_{DD}-V_{SS}$	External main supply voltage (including V_{DDA} and V_{DD}) ⁽¹⁾	-0.3	4.0	V
V_{IN} ⁽²⁾	Input voltage on five-volt tolerant pin	$V_{SS} - 0.3$	$V_{DD}+4.0$	
	Input voltage on any other pin	$V_{SS} - 0.3$	4.0	
$ \Delta V_{DDX} $	Variations between different V_{DD} power pins		50	mV
$ V_{SSX} - V_{SS} $	Variations between all different ground pins		50	
$V_{ESD(HBM)}$	Electrostatic discharge voltage (human body model)	see Section 6.3.11		

1. All main power (V_{DD} , V_{DDA}) and ground (V_{SS} , V_{SSA}) pins must always be connected to the external power supply, in the permitted range.
2. V_{IN} maximum must always be respected. Refer to [Table 11](#) for maximum allowed injected current values.

Table 11. Current characteristics

Symbol	Ratings	Max.	Unit
I_{VDD}	Total current into V_{DD}/V_{DDA} power lines (source) ⁽¹⁾	80	mA
I_{VSS}	Total current out of V_{SS} ground lines (sink) ⁽¹⁾	80	
I_{IO}	Output current sunk by any I/O and control pin	25	
	Output current sourced by any I/O and control pin	- 25	
$I_{INJ(PIN)}$ ⁽²⁾	Injected current on five-volt tolerant I/O ⁽³⁾	+0 /-5	
	Injected current on any other pin ⁽⁴⁾	± 5	
$\Sigma I_{INJ(PIN)}$	Total injected current (sum of all I/O and control pins) ⁽⁵⁾	± 25	

1. All main power (V_{DD} , V_{DDA}) and ground (V_{SS} , V_{SSA}) pins must always be connected to the external power supply, in the permitted range.
2. Negative injection disturbs the analog performance of the device. See note in [Section 6.3.17](#).
3. Positive current injection is not possible on these I/Os. A negative injection is induced by $V_{IN} < V_{SS}$. $I_{INJ(PIN)}$ must never be exceeded. Refer to [Table 10](#) for maximum allowed input voltage values.
4. A positive injection is induced by $V_{IN} > V_{DD}$ while a negative injection is induced by $V_{IN} < V_{SS}$. $I_{INJ(PIN)}$ must never be exceeded. Refer to [Table 10: Voltage characteristics](#) for the maximum allowed input voltage values.
5. When several inputs are submitted to a current injection, the maximum $\Sigma I_{INJ(PIN)}$ is the absolute sum of the positive and negative injected currents (instantaneous values).

Table 12. Thermal characteristics

Symbol	Ratings	Value	Unit
T_{STG}	Storage temperature range	-65 to +150	°C
T_J	Maximum junction temperature	150	°C

6.3 Operating conditions

6.3.1 General operating conditions

Table 13. General operating conditions

Symbol	Parameter	Conditions	Min	Max	Unit
f_{HCLK}	Internal AHB clock frequency		0	32	MHz
f_{PCLK1}	Internal APB1 clock frequency		0	32	
f_{PCLK2}	Internal APB2 clock frequency		0	32	
V_{DD}	Standard operating voltage	BOR detector disabled	1.65	3.6	V
		BOR detector enabled, at power on	1.8	3.6	
		BOR detector disabled, after power on	1.65	3.6	
$V_{DDA}^{(1)}$	Analog operating voltage (ADC and DAC not used)	Must be the same voltage as $V_{DD}^{(2)}$	1.65	3.6	V
	Analog operating voltage (ADC or DAC used)		1.8	3.6	
P_D	Power dissipation at $T_A = 85\text{ °C}^{(3)}$			290	mW
T_A	Temperature range	Maximum power dissipation	-40	85	°C
		Low power dissipation ⁽⁴⁾	-40	105	
T_J	Junction temperature range	$-40\text{ °C} \leq T_A \leq 105\text{ °C}$	-40	105	°C

1. When the ADC is used, refer to [Table 62: ADC characteristics](#).
2. It is recommended to power V_{DD} and V_{DDA} from the same source. A maximum difference of 300 mV between V_{DD} and V_{DDA} can be tolerated during power-up and operation.
3. If T_A is lower, higher P_D values are allowed as long as T_J does not exceed T_J max (see [Table 76: Thermal characteristics on page 122](#)).
4. In low power dissipation state, T_A can be extended to this range as long as T_J does not exceed T_J max (see [Table 76: Thermal characteristics on page 122](#)).

Table 14. Functionalities depending on the operating power supply range

Operating power supply range	Functionalities depending on the operating power supply range				
	DAC and ADC operation	USB	V _{CORE}	Maximum CPU frequency (f _{CPU max})	I/O operation
V _{DD} = 1.65 to 1.8 V	Not functional	Not functional	Range 2 or range 3	16 MHz (1ws) 8MHz (0ws)	Degraded speed performance
V _{DD} = 1.8 to 2.0 V	Conversion time up to 500 Ksps	Not functional	Range 2 or range 3	16 MHz (1ws) 8MHz (0ws)	Degraded speed performance
V _{DD} = 2.0 to 2.4 V	Conversion time up to 500 Ksps	Functional ⁽¹⁾	Range 1, range 2 or range 3	32 MHz (1ws) 16MHz (0ws)	Full speed operation
V _{DD} = 2.4 to 3.6 V	Conversion time up to 1 Msps	Functional ⁽¹⁾	Range 1, range 2 or range 3	32 MHz (1ws) 16MHz (0ws)	Full speed operation

1. To be USB compliant from the IO voltage standpoint, the minimum V_{DD} is 3.0 V.

6.3.2 Embedded reset and power control block characteristics

The parameters given in the following table are derived from the tests performed under the ambient temperature condition summarized in [Table 13](#).

Table 15. Embedded reset and power control block characteristics

Symbol	Parameter	Conditions	Min	Typ	Max	Unit
t _{VDD} ⁽¹⁾	V _{DD} rise time rate	BOR detector enabled	0		∞	μs/V
		BOR detector disabled	0		1000	
	V _{DD} fall time rate	BOR detector enabled	20		∞	
		BOR detector disabled	0		1000	
T _{RSTTEMPO} ⁽¹⁾	Reset temporization	V _{DD} rising, BOR enabled		2	3.3	ms
		V _{DD} rising, BOR disabled	0.4	0.7	1.6	

Table 15. Embedded reset and power control block characteristics (continued)

Symbol	Parameter	Conditions	Min	Typ	Max	Unit
V _{POR/PDR}	Power on/power down reset threshold	Falling edge	1	1.5	1.65	V
		Rising edge	1.3	1.5	1.65	
V _{BOR0}	Brown-out reset threshold 0	Falling edge	1.67	1.7	1.74	
		Rising edge	1.69	1.76	1.8	
V _{BOR1}	Brown-out reset threshold 1	Falling edge	1.87	1.93	1.97	
		Rising edge	1.96	2.03	2.07	
V _{BOR2}	Brown-out reset threshold 2	Falling edge	2.22	2.30	2.35	
		Rising edge	2.31	2.41	2.44	
V _{BOR3}	Brown-out reset threshold 3	Falling edge	2.45	2.55	2.60	
		Rising edge	2.54	2.66	2.7	
V _{BOR4}	Brown-out reset threshold 4	Falling edge	2.68	2.8	2.85	
		Rising edge	2.78	2.9	2.95	
V _{PVD0}	Programmable voltage detector threshold 0	Falling edge	1.8	1.85	1.88	
		Rising edge	1.88	1.94	1.99	
V _{PVD1}	PVD threshold 1	Falling edge	1.98	2.04	2.09	
		Rising edge	2.08	2.14	2.18	
V _{PVD2}	PVD threshold 2	Falling edge	2.20	2.24	2.28	
		Rising edge	2.28	2.34	2.38	
V _{PVD3}	PVD threshold 3	Falling edge	2.39	2.44	2.48	
		Rising edge	2.47	2.54	2.58	
V _{PVD4}	PVD threshold 4	Falling edge	2.57	2.64	2.69	
		Rising edge	2.68	2.74	2.79	
V _{PVD5}	PVD threshold 5	Falling edge	2.77	2.83	2.88	
		Rising edge	2.87	2.94	2.99	
V _{PVD6}	PVD threshold 6	Falling edge	2.97	3.05	3.09	
		Rising edge	3.08	3.15	3.20	
V _{hyst}	Hysteresis voltage	BOR0 threshold	-	40	-	mV
		All BOR and PVD thresholds excepting BOR0	-	100	-	

1. Guaranteed by characterisation, not tested in production.

6.3.3 Embedded internal reference voltage

The parameters given in [Table 16](#) are based on characterization results, unless otherwise specified.

Table 16. Embedded internal reference voltage

Symbol	Parameter	Conditions	Min	Typ	Max	Unit
$V_{REFINT_out}^{(1)}$	Internal reference voltage	$-40\text{ °C} < T_J < +105\text{ °C}$	1.202	1.224	1.242	V
I_{REFINT}	Internal reference current consumption		-	1.4	2.3	μA
$T_{VREFINT}$	Internal reference startup time		-	2	3	ms
V_{VREF_MEAS}	V_{DDA} and V_{REF+} voltage during V_{REFINT} factory measure		2.99	3	3.01	V
A_{VREF_MEAS}	Accuracy of factory-measured V_{REF} value ⁽²⁾	Including uncertainties due to ADC and V_{DDA}/V_{REF+} values	-	-	± 5	mV
$T_{Coeff}^{(3)}$	Temperature coefficient	$-40\text{ °C} < T_J < +105\text{ °C}$	-	20	50	ppm/°C
		$0\text{ °C} < T_J < +50\text{ °C}$	-	-	20	
$A_{Coeff}^{(3)}$	Long-term stability	1000 hours, $T = 25\text{ °C}$	-	-	1000	ppm
$VDDCoeff^{(3)}$	Voltage coefficient	$3.0\text{ V} < V_{DDA} < 3.6\text{ V}$	-	-	2000	ppm/V
$T_{S_vrefint}^{(3)(4)}$	ADC sampling time when reading the internal reference voltage		-	5	10	μs
$T_{ADC_BUF}^{(3)}$	Startup time of reference voltage buffer for ADC		-	-	10	μs
$I_{BUF_ADC}^{(3)}$	Consumption of reference voltage buffer for ADC		-	13.5	25	μA
$I_{VREF_OUT}^{(3)}$	$VREF_OUT$ output current ⁽⁵⁾		-	-	1	μA
$C_{VREF_OUT}^{(3)}$	$VREF_OUT$ output load		-	-	50	pF
$I_{LPBUF}^{(3)}$	Consumption of reference voltage buffer for $VREF_OUT$ and COMP		-	730	1200	nA
$V_{REFINT_DIV1}^{(3)}$	1/4 reference voltage		24	25	26	% V_{REFINT}
$V_{REFINT_DIV2}^{(3)}$	1/2 reference voltage		49	50	51	
$V_{REFINT_DIV3}^{(3)}$	3/4 reference voltage		74	75	76	

1. Tested in production;
2. The internal V_{REF} value is individually measured in production and stored in dedicated EEPROM bytes.
3. Guaranteed by design, not tested in production.
4. Shortest sampling time can be determined in the application by multiple iterations.
5. To guarantee less than 1% $VREF_OUT$ deviation.

6.3.4 Supply current characteristics

The current consumption is a function of several parameters and factors such as the operating voltage, ambient temperature, I/O pin loading, device software configuration, operating frequencies, I/O pin switching rate, program location in memory and executed binary code. The current consumption is measured as described in [Figure 10: Current consumption measurement scheme](#).

All Run-mode current consumption measurements given in this section are performed with a reduced code that gives a consumption equivalent to Dhrystone 2.1 code.

Maximum current consumption

The MCU is placed under the following conditions:

- $V_{DD} = 3.6\text{ V}$
- All I/O pins are in input mode with a static value at V_{DD} or V_{SS} (no load)
- All peripherals are disabled except when explicitly mentioned
- The Flash memory access time is adjusted depending on f_{HCLK} frequency and voltage range
- Prefetch and 64-bit access are enabled in configurations with 1 wait state

The parameters given in [Table 17](#), [Table 13](#) and [Table 15](#) are derived from tests performed under ambient temperature and V_{DD} supply voltage conditions summarized in [Table 13](#).

Table 17. Current consumption in Run mode, code with data processing running from Flash

Symbol	Parameter	Conditions	f_{HCLK}	Typ	Max ⁽¹⁾			Unit		
					55 °C	85 °C	105 °C			
I_{DD} (Run from Flash)	Supply current in Run mode, code executed from Flash	$f_{HSE} = f_{HCLK}$ up to 16 MHz, included $f_{HSE} = f_{HCLK}/2$ above 16 MHz (PLL ON) ⁽²⁾	Range 3, $V_{CORE}=1.2\text{ V}$ $VOS[1:0] = 11$	1 MHz	360	500	500	500	μA	
				2 MHz	620	750	750	750		
				4 MHz	1070	1200	1200	1200		
				Range 2, $V_{CORE}=1.5\text{ V}$ $VOS[1:0] = 10$	4 MHz	1.30	1.6	1.6	1.6	mA
					8 MHz	2.4	2.9	2.9	2.9	
					16 MHz	4.6	5.2	5.2	5.2	
				Range 1, $V_{CORE}=1.8\text{ V}$ $VOS[1:0] = 01$	8 MHz	2.9	3.5	3.5	3.5	
					16 MHz	5.7	6.5	6.5	6.5	
					32 MHz	10.4	12	12	12	
			HSI clock source (16 MHz)	Range 2, $V_{CORE}=1.5\text{ V}$ $VOS[1:0] = 10$	16 MHz	4.5	5.2	5.2	5.2	
				Range 1, $V_{CORE}=1.8\text{ V}$ $VOS[1:0] = 01$	32 MHz	10.9	12.3	12.3	12.3	
			MSI clock, 65 kHz	Range 3, $V_{CORE}=1.2\text{ V}$ $VOS[1:0] = 11$	65 kHz	0.05	0.079	0.092	0.13	
			MSI clock, 524 kHz		524 kHz	0.17	0.2	0.21	0.25	
			MSI clock, 4.2 MHz		4.2 MHz	1.0	1.1	1.1	1.2	

1. Based on characterization, not tested in production, unless otherwise specified.
 2. Oscillator bypassed (HSEBYP = 1 in RCC_CR register).

Table 18. Current consumption in Run mode, code with data processing running from RAM

Symbol	Parameter	Conditions		f _{HCLK}	Typ	Max ⁽¹⁾			Unit
						55 °C	85 °C	105 °C	
I _{DD} (Run from RAM)	Supply current in Run mode, code executed from RAM, Flash switched off	f _{HSE} = f _{HCLK} up to 16 MHz, included f _{HSE} = f _{HCLK} /2 above 16 MHz (PLL ON) ⁽²⁾	Range 3, V _{CORE} =1.2 V VOS[1:0] = 11	1 MHz	310	470	470	470	μA
				2 MHz	590	780	780	780	
				4 MHz	1030	1200	1200	1200 ⁽³⁾	
			Range 2, V _{CORE} =1.5 V VOS[1:0] = 10	4 MHz	1.2	1.5	1.5	1.5	mA
				8 MHz	2.3	3	3	3	
				16 MHz	4.3	5	5	5	
			Range 1, V _{CORE} =1.8 V VOS[1:0] = 01	8 MHz	2.7	3.5	3.5	3.5	
				16 MHz	5.0	5.55	5.55	5.55	
				32 MHz	9.8	10.9	10.9	10.9	
		HSI clock source (16 MHz)	Range 2, V _{CORE} =1.5 V VOS[1:0] = 10	16 MHz	4.3	4.8	4.8	4.8	
				32 MHz	10.1	11.7	11.7	11.7	
		MSI clock, 65 kHz	Range 3, V _{CORE} =1.2 V VOS[1:0] = 11	65 kHz	40	48.5	63	100	μA
		MSI clock, 524 kHz		524 kHz	148	175	183	215	
		MSI clock, 4.2 MHz		4.2 MHz	990	1032	1034	1100	

1. Based on characterization, not tested in production, unless otherwise specified.
2. Oscillator bypassed (HSEBYP = 1 in RCC_CR register).
3. Tested in production.

Table 19. Current consumption in Sleep mode

Symbol	Parameter	Conditions		f _{HCLK}	Typ	Max ⁽¹⁾			Unit
						55 °C	85 °C	105 °C	
I _{DD} (Sleep)	Supply current in Sleep mode, code executed from RAM, Flash switched OFF	f _{HSE} = f _{HCLK} up to 16 MHz, included f _{HSE} = f _{HCLK} /2 above 16 MHz (PLL ON) ⁽²⁾	Range 3, V _{CORE} =1.2 V VOS[1:0] = 11	1 MHz	180	220	220	220	μA
				2 MHz	225	300	300	300	
				4 MHz	300	380	380	380 ⁽³⁾	
			Range 2, V _{CORE} =1.5 V VOS[1:0] = 10	4 MHz	360	500	500	500	
				8 MHz	570	700	700	700	
				16 MHz	990	1100	1100	1100	
			Range 1, V _{CORE} =1.8 V VOS[1:0] = 01	8 MHz	675	800	800	800	
				16 MHz	1150	1250	1250	1250	
				32 MHz	2300	2700	2700	2700	
		HSI clock source (16 MHz)	Range 2, V _{CORE} =1.5 V VOS[1:0] = 10	16 MHz	1025	1100	1100	1100	
				Range 1, V _{CORE} =1.8 V VOS[1:0] = 01	32 MHz	2460	2700	2700	
		MSI clock, 65 kHz	Range 3, V _{CORE} =1.2 V VOS[1:0] = 11	65 kHz	30	36	46	72	
		MSI clock, 524 kHz		524 kHz	50	58	67	92	
		MSI clock, 4.2 MHz		4.2 MHz	210	245	251	273	
		I _{DD} (Sleep)	Supply current in Sleep mode, code executed from Flash	HSE = 16 MHz ⁽²⁾ (PLL ON for f _{HCLK} above 16 MHz)	Range 3, V _{CORE} =1.2 V VOS[1:0] = 11	1 MHz	190	250	
2 MHz	235					300	300	300	
4 MHz	315					380	380	380	
Range 2, V _{CORE} =1.5 V VOS[1:0] = 10	4 MHz				390	500	500	500	
	8 MHz				600	700	700	700	
	16 MHz				1000	1120	1120	1120	
Range 1, V _{CORE} =1.8 V VOS[1:0] = 01	8 MHz				690	800	800	800	
	16 MHz				1160	1300	1300	1300	
	32 MHz				2310	2700	2700	2700	
HSI clock source (16 MHz)	Range 2, V _{CORE} =1.5 V VOS[1:0] = 10			16 MHz	1040	1160	1160	1160	
				Range 1, V _{CORE} =1.8 V VOS[1:0] = 01	32 MHz	2500	2800	2800	2800
I _{DD} (Sleep)	Supply current in Sleep mode, code executed from Flash			MSI clock, 65 kHz	Range 3, V _{CORE} =1.2V VOS[1:0] = 11	65 kHz	42	50	60
		MSI clock, 524 kHz	524 kHz	63		72	82	110	
		MSI clock, 4.2 MHz	4.2 MHz	230		263	265	290	

1. Based on characterization, not tested in production, unless otherwise specified.
2. Oscillator bypassed (HSEBYP = 1 in RCC_CR register)
3. Tested in production.

Table 20. Current consumption in Low power run mode

Symbol	Parameter	Conditions			Typ	Max (1)	Unit
I_{DD} (LP Run)	Supply current in Low power run mode	All peripherals OFF, code executed from RAM, Flash switched OFF, V_{DD} from 1.65 V to 3.6 V	MSI clock, 65 kHz $f_{HCLK} = 32$ kHz	$T_A = -40$ °C to 25 °C	11	14	μA
				$T_A = 85$ °C	26	32	
				$T_A = 105$ °C	53	72	
			MSI clock, 65 kHz $f_{HCLK} = 65$ kHz	$T_A = -40$ °C to 25 °C	18	21	
				$T_A = 85$ °C	33	40	
				$T_A = 105$ °C	60	78	
			MSI clock, 131 kHz $f_{HCLK} = 131$ kHz	$T_A = -40$ °C to 25 °C	36	41	
				$T_A = 55$ °C	39	44	
				$T_A = 85$ °C	50	58	
		All peripherals OFF, code executed from Flash, V_{DD} from 1.65 V to 3.6 V	MSI clock, 65 kHz $f_{HCLK} = 32$ kHz	$T_A = -40$ °C to 25 °C	36	40.5	
				$T_A = 85$ °C	53	60	
				$T_A = 105$ °C	81	100	
			MSI clock, 65 kHz $f_{HCLK} = 65$ kHz	$T_A = -40$ °C to 25 °C	44	49	
				$T_A = 85$ °C	61	67	
				$T_A = 105$ °C	89	107	
			MSI clock, 131 kHz $f_{HCLK} = 131$ kHz	$T_A = -40$ °C to 25 °C	64	71	
				$T_A = 55$ °C	68	73	
				$T_A = 85$ °C	80	88	
			$T_A = 105$ °C	101	110		
I_{DD} max (LP Run)	Max allowed current in Low power run mode	V_{DD} from 1.65 V to 3.6 V			-	200	

1. Based on characterization, not tested in production, unless otherwise specified.

Table 21. Current consumption in Low power sleep mode

Symbol	Parameter	Conditions		Typ	Max (1)	Unit	
I_{DD} (LP Sleep)	Supply current in Low power sleep mode	All peripherals OFF, V_{DD} from 1.65 V to 3.6 V	MSI clock, 65 kHz $f_{HCLK} = 32$ kHz Flash OFF	$T_A = -40$ °C to 25 °C	4.4	-	μA
			MSI clock, 65 kHz $f_{HCLK} = 32$ kHz Flash ON	$T_A = -40$ °C to 25 °C	18	21	
				$T_A = 85$ °C	24	27	
				$T_A = 105$ °C	35	43	
			MSI clock, 65 kHz $f_{HCLK} = 65$ kHz, Flash ON	$T_A = -40$ °C to 25 °C	18.6	21	
				$T_A = 85$ °C	24.5	28	
				$T_A = 105$ °C	35	42	
			MSI clock, 131 kHz $f_{HCLK} = 131$ kHz, Flash ON	$T_A = -40$ °C to 25 °C	22	25	
				$T_A = 55$ °C	23.5	26	
		$T_A = 85$ °C		28.5	31		
		TIM9 and USART1 enabled, Flash ON, V_{DD} from 1.65 V to 3.6 V	MSI clock, 65 kHz $f_{HCLK} = 32$ kHz	$T_A = -40$ °C to 25 °C	18	20.5	
				$T_A = 85$ °C	24	27	
				$T_A = 105$ °C	35	43	
			MSI clock, 65 kHz $f_{HCLK} = 65$ kHz	$T_A = -40$ °C to 25 °C	18.6	21	
				$T_A = 85$ °C	24.5	28	
				$T_A = 105$ °C	35	42	
MSI clock, 131 kHz $f_{HCLK} = 131$ kHz	$T_A = -40$ °C to 25 °C		22	25			
	$T_A = 55$ °C		23.5	26			
	$T_A = 85$ °C		28.5	31			
	$T_A = 105$ °C	39	45				
I_{DD} max (LP Sleep)	Max allowed current in Low power Sleep mode	V_{DD} from 1.65 V to 3.6 V			-	200	

1. Based on characterization, not tested in production, unless otherwise specified.

Table 22. Typical and maximum current consumptions in Stop mode

Symbol	Parameter	Conditions		Typ	Max ⁽¹⁾	Unit	
I _{DD} (Stop with RTC)	Supply current in Stop mode with RTC enabled	RTC clocked by LSI or LSE external clock (32.768kHz), regulator in LP mode, HSI and HSE OFF (no independent watchdog)	LCD OFF	T _A = -40°C to 25°C	1.7	4	μA
				T _A = 55°C	2.7	6	
				T _A = 85°C	7	10	
				T _A = 105°C	15	23	
			LCD ON (static duty) ⁽²⁾	T _A = -40°C to 25°C	3.8	6	
				T _A = 55°C	4.7	7	
				T _A = 85°C	9	12	
				T _A = 105°C	19	27	
			LCD ON (1/8 duty) ⁽³⁾	T _A = -40°C to 25°C	7.8	10	
				T _A = 55°C	8.5	11	
				T _A = 85°C	13	16	
				T _A = 105°C	26	44	
		RTC clocked by LSE external quartz (32.768kHz), regulator in LP mode, HSI and HSE OFF (no independent watchdog) ⁽⁴⁾	LCD OFF	T _A = -40°C to 25°C	2.1	-	
				T _A = 55°C	3.1	-	
				T _A = 85°C	7.5	-	
				T _A = 105°C	15	-	
LCD ON (static duty) ⁽²⁾	T _A = -40°C to 25°C		4.2	-			
	T _A = 55°C		5.1	-			
	T _A = 85°C		9.5	-			
LCD ON (1/8 duty) ⁽³⁾	T _A = -40°C to 25°C		8.2	-			
	T _A = 55°C		8.9	-			
	T _A = 85°C		13.5	-			
LCD OFF	T _A = -40°C to 25°C V _{DD} = 1.8V		TBD	-			
	T _A = -40°C to 25°C V _{DD} = 3.0V		TBD	-			
	T _A = -40°C to 25°C V _{DD} = 3.6V	2.1	-				
I _{DD} (Stop)	Supply current in Stop mode (RTC disabled)	Regulator in LP mode, HSI and HSE OFF, independent watchdog and LSI enabled	T _A = -40°C to 25°C	1.6	2.2	μA	
		Regulator in LP mode, LSI, HSI and HSE OFF (no independent watchdog)	T _A = -40°C to 25°C	0.65	1		
			T _A = 55°C	1.6	3		
			T _A = 85°C	6	9		
			T _A = 105°C	14	22 ⁽⁵⁾		

Table 22. Typical and maximum current consumptions in Stop mode (continued)

Symbol	Parameter	Conditions	Typ	Max ⁽¹⁾	Unit	
I _{DD} (WU from Stop)	Supply current during wakeup from Stop mode	MSI = 4.2 MHz	T _A = -40°C to 25°C	2	-	mA
		MSI = 1.05 MHz		1.45	-	
		MSI = 65 kHz ⁽⁶⁾		1.45	-	

1. Based on characterization, not tested in production, unless otherwise specified.
2. LCD enabled with external VLCD, static duty, division ratio = 256, all pixels active, no LCD connected.
3. LCD enabled with external VLCD, 1/4 duty, 1/3 bias, division ratio = 64, all pixels active, no LCD connected.
4. Based on characterization done with a 32.768 kHz crystal (MC306-G-06Q-32.768, manufacturer JFVNY) with two 6.8 pF loading capacitors.
5. Tested in production.
6. When MSI = 64 kHz, the RMS current is measured over the first 15 μs following the wakeup event. For the remaining part of the wakeup period, the current corresponds the Run mode current.

Table 23. Typical and maximum current consumptions in Standby mode

Symbol	Parameter	Conditions	Typ	Max ⁽¹⁾	Unit	
I _{DD} (Standby with RTC)	Supply current in Standby mode with RTC enabled	RTC clocked by LSI (no independent watchdog)	T _A = -40 °C to 25 °C	1.3	1.9	μA
			T _A = 55 °C	1.5	2.2	
			T _A = 85 °C	2.15	4	
			T _A = 105 °C	3.8	8.3 ⁽²⁾	
		RTC clocked by LSE external quartz (no independent watchdog) ⁽³⁾	T _A = -40 °C to 25 °C	1.7	-	
			T _A = 55 °C	1.9	-	
			T _A = 85 °C	2.6	-	
			T _A = 105 °C	4.4	-	
I _{DD} (Standby)	Supply current in Standby mode (RTC disabled)	Independent watchdog and LSI enabled	T _A = -40 °C to 25 °C	1.3	1.7	
			Independent watchdog and LSI OFF	T _A = -40 °C to 25 °C	0.35	0.6
		T _A = 55 °C		0.47	0.9	
		T _A = 85 °C	1.2	2.75		
T _A = 105 °C	2.9	7 ⁽²⁾				
I _{DD} (WU from Standby)	Supply current during wakeup from Standby mode	T _A = -40 °C to 25 °C	1	-		

1. Based on characterization, not tested in production, unless otherwise specified
2. Tested in production.
3. Based on characterization done with a 32.768 kHz crystal (MC306-G-06Q-32.768, manufacturer JFVNY) with two 6.8pF loading capacitors.

Wakeup time from low-power mode

The wakeup times given in the following table are measured with the MSI RC oscillator. The clock source used to wake up the device depends on the current operating mode:

- Sleep mode: the clock source is the clock that was set before entering Sleep mode
- Stop mode: the clock source is the MSI oscillator in the range configured before entering Stop mode
- Standby mode: the clock source is the MSI oscillator running at 2.1 MHz

All timings are derived from tests performed under ambient temperature and V_{DD} supply voltage conditions summarized in [Table 13](#).

Table 24. Typical and maximum timings in Low power modes

Symbol	Parameter	Conditions	Typ	Max ⁽¹⁾	Unit
t _{WUSLEEP}	Wakeup from Sleep mode	f _{HCLK} = 32 MHz	0.4	-	μs
t _{WUSLEEP_LP}	Wakeup from Low power sleep mode f _{HCLK} = 262 kHz	f _{HCLK} = 262 kHz Flash enabled	46	-	
		f _{HCLK} = 262 kHz Flash switched OFF	46	-	
t _{WUSTOP}	Wakeup from Stop mode, regulator in Run mode	f _{HCLK} = f _{MSI} = 4.2 MHz	8.2	-	
		f _{HCLK} = f _{MSI} = 4.2 MHz Voltage range 1 and 2	7.7	8.9	
	Wakeup from Stop mode, regulator in low power mode	f _{HCLK} = f _{MSI} = 4.2 MHz Voltage range 3	8.2	13.1	
		f _{HCLK} = f _{MSI} = 2.1 MHz	10.2	13.4	
		f _{HCLK} = f _{MSI} = 1.05 MHz	16	20	
		f _{HCLK} = f _{MSI} = 524 kHz	31	37	
		f _{HCLK} = f _{MSI} = 262 kHz	57	66	
		f _{HCLK} = f _{MSI} = 131 kHz	112	123	
f _{HCLK} = MSI = 65 kHz	221	236			
t _{WUSTDBY}	Wakeup from Standby mode FWU bit = 1	f _{HCLK} = MSI = 2.1 MHz	58	104	
	Wakeup from Standby mode FWU bit = 0	f _{HCLK} = MSI = 2.1 MHz	2.6	3.25	

1. Based on characterization, not tested in production, unless otherwise specified

On-chip peripheral current consumption

The current consumption of the on-chip peripherals is given in the following table. The MCU is placed under the following conditions:

- all I/O pins are in input mode with a static value at V_{DD} or V_{SS} (no load)
- all peripherals are disabled unless otherwise mentioned
- the given value is calculated by measuring the current consumption
 - with all peripherals clocked off
 - with only one peripheral clocked on

Table 25. Peripheral current consumption⁽¹⁾

Peripheral		Typical consumption, $V_{DD} = 3.0\text{ V}$, $T_A = 25\text{ °C}$				Unit
		Range 1, $V_{CORE} = 1.8\text{ V}$ $VOS[1:0] = 01$	Range 2, $V_{CORE} = 1.5\text{ V}$ $VOS[1:0] = 10$	Range 3, $V_{CORE} = 1.2\text{ V}$ $VOS[1:0] = 11$	Low power sleep and run	
APB1	TIM2	13	11	9	11	$\mu\text{A}/\text{MHz}$ (f_{HCLK})
	TIM3	12	10	9	11	
	TIM4	12	10	9	11	
	TIM5	16	13	11	14	
	TIM6	4	4	4	4	
	TIM7	4	4	4	4	
	LCD	4	3	3	4	
	WWDG	3	2.5	2.5	3	
	SPI2	8	7	9	7.5	
	SPI3	7	6	7	6	
	USART2	8	7	7	7	
	USART3	8	7	7	7	
	USART4	8	7	7	7	
	USART5	8	7	7	7	
	I2C1	8	7	6	7	
	I2C2	7	6	5	6	
	USB	15	7	7	7	
	PWR	3	3	3	3	
	DAC	6	5	4.5	5	
COMP	4	3.5	3.5	4		

Table 25. Peripheral current consumption⁽¹⁾ (continued)

Peripheral		Typical consumption, V _{DD} = 3.0 V, T _A = 25 °C				Unit
		Range 1, V _{CORE} = 1.8 V VOS[1:0] = 01	Range 2, V _{CORE} = 1.5 V VOS[1:0] = 10	Range 3, V _{CORE} = 1.2 V VOS[1:0] = 11	Low power sleep and run	
APB2	SYSCFG & RI	3	2	2	3	μA/MHz (f _{HCLK})
	TIM9	8	7	6	7	
	TIM10	6	5	5	5	
	TIM11	6	5	5	5	
	ADC ⁽²⁾	10	8	7	8	
	SDIO	20	6	5	6	
	SPI1	4	4	4	4	
	USART1	8	7	6	7	
AHB	GPIOA	7	6	5	6	
	GPIOB	7	6	5	6	
	GPIOC	7	6	5	6	
	GPIOD	7	6	5	6	
	GPIOE	7	6	5	6	
	GPIOF	7	6	5	6	
	GPIOG	7	6	5	6	
	GPIOH	2	2	1	2	
	CRC	0.5	0.5	0.5	1	
	FLASH	26	26	29	.(3)	
	DMA1	18	15	13	18	
DMA2	16	14	12	16		
FSMC	15	12	10	12		
All enabled		279	221	219	215	

Table 25. Peripheral current consumption⁽¹⁾ (continued)

Peripheral	Typical consumption, V _{DD} = 3.0 V, T _A = 25 °C				Unit
	Range 1, V _{CORE} = 1.8 V VOS[1:0] = 01	Range 2, V _{CORE} = 1.5 V VOS[1:0] = 10	Range 3, V _{CORE} = 1.2 V VOS[1:0] = 11	Low power sleep and run	
I _{DD} (RTC)	0.4				μA
I _{DD} (LCD)	3.1				
I _{DD} (ADC) ⁽⁴⁾	1450				
I _{DD} (DAC) ⁽⁵⁾	340				
I _{DD} (COMP1)	0.16				
I _{DD} (COMP2)	Slow mode	2			
	Fast mode	5			
I _{DD} (PVD / BOR) ⁽⁶⁾	2.6				
I _{DD} (IWDG)	0.25				

1. Data based on differential I_{DD} measurement between all peripherals OFF or one peripheral with clock enabled, in the following conditions: f_{HCLK} = 32 MHz (range 1), f_{HCLK} = 16 MHz (range 2), f_{HCLK} = 4 MHz (range 3), f_{HCLK} = 64kHz (Low power run/sleep), f_{APB1} = f_{HCLK}, f_{APB2} = f_{HCLK}; default prescaler value for each peripheral. The CPU is in Sleep mode in both cases. No I/O pins toggling. Not tested in production.
2. HSI oscillator is OFF for this measure.
3. In low power sleep and run mode, the Flash memory must always be in power-down mode.
4. Data based on a differential I_{DD} measurement between ADC in reset configuration and continuous ADC conversion (HSI consumption not included).
5. Data based on a differential I_{DD} measurement between DAC in reset configuration and continuous DAC conversion of V_{DD}/2. DAC is in buffered mode, output is left floating.
6. Including supply current of internal reference voltage.

6.3.5 External clock source characteristics

High-speed external user clock generated from an external source

Table 26. High-speed external user clock characteristics⁽¹⁾

Symbol	Parameter	Conditions	Min	Typ	Max	Unit
f _{HSE_ext}	User external clock source frequency		1	8	32	MHz
V _{HSEH}	OSC_IN input pin high level voltage		0.7V _{DD}	-	V _{DD}	V
V _{HSEL}	OSC_IN input pin low level voltage		V _{SS}	-	0.3V _{DD}	
t _{w(HSE)} t _{w(HSE)}	OSC_IN high or low time		12	-	-	ns
t _{r(HSE)} t _{f(HSE)}	OSC_IN rise or fall time		-	-	20	
C _{in(HSE)}	OSC_IN input capacitance		-	2.6	-	pF

Table 26. High-speed external user clock characteristics⁽¹⁾

Symbol	Parameter	Conditions	Min	Typ	Max	Unit
DuCy _(HSE)	Duty cycle		45	-	55	%
I _L	OSC_IN Input leakage current	$V_{SS} \leq V_{IN} \leq V_D$	-	-	±1	μA

1. Guaranteed by design, not tested in production.

Low-speed external user clock generated from an external source

The characteristics given in the following table result from tests performed using a low-speed external clock source, and under ambient temperature and supply voltage conditions summarized in [Table 13](#).

Table 27. Low-speed external user clock characteristics⁽¹⁾

Symbol	Parameter	Conditions	Min	Typ	Max	Unit
f_{LSE_ext}	User external clock source frequency		1	32.768	1000	kHz
V_{LSEH}	OSC32_IN input pin high level voltage		$0.7V_{DD}$	-	V_{DD}	V
V_{LSEL}	OSC32_IN input pin low level voltage		V_{SS}	-	$0.3V_{DD}$	
$t_{w(LSE)}$ $t_{w(LSE)}$	OSC32_IN high or low time		TBD	-	-	ns
$t_{r(LSE)}$ $t_{f(LSE)}$	OSC32_IN rise or fall time		-	-	TBD	
$C_{IN(LSE)}$	OSC32_IN input capacitance		-	0.6	-	pF
$DuCy_{(LSE)}$	Duty cycle		TBD	-	TBD	%
I_L	OSC32_IN Input leakage current	$V_{SS} \leq V_{IN} \leq V_{DD}$	-	-	± 1	μA

1. Guaranteed by design, not tested in production

Figure 11. Low-speed external clock source AC timing diagram

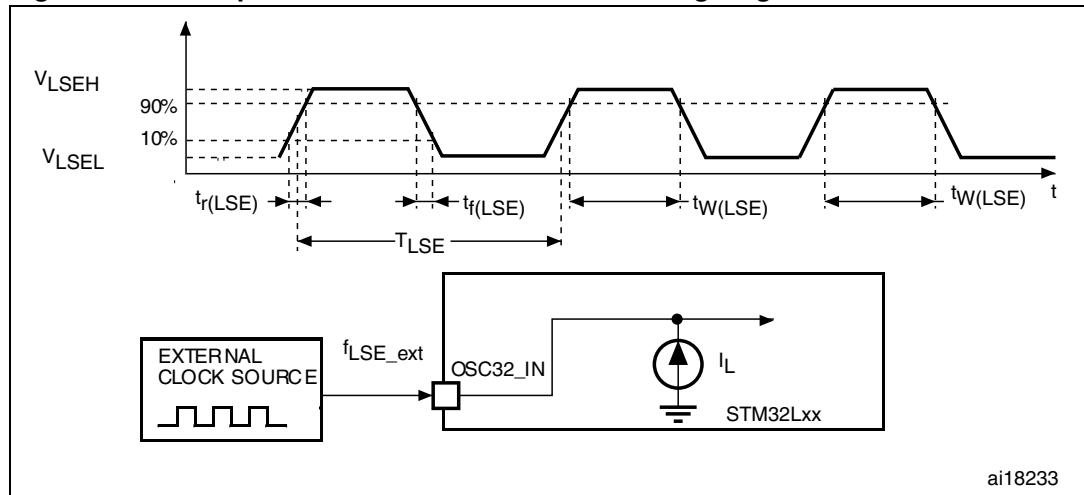
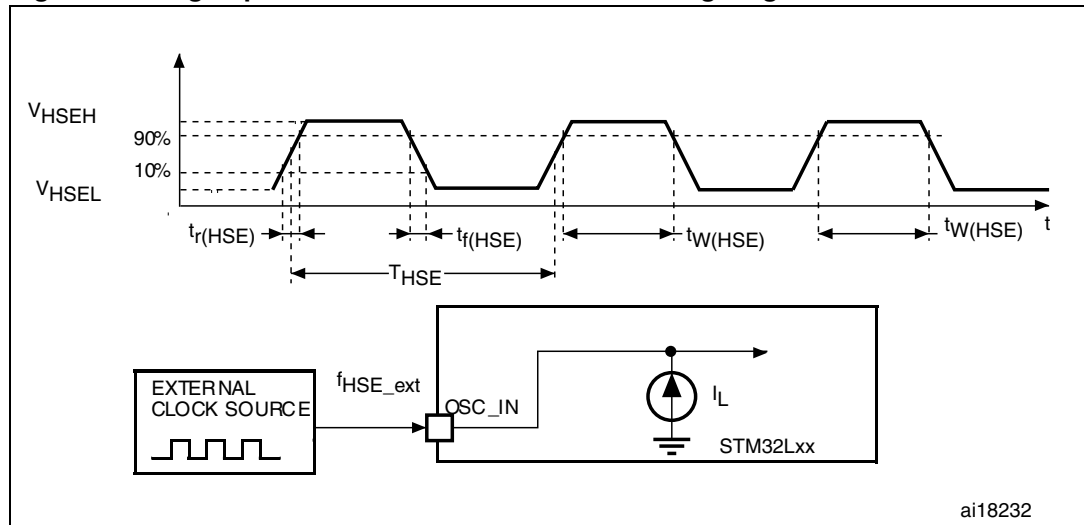

Figure 12. High-speed external clock source AC timing diagram



High-speed external clock generated from a crystal/ceramic resonator

The high-speed external (HSE) clock can be supplied with a 1 to 24 MHz crystal/ceramic resonator oscillator. All the information given in this paragraph are based on characterization results obtained with typical external components specified in [Table 28](#). In the application, the resonator and the load capacitors have to be placed as close as possible to the oscillator pins in order to minimize output distortion and startup stabilization time. Refer to the crystal resonator manufacturer for more details on the resonator characteristics (frequency, package, accuracy).

Table 28. HSE 1-24 MHz oscillator characteristics⁽¹⁾⁽²⁾

Symbol	Parameter	Conditions	Min	Typ	Max	Unit
f_{OSC_IN}	Oscillator frequency		1		24	MHz
R_F	Feedback resistor		-	200	-	k Ω
C	Recommended load capacitance versus equivalent serial resistance of the crystal (R_S) ⁽³⁾	$R_S = 30 \Omega$	-	20	-	pF
I_{HSE}	HSE driving current	$V_{DD} = 3.3 V$, $V_{IN} = V_{SS}$ with 30 pF load	-	-	3	mA
$I_{DD(HSE)}$	HSE oscillator power consumption	C = 20 pF $f_{OSC} = 16$ MHz	-	-	2.5 (startup) 0.7 (stabilized)	mA
		C = 10 pF $f_{OSC} = 16$ MHz	-	-	2.5 (startup) 0.46 (stabilized)	
g_m	Oscillator transconductance	Startup	3.5	-	-	mA /V
$t_{SU(HSE)}$ (4)	Startup time	V_{DD} is stabilized	-	1	-	ms

1. Resonator characteristics given by the crystal/ceramic resonator manufacturer.
2. Based on characterization results, not tested in production.
3. The relatively low value of the RF resistor offers a good protection against issues resulting from use in a humid environment, due to the induced leakage and the bias condition change. However, it is recommended to take this point into account if the MCU is used in tough humidity conditions.
4. $t_{SU(HSE)}$ is the startup time measured from the moment it is enabled (by software) to a stabilized 8 MHz oscillation is reached. This value is measured for a standard crystal resonator and it can vary significantly with the crystal manufacturer.

For C_{L1} and C_{L2} , it is recommended to use high-quality external ceramic capacitors in the 5 pF to 25 pF range (typ.), designed for high-frequency applications, and selected to match the requirements of the crystal or resonator (see [Figure 13](#)). C_{L1} and C_{L2} are usually the same size. The crystal manufacturer typically specifies a load capacitance which is the series combination of C_{L1} and C_{L2} . PCB and MCU pin capacitance must be included (10 pF can be used as a rough estimate of the combined pin and board capacitance) when sizing C_{L1} and C_{L2} . Refer to the application note AN2867 "Oscillator design guide for ST microcontrollers" available from the ST website www.st.com.

Figure 13. HSE oscillator circuit diagram

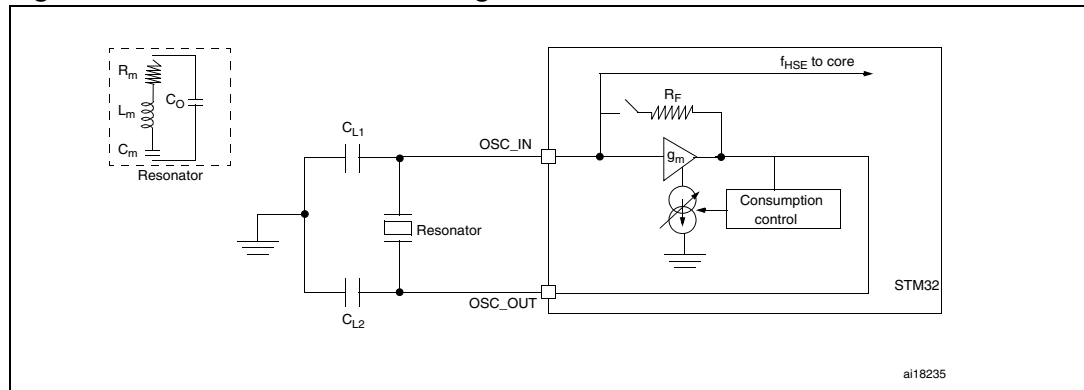

1. R_{EXT} value depends on the crystal characteristics.

Low-speed external clock generated from a crystal/ceramic resonator

The low-speed external (LSE) clock can be supplied with a 32.768 kHz crystal/ceramic resonator oscillator. All the information given in this paragraph are based on characterization results obtained with typical external components specified in [Table 29](#). In the application, the resonator and the load capacitors have to be placed as close as possible to the oscillator pins in order to minimize output distortion and startup stabilization time. Refer to the crystal resonator manufacturer for more details on the resonator characteristics (frequency, package, accuracy).

Table 29. LSE oscillator characteristics ($f_{LSE} = 32.768 \text{ kHz}$)⁽¹⁾

Symbol	Parameter	Conditions	Min	Typ	Max	Unit
f_{LSE}	Low speed external oscillator frequency		-	32.768	-	kHz
R_F	Feedback resistor		-	1.2	-	MΩ
$C^{(2)}$	Recommended load capacitance versus equivalent serial resistance of the crystal (R_S) ⁽³⁾	$R_S = 30 \text{ k}\Omega$	-	8	-	pF
I_{LSE}	LSE driving current	$V_{DD} = 3.3 \text{ V}, V_{IN} = V_{SS}$	-	-	1.1	μA
$I_{DD} \text{ (LSE)}$	LSE oscillator current consumption	$V_{DD} = 1.8 \text{ V}$	-	450	-	nA
		$V_{DD} = 3.0 \text{ V}$	-	600	-	
		$V_{DD} = 3.6 \text{ V}$	-	750	-	
g_m	Oscillator transconductance		3		-	μA/V
$t_{SU(LSE)}^{(4)}$	Startup time	V_{DD} is stabilized	-	1	-	s

1. Based on characterization, not tested in production.
2. Refer to the note and caution paragraphs below the table, and to the application note AN2867 "Oscillator design guide for ST microcontrollers".
3. The oscillator selection can be optimized in terms of supply current using a high quality resonator with small R_S value for example MSIV-TIN32.768kHz. Refer to crystal manufacturer for more details;
4. $t_{SU(LSE)}$ is the startup time measured from the moment it is enabled (by software) to a stabilized 32.768 kHz oscillation is reached. This value is measured for a standard crystal resonator and it can vary significantly with the crystal manufacturer.

Note: For C_{L1} and C_{L2} , it is recommended to use high-quality ceramic capacitors in the 5 pF to 15 pF range selected to match the requirements of the crystal or resonator (see [Figure 14](#)). C_{L1} and C_{L2} are usually the same size. The crystal manufacturer typically specifies a load capacitance which is the series combination of C_{L1} and C_{L2} . Load capacitance C_L has the following formula: $C_L = C_{L1} \times C_{L2} / (C_{L1} + C_{L2}) + C_{stray}$ where C_{stray} is the pin capacitance and board or trace PCB-related capacitance. Typically, it is between 2 pF and 7 pF.

Caution: To avoid exceeding the maximum value of C_{L1} and C_{L2} (15 pF) it is strongly recommended to use a resonator with a load capacitance $C_L \leq 7$ pF. Never use a resonator with a load capacitance of 12.5 pF.

Example: if you choose a resonator with a load capacitance of $C_L = 6$ pF and $C_{stray} = 2$ pF, then $C_{L1} = C_{L2} = 8$ pF.

Figure 14. Typical application with a 32.768 kHz crystal

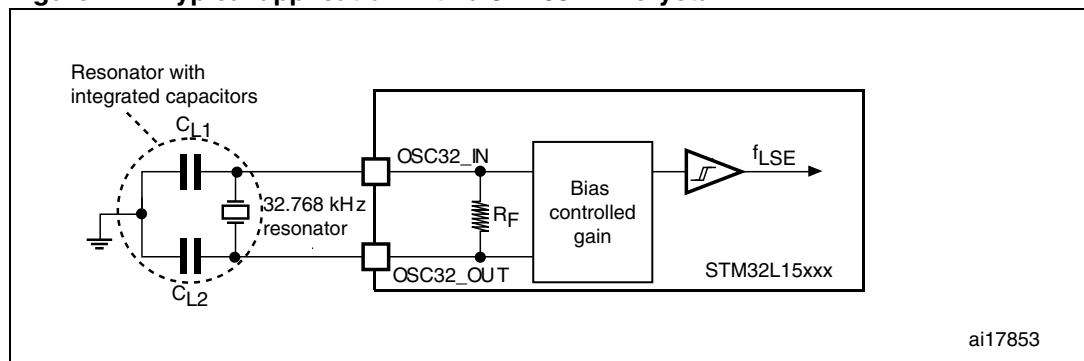

ai17853

6.3.6 Internal clock source characteristics

The parameters given in [Table 30](#) are derived from tests performed under ambient temperature and V_{DD} supply voltage conditions summarized in [Table 13](#).

High-speed internal (HSI) RC oscillator

Table 30. HSI oscillator characteristics

Symbol	Parameter	Conditions	Min	Typ	Max	Unit
f_{HSI}	Frequency	$V_{DD} = 3.0\text{ V}$	-	16	-	MHz
$TRIM^{(1)(2)}$	HSI user-trimmed resolution	Trimming code is not a multiple of 16	-	± 0.4	0.7	%
		Trimming code is a multiple of 16	-	-	± 1.5	%
$ACC_{HSI}^{(2)}$	Accuracy of the factory-calibrated HSI oscillator	$V_{DDA} = 3.0\text{ V}, T_A = 25\text{ }^\circ\text{C}$	-1 ⁽³⁾	-	1 ⁽³⁾	%
		$V_{DDA} = 3.0\text{ V}, T_A = 0\text{ to }55\text{ }^\circ\text{C}$	-1.5	-	1.5	%
		$V_{DDA} = 3.0\text{ V}, T_A = -10\text{ to }70\text{ }^\circ\text{C}$	-2	-	2	%
		$V_{DDA} = 3.0\text{ V}, T_A = -10\text{ to }85\text{ }^\circ\text{C}$	-2.5	-	2	%
		$V_{DDA} = 3.0\text{ V}, T_A = -10\text{ to }105\text{ }^\circ\text{C}$	-4	-	2	%
		$V_{DDA} = 1.65\text{ V to }3.6\text{ V}$ $T_A = -40\text{ to }105\text{ }^\circ\text{C}$	-4	-	3	%
$t_{SU(HSI)}^{(2)}$	HSI oscillator startup time		-	3.7	6	μs
$I_{DD(HSI)}^{(2)}$	HSI oscillator power consumption		-	100	140	μA

1. The trimming step differs depending on the trimming code. It is usually negative on the codes which are multiples of 16 (0x00, 0x10, 0x20, 0x30...0xE0).
2. Based on characterization, not tested in production.
3. Tested in production.

Low-speed internal (LSI) RC oscillator

Table 31. LSI oscillator characteristics

Symbol	Parameter	Min	Typ	Max	Unit
$f_{LSI}^{(1)}$	LSI frequency	26	38	56	kHz
$D_{LSI}^{(2)}$	LSI oscillator frequency drift $0^\circ\text{C} \leq T_A \leq 85^\circ\text{C}$	-10	-	4	%
$t_{SU(LSI)}^{(3)}$	LSI oscillator startup time	-	-	200	μs
$I_{DD(LSI)}^{(3)}$	LSI oscillator power consumption	-	400	510	nA

1. Tested in production.
2. This is a deviation for an individual part, once the initial frequency has been measured.
3. Guaranteed by design, not tested in production.

Multi-speed internal (MSI) RC oscillator

Table 32. MSI oscillator characteristics

Symbol	Parameter	Condition	Typ	Max	Unit
f_{MSI}	Frequency after factory calibration, done at $V_{\text{DD}} = 3.3 \text{ V}$ and $T_{\text{A}} = 25 \text{ }^{\circ}\text{C}$	MSI range 0	65.5	-	kHz
		MSI range 1	131	-	
		MSI range 2	262	-	
		MSI range 3	524	-	MHz
		MSI range 4	1.05	-	
		MSI range 5	2.1	-	
		MSI range 6	4.2	-	
ACC_{MSI}	Frequency error after factory calibration		± 0.5	-	%
$D_{\text{TEMP}(\text{MSI})}^{(1)}$	MSI oscillator frequency drift $0 \text{ }^{\circ}\text{C} \leq T_{\text{A}} \leq 85 \text{ }^{\circ}\text{C}$		± 3	-	%
$D_{\text{VOLT}(\text{MSI})}^{(1)}$	MSI oscillator frequency drift $1.65 \text{ V} \leq V_{\text{DD}} \leq 3.6 \text{ V}$, $T_{\text{A}} = 25 \text{ }^{\circ}\text{C}$		-	2.5	%/V
$I_{\text{DD}(\text{MSI})}^{(2)}$	MSI oscillator power consumption	MSI range 0	0.75	-	μA
		MSI range 1	1	-	
		MSI range 2	1.5	-	
		MSI range 3	2.5	-	
		MSI range 4	4.5	-	
		MSI range 5	8	-	
		MSI range 6	15	-	

Table 32. MSI oscillator characteristics (continued)

Symbol	Parameter	Condition	Typ	Max	Unit
$t_{SU(MSI)}$	MSI oscillator startup time	MSI range 0	30	-	μs
		MSI range 1	20	-	
		MSI range 2	15	-	
		MSI range 3	10	-	
		MSI range 4	6	-	
		MSI range 5	5	-	
		MSI range 6, Voltage range 1 and 2	3.5	-	
		MSI range 6, Voltage range 3	5	-	
$t_{STAB(MSI)}^{(2)}$	MSI oscillator stabilization time	MSI range 0	-	40	μs
		MSI range 1	-	20	
		MSI range 2	-	10	
		MSI range 3	-	4	
		MSI range 4	-	2.5	
		MSI range 5	-	2	
		MSI range 6, Voltage range 1 and 2	-	2	
		MSI range 3, Voltage range 3	-	3	
$f_{OVER(MSI)}$	MSI oscillator frequency overshoot	Any range to range 5	-	4	MHz
		Any range to range 6	-	6	

1. This is a deviation for an individual part, once the initial frequency has been measured.
2. Based on characterization, not tested in production.

6.3.7 PLL characteristics

The parameters given in [Table 33](#) are derived from tests performed under ambient temperature and V_{DD} supply voltage conditions summarized in [Table 13](#).

Table 33. PLL characteristics

Symbol	Parameter	Value			Unit
		Min	Typ	Max ⁽¹⁾	
f _{PLL_IN}	PLL input clock ⁽²⁾	2	-	24	MHz
	PLL input clock duty cycle	45	-	55	%
f _{PLL_OUT}	PLL output clock	2	-	32	MHz
t _{LOCK}	Worst case PLL lock time PLL input = 2 MHz PLL VCO = 96 MHz	-	100	130	μs
Jitter	Cycle-to-cycle jitter	-		± 600	ps
I _{DDA(PLL)}	Current consumption on V _{DDA}	-	220	450	μA
I _{DD(PLL)}	Current consumption on V _{DD}	-	120	150	

1. Based on characterization, not tested in production.
2. Take care of using the appropriate multiplier factors so as to have PLL input clock values compatible with the range defined by f_{PLL_OUT}.

6.3.8 Memory characteristics

The characteristics are given at T_A = -40 to 105 °C unless otherwise specified.

RAM memory

Table 34. RAM and hardware registers

Symbol	Parameter	Conditions	Min	Typ	Max	Unit
VRM	Data retention mode ⁽¹⁾	STOP mode (or RESET)	1.65	-	-	V

1. Minimum supply voltage without losing data stored in RAM (in Stop mode or under Reset) or in hardware registers (only in Stop mode).

Flash memory and data EEPROM

Table 35. Flash memory and data EEPROM characteristics

Symbol	Parameter	Conditions	Min	Typ	Max ⁽¹⁾	Unit
V_{DD}	Operating voltage Read / Write / Erase		1.65	-	3.6	V
t_{prog}	Programming time for word or half-page	Erasing	-	3.28	3.94	ms
		Programming	-	3.28	3.94	
I_{DD}	Average current during the whole programming / erase operation	$T_A = 25\text{ °C}$, $V_{DD} = 3.6\text{ V}$	-	600	900	μA
	Maximum current (peak) during the whole pro- gramming / erase opera- tion		-	1.5	2.5	mA

1. Guaranteed by design, not tested in production.

Table 36. Flash memory and data EEPROM endurance and retention

Symbol	Parameter	Conditions	Value			Unit
			Min ⁽¹⁾	Typ	Max	
$N_{CYC}^{(2)}$	Cycling (erase / write) Program memory	$T_A = -40\text{ °C}$ to 105 °C	10	-	-	kcycles
	Cycling (erase / write) EEPROM data memory		300	-	-	
$t_{RET}^{(2)}$	Data retention (program memory) after 10 kcycles at $T_A = 85\text{ °C}$	$T_{RET} = +85\text{ °C}$	30	-	-	years
	Data retention (EEPROM data memory) after 300 kcycles at $T_A = 85\text{ °C}$		30	-	-	
	Data retention (program memory) after 10 kcycles at $T_A = 105\text{ °C}$	$T_{RET} = +105\text{ °C}$	10	-	-	
	Data retention (EEPROM data memory) after 300 kcycles at $T_A = 105\text{ °C}$		10	-	-	

1. Based on characterization not tested in production.

2. Characterization is done according to JEDEC JESD22-A117.

6.3.9 FSMC characteristics

Asynchronous waveforms and timings

Figure 15 through Figure 18 represent asynchronous waveforms and Table 37 through Table 40 provide the corresponding timings. The results shown in these tables are obtained with the following FSMC configuration:

- AddressSetupTime = 0
- AddressHoldTime = 1
- DataSetupTime = 1

Figure 15. Asynchronous non-multiplexed SRAM/PSRAM/NOR read waveforms

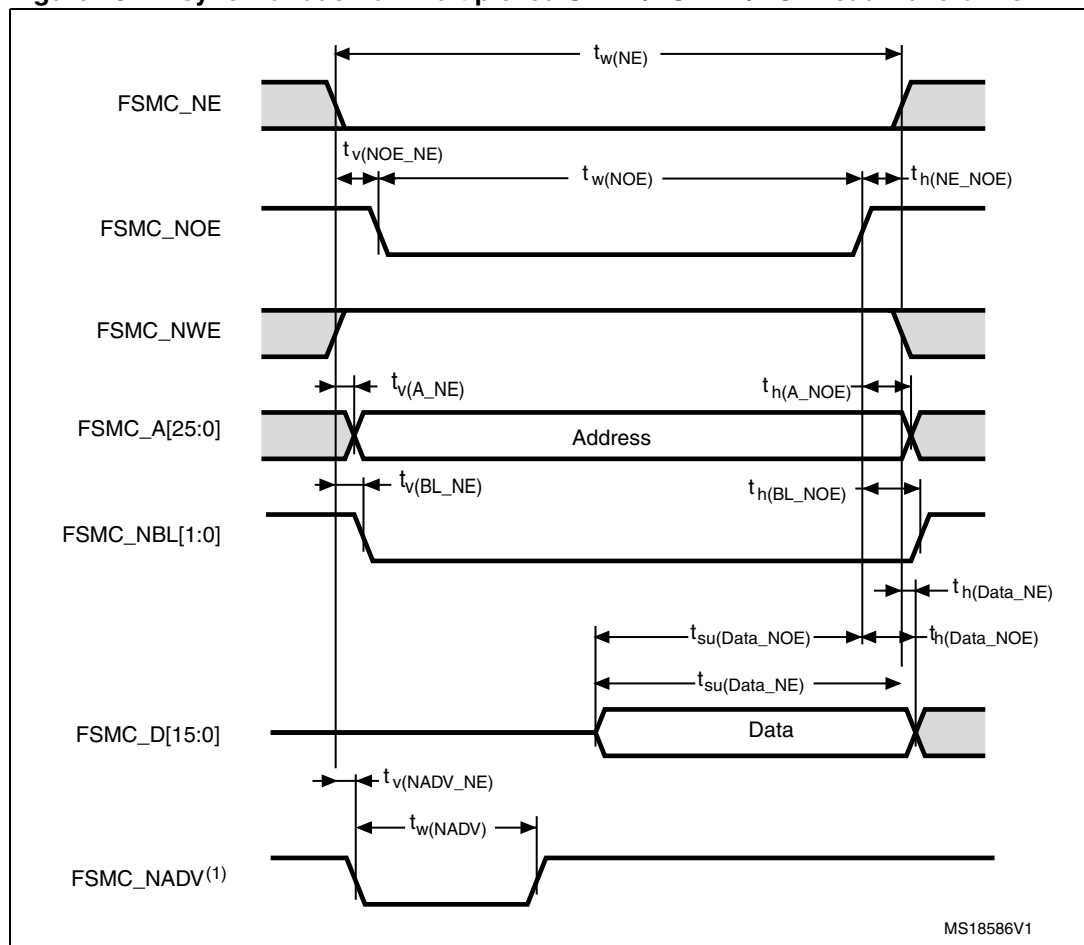

1. Mode 2/B, C and D only. In Mode 1, FSMC_NADV is not used.

Table 37. Asynchronous non-multiplexed SRAM/PSRAM/NOR read timings⁽¹⁾⁽²⁾

Symbol	Parameter	Min	Max	Unit
$t_{w(NE)}$	FSMC_NE low time	TBD	TBD	ns
$t_{v(NOE_NE)}$	FSMC_NEx low to FSMC_NOE low	TBD	TBD	ns
$t_{w(NOE)}$	FSMC_NOE low time	TBD	TBD	ns
$t_{h(NE_NOE)}$	FSMC_NOE high to FSMC_NE high hold time	TBD	-	ns
$t_{v(A_NE)}$	FSMC_NEx low to FSMC_A valid	-	0	ns
$t_{h(A_NOE)}$	Address hold time after FSMC_NOE high	TBD	-	ns
$t_{v(BL_NE)}$	FSMC_NEx low to FSMC_BL valid	-	0	ns
$t_{h(BL_NOE)}$	FSMC_BL hold time after FSMC_NOE high	0	-	ns
$t_{su(Data_NE)}$	Data to FSMC_NEx high setup time	TBD	-	ns
$t_{su(Data_NOE)}$	Data to FSMC_NOEx high setup time	TBD	-	ns
$t_{h(Data_NOE)}$	Data hold time after FSMC_NOE high	0	-	ns
$t_{h(Data_NE)}$	Data hold time after FSMC_NEx high	0	-	ns
$t_{v(NADV_NE)}$	FSMC_NEx low to FSMC_NADV low	-	5	ns
$t_{w(NADV)}$	FSMC_NADV low time	-	TBD	ns

1. $C_L = 15$ pF.
2. Preliminary values.

Figure 16. Asynchronous non-multiplexed SRAM/PSRAM/NOR write waveforms

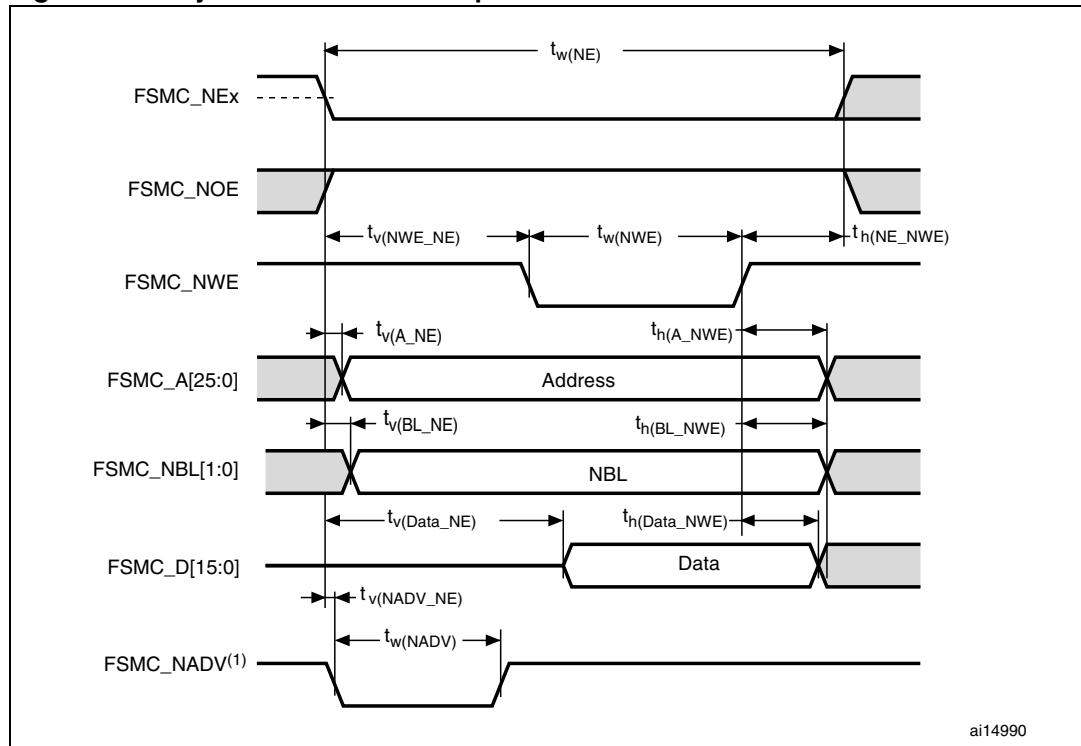

1. Mode 2/B, C and D only. In Mode 1, FSMC_NADV is not used.

Table 38. Asynchronous non-multiplexed SRAM/PSRAM/NOR write timings⁽¹⁾⁽²⁾

Symbol	Parameter	Min	Max	Unit
$t_{w(NE)}$	FSMC_NE low time	TBD	TBD	ns
$t_{v(NWE_NE)}$	FSMC_NEx low to FSMC_NWE low	TBD	TBD	ns
$t_{w(NWE)}$	FSMC_NWE low time	TBD	TBD	ns
$t_{h(NE_NWE)}$	FSMC_NWE high to FSMC_NE high hold time	T_{HCLK}	-	ns
$t_{v(A_NE)}$	FSMC_NEx low to FSMC_A valid	-	TBD	ns
$t_{h(A_NWE)}$	Address hold time after FSMC_NWE high	T_{HCLK}	-	ns
$t_{v(BL_NE)}$	FSMC_NEx low to FSMC_BL valid	-	TBD	ns
$t_{h(BL_NWE)}$	FSMC_BL hold time after FSMC_NWE high	TBD	-	ns
$t_{v(Data_NE)}$	FSMC_NEx low to Data valid	-	TBD	ns
$t_{h(Data_NWE)}$	Data hold time after FSMC_NWE high	T_{HCLK}	-	ns
$t_{v(NADV_NE)}$	FSMC_NEx low to FSMC_NADV low	-	TBD	ns
$t_{w(NADV)}$	FSMC_NADV low time	-	TBD	ns

1. $C_L = 15$ pF.
2. Preliminary values.

Figure 17. Asynchronous multiplexed PSRAM/NOR read waveforms

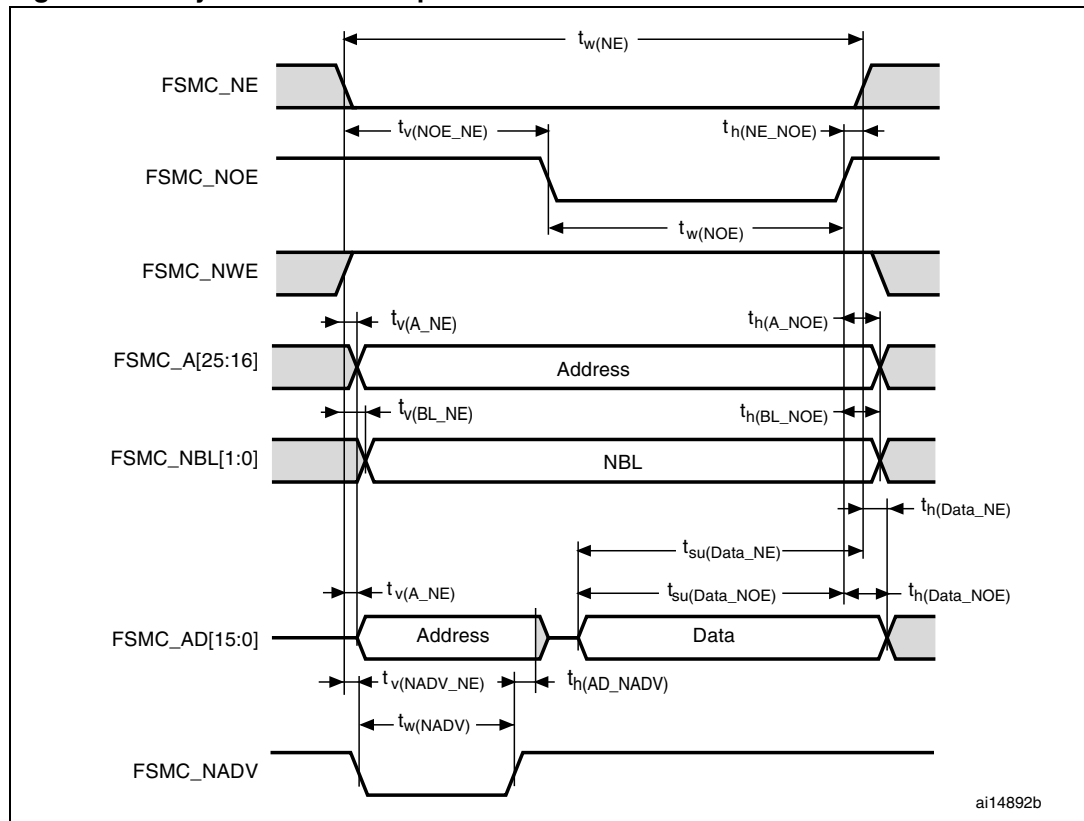

Table 39. Asynchronous multiplexed PSRAM/NOR read timings⁽¹⁾⁽²⁾

Symbol	Parameter	Min	Max	Unit
$t_{w(NE)}$	FSMC_NE low time	TBD	TBD	ns
$t_{v(NOE_NE)}$	FSMC_NEx low to FSMC_NOE low	TBD	TBD	ns
$t_{w(NOE)}$	FSMC_NOE low time	TBD	TBD	ns
$t_{h(NE_NOE)}$	FSMC_NOE high to FSMC_NE high hold time	TBD	-	ns
$t_{v(A_NE)}$	FSMC_NEx low to FSMC_A valid	-	0	ns
$t_{v(NADV_NE)}$	FSMC_NEx low to FSMC_NADV low	TBD	TBD	ns
$t_{w(NADV)}$	FSMC_NADV low time	TBD	TBD	ns
$t_{h(AD_NADV)}$	FSMC_AD (address) valid hold time after FSMC_NADV high	T_{HCLK}	-	ns
$t_{h(A_NOE)}$	Address hold time after FSMC_NOE high	T_{HCLK}	-	ns
$t_{h(BL_NOE)}$	FSMC_BL hold time after FSMC_NOE high	0	-	ns
$t_{v(BL_NE)}$	FSMC_NEx low to FSMC_BL valid	-	0	ns
$t_{su(Data_NE)}$	Data to FSMC_NEx high setup time	TBD	-	ns
$t_{su(Data_NOE)}$	Data to FSMC_NOE high setup time	TBD	-	ns
$t_{h(Data_NE)}$	Data hold time after FSMC_NEx high	0	-	ns
$t_{h(Data_NOE)}$	Data hold time after FSMC_NOE high	0	-	ns

1. $C_L = 15$ pF.
2. Preliminary values.

Figure 18. Asynchronous multiplexed PSRAM/NOR write waveforms

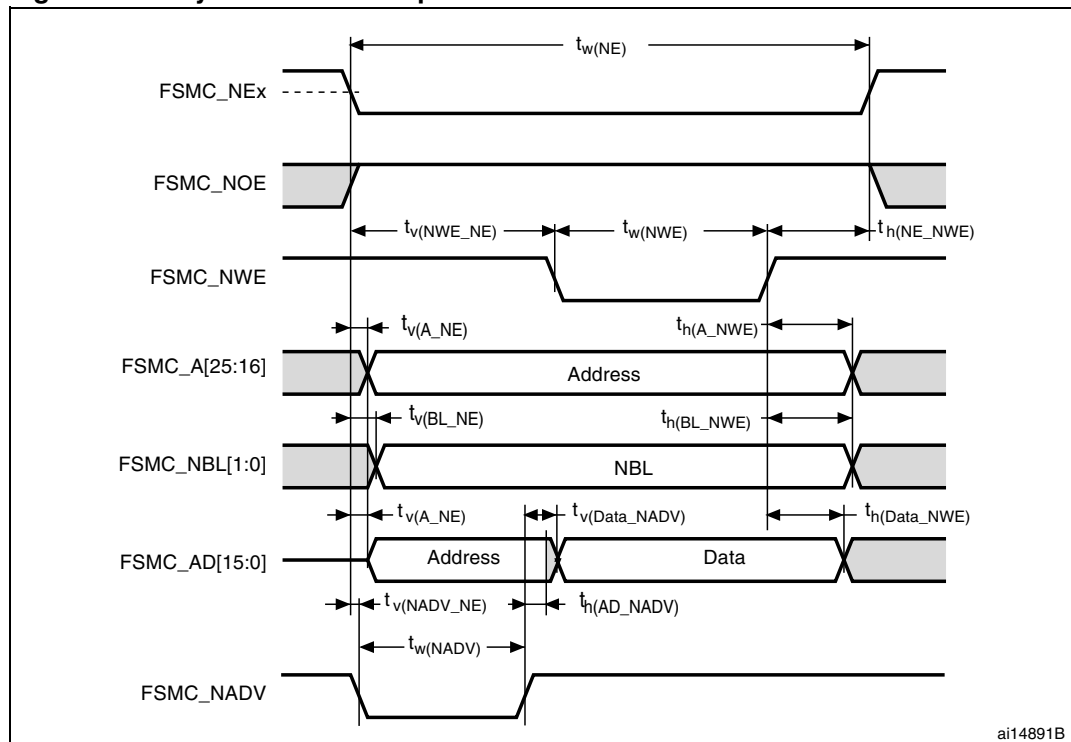

Table 40. Asynchronous multiplexed PSRAM/NOR write timings⁽¹⁾⁽²⁾

Symbol	Parameter	Min	Max	Unit
$t_{w(NE)}$	FSMC_NE low time	TBD	TBD	ns
$t_{v(NWE_NE)}$	FSMC_NEx low to FSMC_NWE low	$2T_{HCLK}$	TBD	ns
$t_{w(NWE)}$	FSMC_NWE low time	TBD	TBD	ns
$t_{h(NE_NWE)}$	FSMC_NWE high to FSMC_NE high hold time	TBD	-	ns
$t_{v(A_NE)}$	FSMC_NEx low to FSMC_A valid	-	TBD	ns
$t_{v(NADV_NE)}$	FSMC_NEx low to FSMC_NADV low	TBD	TBD	ns
$t_{w(NADV)}$	FSMC_NADV low time	TBD	TBD	ns
$t_{h(AD_NADV)}$	FSMC_AD (address) valid hold time after FSMC_NADV high	TBD	-	ns
$t_{h(A_NWE)}$	Address hold time after FSMC_NWE high	TBD	-	ns
$t_{v(BL_NE)}$	FSMC_NEx low to FSMC_BL valid	-	TBD	ns
$t_{h(BL_NWE)}$	FSMC_BL hold time after FSMC_NWE high	TBD	-	ns
$t_{v(Data_NADV)}$	FSMC_NADV high to Data valid	-	TBD	ns
$t_{h(Data_NWE)}$	Data hold time after FSMC_NWE high	TBD	-	ns

1. $C_L = 15$ pF.

2. Preliminary values.

Table 41. Synchronous multiplexed NOR/PSRAM read timings⁽¹⁾⁽²⁾

Symbol	Parameter	Min	Max	Unit
$t_{w(\text{CLK})}$	FSMC_CLK period	$2 \cdot T_{\text{HCLK}}$	-	ns
$t_{d(\text{CLKL-NExL})}$	FSMC_CLK low to FSMC_NEx low ($x = 0 \dots 2$)	-	TBD	ns
$t_{d(\text{CLKL-NExH})}$	FSMC_CLK low to FSMC_NEx high ($x = 0 \dots 2$)	TBD	-	ns
$t_{d(\text{CLKL-NADVl})}$	FSMC_CLK low to FSMC_NADV low	-	TBD	ns
$t_{d(\text{CLKL-NADVh})}$	FSMC_CLK low to FSMC_NADV high	TBD	-	ns
$t_{d(\text{CLKL-AV})}$	FSMC_CLK low to FSMC_Ax valid ($x = 16 \dots 25$)	-	0	ns
$t_{d(\text{CLKL-AIV})}$	FSMC_CLK low to FSMC_Ax invalid ($x = 16 \dots 25$)	TBD	-	ns
$t_{d(\text{CLKL-NOEL})}$	FSMC_CLK low to FSMC_NOE low	-	TBD	ns
$t_{d(\text{CLKL-NOEH})}$	FSMC_CLK low to FSMC_NOE high	TBD	-	ns
$t_{d(\text{CLKL-ADV})}$	FSMC_CLK low to FSMC_AD[15:0] valid	-	TBD	ns
$t_{d(\text{CLKL-ADIV})}$	FSMC_CLK low to FSMC_AD[15:0] invalid	0	-	ns
$t_{su(\text{ADV-CLKH})}$	FSMC_A/D[15:0] valid data before FSMC_CLK high	TBD	-	ns
$t_h(\text{CLKH-ADV})$	FSMC_A/D[15:0] valid data after FSMC_CLK high	0	-	ns
$t_{su(\text{NWAITV-CLKH})}$	FSMC_NWAIT valid before FSMC_CLK high	TBD	-	ns
$t_h(\text{CLKH-NWAITV})$	FSMC_NWAIT valid after FSMC_CLK high	TBD	-	ns

1. $C_L = 15 \text{ pF}$.

2. Preliminary values.

Figure 20. Synchronous multiplexed PSRAM write timings

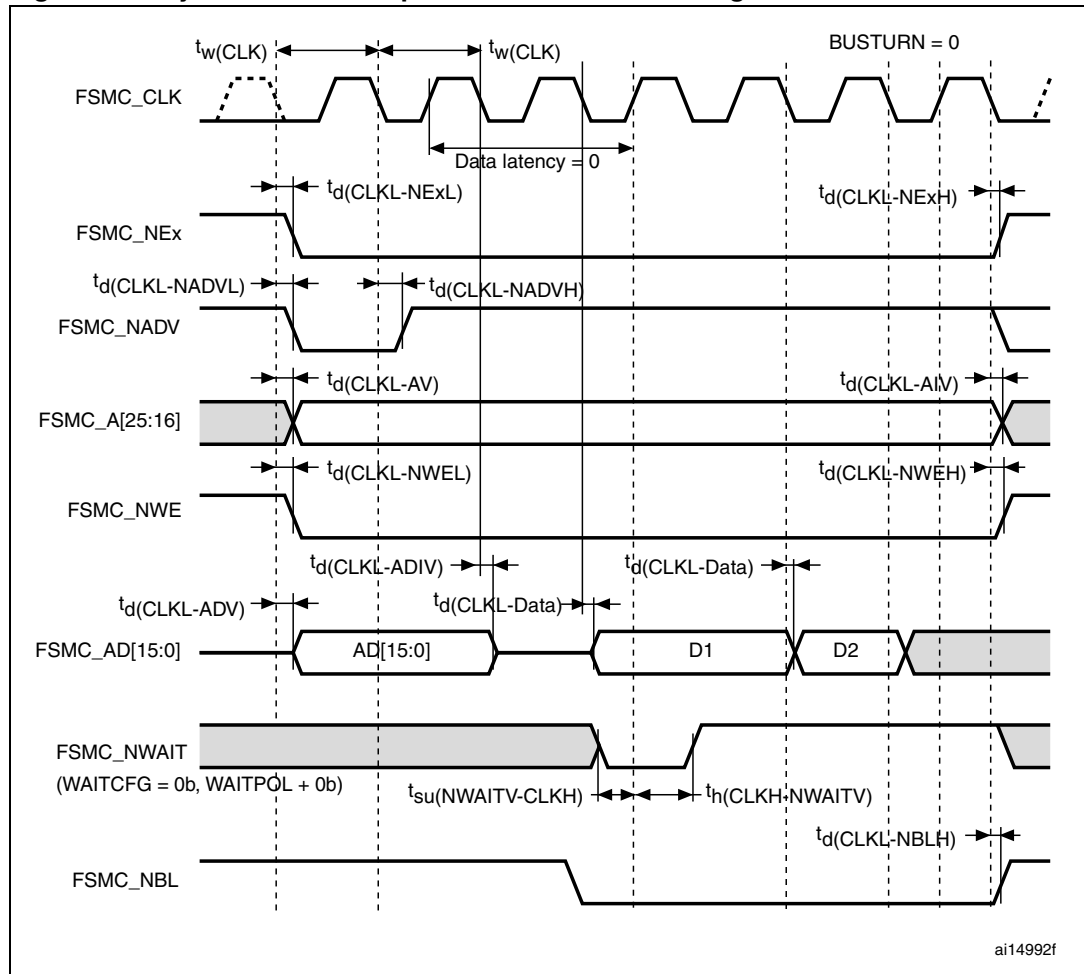

Table 42. Synchronous multiplexed PSRAM write timings⁽¹⁾⁽²⁾

Symbol	Parameter	Min	Max	Unit
$t_{w(CLK)}$	FSMC_CLK period	$2 \cdot T_{HCLK}$	-	ns
$t_{d(CLKL-NExL)}$	FSMC_CLK low to FSMC_Nex low (x = 0...2)	-	TBD	ns
$t_{d(CLKL-NExH)}$	FSMC_CLK low to FSMC_NEx high (x = 0...2)	TBD	-	ns
$t_{d(CLKL-NADVl)}$	FSMC_CLK low to FSMC_NADV low	-	TBD	ns
$t_{d(CLKL-NADVh)}$	FSMC_CLK low to FSMC_NADV high	TBD	-	ns
$t_{d(CLKL-AV)}$	FSMC_CLK low to FSMC_Ax valid (x = 16...25)	-	0	ns
$t_{d(CLKL-AIV)}$	FSMC_CLK low to FSMC_Ax invalid (x = 16...25)	TBD	-	ns
$t_{d(CLKL-NWEL)}$	FSMC_CLK low to FSMC_NWE low	-	TBD	ns
$t_{d(CLKL-NWEH)}$	FSMC_CLK low to FSMC_NWE high	TBD	-	ns
$t_{d(CLKL-ADV)}$	FSMC_CLK low to FSMC_AD[15:0] valid	-	TBD	ns
$t_{d(CLKL-ADIV)}$	FSMC_CLK low to FSMC_AD[15:0] invalid	TBD	-	ns
$t_{d(CLKL-Data)}$	FSMC_A/D[15:0] valid after FSMC_CLK low	-	TBD	ns
$t_{su(NWAITV-CLKH)}$	FSMC_NWAIT valid before FSMC_CLK high	TBD	-	ns
$t_h(CLKH-NWAITV)$	FSMC_NWAIT valid after FSMC_CLK high	TBD	-	ns
$t_{d(CLKL-NBLH)}$	FSMC_CLK low to FSMC_NBL high	TBD	-	ns

1. $C_L = 15$ pF.
2. Preliminary values

Figure 21. Synchronous non-multiplexed NOR/PSRAM read timings

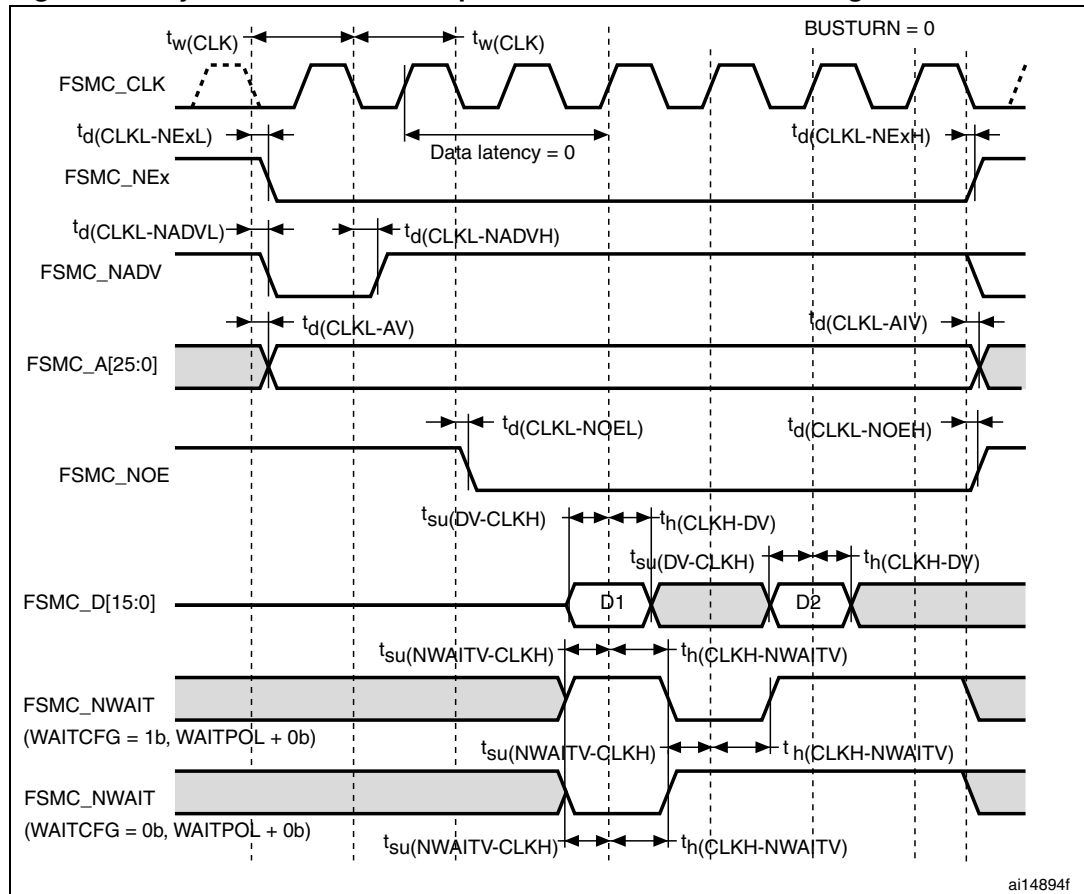

Table 43. Synchronous non-multiplexed NOR/PSRAM read timings⁽¹⁾⁽²⁾

Symbol	Parameter	Min	Max	Unit
$t_w(\text{CLK})$	FSMC_CLK period	$2 \cdot T_{\text{HCLK}}$	-	ns
$t_d(\text{CLKL-NExL})$	FSMC_CLK low to FSMC_NEx low ($x = 0 \dots 2$)	-	TBD	ns
$t_d(\text{CLKL-NExH})$	FSMC_CLK low to FSMC_NEx high ($x = 0 \dots 2$)	TBD	-	ns
$t_d(\text{CLKL-NADVl})$	FSMC_CLK low to FSMC_NADV low	-	TBD	ns
$t_d(\text{CLKL-NADVh})$	FSMC_CLK low to FSMC_NADV high	TBD	-	ns
$t_d(\text{CLKL-AV})$	FSMC_CLK low to FSMC_Ax valid ($x = 0 \dots 25$)	-	0	ns
$t_d(\text{CLKL-AIV})$	FSMC_CLK low to FSMC_Ax invalid ($x = 0 \dots 25$)	TBD	-	ns
$t_d(\text{CLKL-NOEL})$	FSMC_CLK low to FSMC_NOE low	-	TBD	ns
$t_d(\text{CLKL-NOEH})$	FSMC_CLK low to FSMC_NOE high	TBD	-	ns
$t_{su}(\text{DV-CLKH})$	FSMC_D[15:0] valid data before FSMC_CLK high	TBD	-	ns
$t_h(\text{CLKH-DV})$	FSMC_D[15:0] valid data after FSMC_CLK high	TBD	-	ns
$t_{su}(\text{NWAITV-CLKH})$	FSMC_NWAIT valid before FSMC_SMCLK high	TBD	-	ns
$t_h(\text{CLKH-NWAITV})$	FSMC_NWAIT valid after FSMC_CLK high	TBD	-	ns

1. $C_L = 15 \text{ pF}$.
2. Preliminary values.

Figure 22. Synchronous non-multiplexed PSRAM write timings

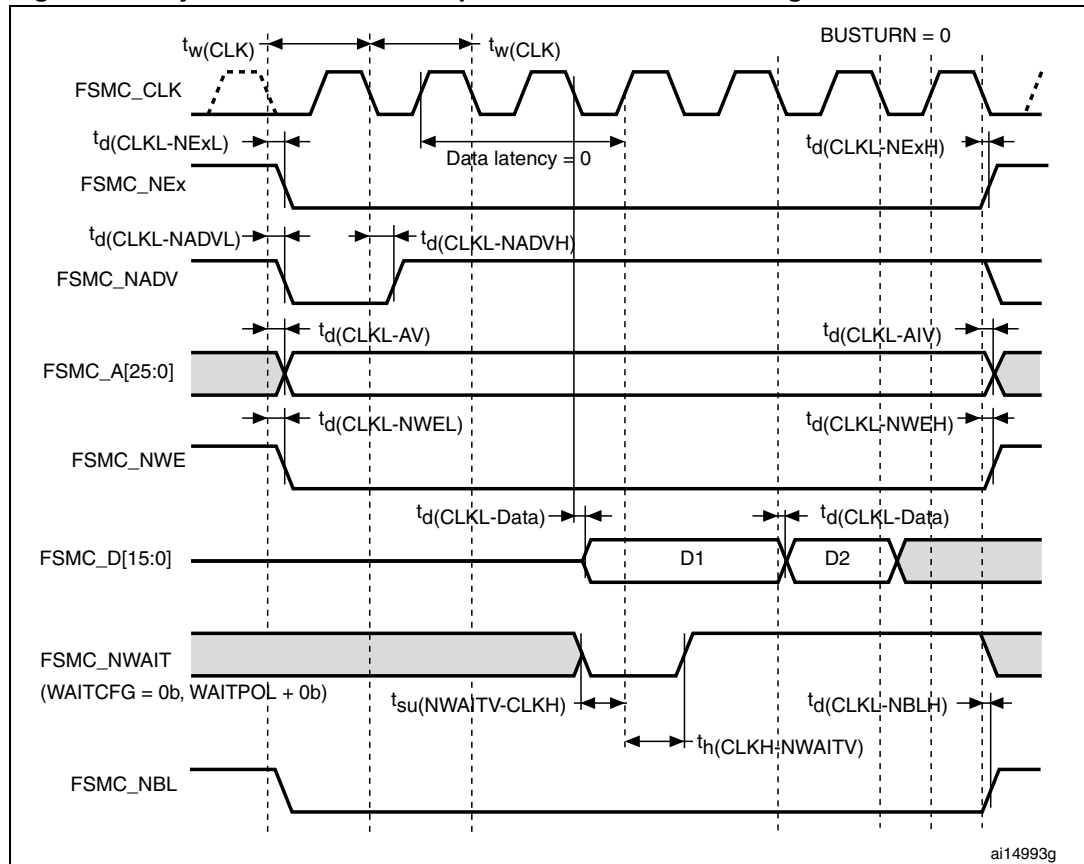

Table 44. Synchronous non-multiplexed PSRAM write timings⁽¹⁾⁽²⁾

Symbol	Parameter	Min	Max	Unit
$t_w(\text{CLK})$	FSMC_CLK period	$2 \cdot T_{\text{HCLK}}$	-	ns
$t_d(\text{CLKL-NExL})$	FSMC_CLK low to FSMC_NEx low (x = 0...2)	-	TBD	ns
$t_d(\text{CLKL-NExH})$	FSMC_CLK low to FSMC_NEx high (x = 0...2)	TBD	-	ns
$t_d(\text{CLKL-NADVL})$	FSMC_CLK low to FSMC_NADV low	-	TBD	ns
$t_d(\text{CLKL-NADVH})$	FSMC_CLK low to FSMC_NADV high	TBD	-	ns
$t_d(\text{CLKL-AV})$	FSMC_CLK low to FSMC_Ax valid (x = 16...25)	-	0	ns
$t_d(\text{CLKL-AIV})$	FSMC_CLK low to FSMC_Ax invalid (x = 16...25)	TBD	-	ns
$t_d(\text{CLKL-NWEL})$	FSMC_CLK low to FSMC_NWE low	-	TBD	ns
$t_d(\text{CLKL-NWEH})$	FSMC_CLK low to FSMC_NWE high	TBD	-	ns
$t_d(\text{CLKL-Data})$	FSMC_D[15:0] valid data after FSMC_CLK low	-	TBD	ns
$t_{su}(\text{NWAITV-CLKH})$	FSMC_NWAIT valid before FSMC_CLK high	TBD	-	ns
$t_h(\text{CLKH-NWAITV})$	FSMC_NWAIT valid after FSMC_CLK high	TBD	-	ns
$t_d(\text{CLKL-NBLH})$	FSMC_CLK low to FSMC_NBL high	TBD	-	ns

1. $C_L = 15 \text{ pF}$.
2. Preliminary values.

6.3.10 EMC characteristics

Susceptibility tests are performed on a sample basis during device characterization.

Functional EMS (electromagnetic susceptibility)

While a simple application is executed on the device (toggling 2 LEDs through I/O ports), the device is stressed by two electromagnetic events until a failure occurs. The failure is indicated by the LEDs:

- **Electrostatic discharge (ESD)** (positive and negative) is applied to all device pins until a functional disturbance occurs. This test is compliant with the IEC 61000-4-2 standard.
- **FTB: A Burst of Fast Transient voltage** (positive and negative) is applied to V_{DD} and V_{SS} through a 100 pF capacitor, until a functional disturbance occurs. This test is compliant with the IEC 61000-4-4 standard.

A device reset allows normal operations to be resumed.

The test results are given in [Table 45](#). They are based on the EMS levels and classes defined in application note AN1709.

Table 45. EMS characteristics

Symbol	Parameter	Conditions	Level/Class
V_{FESD}	Voltage limits to be applied on any I/O pin to induce a functional disturbance	$V_{DD} = 3.3\text{ V}$, LQFP100, $T_A = +25\text{ °C}$, $f_{HCLK} = 32\text{ MHz}$ conforms to IEC 61000-4-2	2B
V_{EFTB}	Fast transient voltage burst limits to be applied through 100 pF on V_{DD} and V_{SS} pins to induce a functional disturbance	$V_{DD} = 3.3\text{ V}$, LQFP100, $T_A = +25\text{ °C}$, $f_{HCLK} = 32\text{ MHz}$ conforms to IEC 61000-4-4	4A

Designing hardened software to avoid noise problems

EMC characterization and optimization are performed at component level with a typical application environment and simplified MCU software. It should be noted that good EMC performance is highly dependent on the user application and the software in particular.

Therefore it is recommended that the user applies EMC software optimization and prequalification tests in relation with the EMC level requested for his application.

Software recommendations

The software flowchart must include the management of runaway conditions such as:

- Corrupted program counter
- Unexpected reset
- Critical data corruption (control registers...)

Prequalification trials

Most of the common failures (unexpected reset and program counter corruption) can be reproduced by manually forcing a low state on the NRST pin or the oscillator pins for 1 second.

To complete these trials, ESD stress can be applied directly on the device, over the range of specification values. When unexpected behavior is detected, the software can be hardened to prevent unrecoverable errors occurring (see application note AN1015).

Electromagnetic Interference (EMI)

The electromagnetic field emitted by the device are monitored while a simple application is executed (toggling 2 LEDs through the I/O ports). This emission test is compliant with IEC 61967-2 standard which specifies the test board and the pin loading.

Table 46. EMI characteristics

Symbol	Parameter	Conditions	Monitored frequency band	Max vs. frequency range			Unit
				4 MHz voltage range 3	16 MHz voltage range 2	32 MHz voltage range 1	
S _{EMI}	Peak level	V _{DD} = 3.3 V, T _A = 25 °C, LQFP100 package compliant with IEC 61967-2	0.1 to 30 MHz	3	-6	-5	dBµV
			30 to 130 MHz	18	4	-7	
			130 MHz to 1GHz	15	5	-7	
			SAE EMI Level	2.5	2	1	-

6.3.11 Absolute maximum ratings (electrical sensitivity)

Based on three different tests (ESD, LU) using specific measurement methods, the device is stressed in order to determine its performance in terms of electrical sensitivity.

Electrostatic discharge (ESD)

Electrostatic discharges (a positive then a negative pulse separated by 1 second) are applied to the pins of each sample according to each pin combination. The sample size depends on the number of supply pins in the device (3 parts × (n+1) supply pins). This test conforms to the JESD22-A114/C101 standard.

Table 47. ESD absolute maximum ratings

Symbol	Ratings	Conditions	Class	Maximum value ⁽¹⁾	Unit
V _{ESD(HBM)}	Electrostatic discharge voltage (human body model)	T _A = +25 °C, conforming to JESD22-A114	2	2000	V
V _{ESD(CDM)}	Electrostatic discharge voltage (charge device model)	T _A = +25 °C, conforming to JESD22-C101	II	500	

1. Based on characterization results, not tested in production.

Static latch-up

Two complementary static tests are required on six parts to assess the latch-up performance:

- A supply overvoltage is applied to each power supply pin
- A current injection is applied to each input, output and configurable I/O pin

These tests are compliant with EIA/JESD 78A IC latch-up standard.

Table 48. Electrical sensitivities

Symbol	Parameter	Conditions	Class
LU	Static latch-up class	T _A = +105 °C conforming to JESD78A	II level A

6.3.12 I/O current injection characteristics

As a general rule, current injection to the I/O pins, due to external voltage below V_{SS} or above V_{DD} (for standard pins) should be avoided during normal product operation. However, in order to give an indication of the robustness of the microcontroller in cases when abnormal injection accidentally happens, susceptibility tests are performed on a sample basis during device characterization.

Functional susceptibility to I/O current injection

While a simple application is executed on the device, the device is stressed by injecting current into the I/O pins programmed in floating input mode. While current is injected into the I/O pin, one at a time, the device is checked for functional failures.

The failure is indicated by an out of range parameter: ADC error, out of spec current injection on adjacent pins or other functional failure (for example reset, oscillator frequency deviation, LCD levels, etc.).

The test results are given in the following table.

Table 49. I/O current injection susceptibility

Symbol	Description	Functional susceptibility		Unit
		Negative injection	Positive injection	
I _{INJ}	Injected current on true open-drain pins	-5	+0	mA
	Injected current on all 5 V tolerant (FT) pins	-5	+0	
	Injected current on any other pin	-5	+5	

6.3.13 I/O port characteristics

General input/output characteristics

Unless otherwise specified, the parameters given in [Table 50](#) are derived from tests performed under the conditions summarized in [Table 13](#). All I/Os are CMOS and TTL compliant.

Table 50. I/O static characteristics

Symbol	Parameter	Conditions	Min	Typ	Max	Unit
V_{IL}	Input low level voltage	TTL ports $2.7\text{ V} \leq V_{DD} \leq 3.6\text{ V}$	$V_{SS} - 0.3$	-	0.8	V
V_{IH}	Standard I/O input high level voltage		$2^{(1)}$	-	$V_{DD} + 0.3$	
	FT ⁽²⁾ I/O input high level voltage	-	-	5.5V		
V_{IL}	Input low level voltage	CMOS ports $1.65\text{ V} \leq V_{DD} \leq 3.6\text{ V}$	-0.3	-	$0.3V_{DD}^{(3)}$	V
V_{IH}	Standard I/O Input high level voltage	CMOS ports $1.65\text{ V} \leq V_{DD} \leq 3.6\text{ V}$	$0.7 V_{DD}^{(3)(4)}$	-	$V_{DD} + 0.3$	
	FT ⁽⁵⁾ I/O input high level voltage	CMOS ports $1.65\text{ V} \leq V_{DD} \leq 2.0\text{ V}$		-	5.25	
		CMOS ports $2.0\text{ V} \leq V_{DD} \leq 3.6\text{ V}$		-	5.5	
V_{hys}	Standard I/O Schmitt trigger voltage hysteresis ⁽⁶⁾		$10\% V_{DD}^{(7)}$	-	-	
I_{lkg}	Input leakage current ⁽⁸⁾⁽³⁾	$V_{SS} \leq V_{IN} \leq V_{DD}$ I/Os with LCD	-	-	± 50	nA
		$V_{SS} \leq V_{IN} \leq V_{DD}$ I/Os with analog switches	-	-	± 50	
		$V_{SS} \leq V_{IN} \leq V_{DD}$ I/Os with analog switches and LCD	-	-	± 50	
		$V_{SS} \leq V_{IN} \leq V_{DD}$ I/Os with USB	-	-	TBD	
		$V_{SS} \leq V_{IN} \leq V_{DD}$ Standard I/Os	-	-	± 50	
R_{PU}	Weak pull-up equivalent resistor ⁽⁹⁾⁽³⁾	$V_{IN} = V_{SS}$	30	45	60	k Ω
R_{PD}	Weak pull-down equivalent resistor ⁽⁹⁾⁽³⁾	$V_{IN} = V_{DD}$	30	45	60	k Ω
C_{IO}	I/O pin capacitance		-	5	-	pF

1. Guaranteed by design.
2. FT = 5V tolerant. To sustain a voltage higher than $V_{DD} + 0.5$ the internal pull-up/pull-down resistors must be disabled.
3. Tested in production
4. $0.7V_{DD}$ for 5V-tolerant receiver
5. FT = Five-volt tolerant.
6. Hysteresis voltage between Schmitt trigger switching levels. Based on characterization, not tested in production.
7. With a minimum of 200 mV. Based on characterization, not tested in production.

- 8. The max. value may be exceeded if negative current is injected on adjacent pins.
- 9. Pull-up and pull-down resistors are designed with a true resistance in series with a switchable PMOS/NMOS. This MOS/NMOS contribution to the series resistance is minimum (~10% order).

Output driving current

The GPIOs (general purpose input/outputs) can sink or source up to ±8 mA, and sink or source up to ±20 mA with the non-standard V_{OL}/V_{OH} specifications given in [Table 51](#).

in the user application, the number of I/O pins which can drive current must be limited to respect the absolute maximum rating specified in [Section 6.2](#):

- The sum of the currents sourced by all the I/Os on V_{DD} , plus the maximum Run consumption of the MCU sourced on V_{DD} , cannot exceed the absolute maximum rating I_{VDD} (see [Table 11](#)).
- The sum of the currents sunk by all the I/Os on V_{SS} plus the maximum Run consumption of the MCU sunk on V_{SS} cannot exceed the absolute maximum rating I_{VSS} (see [Table 11](#)).

Output voltage levels

Unless otherwise specified, the parameters given in [Table 51](#) are derived from tests performed under ambient temperature and V_{DD} supply voltage conditions summarized in [Table 13](#). All I/Os are CMOS and TTL compliant.

Table 51. Output voltage characteristics

Symbol	Parameter	Conditions	Min	Max	Unit
$V_{OL}^{(1)(2)}$	Output low level voltage for an I/O pin when 8 pins are sunk at same time	$I_{IO} = +8 \text{ mA}$ $2.7 \text{ V} < V_{DD} < 3.6 \text{ V}$	-	0.4	V
$V_{OH}^{(3)(2)}$	Output high level voltage for an I/O pin when 8 pins are sourced at same time		2.4	-	
$V_{OL}^{(1)(4)}$	Output low level voltage for an I/O pin when 8 pins are sunk at same time	$I_{IO} = +4 \text{ mA}$ $1.65 \text{ V} < V_{DD} < 2.7 \text{ V}$	-	0.45	
$V_{OH}^{(3)(4)}$	Output high level voltage for an I/O pin when 8 pins are sourced at same time		$V_{DD}-0.45$	-	
$V_{OL}^{(1)(4)}$	Output low level voltage for an I/O pin when 4 pins are sunk at same time	$I_{IO} = +20 \text{ mA}$ $2.7 \text{ V} < V_{DD} < 3.6 \text{ V}$	-	1.3	
$V_{OH}^{(3)(4)}$	Output high level voltage for an I/O pin when 4 pins are sourced at same time		$V_{DD}-1.3$	-	

1. The I_{IO} current sunk by the device must always respect the absolute maximum rating specified in [Table 11](#) and the sum of I_{IO} (I/O ports and control pins) must not exceed I_{VSS} .
2. Tested in production.
3. The I_{IO} current sourced by the device must always respect the absolute maximum rating specified in [Table 11](#) and the sum of I_{IO} (I/O ports and control pins) must not exceed I_{VDD} .
4. Based on characterization data, not tested in production.

Input/output AC characteristics

The definition and values of input/output AC characteristics are given in [Figure 23](#) and [Table 52](#), respectively.

Unless otherwise specified, the parameters given in [Table 52](#) are derived from tests performed under ambient temperature and V_{DD} supply voltage conditions summarized in [Table 13](#).

Table 52. I/O AC characteristics⁽¹⁾

OSPEEDRx [1:0] bit value ⁽¹⁾	Symbol	Parameter	Conditions	Min	Max ⁽²⁾	Unit
00	$f_{\max(\text{IO})\text{out}}$	Maximum frequency ⁽³⁾	$C_L = 50 \text{ pF}, V_{DD} = 2.7 \text{ V to } 3.6 \text{ V}$	-	400	kHz
			$C_L = 50 \text{ pF}, V_{DD} = 1.65 \text{ V to } 2.7 \text{ V}$	-	TBD	
	$t_{f(\text{IO})\text{out}}$ $t_{r(\text{IO})\text{out}}$	Output rise and fall time	$C_L = 50 \text{ pF}, V_{DD} = 2.7 \text{ V to } 3.6 \text{ V}$	-	625	ns
			$C_L = 50 \text{ pF}, V_{DD} = 1.65 \text{ V to } 2.7 \text{ V}$	-	TBD	
01	$f_{\max(\text{IO})\text{out}}$	Maximum frequency ⁽³⁾	$C_L = 50 \text{ pF}, V_{DD} = 2.7 \text{ V to } 3.6 \text{ V}$	-	2	MHz
			$C_L = 50 \text{ pF}, V_{DD} = 1.65 \text{ V to } 2.7 \text{ V}$	-	1	
	$t_{f(\text{IO})\text{out}}$ $t_{r(\text{IO})\text{out}}$	Output rise and fall time	$C_L = 50 \text{ pF}, V_{DD} = 2.7 \text{ V to } 3.6 \text{ V}$	-	125	ns
			$C_L = 50 \text{ pF}, V_{DD} = 1.65 \text{ V to } 2.7 \text{ V}$	-	TBD	
10	$F_{\max(\text{IO})\text{out}}$	Maximum frequency ⁽³⁾	$C_L = 50 \text{ pF}, V_{DD} = 2.7 \text{ V to } 3.6 \text{ V}$	-	10	MHz
			$C_L = 50 \text{ pF}, V_{DD} = 1.65 \text{ V to } 2.7 \text{ V}$	-	2	
	$t_{f(\text{IO})\text{out}}$ $t_{r(\text{IO})\text{out}}$	Output rise and fall time	$C_L = 50 \text{ pF}, V_{DD} = 2.7 \text{ V to } 3.6 \text{ V}$	-	25	ns
			$C_L = 50 \text{ pF}, V_{DD} = 1.65 \text{ V to } 2.7 \text{ V}$	-	TBD	
11	$F_{\max(\text{IO})\text{out}}$	Maximum frequency ⁽³⁾	$C_L = 50 \text{ pF}, V_{DD} = 2.7 \text{ V to } 3.6 \text{ V}$	-	50	MHz
			$C_L = 50 \text{ pF}, V_{DD} = 1.65 \text{ V to } 2.7 \text{ V}$	-	8	
	$t_{f(\text{IO})\text{out}}$ $t_{r(\text{IO})\text{out}}$	Output rise and fall time	$C_L = 30 \text{ pF}, V_{DD} = 2.7 \text{ V to } 3.6 \text{ V}$	-	5	ns
			$C_L = 50 \text{ pF}, V_{DD} = 1.65 \text{ V to } 2.7 \text{ V}$	-	TBD	
-	$t_{\text{EXTI}pw}$	Pulse width of external signals detected by the EXTI controller		8	-	ns

1. The I/O speed is configured using the OSPEEDRx[1:0] bits. Refer to the STM32L151xx, STM32L152xx and STM32L162xx reference manual for a description of GPIO Port configuration register.
2. Guaranteed by design. Not tested in production.
3. The maximum frequency is defined in [Figure 23](#).

Figure 23. I/O AC characteristics definition

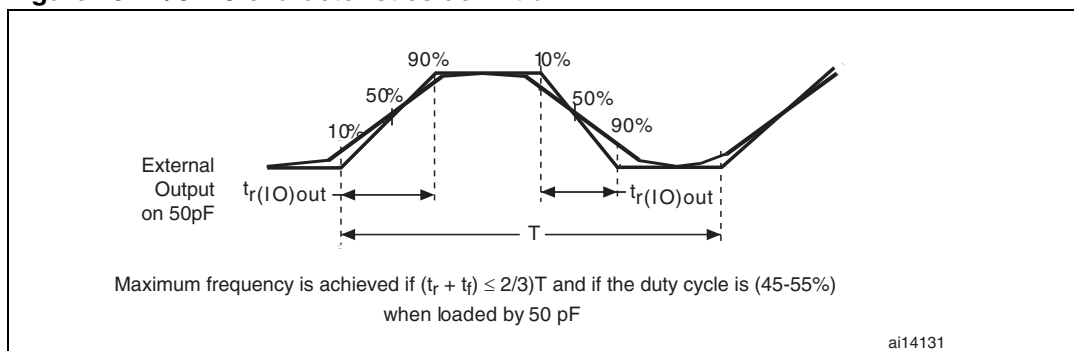

6.3.14 NRST pin characteristics

The NRST pin input driver uses CMOS technology.

Unless otherwise specified, the parameters given in [Table 53](#) are derived from tests performed under ambient temperature and V_{DD} supply voltage conditions summarized in [Table 13](#).

Table 53. NRST pin characteristics

Symbol	Parameter	Conditions	Min	Typ	Max	Unit
$V_{IL(NRST)}^{(1)}$	NRST input low level voltage		V_{SS}	-	0.8	V
$V_{IH(NRST)}^{(1)}$	NRST input high level voltage		1.4	-	V_{DD}	
$V_{OL(NRST)}^{(1)}$	NRST output low level voltage	$I_{OL} = 2 \text{ mA}$ $2.7 \text{ V} < V_{DD} < 3.6 \text{ V}$ $I_{OL} = 1.5 \text{ mA}$ $1.65 \text{ V} < V_{DD} < 2.7 \text{ V}$	-	-	0.4	
$V_{hys(NRST)}^{(1)}$	NRST Schmitt trigger voltage hysteresis		$10\%V_{DD}^{(2)}$	-	-	mV
R_{PU}	Weak pull-up equivalent resistor ⁽³⁾	$V_{IN} = V_{SS}$	30	45	60	k Ω
$V_{F(NRST)}^{(1)}$	NRST input filtered pulse		-	-	50	ns
$V_{NF(NRST)}^{(1)}$	NRST input not filtered pulse		350	-	-	ns

1. Guaranteed by design, not tested in production.
2. 200 mV minimum value
3. The pull-up is designed with a true resistance in series with a switchable PMOS. This PMOS contribution to the series resistance is around 10%.

Figure 24. Recommended NRST pin protection

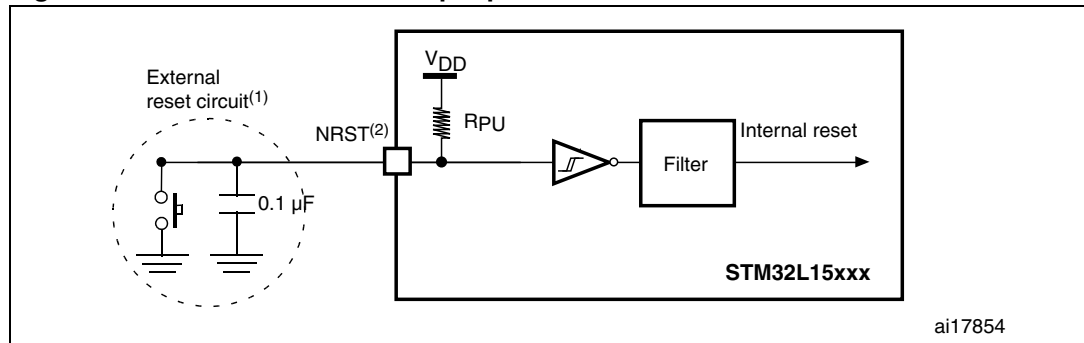

1. The reset network protects the device against parasitic resets.
2. The user must ensure that the level on the NRST pin can go below the $V_{IL(NRST)}$ max level specified in [Table 53](#). Otherwise the reset will not be taken into account by the device.

6.3.15 TIM timer characteristics

The parameters given in the following table are guaranteed by design.

Refer to [Section 6.3.12: I/O current injection characteristics](#) for details on the input/output alternate function characteristics (output compare, input capture, external clock, PWM output).

Table 54. TIMx⁽¹⁾ characteristics

Symbol	Parameter	Conditions	Min	Max	Unit
$t_{res(TIM)}$	Timer resolution time		1	-	$t_{TIMxCLK}$
		$f_{TIMxCLK} = 32 \text{ MHz}$	31.25	-	ns
f_{EXT}	Timer external clock frequency on CH1 to CH4		0	$f_{TIMxCLK}/2$	MHz
		$f_{TIMxCLK} = 32 \text{ MHz}$	0	16	MHz
Res_{TIM}	Timer resolution			16	bit
$t_{COUNTER}$	16-bit counter clock period when internal clock is selected (timer's prescaler disabled)		1	65536	$t_{TIMxCLK}$
		$f_{TIMxCLK} = 32 \text{ MHz}$	0.0312	2048	μs
t_{MAX_COUNT}	Maximum possible count		-	65536×65536	$t_{TIMxCLK}$
		$f_{TIMxCLK} = 32 \text{ MHz}$	-	134.2	s

1. TIMx is used as a general term to refer to the TIM2, TIM3 and TIM4 timers.

6.3.16 Communications interfaces

I²C interface characteristics

Unless otherwise specified, the parameters given in [Table 55](#) are derived from tests performed under ambient temperature, f_{PCLK1} frequency and V_{DD} supply voltage conditions summarized in [Table 13](#).

The STM32L151xD and STM32L152xD product line I²C interface meets the requirements of the standard I²C communication protocol with the following restrictions: SDA and SCL are not “true” open-drain I/O pins. When configured as open-drain, the PMOS connected between the I/O pin and V_{DD} is disabled, but is still present.

The I²C characteristics are described in [Table 55](#). Refer also to [Section 6.3.12: I/O current injection characteristics](#) for more details on the input/output alternate function characteristics (SDA and SCL).

Table 55. I²C characteristics

Symbol	Parameter	Standard mode I ² C ⁽¹⁾		Fast mode I ² C ⁽¹⁾⁽²⁾		Unit
		Min	Max	Min	Max	
$t_{w(SCLL)}$	SCL clock low time	4.7	-	1.3	-	μs
$t_{w(SCLH)}$	SCL clock high time	4.0	-	0.6	-	
$t_{su(SDA)}$	SDA setup time	250	-	100	-	ns
$t_h(SDA)$	SDA data hold time	0	-	0	900 ⁽³⁾	
$t_r(SDA)$ $t_r(SCL)$	SDA and SCL rise time	-	1000	$20 + 0.1C_b$	300	
$t_f(SDA)$ $t_f(SCL)$	SDA and SCL fall time	-	300	-	300	
$t_h(STA)$	Start condition hold time	4.0	-	0.6	-	
$t_{su(STA)}$	Repeated Start condition setup time	4.7	-	0.6	-	μs
$t_{su(STO)}$	Stop condition setup time	4.0	-	0.6	-	μs
$t_w(STO:STA)$	Stop to Start condition time (bus free)	4.7	-	1.3	-	μs
C_b	Capacitive load for each bus line	-	400	-	400	pF

1. Guaranteed by design, not tested in production.
2. f_{PCLK1} must be at least 2 MHz to achieve standard mode I²C frequencies. It must be at least 4 MHz to achieve fast mode I²C frequencies. It must be a multiple of 10 MHz to reach the 400 kHz maximum I²C fast mode clock.
3. The maximum Data hold time has only to be met if the interface does not stretch the low period of SCL signal.

Figure 25. I²C bus AC waveforms and measurement circuit

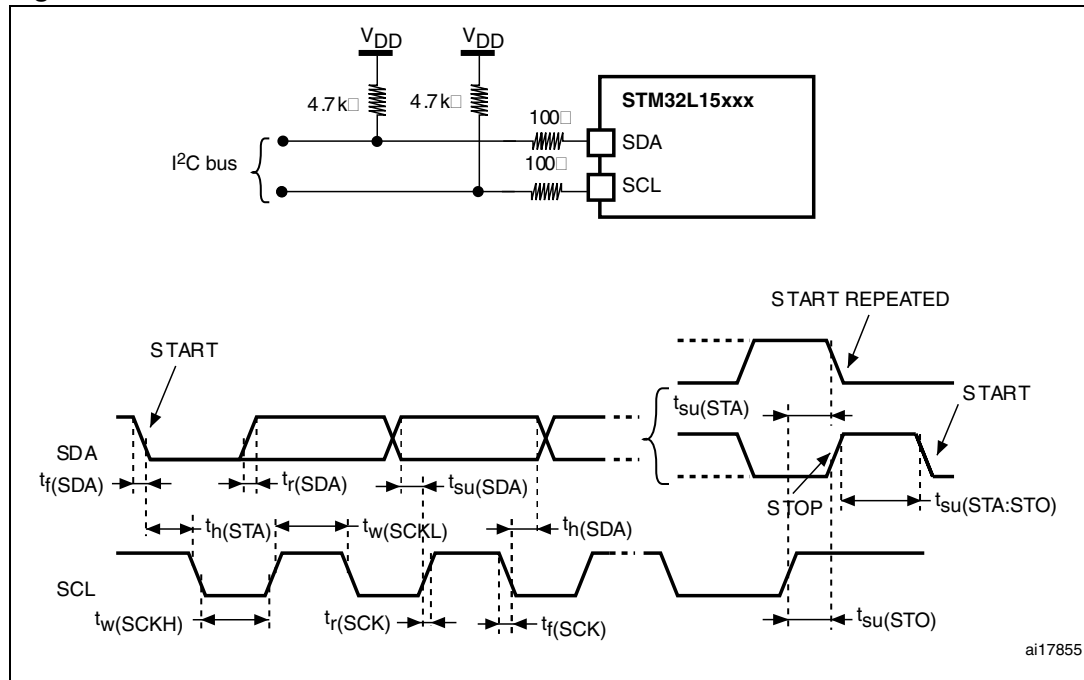

1. Measurement points are done at CMOS levels: 0.3V_{DD} and 0.7V_{DD}.

Table 56. SCL frequency (f_{PCLK1}= 32 MHz, V_{DD} = 3.3 V)⁽¹⁾⁽²⁾

f _{SCL} (kHz)	I2C_CCR value
	R _P = 4.7 kΩ
400	0x801B
300	0x8024
200	0x8035
100	0x00A0
50	0x0140
20	0x0320

1. R_P = External pull-up resistance, f_{SCL} = I²C speed.
2. For speeds around 200 kHz, the tolerance on the achieved speed is of ±5%. For other speed ranges, the tolerance on the achieved speed is ±2%. These variations depend on the accuracy of the external components used to design the application.

SPI characteristics

Unless otherwise specified, the parameters given in the following table are derived from tests performed under ambient temperature, f_{PCLKx} frequency and V_{DD} supply voltage conditions summarized in [Table 13](#).

Refer to [Section 6.3.12: I/O current injection characteristics](#) for more details on the input/output alternate function characteristics (NSS, SCK, MOSI, MISO).

Table 57. SPI characteristics⁽¹⁾

Symbol	Parameter	Conditions	Min	Max ⁽²⁾	Unit
f_{SCK} $1/t_{c(SCK)}$	SPI clock frequency	Master mode	-	16	MHz
		Slave mode	-	16	
		Slave transmitter	-	12 ⁽³⁾	
$t_{r(SCK)}^{(2)}$ $t_{f(SCK)}^{(2)}$	SPI clock rise and fall time	Capacitive load: C = 30 pF	-	6	ns
DuCy(SCK)	SPI slave input clock duty cycle	Slave mode	30	70	%
$t_{su(NSS)}$	NSS setup time	Slave mode	$4t_{HCLK}$	-	ns
$t_{h(NSS)}$	NSS hold time	Slave mode	$2t_{HCLK}$	-	
$t_{w(SCKH)}^{(2)}$ $t_{w(SCKL)}^{(2)}$	SCK high and low time	Master mode	$t_{SCK}/2-5$	$t_{SCK}/2+3$	
$t_{su(MI)}^{(2)}$	Data input setup time	Master mode	5	-	
$t_{su(SI)}^{(2)}$		Slave mode	6	-	
$t_{h(MI)}^{(2)}$	Data input hold time	Master mode	5	-	
$t_{h(SI)}^{(2)}$		Slave mode	5	-	
$t_{a(SO)}^{(4)}$	Data output access time	Slave mode	0	$3t_{HCLK}$	
$t_{v(SO)}^{(2)}$	Data output valid time	Slave mode	-	33	
$t_{v(MO)}^{(2)}$	Data output valid time	Master mode	-	6.5	
$t_{h(SO)}^{(2)}$	Data output hold time	Slave mode	17	-	
$t_{h(MO)}^{(2)}$		Master mode	0.5	-	

1. The characteristics above are given for voltage range 1.
2. Based on characterization, not tested in production.
3. The maximum SPI clock frequency in slave transmitter mode is given for an SPI slave input clock duty cycle (DuCy(SCK)) ranging between 40 to 60%.
4. Min time is for the minimum time to drive the output and max time is for the maximum time to validate the data.

Figure 26. SPI timing diagram - slave mode and CPHA = 0

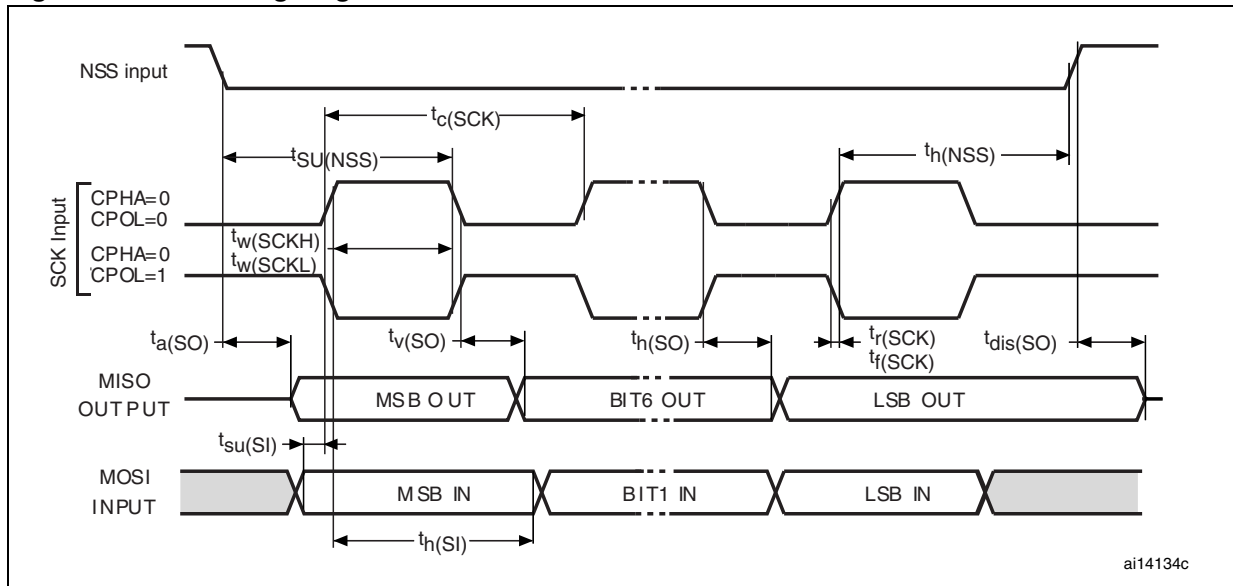
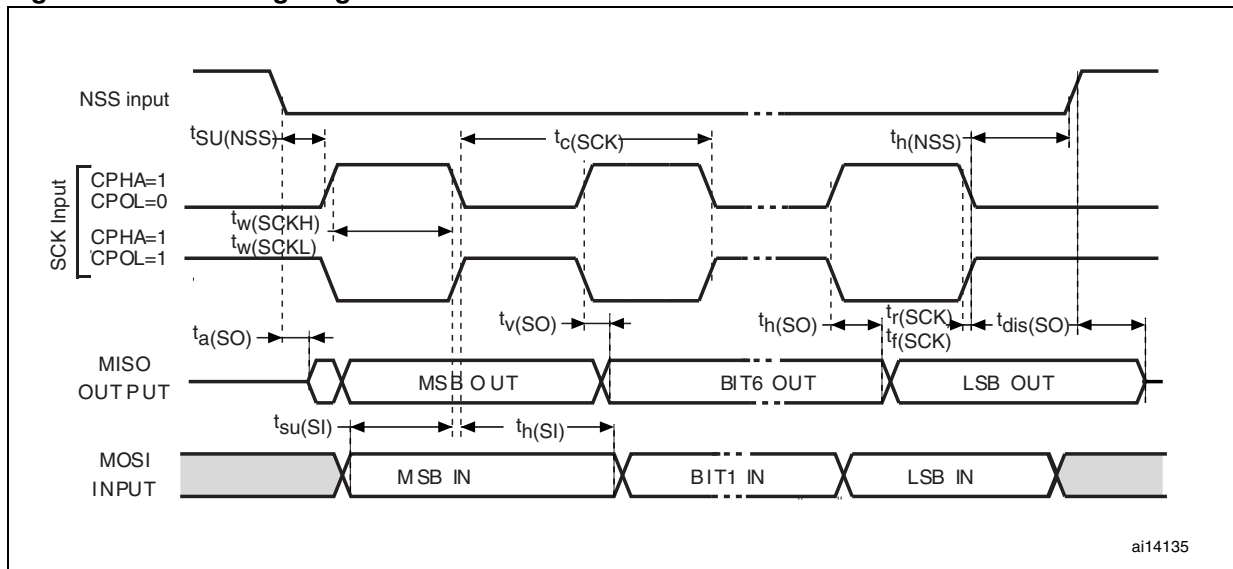
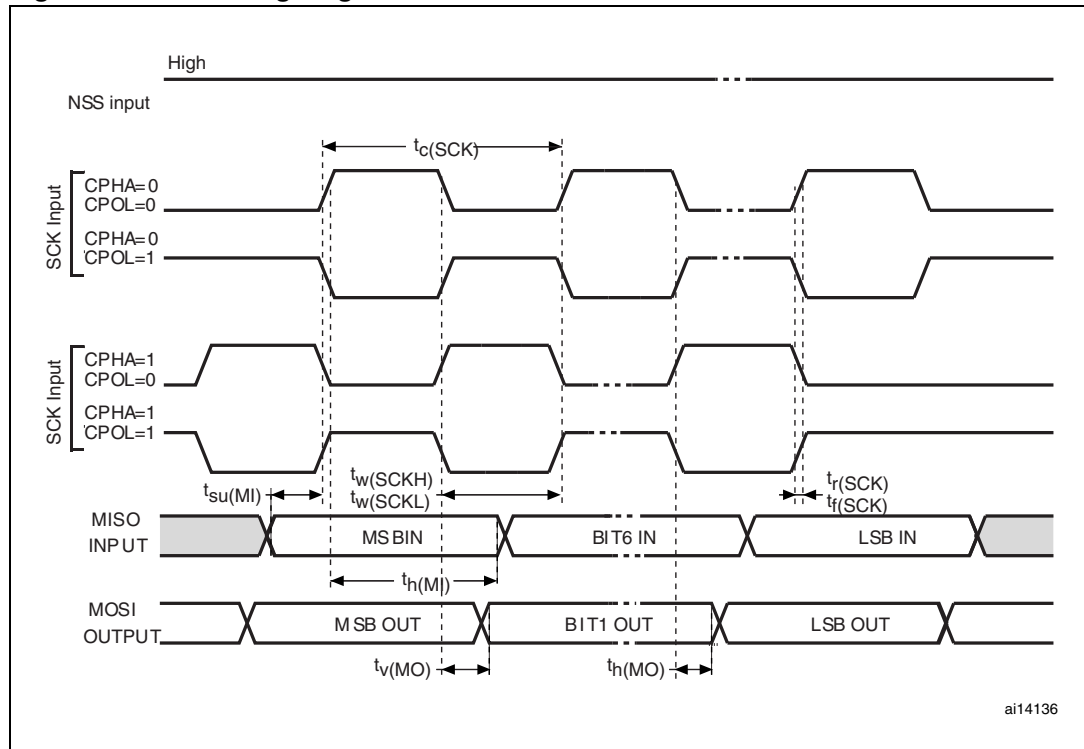

Figure 27. SPI timing diagram - slave mode and CPHA = 1⁽¹⁾



1. Measurement points are done at CMOS levels: 0.3V_{DD} and 0.7V_{DD}.

Figure 28. SPI timing diagram - master mode⁽¹⁾



1. Measurement points are done at CMOS levels: $0.3V_{DD}$ and $0.7V_{DD}$.

USB characteristics

The USB interface is USB-IF certified (full speed).

Table 58. USB startup time

Symbol	Parameter	Max	Unit
$t_{STARTUP}^{(1)}$	USB transceiver startup time	1	μs

1. Guaranteed by design, not tested in production.

Table 59. USB DC electrical characteristics

Symbol	Parameter	Conditions	Min. ⁽¹⁾	Max. ⁽¹⁾	Unit
Input levels					
V _{DD}	USB operating voltage		3.0	3.6	V
V _{DI} ⁽²⁾	Differential input sensitivity	I(USBDP, USBDM)	0.2	-	V
V _{CM} ⁽²⁾	Differential common mode range	Includes V _{DI} range	0.8	2.5	
V _{SE} ⁽²⁾	Single ended receiver threshold		1.3	2.0	
Output levels					
V _{OL} ⁽³⁾	Static output level low	R _L of 1.5 kΩ to 3.6 V ⁽⁴⁾	-	0.3	V
V _{OH} ⁽³⁾	Static output level high	R _L of 15 kΩ to V _{SS} ⁽⁴⁾	2.8	3.6	

1. All the voltages are measured from the local ground potential.
2. Guaranteed by characterization, not tested in production.
3. Tested in production.
4. R_L is the load connected on the USB drivers.

Figure 29. USB timings: definition of data signal rise and fall time

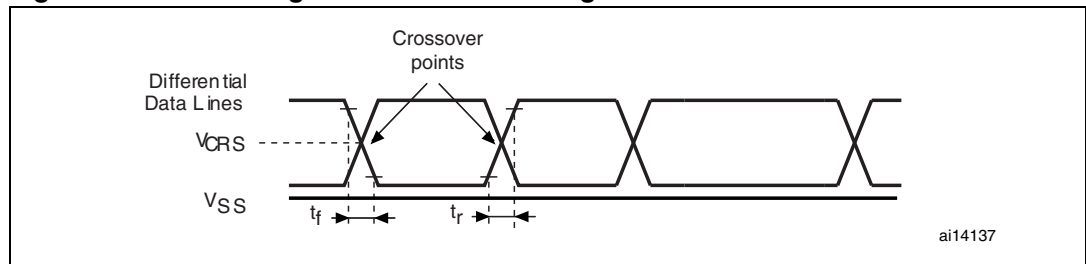

Table 60. USB: full speed electrical characteristics

Driver characteristics ⁽¹⁾					
Symbol	Parameter	Conditions	Min	Max	Unit
t _r	Rise time ⁽²⁾	C _L = 50 pF	4	20	ns
t _f	Fall Time ⁽²⁾	C _L = 50 pF	4	20	ns
t _{rfm}	Rise/ fall time matching	t _r /t _f	90	110	%
V _{CRS}	Output signal crossover voltage		1.3	2.0	V

1. Guaranteed by design, not tested in production.
2. Measured from 10% to 90% of the data signal. For more detailed informations, please refer to USB Specification - Chapter 7 (version 2.0).

6.3.17 12-bit ADC characteristics

Unless otherwise specified, the parameters given in [Table 62](#) are guaranteed by design.

Table 61. ADC clock frequency

Symbol	Parameter	Conditions		Min	Max	Unit
f _{ADC}	ADC clock frequency	Voltage range 1 & 2	2.4 V ≤ V _{DDA} ≤ 3.6 V	V _{REF+} = V _{DDA}	16	MHz
				V _{REF+} < V _{DDA} V _{REF+} > 2.4 V	8	
			1.8 V ≤ V _{DDA} ≤ 2.4 V	V _{REF+} < V _{DDA} V _{REF+} ≤ 2.4 V	4	
				V _{REF+} = V _{DDA}	8	
		Voltage range 3	V _{REF+} < V _{DDA}	4		
				4		

Table 62. ADC characteristics

Symbol	Parameter	Conditions	Min	Typ	Max	Unit
V _{DDA}	Power supply		1.8	-	3.6	V
V _{REF+}	Positive reference voltage	2.4 V ≤ V _{DDA} ≤ 3.6 V V _{REF+} must be below or equal to V _{DDA}	1.8 ⁽¹⁾	-	V _{DDA}	
V _{REF-}	Negative reference voltage		-	V _{SSA}	-	
I _{VDDA}	Current on the V _{DDA} input pin		-	1000	1450	μA
I _{VREF} ⁽²⁾	Current on the V _{REF} input pin	Peak	-	400	700	
		Average	-		450	
V _{AIN}	Conversion voltage range ⁽³⁾		0 ⁽⁴⁾	-	V _{REF+}	V
f _s	12-bit sampling rate	Direct channels	0.03	-	1	Msps
		Multiplexed channels	0.03	-	0.76	
	10-bit sampling rate	Direct channels	0.03	-	1.07	Msps
		Multiplexed channels	0.03	-	0.8	
	8-bit sampling rate	Direct channels	0.03	-	1.23	Msps
		Multiplexed channels	0.03	-	0.89	
	6-bit sampling rate	Direct channels	0.03	-	1.54	Msps
		Multiplexed channels	0.03	-	1	

Table 62. ADC characteristics (continued)

Symbol	Parameter	Conditions	Min	Typ	Max	Unit
t _S	Sampling time	Direct channels 2.4 V ≤ V _{DDA} ≤ 3.6 V	0.25 ⁽⁵⁾	-	-	μs
		Multiplexed channels 2.4 V ≤ V _{DDA} ≤ 3.6 V	0.56 ⁽⁵⁾	-	-	
		Direct channels 1.8 V ≤ V _{DDA} ≤ 2.4 V	0.56 ⁽⁵⁾	-	-	
		Multiplexed channels 1.8 V ≤ V _{DDA} ≤ 2.4 V	1 ⁽⁵⁾	-	-	
				4	-	384
t _{CONV}	Total conversion time (including sampling time)	f _{ADC} = 16 MHz	1	-	24.75	μs
			4 to 384 (sampling phase) +12 (successive approximation)			1/f _{ADC}
C _{ADC}	Internal sample and hold capacitor	Direct channels	-	16	-	pF
		Multiplexed channels	-		-	
f _{TRIG}	External trigger frequency Regular sequencer	12-bit conversions	-	-	Tconv+1	1/f _{ADC}
		6/8/10-bit conversions	-	-	Tconv	1/f _{ADC}
f _{TRIG}	External trigger frequency Injected sequencer	12-bit conversions	-	-	Tconv+2	1/f _{ADC}
		6/8/10-bit conversions	-	-	Tconv+1	1/f _{ADC}
R _{AIN} ⁽⁶⁾	External input impedance		-	-	50	kΩ
			-	-	0.5	
t _{lat}	Injection trigger conversion latency	f _{ADC} = 16 MHz	219	-	281	ns
			3.5	-	4.5	1/f _{ADC}
t _{latr}	Regular trigger conversion latency	f _{ADC} = 16 MHz	156	-	219	ns
			2.5	-	3.5	1/f _{ADC}
t _{STAB}	Power-up time		-	-	3.5	μs

- The Vref+ input can be grounded if neither the ADC nor the DAC are used (this allows to shut down an external voltage reference).
- The current consumption through VREF is composed of two parameters:
 - one constant (max 300 μA)
 - one variable (max 400 μA), only during sampling time + 2 first conversion pulses
 So, peak consumption is 300+400 = 700 μA and average consumption is 300 + [(4 sampling + 2) /16] x 400 = 450 μA at 1Msps
- V_{REF+} can be internally connected to V_{DDA} and V_{REF-} can be internally connected to V_{SSA}, depending on the package. Refer to [Section 4: Pin descriptions](#) for further details.
- V_{SSA} or V_{REF-} must be tied to ground.
- Minimum sampling and conversion time is reached for maximum Rext = 0.5 kΩ.
- For 1 Msps, maximum Rext is 0.5 kΩ.

Table 63. ADC accuracy⁽¹⁾⁽²⁾

Symbol	Parameter	Test conditions	Min ⁽³⁾	Typ	Max ⁽³⁾	Unit
ET	Total unadjusted error	$2.4\text{ V} \leq V_{DDA} \leq 3.6\text{ V}$ $2.4\text{ V} \leq V_{REF+} \leq 3.6\text{ V}$ $f_{ADC} = 8\text{ MHz}$, $R_{AIN} = 50\ \Omega$ $T_A = -40\text{ to }105\text{ }^\circ\text{C}$	-	2	4	LSB
EO	Offset error		-	1	2	
EG	Gain error		-	1.5	3.5	
ED	Differential linearity error		-	1	2	
EL	Integral linearity error		-	1.7	3	
ENOB	Effective number of bits	$2.4\text{ V} \leq V_{DDA} \leq 3.6\text{ V}$ $V_{DDA} = V_{REF+}$ $f_{ADC} = 16\text{ MHz}$, $R_{AIN} = 50\ \Omega$ $T_A = -40\text{ to }105\text{ }^\circ\text{C}$ $1\text{ kHz} \leq F_{input} \leq 100\text{ kHz}$	9.2	10	-	bits
SINAD	Signal-to-noise and distortion ratio		57.5	62	-	dB
SNR	Signal-to-noise ratio		57.5	62	-	
THD	Total harmonic distortion		-74	-75	-	
ET	Total unadjusted error		-	4	6.5	
EO	Offset error	$2.4\text{ V} \leq V_{DDA} \leq 3.6\text{ V}$ $1.8\text{ V} \leq V_{REF+} \leq 2.4\text{ V}$ $f_{ADC} = 4\text{ MHz}$, $R_{AIN} = 50\ \Omega$ $T_A = -40\text{ to }105\text{ }^\circ\text{C}$	-	2	4	LSB
EG	Gain error		-	4	6	
ED	Differential linearity error		-	1	2	
EL	Integral linearity error		-	1.5	3	
ET	Total unadjusted error		-	2	3	
EO	Offset error	$1.8\text{ V} \leq V_{DDA} \leq 2.4\text{ V}$ $1.8\text{ V} \leq V_{REF+} \leq 2.4\text{ V}$ $f_{ADC} = 4\text{ MHz}$, $R_{AIN} = 50\ \Omega$ $T_A = -40\text{ to }105\text{ }^\circ\text{C}$	-	1	1.5	LSB
EG	Gain error		-	1.5	2	
ED	Differential linearity error		-	1	2	
EL	Integral linearity error		-	1	1.5	
ET	Total unadjusted error		-	2	3	

1. ADC DC accuracy values are measured after internal calibration.
2. ADC accuracy vs. negative injection current: Injecting a negative current on any analog input pins should be avoided as this significantly reduces the accuracy of the conversion being performed on another analog input. It is recommended to add a Schottky diode (pin to ground) to analog pins which may potentially inject negative currents. Any positive injection current within the limits specified for $I_{INJ(PIN)}$ and $\Sigma I_{INJ(PIN)}$ in [Section 6.3.12](#) does not affect the ADC accuracy.
3. Based on characterization, not tested in production.

Figure 30. ADC accuracy characteristics

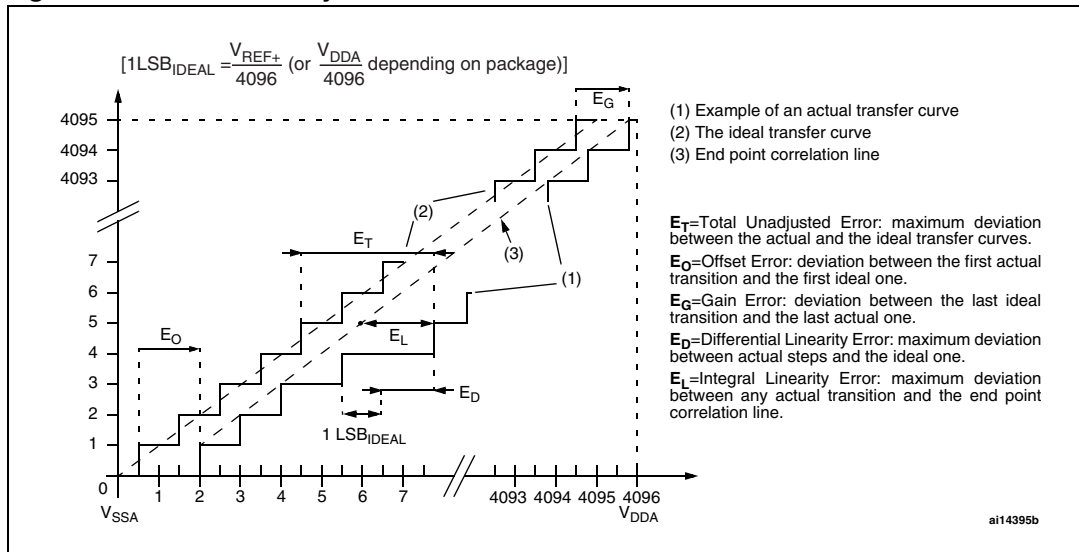
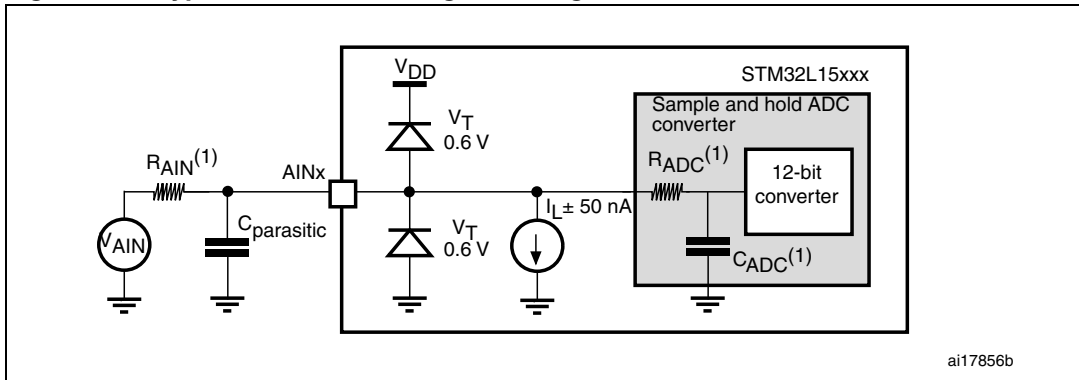

Figure 31. Typical connection diagram using the ADC



1. Refer to [Table 62](#) for the values of R_{AIN} , R_{ADC} and C_{ADC} .
2. $C_{parasitic}$ represents the capacitance of the PCB (dependent on soldering and PCB layout quality) plus the pad capacitance (roughly 7 pF). A high $C_{parasitic}$ value will downgrade conversion accuracy. To remedy this, f_{ADC} should be reduced.

Figure 32. Maximum dynamic current consumption on V_{REF+} supply pin during ADC conversion

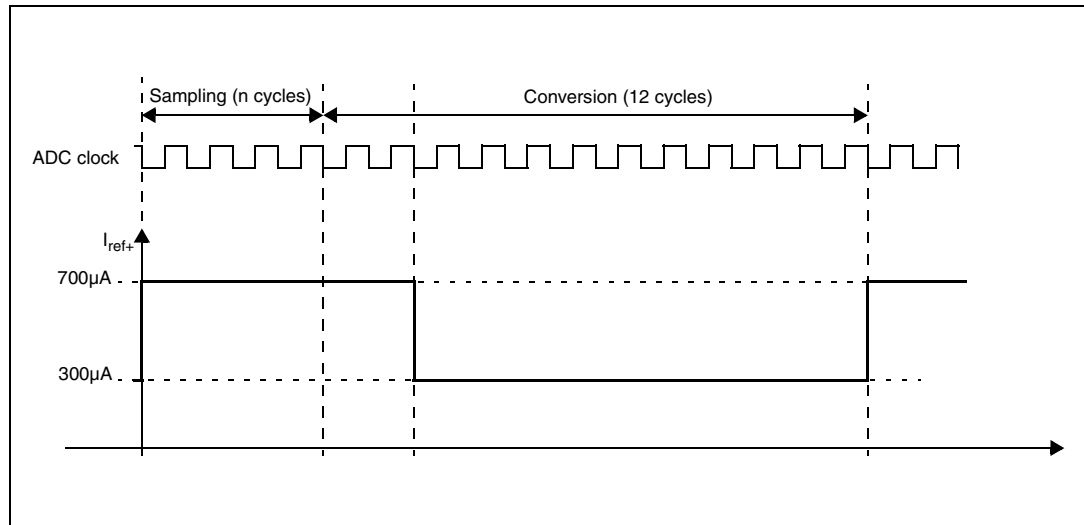

Table 64. R_{AIN} max for f_{ADC} = 16 MHz⁽¹⁾

Ts (cycles)	Ts (µs)	R _{AIN} max (kΩ)			
		Multiplexed channels		Direct channels	
		2.4 V < V _{DDA} < 3.6 V	1.8 V < V _{DDA} < 2.4 V	2.4 V < V _{DDA} < 3.3 V	1.8 V < V _{DDA} < 2.4 V
4	0.25	Not allowed	Not allowed	0.7	Not allowed
9	0.5625	0.8	Not allowed	2.0	1.0
16	1	2.0	0.8	4.0	3.0
24	1.5	3.0	1.8	6.0	4.5
48	3	6.8	4.0	15.0	10.0
96	6	15.0	10.0	30.0	20.0
192	12	32.0	25.0	50.0	40.0
384	24	50.0	50.0	50.0	50.0

1. Guaranteed by design, not tested in production.

General PCB design guidelines

Power supply decoupling should be performed as shown in [Figure 33](#) or [Figure 34](#), depending on whether V_{REF+} is connected to V_{DDA} or not. The 10 nF capacitors should be ceramic (good quality). They should be placed as close as possible to the chip.

Figure 33. Power supply and reference decoupling (V_{REF+} not connected to V_{DDA})

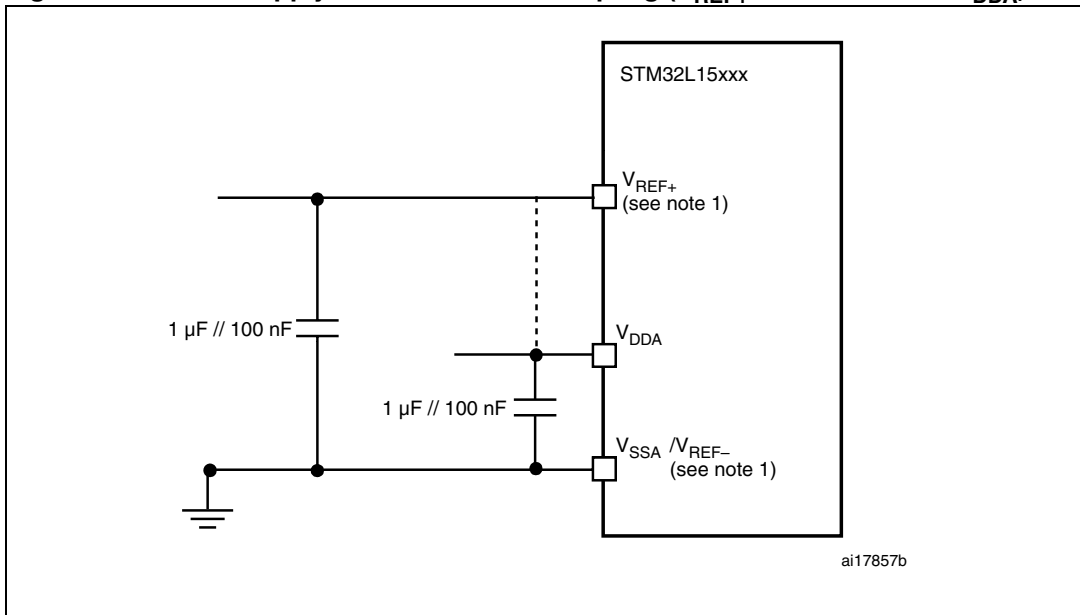

1. V_{REF+} and V_{REF-} inputs are available only on 100-pin packages.

Figure 34. Power supply and reference decoupling (V_{REF+} connected to V_{DDA})

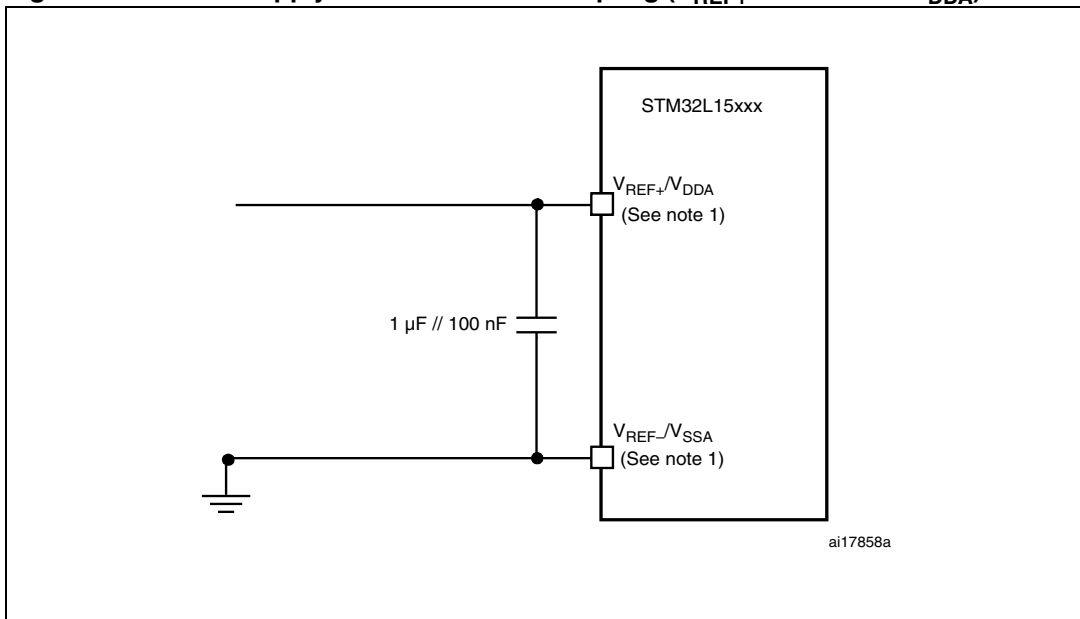

1. V_{REF+} and V_{REF-} inputs are available only on 100-pin packages.

6.3.18 DAC electrical specifications

Data guaranteed by design, not tested in production, unless otherwise specified.

Table 65. DAC characteristics

Symbol	Parameter	Conditions	Min	Typ	Max	Unit
V_{DDA}	Analog supply voltage		1.8	-	3.6	V
V_{REF+}	Reference supply voltage	V_{REF+} must always be below V_{DDA}	1.8	-	3.6	
V_{REF-}	Lower reference voltage		V_{SSA}			
$I_{DDVREF+}^{(1)}$	Current consumption on V_{REF+} supply $V_{REF+} = 3.3$ V	No load, middle code (0x800)	-	130	220	μ A
		No load, worst code (0x000)	-	220	350	
$I_{DDA}^{(1)}$	Current consumption on V_{DDA} supply $V_{DDA} = 3.3$ V	No load, middle code (0x800)	-	210	320	
		No load, worst code (0xF1C)	-	320	520	
$R_L^{(2)}$	Resistive load	DAC output buffer ON	5	-	-	k Ω
$C_L^{(2)}$	Capacitive load		-	-	50	pF
R_O	Output impedance	DAC output buffer OFF	6	8	10	k Ω
V_{DAC_OUT}	Voltage on DAC_OUT output	DAC output buffer ON	0.2	-	$V_{DDA} - 0.2$	V
		DAC output buffer OFF	0.5	-	$V_{REF+} - 1\text{LSB}$	mV
$DNL^{(1)}$	Differential non linearity ⁽³⁾	$C_L \leq 50$ pF, $R_L \geq 5$ k Ω DAC output buffer ON	-	1.5	3	LSB
		No R_{LOAD} , $C_L \leq 50$ pF DAC output buffer OFF	-	1.5	3	
$INL^{(1)}$	Integral non linearity ⁽⁴⁾	$C_L \leq 50$ pF, $R_L \geq 5$ k Ω DAC output buffer ON	-	2	4	
		No R_{LOAD} , $C_L \leq 50$ pF DAC output buffer OFF	-	2	4	
Offset ⁽¹⁾	Offset error at code 0x800 ⁽⁵⁾	$C_L \leq 50$ pF, $R_L \geq 5$ k Ω DAC output buffer ON	-	± 10	± 25	
		No R_{LOAD} , $C_L \leq 50$ pF DAC output buffer OFF	-	± 5	± 8	
Offset1 ⁽¹⁾	Offset error at code 0x001 ⁽⁶⁾	No R_{LOAD} , $C_L \leq 50$ pF DAC output buffer OFF	-	± 1.5	± 5	

Table 65. DAC characteristics (continued)

Symbol	Parameter	Conditions	Min	Typ	Max	Unit
dOffset/dT ⁽¹⁾	Offset error temperature coefficient (code 0x800)	V _{DDA} = 3.3V V _{REF+} = 3.0V T _A = 0 to 50 °C DAC output buffer OFF	-20	-10	0	μV/°C
		V _{DDA} = 3.3V V _{REF+} = 3.0V T _A = 0 to 50 °C DAC output buffer ON	0	20	50	
Gain ⁽¹⁾	Gain error ⁽⁷⁾	C _L ≤ 50 pF, R _L ≥ 5 kΩ DAC output buffer ON	-	+0.1 / -0.2%	+0.2 / -0.5%	%
		No R _{LOAD} , C _L ≤ 50 pF DAC output buffer OFF	-	+0 / -0.2%	+0 / -0.4%	
dGain/dT ⁽¹⁾	Gain error temperature coefficient	V _{DDA} = 3.3V V _{REF+} = 3.0V T _A = 0 to 50 °C DAC output buffer OFF	-10	-2	0	μV/°C
		V _{DDA} = 3.3V V _{REF+} = 3.0V T _A = 0 to 50 °C DAC output buffer ON	-40	-8	0	
TUE ⁽¹⁾	Total unadjusted error	C _L ≤ 50 pF, R _L ≥ 5 kΩ DAC output buffer ON	-	12	30	LSB
		No R _{LOAD} , C _L ≤ 50 pF DAC output buffer OFF	-	8	12	
t _{SETTLING}	Settling time (full scale: for a 12-bit code transition between the lowest and the highest input codes till DAC_OUT reaches final value ±1LSB)	C _L ≤ 50 pF, R _L ≥ 5 kΩ	-	7	12	μs
Update rate	Max frequency for a correct DAC_OUT change (95% of final value) with 1 LSB variation in the input code	C _L ≤ 50 pF, R _L ≥ 5 kΩ	-		1	MspS
t _{WAKEUP}	Wakeup time from off state (setting the ENx bit in the DAC Control register) ⁽⁸⁾	C _L ≤ 50 pF, R _L ≥ 5 kΩ	-	9	15	μs
PSRR+	V _{DDA} supply rejection ratio (static DC measurement)	C _L ≤ 50 pF, R _L ≥ 5 kΩ	-	-60	-35	dB

1. Data based on characterization results.
2. Connected between DAC_OUT and V_{SSA}.
3. Difference between two consecutive codes - 1 LSB.
4. Difference between measured value at Code i and the value at Code i on a line drawn between Code 0 and last Code 4095.

5. Difference between the value measured at Code (0x800) and the ideal value = $V_{REF+}/2$.
6. Difference between the value measured at Code (0x001) and the ideal value.
7. Difference between ideal slope of the transfer function and measured slope computed from code 0x000 and 0xFF when buffer is OFF, and from code giving 0.2 V and $(V_{DDA} - 0.2)$ V when buffer is ON.
8. In buffered mode, the output can overshoot above the final value for low input code (starting from min value).

Figure 35. 12-bit buffered /non-buffered DAC

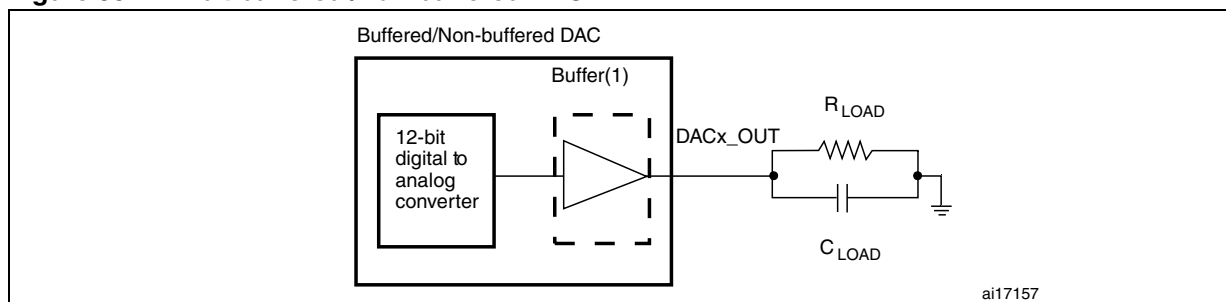

1. The DAC integrates an output buffer that can be used to reduce the output impedance and to drive external loads directly without the use of an external operational amplifier. The buffer can be bypassed by configuring the BOFFx bit in the DAC_CR register.

6.3.19 Operational amplifier characteristics

Table 66. Operational amplifier characteristics

Symbol	Parameter		Condition ⁽¹⁾	Min ⁽²⁾	Typ	Max ⁽²⁾	Unit
CMIR	Common mode input range			0	-	V_{DD}	
V_{I_OFFSET}	Input offset voltage	Maximum calibration range		-	-	± 15	mV
		After offset calibration		-	-	± 1.5	
ΔV_{I_OFFSET}	Input offset voltage drift	Normal mode		-	-	± 40	$\mu V/^{\circ}C$
		Low power mode		-	-	± 80	
I_{IB}	Input current bias	Dedicated input	75 °C	-	-	1	nA
		General purpose input		-	-	10	
I_{LOAD}	Drive current	Normal mode		-	-	500	μA
		Low power mode		-	-	100	
I_{DD}	Consumption	Normal mode	No load, quiescent mode	-	100	220	μA
		Low power mode		-	30	60	
CMRR	Common mode rejection ration	Normal mode		-	-85	-	dB
		Low power mode		-	-90	-	
PSRR	Power supply rejection ratio	Normal mode	DC	-	-85	-	dB
		Low power mode		-	-90	-	

Table 66. Operational amplifier characteristics (continued)

Symbol	Parameter		Condition ⁽¹⁾	Min ⁽²⁾	Typ	Max ⁽²⁾	Unit
GBW	Bandwidth	Normal mode	$V_{DD} > 2.4\text{ V}$	400	1000	3000	kHz
		Low power mode		150	300	800	
		Normal mode	$V_{DD} < 2.4\text{ V}$	200	500	2200	
		Low power mode		70	150	800	
SR	Slew rate	Normal mode	$V_{DD} > 2.4\text{ V}$ (between 0.1 V and $V_{DD} - 0.1\text{ V}$)	-	700	-	V/ms
		Low power mode	$V_{DD} > 2.4\text{ V}$	-	100	-	
		Normal mode	$V_{DD} < 2.4\text{ V}$	-	300	-	
		Low power mode		-	50	-	
AO	Open loop gain	Normal mode		55	100	-	dB
		Low power mode		65	110	-	
R _{LOAD}	Resistive load	Normal mode	$V_{DD} < 2.4\text{ V}$	4	-	-	kΩ
		Low power mode		20	-	-	
C _{LOAD}	Capacitive load			-	-	50	pF
V _{OH} SAT	High saturation voltage	Normal mode	$I_{LOAD} = \text{max or}$ $R_{LOAD} = \text{min}$	$V_{DD} - 100$	-	-	mV
		Low power mode		$V_{DD} - 50$	-	-	
V _{OL} SAT	Low saturation voltage	Normal mode		-	-	100	
		low power mode		-	-	50	
φ _m	Phase margin			-	60	-	°
GM	Gain margin			-	-12	-	dB
t _{OFFTRIM}	Offset trim time: during calibration, minimum time needed between two steps to have 1 mV accuracy			-	1	-	ms
t _{WAKEUP}	Wakeup time	Normal mode	$C_{LOAD} \leq 50\text{ pf,}$ $R_{LOAD} \geq 4\text{ k}\Omega$	-	10	-	μs
		Low power mode	$C_{LOAD} \leq 50\text{ pf,}$ $R_{LOAD} \geq 20\text{ k}\Omega$	-	30	-	

1. Operating conditions are limited to junction temperature (0 °C to 105 °C) when V_{DD} is below 2 V. Otherwise, the operating temperature range is 105 °C to -40 °C.
2. Data based on characterization results, not tested in production.

6.3.20 Temperature sensor characteristics

Table 67. TS characteristics

Symbol	Parameter	Min	Typ	Max	Unit
$T_L^{(1)}$	V_{SENSE} linearity with temperature	-	± 1	± 2	$^{\circ}\text{C}$
Avg_Slope ⁽¹⁾	Average slope	TBD	1.66	TBD	mV/ $^{\circ}\text{C}$
V_{110}	Voltage at 110 $^{\circ}\text{C} \pm 5^{\circ}\text{C}^{(2)}$	612	626.8	641.5	mV
$I_{DDA(TEMP)}^{(3)}$	Current consumption	-	3.4	6	μA
$t_{START}^{(3)}$	Startup time	-	-	10	μs
$T_{S_temp}^{(4)(3)}$	ADC sampling time when reading the temperature	-	5	10	

1. Guaranteed by characterization, not tested in production.
2. Measured at $V_{DD} = 3 \text{ V} \pm 10 \text{ mV}$. V_{110} ADC conversion result is stored in the TS_Factory_CONV_V110 byte.
3. Guaranteed by design, not tested in production.
4. Shortest sampling time can be determined in the application by multiple iterations.

6.3.21 Comparator

Table 68. Comparator 1 characteristics

Symbol	Parameter	Conditions	Min ⁽¹⁾	Typ	Max ⁽¹⁾	Unit
V_{DDA}	Analog supply voltage		1.65		3.6	V
R_{400K}	R_{400K} value		-	400	-	k Ω
R_{10K}	R_{10K} value		-	10	-	
V_{IN}	Comparator 1 input voltage range		0.6	-	V_{DDA}	V
t_{START}	Comparator startup time		-	7	10	μs
t_d	Propagation delay ⁽²⁾		-	3	10	
Voffset	Comparator offset		-	± 3	± 10	mV
$d_{Voffset}/dt$	Comparator offset variation in worst voltage stress conditions	$V_{DDA} = 3.6 \text{ V}$ $V_{IN+} = 0 \text{ V}$ $V_{IN-} = V_{REFINT}$ $T_A = 25 \text{ }^{\circ}\text{C}$	0	1.5	10	mV/1000 h
I_{COMP1}	Current consumption ⁽³⁾		-	160	260	nA

1. Based on characterization, not tested in production.
2. The delay is characterized for 100 mV input step with 10 mV overdrive on the inverting input, the non-inverting input set to the reference.
3. Comparator consumption only. Internal reference voltage not included.

Table 69. Comparator 2 characteristics

Symbol	Parameter	Conditions	Min	Typ	Max ⁽¹⁾	Unit
V _{DDA}	Analog supply voltage		1.65	-	3.6	V
V _{IN}	Comparator 2 input voltage range		0	-	V _{DDA}	V
t _{START}	Comparator startup time	Fast mode	-	15	20	μs
		Slow mode	-	20	25	
t _{d slow}	Propagation delay ⁽²⁾ in slow mode	1.65 V ≤ V _{DDA} ≤ 2.7 V	-	1.8	3.5	
		2.7 V ≤ V _{DDA} ≤ 3.6 V	-	2.5	6	
t _{d fast}	Propagation delay ⁽²⁾ in fast mode	1.65 V ≤ V _{DDA} ≤ 2.7 V	-	0.8	2	
		2.7 V ≤ V _{DDA} ≤ 3.6 V	-	1.2	4	
V _{offset}	Comparator offset error		-	±4	±20	mV
dThreshold/dt	Threshold voltage temperature coefficient	V _{DDA} = 3.3V T _A = 0 to 50 °C V ₋ = V _{REF+} , 3/4 V _{REF+} , 1/2 V _{REF+} , 1/4 V _{REF+}	-	15	30	ppm/°C
I _{COMP2}	Current consumption ⁽³⁾	Fast mode	-	3.5	5	μA
		Slow mode	-	0.5	2	

1. Based on characterization, not tested in production.
2. The delay is characterized for 100 mV input step with 10 mV overdrive on the inverting input, the non-inverting input set to the reference.
3. Comparator consumption only. Internal reference voltage (necessary for comparator operation) is not included.

6.3.22 LCD controller (STM32L152xD only)

The STM32L152xD embeds a built-in step-up converter to provide a constant LCD reference voltage independently from the V_{DD} voltage. An external capacitor C_{ext} must be connected to the V_{LCD} pin to decouple this converter.

Table 70. LCD controller characteristics

Symbol	Parameter	Min	Typ	Max	Unit
V_{LCD}	LCD external voltage	-	-	3.6	V
V_{LCD0}	LCD internal reference voltage 0	-	2.6	-	
V_{LCD1}	LCD internal reference voltage 1	-	2.73	-	
V_{LCD2}	LCD internal reference voltage 2	-	2.86	-	
V_{LCD3}	LCD internal reference voltage 3	-	2.98	-	
V_{LCD4}	LCD internal reference voltage 4	-	3.12	-	
V_{LCD5}	LCD internal reference voltage 5	-	3.26	-	
V_{LCD6}	LCD internal reference voltage 6	-	3.4	-	
V_{LCD7}	LCD internal reference voltage 7	-	3.55	-	
C_{ext}	V_{LCD} external capacitance	0.1		2	μF
$I_{LCD}^{(1)}$	Supply current at $V_{DD} = 2.2\text{ V}$	-	3.3	-	μA
	Supply current at $V_{DD} = 3.0\text{ V}$	-	3.1	-	
$R_{Htot}^{(2)}$	Low drive resistive network overall value	5.28	6.6	7.92	$\text{M}\Omega$
$R_L^{(2)}$	High drive resistive network total value	192	240	288	$\text{k}\Omega$
V_{44}	Segment/Common highest level voltage	-	-	V_{LCD}	V
V_{34}	Segment/Common 3/4 level voltage	-	$3/4 V_{LCD}$	-	V
V_{23}	Segment/Common 2/3 level voltage	-	$2/3 V_{LCD}$	-	
V_{12}	Segment/Common 1/2 level voltage	-	$1/2 V_{LCD}$	-	
V_{13}	Segment/Common 1/3 level voltage	-	$1/3 V_{LCD}$	-	
V_{14}	Segment/Common 1/4 level voltage	-	$1/4 V_{LCD}$	-	
V_0	Segment/Common lowest level voltage	0	-	-	
$\Delta V_{xx}^{(3)}$	Segment/Common level voltage error $T_A = -40\text{ to }85\text{ }^\circ\text{C}$	-	-	± 50	mV

1. LCD enabled with 3 V internal step-up active, 1/8 duty, 1/4 bias, division ratio= 64, all pixels active, no LCD connected.
2. Guaranteed by design, not tested in production.
3. Based on characterization, not tested in production.

7 Package characteristics

7.1 Package mechanical data

In order to meet environmental requirements, ST offers these devices in different grades of ECOPACK[®] packages, depending on their level of environmental compliance. ECOPACK[®] specifications, grade definitions and product status are available at: www.st.com. ECOPACK[®] is an ST trademark.

Figure 36. LQFP144, 20 x 20 mm, 144-pin low-profile quad flat package outline

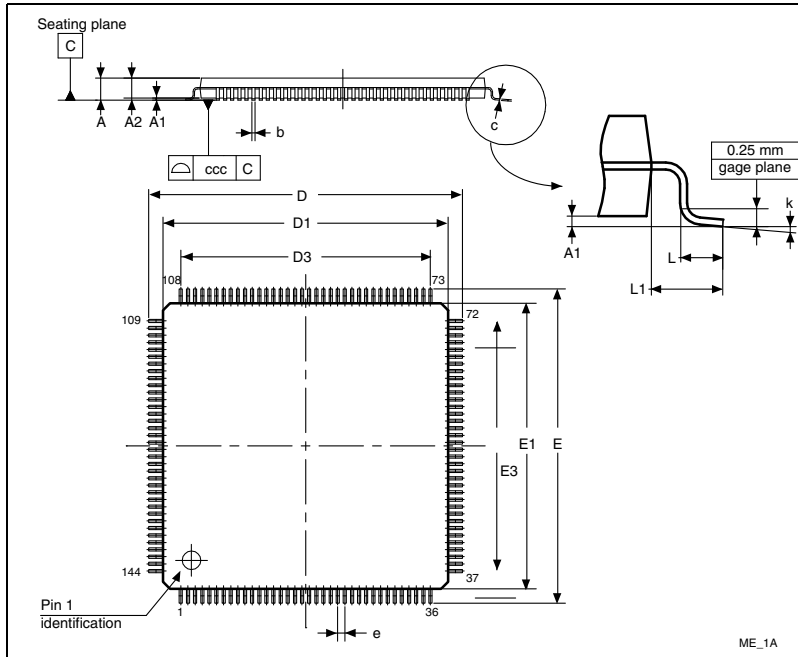
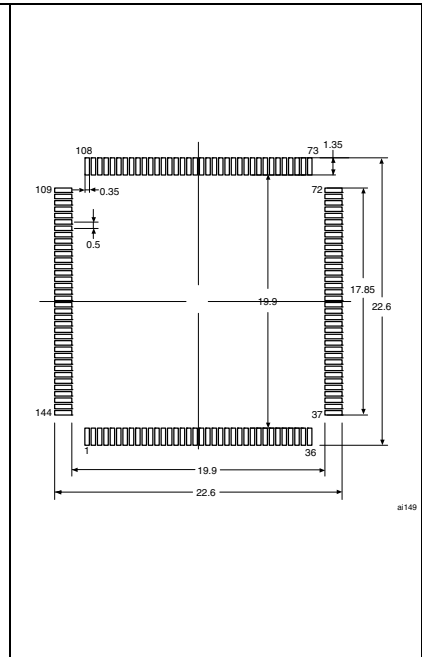

Figure 37. Recommended footprint



1. Drawing is not to scale. Dimensions are in millimeters.

Table 71. LQFP144, 20 x 20 mm, 144-pin low-profile quad flat package mechanical data

Symbol	millimeters			inches ⁽¹⁾		
	Min	Typ	Max	Min	Typ	Max
A			1.60			0.063
A1	0.05		0.15	0.002		0.0059
A2	1.35	1.40	1.45	0.0531	0.0551	0.0571
b	0.17	0.22	0.27	0.0067	0.0087	0.0106
c	0.09		0.20	0.0035		0.0079
D	21.80	22.00	22.20	0.8583	0.8661	0.874
D1	19.80	20.00	20.20	0.7795	0.7874	0.7953
D3		17.50			0.689	
E	21.80	22.00	22.20	0.8583	0.8661	0.874
E1	19.80	20.00	20.20	0.7795	0.7874	0.7953
E3		17.50			0.689	
e		0.50			0.0197	
L	0.45	0.60	0.75	0.0177	0.0236	0.0295
L1		1.00			0.0394	
k	0°	3.5°	7°	0°	3.5°	7°
ccc		0.08			0.0031	

1. Values in inches are converted from mm and rounded to 4 decimal digits.

Figure 38. LQFP100, 14 x 14 mm, 100-pin low-profile quad flat package outline

Figure 39. Recommended footprint

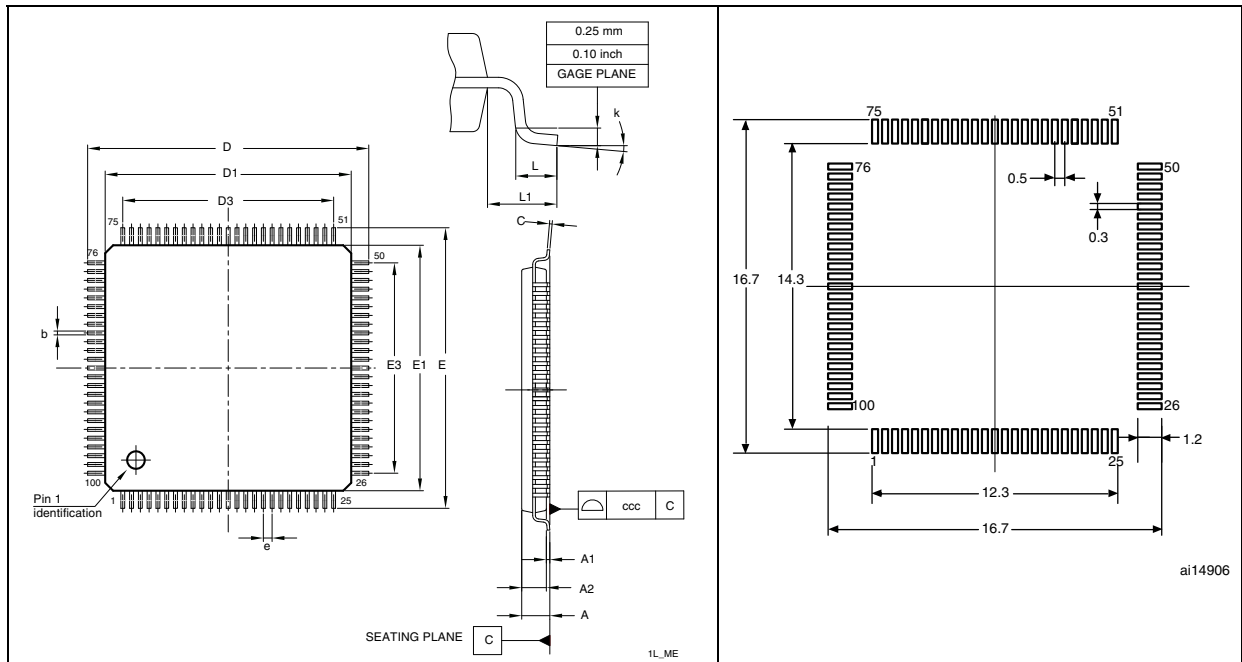

1. Drawing is not to scale. Dimensions are in millimeters.

Table 72. LQFP100, 14 x 14 mm, 100-pin low-profile quad flat package mechanical data

Symbol	millimeters			inches ⁽¹⁾		
	Min	Typ	Max	Min	Typ	Max
A			1.6			0.063
A1	0.05		0.15	0.002		0.0059
A2	1.35	1.4	1.45	0.0531	0.0551	0.0571
b	0.17	0.22	0.27	0.0067	0.0087	0.0106
c	0.09		0.2	0.0035		0.0079
D	15.8	16	16.2	0.622	0.6299	0.6378
D1	13.8	14	14.2	0.5433	0.5512	0.5591
D3		12			0.4724	
E	15.8	16	16.2	0.622	0.6299	0.6378
E1	13.8	14	14.2	0.5433	0.5512	0.5591
E3		12			0.4724	
e		0.5			0.0197	
L	0.45	0.6	0.75	0.0177	0.0236	0.0295
L1		1			0.0394	
k	0.0°	3.5°	7.0°	0.0°	3.5°	7.0°
ccc		0.08			0.0031	

1. Values in inches are converted from mm and rounded to 4 decimal digits.

Figure 40. LQFP64, 10 x 10 mm, 64-pin low-profile quad flat package outline

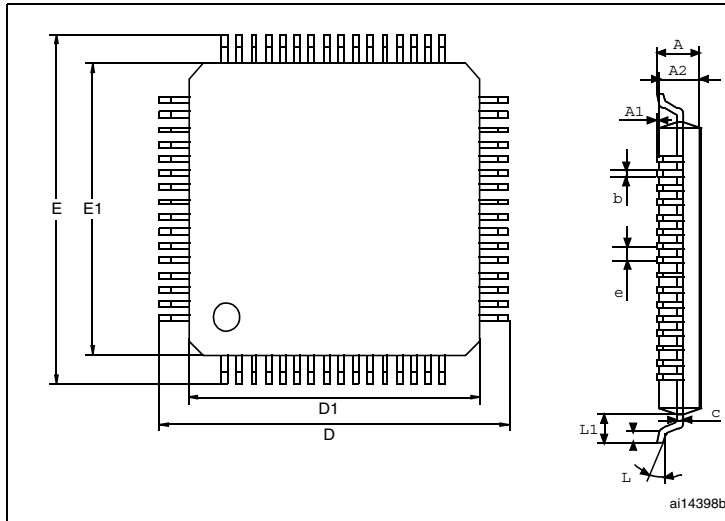
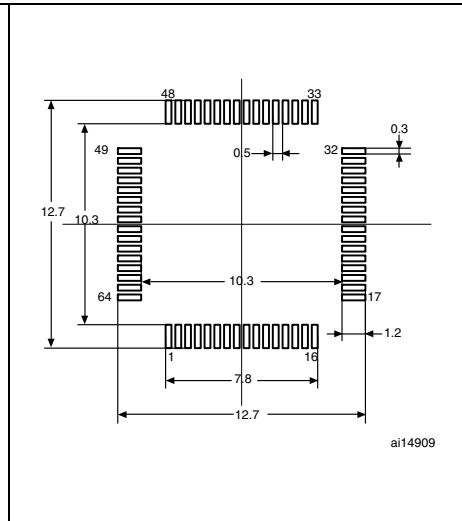

Figure 41. Recommended footprint



1. Drawing is not to scale. Dimensions are in millimeters.

Table 73. LQFP64, 10 x 10 mm 64-pin low-profile quad flat package mechanical data

Symbol	millimeters			inches ⁽¹⁾		
	Min	Typ	Max	Min	Typ	Max
A			1.60			0.0630
A1	0.05		0.15	0.0020		0.0059
A2	1.35	1.40	1.45	0.0531	0.0551	0.0571
b	0.17	0.22	0.27	0.0067	0.0087	0.0106
c	0.09		0.20	0.0035		0.0079
D		12.00			0.4724	
D1		10.00			0.3937	
E		12.00			0.4724	
E1		10.00			0.3937	
e		0.50			0.0197	
θ	0°	3.5°	7°	0°	3.5°	7°
L	0.45	0.60	0.75	0.0177	0.0236	0.0295
L1		1.00			0.0394	
N	Number of pins					
	64					

1. Values in inches are converted from mm and rounded to 4 decimal digits.

Figure 42. UFBGA132, 7 x 7 mm, 132-ball ultra thin, fine-pitch ball grid array package outline

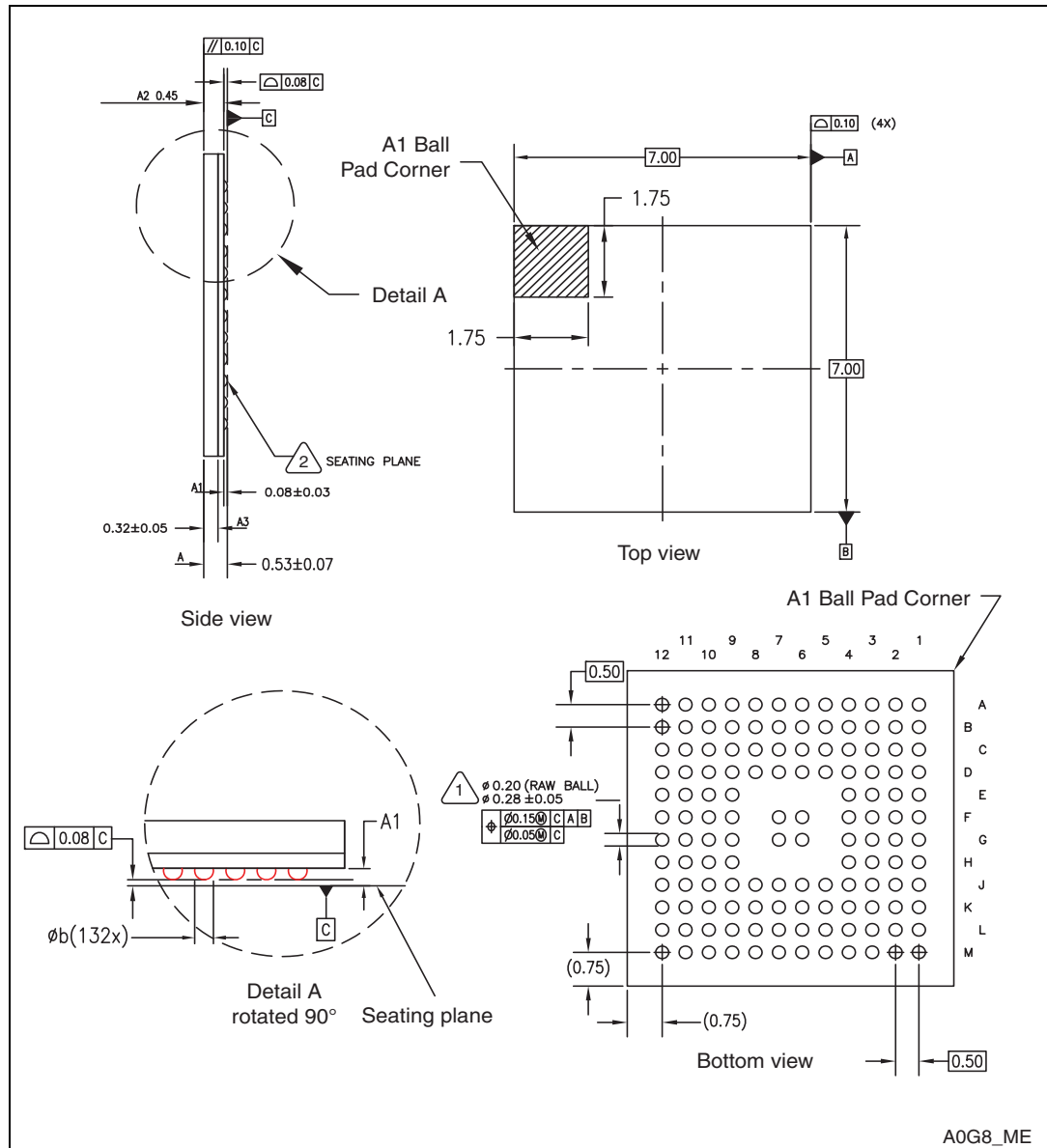

1. Primary datum C and seating plane are defined by the spherical crowns of the solder balls.
2. Dimension is measured at the maximum solder ball diameter, parallel to primary datum C.

Table 74. UFBGA132 package mechanical data

Symbol	millimeters			inches ⁽¹⁾		
	Min	Typ	Max	Min	Typ	Max
A	0.46	0.53	0.60	0.0181	0.0209	0.0236
A1	0.05	0.08	0.11	0.0020	0.0032	0.0043
A2	0.40	0.45	0.50	0.0157	0.0177	0.0197
b	0.17	0.28	0.33	0.0067	0.0110	0.0130

1. Values in inches are converted from mm and rounded to 4 decimal digits.

Figure 43. WLCSP64, 0.400 mm pitch wafer level chip size package outline

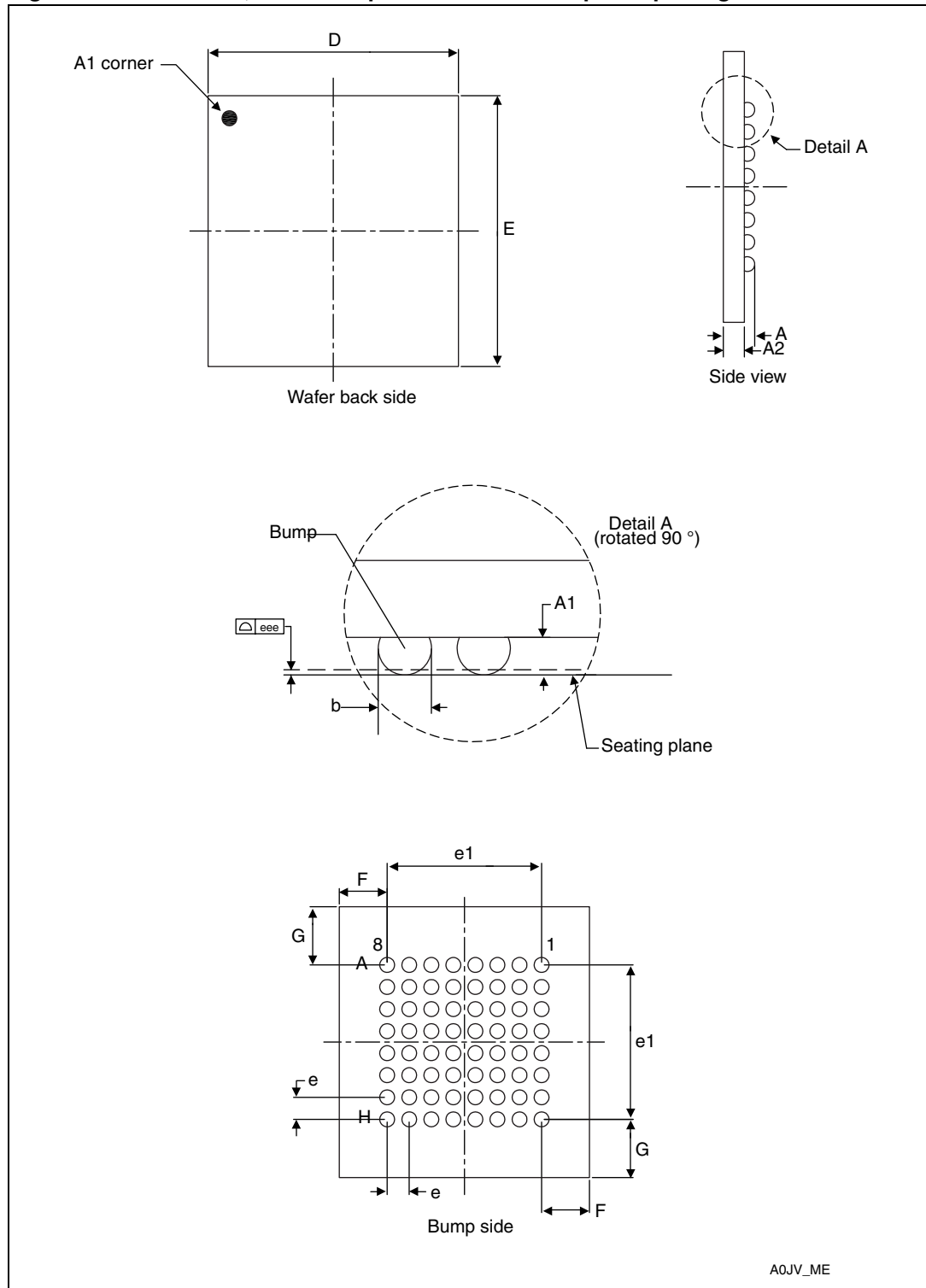

Table 75. WLCSP64, 0.400 mm pitch wafer level chip size package mechanical data

Symbol	millimeters			inches ⁽¹⁾		
	Min	Typ	Max	Min	Typ	Max
A	0.520	0.570	0.620	0.0205	0.0224	0.0244
A1	0.170	0.190	0.210	0.0067	0.0075	0.0083
A2	0.350	0.380	0.410	0.0138	0.0150	0.0161
b	0.240	0.270	0.300	0.0094	0.0106	0.0118
D	4.519	4.539	4.559	0.1779	0.1787	0.1795
E	4.891	4.911	4.931	0.1926	0.1933	0.1941
e		0.400			0.0157	
e1		2.800			0.1102	
F		0.870			0.0343	
G		1.056			0.0416	
eee		0.050			0.0020	

1. Values in inches are converted from mm and rounded to 4 decimal digits.

7.2 Thermal characteristics

The maximum chip-junction temperature, $T_J \text{ max}$, in degrees Celsius, may be calculated using the following equation:

$$T_J \text{ max} = T_A \text{ max} + (P_D \text{ max} \times \Theta_{JA})$$

Where:

- $T_A \text{ max}$ is the maximum ambient temperature in °C,
- Θ_{JA} is the package junction-to-ambient thermal resistance, in °C/W,
- $P_D \text{ max}$ is the sum of $P_{INT \text{ max}}$ and $P_{I/O \text{ max}}$ ($P_D \text{ max} = P_{INT \text{ max}} + P_{I/O \text{ max}}$),
- $P_{INT \text{ max}}$ is the product of I_{DD} and V_{DD} , expressed in Watts. This is the maximum chip internal power.

$P_{I/O \text{ max}}$ represents the maximum power dissipation on output pins where:

$$P_{I/O \text{ max}} = \Sigma (V_{OL} \times I_{OL}) + \Sigma ((V_{DD} - V_{OH}) \times I_{OH}),$$

taking into account the actual V_{OL} / I_{OL} and V_{OH} / I_{OH} of the I/Os at low and high level in the application.

Table 76. Thermal characteristics

Symbol	Parameter	Value	Unit
Θ_{JA}	Thermal resistance junction-ambient LQFP144 - 20 x 20 mm / 0.5 mm pitch	40	°C/W
	Thermal resistance junction-ambient BGA132 - 7 x 7 mm	60	
	Thermal resistance junction-ambient LQFP100 - 14 x 14 mm / 0.5 mm pitch	43	
	Thermal resistance junction-ambient LQFP64 - 10 x 10 mm / 0.5 mm pitch	46	
	Thermal resistance junction-ambient WLCSP64 - 0.400 mm pitch	46	

7.2.1 Reference document

JESD51-2 Integrated Circuits Thermal Test Method Environment Conditions - Natural Convection (Still Air). Available from www.jedec.org.

8 Ordering information scheme

Table 77. STM32L15xxD ordering information scheme

Example:	STM32	L	151	R	C	T	6	D	xxx
Device family STM32 = ARM-based 32-bit microcontroller									
Product type L = Low power									
Device subfamily 151: Devices without LCD 152: Devices with LCD									
Pin count R = 64 pins V = 100 pins Z = 144 pins Q = 132 pins									
Flash memory size D = 384 Kbytes of Flash memory									
Package H = BGA T = LQFP Y = WLCSP									
Temperature range 6 = Industrial temperature range, -40 to 85 °C									
Options No character = V _{DD} range: 1.8 to 3.6 V and BOR enabled D = V _{DD} range: 1.65 to 3.6 V and BOR disabled									
Packing TR = tape and reel No character = tray or tube									

For a list of available options (speed, package, etc.) or for further information on any aspect of this device, please contact your nearest ST sales office.

9 Revision history

Table 78. Document revision history

Date	Revision	Changes
03-Oct-2011	1	Initial release.
03-Feb-2012	2	<p>Status of the document changed (datasheet instead of preliminary data).</p> <p>Updated low power features on page 1.</p> <p>Removed references to devices with 256 KB of Flash memory. GPIOF replaced with GIOPH.</p> <p>Added SDIO in Table 2: Ultralow power STM32L15xxD device features and peripheral counts on page 10 and in Table 9: Alternate function input/output on page 38 (FSMC/SDIO instead of FSMC).</p> <p>Table 2: Ultralow power STM32L15xxD device features and peripheral counts: replaced STM32L15xWx with STM32L15xQx.</p> <p>Figure 1: Ultralow power STM32L15xxD block diagram: updated legend.</p> <p>Modified Section 3.4: Clock management on page 17.</p> <p>Table 6: STM32L15xQD BGA132 ballout: replaced STM32L15xWC/D with STM32L15xQD.</p> <p>Figure 3, Figure 4, Figure 5: updated titles.</p> <p>Table 8: STM32L15xxD pin definitions: updated title, updated pins PF0, PF1, PH2, PF12, PF13, PF14, PF15, PG0, PG1, PG12, PG15, PD0, and PD1.</p> <p>Table 9: Alternate function input/output: Modified alternate function for PA13 and PA14; removed EVENT OUT for PH2.</p> <p>Figure 6: Memory map: removed the text “APB memory space”.</p> <p>Modified Figure 9: Power supply scheme on page 49.</p> <p>Modified Table 14: Functionalities depending on the operating power supply range on page 52.</p> <p>Table 18: Current consumption in Run mode, code with data processing running from RAM: added footnote 3.</p> <p>Table 19: Current consumption in Sleep mode: updated condition for f_{HSE}; added footnote 3.</p> <p>Table 23: Typical and maximum current consumptions in Standby mode: modified max values.</p> <p>Table 59: USB DC electrical characteristics: removed two footnotes.</p> <p>Modified Table 35: Flash memory and data EEPROM characteristics on page 76.</p> <p>Table 76: Thermal characteristics: updated “TBDs” with values.</p> <p>Modified tables in Section 6.3.4: Supply current characteristics on page 55.</p>

Table 78. Document revision history (continued)

Date	Revision	Changes
18-Apr-2012	3	<p>Added WLCSP64 package.</p> <p><i>Section 3.1: Low power modes</i>: changed '128 kHz' to '131 kHz' in section "Low power run mode".</p> <p><i>Section 3.17.1: General-purpose timers (TIM2, TIM3, TIM4, TIM5, TIM9, TIM10 and TIM11)</i>: changed 'six' to 'seven' synchronizable general-purpose timers.</p> <p><i>Table 8: STM32L15xxD pin definitions on page 32</i>: updated name of reference manual in footnote 5.</p> <p>I2C updated: footnote 3. from <i>Table 55</i></p> <p>Note about I2C clock updated: footnote 2. from <i>Table 55</i> modified.</p> <p>Note [non-robust] updated: footnote 2. from <i>Table 63</i> modified.</p> <p>GPIOs high current capability updated: <i>Section 3.6: GPIOs (general-purpose inputs/outputs)</i> 'except for analog inputs' was removed.</p>
15-Jun-2012	4	<p>Changed maximum number of touch sensing channels to 34, and updated <i>Table 2: Ultralow power STM32L15xxD device features and peripheral counts</i>.</p> <p>Updated <i>Section 3.11: ADC (analog-to-digital converter)</i> to add <i>Section 3.11.1: Temperature sensor</i> and <i>Section 3.11.2: Internal voltage reference (VREFINT)</i>.</p> <p>Removed caution note below <i>Figure 9: Power supply scheme</i>.</p> <p>Added note below <i>Table 6: STM32L15xQD BGA132 ballout</i>.</p> <p>Modified <i>Table 7: STM32L15xRD WLCSP64 ballout</i> to match top view.</p> <p>Changed FSMC_LBAR into FSMC_NADV, and I2C1_SMBAL into I2C1_SMBA in <i>Table 8: STM32L15xxD pin definitions</i>.</p> <p>Modified PB10/11/12 for AFIO4 alternate function, and replaced LBAR by NADV for AFIO12 in <i>Table 9: Alternate function input/output</i>.</p> <p>Updated <i>Table 22: Typical and maximum current consumptions in Stop mode</i> and added <i>Note 6</i>. Updated <i>Table 23: Typical and maximum current consumptions in Standby mode</i>. Updated t_{WSTOP} in <i>Table 24: Typical and maximum timings in Low power modes</i>.</p> <p>Updated <i>Table 25: Peripheral current consumption</i>.</p> <p>Updated <i>Table 57: SPI characteristics</i>, added <i>Note 1</i> and <i>Note 3</i>, and applied <i>Note 2</i> to $t_r(SCK)$, $t_f(SCK)$, $t_w(SCKH)$, $t_w(SCKL)$, $t_{su}(MI)$, $t_{su}(SI)$, $t_h(MI)$, and $t_h(SI)$.</p> <p>Updated I_{DD} maximum value in <i>Table 35: Flash memory and data EEPROM characteristics</i>.</p>

Please Read Carefully:

Information in this document is provided solely in connection with ST products. STMicroelectronics NV and its subsidiaries ("ST") reserve the right to make changes, corrections, modifications or improvements, to this document, and the products and services described herein at any time, without notice.

All ST products are sold pursuant to ST's terms and conditions of sale.

Purchasers are solely responsible for the choice, selection and use of the ST products and services described herein, and ST assumes no liability whatsoever relating to the choice, selection or use of the ST products and services described herein.

No license, express or implied, by estoppel or otherwise, to any intellectual property rights is granted under this document. If any part of this document refers to any third party products or services it shall not be deemed a license grant by ST for the use of such third party products or services, or any intellectual property contained therein or considered as a warranty covering the use in any manner whatsoever of such third party products or services or any intellectual property contained therein.

UNLESS OTHERWISE SET FORTH IN ST'S TERMS AND CONDITIONS OF SALE ST DISCLAIMS ANY EXPRESS OR IMPLIED WARRANTY WITH RESPECT TO THE USE AND/OR SALE OF ST PRODUCTS INCLUDING WITHOUT LIMITATION IMPLIED WARRANTIES OF MERCHANTABILITY, FITNESS FOR A PARTICULAR PURPOSE (AND THEIR EQUIVALENTS UNDER THE LAWS OF ANY JURISDICTION), OR INFRINGEMENT OF ANY PATENT, COPYRIGHT OR OTHER INTELLECTUAL PROPERTY RIGHT.

UNLESS EXPRESSLY APPROVED IN WRITING BY TWO AUTHORIZED ST REPRESENTATIVES, ST PRODUCTS ARE NOT RECOMMENDED, AUTHORIZED OR WARRANTED FOR USE IN MILITARY, AIR CRAFT, SPACE, LIFE SAVING, OR LIFE SUSTAINING APPLICATIONS, NOR IN PRODUCTS OR SYSTEMS WHERE FAILURE OR MALFUNCTION MAY RESULT IN PERSONAL INJURY, DEATH, OR SEVERE PROPERTY OR ENVIRONMENTAL DAMAGE. ST PRODUCTS WHICH ARE NOT SPECIFIED AS "AUTOMOTIVE GRADE" MAY ONLY BE USED IN AUTOMOTIVE APPLICATIONS AT USER'S OWN RISK.

Resale of ST products with provisions different from the statements and/or technical features set forth in this document shall immediately void any warranty granted by ST for the ST product or service described herein and shall not create or extend in any manner whatsoever, any liability of ST.

ST and the ST logo are trademarks or registered trademarks of ST in various countries.

Information in this document supersedes and replaces all information previously supplied.

The ST logo is a registered trademark of STMicroelectronics. All other names are the property of their respective owners.

© 2012 STMicroelectronics - All rights reserved

STMicroelectronics group of companies

Australia - Belgium - Brazil - Canada - China - Czech Republic - Finland - France - Germany - Hong Kong - India - Israel - Italy - Japan - Malaysia - Malta - Morocco - Philippines - Singapore - Spain - Sweden - Switzerland - United Kingdom - United States of America

www.st.com