



STM8L162R8 STM8L162M8

8-bit ultralow power MCU, 64 KB Flash, 2 KB data EEPROM, RTC, AES, LCD, timers, USARTs, I2C, SPIs, ADC, DAC, COMPs

Datasheet – production data

Features

- Operating conditions
 - Operating power supply: 1.65 to 3.6 V (without BOR), 1.8 to 3.6 V (with BOR)
 - Temperature range: – 40 to 85 or 125 °C
- Low power features
 - 5 low power modes: Wait, Low power run, Low power wait, Active-halt with RTC, Halt
 - Ultralow leakage per I/O: 50 nA
 - Fast wakeup from Halt: 5 µs
- Advanced STM8 core
 - Harvard architecture and 3-stage pipeline
 - Max freq: 16 MHz, 16 CISC MIPS peak
 - Up to 40 external interrupt sources
- Reset and supply management
 - Low power, ultrasafe BOR reset with 5 selectable thresholds
 - Ultralow power POR/PDR
 - Programmable voltage detector (PVD)
- Clock management
 - 32 kHz and 1-16 MHz crystal oscillators
 - Internal 16 MHz factory-trimmed RC
 - Internal 38 kHz low consumption RC
 - Clock security system
- Low power RTC
 - BCD calendar with alarm interrupt
 - Digital calibration with +/- 0.5ppm accuracy
 - LSE security system
 - Auto-wakeup from Halt w/ periodic interrupt
 - Advanced anti-tamper detection
- LCD: 8x40 or 4x44 w/ step-up converter
- Memories
 - 64 KB of Flash program memory plus 2 KB of data EEPROM with ECC and RWW
 - Flexible write/read protection modes
 - 4 KB of RAM
- DMA
 - 4 channels supporting ADC, AES, DACs, SPIs, I²C, USARTs, timers
 - 1 channel for memory-to-memory
- AES encryption hardware accelerator
- 2x12-bit DAC (dual mode) with output buffer
- 12-bit ADC up to 1 Msps/28 channels
 - Temp. sensor and internal ref. voltage
- 2 ultralow power comparators (COMP)
 - 1 with fixed threshold and 1 rail to rail
 - Wakeup capability
- Timers
 - Three 16-bit timers with 2 channels (IC, OC, PWM), quadrature encoder
 - One 16-bit advanced control timer with 3 channels, supporting motor control
 - One 8-bit timer with 7-bit prescaler
 - 1 Window and 1 independent watchdog
 - Beeper timer with 1, 2 or 4 kHz frequencies
- Communication interfaces
 - Two synchronous serial interface (SPI)
 - Fast I²C 400 kHz SMBus and PMBus
 - Three USARTs (ISO 7816 interface + IrDA)
- Up to 67 I/Os, all mappable on interrupt vectors
- Up to 16 capacitive sensing channels supporting touchkey, proximity, linear touch and rotary touch sensors
- Development support
 - Fast on-chip programming and non-intrusive debugging with SWIM
 - Bootloader using USART
- 96-bit unique ID

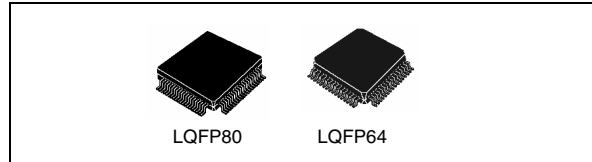

Contents

1	Introduction	8
2	Description	8
2.1	STM8L Ultralow power 8-bit family benefits	9
2.2	Device overview	10
2.3	Ultralow power continuum	11
3	Functional overview	12
3.1	Low power modes	13
3.2	Central processing unit STM8	14
3.2.1	Advanced STM8 Core	14
3.2.2	Interrupt controller	14
3.3	Reset and supply management	15
3.3.1	Power supply scheme	15
3.3.2	Power supply supervisor	15
3.3.3	Voltage regulator	16
3.4	Clock management	16
3.5	Low power real-time clock	17
3.6	LCD (Liquid crystal display)	18
3.7	Memories	18
3.8	DMA	18
3.9	Analog-to-digital converter	19
3.10	Digital-to-analog converter	19
3.11	Ultralow power comparators	19
3.12	System configuration controller and routing interface	20
3.13	Touch sensing	20
3.14	AES	20
3.15	Timers	20
3.15.1	16-bit advanced control timer (TIM1)	21
3.15.2	16-bit general purpose timers (TIM2, TIM3, TIM5)	21
3.15.3	8-bit basic timer (TIM4)	21
3.16	Watchdog timers	22

3.16.1	Window watchdog timer	22
3.16.2	Independent watchdog timer	22
3.17	Beeper	22
3.18	Communication interfaces	22
3.18.1	SPI	22
3.18.2	I ² C	22
3.18.3	USART	23
3.19	Infrared (IR) interface	23
3.20	Development support	23
4	Pin description	24
5	Memory and register map	33
5.1	Memory mapping	33
5.2	Register map	34
6	Interrupt vector mapping	55
7	Option bytes	57
8	Unique ID	60
9	Electrical parameters	61
9.1	Parameter conditions	61
9.1.1	Minimum and maximum values	61
9.1.2	Typical values	61
9.1.3	Typical curves	61
9.1.4	Loading capacitor	61
9.1.5	Pin input voltage	62
9.2	Absolute maximum ratings	62
9.3	Operating conditions	64
9.3.1	General operating conditions	64
9.3.2	Embedded reset and power control block characteristics	65
9.3.3	Supply current characteristics	68
9.3.4	Clock and timing characteristics	83
9.3.5	Memory characteristics	88
9.3.6	I/O current injection characteristics	90

9.3.7	I/O port pin characteristics	90
9.3.8	Communication interfaces	97
9.3.9	LCD controller	101
9.3.10	Embedded reference voltage	103
9.3.11	Temperature sensor	104
9.3.12	Comparator characteristics	104
9.3.13	12-bit DAC characteristics	107
9.3.14	12-bit ADC1 characteristics	109
9.3.15	EMC characteristics	114
9.4	Thermal characteristics	116
10	Package characteristics	117
10.1	Package mechanical data	117
11	Ordering information scheme	120
12	Revision history	121

List of tables

Table 1.	High density STM8L162x low power device features and peripheral counts	10
Table 2.	Timer feature comparison	21
Table 3.	Legend/abbreviation	25
Table 4.	STM8L162x pin description	25
Table 5.	Flash and RAM boundary addresses	34
Table 6.	Factory conversion registers	34
Table 7.	I/O port hardware register map	34
Table 8.	General hardware register map	36
Table 9.	CPU/SWIM/debug module/interrupt controller registers	53
Table 10.	Interrupt mapping	55
Table 11.	Option byte addresses	57
Table 12.	Option byte description	58
Table 13.	Unique ID registers (96 bits)	60
Table 14.	Voltage characteristics	62
Table 15.	Current characteristics	63
Table 16.	Thermal characteristics	63
Table 17.	General operating conditions	64
Table 18.	Embedded reset and power control block characteristics	65
Table 19.	Total current consumption in Run mode	68
Table 20.	Total current consumption in Wait mode	71
Table 21.	Total current consumption and timing in Low power run mode at VDD = 1.65 V to 3.6 V	74
Table 22.	Total current consumption in Low power wait mode at VDD = 1.65 V to 3.6 V	76
Table 23.	Total current consumption and timing in Active-halt mode at VDD = 1.65 V to 3.6 V	78
Table 24.	Typical current consumption in Active-halt mode, RTC clocked by LSE external crystal	80
Table 25.	Total current consumption and timing in Halt mode at VDD = 1.65 to 3.6 V	81
Table 26.	Peripheral current consumption	82
Table 27.	Current consumption under external reset	83
Table 28.	HSE external clock characteristics	83
Table 29.	LSE external clock characteristics	84
Table 30.	HSE oscillator characteristics	84
Table 31.	LSE oscillator characteristics	85
Table 32.	HSI oscillator characteristics	86
Table 33.	LSI oscillator characteristics	87
Table 34.	RAM and hardware registers	88
Table 35.	Flash program and data EEPROM memory	89
Table 36.	I/O current injection susceptibility	90
Table 37.	I/O static characteristics	91
Table 38.	Output driving current (high sink ports)	93
Table 39.	Output driving current (true open drain ports)	94
Table 40.	Output driving current (PA0 with high sink LED driver capability)	94
Table 41.	NRST pin characteristics	95
Table 42.	SPI1 characteristics	97
Table 43.	I2C characteristics	100
Table 44.	LCD characteristics	101
Table 45.	Reference voltage characteristics	103
Table 46.	TS characteristics	104

Table 47.	Comparator 1 characteristics	105
Table 48.	Comparator 2 characteristics	105
Table 49.	DAC characteristics	107
Table 50.	DAC accuracy	108
Table 51.	DAC output on PB4-PB5-PB6	108
Table 52.	ADC1 characteristics	109
Table 53.	ADC1 accuracy with VDDA = 3.3 V to 2.5 V	111
Table 54.	ADC1 accuracy with VDDA = 2.4 V to 3.6 V	111
Table 55.	ADC1 accuracy with VDDA = VREF+ = 1.8 V to 2.4 V	111
Table 56.	EMS data	114
Table 57.	EMI data	115
Table 58.	ESD absolute maximum ratings	115
Table 59.	Electrical sensitivities	115
Table 60.	Thermal characteristics	116
Table 61.	80-pin low profile quad flat package mechanical data	118
Table 62.	LQFP64 – 10 x 10 mm, 64-pin low-profile quad flat package mechanical data	119
Table 63.	Ordering information scheme	120
Table 64.	Document revision history	121

List of figures

Figure 1.	High density STM8L162xx device block diagram	12
Figure 2.	Clock tree diagram	17
Figure 3.	STM8L162M8 80-pin package pinout	24
Figure 4.	STM8L162R8 64-pin pinout	24
Figure 5.	Memory map	33
Figure 6.	Pin loading conditions	61
Figure 7.	Pin input voltage	62
Figure 8.	Power supply thresholds	67
Figure 9.	Typical $I_{DD(RUN)}$ from RAM vs. V_{DD} (HSI clock source), $f_{CPU} = 16$ MHz	70
Figure 10.	Typical $I_{DD(RUN)}$ from Flash vs. V_{DD} (HSI clock source), $f_{CPU} = 16$ MHz	70
Figure 11.	Typical $I_{DD(Wait)}$ from RAM vs. V_{DD} (HSI clock source), $f_{CPU} = 16$ MHz	73
Figure 12.	Typical $I_{DD(Wait)}$ from Flash (HSI clock source), $f_{CPU} = 16$ MHz	73
Figure 13.	Typical $I_{DD(LPR)}$ vs. V_{DD} (LSI clock source), all peripherals OFF	75
Figure 14.	Typical $I_{DD(LPW)}$ vs. V_{DD} (LSI clock source), all peripherals OFF	77
Figure 15.	Typical $I_{DD(AH)}$ vs. V_{DD} (LSI clock source)	80
Figure 16.	Typical $I_{DD(Halt)}$ vs. V_{DD} (internal reference voltage OFF)	81
Figure 17.	HSE oscillator circuit diagram	85
Figure 18.	LSE oscillator circuit diagram	86
Figure 19.	Typical HSI frequency vs. V_{DD}	87
Figure 20.	Typical LSI clock source frequency vs. V_{DD}	88
Figure 21.	Typical V_{IL} and V_{IH} vs. V_{DD} (standard I/Os)	92
Figure 22.	Typical V_{IL} and V_{IH} vs. V_{DD} (true open drain I/Os)	92
Figure 23.	Typical pull-up resistance R_{PU} vs. V_{DD} with $V_{IN} = V_{SS}$	92
Figure 24.	Typical pull-up current I_{pu} vs. V_{DD} with $V_{IN} = V_{SS}$	93
Figure 25.	Typical V_{OL} @ $V_{DD} = 3.0$ V (high sink ports)	94
Figure 26.	Typical V_{OL} @ $V_{DD} = 1.8$ V (high sink ports)	94
Figure 27.	Typical V_{OL} @ $V_{DD} = 3.0$ V (true open drain ports)	94
Figure 28.	Typical V_{OL} @ $V_{DD} = 1.8$ V (true open drain ports)	94
Figure 29.	Typical $V_{DD} - V_{OH}$ @ $V_{DD} = 3.0$ V (high sink ports)	95
Figure 30.	Typical $V_{DD} - V_{OH}$ @ $V_{DD} = 1.8$ V (high sink ports)	95
Figure 31.	Typical NRST pull-up resistance R_{PU} vs. V_{DD}	96
Figure 32.	Typical NRST pull-up current I_{pu} vs. V_{DD}	96
Figure 33.	Recommended NRST pin configuration	96
Figure 34.	SPI1 timing diagram - slave mode and $CPHA = 0$	98
Figure 35.	SPI1 timing diagram - slave mode and $CPHA = 1$	98
Figure 36.	SPI1 timing diagram - master mode	99
Figure 37.	Typical application with I2C bus and timing diagram	101
Figure 38.	ADC1 accuracy characteristics	112
Figure 39.	Typical connection diagram using the ADC	112
Figure 40.	Power supply and reference decoupling (V_{REF+} not connected to V_{DDA})	113
Figure 41.	Power supply and reference decoupling (V_{REF+} connected to V_{DDA})	113
Figure 42.	80-pin low profile quad flat package (14 x 14 mm)	118
Figure 43.	LQFP64 – 10 x 10 mm, 64 pin low-profile quad flat package outline	119
Figure 44.	Recommended footprint ⁽¹⁾	119

1 Introduction

This document describes the features, pinout, mechanical data and ordering information for the high density STM8L162R8 and STM8L162M8 devices. For further details on the STMicroelectronics Ultralow power family please refer to [Section 2.3: Ultralow power continuum on page 11](#).

For detailed information on device operation and registers, refer to the reference manual (RM0031).

For information on to the Flash program memory and data EEPROM, refer to the programming manual (PM0054).

For information on the debug module and SWIM (single wire interface module), refer to the STM8 SWIM communication protocol and debug module user manual (UM0470).

For information on the STM8 core, refer to the STM8 CPU programming manual (PM0044).

2 Description

The high density STM8L162xx Ultralow power devices feature an enhanced STM8 CPU core providing increased processing power (up to 16 MIPS at 16 MHz) while maintaining the advantages of a CISC architecture with improved code density, a 24-bit linear addressing space and an optimized architecture for low power operations.

The family includes an integrated debug module with a hardware interface (SWIM) which allows non-intrusive in-application debugging and ultrafast Flash programming.

All high density STM8L162xx microcontrollers feature embedded data EEPROM and low power low-voltage single-supply program Flash memory.

The devices incorporate an extensive range of enhanced I/Os and peripherals, a 12-bit ADC, two DACs, two comparators, a real-time clock, AES, 8x40 or 4x44-segment LCD, four 16-bit timers, one 8-bit timer, as well as standard communication interfaces such as two SPIs, an I²C interface, and three USARTs. The modular design of the peripheral set allows the same peripherals to be found in different ST microcontroller families including 32-bit families. This makes any transition to a different family very easy, and simplified even more by the use of a common set of development tools.

2.1 STM8L Ultralow power 8-bit family benefits

High density STM8L162xx devices are part of the STM8L Ultralow power family providing the following benefits:

- Integrated system
 - 64 Kbytes of high-density embedded Flash program memory
 - 2 Kbytes of data EEPROM
 - 4 Kbytes of RAM
 - Internal high-speed and low-power low speed RC.
 - Embedded reset
- Ultralow power consumption
 - 1 μ A in Active-halt mode
 - Clock gated system and optimized power management
 - Capability to execute from RAM for Low power wait mode and Low power run mode
- Advanced features
 - Up to 16 MIPS at 16 MHz CPU clock frequency
 - Direct memory access (DMA) for memory-to-memory or peripheral-to-memory access.
- Short development cycles
 - Application scalability across a common family product architecture with compatible pinout, memory map and modular peripherals.
 - Wide choice of development tools

STM8L Ultralow power microcontrollers can operate either from 1.8 to 3.6 V (down to 1.65 V at power-down) or from 1.65 to 3.6 V. They are available in the -40 to $+85$ °C and -40 to $+125$ °C temperature ranges.

These features make the STM8L Ultralow power microcontroller families suitable for a wide range of applications:

- Medical and handheld equipment
- Application control and user interface
- PC peripherals, gaming, GPS and sport equipment
- Alarm systems, wired and wireless sensors
- Metering

The devices are offered in four different packages from 48 to 80 pins. Different sets of peripherals are included depending on the device. Refer to [Section 3](#) for an overview of the complete range of peripherals proposed in this family.

All STM8L Ultralow power products are based on the same architecture with the same memory mapping and a coherent pinout.

[Figure 1](#) shows the block diagram of the High density STM8L162xx families.

2.2 Device overview

Table 1. High density STM8L162x low power device features and peripheral counts

Features		STM8L162R8	STM8L162M8
Flash (Kbytes)		64	64
Data EEPROM (Kbytes)		2	2
RAM (Kbytes)		4	4
AES		1	1
LCD		8x36 or 4x40	8x40 or 4x44
Timers	Basic	1 (8-bit)	1 (8-bit)
	General purpose	3 (16-bit)	3 (16-bit)
	Advanced control	1 (16-bit)	1 (16-bit)
Communication interfaces	SPI	2	2
	I2C	1	1
	USART	3	3
GPIOs		54 ⁽¹⁾	68 ⁽¹⁾
12-bit synchronized ADC (number of channels)		1 (28)	1 (28)
12-Bit DAC Number of channels		2 2	2 2
Comparators (COMP1/COMP2)		2	2
Others		RTC, window watchdog, independent watchdog, 16-MHz and 38-kHz internal RC, 1- to 16-MHz and 32-kHz external oscillator	
CPU frequency		16 MHz	
Operating voltage		1.8 to 3.6 V (down to 1.65 V at power-down) with BOR 1.65 to 3.6 V without BOR	
Operating temperature		– 40 to +85 °C / – 40 to +125 °C	
Packages		LQFP64	LQFP80

1. The number of GPIOs given in this table includes the NRST/PA1 pin but the application can use the NRST/PA1 pin as general purpose output only (PA1).

2.3 Ultralow power continuum

The Ultralow power STM8L151xx, STM8L152xx and STM8L162xx are fully pin-to-pin, software and feature compatible. Besides the full compatibility within the family, the devices are part of STMicroelectronics microcontrollers UltraLow power strategy which also includes STM8L101xx and STM32L15xxx. The STM8L and STM32L families allow a continuum of performance, peripherals, system architecture, and features.

They are all based on STMicroelectronics 0.13 μm Ultralow leakage process.

- Note:*
- 1 The STM8L151xx and STM8L152xx are pin-to-pin compatible with STM8L101xx devices.
 - 2 The STM32L family is pin-to-pin compatible with the general purpose STM32F family. Please refer to STM32L15xx documentation for more information on these devices.

Performance

All families incorporate highly energy-efficient cores with both Harvard architecture and pipelined execution: advanced STM8 core for STM8L families and ARM Cortex™-M3 core for STM32L family. In addition specific care for the design architecture has been taken to optimize the mA/DMIPS and mA/MHz ratios.

This allows the Ultralow power performance to range from 5 up to 33.3 DMIPs.

Shared peripherals

STM8L151xx/152xx/162xx and STM32L15xx share identical peripherals which ensure a very easy migration from one family to another:

- Analog peripherals: ADC1, DAC1/DAC2, and comparators COMP1/COMP2
- Digital peripherals: RTC and some communication interfaces

Common system strategy

To offer flexibility and optimize performance, the STM8L15xx/162xx and STM32L15xx devices use a common architecture:

- Same power supply range from 1.65 to 3.6 V. For STM8L101xx and medium density STM8L15xx, the power supply must be above 1.8 V at power-on, and go below 1.65 V at power-down.
- Architecture optimized to reach ultralow consumption both in low power modes and Run mode
- Fast startup strategy from low power modes
- Flexible system clock
- Ultrasafe reset: same reset strategy for both STM8L15xx/162xx and STM32L15xx including power-on reset, power-down reset, brownout reset and programmable voltage detector.

Features

ST UltraLow power continuum also lies in feature compatibility:

- More than 10 packages with pin count from 20 to 100 pins and size down to 3 x 3 mm
- Memory density ranging from 4 to 128 Kbytes

3 Functional overview

Figure 1. High density STM8L162xx device block diagram

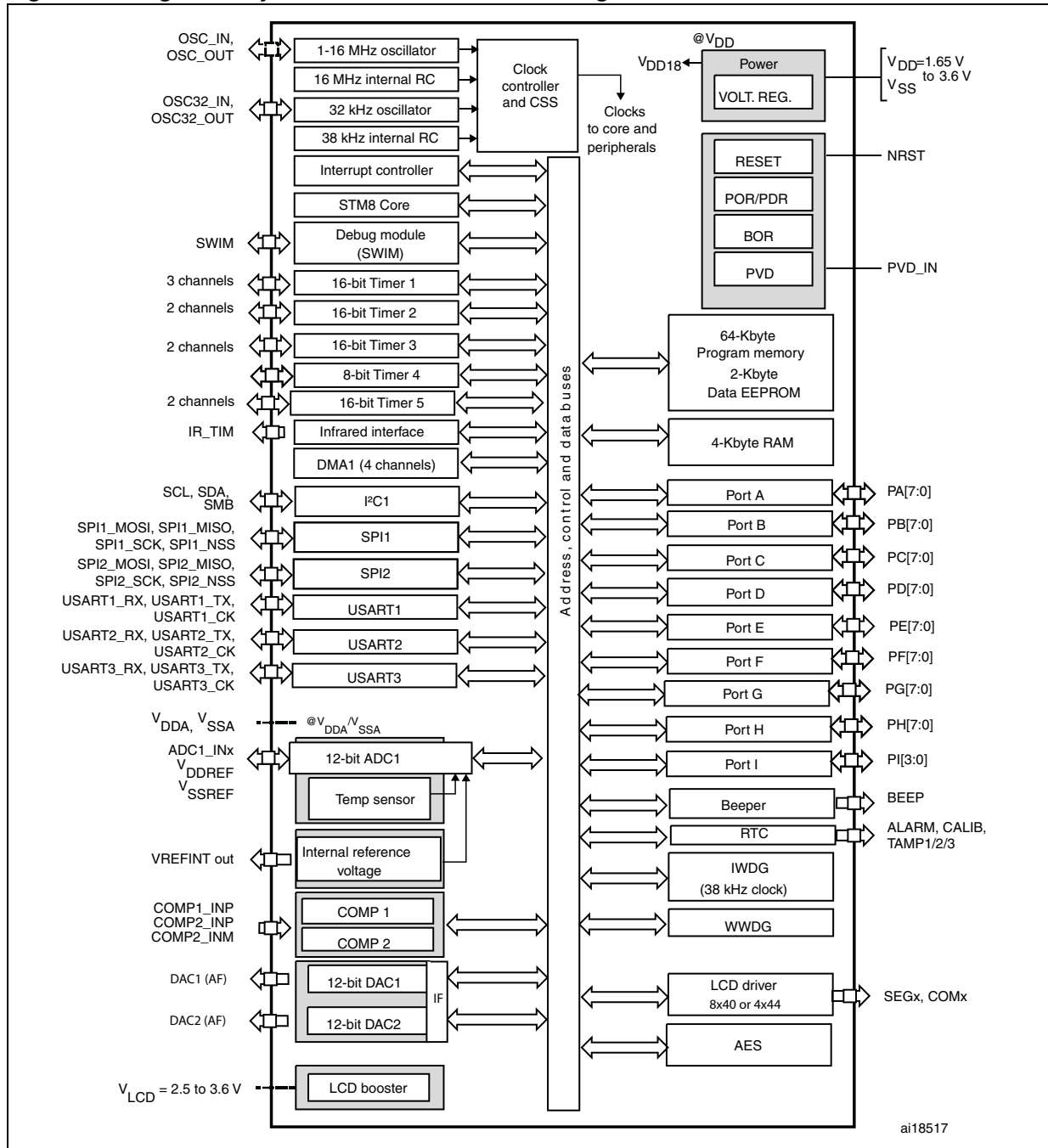

- Legend:**
 - AF: alternate function
 - ADC: Analog-to-digital converter
 - AES: Advanced encryption standard hardware accelerator
 - BOR: Brownout reset
 - DMA: Direct memory access
 - DAC: Digital-to-analog converter
 - I²C: Inter-integrated circuit multimaster interface

IWDG: Independent watchdog
LCD: Liquid crystal display
POR/PDR: Power on reset / power-down reset
RTC: Real-time clock
SPI: Serial peripheral interface
SWIM: Single wire interface module
USART: Universal synchronous asynchronous receiver transmitter
WWDG: Window watchdog

3.1 Low power modes

The high density STM8L162xx devices support five low power modes to achieve the best compromise between low power consumption, short startup time and available wakeup sources:

- **Wait mode:** CPU clock is stopped, but selected peripherals keep running. An internal or external interrupt or a Reset can be used to exit the microcontroller from Wait mode (WFE or WFI mode).
- **Low power run mode:** The CPU and the selected peripherals are running. Execution is done from RAM with a low speed oscillator (LSI or LSE). Flash memory and data EEPROM are stopped and the voltage regulator is configured in Ultralow power mode. The microcontroller enters Low power run mode by software and can exit from this mode by software or by a reset.
All interrupts must be masked. They cannot be used to exit the microcontroller from this mode.
- **Low power wait mode:** This mode is entered when executing a Wait for event in Low power run mode. It is similar to Low power run mode except that the CPU clock is stopped. The wakeup from this mode is triggered by a Reset or by an internal or external event (peripheral event generated by the timers, serial interfaces, DMA controller (DMA1), comparators and I/O ports). When the wakeup is triggered by an event, the system goes back to Low power run mode.
All interrupts must be masked. They cannot be used to exit the microcontroller from this mode.
- **Active-halt mode:** CPU and peripheral clocks are stopped, except RTC. The wakeup can be triggered by RTC interrupts, external interrupts or reset.
- **Halt mode:** CPU and peripheral clocks are stopped, the device remains powered on. The RAM content is preserved. The wakeup is triggered by an external interrupt or reset. A few peripherals have also a wakeup from Halt capability. Switching off the internal reference voltage reduces power consumption. Through software configuration it is also possible to wake up the device without waiting for the internal reference voltage wakeup time to have a fast wakeup time of 5 μ s.

3.2 Central processing unit STM8

3.2.1 Advanced STM8 Core

The 8-bit STM8 core is designed for code efficiency and performance with an Harvard architecture and a 3-stage pipeline.

It contains 6 internal registers which are directly addressable in each execution context, 20 addressing modes including indexed indirect and relative addressing, and 80 instructions.

Architecture and registers

- Harvard architecture
- 3-stage pipeline
- 32-bit wide program memory bus - single cycle fetching most instructions
- X and Y 16-bit index registers - enabling indexed addressing modes with or without offset and read-modify-write type data manipulations
- 8-bit accumulator
- 24-bit program counter - 16 Mbyte linear memory space
- 16-bit stack pointer - access to a 64 Kbyte level stack
- 8-bit condition code register - 7 condition flags for the result of the last instruction

Addressing

- 20 addressing modes
- Indexed indirect addressing mode for lookup tables located anywhere in the address space
- Stack pointer relative addressing mode for local variables and parameter passing

Instruction set

- 80 instructions with 2-byte average instruction size
- Standard data movement and logic/arithmetic functions
- 8-bit by 8-bit multiplication
- 16-bit by 8-bit and 16-bit by 16-bit division
- Bit manipulation
- Data transfer between stack and accumulator (push/pop) with direct stack access
- Data transfer using the X and Y registers or direct memory-to-memory transfers

3.2.2 Interrupt controller

The high density STM8L162xx devices feature a nested vectored interrupt controller:

- Nested interrupts with 3 software priority levels
- 32 interrupt vectors with hardware priority
- Up to 40 external interrupt sources on 11 vectors
- Trap and reset interrupts

3.3 Reset and supply management

3.3.1 Power supply scheme

The device requires a 1.65 V to 3.6 V operating supply voltage (V_{DD}). The external power supply pins must be connected as follows:

- V_{SS1} , V_{DD1} , V_{SS2} , V_{DD2} , V_{SS3} , V_{DD3} , V_{SS4} , V_{DD4} = 1.65 to 3.6 V: external power supply for I/Os and for the internal regulator. Provided externally through V_{DD} pins, the corresponding ground pin is V_{SS} . $V_{SS1}/V_{SS2}/V_{SS3}/V_{SS4}$ and $V_{DD1}/V_{DD2}/V_{DD3}/V_{DD4}$ must not be left unconnected.
- V_{SSA} , V_{DDA} = 1.65 to 3.6 V: external power supplies for analog peripherals (minimum voltage to be applied to V_{DDA} is 1.8 V when the ADC1 is used). V_{DDA} and V_{SSA} must be connected to V_{DD} and V_{SS} , respectively.
- V_{REF+} , V_{REF-} (for ADC1): external reference voltage for ADC1. Must be provided externally through V_{REF+} and V_{REF-} pin.
- V_{REF+} (for DAC1/2): external voltage reference for DAC1 and DAC2 must be provided externally through V_{REF+} .

3.3.2 Power supply supervisor

The device has an integrated ZEROPOWER power-on reset (POR)/power-down reset (PDR). For the device sales types without the “D” option (see [Section 11: Ordering information scheme](#)), it is coupled with a brownout reset (BOR) circuitry. In that case the device operates between 1.8 and 3.6 V, BOR is always active and ensures proper operation starting from 1.8 V. After the 1.8 V BOR threshold is reached, the option byte loading process starts, either to confirm or modify default thresholds, or to disable BOR permanently (in which case, the V_{DD} min. value at power-down is 1.65 V).

Five BOR thresholds are available through option bytes, starting from 1.8 V to 3 V. To reduce the power consumption in Halt mode, it is possible to automatically switch off the internal reference voltage (and consequently the BOR) in Halt mode. The device remains in reset state when V_{DD} is below a specified threshold, $V_{POR/PDR}$ or V_{BOR} , without the need for any external reset circuit.

Note: For device sales types with the “D” option (see [Section 11: Ordering information scheme](#)) BOR is permanently disabled and the device operates between 1.65 and 3.6 V. In this case it is not possible to enable BOR through the option bytes.

The device features an embedded programmable voltage detector (PVD) that monitors the V_{DD}/V_{DDA} power supply and compares it to the V_{PVD} threshold. This PVD offers 7 different levels between 1.85 V and 3.05 V, chosen by software, with a step around 200 mV. An interrupt can be generated when V_{DD}/V_{DDA} drops below the V_{PVD} threshold and/or when V_{DD}/V_{DDA} is higher than the V_{PVD} threshold. The interrupt service routine can then generate a warning message and/or put the MCU into a safe state. The PVD is enabled by software.

3.3.3 Voltage regulator

The high density STM8L162xx devices embed an internal voltage regulator for generating the 1.8 V power supply for the core and peripherals.

This regulator has two different modes:

- Main voltage regulator mode (MVR) for Run, Wait for interrupt (WFI) and Wait for event (WFE) modes.
- Low power voltage regulator mode (LPVR) for Halt, Active-halt, Low power run and Low power wait modes.

When entering Halt or Active-halt modes, the system automatically switches from the MVR to the LPVR in order to reduce current consumption.

3.4 Clock management

The clock controller distributes the system clock (SYSCLK) coming from different oscillators to the core and the peripherals. It also manages clock gating for low power modes and ensures clock robustness.

Features

- **Clock prescaler:** to get the best compromise between speed and current consumption the clock frequency to the CPU and peripherals can be adjusted by a programmable prescaler
- **Safe clock switching:** Clock sources can be changed safely on the fly in run mode through a configuration register.
- **Clock management:** To reduce power consumption, the clock controller can stop the clock to the core, individual peripherals or memory.
- **System clock sources:** 4 different clock sources can be used to drive the system clock:
 - 1-16 MHz High speed external crystal (HSE)
 - 16 MHz High speed internal RC oscillator (HSI)
 - 32.768 Low speed external crystal (LSE)
 - 38 kHz Low speed internal RC (LSI)
- **RTC and LCD clock sources:** the above four sources can be chosen to clock the RTC and the LCD, whatever the system clock.
- **Startup clock:** After reset, the microcontroller restarts by default with an internal 2 MHz clock (HSI/8). The prescaler ratio and clock source can be changed by the application program as soon as the code execution starts.
- **Clock security system (CSS):** This feature can be enabled by software. If a HSE clock failure occurs, the system clock is automatically switched to HSI.
- **Configurable main clock output (CCO):** This outputs an external clock for use by the application.

Figure 2. Clock tree diagram

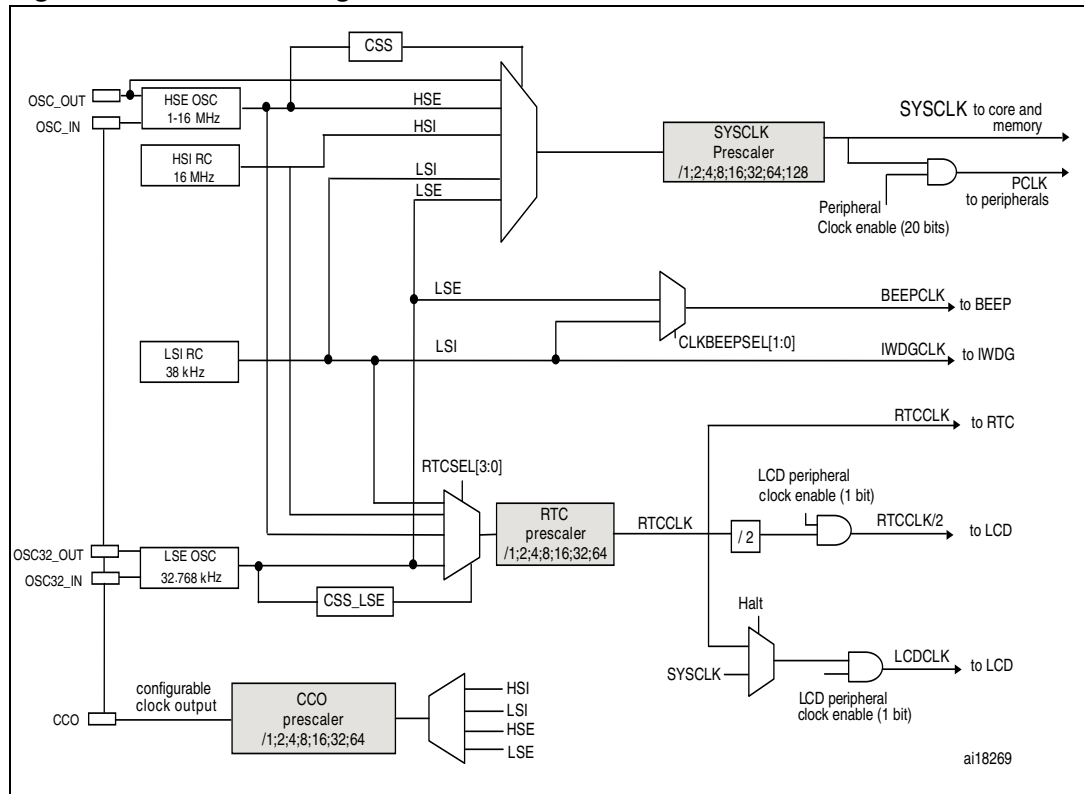

3.5 Low power real-time clock

The real-time clock (RTC) is an independent binary coded decimal (BCD) timer/counter.

Six byte locations contain the second, minute, hour (12/24 hour), week day, date, month, year, in BCD (binary coded decimal) format. Correction for 28, 29 (leap year), 30, and 31 day months are made automatically. The subsecond field can also be read in binary format.

The calendar can be corrected from 1 to 32767 RTC clock pulses. This allows to make a synchronization to a master clock.

The RTC offers a digital calibration which allows an accuracy of +/-0.5ppm.

It provides a programmable alarm and programmable periodic interrupts with wakeup from Halt capability.

- Periodic wakeup time using the 32.768 kHz LSE with the lowest resolution (of 61 μs) is from min. 122 μs to max. 3.9 s. With a different resolution, the wakeup time can reach 36 hours
- Periodic alarms based on the calendar can also be generated from LSE period to every year

A clock security system detects a failure on LSE, and can provide an interrupt with wakeup capability. The RTC clock can automatically switch to LSI in case of LSE failure.

The RTC also provides 3 anti-tamper detection pins. This detection embeds a programmable filter and can wakeup the MCU.

3.6 LCD (Liquid crystal display)

The liquid crystal display drives up to 8 common terminals and up to 40 segment terminals to drive up to 320 pixels. It can also be configured to drive up to 4 common and 44 segments (up to 176 pixels).

- Internal step-up converter to guarantee contrast control whatever V_{DD} .
- Static 1/2, 1/3, 1/4, 1/8 duty supported.
- Static 1/2, 1/3, 1/4 bias supported.
- Phase inversion to reduce power consumption and EMI.
- Up to 8 pixels which can be programmed to blink.
- The LCD controller can operate in Halt mode.

Note: Unnecessary segments and common pins can be used as general I/O pins.

3.7 Memories

The high density STM8L162xx devices have the following main features:

- 4 Kbytes of RAM
- The non-volatile memory is divided into three arrays:
 - 64 Kbytes of medium-density embedded Flash program memory
 - 2 Kbytes of Data EEPROM
 - Option bytes.

The EEPROM embeds the error correction code (ECC) feature. It supports the read-while-write (RWW): it is possible to execute the code from the program matrix while programming/erasing the data matrix.

The option byte protects part of the Flash program memory from write and readout piracy.

3.8 DMA

A 4-channel direct memory access controller (DMA1) offers a memory-to-memory and peripherals-from/to-memory transfer capability. The 4 channels are shared between the following IPs with DMA capability: ADC1, DAC1, DAC2, AES, I2C1, SPI1, SPI2, USART1, USART2, USART3, and the 5 Timers.

3.9 Analog-to-digital converter

- 12-bit analog-to-digital converter (ADC1) with 28 channels (including 4 fast channel), temperature sensor and internal reference voltage
- Conversion time down to 1 μ s with $f_{\text{SYSCLK}} = 16$ MHz
- Programmable resolution
- Programmable sampling time
- Single and continuous mode of conversion
- Scan capability: automatic conversion performed on a selected group of analog inputs
- Analog watchdog: interrupt generation when the converted voltage is outside the programmed threshold
- Triggered by timer

Note: ADC1 can be served by DMA1.

3.10 Digital-to-analog converter

- 12-bit DAC with 2 buffered outputs (two digital signals can be converted into two analog voltage signal outputs)
- Synchronized update capability using timers
- DMA capability for each channel
- External triggers for conversion
- Noise-wave generation
- Triangular-wave generation
- Dual DAC channels with independent or simultaneous conversions
- Input reference voltage $V_{\text{REF+}}$ for better resolution

Note: DAC can be served by DMA1.

3.11 Ultralow power comparators

The high density STM8L162xx devices embed two comparators (COMP1 and COMP2) sharing the same current bias and voltage reference. The voltage reference can be internal or external (coming from an I/O).

- One comparator with fixed threshold (COMP1).
- One comparator rail to rail with fast or slow mode (COMP2). The threshold can be one of the following:
 - DAC output
 - External I/O
 - Internal reference voltage or internal reference voltage submultiple (1/4, 1/2, 3/4)

The two comparators can be used together to offer a window function. They can wake up from Halt mode.

3.12 System configuration controller and routing interface

The system configuration controller provides the capability to remap some alternate functions on different I/O ports. TIM4 and ADC1 DMA channels can also be remapped.

The highly flexible routing interface allows application software to control the routing of different I/Os to the TIM1 timer input captures. It also controls the routing of internal analog signals to ADC1, COMP1, COMP2, DAC1 and the internal reference voltage V_{REFINT} . It also provides a set of registers for efficiently managing the charge transfer acquisition sequence (see [Section 3.13: Touch sensing](#)).

3.13 Touch sensing

The high density STM8L162xx devices provide a simple solution for adding capacitive sensing functionality to any application. Capacitive sensing technology is able to detect finger presence near an electrode which is protected from direct touch by a dielectric (glass, plastic, ...). The capacitive variation introduced by the finger (or any conductive object) is measured using a proven implementation based on a surface charge transfer acquisition principle. It consists of charging the electrode capacitance and then transferring a part of the accumulated charges into a sampling capacitor until the voltage across this capacitor has reached a specific threshold. In the high density STM8L162xx devices, the acquisition sequence is managed by software and it involves analog I/O groups and the routing interface.

Reliable touch sensing solution can be quickly and easily implemented using the free STM8 touch sensing firmware library.

3.14 AES

The AES Hardware Accelerator can be used to encipher and decipher data using the AES algorithm (compatible with FIPS PUB 197, 2001 Nov 26).

- Key scheduler
- Key derivation for decryption
- 128-bit data block processed
- 128-bit key length
- 892 clock cycles to encrypt/decrypt one 128-bit block

AES data flow can be served by the DMA1 controller.

3.15 Timers

The high density STM8L162xx devices contain one advanced control timer (TIM1), three 16-bit general purpose timers (TIM2, TIM3 and TIM5) and one 8-bit basic timer (TIM4).

All the timers can be served by DMA1.

[Table 2](#) compares the features of the advanced control, general-purpose and basic timers.

Table 2. Timer feature comparison

Timer	Counter resolution	Counter type	Prescaler factor	DMA1 request generation	Capture/compare channels	Complementary outputs
TIM1	16-bit	up/down	Any integer from 1 to 65536	Yes	3 + 1	3
TIM2			Any power of 2 from 1 to 128		2	None
TIM3						
TIM5						
TIM4	8-bit	up	Any power of 2 from 1 to 32768		0	

3.15.1 16-bit advanced control timer (TIM1)

This is a high-end timer designed for a wide range of control applications. With its complementary outputs, dead-time control and center-aligned PWM capability, the field of applications is extended to motor control, lighting and half-bridge driver.

- 16-bit up, down and up/down autoreload counter with 16-bit prescaler
- 3 independent capture/compare channels (CAPCOM) configurable as input capture, output compare, PWM generation (edge and center aligned mode) and single pulse mode output
- 1 additional capture/compare channel which is not connected to an external I/O
- Synchronization module to control the timer with external signals
- Break input to force timer outputs into a defined state
- 3 complementary outputs with adjustable dead time
- Encoder mode
- Interrupt capability on various events (capture, compare, overflow, break, trigger)

3.15.2 16-bit general purpose timers (TIM2, TIM3, TIM5)

- 16-bit autoreload (AR) up/down-counter
- 7-bit prescaler adjustable to fixed power of 2 ratios (1...128)
- 2 individually configurable capture/compare channels
- PWM mode
- Interrupt capability on various events (capture, compare, overflow, break, trigger)
- Synchronization with other timers or external signals (external clock, reset, trigger and enable)

3.15.3 8-bit basic timer (TIM4)

The 8-bit timer consists of an 8-bit up auto-reload counter driven by a programmable prescaler. It can be used for timebase generation with interrupt generation on timer overflow or for DAC trigger generation.

3.16 Watchdog timers

The watchdog system is based on two independent timers providing maximum security to the applications.

3.16.1 Window watchdog timer

The window watchdog (WWDG) is used to detect the occurrence of a software fault, usually generated by external interferences or by unexpected logical conditions, which cause the application program to abandon its normal sequence.

3.16.2 Independent watchdog timer

The independent watchdog peripheral (IWDG) can be used to resolve processor malfunctions due to hardware or software failures.

It is clocked by the internal LSI RC clock source, and thus stays active even in case of a CPU clock failure.

3.17 Beeper

The beeper function outputs a signal on the BEEP pin for sound generation. The signal is in the range of 1, 2 or 4 kHz.

3.18 Communication interfaces

3.18.1 SPI

The serial peripheral interfaces (SPI1 and SPI2) provide half/ full duplex synchronous serial communication with external devices.

- Maximum speed: 8 Mbit/s ($f_{\text{SYSCLK}}/2$) both for master and slave
- Full duplex synchronous transfers
- Simplex synchronous transfers on 2 lines with a possible bidirectional data line
- Master or slave operation - selectable by hardware or software
- Hardware CRC calculation
- Slave/master selection input pin

Note: SPI1 and SPI2 can be served by the DMA1 Controller.

3.18.2 I²C

The I²C bus interface (I2C1) provides multi-master capability, and controls all I²C bus-specific sequencing, protocol, arbitration and timing.

- Master, slave and multi-master capability
- Standard mode up to 100 kHz and fast speed modes up to 400 kHz.
- 7-bit and 10-bit addressing modes.
- SMBus 2.0 and PMBus support
- Hardware CRC calculation

Note: $\dot{P}C1$ can be served by the DMA1 Controller.

3.18.3 USART

The USART interfaces (USART1, USART2 and USART3) allow full duplex, asynchronous communications with external devices requiring an industry standard NRZ asynchronous serial data format. It offers a very wide range of baud rates.

- 1 Mbit/s full duplex SCI
- SPI1 emulation
- High precision baud rate generator
- Smartcard emulation
- IrDA SIR encoder decoder
- Single wire half duplex mode

Note: USART1, USART2 and USART3 can be served by the DMA1 Controller.

3.19 Infrared (IR) interface

The high density STM8L162xx devices contain an infrared interface which can be used with an IR LED for remote control functions. Two timer output compare channels are used to generate the infrared remote control signals.

3.20 Development support

Development tools

Development tools for the STM8 microcontrollers include:

- The STice emulation system offering tracing and code profiling
- The STVD high-level language debugger including C compiler, assembler and integrated development environment
- The STVP Flash programming software

The STM8 also comes with starter kits, evaluation boards and low-cost in-circuit debugging/programming tools.

Single wire data interface (SWIM) and debug module

The debug module with its single wire data interface (SWIM) permits non-intrusive real-time in-circuit debugging and fast memory programming.

The Single wire interface is used for direct access to the debugging module and memory programming. The interface can be activated in all device operation modes.

The non-intrusive debugging module features a performance close to a full-featured emulator. Beside memory and peripherals, CPU operation can also be monitored in real-time by means of shadow registers.

Bootloader

A bootloader is available to reprogram the Flash memory using the USART1, USART2, USART3 (USARTs in asynchronous mode), SPI1 or SPI2 interfaces.

4 Pin description

Figure 3. STM8L162M8 80-pin package pinout

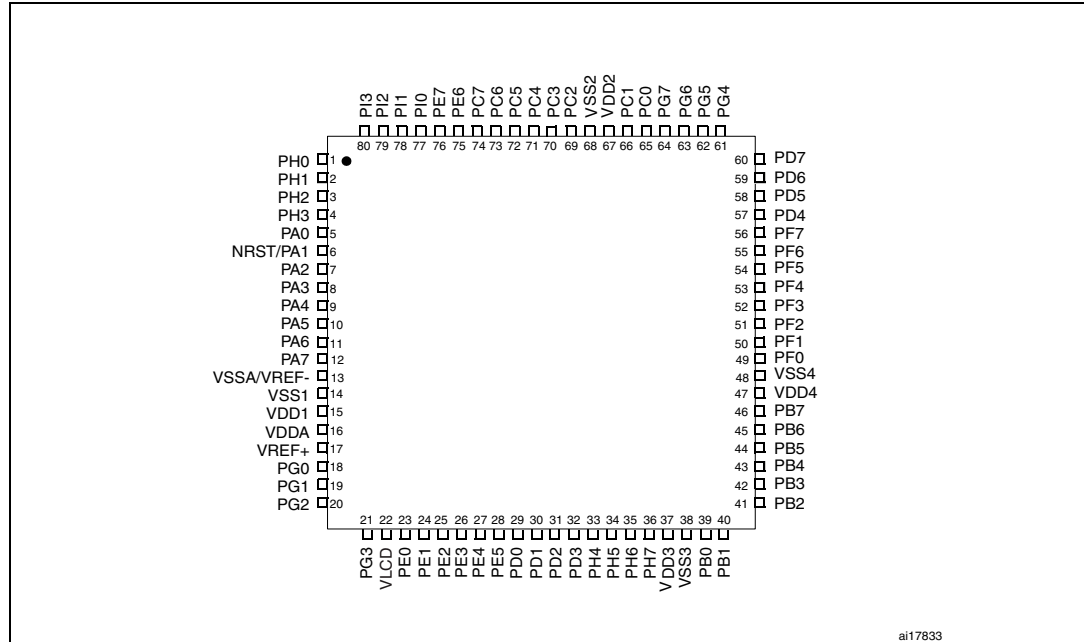

ai17833

Figure 4. STM8L162R8 64-pin pinout

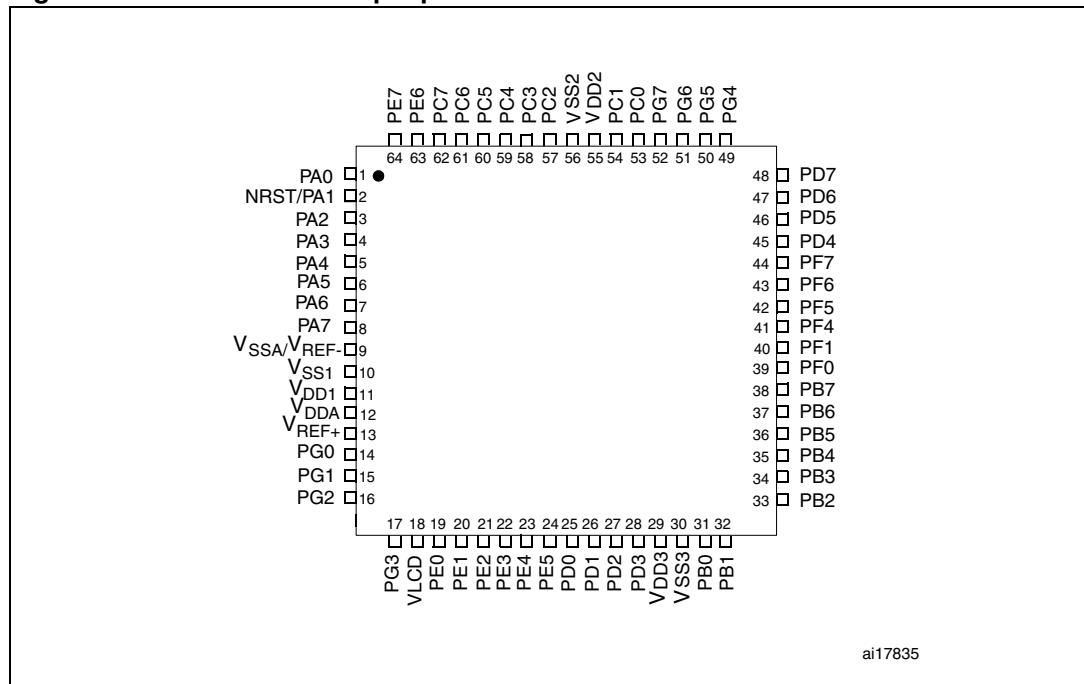

ai17835

Table 3. Legend/abbreviation

Type	I= input, O = output, S = power supply	
Level	FT: Five-volt tolerant	
	Output	HS = high sink/source (20 mA)
Port and control configuration	Input	float = floating, wpu = weak pull-up
	Output	T = true open drain, OD = open drain, PP = push pull
Reset state	Bold X (pin state after reset release). Unless otherwise specified, the pin state is the same during the reset phase (i.e. “under reset”) and after internal reset release (i.e. at reset state).	

Table 4. STM8L162x pin description

Pin number		Pin name	Type	I/O level	Input			Output			Main function (after reset)	Default alternate function
LQFP80	LQFP64				floating	wpu	Ext. interrupt	High sink/source	OD	PP		
1	-	PH0/LCD SEG 36	I/O		X	X	X	HS	X	X	Port H0	LCD segment 36
2	-	PH1/LCD SEG 37	I/O		X	X	X	HS	X	X	Port H1	LCD segment 37
3	-	PH2/LCD SEG 38	I/O		X	X	X	HS	X	X	Port H2	LCD segment 38
4	-	PH3/LCD SEG 39	I/O		X	X	X	HS	X	X	Port H3	LCD segment 39
6	2	NRST/PA1 ⁽¹⁾	I/O			X		HS	X	X	Reset	PA1
7	3	PA2/OSC_IN/ [USART1_TX] ⁽²⁾ / [SPI1_MISO] ⁽²⁾	I/O		X	X	X	HS	X	X	Port A2	HSE oscillator input / [USART1 transmit] / [SPI1 master in- slave out] /
8	4	PA3/OSC_OUT/[USART1_RX] ⁽²⁾ / [SPI1_MOSI] ⁽²⁾	I/O		X	X	X	HS	X	X	Port A3	HSE oscillator output / [USART1 receive] / [SPI1 master out/slave in]
9	5	PA4/TIM2_BKIN/ [TIM2_ETR] ⁽²⁾ LCD_COM0/ADC1_IN2/ COMP1_INP	I/O	FT (3)	X	X	X	HS	X	X	Port A4	Timer 2 - break input / [Timer 2 - trigger] / LCD COM 0 / ADC1 input 2/Comparator 1 positive input
10	6	PA5/TIM3_BKIN/ [TIM3_ETR] ⁽²⁾ /LCD_COM1 /ADC1_IN1/COMP1_INP	I/O	FT (3)	X	X	X	HS	X	X	Port A5	Timer 3 - break input / [Timer 3 - trigger] / LCD_COM 1 / ADC1 input 1/Comparator 1 positive input
11	7	PA6/ADC1_TRIG/ LCD_COM2/ADC1_IN0/ COMP1_INP	I/O	FT (3)	X	X	X	HS	X	X	Port A6	ADC1 - trigger / LCD_COM2 / ADC1 input 0/Comparator 1 positive input
12	8	PA7/LCD_SEG0/ TIM5_CH1	I/O	FT (3)	X	X	X	HS	X	X	Port A7	LCD segment 0 / TIM5 channel 1

Table 4. STM8L162x pin description (continued)

Pin number		Pin name	Type	I/O level	Input			Output			Main function (after reset)	Default alternate function
LQFP80	LQFP64				floating	wpu	Ext. interrupt	High sink/source	OD	PP		
39	31	PB0 ⁽⁴⁾ /TIM2_CH1/ LCD_SEG10/ADC1_IN18/ COMP1_INP	I/O	FT (3)	X	X	X	HS	X	X	Port B0	Timer 2 - channel 1 / LCD segment 10 / ADC1_IN18/Comparator 1 positive input
40	32	PB1/TIM3_CH1/ LCD_SEG11/ADC1_IN17/ COMP1_INP	I/O	FT (3)	X	X	X	HS	X	X	Port B1	Timer 3 - channel 1 / LCD segment 11 / ADC1_IN17/Comparator 1 positive input
41	33	PB2/TIM2_CH2/ LCD_SEG12/ADC1_IN16/ COMP1_INP	I/O	FT (3)	X	X	X	HS	X	X	Port B2	Timer 2 - channel 2 / LCD segment 12 / ADC1_IN16/Comparator 1 positive input
42	34	PB3/TIM2_ETR/ LCD_SEG13/ ADC1_IN15/COMP1_INP	I/O	FT (3)	X	X	X	HS	X	X	Port B3	Timer 2 - trigger / LCD segment 13 / ADC1_IN15/Comparator 1 positive input
43	35	PB4 ⁽⁴⁾ /SPI1_NSS/ LCD_SEG14/ADC1_IN14/ COMP1_INP	I/O	FT (3)	X	X	X	HS	X	X	Port B4	SPI1 master/slave select / LCD segment 14 / ADC1_IN14/Comparator 1 positive input
44	36	PB5/SPI1_SCK/ LCD_SEG15/ADC1_IN13/ COMP1_INP	I/O	FT (3)	X	X	X	HS	X	X	Port B5	SPI1 clock / LCD segment 15 / ADC1_IN13/Comparator 1 positive input
45	37	PB6/SPI1_MOSI/ LCD_SEG16/ ADC1_IN12/COMP1_INP	I/O	FT (3)	X	X	X	HS	X	X	Port B6	SPI1 master out/slave in/ LCD segment 16 / ADC1_IN12/Comparator 1 positive input
46	38	PB7/SPI1_MISO/ LCD_SEG17/ADC1_IN11/ COMP1_INP	I/O	FT (3)	X	X	X	HS	X	X	Port B7	SPI1 master in- slave out/ LCD segment 17 / ADC1_IN11/Comparator 1 positive input
65	53	PC0/I2C1_SDA	I/O	FT (3)	X		X			T ⁽⁵⁾	Port C0	I2C1 data
66	54	PC1/I2C1_SCL	I/O	FT (3)	X		X			T ⁽⁵⁾	Port C1	I2C1 clock
69	57	PC2/USART1_RX/ LCD_SEG22/ADC1_IN6/ COMP1_INP/VREFINT	I/O	FT (3)	X	X	X	HS	X	X	Port C2	USART1 receive / LCD segment 22 / ADC1_IN6/Comparator 1 positive input/Internal reference voltage output

Table 4. STM8L162x pin description (continued)

Pin number		Pin name	Type	I/O level	Input			Output			Main function (after reset)	Default alternate function
LQFP80	LQFP64				floating	wpu	Ext. interrupt	High sink/source	OD	PP		
70	58	PC3/USART1_TX/ LCD_SEG23/ADC1_IN5/ COMP_IN3M/ COMP2_INM/COMP1_INP	I/O	FT (3)	X	X	X	HS	X	X	Port C3	USART1 transmit / LCD segment 23 / ADC1_IN5 / Comparator 2 negative input /Comparator 1 input positive
71	59	PC4/USART1_CK/ I2C1_SMB/CCO/ LCD_SEG24/ADC1_IN4/ COMP2_INM/COMP1_INP	I/O	FT (3)	X	X	X	HS	X	X	Port C4	USART1 synchronous clock / I2C1_SMB / Configurable clock output / LCD segment 24 / ADC1_IN4 / Comparator 2 negative input / Comparator 1 positive input
72	60	PC5/OSC32_IN /[SPI1_NSS] ⁽²⁾ / [USART1_TX] ⁽²⁾	I/O	FT (3)	X	X	X	HS	X	X	Port C5	LSE oscillator input / [SPI1 master/slave select] / [USART1 transmit]
73	61	PC6/OSC32_OUT/ [SPI1_SCK] ⁽²⁾ / [USART1_RX] ⁽²⁾	I/O	FT (3)	X	X	X	HS	X	X	Port C6	LSE oscillator output / [SPI1 clock] / [USART1 receive]
74	62	PC7/LCD_SEG25/ ADC1_IN3/COMP2_INM ⁽⁶⁾ / COMP1_INP	I/O	FT (3)	X	X	X	HS	X	X	Port C7	LCD segment 25 /ADC1_IN3/ Comparator negative input / Comparator 1 positive input
29	25	PD0/TIM3_CH2/ [ADC1_TRIG] ⁽²⁾ / LCD_SEG7/ADC1_IN22/ COMP2_INP	I/O	FT (3)	X	X	X	HS	X	X	Port D0	Timer 3 - channel 2 / [ADC1_Trigger] / LCD segment 7 / ADC1_IN22 / Comparator 2 positive input 2
30	26	PD1/TIM3_ETR/ LCD_COM3/ADC1_IN21/ COMP1_INP/COMP2_INP	I/O	FT (3)	X	X	X	HS	X	X	Port D1	Timer 3 - trigger / LCD_COM3 / ADC1_IN21 / comparator 1 positive input/ comparator 2 positive input
31	27	PD2/TIM1_CH1 /LCD_SEG8/ADC1_IN20/ COMP1_INP	I/O	FT (3)	X	X	X	HS	X	X	Port D2	Timer 1 - channel 1 / LCD segment 8 / ADC1_IN20/Comparator 1 positive input
32	28	PD3/ TIM1_ETR/ LCD_SEG9/ADC1_IN19/ COMP1_INP	I/O	FT (3)	X	X	X	HS	X	X	Port D3	Timer 1 - trigger / LCD segment 9 / ADC1_IN19/Comparator 1 positive input
57	45	PD4/TIM1_CH2/ LCD_SEG18/ADC1_IN10/ COMP1_INP	I/O	FT (3)	X	X	X	HS	X	X	Port D4	Timer 1 - channel 2 / LCD segment 18 / ADC1_IN10/Comparator 1 positive input

Table 4. STM8L162x pin description (continued)

Pin number		Pin name	Type	I/O level	Input			Output			Main function (after reset)	Default alternate function
LQFP80	LQFP64				floating	wpu	Ext. interrupt	High sink/source	OD	PP		
58	46	PD5/TIM1_CH3/ LCD_SEG19/ADC1_IN9/ COMP1_INP	I/O	FT (3)	X	X	X	HS	X	X	Port D5	Timer 1 - channel 3 / LCD segment 19 / ADC1_IN9/Comparator 1 positive input
59	47	PD6/TIM1_BKIN/ LCD_SEG20/ADC1_IN8/ RTC_CALIB/COMP1_INP/ VREFINT	I/O	FT (3)	X	X	X	HS	X	X	Port D6	Timer 1 - break input /LCD segment 20/ADC1_IN8 / RTC calibration/Comparator 1 positive input/Internal reference voltage output
60	48	PD7/TIM1_CH1N/ LCD_SEG21/ADC1_IN7/R TC_ALARM/COMP1_INP/ VREFINT	I/O	FT (3)	X	X	X	HS	X	X	Port D7	Timer 1 - inverted channel 1/ LCD segment 21/ADC1_IN7/ RTC alarm/Comparator 1 positive input/Internal reference voltage output
61	49	PG4/LCD_SEG32/ SPI2_NSS	I/O	FT (3)	X	X	X	HS	X	X	Port G4	LCD segment 32 / SPI2 master/slave select
62	50	PG5/LCD_SEG33/ SPI2_SCK	I/O	FT (3)	X	X	X	HS	X	X	Port G5	LCD segment 33 / SPI2 clock
63	51	PG6/LCD_SEG34/ SPI2_MOSI	I/O	FT (3)	X	X	X	HS	X	X	Port G6	LCD segment 34 / SPI2 master out- slave in
64	52	PG7/LCD_SEG35/ SPI2_MISO	I/O	FT (3)	X	X	X	HS	X	X	Port G7	LCD segment 35 / SPI2 master in- slave out
23	-	PE0/LCD_SEG1/ TIM5_CH2	I/O	FT (3)	X	X	X	HS	X	X	Port E0	LCD segment 1 /Timer 5 channel 2
-	19	PE0/LCD_SEG1/ TIM5_CH2/RTC_TAMP1	I/O	FT (3)	X	X	X	HS	X	X	Port E0	LCD segment 1 /Timer 5 channel 2 / RTC tamper 1
24	-	PE1/TIM1_CH2N/ LCD_SEG2	I/O	FT (3)	X	X	X	HS	X	X	Port E1	Timer 1 - inverted channel 2 / LCD segment 2
-	20	PE1/TIM1_CH2N/ LCD_SEG2/RTC_TAMP2	I/O	FT (3)	X	X	X	HS	X	X	Port E1	Timer 1 - inverted channel 2 / LCD segment 2 / RTC tamper 2
25	-	PE2/TIM1_CH3N/ LCD_SEG3	I/O	FT (3)	X	X	X	HS	X	X	Port E2	Timer 1 - inverted channel 3 / LCD segment 3
-	21	PE2/TIM1_CH3N/ LCD_SEG3/RTC_TAMP3	I/O	FT (3)	X	X	X	HS	X	X	Port E2	Timer 1 - inverted channel 3 / LCD segment 3 / RTC tamper 3
26	-	PE3/LCD_SEG4	I/O	FT (3)	X	X	X	HS	X	X	Port E3	LCD segment 4

Table 4. STM8L162x pin description (continued)

Pin number		Pin name	Type	I/O level	Input			Output			Main function (after reset)	Default alternate function
LQFP80	LQFP64				floating	wpu	Ext. interrupt	High sink/source	OD	PP		
-	22	PE3/LCD_SEG4/ USART2_RX	I/O	FT (3)	X	X	X	HS	X	X	Port E3	LCD segment 4/ USART2 receive
27	-	PE4/LCD_SEG5/ DAC_TRIG1	I/O	FT (3)	X	X	X	HS	X	X	Port E4	LCD segment 5/ DAC 1 trigger
-	23	PE4/LCD_SEG5/ DAC_TRIG2/USART2_TX	I/O	FT (3)	X	X	X	HS	X	X	Port E4	LCD segment 5/ DAC 2 trigger/ USART2 transmit
28	-	PE5/LCD_SEG6/ ADC1_IN23/COMP1_INP/ COMP2_INP	I/O	FT (3)	X	X	X	HS	X	X	Port E5	LCD segment 6 / ADC1_IN23/Comparator 1 positive input/Comparator 2 positive input
-	24	PE5/LCD_SEG6/ ADC1_IN23/COMP1_INP/ COMP2_INP/USART2_CK	I/O	FT (3)	X	X	X	HS	X	X	Port E5	LCD segment 6 / ADC1_IN23/ Comparator 1 positive input/ Comparator 2 positive input/USART2 synchronous clock
75	63	PE6/LCD_SEG26/ PVD_IN/TIM5_BKIN	I/O	FT (3)	X	X	X	HS	X	X	Port E6	LCD segment 26 /PVD_IN /TIM5 break input
76	64	PE7/LED_SEG27/ TIM5_ETR	I/O	FT (3)	X	X	X	HS	X	X	Port E7	LCD segment 27/ TIM5 trigger
77	-	PI0/RTC_TAMP1/ [SPI2_NSS]/[TIM3_CH3]	I/O	FT (3)	X	X	X	HS	X	X	Port I0	RTC tamper 1 output [SPI2 master/slave select] [TIM3 channel 3]
78	-	PI1/RTC_TAMP2/ [SPI2_SCK]	I/O	FT (3)	X	X	X	HS	X	X	Port I1	RTC tamper 2 output [SPI2 clock]
79	-	PI2/RTC_TAMP3/ [SPI2_MOSI]	I/O	FT (3)	X	X	X	HS	X	X	Port I2	RTC tamper 3 output [SPI2 master out- slave in]
80	-	PI3/TIM5_CH1/ [SPI2_MISO]/[TIM3_CH2]	I/O	FT (3)	X	X	X	HS	X	X	Port I3	TIM5 Channel 1 [SPI2 master in- slave out] [TIM3 channel 2]
-	39	PF0/ADC1_IN24/ DAC_OUT1 [USART3_TX]	I/O		X	X	X	HS	X	X	Port F0	ADC1_IN24 / DAC 1 output/ [USART3 transmit]
49	-	PF0/ADC1_IN24/ DAC_OUT1/[USART3_TX] [SPI1_MISO]	I/O		X	X	X	HS	X	X	Port F0	ADC1_IN24 / DAC 1 output/ [USART3 transmit] [SPI1 master in- slave out]

Table 4. STM8L162x pin description (continued)

Pin number		Pin name	Type	I/O level	Input			Output			Main function (after reset)	Default alternate function
LQFP80	LQFP64				floating	wpu	Ext. interrupt	High sink/source	OD	PP		
50	-	PF1/ADC1_IN25/ DAC_OUT2/ [USART3_RX]/ [SPI1_MOSI]	I/O		X	X	X	HS	X	X	Port F1	ADC1_IN25/ DAC channel 2 output/ [USART3 receive] [SPI1 master out- slave in]
-	40	PF1/ADC1_IN25/ DAC_OUT2/[USART3_RX]	I/O		X	X	X	HS	X	X	Port F1	ADC1_IN25/ DAC channel 2 output/ [USART3 receive]
51	-	PF2/ADC1_IN26/ [SPI2_SCK]/ [USART3_SCK]	I/O		X	X	X	HS	X	X	Port F2	ADC1_IN26 [SPI2 clock] [USART3 clock]
52	-	PF3/ADC1_IN27/ [SPI1_NSS]	I/O		X	X	X	HS	X	X	Port F3	ADC1_IN26 [SPI1 master/slave select]
53	41	PF4/LCD_SEG36/ /LCD_COM4 ⁽⁷⁾	I/O	FT (3)	X	X	X	HS	X	X	Port F4	LCD_SEG36/ LCD COM4 ⁽⁷⁾
54	42	PF5/LCD_SEG37/ LCD_COM5 ⁽⁷⁾	I/O	FT (3)	X	X	X	HS	X	X	Port F5	LCD_SEG37/ LCD COM5 ⁽⁷⁾
55	43	PF6/LCD_SEG38/ LCD_COM6 ⁽⁷⁾	I/O	FT (3)	X	X	X	HS	X	X	Port F6	LCD_SEG38/ LCD COM6 ⁽⁷⁾
56	44	PF7/LCD_SEG39/ LCD_COM7 ⁽⁷⁾	I/O	FT (3)	X	X	X	HS	X	X	Port F7	LCD_SEG39/ LCD COM7 ⁽⁷⁾
22	18	VLCD	S									LCD booster external capacitor
15	11	V _{DD1}	S									Digital power supply
14	10	V _{SS1}										I/O ground
16	12	V _{DDA}	S									Analog supply voltage
17	13	V _{REF+} /V _{REF+_DAC}	S									ADC1 and DAC1/2 positive voltage reference
18	14	PG0/LCD SEG28/ USART3_RX/[TIM2_BKIN]	I/O	FT (3)	X	X	X	HS	X	X	Port G0	LCD segment 28/ USART3 receive / [Timer 2 - break input]
19	15	PG1/LCD SEG29/ USART3_TX/[TIM3_BKIN]	I/O	FT (3)	X	X	X	HS	X	X	Port G1	LCD segment 29/ USART3 transmit / [Timer 3 -break input]
20	16	PG2/LCD_SEG 30/ USART3_CK	I/O	FT (3)	X	X	X	HS	X	X	Port G2	LCD segment 30/ USART 3 synchronous clock
21	17	PG3/LCD SEG 31/ [TIM3_ETR]	I/O	FT (3)	X	X	X	HS	X	X	Port G3	LCD segment 31/ [Timer 3 - trigger]

Table 4. STM8L162x pin description (continued)

Pin number		Pin name	Type	I/O level	Input			Output			Main function (after reset)	Default alternate function
LQFP80	LQFP64				floating	wpu	Ext. interrupt	High sink/source	OD	PP		
33		PH4/USART2_RX	I/O	FT ⁽³⁾	X	X	X	HS	X	X	Port H4	USART2 receive
34		PH5/USART2_TX	I/O	FT ⁽³⁾	X	X	X	HS	X	X	Port H5	USART2 transmit
35		PH6/USART2_CK/ TIM5_CH1	I/O	FT ⁽³⁾	X	X	X	HS	X	X	Port H6	USART2 synchronous clock/Timer 5 - channel 1
36		PH7/TIM5_CH2	I/O	FT ⁽³⁾	X	X	X	HS	X	X	Port H7	Timer 5 - channel 2
13	9	V _{SSA} /V _{REF-}	S									Analog ground voltage / ADC1 negative voltage reference
37	29	V _{DD3}	S									IOs supply voltage
38	30	V _{SS3}	S									IOs ground voltage
5	1	PA0 ⁽⁸⁾ /[USART1_CK] ⁽²⁾ / SWIM/BEEP/IR_TIM ⁽⁹⁾	I/O		X	X	X	HS ⁽⁹⁾	X	X	Port A0	[USART1 synchronous clock] ⁽²⁾ / SWIM input and output / Beep output / Infrared Timer output
68	56	V _{SS2}										IOs ground voltage
67	55	V _{DD2}										IOs supply voltage
48	-	V _{SS4}										IOs ground voltage
47	-	V _{DD4}										IOs supply voltage

- At power-up, the PA1/NRST pin is a reset input pin with pull-up. To be used as a general purpose pin (PA1), it can be configured only as output open-drain or push-pull, not as a general purpose input. Refer to Section *Configuring NRST/PA1 pin as general purpose output* in the STM8L15xx and STM8L16xx reference manual (RM0031).
- [] Alternate function remapping option (if the same alternate function is shown twice, it indicates an exclusive choice not a duplication of the function).
- In the 5 V tolerant I/Os, the protection diode to V_{DD} is not implemented.
- A pull-up is applied to PB0 and PB4 during the reset phase. These two pins are input floating after reset release.
- In the open-drain output column, 'T' defines a true open-drain I/O (P-buffer, weak pull-up and protection diode to V_{DD} are not implemented).
- Not in 64-pin version.
- SEG/COM multiplexing available on medium+ and high density devices. SEG signals are available by default (see reference manual for details)"
- The PA0 pin is in input pull-up during the reset phase and after reset release.
- High Sink LED driver capability available on PA0.

System configuration options

As shown in [Table 4: STM8L162x pin description](#), some alternate functions can be remapped on different I/O ports by programming one of the two remapping registers described in the “Routing interface (RI) and system configuration controller” section in the STM8L15xx and STM8L16xx reference manual (RM0031).

5 Memory and register map

5.1 Memory mapping

The memory map is shown in *Figure 5*.

Figure 5. Memory map

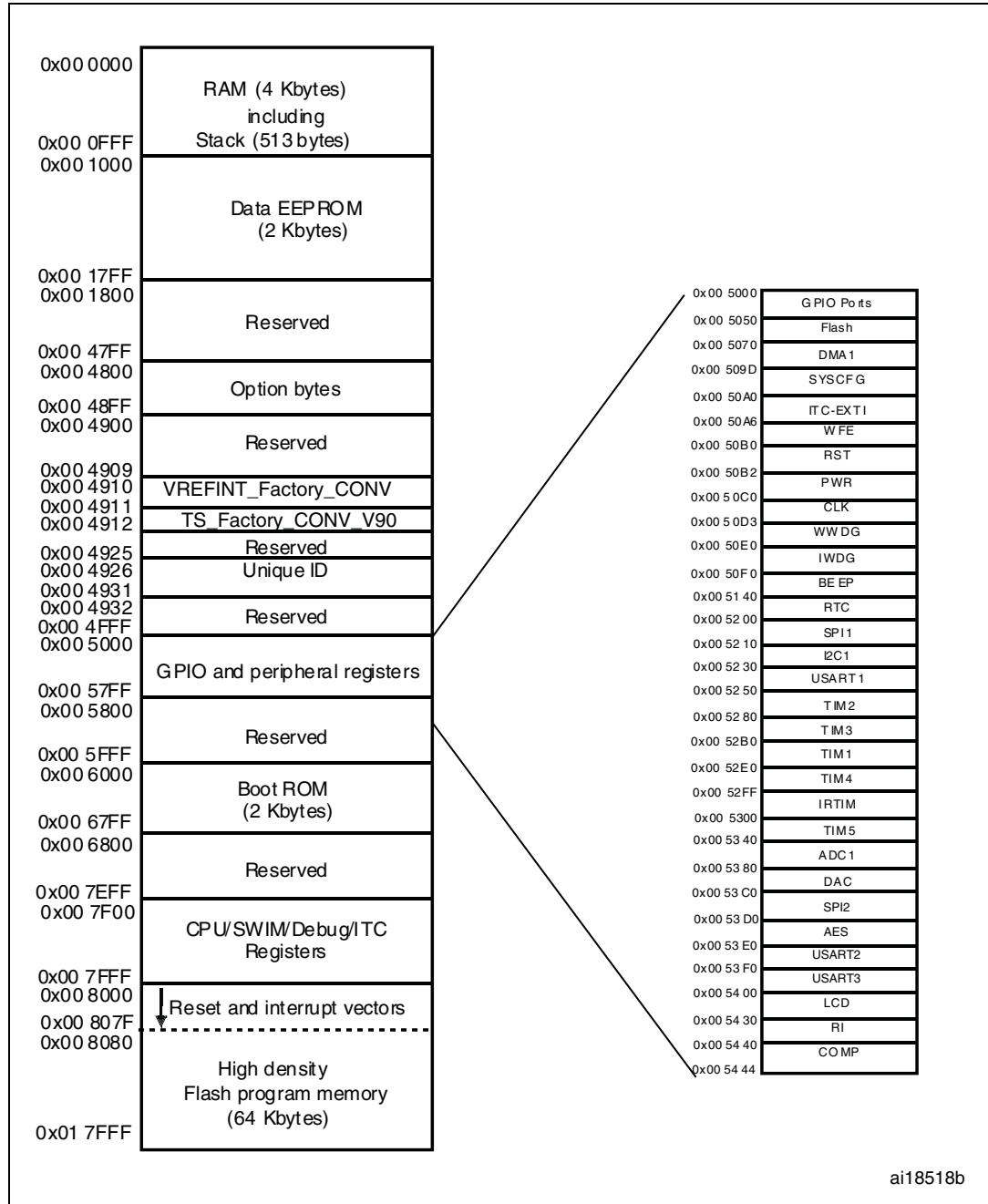

ai18518b

1. Refer to *Table 8* for an overview of hardware register mapping, to *Table 7* for details on I/O port hardware registers, and to *Table 9* for information on CPU/SWIM/debug module controller registers.

Table 5. Flash and RAM boundary addresses

Memory area	Size	Start address	End address
RAM	2 Kbytes	0x00 0000	0x00 07FF
	4 Kbytes	0x00 0000	0x00 0FFF
Flash program memory	32 Kbytes	0x00 8000	0x00 FFFF
	64 Kbytes	0x00 8000	0x01 7FFF

5.2 Register map

Table 6. Factory conversion registers

Address	Block	Register label	Register name	Reset status
0x00 4910	-	VREFINT_Factory_CONV ⁽¹⁾	Internal reference voltage factory conversion	0xXX
0x00 4911	-	TS_Factory_CONV_V90 ⁽²⁾	Temperature sensor output voltage	0xXX

1. The VREFINT_Factory_CONV byte represents the 8 LSB of the result of the VREFINT 12-bit ADC conversion performed in factory. The 2 MSB have a fixed value: 0x6.

2. The TS_Factory_CONV_V90 byte represents the 8 LSB of the result of the V90 12-bit ADC conversion performed in factory. The 2 MSB have a fixed value: 0x3.

Table 7. I/O port hardware register map

Address	Block	Register label	Register name	Reset status
0x00 5000	Port A	PA_ODR	Port A data output latch register	0x00
0x00 5001		PA_IDR	Port A input pin value register	0xXX
0x00 5002		PA_DDR	Port A data direction register	0x00
0x00 5003		PA_CR1	Port A control register 1	0x01
0x00 5004		PA_CR2	Port A control register 2	0x00
0x00 5005	Port B	PB_ODR	Port B data output latch register	0x00
0x00 5006		PB_IDR	Port B input pin value register	0xXX
0x00 5007		PB_DDR	Port B data direction register	0x00
0x00 5008		PB_CR1	Port B control register 1	0x00
0x00 5009		PB_CR2	Port B control register 2	0x00
0x00 500A	Port C	PC_ODR	Port C data output latch register	0x00
0x00 500B		PC_IDR	Port C input pin value register	0xXX
0x00 500C		PC_DDR	Port C data direction register	0x00
0x00 500D		PC_CR1	Port C control register 1	0x00
0x00 500E		PC_CR2	Port C control register 2	0x00

Table 7. I/O port hardware register map (continued)

Address	Block	Register label	Register name	Reset status
0x00 500F	Port D	PD_ODR	Port D data output latch register	0x00
0x00 5010		PD_IDR	Port D input pin value register	0xXX
0x00 5011		PD_DDR	Port D data direction register	0x00
0x00 5012		PD_CR1	Port D control register 1	0x00
0x00 5013		PD_CR2	Port D control register 2	0x00
0x00 5014	Port E	PE_ODR	Port E data output latch register	0x00
0x00 5015		PE_IDR	Port E input pin value register	0xXX
0x00 5016		PE_DDR	Port E data direction register	0x00
0x00 5017		PE_CR1	Port E control register 1	0x00
0x00 5018		PE_CR2	Port E control register 2	0x00
0x00 5019	Port F	PF_ODR	Port F data output latch register	0x00
0x00 501A		PF_IDR	Port F input pin value register	0xXX
0x00 501B		PF_DDR	Port F data direction register	0x00
0x00 501C		PF_CR1	Port F control register 1	0x00
0x00 501D		PF_CR2	Port F control register 2	0x00
0x00 501E	Port G	PG_ODR	Port G data output latch register	0x00
0x00 501F		PG_IDR	Port G input pin value register	0xXX
0x00 5020		PG_DDR	Port G data direction register	0x00
0x00 5021		PG_CR1	Port G control register 1	0x00
0x00 5022		PG_CR2	Port G control register 2	0x00
0x00 5023	Port H	PH_ODR	Port H data output latch register	0x00
0x00 5024		PH_IDR	Port H input pin value register	0xXX
0x00 5025		PH_DDR	Port H data direction register	0x00
0x00 5026		PH_CR1	Port H control register 1	0x00
0x00 5027		PH_CR2	Port H control register 2	0x00
0x00 5028	Port I	PI_ODR	Port I data output latch register	0x00
0x00 5029		PI_IDR	Port I input pin value register	0xXX
0x00 502A		PI_DDR	Port I data direction register	0x00
0x00 502B		PI_CR1	Port I control register 1	0x00
0x00 502C		PI_CR2	Port I control register 2	0x00

Table 8. General hardware register map

Address	Block	Register label	Register name	Reset status
0x00 502E to 0x00 5049	Reserved area (44 bytes)			
0x00 5050	Flash	FLASH_CR1	Flash control register 1	0x00
0x00 5051		FLASH_CR2	Flash control register 2	0x00
0x00 5052		FLASH_PUKR	Flash program memory unprotection key register	0x00
0x00 5053		FLASH_DUKR	Data EEPROM unprotection key register	0x00
0x00 5054		FLASH_IAPSR	Flash in-application programming status register	0x00
0x00 5055 to 0x00 506F	Reserved area (27 bytes)			
0x00 5070	DMA1	DMA1_GCSR	DMA1 global configuration & status register	0xFC
0x00 5071		DMA1_GIR1	DMA1 global interrupt register 1	0x00
0x00 5072 to 0x00 5074		Reserved area (3 bytes)		
0x00 5075		DMA1_C0CR	DMA1 channel 0 configuration register	0x00
0x00 5076		DMA1_C0SPR	DMA1 channel 0 status & priority register	0x00
0x00 5077		DMA1_C0NDTR	DMA1 number of data to transfer register (channel 0)	0x00
0x00 5078		DMA1_C0PARH	DMA1 peripheral address high register (channel 0)	0x52
0x00 5079		DMA1_C0PARL	DMA1 peripheral address low register (channel 0)	0x00
0x00 507A		Reserved area (1 byte)		
0x00 507B		DMA1_C0M0ARH	DMA1 memory 0 address high register (channel 0)	0x00
0x00 507C		DMA1_C0M0ARL	DMA1 memory 0 address low register (channel 0)	0x00
0x00 507D to 0x00 507E		Reserved area (2 bytes)		
0x00 507F		DMA1_C1CR	DMA1 channel 1 configuration register	0x00
0x00 5080		DMA1_C1SPR	DMA1 channel 1 status & priority register	0x00
0x00 5081		DMA1_C1NDTR	DMA1 number of data to transfer register (channel 1)	0x00
0x00 5082		DMA1_C1PARH	DMA1 peripheral address high register (channel 1)	0x52

Table 8. General hardware register map (continued)

Address	Block	Register label	Register name	Reset status	
0x00 5083	DMA1	DMA1_C1PARL	DMA1 peripheral address low register (channel 1)	0x00	
0x00 5084	Reserved area (1 byte)				
0x00 5085	DMA1	DMA1_C1M0ARH	DMA1 memory 0 address high register (channel 1)	0x00	
0x00 5086		DMA1_C1M0ARL	DMA1 memory 0 address low register (channel 1)	0x00	
0x00 5087 0x00 5088	Reserved area (2 bytes)				
0x00 5089	DMA1	DMA1_C2CR	DMA1 channel 2 configuration register	0x00	
0x00 508A		DMA1_C2SPR	DMA1 channel 2 status & priority register	0x00	
0x00 508B		DMA1_C2NDTR	DMA1 number of data to transfer register (channel 2)	0x00	
0x00 508C		DMA1_C2PARH	DMA1 peripheral address high register (channel 2)	0x52	
0x00 508D		DMA1_C2PARL	DMA1 peripheral address low register (channel 2)	0x00	
0x00 508E		Reserved area (1 byte)			
0x00 508F		DMA1_C2M0ARH	DMA1 memory 0 address high register (channel 2)	0x00	
0x00 5090		DMA1_C2M0ARL	DMA1 memory 0 address low register (channel 2)	0x00	
0x00 5091 0x00 5092		Reserved area (2 bytes)			
0x00 5093		DMA1	DMA1_C3CR	DMA1 channel 3 configuration register	0x00
0x00 5094	DMA1_C3SPR		DMA1 channel 3 status & priority register	0x00	
0x00 5095	DMA1_C3NDTR		DMA1 number of data to transfer register (channel 3)	0x00	
0x00 5096	DMA1_C3PARH_C3M1ARH		DMA1 peripheral address high register (channel 3)	0x40	
0x00 5097	DMA1_C3PARL_C3M1ARL		DMA1 peripheral address low register (channel 3)	0x00	
0x00 5098	DMA_C3M0EAR		DMA channel 3 memory 0 extended address register	0x00	
0x00 5099	DMA1_C3M0ARH		DMA1 memory 0 address high register (channel 3)	0x00	
0x00 509A	DMA1_C3M0ARL		DMA1 memory 0 address low register (channel 3)	0x00	
0x00 509B to 0x00 509C	Reserved area (3 bytes)				

Table 8. General hardware register map (continued)

Address	Block	Register label	Register name	Reset status
0x00 509D	SYSCFG	SYSCFG_RMPCR3	Remapping register 3	0x00
0x00 509E		SYSCFG_RMPCR1	Remapping register 1	0x00
0x00 509F		SYSCFG_RMPCR2	Remapping register 2	0x00
0x00 50A0	ITC - EXTI	EXTI_CR1	External interrupt control register 1	0x00
0x00 50A1		EXTI_CR2	External interrupt control register 2	0x00
0x00 50A2		EXTI_CR3	External interrupt control register 3	0x00
0x00 50A3		EXTI_SR1	External interrupt status register 1	0x00
0x00 50A4		EXTI_SR2	External interrupt status register 2	0x00
0x00 50A5		EXTI_CONF1	External interrupt port select register 1	0x00
0x00 50A6	WFE	WFE_CR1	WFE control register 1	0x00
0x00 50A7		WFE_CR2	WFE control register 2	0x00
0x00 50A8		WFE_CR3	WFE control register 3	0x00
0x00 50A9		WFE_CR4	WFE control register 4	0x00
0x00 50AA	ITC - EXTI	EXTI_CR4	External interrupt control register 4	0x00
0x00 50AB		EXTI_CONF2	External interrupt port select register 2	0x00
0x00 50A9 to 0x00 50AF	Reserved area (7 bytes)			
0x00 50B0	RST	RST_CR	Reset control register	0x00
0x00 50B1		RST_SR	Reset status register	0x01
0x00 50B2	PWR	PWR_CSR1	Power control and status register 1	0x00
0x00 50B3		PWR_CSR2	Power control and status register 2	0x00
0x00 50B4 to 0x00 50BF	Reserved area (12 bytes)			
0x00 50C0	CLK	CLK_CKDIVR	Clock master divider register	0x03
0x00 50C1		CLK_CRTCR	Clock RTC register	0x00 ⁽¹⁾
0x00 50C2		CLK_ICKCR	Internal clock control register	0x11
0x00 50C3		CLK_PCKENR1	Peripheral clock gating register 1	0x00
0x00 50C4		CLK_PCKENR2	Peripheral clock gating register 2	0x00
0x00 50C5		CLK_CCOR	Configurable clock control register	0x00
0x00 50C6		CLK_ECKCR	External clock control register	0x00
0x00 50C7		CLK_SCSR	System clock status register	0x01
0x00 50C8		CLK_SWR	System clock switch register	0x01
0x00 50C9		CLK_SWCR	Clock switch control register	0xX0

Table 8. General hardware register map (continued)

Address	Block	Register label	Register name	Reset status
0x00 50CA	CLK	CLK_CSSR	Clock security system register	0x00
0x00 50CB		CLK_CBEEPR	Clock BEEP register	0x00
0x00 50CC		CLK_HSICALR	HSI calibration register	0xXX
0x00 50CD		CLK_HSITRIMR	HSI clock calibration trimming register	0x00
0x00 50CE		CLK_HSIUNLCKR	HSI unlock register	0x00
0x00 50CF		CLK_REGCSR	Main regulator control status register	0bxx11 100X
0x00 50D0		CLK_PCKENR3	Peripheral clock gating register 3	0x00
0x00 50D1 to 0x00 50D2	Reserved area (2 bytes)			
0x00 50D3	WWDG	WWDG_CR	WWDG control register	0x7F
0x00 50D4		WWDG_WR	WWDG window register	0x7F
0x00 50D5 to 00 50DF	Reserved area (11 bytes)			
0x00 50E0	IWDG	IWDG_KR	IWDG key register	0xXX
0x00 50E1		IWDG_PR	IWDG prescaler register	0x00
0x00 50E2		IWDG_RLR	IWDG reload register	0xFF
0x00 50E3 to 0x00 50EF	Reserved area (13 bytes)			
0x00 50F0	BEEP	BEEP_CSR1	BEEP control/status register 1	0x00
0x00 50F1 0x00 50F2		Reserved area (2 bytes)		
0x00 50F3		BEEP_CSR2	BEEP control/status register 2	0x1F
0x00 50F4 to 0x00 513F	Reserved area (76 bytes)			
0x00 5140	RTC	RTC_TR1	Time register 1	0x00
0x00 5141		RTC_TR2	Time register 2	0x00
0x00 5142		RTC_TR3	Time register 3	0x00
0x00 5143	Reserved area (1 byte)			
0x00 5144	RTC	RTC_DR1	Date register 1	0x01
0x00 5145		RTC_DR2	Date register 2	0x21
0x00 5146		RTC_DR3	Date register 3	0x00
0x00 5147	Reserved area (1 byte)			

Table 8. General hardware register map (continued)

Address	Block	Register label	Register name	Reset status
0x00 5148	RTC	RTC_CR1	Control register 1	0x00 ⁽¹⁾
0x00 5149		RTC_CR2	Control register 2	0x00 ⁽¹⁾
0x00 514A		RTC_CR3	Control register 3	0x00 ⁽¹⁾
0x00 514B		Reserved area (1 byte)		
0x00 514C		RTC_ISR1	Initialization and status register 1	0x01
0x00 514D		RTC_ISR2	Initialization and Status register 2	0x00
0x00 514E 0x00 514F		Reserved area (2 bytes)		
0x00 5150	RTC	RTC_SPRERH	Synchronous prescaler register high	0x00 ⁽¹⁾
0x00 5151		RTC_SPRERL	Synchronous prescaler register low	0xFF ⁽¹⁾
0x00 5152		RTC_APRER	Asynchronous prescaler register	0x7F ⁽¹⁾
0x00 5153	Reserved area (1 byte)			
0x00 5154	RTC	RTC_WUTRH	Wakeup timer register high	0xFF ⁽¹⁾
0x00 5155		RTC_WUTRL	Wakeup timer register low	0xFF ⁽¹⁾
0x00 5156	Reserved area (1 byte)			
0x00 5157	RTC	RTC_SSRL	Subsecond register low	0x00
0x00 5158		RTC_SSRH	Subsecond register high	0x00
0x00 5159		RTC_WPR	Write protection register	0x00
0x00 5158		RTC_SSRH	Subsecond register high	0x00
0x00 5159		RTC_WPR	Write protection register	0x00
0x00 515A		RTC_SHIFTRH	Shift register high	0x00
0x00 515B		RTC_SHIFTRL	Shift register low	0x00
0x00 515C		RTC_ALRMAR1	Alarm A register 1	0x00 ⁽¹⁾
0x00 515D		RTC_ALRMAR2	Alarm A register 2	0x00 ⁽¹⁾
0x00 515E		RTC_ALRMAR3	Alarm A register 3	0x00 ⁽¹⁾
0x00 515F		RTC_ALRMAR4	Alarm A register 4	0x00 ⁽¹⁾
0x00 5160 to 0x00 5163		Reserved area (4 bytes)		
0x00 5164	RTC	RTC_ALRMASRH	Alarm A subsecond register high	0x00 ⁽¹⁾
0x00 5165		RTC_ALRMASRL	Alarm A subsecond register low	0x00 ⁽¹⁾
0x00 5166		RTC_ALRMASMSKR	Alarm A masking register	0x00 ⁽¹⁾
0x00 5167 to 0x00 5169	Reserved area (3 bytes)			

Table 8. General hardware register map (continued)

Address	Block	Register label	Register name	Reset status
0x00 516A	RTC	RTC_CALRH	Calibration register high	0x00 ⁽¹⁾
0x00 516B		RTC_CALRL	Calibration register low	0x00 ⁽¹⁾
0x00 516C		RTC_TCR1	Tamper control register 1	0x00 ⁽¹⁾
0x00 516D		RTC_TCR2	Tamper control register 2	0x00 ⁽¹⁾
0x00 516E to 0x00 518A	Reserved area			
0x00 5190	CSSLSE	CSSLSE_CSR	CSS on LSE control and status register	0x00 ⁽¹⁾
0x00 519A to 0x00 51FF	Reserved area			
0x00 5200	SPI1	SPI1_CR1	SPI1 control register 1	0x00
0x00 5201		SPI1_CR2	SPI1 control register 2	0x00
0x00 5202		SPI1_ICR	SPI1 interrupt control register	0x00
0x00 5203		SPI1_SR	SPI1 status register	0x02
0x00 5204		SPI1_DR	SPI1 data register	0x00
0x00 5205		SPI1_CRCPR	SPI1 CRC polynomial register	0x07
0x00 5206		SPI1_RXCR	SPI1 Rx CRC register	0x00
0x00 5207		SPI1_TXCR	SPI1 Tx CRC register	0x00
0x00 5208 to 0x00 520F	Reserved area (8 bytes)			
0x00 5210	I2C1	I2C1_CR1	I2C1 control register 1	0x00
0x00 5211		I2C1_CR2	I2C1 control register 2	0x00
0x00 5212		I2C1_FREQR	I2C1 frequency register	0x00
0x00 5213		I2C1_OARL	I2C1 own address register low	0x00
0x00 5214		I2C1_OARH	I2C1 own address register high	0x00
0x00 5215		I2C1_OARH	I2C1 own address register for dual mode	0x00
0x00 5216		I2C1_DR	I2C1 data register	0x00
0x00 5217		I2C1_SR1	I2C1 status register 1	0x00
0x00 5218		I2C1_SR2	I2C1 status register 2	0x00
0x00 5219		I2C1_SR3	I2C1 status register 3	0x0X
0x00 521A		I2C1_ITR	I2C1 interrupt control register	0x00
0x00 521B		I2C1_CCRL	I2C1 clock control register low	0x00
0x00 521C		I2C1_CCRH	I2C1 clock control register high	0x00
0x00 521D		I2C1_TRISER	I2C1 TRISE register	0x02
0x00 521E		I2C1_PECR	I2C1 packet error checking register	0x00

Table 8. General hardware register map (continued)

Address	Block	Register label	Register name	Reset status
0x00 521F to 0x00 522F	Reserved area (17 bytes)			
0x00 5230	USART1	USART1_SR	USART1 status register	0xC0
0x00 5231		USART1_DR	USART1 data register	0xFF
0x00 5232		USART1_BRR1	USART1 baud rate register 1	0x00
0x00 5233		USART1_BRR2	USART1 baud rate register 2	0x00
0x00 5234		USART1_CR1	USART1 control register 1	0x00
0x00 5235		USART1_CR2	USART1 control register 2	0x00
0x00 5236		USART1_CR3	USART1 control register 3	0x00
0x00 5237		USART1_CR4	USART1 control register 4	0x00
0x00 5238		USART1_CR5	USART1 control register 5	0x00
0x00 5239		USART1_GTR	USART1 guard time register	0x00
0x00 523A		USART1_PSCR	USART1 prescaler register	0x00
0x00 523B to 0x00 524F		Reserved area (21 bytes)		
0x00 5250	TIM2	TIM2_CR1	TIM2 control register 1	0x00
0x00 5251		TIM2_CR2	TIM2 control register 2	0x00
0x00 5252		TIM2_SMCR	TIM2 Slave mode control register	0x00
0x00 5253		TIM2_ETR	TIM2 external trigger register	0x00
0x00 5254		TIM2_DER	TIM2 DMA1 request enable register	0x00
0x00 5255		TIM2_IER	TIM2 interrupt enable register	0x00
0x00 5256		TIM2_SR1	TIM2 status register 1	0x00
0x00 5257		TIM2_SR2	TIM2 status register 2	0x00
0x00 5258		TIM2_EGR	TIM2 event generation register	0x00
0x00 5259		TIM2_CCMR1	TIM2 capture/compare mode register 1	0x00
0x00 525A		TIM2_CCMR2	TIM2 capture/compare mode register 2	0x00
0x00 525B		TIM2_CCER1	TIM2 capture/compare enable register 1	0x00
0x00 525C		TIM2_CNTRH	TIM2 counter high	0x00
0x00 525D		TIM2_CNTRL	TIM2 counter low	0x00
0x00 525E		TIM2_PSCR	TIM2 prescaler register	0x00
0x00 525F		TIM2_ARRH	TIM2 auto-reload register high	0xFF
0x00 5260		TIM2_ARRL	TIM2 auto-reload register low	0xFF
0x00 5261		TIM2_CCR1H	TIM2 capture/compare register 1 high	0x00

Table 8. General hardware register map (continued)

Address	Block	Register label	Register name	Reset status
0x00 5262	TIM2	TIM2_CCR1L	TIM2 capture/compare register 1 low	0x00
0x00 5263		TIM2_CCR2H	TIM2 capture/compare register 2 high	0x00
0x00 5264		TIM2_CCR2L	TIM2 capture/compare register 2 low	0x00
0x00 5265		TIM2_BKR	TIM2 break register	0x00
0x00 5266		TIM2_OISR	TIM2 output idle state register	0x00
0x00 5267 to 0x00 527F	Reserved area (25 bytes)			
0x00 5280	TIM3	TIM3_CR1	TIM3 control register 1	0x00
0x00 5281		TIM3_CR2	TIM3 control register 2	0x00
0x00 5282		TIM3_SMCR	TIM3 Slave mode control register	0x00
0x00 5283		TIM3_ETR	TIM3 external trigger register	0x00
0x00 5284		TIM3_DER	TIM3 DMA1 request enable register	0x00
0x00 5285		TIM3_IER	TIM3 interrupt enable register	0x00
0x00 5286		TIM3_SR1	TIM3 status register 1	0x00
0x00 5287		TIM3_SR2	TIM3 status register 2	0x00
0x00 5288		TIM3_EGR	TIM3 event generation register	0x00
0x00 5289		TIM3_CCMR1	TIM3 Capture/Compare mode register 1	0x00
0x00 528A		TIM3_CCMR2	TIM3 Capture/Compare mode register 2	0x00
0x00 528B		TIM3_CCER1	TIM3 Capture/Compare enable register 1	0x00
0x00 528C		TIM3_CNTRH	TIM3 counter high	0x00
0x00 528D		TIM3_CNTRL	TIM3 counter low	0x00
0x00 528E		TIM3_PSCR	TIM3 prescaler register	0x00
0x00 528F		TIM3_ARRH	TIM3 Auto-reload register high	0xFF
0x00 5290		TIM3_ARRL	TIM3 Auto-reload register low	0xFF
0x00 5291		TIM3_CCR1H	TIM3 Capture/Compare register 1 high	0x00
0x00 5292		TIM3_CCR1L	TIM3 Capture/Compare register 1 low	0x00
0x00 5293		TIM3_CCR2H	TIM3 Capture/Compare register 2 high	0x00
0x00 5294		TIM3_CCR2L	TIM3 Capture/Compare register 2 low	0x00
0x00 5295		TIM3_BKR	TIM3 break register	0x00
0x00 5296		TIM3_OISR	TIM3 output idle state register	0x00
0x00 5297 to 0x00 52AF	Reserved area (25 bytes)			

Table 8. General hardware register map (continued)

Address	Block	Register label	Register name	Reset status
0x00 52B0	TIM1	TIM1_CR1	TIM1 control register 1	0x00
0x00 52B1		TIM1_CR2	TIM1 control register 2	0x00
0x00 52B2		TIM1_SMCR	TIM1 Slave mode control register	0x00
0x00 52B3		TIM1_ETR	TIM1 external trigger register	0x00
0x00 52B4		TIM1_DER	TIM1 DMA1 request enable register	0x00
0x00 52B5		TIM1_IER	TIM1 Interrupt enable register	0x00
0x00 52B6		TIM1_SR1	TIM1 status register 1	0x00
0x00 52B7		TIM1_SR2	TIM1 status register 2	0x00
0x00 52B8		TIM1_EGR	TIM1 event generation register	0x00
0x00 52B9		TIM1_CCMR1	TIM1 Capture/Compare mode register 1	0x00
0x00 52BA		TIM1_CCMR2	TIM1 Capture/Compare mode register 2	0x00
0x00 52BB		TIM1_CCMR3	TIM1 Capture/Compare mode register 3	0x00
0x00 52BC		TIM1_CCMR4	TIM1 Capture/Compare mode register 4	0x00
0x00 52BD		TIM1_CCER1	TIM1 Capture/Compare enable register 1	0x00
0x00 52BE		TIM1_CCER2	TIM1 Capture/Compare enable register 2	0x00
0x00 52BF		TIM1_CNTRH	TIM1 counter high	0x00
0x00 52C0		TIM1_CNTRL	TIM1 counter low	0x00
0x00 52C1		TIM1_PSCRH	TIM1 prescaler register high	0x00
0x00 52C2		TIM1_PSCRL	TIM1 prescaler register low	0x00
0x00 52C3		TIM1_ARRH	TIM1 Auto-reload register high	0xFF
0x00 52C4		TIM1_ARRL	TIM1 Auto-reload register low	0xFF
0x00 52C5		TIM1_RCR	TIM1 Repetition counter register	0x00
0x00 52C6		TIM1_CCR1H	TIM1 Capture/Compare register 1 high	0x00
0x00 52C7		TIM1_CCR1L	TIM1 Capture/Compare register 1 low	0x00
0x00 52C8		TIM1_CCR2H	TIM1 Capture/Compare register 2 high	0x00
0x00 52C9		TIM1_CCR2L	TIM1 Capture/Compare register 2 low	0x00
0x00 52CA		TIM1_CCR3H	TIM1 Capture/Compare register 3 high	0x00
0x00 52CB		TIM1_CCR3L	TIM1 Capture/Compare register 3 low	0x00
0x00 52CC		TIM1_CCR4H	TIM1 Capture/Compare register 4 high	0x00
0x00 52CD		TIM1_CCR4L	TIM1 Capture/Compare register 4 low	0x00
0x00 52CE		TIM1_BKR	TIM1 break register	0x00
0x00 52CF		TIM1_DTR	TIM1 dead-time register	0x00
0x00 52D0		TIM1_OISR	TIM1 output idle state register	0x00
0x00 52D1		TIM1_DCR1	DMA1 control register 1	0x00

Table 8. General hardware register map (continued)

Address	Block	Register label	Register name	Reset status
0x00 52D2	TIM1	TIM1_DCR2	TIM1 DMA1 control register 2	0x00
0x00 52D3		TIM1_DMA1R	TIM1 DMA1 address for burst mode	0x00
0x00 52D4 to 0x00 52DF	Reserved area (12 bytes)			
0x00 52E0	TIM4	TIM4_CR1	TIM4 control register 1	0x00
0x00 52E1		TIM4_CR2	TIM4 control register 2	0x00
0x00 52E2		TIM4_SMCR	TIM4 Slave mode control register	0x00
0x00 52E3		TIM4_DER	TIM4 DMA1 request enable register	0x00
0x00 52E4		TIM4_IER	TIM4 Interrupt enable register	0x00
0x00 52E5		TIM4_SR1	TIM4 status register 1	0x00
0x00 52E6		TIM4_EGR	TIM4 Event generation register	0x00
0x00 52E7		TIM4_CNTR	TIM4 counter	0x00
0x00 52E8		TIM4_PSCR	TIM4 prescaler register	0x00
0x00 52E9		TIM4_ARR	TIM4 Auto-reload register	0x00
0x00 52EA to 0x00 52FE		Reserved area (21 bytes)		
0x00 52FF	IRTIM	IR_CR	Infrared control register	0x00
0x00 5300	TIM5	TIM5_CR1	TIM5 control register 1	0x00
0x00 5301		TIM5_CR2	TIM5 control register 2	0x00
0x00 5302		TIM5_SMCR	TIM5 Slave mode control register	0x00
0x00 5303		TIM5_ETR	TIM5 external trigger register	0x00
0x00 5304		TIM5_DER	TIM5 DMA1 request enable register	0x00
0x00 5305		TIM5_IER	TIM5 interrupt enable register	0x00
0x00 5306		TIM5_SR1	TIM5 status register 1	0x00
0x00 5307		TIM5_SR2	TIM5 status register 2	0x00
0x00 5308		TIM5_EGR	TIM5 event generation register	0x00
0x00 5309		TIM5_CCMR1	TIM5 Capture/Compare mode register 1	0x00
0x00 530A		TIM5_CCMR2	TIM5 Capture/Compare mode register 2	0x00
0x00 530B		TIM5_CCER1	TIM5 Capture/Compare enable register 1	0x00
0x00 530C		TIM5_CNTRH	TIM5 counter high	0x00
0x00 530D		TIM5_CNTRL	TIM5 counter low	0x00
0x00 530E		TIM5_PSCR	TIM5 prescaler register	0x00
0x00 530F		TIM5_ARRH	TIM5 Auto-reload register high	0xFF

Table 8. General hardware register map (continued)

Address	Block	Register label	Register name	Reset status
0x00 5310	TIM5	TIM5_ARRL	TIM5 Auto-reload register low	0xFF
0x00 5311		TIM5_CCR1H	TIM5 Capture/Compare register 1 high	0x00
0x00 5312		TIM5_CCR1L	TIM5 Capture/Compare register 1 low	0x00
0x00 5313		TIM5_CCR2H	TIM5 Capture/Compare register 2 high	0x00
0x00 5314		TIM5_CCR2L	TIM5 Capture/Compare register 2 low	0x00
0x00 5315		TIM5_BKR	TIM5 break register	0x00
0x00 5316		TIM5_OISR	TIM5 output idle state register	0x00
0x00 5317 to 0x00 533F		Reserved area		
0x00 5340	ADC1	ADC1_CR1	ADC1 configuration register 1	0x00
0x00 5341		ADC1_CR2	ADC1 configuration register 2	0x00
0x00 5342		ADC1_CR3	ADC1 configuration register 3	0x1F
0x00 5343		ADC1_SR	ADC1 status register	0x00
0x00 5344		ADC1_DRH	ADC1 data register high	0x00
0x00 5345		ADC1_DRL	ADC1 data register low	0x00
0x00 5346		ADC1_HTRH	ADC1 high threshold register high	0x0F
0x00 5347		ADC1_HTRL	ADC1 high threshold register low	0xFF
0x00 5348		ADC1_LTRH	ADC1 low threshold register high	0x00
0x00 5349		ADC1_LTRL	ADC1 low threshold register low	0x00
0x00 534A		ADC1_SQR1	ADC1 channel sequence 1 register	0x00
0x00 534B		ADC1_SQR2	ADC1 channel sequence 2 register	0x00
0x00 534C		ADC1_SQR3	ADC1 channel sequence 3 register	0x00
0x00 534D		ADC1_SQR4	ADC1 channel sequence 4 register	0x00
0x00 534E		ADC1_TRIGR1	ADC1 trigger disable 1	0x00
0x00 534F		ADC1_TRIGR2	ADC1 trigger disable 2	0x00
0x00 5350		ADC1_TRIGR3	ADC1 trigger disable 3	0x00
0x00 5351		ADC1_TRIGR4	ADC1 trigger disable 4	0x00
0x00 5352 to 0x00 537F	Reserved area (46 bytes)			

Table 8. General hardware register map (continued)

Address	Block	Register label	Register name	Reset status
0x00 5380	DAC	DAC_CH1CR1	DAC channel 1 control register 1	0x00
0x00 5381		DAC_CH1CR2	DAC channel 1 control register 2	0x00
0x00 5382		DAC_CH2CR1	DAC channel 2 control register 1	0x00
0x00 5383		DAC_CH2CR2	DAC channel 2 control register 2	0x00
0x00 5384		DAC_SWTRIG	DAC software trigger register	0x00
0x00 5385		DAC_SR	DAC status register	0x00
0x00 5386 to 0x00 5387		Reserved area (2 bytes)		
0x00 5388	DAC	DAC_CH1RDHRH	DAC channel 1 right aligned data holding register high	0x00
0x00 5389		DAC_CH1RDHRL	DAC channel 1 right aligned data holding register low	0x00
0x00 538A to 0x00 538B	Reserved area (2 bytes)			
0x00 538C	DAC	DAC_CH1LDHRH	DAC channel 1 left aligned data holding register high	0x00
0x00 538D	DAC	DAC_CH1LDHRL	DAC channel 1 left aligned data holding register low	0x00
0x00 538E to 0x00 538F	Reserved area (2 bytes)			
0x00 5390	DAC	DAC_CH1DHR8	DAC channel 1 8-bit data holding register	0x00
0x00 5391 to 0x00 5393	Reserved area (3 bytes)			
0x00 5394	DAC	DAC_CH2RDHRH	DAC channel 2 right aligned data holding register high	0x00
0x00 5395		DAC_CH2RDHRL	DAC channel 2 right aligned data holding register low	0x00
0x00 5396 to 0x00 5397	Reserved area (2 bytes)			
0x00 5398	DAC	DAC_CH2LDHRH	DAC channel 2 left aligned data holding register high	0x00
0x00 5399		DAC_CH2LDHRL	DAC channel 2 left aligned data holding register low	0x00
0x00 539A to 0x00 539B	Reserved area (2 bytes)			
0x00 539C	DAC	DAC_CH2DHR8	DAC channel 2 8-bit data holding register	0x00
0x00 539D to 0x00 539F	Reserved area (3 bytes)			

Table 8. General hardware register map (continued)

Address	Block	Register label	Register name	Reset status	
0x00 53A0	DAC	DAC_DCH1RDHRH	DAC channel 1 right aligned data holding register high	0x00	
0x00 53A1		DAC_DCH1RDHRL	DAC channel 1 right aligned data holding register low	0x00	
0x00 53A2 to 0x00 53AB	Reserved area (3 bytes)				
0x00 53AC	DAC	DAC_DORH	DAC data output register high	0x00	
0x00 53AD		DAC_DORL	DAC data output register low	0x00	
0x00 53A2		DAC_DCH2RDHRH	DAC channel 2 right aligned data holding register high	0x00	
0x00 53A3		DAC_DCH2RDHRL	DAC channel 2 right aligned data holding register low	0x00	
0x00 53A4		DAC_DCH1LDHRH	DAC channel 1 left aligned data holding register high	0x00	
0x00 53A5		DAC_DCH1LDHRL	DAC channel 1 left aligned data holding register low	0x00	
0x00 53A6		DAC_DCH2LDHRH	DAC channel 2 left aligned data holding register high	0x00	
0x00 53A7		DAC_DCH2LDHRL	DAC channel 2 left aligned data holding register low	0x00	
0x00 53A8		DAC_DCH1DHR8	DAC channel 1 8-bit mode data holding register	0x00	
0x00 53A9		DAC_DCH2DHR8	DAC channel 2 8-bit mode data holding register	0x00	
0x00 53AA to 0x00 53AB		Reserved area (2 bytes)			
0x00 53AC		DAC	DAC_CH1DORH Reset value	DAC channel 1 data output register high	0x00
0x00 53AD	DAC_CH1DORL Reset value		DAC channel 1 data output register low	0x00	
0x00 53AE to 0x00 53AF	Reserved area (2 bytes)				
0x00 53B0	DAC	DAC_CH2DORH Reset value	DAC channel 2 data output register high	0x00	
0x00 53B1		DAC_CH2DORL Reset value	DAC channel 2 data output register low	0x00	
0x00 53B2 to 0x00 53BF	Reserved area				

Table 8. General hardware register map (continued)

Address	Block	Register label	Register name	Reset status
0x00 53C0	SPI2	SPI2_CR1	SPI2 control register 1	0x00
0x00 53C1		SPI2_CR2	SPI2 control register 2	0x00
0x00 53C2		SPI2_ICR	SPI2 interrupt control register	0x00
0x00 53C3		SPI2_SR	SPI2 status register	0x02
0x00 53C4		SPI2_DR	SPI2 data register	0x00
0x00 53C5		SPI2_CRCPR	SPI2 CRC polynomial register	0x07
0x00 53C6		SPI2_RXCR	SPI2 Rx CRC register	0x00
0x00 53C7		SPI2_TXCR	SPI2 Tx CRC register	0x00
0x00 53C8 to 0x00 53CF	Reserved area			
0x00 53D0	AES	AES_CR	AES control register	0x00
0x00 53D1		AES_SR	AES status register	0x00
0x00 53D2		AES_DINR	AES data input register	0x00
0x00 53D3		AES_DOUTR	AES data output register	0x00
0x00 53D4 to 0x00 53DF	Reserved area			
0x00 53E0	USART2	USART2_SR	USART2 status register	0xC0
0x00 53E1		USART2_DR	USART2 data register	0xFF
0x00 53E2		USART2_BRR1	USART2 baud rate register 1	0x00
0x00 53E3		USART2_BRR2	USART2 baud rate register 2	0x00
0x00 53E4		USART2_CR1	USART2 control register 1	0x00
0x00 53E5		USART2_CR2	USART2 control register 2	0x00
0x00 53E6		USART2_CR3	USART2 control register 3	0x00
0x00 53E7		USART2_CR4	USART2 control register 4	0x00
0x00 53E8		USART2_CR5	USART2 control register 5	0x00
0x00 53E9		USART2_GTR	USART2 guard time register	0x00
0x00 53EA		USART2_PSCR	USART2 prescaler register	0x00
0x00 53EB to 0x00 53EF	Reserved area			

Table 8. General hardware register map (continued)

Address	Block	Register label	Register name	Reset status
0x00 53F0	USART3	USART3_SR	USART3 status register	0xC0
0x00 53F1		USART3_DR	USART3 data register	0xFF
0x00 53F2		USART3_BRR1	USART3 baud rate register 1	0x00
0x00 53F3		USART3_BRR2	USART3 baud rate register 2	0x00
0x00 53F4		USART3_CR1	USART3 control register 1	0x00
0x00 53F5		USART3_CR2	USART3 control register 2	0x00
0x00 53F6		USART3_CR3	USART3 control register 3	0x00
0x00 53F7		USART3_CR4	USART3 control register 4	0x00
0x00 53F8		USART3_CR5	USART3 control register 5	0x00
0x00 53F9		USART3_GTR	USART3 guard time register	0x00
0x00 53FA		USART3_PSCR	USART3 prescaler register	0x00
0x00 53FB to 0x00 53FF		Reserved area		
0x00 5400	LCD	LCD_CR1	LCD control register 1	0x00
0x00 5401		LCD_CR2	LCD control register 2	0x00
0x00 5402		LCD_CR3	LCD control register 3	0x00
0x00 5403		LCD_FRQ	LCD frequency selection register	0x00
0x00 5404		LCD_PM0	LCD Port mask register 0	0x00
0x00 5405		LCD_PM1	LCD Port mask register 1	0x00
0x00 5406		LCD_PM2	LCD Port mask register 2	0x00
0x00 5407		LCD_PM3	LCD Port mask register 3	0x00
0x00 5408		LCD_PM4	LCD Port mask register 4	0x00
0x00 5409		LCD_PM5	LCD Port mask register 5	0x00
0x00 540A to 0x00 540B	Reserved area (2 bytes)			

Table 8. General hardware register map (continued)

Address	Block	Register label	Register name	Reset status
0x00 540C	LCD	LCD_RAM0	LCD display memory 0	0x00
0x00 540D		LCD_RAM1	LCD display memory 1	0x00
0x00 540E		LCD_RAM2	LCD display memory 2	0x00
0x00 540F		LCD_RAM3	LCD display memory 3	0x00
0x00 5410		LCD_RAM4	LCD display memory 4	0x00
0x00 5411		LCD_RAM5	LCD display memory 5	0x00
0x00 5412		LCD_RAM6	LCD display memory 6	0x00
0x00 5413		LCD_RAM7	LCD display memory 7	0x00
0x00 5414		LCD_RAM8	LCD display memory 8	0x00
0x00 5415		LCD_RAM9	LCD display memory 9	0x00
0x00 5416		LCD_RAM10	LCD display memory 10	0x00
0x00 5417		LCD_RAM11	LCD display memory 11	0x00
0x00 5418		LCD_RAM12	LCD display memory 12	0x00
0x00 5419		LCD_RAM13	LCD display memory 13	0x00
0x00 541A		LCD_RAM14	LCD display memory 14	0x00
0x00 541B		LCD_RAM15	LCD display memory 15	0x00
0x00 541C		LCD_RAM16	LCD display memory 16	0x00
0x00 541D		LCD_RAM17	LCD display memory 17	0x00
0x00 541E		LCD_RAM18	LCD display memory 18	0x00
0x00 541F		LCD_RAM19	LCD display memory 19	0x00
0x00 5420	LCD_RAM20	LCD display memory 20	0x00	
0x00 5421	LCD	LCD_RAM21	LCD display memory 21	0x00
0x00 5422 to 0x00 542E	Reserved area			
0x00 542F	LCD	LCD_CR4	LCD control register 4	0x00

Table 8. General hardware register map (continued)

Address	Block	Register label	Register name	Reset status
0x00 5430	RI	Reserved area (1 byte)		0x00
0x00 5431		RI_ICR1	Timer input capture routing register 1	0x00
0x00 5432		RI_ICR2	Timer input capture routing register 2	0x00
0x00 5433		RI_IOIR1	I/O input register 1	0xXX
0x00 5434		RI_IOIR2	I/O input register 2	0xXX
0x00 5435		RI_IOIR3	I/O input register 3	0xXX
0x00 5436		RI_IOC MR1	I/O control mode register 1	0x00
0x00 5437		RI_IOC MR2	I/O control mode register 2	0x00
0x00 5438		RI_IOC MR3	I/O control mode register 3	0x00
0x00 5439		RI_IOSR1	I/O switch register 1	0x00
0x00 543A		RI_IOSR2	I/O switch register 2	0x00
0x00 543B		RI_IOSR3	I/O switch register 3	0x00
0x00 543C		RI_IOGCR	I/O group control register	0x3F
0x00 543D		RI_ASCR1	Analog switch register 1	0x00
0x00 543E		RI_ASCR2	Analog switch register 2	0x00
0x00 543F		RI_RCR	Resistor control register 1	0x00
0x00 5440		COMP1/ COMP2	COMP_CSR1	Comparator control and status register 1
0x00 5441	COMP_CSR2		Comparator control and status register 2	0x00
0x00 5442	COMP_CSR3		Comparator control and status register 3	0x00
0x00 5443	COMP_CSR4		Comparator control and status register 4	0x00
0x00 5444	COMP_CSR5		Comparator control and status register 5	0x00

1. These registers are not impacted by a system reset. They are reset at power-on.

Table 9. CPU/SWIM/debug module/interrupt controller registers

Address	Block	Register label	Register name	Reset status
0x00 7F00	CPU ⁽¹⁾	A	Accumulator	0x00
0x00 7F01		PCE	Program counter extended	0x00
0x00 7F02		PCH	Program counter high	0x00
0x00 7F03		PCL	Program counter low	0x00
0x00 7F04		XH	X index register high	0x00
0x00 7F05		XL	X index register low	0x00
0x00 7F06		YH	Y index register high	0x00
0x00 7F07		YL	Y index register low	0x00
0x00 7F08		SPH	Stack pointer high	0x03
0x00 7F09		SPL	Stack pointer low	0xFF
0x00 7F0A		CCR	Condition code register	0x28
0x00 7F0B to 0x00 7F5F			Reserved area (85 bytes)	
0x00 7F60	CPU	CFG_GCR	Global configuration register	0x00
0x00 7F70	ITC-SPR	ITC_SPR1	Interrupt Software priority register 1	0xFF
0x00 7F71		ITC_SPR2	Interrupt Software priority register 2	0xFF
0x00 7F72		ITC_SPR3	Interrupt Software priority register 3	0xFF
0x00 7F73		ITC_SPR4	Interrupt Software priority register 4	0xFF
0x00 7F74		ITC_SPR5	Interrupt Software priority register 5	0xFF
0x00 7F75		ITC_SPR6	Interrupt Software priority register 6	0xFF
0x00 7F76		ITC_SPR7	Interrupt Software priority register 7	0xFF
0x00 7F77		ITC_SPR8	Interrupt Software priority register 8	0xFF
0x00 7F78 to 0x00 7F79		Reserved area (2 bytes)		
0x00 7F80	SWIM	SWIM_CSR	SWIM control status register	0x00
0x00 7F81 to 0x00 7F8F		Reserved area (15 bytes)		

Table 9. CPU/SWIM/debug module/interrupt controller registers (continued)

Address	Block	Register label	Register name	Reset status
0x00 7F90	DM	DM_BK1RE	DM breakpoint 1 register extended byte	0xFF
0x00 7F91		DM_BK1RH	DM breakpoint 1 register high byte	0xFF
0x00 7F92		DM_BK1RL	DM breakpoint 1 register low byte	0xFF
0x00 7F93		DM_BK2RE	DM breakpoint 2 register extended byte	0xFF
0x00 7F94		DM_BK2RH	DM breakpoint 2 register high byte	0xFF
0x00 7F95		DM_BK2RL	DM breakpoint 2 register low byte	0xFF
0x00 7F96		DM_CR1	DM Debug module control register 1	0x00
0x00 7F97		DM_CR2	DM Debug module control register 2	0x00
0x00 7F98		DM_CSR1	DM Debug module control/status register 1	0x10
0x00 7F99		DM_CSR2	DM Debug module control/status register 2	0x00
0x00 7F9A		DM_ENFCTR	DM enable function register	0xFF
0x00 7F9B to 0x00 7F9F		Reserved area (5 bytes)		

1. Accessible by debug module only

6 Interrupt vector mapping

Table 10. Interrupt mapping

IRQ No.	Source block	Description	Wakeup from Halt mode	Wakeup from Active-halt mode	Wakeup from Wait (WFI mode)	Wakeup from Wait (WFE mode) ⁽¹⁾	Vector address
	RESET	Reset	Yes	Yes	Yes	Yes	0x00 8000
	TRAP	Software interrupt	-	-	-	-	0x00 8004
0	TLI ⁽²⁾	External Top level Interrupt	-	-	-	-	0x00 8008
1	FLASH	EOP/WR_PG_DIS	-	-	Yes	Yes ⁽³⁾	0x00 800C
2	DMA1 0/1	DMA1 channels 0/1	-	-	Yes	Yes ⁽³⁾	0x00 8010
3	DMA1 2/3	DMA1 channels 2/3	-	-	Yes	Yes ⁽³⁾	0x00 8014
4	RTC/LSE_CSS	RTC alarm interrupt/LSE CSS interrupt	Yes	Yes	Yes	Yes	0x00 8018
5	EXTI E/F/PVD ⁽⁴⁾	PortE/F interrupt/PVD interrupt	Yes	Yes	Yes	Yes ⁽³⁾	0x00 801C
6	EXTIB/G	External interrupt port B/G	Yes	Yes	Yes	Yes ⁽³⁾	0x00 8020
7	EXTID/H	External interrupt port D/H	Yes	Yes	Yes	Yes ⁽³⁾	0x00 8024
8	EXTI0	External interrupt 0	Yes	Yes	Yes	Yes ⁽³⁾	0x00 8028
9	EXTI1	External interrupt 1	Yes	Yes	Yes	Yes ⁽³⁾	0x00 802C
10	EXTI2	External interrupt 2	Yes	Yes	Yes	Yes ⁽³⁾	0x00 8030
11	EXTI3	External interrupt 3	Yes	Yes	Yes	Yes ⁽³⁾	0x00 8034
12	EXTI4	External interrupt 4	Yes	Yes	Yes	Yes ⁽³⁾	0x00 8038
13	EXTI5	External interrupt 5	Yes	Yes	Yes	Yes ⁽³⁾	0x00 803C
14	EXTI6	External interrupt 6	Yes	Yes	Yes	Yes ⁽³⁾	0x00 8040
15	EXTI7	External interrupt 7	Yes	Yes	Yes	Yes ⁽³⁾	0x00 8044
16	LCD/AES	LCD interrupt/AES interrupt	-	-	Yes	Yes	0x00 8048
17	CLK/TIM1/DAC	System clock switch/CSS interrupt/TIM1 break/DAC	-	-	Yes	Yes	0x00 804C
18	COMP1/COMP2/ADC1	Comparator 1 and 2 interrupt/ADC1	Yes	Yes	Yes	Yes ⁽³⁾	0x00 8050
19	TIM2/USART2	TIM2 update /overflow/trigger/break/ USART2 transmission complete/transmit data register empty interrupt	-	-	Yes	Yes ⁽³⁾	0x00 8054

Table 10. Interrupt mapping (continued)

IRQ No.	Source block	Description	Wakeup from Halt mode	Wakeup from Active-halt mode	Wakeup from Wait (WFI mode)	Wakeup from Wait (WFE mode) ⁽¹⁾	Vector address
20	TIM2/ USART2	Capture/Compare/USART 2 interrupt	-	-	Yes	Yes ⁽³⁾	0x00 8058
21	TIM3/ USART3	TIM3 Update /Overflow/Trigger/Break/ USART3 transmission complete/transmit data register empty interrupt	-	-	Yes	Yes ⁽³⁾	0x00 805C
22	TIM3/ USART3	TIM3 Capture/Compare/ USART3 Receive register data full/overrun/idle line detected/parity error/ interrupt	-	-	Yes	Yes ⁽³⁾	0x00 8060
23	TIM1	Update /overflow/trigger/ COM	-	-	-	Yes ⁽³⁾	0x00 8064
24	TIM1	Capture/Compare	-	-	-	Yes ⁽³⁾	0x00 8068
25	TIM4	Update/overflow/trigger	-	-	Yes	Yes ⁽³⁾	0x00 806C
26	SPI1	End of Transfer	Yes	Yes	Yes	Yes ⁽³⁾	0x00 8070
27	USART 1/ TIM5	USART1 transmission complete/transmit data register empty/ TIM5 update/overflow/ trigger/break	-	-	Yes	Yes ⁽³⁾	0x00 8074
28	USART 1/ TIM5	USART1 Receive register data full/overrun/idle line detected/parity error/ TIM5 capture/compare	-	-	Yes	Yes ⁽³⁾	0x00 8078
29	I ² C1/SPI2	I ² C1 interrupt ⁽⁵⁾ / SPI2	Yes	Yes	Yes	Yes ⁽³⁾	0x00 807C

1. The Low power wait mode is entered when executing a WFE instruction in Low power run mode.
2. The TLI interrupt is the logic OR between TIM2 overflow interrupt, and TIM4 overflow interrupts.
3. In WFE mode, this interrupt is served if it has been previously enabled. After processing the interrupt, the processor goes back to WFE mode. When this interrupt is configured as a wakeup event, the CPU wakes up and resumes processing.
4. The interrupt from PVD is logically OR-ed with Port E and F interrupts. Register EXTI_CONF allows to select between Port E and Port F interrupt (see [External interrupt port select register \(EXTI_CONF\)](#) in the RM0031).
5. The device is woken up from Halt or Active-halt mode only when the address received matches the interface address.

7 Option bytes

Option bytes contain configurations for device hardware features as well as the memory protection of the device. They are stored in a dedicated memory block.

All option bytes can be modified in ICP mode (with SWIM) by accessing the EEPROM address. See [Table 11](#) for details on option byte addresses.

The option bytes can also be modified ‘on the fly’ by the application in IAP mode, except for the ROP, UBC and PCODESIZE values which can only be taken into account when they are modified in ICP mode (with the SWIM).

Refer to the STM8L15x/STM8L16x Flash programming manual (PM0054) and STM8 SWIM and debug manual (UM0470) for information on SWIM programming procedures.

Table 11. Option byte addresses

Address	Option name	Option byte No.	Option bits								Factory default setting
			7	6	5	4	3	2	1	0	
00 4800	Read-out protection (ROP)	OPT0	ROP[7:0]								0x00
00 4802	UBC (User Boot code size)	OPT1	UBC[7:0]								0x00
00 4807	PCODESIZE	OPT2	PCODE[7:0]								0x00
00 4808	Independent watchdog option	OPT3 [3:0]	Reserved				WWDG _HALT	WWDG _HW	IWDG _HALT	IWDG _HW	0x00
00 4809	Number of stabilization clock cycles for HSE and LSE oscillators	OPT4	Reserved				LSECNT[1:0]		HSECNT[1:0]		0x00
00 480A	Brownout reset (BOR)	OPT5 [3:0]	Reserved				BOR_TH			BOR_ON	0x01
00 480B	Bootloader option bytes (OPTBL)	OPTBL [15:0]	OPTBL[15:0]								0x00
00 480C											0x00

Table 12. Option byte description

Option byte no.	Option description
OPT0	ROP[7:0] Memory readout protection (ROP) 0xAA: Disable readout protection (write access via SWIM protocol) Refer to Readout protection section in the STM8L reference manual (RM0031).
OPT1	UBC[7:0] Size of the user boot code area UBC[7:0] Size of the user boot code area 0x00: No UBC 0x01: Page 0 reserved for the UBC and write protected. ... 0xFF: Page 0 to 254 reserved for the UBC and write-protected. Refer to User boot code section in the STM8L reference manual (RM0031).
OPT2	PCODESIZE[7:0] Size of the proprietary code area 0x00: No proprietary code area 0x01: Page 0 reserved for the proprietary code and read/write protected. ... 0xFF: Page 0 to 254 reserved for the proprietary code and read/write protected. Refer to Proprietary code area (PCODE) section in the STM8L reference manual (RM0031) for more details.
OPT3	IWDG_HW: Independent watchdog 0: Independent watchdog activated by software 1: Independent watchdog activated by hardware
	IWDG_HALT: Independent watchdog off in Halt/Active-halt 0: Independent watchdog continues running in Halt/Active-halt mode 1: Independent watchdog stopped in Halt/Active-halt mode
	WWDG_HW: Window watchdog 0: Window watchdog activated by software 1: Window watchdog activated by hardware
	WWDG_HALT: Window window watchdog reset on Halt/Active-halt 0: Window watchdog stopped in Halt mode 1: Window watchdog generates a reset when MCU enters Halt mode
OPT4	HSECNT: Number of HSE oscillator stabilization clock cycles 0x00 - 1 clock cycle 0x01 - 16 clock cycles 0x10 - 512 clock cycles 0x11 - 4096 clock cycles
	LSECNT: Number of LSE oscillator stabilization clock cycles 0x00 - 1 clock cycle 0x01 - 16 clock cycles 0x10 - 512 clock cycles 0x11 - 4096 clock cycles

Table 12. Option byte description (continued)

Option byte no.	Option description
OPT5	BOR_ON: 0: Brownout reset off 1: Brownout reset on
	BOR_TH[3:1]: Brownout reset thresholds. Refer to Table 19 for details on the thresholds according to the value of BOR_TH bits.
OPTBL	OPTBL[15:0]: This option is checked by the boot ROM code after reset. Depending on the content of addresses 00 480B, 00 480C and 0x8000 (reset vector) the CPU jumps to the bootloader or to the reset vector. Refer to the UM0560 bootloader user manual for more details.

8 Unique ID

Devices feature a 96-bit unique device identifier which provides a reference number that is unique for any device and in any context. The 96 bits of the identifier can never be altered by the user.

The unique device identifier can be read in single bytes and may then be concatenated using a custom algorithm.

The unique device identifier is ideally suited:

- For use as serial numbers
- For use as security keys to increase the code security in the program memory while using and combining this unique ID with software cryptographic primitives and protocols before programming the internal memory.
- To activate secure boot processes

Table 13. Unique ID registers (96 bits)

Address	Content description	Unique ID bits						
		7	6	5	4	3	2	1
0x4926	X co-ordinate on the wafer	U_ID[7:0]						
0x4927		U_ID[15:8]						
0x4928	Y co-ordinate on the wafer	U_ID[23:16]						
0x4929		U_ID[31:24]						
0x492A	Wafer number	U_ID[39:32]						
0x492B	Lot number	U_ID[47:40]						
0x492C		U_ID[55:48]						
0x492D		U_ID[63:56]						
0x492E		U_ID[71:64]						
0x492F		U_ID[79:72]						
0x4930		U_ID[87:80]						
0x4931		U_ID[95:88]						

9 Electrical parameters

9.1 Parameter conditions

Unless otherwise specified, all voltages are referred to V_{SS} .

9.1.1 Minimum and maximum values

Unless otherwise specified the minimum and maximum values are guaranteed in the worst conditions of ambient temperature, supply voltage and frequencies by tests in production on 100% of the devices with an ambient temperature at $T_A = 25\text{ °C}$ and $T_A = T_A \text{ max}$ (given by the selected temperature range).

Data based on characterization results, design simulation and/or technology characteristics are indicated in the table footnotes and are not tested in production. Based on characterization, the minimum and maximum values refer to sample tests and represent the mean value plus or minus three times the standard deviation ($\text{mean} \pm 3\Sigma$).

9.1.2 Typical values

Unless otherwise specified, typical data are based on $T_A = 25\text{ °C}$, $V_{DD} = 3\text{ V}$. They are given only as design guidelines and are not tested.

Typical ADC accuracy values are determined by characterization of a batch of samples from a standard diffusion lot over the full temperature range, where 95% of the devices have an error less than or equal to the value indicated ($\text{mean} \pm 2\Sigma$).

9.1.3 Typical curves

Unless otherwise specified, all typical curves are given only as design guidelines and are not tested.

9.1.4 Loading capacitor

The loading conditions used for pin parameter measurement are shown in [Figure 6](#).

Figure 6. Pin loading conditions

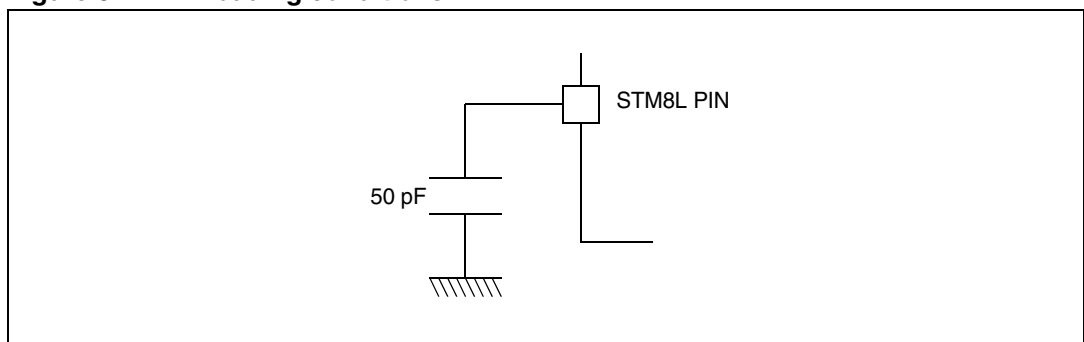

9.1.5 Pin input voltage

The input voltage measurement on a pin of the device is described in [Figure 7](#).

Figure 7. Pin input voltage

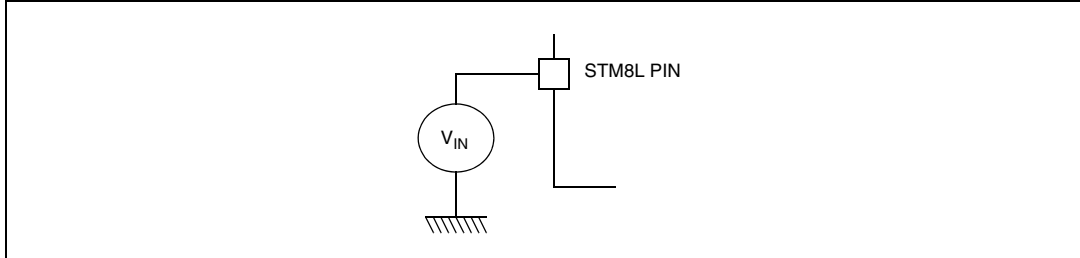

9.2 Absolute maximum ratings

Stresses above those listed as “absolute maximum ratings” may cause permanent damage to the device. This is a stress rating only and functional operation of the device under these conditions is not implied. Exposure to maximum rating conditions for extended periods may affect device reliability.

Table 14. Voltage characteristics

Symbol	Ratings	Min	Max	Unit
$V_{DD} - V_{SS}$	External supply voltage (including V_{DDA}) ⁽¹⁾	- 0.3	4.0	V
V_{IN} ⁽²⁾	Input voltage on true open-drain pins (PC0 and PC1)	$V_{SS} - 0.3$	$V_{DD} + 4.0$	
	Input voltage on five-volt tolerant (FT) pins	$V_{SS} - 0.3$	$V_{DD} + 4.0$	
	Input voltage on any other pin	$V_{SS} - 0.3$	4.0	
V_{ESD}	Electrostatic discharge voltage	see Absolute maximum ratings (electrical sensitivity) on page 115		

1. All power (V_{DD1} , V_{DD2} , V_{DD3} , V_{DD4} , V_{DDA}) and ground (V_{SS1} , V_{SS2} , V_{SS3} , V_{SS4} , V_{SSA}) pins must always be connected to the external power supply.
2. V_{IN} maximum must always be respected. Refer to [Table 15](#) for maximum allowed injected current values.

Table 15. Current characteristics

Symbol	Ratings	Max.	Unit
I_{VDD}	Total current into V_{DD} power line (source)	80	mA
I_{VSS}	Total current out of V_{SS} ground line (sink)	80	
I_{IO}	Output current sunk by IR_TIM pin (with high sink LED driver capability)	80	
	Output current sunk by any other I/O and control pin	25	
	Output current sourced by any I/Os and control pin	- 25	
$I_{INJ(PIN)}$	Injected current on true open-drain pins (PC0 and PC1) ⁽¹⁾	- 5 / +0	
	Injected current on five-volt tolerant (FT) pins ⁽¹⁾	- 5 / +0	
	Injected current on any other pin ⁽²⁾	- 5 / +5	
$\Sigma I_{INJ(PIN)}$	Total injected current (sum of all I/O and control pins) ⁽³⁾	± 25	

1. Positive injection is not possible on these I/Os. A negative injection is induced by $V_{IN} < V_{SS}$. $I_{INJ(PIN)}$ must never be exceeded. Refer to [Table 14](#). for maximum allowed input voltage values.
2. A positive injection is induced by $V_{IN} > V_{DD}$ while a negative injection is induced by $V_{IN} < V_{SS}$. $I_{INJ(PIN)}$ must never be exceeded. Refer to [Table 14](#). for maximum allowed input voltage values.
3. When several inputs are submitted to a current injection, the maximum $\Sigma I_{INJ(PIN)}$ is the absolute sum of the positive and negative injected currents (instantaneous values).

Table 16. Thermal characteristics

Symbol	Ratings	Value	Unit
T_{STG}	Storage temperature range	-65 to +150	°C
T_J	Maximum junction temperature	150	

9.3 Operating conditions

Subject to general operating conditions for V_{DD} and T_A .

9.3.1 General operating conditions

Table 17. General operating conditions

Symbol	Parameter	Conditions	Min.	Max.	Unit	
$f_{\text{SYSCLK}}^{(1)}$	System clock frequency	$1.65 \text{ V} \leq V_{DD} < 3.6 \text{ V}$	0	16	MHz	
V_{DD}	Standard operating voltage	BOR detector disabled (D suffix version)	1.65	3.6	V	
		BOR detector enabled	1.8 ⁽²⁾			
V_{DDA}	Analog operating voltage	ADC and DAC not used	Must be at the same potential as V_{DD}	1.65	3.6	V
		ADC or DAC used				
$P_D^{(3)}$	Power dissipation at $T_A = 85 \text{ °C}$ for suffix 6 devices	LQFP80		288	mW	
		LQFP64		288		
		UFQFPN48		288		
		LQFP48		288		
	Power dissipation at $T_A = 125 \text{ °C}$ for suffix 3 devices and at $T_A = 105 \text{ °C}$ for suffix 7 devices	LQFP80		131		
		LQFP64		104		
		UFQFPN48		156		
		LQFP48		77		
T_A	Temperature range	$1.65 \text{ V} \leq V_{DD} < 3.6 \text{ V}$ (6 suffix version)	-40	85	°C	
		$1.65 \text{ V} \leq V_{DD} < 3.6 \text{ V}$ (7 suffix version)	-40	105		
		$1.65 \text{ V} \leq V_{DD} < 3.6 \text{ V}$ (3 suffix version)	-40	125		
T_J	Junction temperature range	$-40 \text{ °C} \leq T_A < 85 \text{ °C}$ (6 suffix version)	-40	105	°C	
		$-40 \text{ °C} \leq T_A < 105 \text{ °C}$ (7 suffix version)	-40	110 ⁽⁴⁾		
		$-40 \text{ °C} \leq T_A < 125 \text{ °C}$ (3 suffix version)	-40	130 ⁽⁴⁾		

1. $f_{\text{SYSCLK}} = f_{\text{CPU}}$

2. 1.8 V at power-up, 1.65 V at power-down if BOR is disabled by option byte

3. To calculate $P_{D\text{max}}(T_A)$, use the formula $P_{D\text{max}} = (T_{J\text{max}} - T_A) / \Theta_{JA}$ with $T_{J\text{max}}$ in this table and Θ_{JA} in "Thermal characteristics" table.

4. $T_{J\text{max}}$ is given by the test limit. Above this value the product behavior is not guaranteed.

9.3.2 Embedded reset and power control block characteristics

Table 18. Embedded reset and power control block characteristics

Symbol	Parameter	Conditions	Min.	Typ.	Max.	Unit
t _{VDD}	V _{DD} rise time rate	BOR detector enabled	0 ⁽¹⁾		∞ ⁽¹⁾	μs/V
		BOR detector disabled	0 ⁽¹⁾		1 ⁽¹⁾	ms/V
	V _{DD} fall time rate	BOR detector enabled	20 ⁽¹⁾		∞ ⁽¹⁾	μs/V
		BOR detector disabled	Reset below voltage functional range			
t _{TEMP}	Reset release delay	V _{DD} rising BOR detector enabled		3		ms
		V _{DD} rising BOR detector disabled		1		
V _{POR}	Power-on reset threshold	Rising edge	1.3 ⁽²⁾	1.5	1.65	V
V _{PDR}	Power-down reset threshold	Falling edge	1.3 ⁽²⁾	1.5	1.65	
V _{BOR0}	Brown-out reset threshold 0 (BOR_TH[2:0]=000)	Falling edge	1.67	1.7	1.74	
		Rising edge	1.69	1.75	1.80	
V _{BOR1}	Brown-out reset threshold 1 (BOR_TH[2:0]=001)	Falling edge	1.87	1.93	1.97	
		Rising edge	1.96	2.04	2.07	
V _{BOR2}	Brown-out reset threshold 2 (BOR_TH[2:0]=010)	Falling edge	2.22	2.3	2.35	
		Rising edge	2.31	2.41	2.44	
V _{BOR3}	Brown-out reset threshold 3 (BOR_TH[2:0]=011)	Falling edge	2.45	2.55	2.60	
		Rising edge	2.54	2.66	2.7	
V _{BOR4}	Brown-out reset threshold 4 (BOR_TH[2:0]=100)	Falling edge	2.68	2.80	2.85	
		Rising edge	2.78	2.90	2.95	

Table 18. Embedded reset and power control block characteristics (continued)

Symbol	Parameter	Conditions	Min.	Typ.	Max.	Unit
V _{PVD0}	PVD threshold 0	Falling edge	1.80	1.84	1.88	V
		Rising edge	1.88	1.94	1.99	
V _{PVD1}	PVD threshold 1	Falling edge	1.98	2.04	2.09	
		Rising edge	2.08	2.14	2.18	
V _{PVD2}	PVD threshold 2	Falling edge	2.2	2.24	2.28	
		Rising edge	2.28	2.34	2.38	
V _{PVD3}	PVD threshold 3	Falling edge	2.39	2.44	2.48	
		Rising edge	2.47	2.54	2.58	
V _{PVD4}	PVD threshold 4	Falling edge	2.57	2.64	2.69	
		Rising edge	2.68	2.74	2.79	
V _{PVD5}	PVD threshold 5	Falling edge	2.77	2.83	2.88	
		Rising edge	2.87	2.94	2.99	
V _{PVD6}	PVD threshold 6	Falling edge	2.97	3.05	3.09	
		Rising edge	3.08	3.15	3.20	
V _{hyst}	Hysteresis voltage	BOR0 threshold		40		mV
		All BOR and PVD thresholds excepting BOR0		100		

1. Data guaranteed by design, not tested in production.
2. Data based on characterization results, not tested in production.

Figure 8. Power supply thresholds

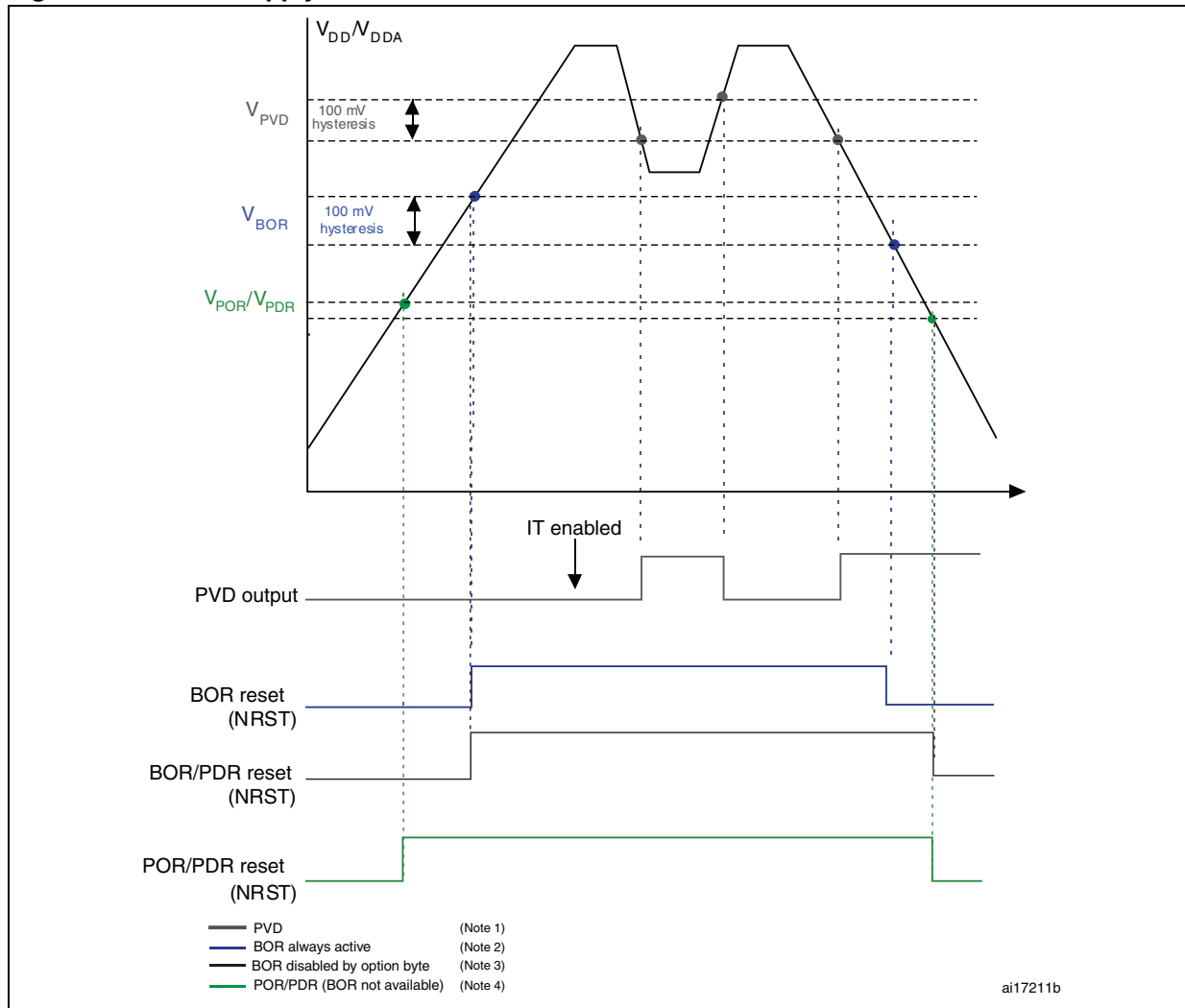

9.3.3 Supply current characteristics

Total current consumption

The MCU is placed under the following conditions:

- All I/O pins in input mode with a static value at V_{DD} or V_{SS} (no load)
- All peripherals are disabled except if explicitly mentioned.

In the following table, data are based on characterization results, unless otherwise specified.

Subject to general operating conditions for V_{DD} and T_A .

Table 19. Total current consumption in Run mode

Symbol	Parameter	Conditions ⁽¹⁾			Typ.	Max.				Unit
						55 °C	85 °C (2)	105 °C (3)	125 °C (4)	
$I_{DD(RUN)}$	Supply current in run mode ⁽⁵⁾	All peripherals OFF, code executed from RAM, V_{DD} from 1.65 V to 3.6 V	HSI RC osc. (16 MHz) ⁽⁶⁾	$f_{CPU} = 125 \text{ kHz}$	0.22	0.28	0.39	0.47	0.51	mA
				$f_{CPU} = 1 \text{ MHz}$	0.32	0.38	0.49	0.57	0.61	
				$f_{CPU} = 4 \text{ MHz}$	0.59	0.65	0.76	0.84	0.88	
				$f_{CPU} = 8 \text{ MHz}$	0.93	0.99	1.1	1.18	1.22	
				$f_{CPU} = 16 \text{ MHz}$	1.62	1.68	1.79 ⁽⁷⁾	1.87 ⁽⁷⁾	1.91 ⁽⁷⁾	
			HSE external clock ($f_{CPU}=f_{HSE}$) ⁽⁸⁾	$f_{CPU} = 125 \text{ kHz}$	0.21	0.25	0.35	0.44	0.49	
				$f_{CPU} = 1 \text{ MHz}$	0.3	0.34	0.44	0.53	0.58	
				$f_{CPU} = 4 \text{ MHz}$	0.57	0.61	0.71	0.8	0.85	
				$f_{CPU} = 8 \text{ MHz}$	0.95	0.99	1.09	1.18	1.23	
			LSI RC osc. (typ. 38 kHz)	$f_{CPU} = f_{LSI}$	0.029	0.035	0.039	0.044	0.055	
					0.028	0.034	0.038	0.042	0.054	
			LSE external clock (32.768 kHz)	$f_{CPU} = f_{LSE}$	0.028	0.034	0.038	0.042	0.054	

Table 19. Total current consumption in Run mode (continued)

Symbol	Parameter	Conditions ⁽¹⁾		Typ.	Max.				Unit	
					55 °C	85 °C (2)	105 °C (3)	125 °C (4)		
I _{DD(RUN)}	Supply current in Run mode	All peripherals OFF, code executed from Flash, V _{DD} from 1.65 V to 3.6 V	HSI RC osc. ⁽⁹⁾	f _{CPU} = 125 kHz	0.35	0.46	0.48	0.51	0.59	mA
				f _{CPU} = 1 MHz	0.54	0.65	0.67	0.7	0.78	
				f _{CPU} = 4 MHz	1.16	1.27	1.29	1.32	1.4	
				f _{CPU} = 8 MHz	1.97	2.08	2.1	2.13	2.21	
				f _{CPU} = 16 MHz	3.54	3.65	3.67	3.7	3.78	
			HSE external clock (f _{CPU} =f _{HSE}) ⁽⁸⁾	f _{CPU} = 125 kHz	0.35	0.44	0.46	0.49	0.58	
				f _{CPU} = 1 MHz	0.53	0.62	0.64	0.67	0.76	
				f _{CPU} = 4 MHz	1.13	1.22	1.24	1.27	1.36	
				f _{CPU} = 8 MHz	2	2.09	2.11	2.14	2.23	
				f _{CPU} = 16 MHz	3.69	3.78	3.8	3.83	3.92	
			LSI RC osc.	f _{CPU} = f _{LSI}	0.110	0.123	0.130	0.138	0.180	
			LSE external clock (32.768 kHz) ⁽¹⁰⁾	f _{CPU} = f _{LSE}	0.100	0.101	0.104	0.119	0.163	

- All peripherals OFF, V_{DD} from 1.65 V to 3.6 V, HSI internal RC osc., f_{CPU}=f_{SYSCLK}
- For devices with suffix 6
- For devices with suffix 7
- For devices with suffix 3
- CPU executing typical data processing
- The run from RAM consumption can be approximated with the linear formula:
I_{DD(run_from_RAM)} = Freq. * 95 μA/MHz + 250 μA
- Tested in production.
- Oscillator bypassed (HSEBYP = 1 in CLK_ECKCR). When configured for external crystal, the HSE consumption (I_{DD HSE}) must be added. Refer to [Table 30](#).
- The run from Flash consumption can be approximated with the linear formula:
I_{DD(run_from_Flash)} = Freq. * 200 μA/MHz + 330 μA
- Oscillator bypassed (LSEBYP = 1 in CLK_ECKCR). When configured for external crystal, the LSE consumption (I_{DD LSE}) must be added. Refer to [Table 31](#)

Figure 9. Typical $I_{DD(RUN)}$ from RAM vs. V_{DD} (HSI clock source), $f_{CPU} = 16$ MHz

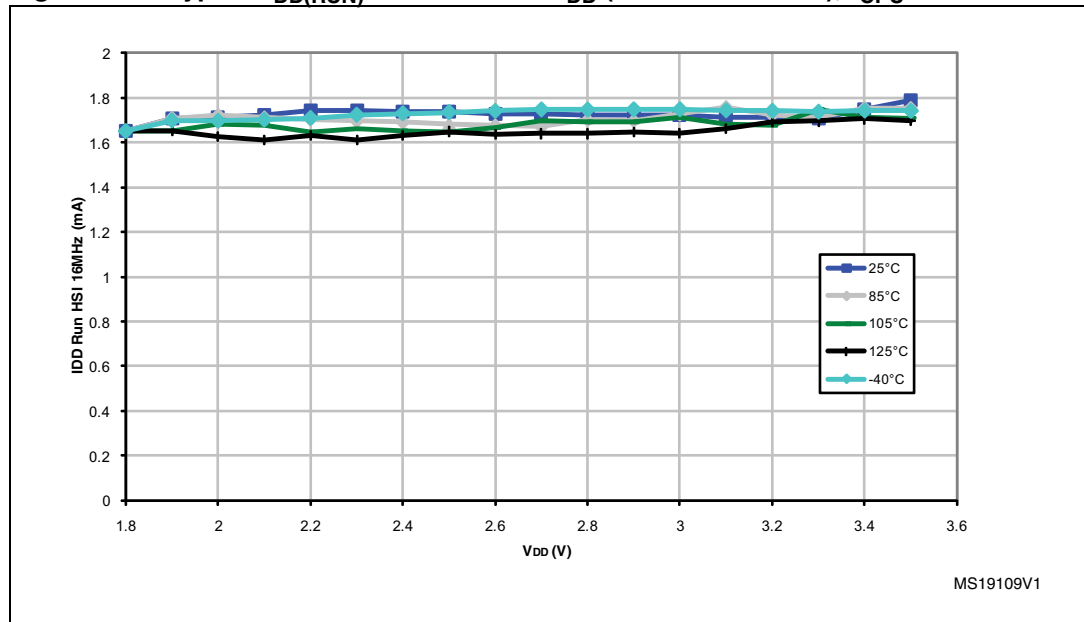

1. Typical current consumption measured with code executed from RAM.

Figure 10. Typical $I_{DD(RUN)}$ from Flash vs. V_{DD} (HSI clock source), $f_{CPU} = 16$ MHz

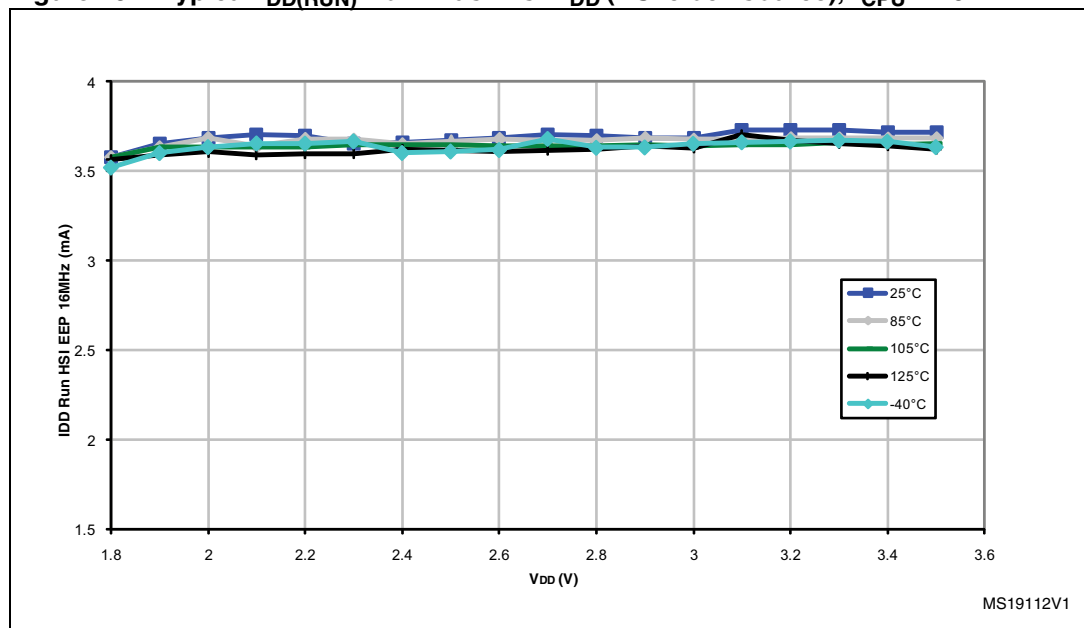

1. Typical current consumption measured with code executed from Flash.

In the following table, data are based on characterization results, unless otherwise specified.

Table 20. Total current consumption in Wait mode

Symbol	Parameter	Conditions ⁽¹⁾		Typ	Max				Unit	
					55 °C	85 °C (2)	105 °C (3)	125 °C (4)		
I _{DD(Wait)}	Supply current in Wait mode	CPU not clocked, all peripherals OFF, code executed from RAM with Flash in I _{DDQ} mode, ⁽⁵⁾ V _{DD} from 1.65 V to 3.6 V	HSI	f _{CPU} = 125 kHz	0.21	0.29	0.33	0.36	0.43	mA
				f _{CPU} = 1 MHz	0.25	0.33	0.37	0.4	0.47	
				f _{CPU} = 4 MHz	0.32	0.4	0.44	0.47	0.54	
				f _{CPU} = 8 MHz	0.42	0.496	0.54	0.56	0.64	
				f _{CPU} = 16 MHz	0.66	0.736	0.78 ⁽⁶⁾	0.8 ⁽⁶⁾	0.88 ⁽⁶⁾	
			HSE external clock (f _{CPU} =f _{HSE}) ⁽⁷⁾	f _{CPU} = 125 kHz	0.19	0.21	0.3	0.35	0.41	
				f _{CPU} = 1 MHz	0.2	0.23	0.32	0.36	0.43	
				f _{CPU} = 4 MHz	0.27	0.3	0.39	0.43	0.5	
				f _{CPU} = 8 MHz	0.37	0.4	0.49	0.53	0.6	
			LSI	f _{CPU} = f _{LSI}	0.028	0.037	0.039	0.044	0.054	
				LSE ⁽⁸⁾ external clock (32.768 kHz)	f _{CPU} = f _{LSE}	0.027	0.035	0.038	0.042	

Table 20. Total current consumption in Wait mode (continued)

Symbol	Parameter	Conditions ⁽¹⁾			Typ	Max				Unit
						55 °C	85 °C (2)	105 °C (3)	125 °C (4)	
I _{DD(Wait)}	Supply current in Wait mode	CPU not clocked, all peripherals OFF, code executed from Flash, V _{DD} from 1.65 V to 3.6 V	HSI	f _{CPU} = 125 kHz	0.27	0.36	0.42	0.46	0.51	mA
				f _{CPU} = 1 MHz	0.29	0.38	0.44	0.48	0.53	
				f _{CPU} = 4 MHz	0.37	0.46	0.52	0.56	0.61	
				f _{CPU} = 8 MHz	0.45	0.55	0.61	0.65	0.7	
				f _{CPU} = 16 MHz	0.69	0.79	0.85	0.89	0.94	
			HSE ⁽⁷⁾ external clock (f _{CPU} =HSE)	f _{CPU} = 125 kHz	0.23	0.29	0.32	0.4	0.47	
				f _{CPU} = 1 MHz	0.24	0.31	0.34	0.41	0.48	
				f _{CPU} = 4 MHz	0.32	0.39	0.42	0.49	0.56	
				f _{CPU} = 8 MHz	0.42	0.49	0.51	0.59	0.66	
			LSI	f _{CPU} = f _{LSI}	0.037	0.085	0.105	0.123	0.153	
				LSE ⁽⁸⁾ external clock (32.768 kHz)	f _{CPU} = f _{LSE}	0.036	0.082	0.095	0.119	

1. All peripherals OFF, V_{DD} from 1.65 V to 3.6 V, HSI internal RC osc., f_{CPU} = f_{SYSCLK}
2. For devices with suffix 6.
3. For devices with suffix 7.
4. For devices with suffix 3.
5. Flash is configured in I_{DDQ} mode in Wait mode by setting the EPM or WAITM bit in the Flash_CR1 register.
6. Tested in production.
7. Oscillator bypassed (HSEBYP = 1 in CLK_ECKCR). When configured for external crystal, the HSE consumption (I_{DD HSE}) must be added. Refer to [Table 30](#).
8. Oscillator bypassed (LSEBYP = 1 in CLK_ECKCR). When configured for external crystal, the LSE consumption (I_{DD HSE}) must be added. Refer to [Table 31](#)

Figure 11. Typical $I_{DD(Wait)}$ from RAM vs. V_{DD} (HSI clock source), $f_{CPU} = 16$ MHz

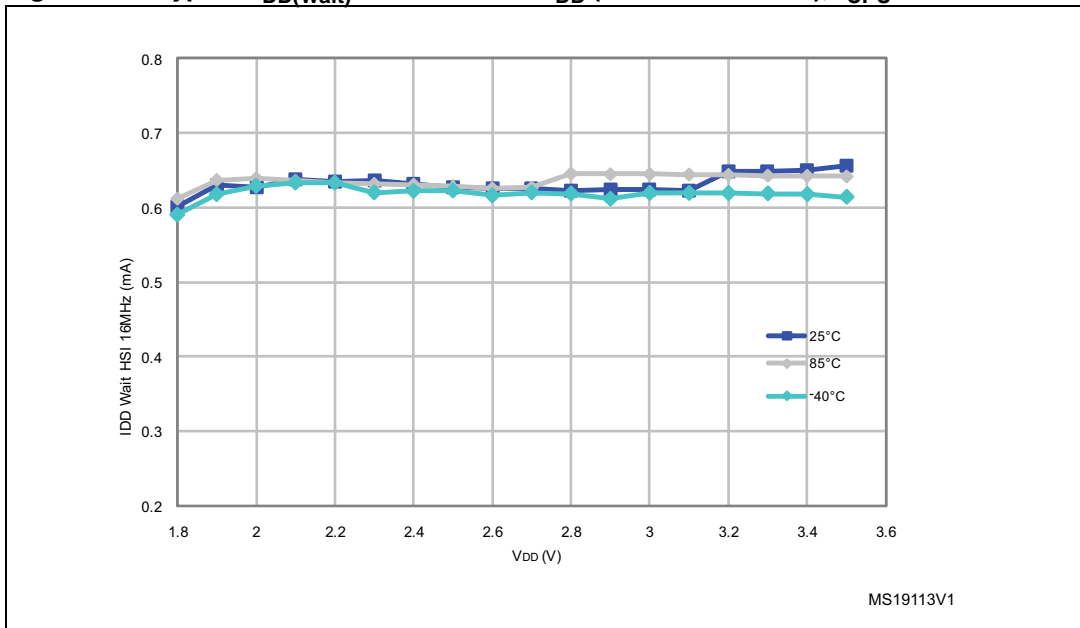

1. Typical current consumption measured with code executed from RAM.

Figure 12. Typical $I_{DD(Wait)}$ from Flash (HSI clock source), $f_{CPU} = 16$ MHz

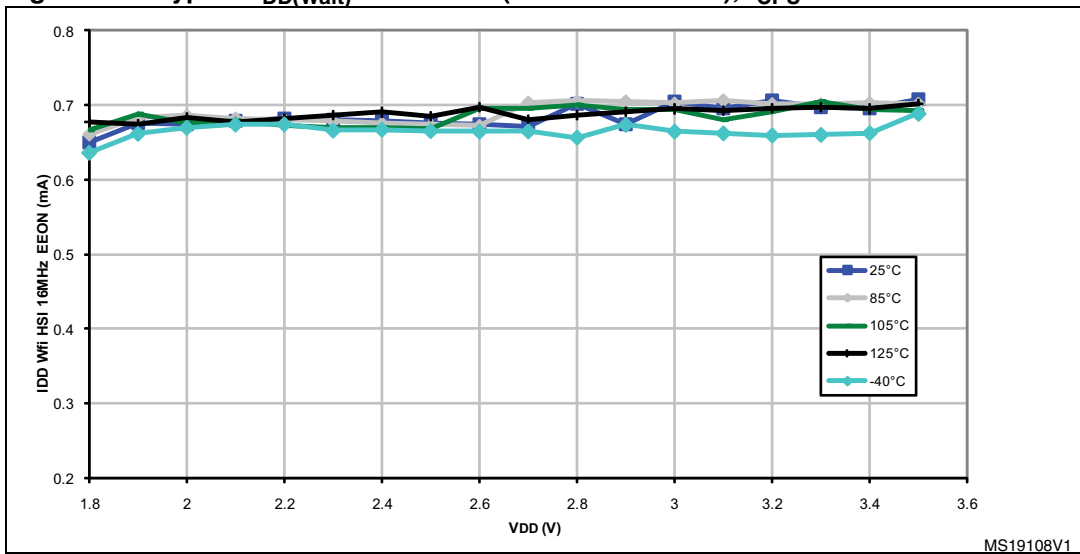

1. Typical current consumption measured with code executed from Flash.

In the following table, data are based on characterization results, unless otherwise specified.

Table 21. Total current consumption and timing in Low power run mode at V_{DD} = 1.65 V to 3.6 V

Symbol	Parameter	Conditions ⁽¹⁾		Typ.	Max.	Unit	
I _{DD(LPR)}	Supply current in Low power run mode	LSI RC osc. (at 38 kHz)	all peripherals OFF	T _A = -40 °C to 25 °C	5.86	6.38	μA
				T _A = 55 °C	6.52	7.06	
				T _A = 85 °C	7.68	8.7	
				T _A = 105 °C	10.14	11.77	
				T _A = 125 °C	14.4	18.27	
			with TIM2 active ⁽²⁾	T _A = -40 °C to 25 °C	6.2	6.73	
				T _A = 55 °C	6.86	7.41	
				T _A = 85 °C	9.71	10.81	
				T _A = 105 °C	13.17	15.39	
				T _A = 125 °C	16.72	21.1	
		LSE ⁽³⁾ external clock (32.768 kHz)	all peripherals OFF	T _A = -40 °C to 25 °C	5.42	5.94	
				T _A = 55 °C	5.9	6.52	
				T _A = 85 °C	6.14	6.8	
				T _A = 105 °C	7.46	8.2	
			with TIM2 active ⁽²⁾	T _A = 125 °C	10.25	12.81	
				T _A = -40 °C to 25 °C	5.87	6.48	
T _A = 55 °C	6.44			6.95			
T _A = 85 °C	6.7			7.65			
T _A = 105 °C	8.01	9.15					
T _A = 125 °C	10.62	16.09					

1. No floating I/Os
2. Timer 2 clock enabled and counter running
3. Oscillator bypassed (LSEBYP = 1 in CLK_ECKCR). When configured for external crystal, the LSE consumption (I_{DD LSE}) must be added. Refer to [Table 31](#)

Figure 13. Typical $I_{DD(LPR)}$ vs. V_{DD} (LSI clock source), all peripherals OFF

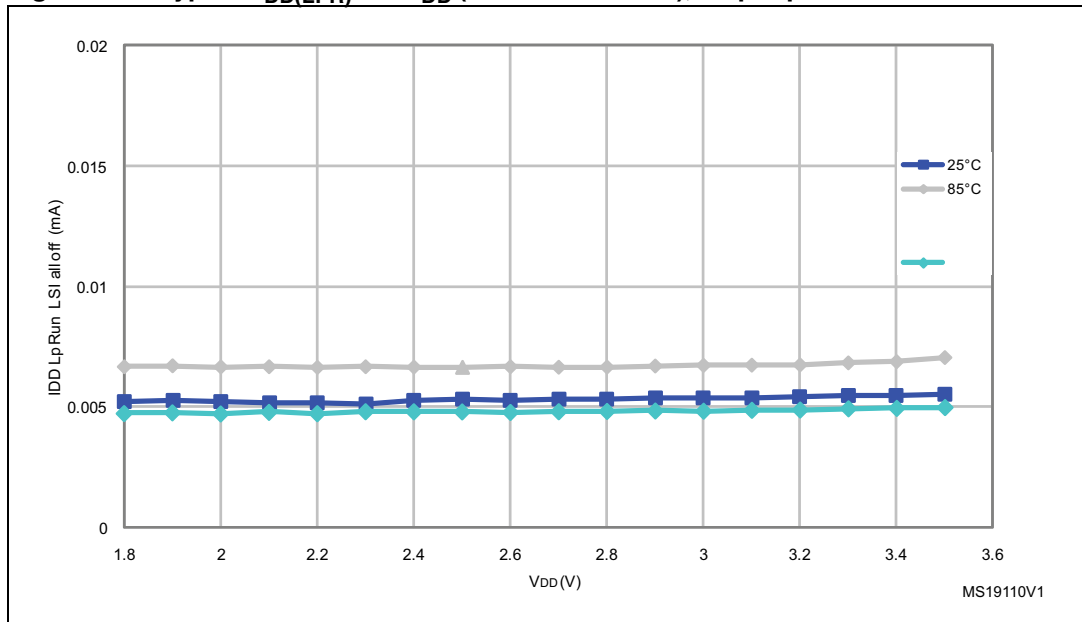

In the following table, data are based on characterization results, unless otherwise specified.

Table 22. Total current consumption in Low power wait mode at V_{DD} = 1.65 V to 3.6 V

Symbol	Parameter	Conditions ⁽¹⁾		Typ.	Max.	Unit	
I _{DD(LPW)}	Supply current in Low power wait mode	LSI RC osc. (at 38 kHz)	all peripherals OFF	T _A = -40 °C to 25 °C	3.03	3.41	μA
				T _A = 55 °C	3.38	3.78	
				T _A = 85 °C	4.6	5.34	
				T _A = 105 °C	7.25	8.84	
				T _A = 125 °C	11.89	16.18	
			with TIM2 active ⁽²⁾	T _A = -40 °C to 25 °C	3.78	4.21	
				T _A = 55 °C	4.13	4.57	
				T _A = 85 °C	5.29	6.08	
				T _A = 105 °C	7.54	9.13	
				T _A = 125 °C	12.47	15.56	
		LSE external clock ⁽³⁾ (32.768 kHz)	all peripherals OFF	T _A = -40 °C to 25 °C	2.46	2.89	
				T _A = 55 °C	2.58	3.07	
				T _A = 85 °C	3.32	4.05	
				T _A = 105 °C	4.63	6.17	
				T _A = 125 °C	7.52	11.68	
			with TIM2 active ⁽²⁾	T _A = -40 °C to 25 °C	2.88	3.29	
				T _A = 55 °C	2.97	3.42	
				T _A = 85 °C	3.69	4.55	
T _A = 105 °C	5.09			6.78			
T _A = 125 °C	7.91			12.15			

1. No floating I/Os.
2. Timer 2 clock enabled and counter is running.
3. Oscillator bypassed (LSEBYP = 1 in CLK_ECKCR). When configured for external crystal, the LSE consumption (I_{DD LSE}) must be added. Refer to [Table 31](#).

Figure 14. Typical $I_{DD(LPW)}$ vs. V_{DD} (LSI clock source), all peripherals OFF

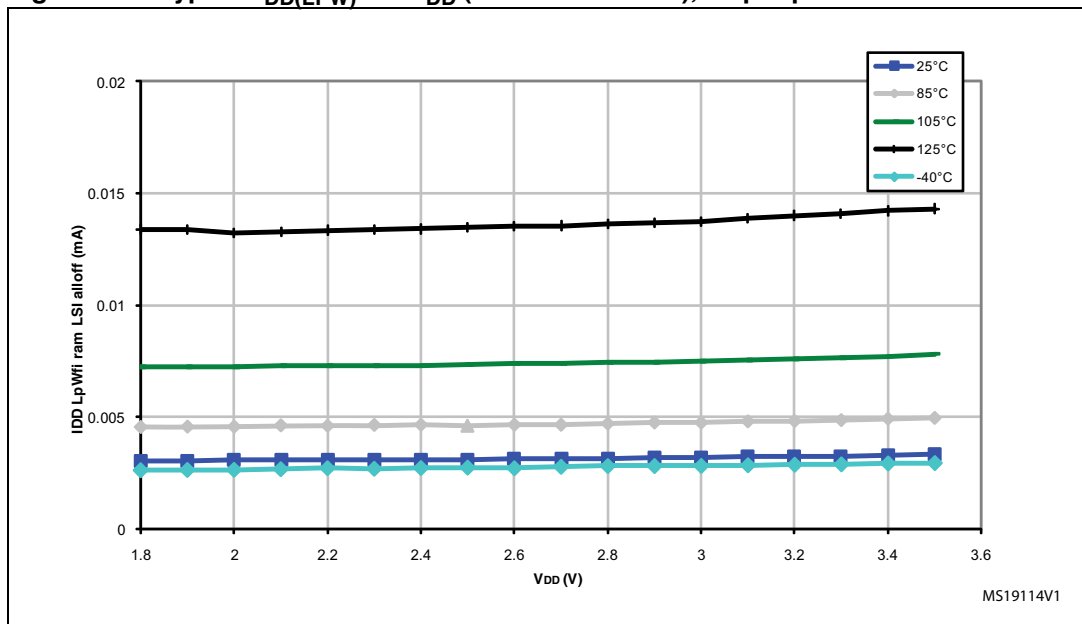

1. Typical current consumption measured with code executed from RAM.

In the following table, data are based on characterization results, unless otherwise specified.

Table 23. Total current consumption and timing in Active-halt mode at $V_{DD} = 1.65\text{ V}$ to 3.6 V

Symbol	Parameter	Conditions ⁽¹⁾		Typ.	Max.	Unit	
$I_{DD(AH)}$	Supply current in Active-halt mode	LSI RC (at 38 kHz)	LCD OFF ⁽²⁾	$T_A = -40\text{ °C}$ to 25 °C	0.92	2.25	μA
				$T_A = 55\text{ °C}$	1.32	3.44	
				$T_A = 85\text{ °C}$	1.63	3.87	
				$T_A = 105\text{ °C}$	3	7.94	
				$T_A = 125\text{ °C}$	5.6	13.8	
			LCD ON (static duty/ external V_{LCD}) ⁽³⁾	$T_A = -40\text{ °C}$ to 25 °C	1.56	3.6	
				$T_A = 55\text{ °C}$	1.64	3.8	
				$T_A = 85\text{ °C}$	2.12	5.03	
				$T_A = 105\text{ °C}$	3.34	8.2	
				$T_A = 125\text{ °C}$	5.83	14.4	
			LCD ON (1/4 duty/ external V_{LCD}) ⁽⁴⁾	$T_A = -40\text{ °C}$ to 25 °C	1.92	4.56	
				$T_A = 55\text{ °C}$	2.1	4.97	
				$T_A = 85\text{ °C}$	2.6	6.14	
				$T_A = 105\text{ °C}$	3.62	8.49	
				$T_A = 125\text{ °C}$	6.1	15.92	
			LCD ON (1/4 duty/ internal V_{LCD}) ⁽⁵⁾	$T_A = -40\text{ °C}$ to 25 °C	4.2	9.88	
				$T_A = 55\text{ °C}$	4.39	10.32	
				$T_A = 85\text{ °C}$	4.84	11.5	
				$T_A = 105\text{ °C}$	5.98	15	
				$T_A = 125\text{ °C}$	7.21	18.07	

Table 23. Total current consumption and timing in Active-halt mode at $V_{DD} = 1.65\text{ V to }3.6\text{ V}$ (continued)

Symbol	Parameter	Conditions ⁽¹⁾			Typ.	Max.	Unit					
$I_{DD(AH)}$	Supply current in Active-halt mode	LSE external clock (32.768 kHz) ⁽⁶⁾	LCD OFF ⁽⁷⁾	$T_A = -40\text{ °C to }25\text{ °C}$	0.54	1.35	μA					
				$T_A = 55\text{ °C}$	0.61	1.44						
				$T_A = 85\text{ °C}$	0.91	2.27						
				$T_A = 105\text{ °C}$	2.24	5.42						
				$T_A = 125\text{ °C}$	5.03	12						
			LCD ON (static duty/external V_{LCD}) ⁽³⁾	$T_A = -40\text{ °C to }25\text{ °C}$	0.91	2.13						
				$T_A = 55\text{ °C}$	1.05	2.55						
				$T_A = 85\text{ °C}$	1.42	3.65						
				$T_A = 105\text{ °C}$	2.63	6.35						
			LCD ON (1/4 duty/external V_{LCD}) ⁽⁴⁾	$T_A = -40\text{ °C to }25\text{ °C}$	1.6	2.84						
				$T_A = 55\text{ °C}$	1.76	4.37						
				$T_A = 85\text{ °C}$	2.14	5.23						
				$T_A = 105\text{ °C}$	3.37	8.5						
			LCD ON (1/4 duty/internal V_{LCD}) ⁽⁵⁾	$T_A = -40\text{ °C to }25\text{ °C}$	3.89	9.15						
				$T_A = 55\text{ °C}$	3.89	9.15						
				$T_A = 85\text{ °C}$	4.25	10.49						
				$T_A = 105\text{ °C}$	5.42	16.31						
								$T_A = 125\text{ °C}$	6.58	16.6		
$I_{DD(WUFAH)}$	Supply current during wakeup time from Active-halt mode (using HSI)				2.4		mA					
$t_{WU_HSI(AH)}^{(8)(9)}$	Wakeup time from Active-halt mode to Run mode (using HSI)				4.7	7	μs					
$t_{WU_LSI(AH)}^{(8)(9)}$	Wakeup time from Active-halt mode to Run mode (using LSI)				150		μs					

1. No floating I/O, unless otherwise specified.
2. RTC enabled. Clock source = LSI
3. RTC enabled, LCD enabled with external $V_{LCD} = 3\text{ V}$, static duty, division ratio = 256, all pixels active, no LCD connected.
4. RTC enabled, LCD enabled with external V_{LCD} , 1/4 duty, 1/3 bias, division ratio = 64, all pixels active, no LCD connected.
5. LCD enabled with internal LCD booster $V_{LCD} = 3\text{ V}$, 1/4 duty, 1/3 bias, division ratio = 64, all pixels active, no LCD connected.
6. Oscillator bypassed (LSEBYP = 1 in CLK_ECKCR). When configured for external crystal, the LSE consumption ($I_{DD\text{ LSE}}$) must be added. Refer to [Table 31](#)

7. RTC enabled. Clock source = LSE
8. Wakeup time until start of interrupt vector fetch.
The first word of interrupt routine is fetched 4 CPU cycles after t_{WU} .
9. ULP=0 or ULP=1 and FWU=1 in the PWR_CSR2 register.

Table 24. Typical current consumption in Active-halt mode, RTC clocked by LSE external crystal

Symbol	Parameter	Condition ⁽¹⁾	Typ.	Unit	
$I_{DD(AH)}$ ⁽²⁾	Supply current in Active-halt mode	$V_{DD} = 1.8\text{ V}$	LSE	1.2	μA
			LSE/32 ⁽³⁾	0.9	
		$V_{DD} = 3\text{ V}$	LSE	1.4	
			LSE/32 ⁽³⁾	1.1	
		$V_{DD} = 3.6\text{ V}$	LSE	1.6	
			LSE/32 ⁽³⁾	1.3	

1. No floating I/O, unless otherwise specified.
2. Based on measurements on bench with 32.768 kHz external crystal oscillator.
3. RTC clock is LSE divided by 32.

Figure 15. Typical $I_{DD(AH)}$ vs. V_{DD} (LSI clock source)

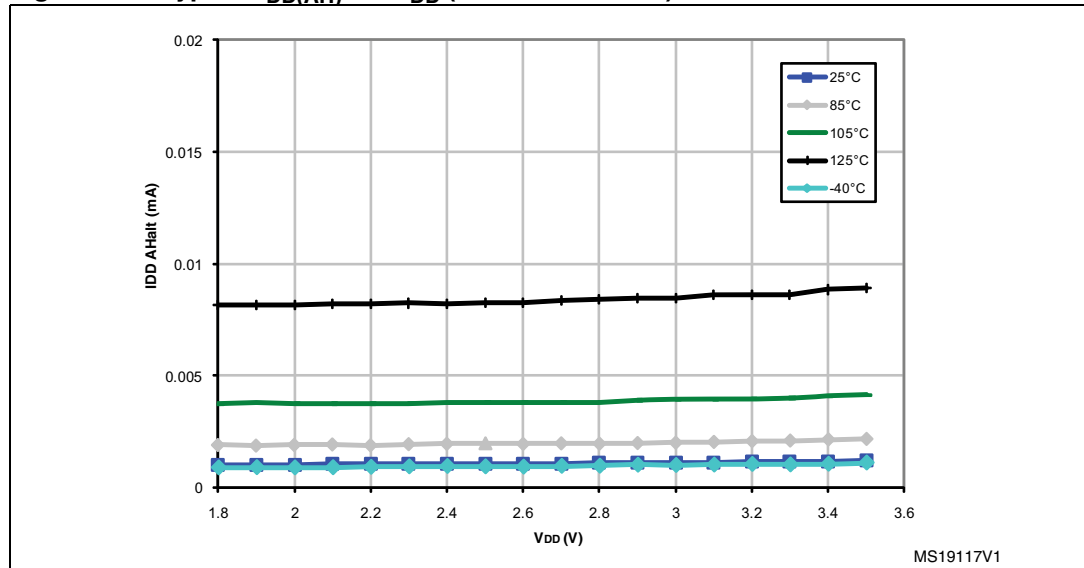

In the following table, data are based on characterization results, unless otherwise specified.

Table 25. Total current consumption and timing in Halt mode at V_{DD} = 1.65 to 3.6 V

Symbol	Parameter	Condition ⁽¹⁾	Typ.	Max.	Unit
I _{DD(Halt)}	Supply current in Halt mode (Ultra low power ULP bit =1 in the PWR_CSR2 register)	T _A = -40 °C to 25 °C	400	1600 ⁽²⁾	nA
		T _A = 55 °C	810	2400	
		T _A = 85 °C	1600	4500 ⁽²⁾	
		T _A = 105 °C	2900	7700 ⁽²⁾	
		T _A = 125 °C	5.6	18 ⁽²⁾	μA
I _{DD(WUHalt)}	Supply current during wakeup time from Halt mode (using HSI)		2.4		mA
t _{WU_HSI(Halt)} ⁽³⁾⁽⁴⁾	Wakeup time from Halt to Run mode (using HSI)		4.7	7	μs
t _{WU_LSI(Halt)} ⁽³⁾⁽⁴⁾	Wakeup time from Halt mode to Run mode (using LSI)		150		μs

1. T_A = -40 to 125 °C, no floating I/O, unless otherwise specified
2. Tested in production
3. ULP=0 or ULP=1 and FWU=1 in the PWR_CSR2 register
4. Wakeup time until start of interrupt vector fetch. The first word of interrupt routine is fetched 4 CPU cycles after t_{WU}

Figure 16. Typical I_{DD(Halt)} vs. V_{DD} (internal reference voltage OFF)

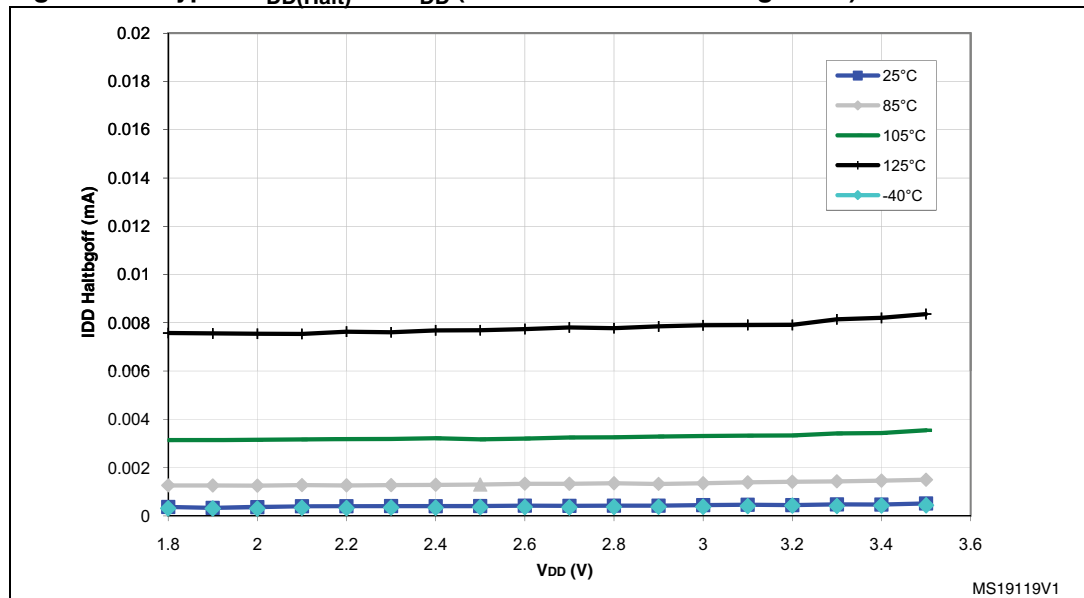

Current consumption of on-chip peripherals

Table 26. Peripheral current consumption

Symbol	Parameter	Typ. V _{DD} = 3.0 V	Unit	
I _{DD} (TIM1)	TIM1 supply current ⁽¹⁾	10	μA/MHz	
I _{DD} (TIM2)	TIM2 supply current ⁽¹⁾	7		
I _{DD} (TIM3)	TIM3 supply current ⁽¹⁾	7		
I _{DD} (TIM5)	TIM5 supply current ⁽¹⁾	7		
I _{DD} (TIM4)	TIM4 timer supply current ⁽¹⁾	3		
I _{DD} (USART1)	USART1 supply current ⁽²⁾	5		
I _{DD} (USART2)	USART2 supply current ⁽³⁾	5		
I _{DD} (USART3)	USART3 supply current ⁽⁴⁾	5		
I _{DD} (SPI1)	SPI1 supply current ⁽¹⁾	3		
I _{DD} (SPI2)	SPI2 supply current ⁽¹⁾	3		
I _{DD} (I2C1)	I ² C1 supply current ⁽¹⁾	4		
I _{DD} (DMA1)	DMA1 supply current	3		
I _{DD} (AES)	AES supply current	4		
I _{DD} (WWDG)	WWDG supply current	1		
I _{DD} (ALL)	Peripherals ON ⁽⁵⁾	67	μA	
I _{DD} (ADC1)	ADC1 supply current ⁽⁶⁾	1500		
I _{DD} (DAC)	DAC supply current ⁽⁷⁾	370		
I _{DD} (COMP1)	Comparator 1 supply current ⁽⁸⁾	0.160		
I _{DD} (COMP2)	Comparator 2 supply current ⁽⁸⁾	Slow mode		2
		Fast mode		5
I _{DD} (PVD/BOR)	Power voltage detector and brownout Reset unit supply current ⁽⁹⁾	2.6		
I _{DD} (BOR)	Brownout Reset unit supply current ⁽⁹⁾	2.4		
I _{DD} (IDWDG)	Independent watchdog supply current	including LSI supply current		0.45
		excluding LSI supply current		0.05

1. Data based on a differential I_{DD} measurement between all peripherals OFF and a timer counter running at 16 MHz. The CPU is in Wait mode in both cases. No IC/OC programmed, no I/O pins toggling. Not tested in production.
2. Data based on a differential I_{DD} measurement between the on-chip peripheral in reset configuration and not clocked and the on-chip peripheral when clocked and not kept under reset. The CPU is in Wait mode in both cases. No I/O pins toggling. Not tested in production.

3. Data based on a differential I_{DD} measurement between the on-chip peripheral in reset configuration and not clocked and the on-chip peripheral when clocked and not kept under reset. The CPU is in Wait mode in both cases. No I/O pins toggling. Not tested in production.
4. Data based on a differential I_{DD} measurement between the on-chip peripheral in reset configuration and not clocked and the on-chip peripheral when clocked and not kept under reset. The CPU is in Wait mode in both cases. No I/O pins toggling. Not tested in production.
5. Peripherals listed above the $I_{DD(ALL)}$ parameter ON: TIM1, TIM2, TIM3, TIM4, USART1, SPI1, I2C1, DMA1, WWDG.
6. Data based on a differential I_{DD} measurement between ADC in reset configuration and continuous ADC conversion.
7. Data based on a differential I_{DD} measurement between DAC in reset configuration and continuous DAC conversion of $V_{DD}/2$. Floating DAC output.
8. Data based on a differential I_{DD} measurement between COMP1 or COMP2 in reset configuration and COMP1 or COMP2 enabled with static inputs. Supply current of internal reference voltage excluded.
9. Including supply current of internal reference voltage.

Table 27. Current consumption under external reset

Symbol	Parameter	Conditions	Typ.	Unit	
$I_{DD(RST)}$	Supply current under external reset ⁽¹⁾	PB1/PB3/PA5 pins are externally tied to V_{DD}	$V_{DD} = 1.8\text{ V}$	48	μA
			$V_{DD} = 3\text{ V}$	80	
			$V_{DD} = 3.6\text{ V}$	95	

1. All pins except PA0, PB0 and PB4 are floating under reset. PA0, PB0 and PB4 are configured with pull-up under reset. PB1, PB3 and PA5 must be tied externally under reset to avoid the consumption due to their schmitt trigger.

9.3.4 Clock and timing characteristics

HSE external clock (HSEBYP = 1 in CLK_ECKCR)

Subject to general operating conditions for V_{DD} and T_A .

Table 28. HSE external clock characteristics

Symbol	Parameter	Conditions	Min.	Typ.	Max.	Unit
$f_{HSE_ext}^{(1)}$	External clock source frequency		1		16	MHz
V_{HSEH}	OSC_IN input pin high level voltage		$0.7 \times V_{DD}$		V_{DD}	V
V_{HSEL}	OSC_IN input pin low level voltage		V_{SS}		$0.3 \times V_{DD}$	
$C_{in(HSE)}^{(1)}$	OSC_IN input capacitance			2.6		pF
I_{LEAK_HSE}	OSC_IN input leakage current	$V_{SS} < V_{IN} < V_{DD}$			± 1	μA

1. Guaranteed by design, not tested in production.

LSE external clock (LSEBYP=1 in CLK_ECKCR)

Subject to general operating conditions for V_{DD} and T_A .

Table 29. LSE external clock characteristics

Symbol	Parameter	Min.	Typ.	Max.	Unit
$f_{LSE_ext}^{(1)}$	External clock source frequency		32.768		kHz
$V_{LSEH}^{(2)}$	OSC32_IN input pin high level voltage	$0.7 \times V_{DD}$		V_{DD}	V
$V_{LSEL}^{(2)}$	OSC32_IN input pin low level voltage	V_{SS}		$0.3 \times V_{DD}$	
$C_{in(LSE)}^{(1)}$	OSC32_IN input capacitance		0.6		pF
I_{LEAK_LSE}	OSC32_IN input leakage current			± 1	μA

1. Guaranteed by design, not tested in production.
2. Data based on characterization results, not tested in production.

HSE crystal/ceramic resonator oscillator

The HSE clock can be supplied with a 1 to 16 MHz crystal/ceramic resonator oscillator. All the information given in this paragraph is based on characterization results with specified typical external components. In the application, the resonator and the load capacitors have to be placed as close as possible to the oscillator pins in order to minimize output distortion and startup stabilization time. Refer to the crystal resonator manufacturer for more details (frequency, package, accuracy...).

Table 30. HSE oscillator characteristics

Symbol	Parameter	Conditions	Min.	Typ.	Max.	Unit
f_{HSE}	High speed external oscillator frequency		1		16	MHz
R_F	Feedback resistor			200		k Ω
$C^{(1)(2)}$	Recommended load capacitance			20		pF
$I_{DD(HSE)}$	HSE oscillator power consumption	$C = 20$ pF, $f_{OSC} = 16$ MHz			2.5 (startup) 0.7 (stabilized) ⁽³⁾	mA
		$C = 10$ pF, $f_{OSC} = 16$ MHz			2.5 (startup) 0.46 (stabilized) ⁽³⁾	
g_m	Oscillator transconductance		$3.5^{(3)}$			mA/V
$t_{SU(HSE)}^{(4)}$	Startup time	V_{DD} is stabilized		1		ms

1. $C=C_{L1}=C_{L2}$ is approximately equivalent to 2 x crystal C_{LOAD} .
2. The oscillator selection can be optimized in terms of supply current using a high quality resonator with small R_m value. Refer to crystal manufacturer for more details
3. Guaranteed by design. Not tested in production.
4. $t_{SU(HSE)}$ is the startup time measured from the moment it is enabled (by software) to a stabilized 16 MHz oscillation. This value is measured for a standard crystal resonator and it can vary significantly with the crystal manufacturer.

Figure 17. HSE oscillator circuit diagram

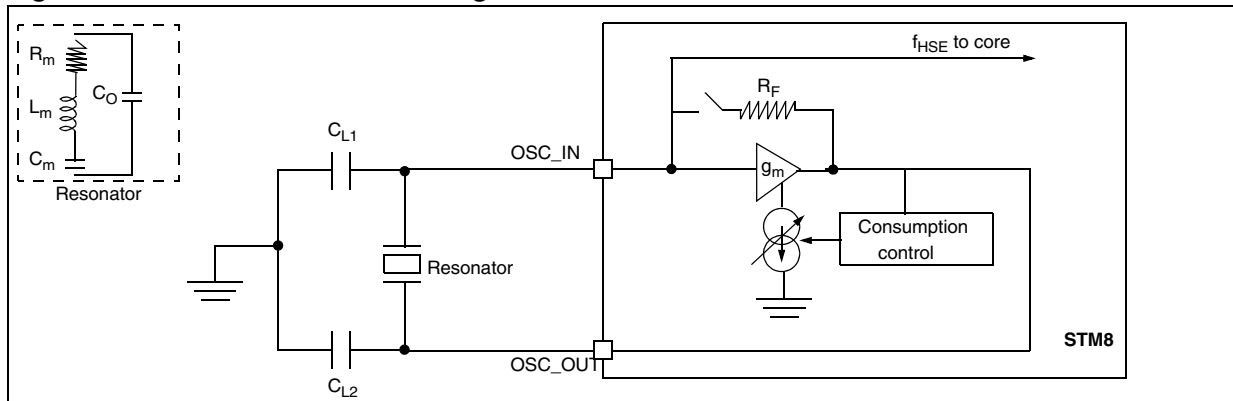

HSE oscillator critical gm formula

$$g_{m\text{crit}} = (2 \times \Pi \times f_{\text{HSE}})^2 \times R_m(2C_o + C)^2$$

R_m: Motional resistance (see crystal specification), L_m: Motional inductance (see crystal specification), C_m: Motional capacitance (see crystal specification), Co: Shunt capacitance (see crystal specification), C_{L1}=C_{L2}=C: Grounded external capacitance
 gm >> gm_{crit}

LSE crystal/ceramic resonator oscillator

The LSE clock can be supplied with a 32.768 kHz crystal/ceramic resonator oscillator. All the information given in this paragraph is based on characterization results with specified typical external components. In the application, the resonator and the load capacitors have to be placed as close as possible to the oscillator pins in order to minimize output distortion and startup stabilization time. Refer to the crystal resonator manufacturer for more details (frequency, package, accuracy...).

Table 31. LSE oscillator characteristics

Symbol	Parameter	Conditions	Min.	Typ.	Max.	Unit
f _{LSE}	Low speed external oscillator frequency			32.768		kHz
R _F	Feedback resistor	ΔV = 200 mV		1.2		MΩ
C ⁽¹⁾⁽²⁾	Recommended load capacitance			8		pF
I _{DD(LSE)}	LSE oscillator power consumption	V _{DD} = 1.8 V		450		nA
		V _{DD} = 3 V		600		
		V _{DD} = 3.6 V		750		
g _m	Oscillator transconductance		3 ⁽³⁾			μA/V
t _{SU(LSE)} ⁽⁴⁾	Startup time	V _{DD} is stabilized		1		s

- C=C_{L1}=C_{L2} is approximately equivalent to 2 x crystal C_{LOAD}.
- The oscillator selection can be optimized in terms of supply current using a high quality resonator with a small R_m value. Refer to crystal manufacturer for more details.
- Guaranteed by design. Not tested in production.
- t_{SU(LSE)} is the startup time measured from the moment it is enabled (by software) to a stabilized 32.768 kHz oscillation. This value is measured for a standard crystal resonator and it can vary significantly with the crystal manufacturer.

Figure 18. LSE oscillator circuit diagram

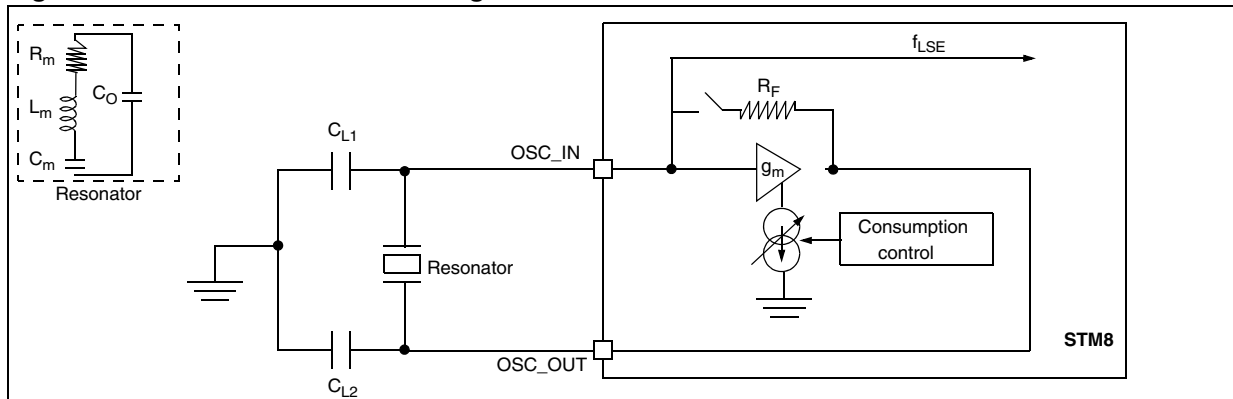

Internal clock sources

Subject to general operating conditions for V_{DD} , and T_A .

High speed internal RC oscillator (HSI)

In the following table, data are based on characterization results, not tested in production, unless otherwise specified.

Table 32. HSI oscillator characteristics

Symbol	Parameter	Conditions ⁽¹⁾	Min.	Typ.	Max.	Unit
f_{HSI}	Frequency	$V_{DD} = 3.0\text{ V}$		16		MHz
ACC_{HSI}	Accuracy of HSI oscillator (factory calibrated)	$V_{DD} = 3.0\text{ V}, T_A = 25\text{ }^\circ\text{C}$	-1 ⁽²⁾		1 ⁽²⁾	%
		$V_{DD} = 3.0\text{ V}, 0\text{ }^\circ\text{C} \leq T_A \leq 55\text{ }^\circ\text{C}$	-1.5		1.5	%
		$V_{DD} = 3.0\text{ V}, -10\text{ }^\circ\text{C} \leq T_A \leq 70\text{ }^\circ\text{C}$	-2		2	%
		$V_{DD} = 3.0\text{ V}, -10\text{ }^\circ\text{C} \leq T_A \leq 85\text{ }^\circ\text{C}$	-2.5		2	%
		$V_{DD} = 3.0\text{ V}, -10\text{ }^\circ\text{C} \leq T_A \leq 125\text{ }^\circ\text{C}$	-4.5		2	%
		$1.65\text{ V} \leq V_{DD} \leq 3.6\text{ V}, -40\text{ }^\circ\text{C} \leq T_A \leq 125\text{ }^\circ\text{C}$	-4.5		3	%
TRIM	HSI user trimming step ⁽³⁾	Trimming code \neq multiple of 16		0.4	0.7	%
		Trimming code = multiple of 16			± 1.5	%
$t_{su(HSI)}$	HSI oscillator setup time (wakeup time)			3.7	6 ⁽⁴⁾	μs
$I_{DD(HSI)}$	HSI oscillator power consumption			100	140 ⁽⁴⁾	μA

- $V_{DD} = 3.0\text{ V}, T_A = -40\text{ to }125\text{ }^\circ\text{C}$ unless otherwise specified.
- Tested in production.
- The trimming step differs depending on the trimming code. It is usually negative on the codes which are multiples of 16 (0x00, 0x10, 0x20, 0x30...0xE0). Refer to the AN3101 "STM8L15x internal RC oscillator calibration" application note for more details.
- Guaranteed by design, not tested in production

Figure 19. Typical HSI frequency vs. V_{DD}

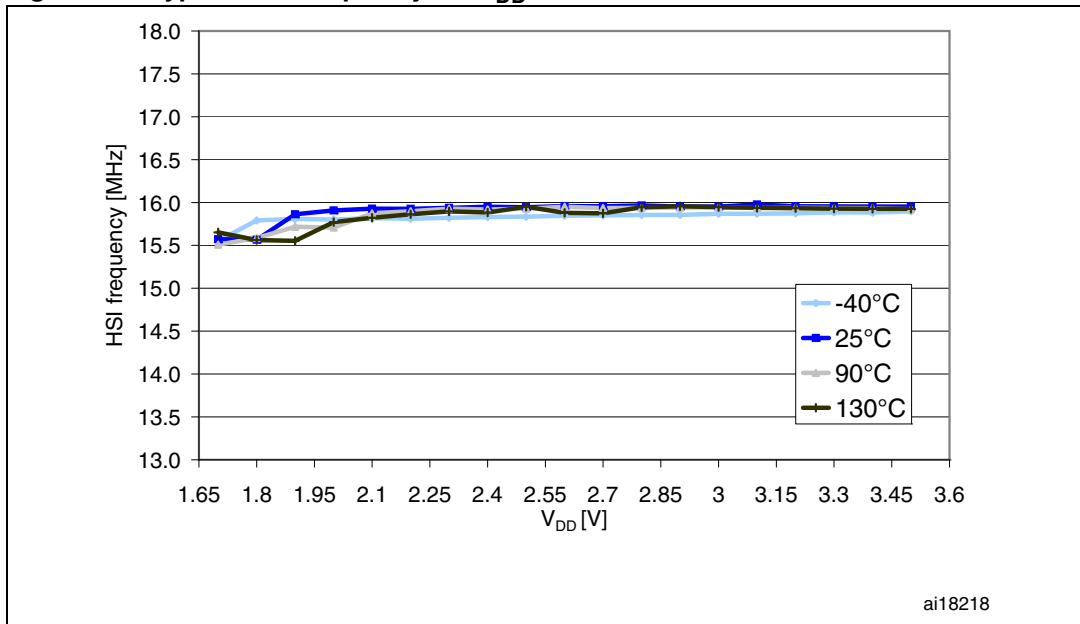

Low speed internal RC oscillator (LSI)

In the following table, data are based on characterization results, not tested in production.

Table 33. LSI oscillator characteristics

Symbol	Parameter	Conditions ⁽¹⁾	Min.	Typ.	Max.	Unit
f _{LSI}	Frequency		26	38	56	kHz
t _{su(LSI)}	LSI oscillator wakeup time				200 ⁽²⁾	µs
D _(LSI)	LSI oscillator frequency drift ⁽³⁾	0 °C ≤ T _A ≤ 85 °C	-12		11	%

1. V_{DD} = 1.65 V to 3.6 V, T_A = -40 to 125 °C unless otherwise specified.
2. Guaranteed by Design, not tested in production.
3. This is a deviation for an individual part, once the initial frequency has been measured.

Figure 20. Typical LSI clock source frequency vs. V_{DD}

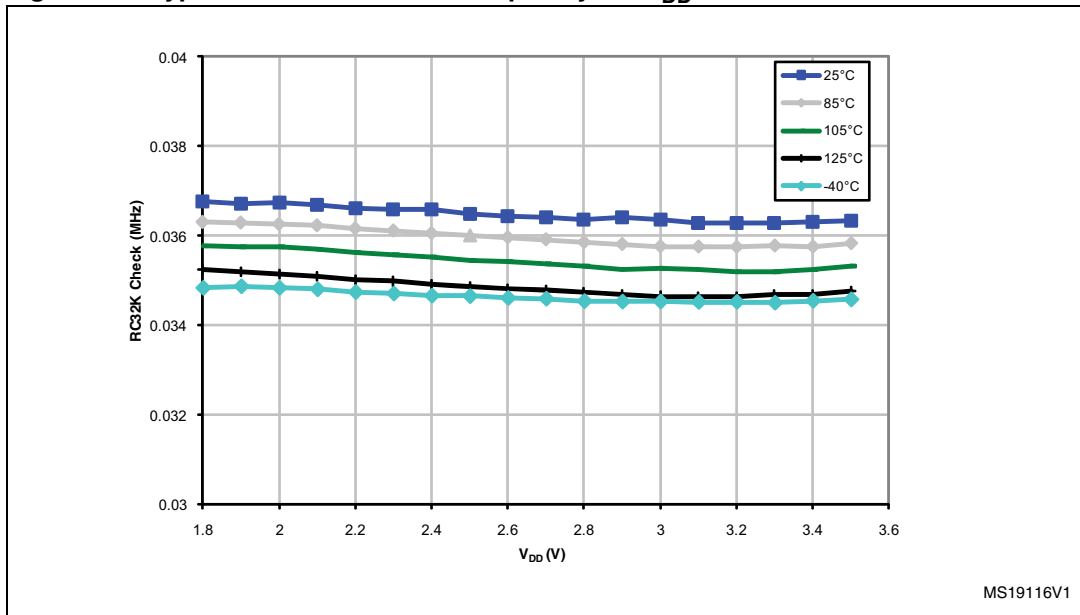

MS19116V1

9.3.5 Memory characteristics

T_A = -40 to 125 °C unless otherwise specified.

Table 34. RAM and hardware registers

Symbol	Parameter	Conditions	Min.	Typ.	Max.	Unit
V _{RM}	Data retention mode ⁽¹⁾	Halt mode (or Reset)	1.65			V

1. Minimum supply voltage without losing data stored in RAM (in Halt mode or under Reset) or in hardware registers (only in Halt mode). Guaranteed by characterization, not tested in production.

Flash memory

Table 35. Flash program and data EEPROM memory

Symbol	Parameter	Conditions	Min.	Typ.	Max. (1)	Unit
V _{DD}	Operating voltage (all modes, read/write/erase)	f _{SYSCLK} = 16 MHz	1.65		3.6	V
t _{prog}	Programming time for 1 or 128 bytes (block) erase/write cycles (on programmed byte)			6		ms
	Programming time for 1 to 128 bytes (block) write cycles (on erased byte)			3		ms
I _{prog}	Programming/ erasing consumption	T _A =+25 °C, V _{DD} = 3.0 V		0.7		mA
		T _A =+25 °C, V _{DD} = 1.8 V				
t _{RET} ⁽²⁾	Data retention (program memory) after 10000 erase/write cycles at T _A =-40 to +85 °C (6 suffix)	T _{RET} =+85 °C	30 ⁽¹⁾			years
	Data retention (program memory) after 10000 erase/write cycles at T _A =-40 to +125 °C (3 suffix)	T _{RET} =+125 °C	5 ⁽¹⁾			
	Data retention (data memory) after 300000 erase/write cycles at T _A =-40 to +85 °C (6 suffix)	T _{RET} =+85 °C	30 ⁽¹⁾			
	Data retention (data memory) after 300000 erase/write cycles at T _A =-40 to +125 °C (3 suffix)	T _{RET} =+125 °C	5 ⁽¹⁾			
N _{RW} ⁽³⁾	Erase/write cycles (program memory)	T _A =-40 to +85 °C (6 suffix), T _A =-40 to +105 °C (7 suffix) or T _A =-40 to +125 °C (3 suffix)	10 ⁽¹⁾			kcycles
	Erase/write cycles (data memory)		300 ⁽¹⁾ ⁽⁴⁾			

1. Data based on characterization results, not tested in production.
2. Conforming to JEDEC JESD22a117
3. The physical granularity of the memory is 4 bytes, so cycling is performed on 4 bytes even when a write/erase operation addresses a single byte.
4. Data based on characterization performed on the whole data memory.

9.3.6 I/O current injection characteristics

As a general rule, current injection to the I/O pins, due to external voltage below V_{SS} or above V_{DD} (for standard pins) should be avoided during normal product operation. However, in order to give an indication of the robustness of the microcontroller in cases when abnormal injection accidentally happens, susceptibility tests are performed on a sample basis during device characterization.

Functional susceptibility to I/O current injection

While a simple application is executed on the device, the device is stressed by injecting current into the I/O pins programmed in floating input mode. While current is injected into the I/O pin, one at a time, the device is checked for functional failures.

The failure is indicated by an out of range parameter: ADC error, out of spec current injection on adjacent pins or other functional failure (for example reset, oscillator frequency deviation, LCD levels, etc.).

The test results are given in the following table.

Table 36. I/O current injection susceptibility

Symbol	Description	Functional susceptibility		Unit
		Negative injection	Positive injection	
I_{INJ}	Injected current on true open-drain pins	-5	+0	mA
	Injected current on all 5 V tolerant (FT) pins	-5	+0	
	Injected current on any other pin	-5	+5	

9.3.7 I/O port pin characteristics

General characteristics

Subject to general operating conditions for V_{DD} and T_A unless otherwise specified. All unused pins must be kept at a fixed voltage: using the output mode of the I/O for example or an external pull-up or pull-down resistor.

Table 37. I/O static characteristics

Symbol	Parameter	Conditions ⁽¹⁾	Min.	Typ.	Max.	Unit
V _{IL}	Input low level voltage ⁽²⁾	Input voltage on true open-drain pins (PC0 and PC1)	V _{SS} -0.3		0.3 x V _{DD}	V
		Input voltage on five-volt tolerant (FT) pins	V _{SS} -0.3		0.3 x V _{DD}	
		Input voltage on any other pin	V _{SS} -0.3		0.3 x V _{DD}	
V _{IH}	Input high level voltage ⁽²⁾	Input voltage on true open-drain pins (PC0 and PC1) with V _{DD} < 2 V	0.70 x V _{DD}		5.2	V
		Input voltage on true open-drain pins (PC0 and PC1) with V _{DD} ≥ 2 V			5.5	
		Input voltage on five-volt tolerant (FT) pins with V _{DD} < 2 V	0.70 x V _{DD}		5.2	
		Input voltage on five-volt tolerant (FT) pins with V _{DD} ≥ 2 V			5.5	
		Input voltage on any other pin	0.70 x V _{DD}		V _{DD} +0.3	
V _{hys}	Schmitt trigger voltage hysteresis ⁽³⁾	Standard I/Os		200		mV
		True open drain I/Os		200		
I _{lkg}	Input leakage current ⁽⁴⁾	V _{SS} ≤ V _{IN} ≤ V _{DD} Standard I/Os	-	-	50 ⁽⁵⁾	nA
		V _{SS} ≤ V _{IN} ≤ V _{DD} True open drain I/Os	-	-	200 ⁽⁵⁾	
		V _{SS} ≤ V _{IN} ≤ V _{DD} PA0 with high sink LED driver capability	-	-	200 ⁽⁵⁾	
R _{PU}	Weak pull-up equivalent resistor ⁽²⁾⁽⁶⁾	V _{IN} =V _{SS}	30	45	60	kΩ
C _{IO}	I/O pin capacitance			5		pF

1. V_{DD} = 3.0 V, T_A = -40 to 125 °C unless otherwise specified.
2. Data based on characterization results, not tested in production.
3. Hysteresis voltage between Schmitt trigger switching levels. Based on characterization results, not tested.
4. The max. value may be exceeded if negative current is injected on adjacent pins.
5. Not tested in production.
6. R_{PU} pull-up equivalent resistor based on a resistive transistor (corresponding I_{PU} current characteristics described in Figure 24).

Figure 21. Typical V_{IL} and V_{IH} vs. V_{DD} (standard I/Os)

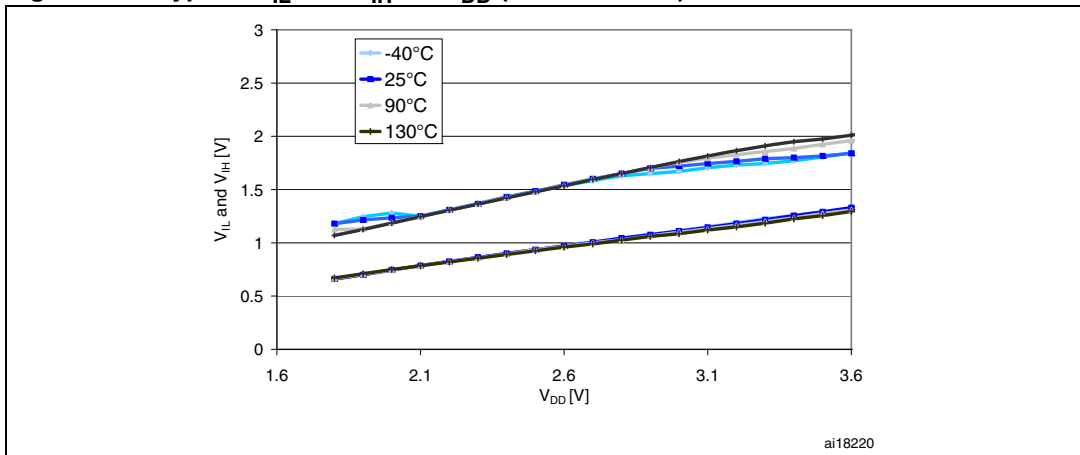

Figure 22. Typical V_{IL} and V_{IH} vs. V_{DD} (true open drain I/Os)

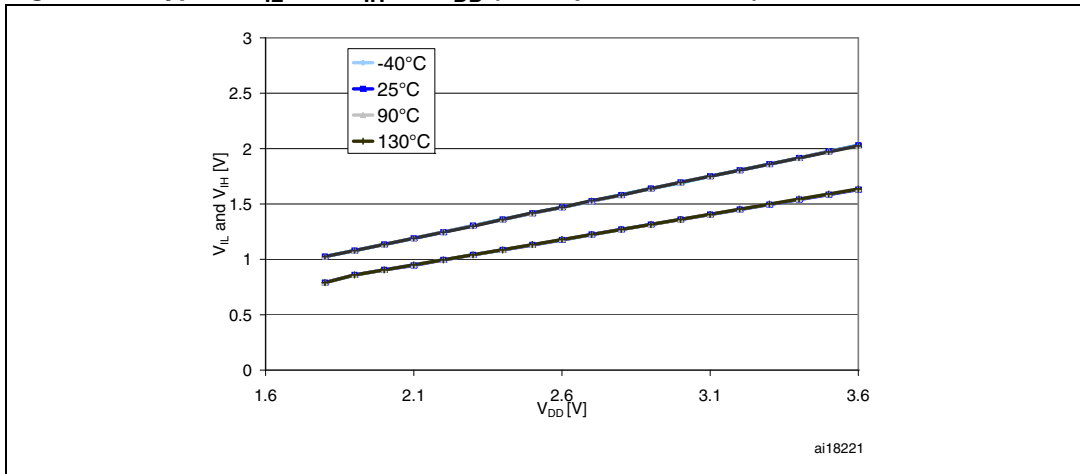

Figure 23. Typical pull-up resistance R_{PU} vs. V_{DD} with $V_{IN}=V_{SS}$

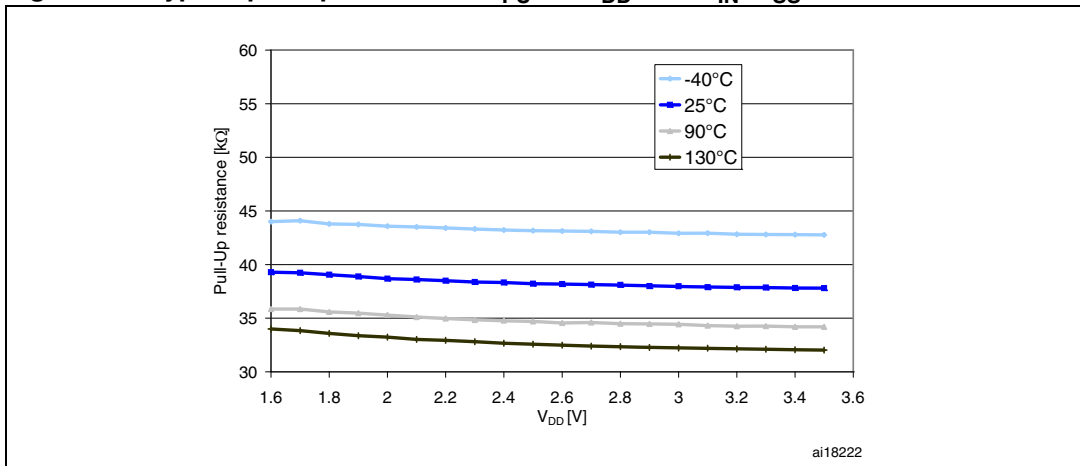
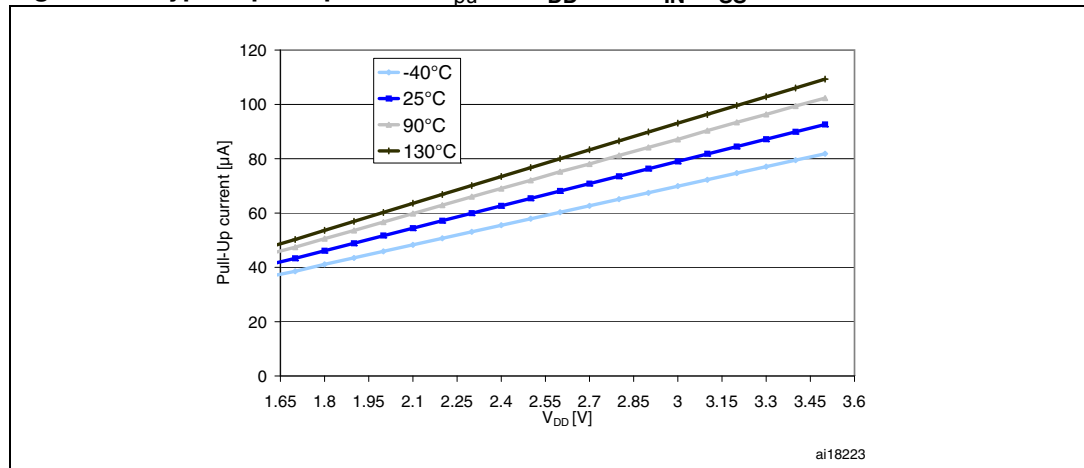

Figure 24. Typical pull-up current I_{DU} vs. V_{DD} with $V_{IN}=V_{SS}$



Output driving current

Subject to general operating conditions for V_{DD} and T_A unless otherwise specified.

Table 38. Output driving current (high sink ports)

I/O Type	Symbol	Parameter	Conditions	Min.	Max.	Unit
Standard	$V_{OL}^{(1)}$	Output low level voltage for an I/O pin	$I_{IO} = +2 \text{ mA}$, $V_{DD} = 3.0 \text{ V}$		0.45	V
			$I_{IO} = +2 \text{ mA}$, $V_{DD} = 1.8 \text{ V}$		0.45	V
			$I_{IO} = +10 \text{ mA}$, $V_{DD} = 3.0 \text{ V}$		0.7	V
	$V_{OH}^{(2)}$	Output high level voltage for an I/O pin	$I_{IO} = -2 \text{ mA}$, $V_{DD} = 3.0 \text{ V}$	$V_{DD}-0.45$		V
			$I_{IO} = -1 \text{ mA}$, $V_{DD} = 1.8 \text{ V}$	$V_{DD}-0.45$		V
			$I_{IO} = -10 \text{ mA}$, $V_{DD} = 3.0 \text{ V}$	$V_{DD}-0.7$		V

1. The I_{IO} current sunk must always respect the absolute maximum rating specified in [Table 15](#) and the sum of I_{IO} (I/O ports and control pins) must not exceed I_{VSS} .
2. The I_{IO} current sourced must always respect the absolute maximum rating specified in [Table 15](#) and the sum of I_{IO} (I/O ports and control pins) must not exceed I_{VDD} .

Table 39. Output driving current (true open drain ports)

I/O Type	Symbol	Parameter	Conditions	Min.	Max.	Unit
Open drain	$V_{OL}^{(1)}$	Output low level voltage for an I/O pin	$I_{IO} = +3 \text{ mA}$, $V_{DD} = 3.0 \text{ V}$		0.45	V
			$I_{IO} = +1 \text{ mA}$, $V_{DD} = 1.8 \text{ V}$		0.45	

1. The I_{IO} current sunk must always respect the absolute maximum rating specified in [Table 15](#) and the sum of I_{IO} (I/O ports and control pins) must not exceed I_{VSS} .

Table 40. Output driving current (PA0 with high sink LED driver capability)

I/O Type	Symbol	Parameter	Conditions	Min.	Max.	Unit
$\overline{\text{PE}}$	$V_{OL}^{(1)}$	Output low level voltage for an I/O pin	$I_{IO} = +20 \text{ mA}$, $V_{DD} = 2.0 \text{ V}$		0.45	V

1. The I_{IO} current sunk must always respect the absolute maximum rating specified in [Table 15](#) and the sum of I_{IO} (I/O ports and control pins) must not exceed I_{VSS} .

Figure 25. Typical V_{OL} @ $V_{DD} = 3.0 \text{ V}$ (high sink ports)

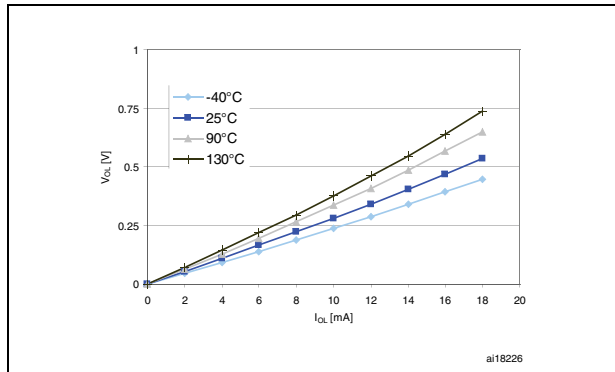

Figure 26. Typical V_{OL} @ $V_{DD} = 1.8 \text{ V}$ (high sink ports)

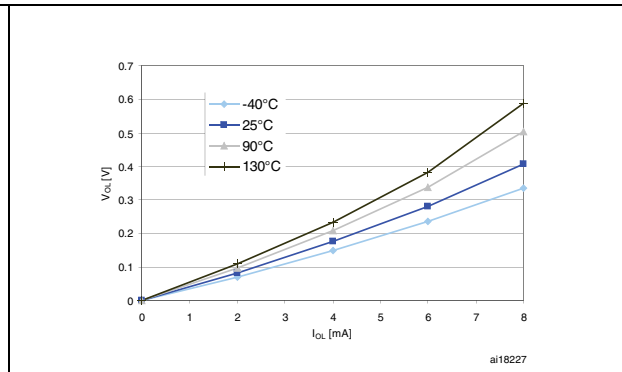

Figure 27. Typical V_{OL} @ $V_{DD} = 3.0 \text{ V}$ (true open drain ports)

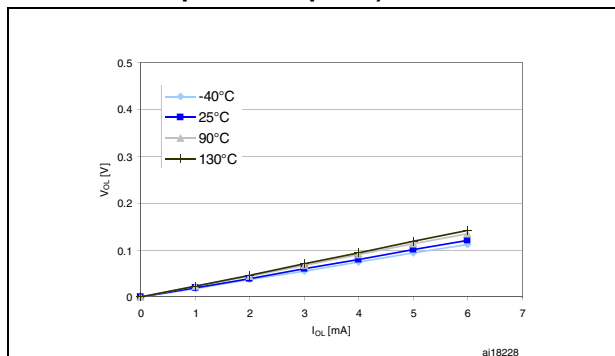

Figure 28. Typical V_{OL} @ $V_{DD} = 1.8 \text{ V}$ (true open drain ports)

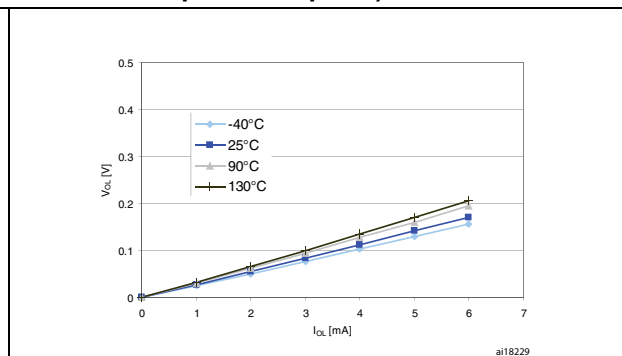

Figure 29. Typical $V_{DD} - V_{OH}$ @ $V_{DD} = 3.0\text{ V}$ (high sink ports)

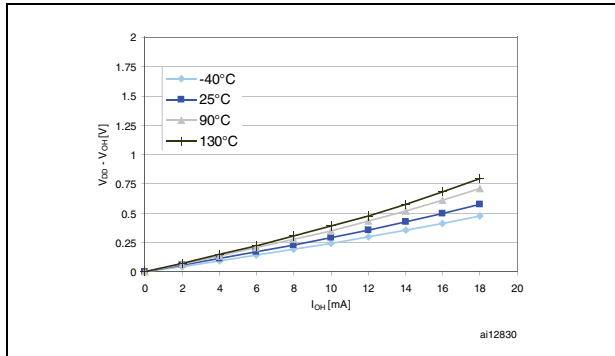
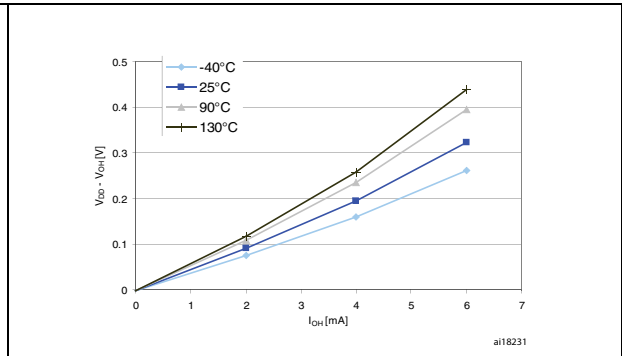

Figure 30. Typical $V_{DD} - V_{OH}$ @ $V_{DD} = 1.8\text{ V}$ (high sink ports)



NRST pin

Subject to general operating conditions for V_{DD} and T_A unless otherwise specified.

Table 41. **NRST** pin characteristics

Symbol	Parameter	Conditions	Min.	Typ.	Max.	Unit
$V_{IL(NRST)}$	NRST input low level voltage ⁽¹⁾		V_{SS}		0.8	V
$V_{IH(NRST)}$	NRST input high level voltage ⁽¹⁾		1.4		V_{DD}	
$V_{OL(NRST)}$	NRST output low level voltage ⁽¹⁾	$I_{OL} = 2\text{ mA}$ for $2.7\text{ V} \leq V_{DD} \leq 3.6\text{ V}$			0.4	V
		$I_{OL} = 1.5\text{ mA}$ for $V_{DD} < 2.7\text{ V}$				
V_{HYST}	NRST input hysteresis ⁽³⁾		$10\%V_{DD}$ (2)			mV
$R_{PU(NRST)}$	NRST pull-up equivalent resistor ⁽¹⁾		30	45	60	k Ω
$V_{F(NRST)}$	NRST input filtered pulse ⁽³⁾				50	ns
$V_{NF(NRST)}$	NRST input not filtered pulse ⁽³⁾		300			

1. Data based on characterization results, not tested in production.
2. 200 mV min.
3. Data guaranteed by design, not tested in production.

Figure 31. Typical NRST pull-up resistance R_{PU} vs. V_{DD}

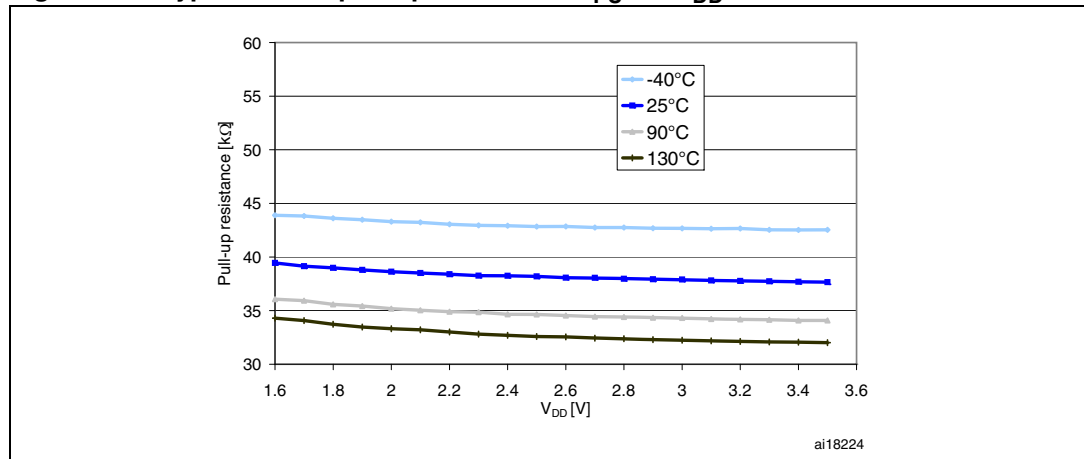
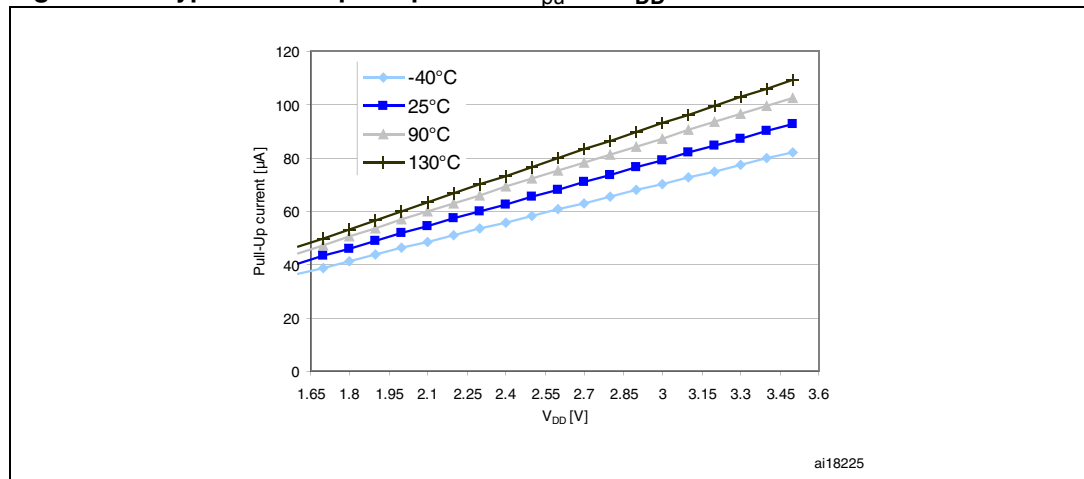
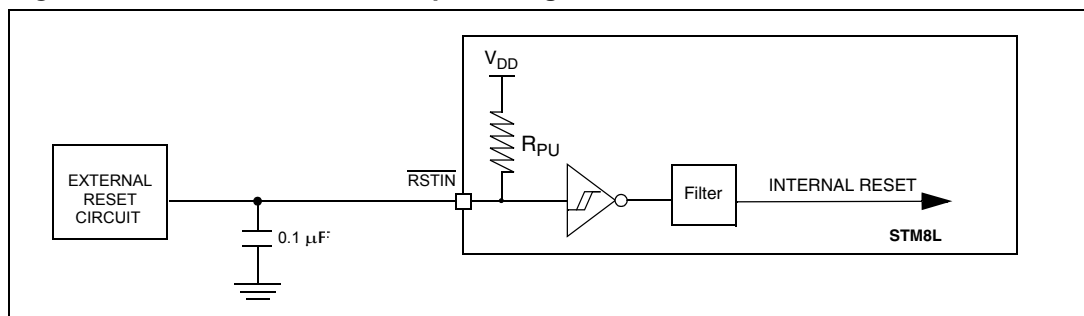

Figure 32. Typical NRST pull-up current I_{PU} vs. V_{DD}



The reset network shown in [Figure 33](#) protects the device against parasitic resets. The user must ensure that the level on the NRST pin can go below the V_{IL} max. level specified in [Table 41](#). Otherwise the reset is not taken into account internally. For power consumption-sensitive applications, the capacity of the external reset capacitor can be reduced to limit the charge/discharge current. If the NRST signal is used to reset the external circuitry, the user must pay attention to the charge/discharge time of the external capacitor to meet the reset timing conditions of the external devices. The minimum recommended capacity is 10 nF.

Figure 33. Recommended NRST pin configuration



9.3.8 Communication interfaces

SPI1 - Serial peripheral interface

Unless otherwise specified, the parameters given in [Table 42](#) are derived from tests performed under ambient temperature, f_{SYSCLK} frequency and V_{DD} supply voltage conditions summarized in [Section 9.3.1](#). Refer to I/O port characteristics for more details on the input/output alternate function characteristics (NSS, SCK, MOSI, MISO).

Table 42. SPI1 characteristics

Symbol	Parameter	Conditions ⁽¹⁾	Min.	Max.	Unit
f_{SCK} $1/t_{\text{c(SCK)}}$	SPI1 clock frequency	Master mode	0	8	MHz
		Slave mode	0	8	
$t_{\text{r(SCK)}}$ $t_{\text{f(SCK)}}$	SPI1 clock rise and fall time	Capacitive load: C = 30 pF	-	30	ns
$t_{\text{su(NSS)}}^{(2)}$	NSS setup time	Slave mode	$4 \times 1/f_{\text{SYSCLK}}$	-	
$t_{\text{h(NSS)}}^{(2)}$	NSS hold time	Slave mode	80	-	
$t_{\text{w(SCKH)}}^{(2)}$ $t_{\text{w(SCKL)}}^{(2)}$	SCK high and low time	Master mode, $f_{\text{MASTER}} = 8 \text{ MHz}$, $f_{\text{SCK}} = 4 \text{ MHz}$	105	145	
$t_{\text{su(MI)}}^{(2)}$ $t_{\text{su(SI)}}^{(2)}$	Data input setup time	Master mode	30	-	
		Slave mode	3	-	
$t_{\text{h(MI)}}^{(2)}$ $t_{\text{h(SI)}}^{(2)}$	Data input hold time	Master mode	15	-	
		Slave mode	0	-	
$t_{\text{a(SO)}}^{(2)(3)}$	Data output access time	Slave mode	-	$3 \times 1/f_{\text{SYSCLK}}$	
$t_{\text{dis(SO)}}^{(2)(4)}$	Data output disable time	Slave mode	30	-	
$t_{\text{v(SO)}}^{(2)}$	Data output valid time	Slave mode (after enable edge)	-	60	
$t_{\text{v(MO)}}^{(2)}$	Data output valid time	Master mode (after enable edge)	-	20	
$t_{\text{h(SO)}}^{(2)}$	Data output hold time	Slave mode (after enable edge)	15	-	
$t_{\text{h(MO)}}^{(2)}$		Master mode (after enable edge)	1	-	

- Parameters are given by selecting 10 MHz I/O output frequency.
- Values based on design simulation and/or characterization results, and not tested in production.
- Min. time is for the minimum time to drive the output and max. time is for the maximum time to validate the data.
- Min. time is for the minimum time to invalidate the output and max. time is for the maximum time to put the data in Hi-Z.

Figure 34. SPI1 timing diagram - slave mode and CPHA=0

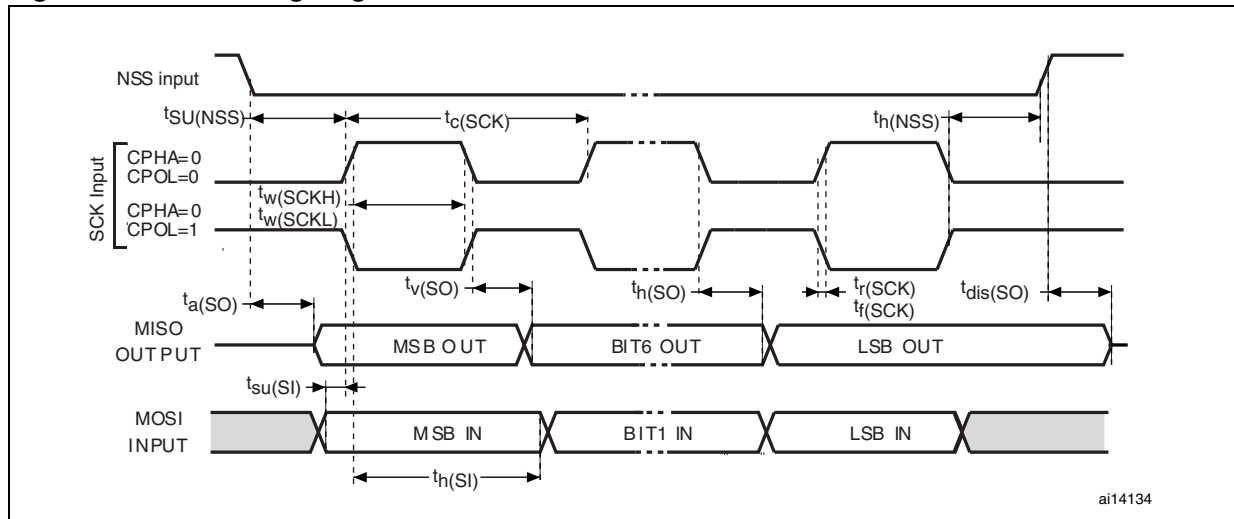
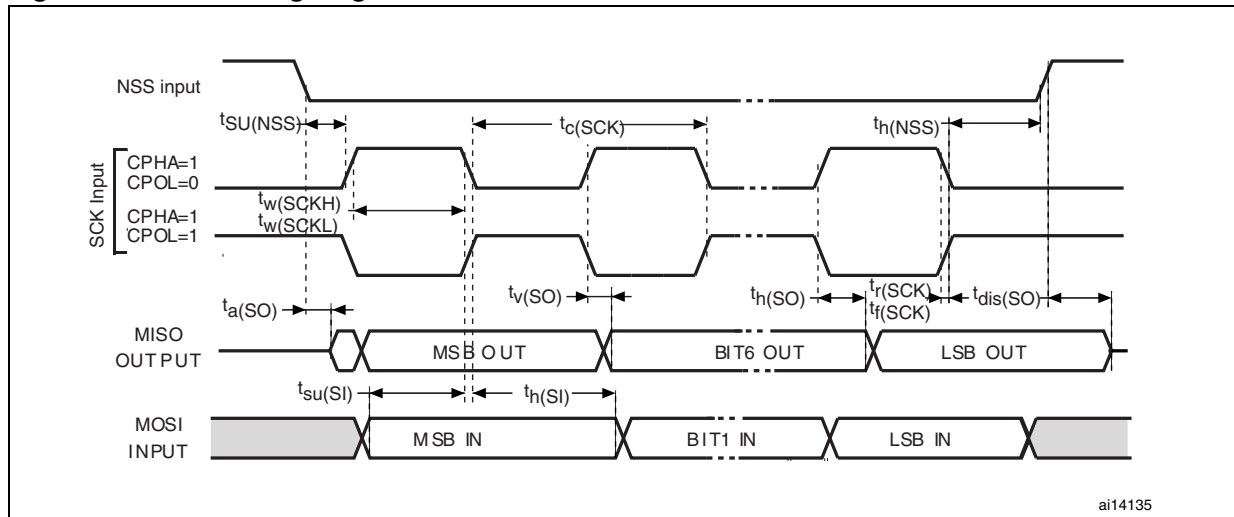
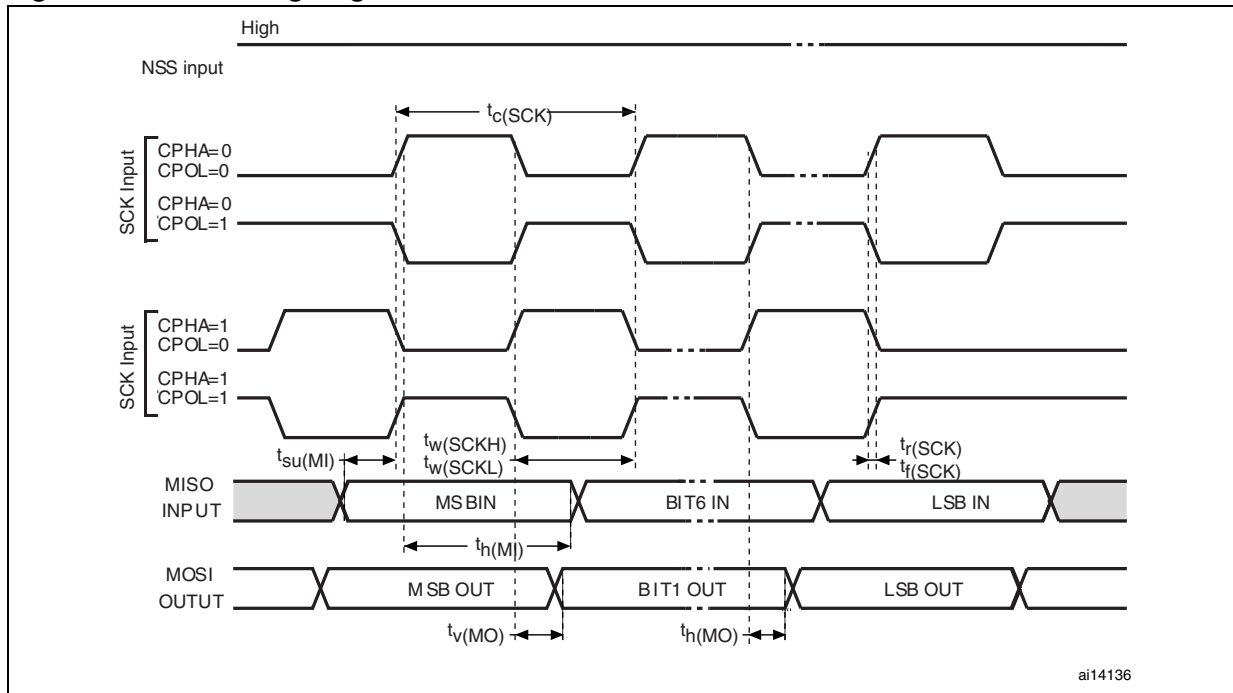

Figure 35. SPI1 timing diagram - slave mode and CPHA=1



1. Measurement points are done at CMOS levels: $0.3V_{DD}$ and $0.7V_{DD}$.

Figure 36. SPI1 timing diagram - master mode



1. Measurement points are done at CMOS levels: $0.3V_{DD}$ and $0.7V_{DD}$.

I²C - Inter IC control interface

Subject to general operating conditions for V_{DD} , f_{SYSCLK} , and T_A unless otherwise specified.

The STM8L I²C interface (I2C1) meets the requirements of the Standard I²C communication protocol described in the following table with the restriction mentioned below:

Refer to I/O port characteristics for more details on the input/output alternate function characteristics (SDA and SCL).

Table 43. I2C characteristics

Symbol	Parameter	Standard mode I ² C		Fast mode I ² C ⁽¹⁾		Unit
		Min. ⁽²⁾	Max. ⁽²⁾	Min. ⁽²⁾	Max. ⁽²⁾	
$t_{w(SCLL)}$	SCL clock low time	4.7		1.3		μs
$t_{w(SCLH)}$	SCL clock high time	4.0		0.6		
$t_{su(SDA)}$	SDA setup time	250		100		ns
$t_{h(SDA)}$	SDA data hold time	0		0	900	
$t_{r(SDA)}$ $t_{r(SCL)}$	SDA and SCL rise time		1000		300	
$t_{f(SDA)}$ $t_{f(SCL)}$	SDA and SCL fall time		300		300	
$t_{h(STA)}$	START condition hold time	4.0		0.6		μs
$t_{su(STA)}$	Repeated START condition setup time	4.7		0.6		
$t_{su(STO)}$	STOP condition setup time	4.0		0.6		μs
$t_{w(STO:STA)}$	STOP to START condition time (bus free)	4.7		1.3		μs
C_b	Capacitive load for each bus line		400		400	pF

1. f_{SYSCLK} must be at least equal to 8 MHz to achieve max fast I²C speed (400 kHz).

2. Data based on standard I²C protocol requirement, not tested in production.

Note: *For speeds around 200 kHz, the achieved speed can have a $\pm 5\%$ tolerance.
For other speed ranges, the achieved speed can have a $\pm 2\%$ tolerance.
The above variations depend on the accuracy of the external components used.*

Figure 37. Typical application with I²C bus and timing diagram

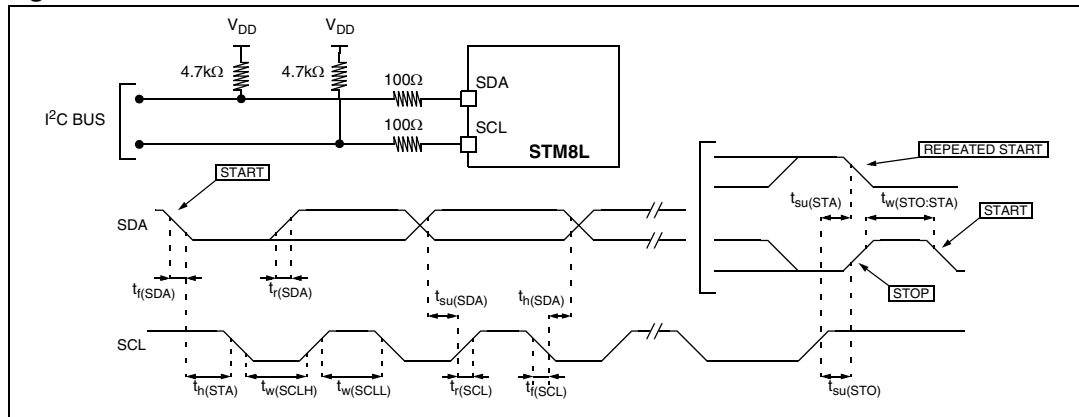

1. Measurement points are done at CMOS levels: 0.3 x V_{DD} and 0.7 x V_{DD}

9.3.9 LCD controller

In the following table, data are guaranteed by Design, not tested in production.

Table 44. LCD characteristics

Symbol	Parameter	Min.	Typ.	Max.	Unit
V _{LCD}	LCD external voltage			3.6	V
V _{LCD0}	LCD internal reference voltage 0		2.6		
V _{LCD1}	LCD internal reference voltage 1		2.7		
V _{LCD2}	LCD internal reference voltage 2		2.8		
V _{LCD3}	LCD internal reference voltage 3		3.0		
V _{LCD4}	LCD internal reference voltage 4		3.1		
V _{LCD5}	LCD internal reference voltage 5		3.2		
V _{LCD6}	LCD internal reference voltage 6		3.4		
V _{LCD7}	LCD internal reference voltage 7		3.5		
C _{EXT}	V _{LCD} external capacitance	0.1	1	2	μF
I _{DD}	Supply current ⁽¹⁾ at V _{DD} = 1.8 V		3		μA
	Supply current ⁽¹⁾ at V _{DD} = 3 V		3		
R _{HN} ⁽²⁾	High value resistive network (low drive)		6.6		MΩ
R _{LN} ⁽³⁾	Low value resistive network (high drive)		240		kΩ
V ₃₃	Segment/Common higher level voltage			V _{LCDx}	V
V ₃₄	Segment/Common 3/4 level voltage		3/4V _{LCDx}		
V ₂₃	Segment/Common 2/3 level voltage		2/3V _{LCDx}		
V ₁₂	Segment/Common 1/2 level voltage		1/2V _{LCDx}		
V ₁₃	Segment/Common 1/3 level voltage		1/3V _{LCDx}		
V ₁₄	Segment/Common 1/4 level voltage		1/4V _{LCDx}		
V ₀	Segment/Common lowest level voltage	0			

1. LCD enabled with 3 V internal booster (LCD_CR1 = 0x08), 1/4 duty, 1/3 bias, division ratio= 64, all pixels active, no LCD connected.
2. R_{HN} is the total high value resistive network.
3. R_{LN} is the total low value resistive network.

VLCD external capacitor

The application can achieve a stabilized LCD reference voltage by connecting an external capacitor C_{EXT} to the V_{LCD} pin. C_{EXT} is specified in [Table 44](#).

9.3.10 Embedded reference voltage

In the following table, data are based on characterization results, not tested in production, unless otherwise specified.

Table 45. Reference voltage characteristics

Symbol	Parameter	Conditions	Min.	Typ.	Max.	Unit
I_{REFINT}	Internal reference voltage consumption			1.4		μA
$T_{S_VREFINT}^{(1)(2)}$	ADC sampling time when reading the internal reference voltage			5	10	μs
$I_{BUF}^{(1)}$	Internal reference voltage buffer consumption (used for ADC)			13.5	25	μA
$V_{REFINT\ out}$	Reference voltage output		1.202 ⁽³⁾	1.224	1.242 ⁽³⁾	V
$I_{LPBUF}^{(1)}$	Internal reference voltage low power buffer consumption (used for comparators or output)			730	1200	nA
$I_{REFOUT}^{(1)(4)}$	Buffer output current				1	μA
C_{REFOUT}	Reference voltage output load				50	pF
$t_{VREFINT}^{(1)}$	Internal reference voltage startup time			2	3	ms
$t_{BUFEN}^{(1)(2)}$	Internal reference voltage buffer startup time once enabled				10	μs
$ACC_{VREFINT}^{(5)}$	Accuracy of V_{REFINT} stored in the $VREFINT_Factory_CONV$ byte				± 5	mV
$STAB_{VREFINT}$	Stability of V_{REFINT} over temperature	$-40\text{ }^{\circ}\text{C} \leq T_A \leq 125\text{ }^{\circ}\text{C}$		20	50	ppm/ $^{\circ}\text{C}$
	Stability of V_{REFINT} over temperature	$0\text{ }^{\circ}\text{C} \leq T_A \leq 50\text{ }^{\circ}\text{C}$			20	ppm/ $^{\circ}\text{C}$
$STAB_{VREFINT}$	Stability of V_{REFINT} after 1000 hours				TBD	ppm

1. Guaranteed by design, not tested in production
2. Defined when ADC output reaches its final value $\pm 1/2\text{LSB}$
3. Tested in production at $V_{DD} = 3\text{ V} \pm 10\text{ mV}$.
4. To guarantee less than 1% V_{REFOUT} deviation
5. Measured at $V_{DD} = 3\text{ V} \pm 10\text{ mV}$. This value takes into account V_{DD} accuracy and ADC conversion accuracy.

9.3.11 Temperature sensor

In the following table, data are based on characterization results, not tested in production, unless otherwise specified.

Table 46. TS characteristics

Symbol	Parameter	Min.	Typ.	Max.	Unit
$V_{90}^{(1)}$	Sensor reference voltage at $90^{\circ}\text{C} \pm 5^{\circ}\text{C}$,	0.580	0.597	0.614	V
T_L	V_{SENSOR} linearity with temperature		± 1	± 2	$^{\circ}\text{C}$
Avg_slope ⁽²⁾	Average slope	1.59	1.62	1.65	mV/ $^{\circ}\text{C}$
$\text{IDD}_{(\text{TEMP})}^{(2)}$	Consumption		3.4	6	μA
$T_{\text{START}}^{(2)(3)}$	Temperature sensor startup time			10	μs
$T_{\text{S_TEMP}}^{(2)}$	ADC sampling time when reading the temperature sensor		5	10	μs

1. Tested in production at $V_{\text{DD}} = 3\text{ V} \pm 10\text{ mV}$. The 8 LSB of the V_{90} ADC conversion result are stored in the TS_Factory_CONV_V90 byte.
2. Guaranteed by design, not tested in production.
3. Defined for ADC output reaching its final value $\pm 1/2\text{LSB}$.

9.3.12 Comparator characteristics

In the following tables, data are guaranteed by design, not tested in production.

Table 47. Comparator 1 characteristics

Symbol	Parameter	Conditions	Min ⁽¹⁾	Typ	Max ⁽¹⁾	Unit
V _{DDA}	Analog supply voltage		1.65		3.6	V
R _{400K}	R _{400K} value			400		kΩ
R _{10K}	R _{10K} value			10		
V _{IN}	Comparator 1 input voltage range		0.6		V _{DDA}	V
t _{START}	Comparator startup time			7	10	μs
t _d	Propagation delay ⁽²⁾			3	10	
V _{offset}	Comparator offset			±3	±10	mV
d _{Voffset} /dt	Comparator offset variation in worst voltage stress conditions	V _{DDA} = 3.6 V V _{IN+} = 0 V V _{IN-} = V _{REFINT} T _A = 25 °C	0	1.5	10	mV/1000 h
I _{COMP1}	Current consumption ⁽³⁾			160	260	nA

1. Based on characterization, not tested in production.
2. The delay is characterized for 100 mV input step with 10 mV overdrive on the inverting input, the non-inverting input set to the reference.
3. Comparator consumption only. Internal reference voltage not included.

Table 48. Comparator 2 characteristics

Symbol	Parameter	Conditions	Min	Typ	Max ⁽¹⁾	Unit
V _{DDA}	Analog supply voltage		1.65		3.6	V
V _{IN}	Comparator 2 input voltage range		0		V _{DDA}	V
t _{START}	Comparator startup time	Fast mode		15	20	μs
		Slow mode		20	25	
t _{d slow}	Propagation delay ⁽²⁾ in slow mode	1.65 V ≤ V _{DDA} ≤ 2.7 V		1.8	3.5	
		2.7 V ≤ V _{DDA} ≤ 3.6 V		2.5	6	
t _{d fast}	Propagation delay ⁽²⁾ in fast mode	1.65 V ≤ V _{DDA} ≤ 2.7 V		0.8	2	
		2.7 V ≤ V _{DDA} ≤ 3.6 V		1.2	4	
V _{offset}	Comparator offset error			±4	±20	mV
dThreshold/dt	Threshold voltage temperature coefficient	V _{DDA} = 3.3V T _A = 0 to 50 °C V ₋ = V _{REF+} , 3/4 V _{REF+} , 1/2 V _{REF+} , 1/4 V _{REF+} .		15	30	ppm /°C
I _{COMP2}	Current consumption ⁽³⁾	Fast mode		3.5	5	μA
		Slow mode		0.5	2	

1. Based on characterization, not tested in production.

2. The delay is characterized for 100 mV input step with 10 mV overdrive on the inverting input, the non-inverting input set to the reference.
3. Comparator consumption only. Internal reference voltage (necessary for comparator operation) is not included.

9.3.13 12-bit DAC characteristics

In the following table, data are guaranteed by design, not tested in production.

Table 49. DAC characteristics

Symbol	Parameter	Conditions	Min.	Typ.	Max.	Unit
V_{DDA}	Analog supply voltage		1.8		3.6	V
V_{REF+}	Reference supply voltage		1.8		V_{DDA}	
I_{VREF}	Current consumption on V_{REF+} supply	$V_{REF+} = 3.3$ V, no load, middle code (0x800)		130	220	μ A
		$V_{REF+} = 3.3$ V, no load, worst code (0x000)		220	350	
I_{VDDA}	Current consumption on V_{DDA} supply	$V_{DDA} = 3.3$ V, no load, middle code (0x800)		210	320	
		$V_{DDA} = 3.3$ V, no load, worst code (0x000)		320	520	
T_A	Temperature range		-40		125	$^{\circ}$ C
$R_L^{(1)(2)}$	Resistive load	DACOUT buffer ON	5			k Ω
R_O	Output impedance	DACOUT buffer OFF		8	10	k Ω
$C_L^{(3)}$	Capacitive load				50	pF
DAC_OUT ₍₄₎	DAC_OUT voltage	DACOUT buffer ON	0.2		$V_{DDA} - 0.2$	V
		DACOUT buffer OFF	0		$V_{REF+} - 1$ LSB	V
$t_{settling}$	Settling time (full scale: for a 12-bit input code transition between the lowest and the highest input codes when DAC_OUT reaches the final value ± 1 LSB)	$R_L \geq 5$ k Ω , $C_L \leq 50$ pF		7	12	μ s
Update rate	Max frequency for a correct DAC_OUT (@95%) change when small variation of the input code (from code i to i+1LSB).	$R_L \geq 5$ k Ω , $C_L \leq 50$ pF			1	Msp/s
t_{WAKEUP}	Wakeup time from OFF state. Input code between lowest and highest possible codes.	$R_L \geq 5$ k Ω , $C_L \leq 50$ pF		9	15	μ s
PSRR+	Power supply rejection ratio (to V_{DDA}) (static DC measurement)	$R_L \geq 5$ k Ω , $C_L \leq 50$ pF		-60	-35	dB

1. Resistive load between DACOUT and GNDA
2. Output on PF0 or PF1
3. Capacitive load at DACOUT pin
4. It gives the output excursion of the DAC

In the following table, data based on characterization results, not tested in production.

Table 50. DAC accuracy

Symbol	Parameter	Conditions	Typ.	Max.	Unit
DNL	Differential non linearity ⁽¹⁾	$R_L \geq 5 \text{ k}\Omega$, $C_L \leq 50 \text{ pF}$ DACOUT buffer ON ⁽²⁾	1.5	3	12-bit LSB
		No load DACOUT buffer OFF	1.5	3	
INL	Integral non linearity ⁽³⁾	$R_L \geq 5 \text{ k}\Omega$, $C_L \leq 50 \text{ pF}$ DACOUT buffer ON ⁽²⁾	2	4	
		No load DACOUT buffer OFF	2	4	
Offset	Offset error ⁽⁴⁾	$R_L \geq 5 \text{ k}\Omega$, $C_L \leq 50 \text{ pF}$ DACOUT buffer ON ⁽²⁾	± 10	± 25	
		No load DACOUT buffer OFF	± 5	± 8	
Offset1	Offset error at Code 1 ⁽⁵⁾	DACOUT buffer OFF	± 1.5	± 5	
Gain error	Gain error ⁽⁶⁾	$R_L \geq 5 \text{ k}\Omega$, $C_L \leq 50 \text{ pF}$ DACOUT buffer ON ⁽²⁾	+0.1/-0.2	+0.2/-0.5	%
		No load DACOUT buffer OFF	+0/-0.2	+0/-0.4	
TUE	Total unadjusted error	$R_L \geq 5 \text{ k}\Omega$, $C_L \leq 50 \text{ pF}$ DACOUT buffer ON ⁽²⁾	12	30	12-bit LSB
		No load -DACOUT buffer OFF	8	12	

1. Difference between two consecutive codes - 1 LSB.
2. In 48-pin package devices the DAC2 output buffer must be kept off and no load must be applied on the DAC_OUT2 output.
3. Difference between measured value at Code i and the value at Code i on a line drawn between Code 0 and last Code 1023.
4. Difference between the value measured at Code (0x800) and the ideal value = $V_{REF}/2$.
5. Difference between the value measured at Code (0x001) and the ideal value.
6. Difference between the ideal slope of the transfer function and the measured slope computed from Code 0x000 and 0xFFFF when buffer is ON, and from Code giving 0.2 V and ($V_{DDA} - 0.2$) V when buffer is OFF.

In the following table, data are guaranteed by design, not tested in production.

Table 51. DAC output on PB4-PB5-PB6⁽¹⁾

Symbol	Parameter	Conditions	Max	Unit
R_{int}	Internal resistance between DAC output and PB4-PB5-PB6 output	$2.7 \text{ V} < V_{DD} < 3.6 \text{ V}$	1.4	k Ω
		$2.4 \text{ V} < V_{DD} < 3.6 \text{ V}$	1.6	
		$2.0 \text{ V} < V_{DD} < 3.6 \text{ V}$	3.2	
		$1.8 \text{ V} < V_{DD} < 3.6 \text{ V}$	8.2	

1. 32 or 28-pin packages only. The DAC channel can be routed either on PB4, PB5 or PB6 using the routing interface I/O switch registers.

9.3.14 12-bit ADC1 characteristics

In the following table, data are guaranteed by design, not tested in production.

Table 52. ADC1 characteristics

Symbol	Parameter	Conditions	Min.	Typ.	Max.	Unit
V_{DDA}	Analog supply voltage		1.8		3.6	V
V_{REF+}	Reference supply voltage	$2.4\text{ V} \leq V_{DDA} \leq 3.6\text{ V}$	2.4		V_{DDA}	V
		$1.8\text{ V} \leq V_{DDA} \leq 2.4\text{ V}$	V_{DDA}			V
V_{REF-}	Lower reference voltage		V_{SSA}			V
I_{VDDA}	Current on the V_{DDA} input pin			1000	1450	μA
I_{VREF+}	Current on the V_{REF+} input pin			400	700 (peak) ⁽¹⁾	μA
					450 (average) ⁽¹⁾	μA
V_{AIN}	Conversion voltage range		0 ⁽²⁾		V_{REF+}	
T_A	Temperature range		-40		125	$^{\circ}\text{C}$
R_{AIN}	External resistance on V_{AIN}	on PF0/1/2/3 fast channels			50 ⁽³⁾	$\text{k}\Omega$
		on all other channels				
C_{ADC}	Internal sample and hold capacitor	on PF0/1/2/3 fast channels		16		pF
		on all other channels				
f_{ADC}	ADC sampling clock frequency	$2.4\text{ V} \leq V_{DDA} \leq 3.6\text{ V}$ without zooming	0.320		16	MHz
		$1.8\text{ V} \leq V_{DDA} \leq 2.4\text{ V}$ with zooming	0.320		8	MHz
f_{CONV}	12-bit conversion rate	V_{AIN} on PF0/1/2/3 fast channels			1 ⁽³⁾⁽⁴⁾	MHz
		V_{AIN} on all other channels			760 ⁽³⁾⁽⁴⁾	kHz
f_{TRIG}	External trigger frequency				t_{conv}	$1/f_{ADC}$
t_{LAT}	External trigger latency				3.5	$1/f_{SYSCLK}$

Table 52. ADC1 characteristics (continued)

Symbol	Parameter	Conditions	Min.	Typ.	Max.	Unit
t_s	Sampling time	V_{AIN} PF0/1/2/3 fast channels $V_{DDA} < 2.4$ V	0.43 ⁽³⁾⁽⁴⁾			μ s
		V_{AIN} PF0/1/2/3 fast channels 2.4 V $\leq V_{DDA} \leq 3.6$ V	0.22 ⁽³⁾⁽⁴⁾			μ s
		V_{AIN} on slow channels $V_{DDA} < 2.4$ V	0.86 ⁽³⁾⁽⁴⁾			μ s
		V_{AIN} on slow channels 2.4 V $\leq V_{DDA} \leq 3.6$ V	0.41 ⁽³⁾⁽⁴⁾			μ s
t_{conv}	12-bit conversion time		12 + t_s			1/ f_{ADC}
		16 MHz	1 ⁽³⁾			μ s
t_{WKUP}	Wakeup time from OFF state				3	μ s
$t_{IDLE}^{(5)}$	Time before a new conversion				∞	s
$t_{VREFINT}$	Internal reference voltage startup time				refer to Table 45	ms

- The current consumption through V_{REF} is composed of two parameters:
 - one constant (max 300 μ A)
 - one variable (max 400 μ A), only during sampling time + 2 first conversion pulses.
 So, peak consumption is 300+400 = 700 μ A and average consumption is 300 + [(4 sampling + 2) / 16] x 400 = 450 μ A at 1MSPS
- V_{REF-} must be tied to ground.
- Minimum sampling and conversion time is reached for maximum $R_{AIN} = 0.5$ k Ω .
- Value obtained for continuous conversion on fast channel.
- The time between 2 conversions, or between ADC ON and the first conversion must be lower than t_{IDLE} .

In the following three tables, data are guaranteed by characterization result, not tested in production.

Table 53. ADC1 accuracy with $V_{DDA} = 3.3\text{ V to }2.5\text{ V}$

Symbol	Parameter	Conditions	Typ.	Max.	Unit
DNL	Differential non linearity	$f_{ADC} = 16\text{ MHz}$	1	1.6	LSB
		$f_{ADC} = 8\text{ MHz}$	1	1.6	
		$f_{ADC} = 4\text{ MHz}$	1	1.5	
INL	Integral non linearity	$f_{ADC} = 16\text{ MHz}$	1.2	2	
		$f_{ADC} = 8\text{ MHz}$	1.2	1.8	
		$f_{ADC} = 4\text{ MHz}$	1.2	1.7	
TUE	Total unadjusted error	$f_{ADC} = 16\text{ MHz}$	2.2	3.0	
		$f_{ADC} = 8\text{ MHz}$	1.8	2.5	
		$f_{ADC} = 4\text{ MHz}$	1.8	2.3	
Offset	Offset error	$f_{ADC} = 16\text{ MHz}$	1.5	2	LSB
		$f_{ADC} = 8\text{ MHz}$	1	1.5	
		$f_{ADC} = 4\text{ MHz}$	0.7	1.2	
Gain	Gain error	$f_{ADC} = 16\text{ MHz}$	1	1.5	
		$f_{ADC} = 8\text{ MHz}$			
		$f_{ADC} = 4\text{ MHz}$			

Table 54. ADC1 accuracy with $V_{DDA} = 2.4\text{ V to }3.6\text{ V}$

Symbol	Parameter	Typ.	Max.	Unit
DNL	Differential non linearity	1	2	LSB
INL	Integral non linearity	1.7	3	LSB
TUE	Total unadjusted error	2	4	LSB
Offset	Offset error	1	2	LSB
Gain	Gain error	1.5	3	LSB

Table 55. ADC1 accuracy with $V_{DDA} = V_{REF}^+ = 1.8\text{ V to }2.4\text{ V}$

Symbol	Parameter	Typ.	Max.	Unit
DNL	Differential non linearity	1	2	LSB
INL	Integral non linearity	2	3	LSB
TUE	Total unadjusted error	3	5	LSB
Offset	Offset error	2	3	LSB
Gain	Gain error	2	3	LSB

Figure 38. ADC1 accuracy characteristics

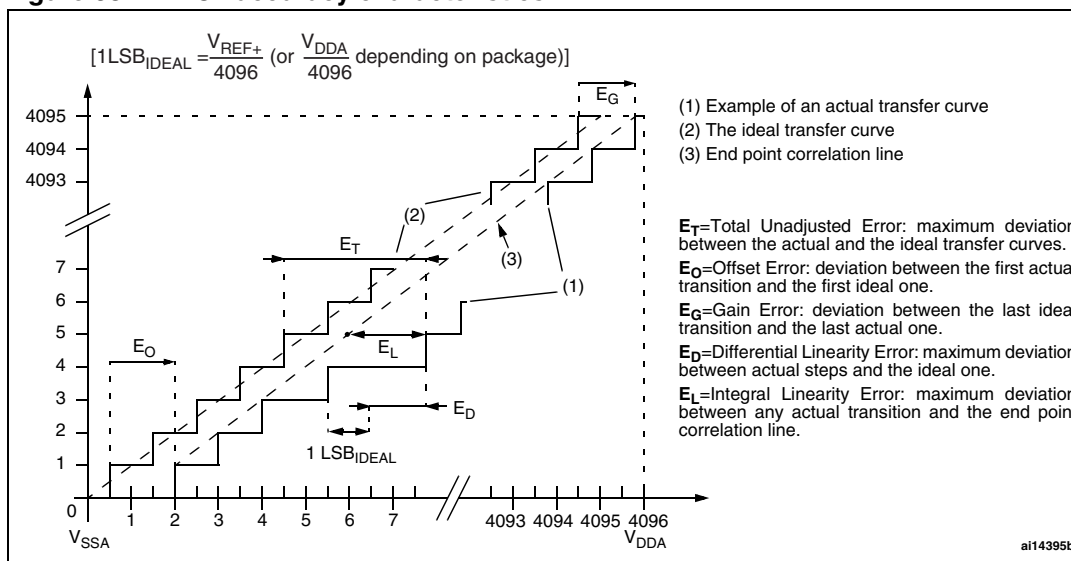
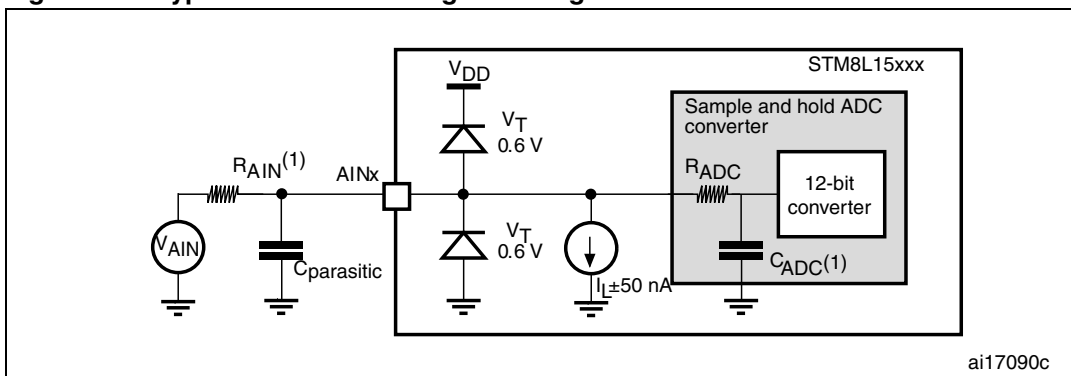

Figure 39. Typical connection diagram using the ADC



1. Refer to [Table 52](#) for the values of R_{AIN} and C_{ADC} .
2. $C_{parasitic}$ represents the capacitance of the PCB (dependent on soldering and PCB layout quality) plus the pad capacitance (roughly 7 pF). A high $C_{parasitic}$ value will downgrade conversion accuracy. To remedy this, f_{ADC} should be reduced.

General PCB design guidelines

Power supply decoupling should be performed as shown in [Figure 40](#) or [Figure 41](#), depending on whether V_{REF+} is connected to V_{DDA} or not. Good quality ceramic 10 nF capacitors should be used. They should be placed as close as possible to the chip.

Figure 40. Power supply and reference decoupling (V_{REF+} not connected to V_{DDA})

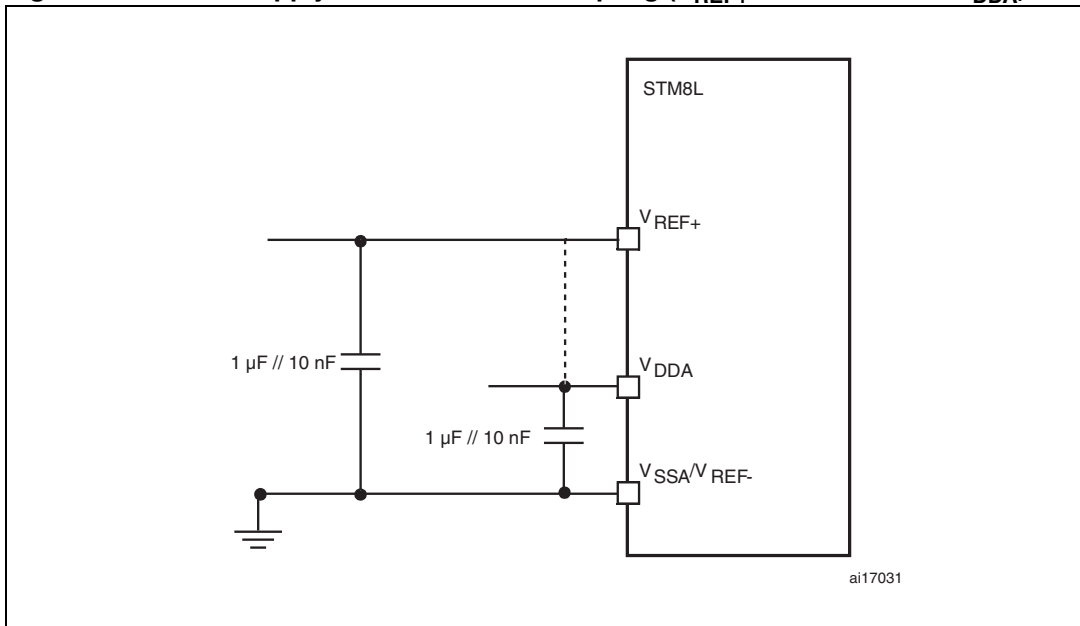
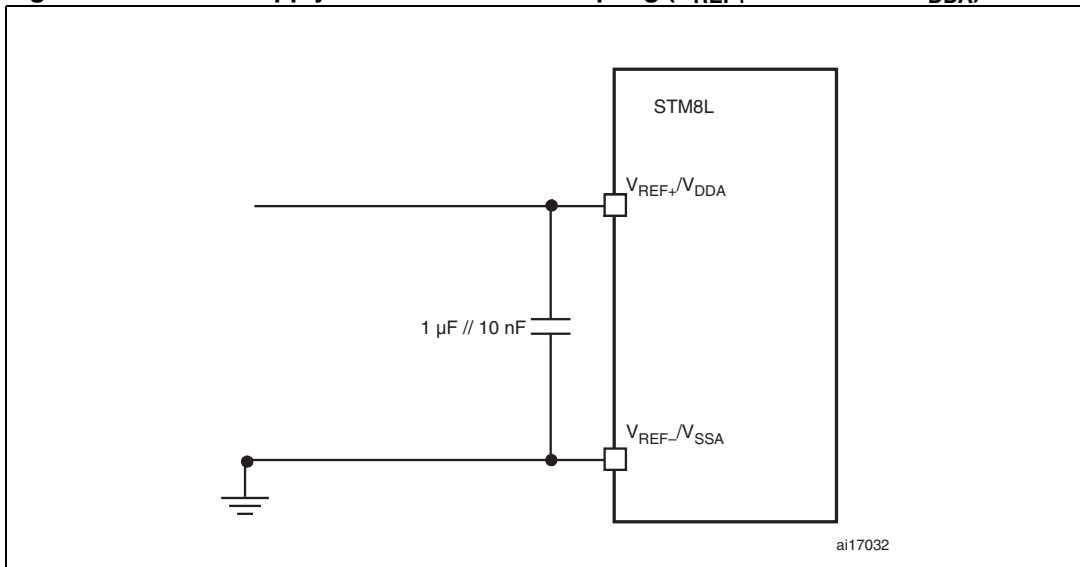

Figure 41. Power supply and reference decoupling (V_{REF+} connected to V_{DDA})



9.3.15 EMC characteristics

Susceptibility tests are performed on a sample basis during product characterization.

Functional EMS (electromagnetic susceptibility)

Based on a simple running application on the product (toggling 2 LEDs through I/O ports), the product is stressed by two electromagnetic events until a failure occurs (indicated by the LEDs).

- **ESD:** Electrostatic discharge (positive and negative) is applied on all pins of the device until a functional disturbance occurs. This test conforms with the IEC 61000 standard.
- **FTB:** A burst of fast transient voltage (positive and negative) is applied to V_{DD} and V_{SS} through a 100 pF capacitor, until a functional disturbance occurs. This test conforms with the IEC 61000 standard.

A device reset allows normal operations to be resumed. The test results are given in the table below based on the EMS levels and classes defined in application note AN1709.

Designing hardened software to avoid noise problems

EMC characterization and optimization are performed at component level with a typical application environment and simplified MCU software. It should be noted that good EMC performance is highly dependent on the user application and the software in particular.

Therefore it is recommended that the user applies EMC software optimization and prequalification tests in relation with the EMC level requested for his application.

Prequalification trials:

Most of the common failures (unexpected reset and program counter corruption) can be reproduced by manually forcing a low state on the NRST pin or the Oscillator pins for 1 second.

To complete these trials, ESD stress can be applied directly on the device, over the range of specification values. When unexpected behavior is detected, the software can be hardened to prevent unrecoverable errors occurring (see application note AN1015).

Table 56. EMS data

Symbol	Parameter	Conditions	Level/Class	
V_{FESD}	Voltage limits to be applied on any I/O pin to induce a functional disturbance	$V_{DD} = 3.3\text{ V}$, $T_A = +25\text{ °C}$, $f_{CPU} = 16\text{ MHz}$, conforms to IEC 61000	2B	
V_{EFTB}	Fast transient voltage burst limits to be applied through 100 pF on V_{DD} and V_{SS} pins to induce a functional disturbance	$V_{DD} = 3.3\text{ V}$, $T_A = +25\text{ °C}$, $f_{CPU} = 16\text{ MHz}$, conforms to IEC 61000	Using HSI	4A
			Using HSE	2B

Electromagnetic interference (EMI)

Based on a simple application running on the product (toggling 2 LEDs through the I/O ports), the product is monitored in terms of emission. This emission test is in line with the norm IEC61967-2 which specifies the board and the loading of each pin.

Table 57. EMI data (1)

Symbol	Parameter	Conditions	Monitored frequency band	Max vs.	Unit
				16 MHz	
S _{EMI}	Peak level	V _{DD} = 3.6 V, T _A = +25 °C, LQFP80 conforming to IEC61967-2	0.1 MHz to 30 MHz	10	dB μ V
			30 MHz to 130 MHz	4	
			130 MHz to 1 GHz	1	
			SAE EMI Level	1.5	-

1. Not tested in production.

Absolute maximum ratings (electrical sensitivity)

Based on two different tests (ESD and LU) using specific measurement methods, the product is stressed in order to determine its performance in terms of electrical sensitivity. For more details, refer to the application note AN1181.

Electrostatic discharge (ESD)

Electrostatic discharges (a positive then a negative pulse separated by 1 second) are applied to the pins of each sample according to each pin combination. The sample size depends on the number of supply pins in the device (3 parts*(n+1) supply pin). Two models can be simulated: human body model and charge device model. This test conforms to the JESD22-A114A/A115A standard.

Table 58. ESD absolute maximum ratings

Symbol	Ratings	Conditions	Maximum value (1)	Unit
V _{ESD(HBM)}	Electrostatic discharge voltage (human body model)	T _A = +25 °C	2000	V
V _{ESD(CDM)}	Electrostatic discharge voltage (charge device model)		750	

1. Data based on characterization results, not tested in production.

Static latch-up

- **LU:** 3 complementary static tests are required on 10 parts to assess the latch-up performance. A supply overvoltage (applied to each power supply pin) and a current injection (applied to each input, output and configurable I/O pin) are performed on each sample. This test conforms to the EIA/JESD 78 IC latch-up standard. For more details, refer to the application note AN1181.

Table 59. Electrical sensitivities

Symbol	Parameter	Class
LU	Static latch-up class	II

9.4 Thermal characteristics

The maximum chip junction temperature (T_{Jmax}) must never exceed the values given in [Table 17: General operating conditions on page 64](#).

The maximum chip-junction temperature, T_{Jmax} , in degree Celsius, may be calculated using the following equation:

$$T_{Jmax} = T_{Amax} + (P_{Dmax} \times \Theta_{JA})$$

Where:

- T_{Amax} is the maximum ambient temperature in °C
- Θ_{JA} is the package junction-to-ambient thermal resistance in °C/W
- P_{Dmax} is the sum of P_{INTmax} and $P_{I/Omax}$ ($P_{Dmax} = P_{INTmax} + P_{I/Omax}$)
- P_{INTmax} is the product of I_{DD} and V_{DD} , expressed in Watts. This is the maximum chip internal power.
- $P_{I/Omax}$ represents the maximum power dissipation on output pins

Where:

$$P_{I/Omax} = \Sigma (V_{OL} * I_{OL}) + \Sigma ((V_{DD} - V_{OH}) * I_{OH}),$$

taking into account the actual V_{OL}/I_{OL} and V_{OH}/I_{OH} of the I/Os at low and high level in the application.

Table 60. Thermal characteristics⁽¹⁾

Symbol	Parameter	Value	Unit
Θ_{JA}	Thermal resistance junction-ambient LQFP 48- 7 x 7 mm	65	°C/W
Θ_{JA}	Thermal resistance junction-ambient UFQFPN 48- 7 x 7mm	32	°C/W
Θ_{JA}	Thermal resistance junction-ambient LQFP 64- 10 x 10 mm	48	°C/W
Θ_{JA}	Thermal resistance junction-ambient LQFP 80- 14 x 14 mm	38	°C/W

1. Thermal resistances are based on JEDEC JESD51-2 with 4-layer PCB in a natural convection environment.

10 Package characteristics

10.1 Package mechanical data

In order to meet environmental requirements, ST offers these devices in different grades of ECOPACK[®] packages, depending on their level of environmental compliance. ECOPACK[®] specifications, grade definitions and product status are available at: www.st.com. ECOPACK[®] is an ST trademark.

Figure 42. 80-pin low profile quad flat package (14 x 14 mm)

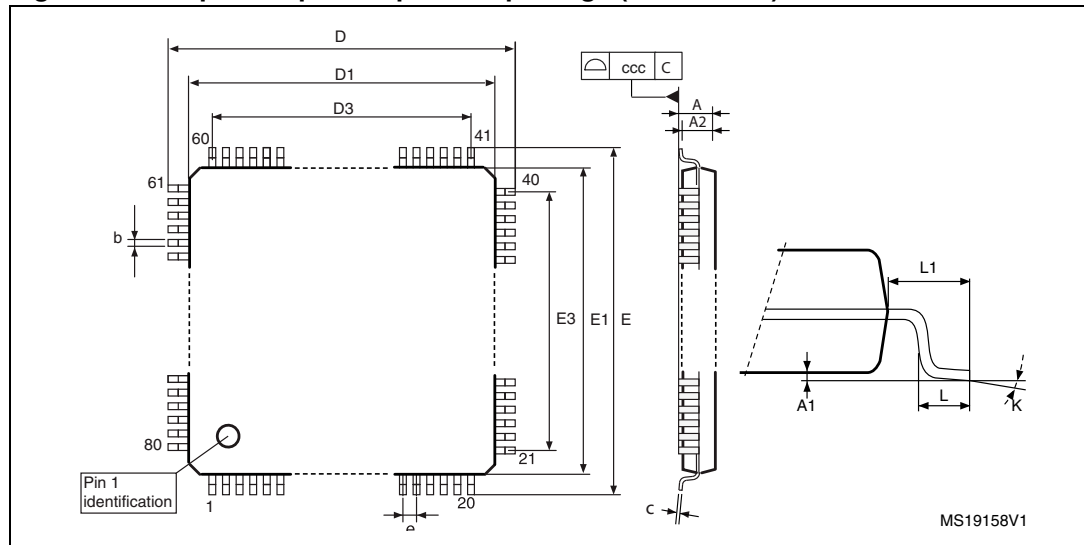
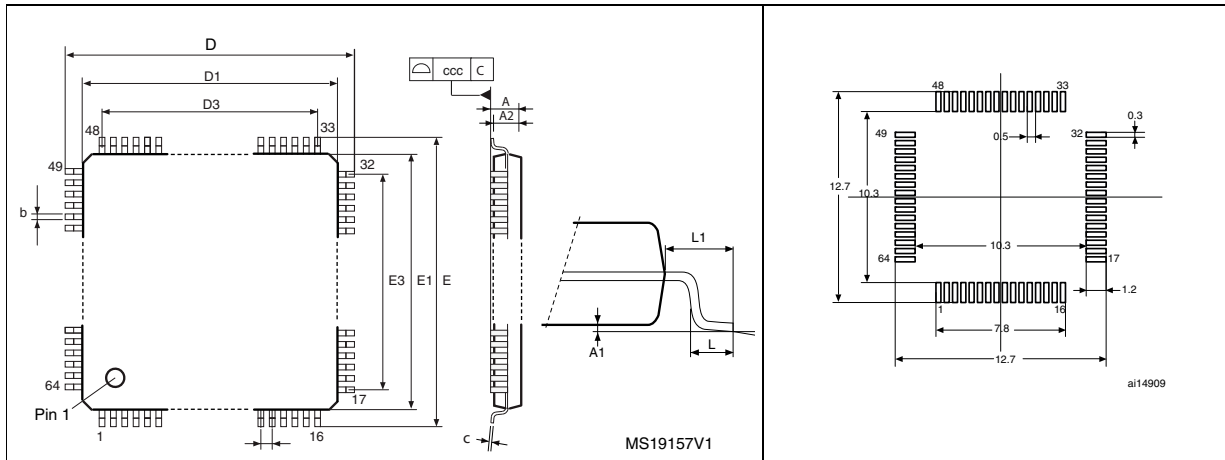

Table 61. 80-pin low profile quad flat package mechanical data

Symbol	mm			inches ⁽¹⁾		
	Min	Typ	Max	Min	Typ	Max
A	-	-	1.600	-	-	0.0630
A1	0.050	-	0.150	0.0020	-	0.0059
A2	1.350	1.400	1.450	0.0531	0.0551	0.0571
b	0.220	0.320	0.380	0.0087	0.0126	0.0150
c	0.090	-	0.200	0.0035	-	0.0079
D	15.800	16.000	16.200	0.6220	0.6299	0.6378
D1	13.800	14.000	14.200	0.5433	0.5512	0.5591
D3	-	12.350	-	-	0.4862	-
E	15.800	16.000	16.200	0.6220	0.6299	0.6378
E1	13.800	14.000	14.200	0.5433	0.5512	0.5591
E3	-	12.350	-	-	0.4862	-
e	-	0.650	-	-	0.0256	-
L	0.450	0.600	0.750	0.0177	0.0236	0.0295
L1	-	1.000	-	-	0.0394	-
k	0.0°	3.5°	7.0°	0.0°	3.5°	7.0°
ccc	-	-	0.100	-	-	0.0039

1. Values in inches are converted from mm and rounded to four decimal places.

Figure 43. LQFP64 – 10 x 10 mm, 64 pin low-profile quad flat package outline⁽¹⁾ **Figure 44. Recommended footprint⁽¹⁾⁽²⁾**



1. Drawing is not to scale.
2. Dimensions are in millimeters.

Table 62. LQFP64 – 10 x 10 mm, 64-pin low-profile quad flat package mechanical data

Symbol	millimeters			inches ⁽¹⁾		
	Min	Typ	Max	Min	Typ	Max
A			1.60			0.0630
A1	0.05		0.15	0.0020		0.0059
A2	1.35	1.40	1.45	0.0531	0.0551	0.0571
b	0.17	0.22	0.27	0.0067	0.0087	0.0106
c	0.09		0.20	0.0035		0.0079
D		12.00			0.4724	
D1		10.00			0.3937	
E		12.00			0.4724	
E1		10.00			0.3937	
e		0.50			0.0197	
θ	0°	3.5°	7°	0°	3.5°	7°
L	0.45	0.60	0.75	0.0177	0.0236	0.0295
L1		1.00			0.0394	
Number of pins						
N	64					

1. Values in inches are converted from mm and rounded to 4 decimal digits.

11 Ordering information scheme

Table 63. Ordering information scheme

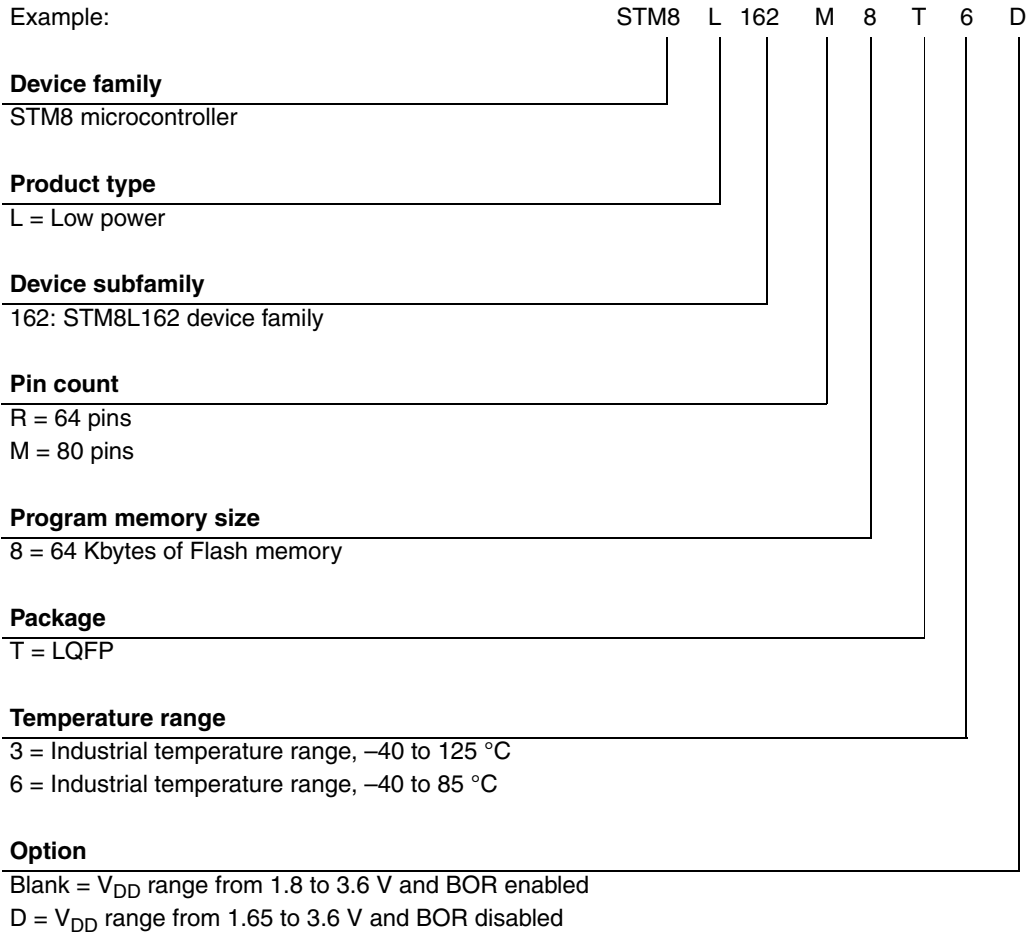

For a list of available options (e.g. memory size, package) and orderable part numbers or for further information on any aspect of this device, please go to www.st.com or contact the ST Sales Office nearest to you.

12 Revision history

Table 64. Document revision history

Date	Revision	Changes
14-Sep-2010	1	Initial release.
22-Mar-2011	2	<p><i>Table 4: STM8L162x pin description</i>: updated “standard port” changed to “high sink port”.</p> <p><i>Figure 5: Memory map</i>: updated the address range of the AES registers.</p> <p><i>Table 8: General hardware register map</i>: updated the address range of the AES registers.</p> <p><i>Table 14: Voltage characteristics</i>: updated</p> <p><i>Table 15: Current characteristics</i>: updated</p> <p><i>Table 34: RAM and hardware registers</i>: updated VRM data min. retention.</p> <p>Added <i>Table 9.3.6: I/O current injection characteristics</i>.</p> <p><i>Table 37: I/O static characteristics</i>: updated</p> <p><i>Table 44: LCD characteristics</i>: updated</p>
10-Jul-2012	3	<p>Modified LCD pin names in <i>Table 4: STM8L162x pin description</i></p> <p>Corrected LCD corresponding register numbers in <i>Table 8: General hardware register map</i></p> <p>Corrected the user manual name in <i>Section 7: Option bytes</i></p> <p>Replaced comparator tables with STM32 tables in <i>Section 9.3.12: Comparator characteristics</i></p> <p>Added “The ram content is preserved” in <i>Section 3.1: Low power modes</i></p> <p>Modified capacitive sensing channel bullet in <i>Features</i></p> <p>Modified last sentence in <i>Section 3.12: System configuration controller and routing interface</i></p> <p>Added <i>Section 3.13: Touch sensing</i></p> <p>Replaced “Vref+ - 0.2” with “VDDA - 0.2” for DAC_OUT in <i>Table 49: DAC characteristics</i></p>

Please Read Carefully:

Information in this document is provided solely in connection with ST products. STMicroelectronics NV and its subsidiaries ("ST") reserve the right to make changes, corrections, modifications or improvements, to this document, and the products and services described herein at any time, without notice.

All ST products are sold pursuant to ST's terms and conditions of sale.

Purchasers are solely responsible for the choice, selection and use of the ST products and services described herein, and ST assumes no liability whatsoever relating to the choice, selection or use of the ST products and services described herein.

No license, express or implied, by estoppel or otherwise, to any intellectual property rights is granted under this document. If any part of this document refers to any third party products or services it shall not be deemed a license grant by ST for the use of such third party products or services, or any intellectual property contained therein or considered as a warranty covering the use in any manner whatsoever of such third party products or services or any intellectual property contained therein.

UNLESS OTHERWISE SET FORTH IN ST'S TERMS AND CONDITIONS OF SALE ST DISCLAIMS ANY EXPRESS OR IMPLIED WARRANTY WITH RESPECT TO THE USE AND/OR SALE OF ST PRODUCTS INCLUDING WITHOUT LIMITATION IMPLIED WARRANTIES OF MERCHANTABILITY, FITNESS FOR A PARTICULAR PURPOSE (AND THEIR EQUIVALENTS UNDER THE LAWS OF ANY JURISDICTION), OR INFRINGEMENT OF ANY PATENT, COPYRIGHT OR OTHER INTELLECTUAL PROPERTY RIGHT.

UNLESS EXPRESSLY APPROVED IN WRITING BY TWO AUTHORIZED ST REPRESENTATIVES, ST PRODUCTS ARE NOT RECOMMENDED, AUTHORIZED OR WARRANTED FOR USE IN MILITARY, AIR CRAFT, SPACE, LIFE SAVING, OR LIFE SUSTAINING APPLICATIONS, NOR IN PRODUCTS OR SYSTEMS WHERE FAILURE OR MALFUNCTION MAY RESULT IN PERSONAL INJURY, DEATH, OR SEVERE PROPERTY OR ENVIRONMENTAL DAMAGE. ST PRODUCTS WHICH ARE NOT SPECIFIED AS "AUTOMOTIVE GRADE" MAY ONLY BE USED IN AUTOMOTIVE APPLICATIONS AT USER'S OWN RISK.

Resale of ST products with provisions different from the statements and/or technical features set forth in this document shall immediately void any warranty granted by ST for the ST product or service described herein and shall not create or extend in any manner whatsoever, any liability of ST.

ST and the ST logo are trademarks or registered trademarks of ST in various countries.

Information in this document supersedes and replaces all information previously supplied.

The ST logo is a registered trademark of STMicroelectronics. All other names are the property of their respective owners.

© 2012 STMicroelectronics - All rights reserved

STMicroelectronics group of companies

Australia - Belgium - Brazil - Canada - China - Czech Republic - Finland - France - Germany - Hong Kong - India - Israel - Italy - Japan - Malaysia - Malta - Morocco - Philippines - Singapore - Spain - Sweden - Switzerland - United Kingdom - United States of America

www.st.com