

## Full-speed USB MCU with smartcard interface

### Features

- Clock, reset and supply management
  - Low voltage reset
  - Halt power saving mode
  - PLL for generating 48 MHz USB clock using a 4 MHz crystal
- USB (Universal Serial Bus) host interface
  - USB 2.0 compliant
  - CCID v1.0
  - Full speed, hubless
  - Bus-powered, low consumption
- ISO7816-3 UART Interface
  - 4 MHz clock generation
  - Synchronous/asynchronous protocols (T=0, T=1)
  - Automatic retry on parity error
  - Programmable baud rate from 372 to 11.625 clock pulses (D=32/F=372)
  - Card insertion/removal detection
- Smartcard power supply ( $V_{CRDVCC}$ )
  - Fixed supply voltage: 1.8 V or 3 V

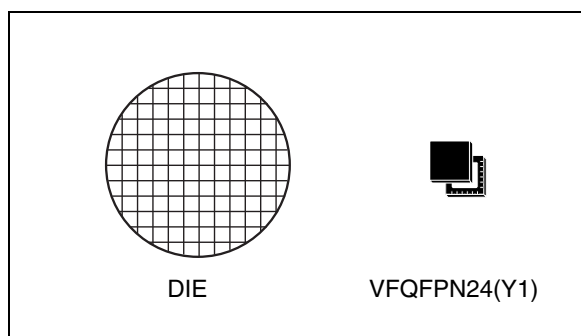

- Development tools
  - Full hardware/software development package.
  - Fully compatible with Flash ST7FSCR family for development purposes
- ECOPACK® package

### Description

ST7LCRE4U1 and ST7LCRDIE6 are 8-bit microcontrollers dedicated to smartcard reading applications. They have been developed to be the core of smartcard readers communicating through USB link. Optimized for mass-market applications, it offers a single integrated circuit solution with very few external components.

**Table 1. Device summary**

Features	Order codes	
	ST7LCRE4U1	ST7LCRDIE6
Program memory	16 Kbyte of ROM	
User RAM + USB data buffer	512 + 256 bytes	
Peripherals	USB full-speed (7 Ep), TBU, watchdog timer, ISO7816-3 interface	
Operating Supply	4.0 to 5.5 V	
Package	VFQFPN24	Die format (Refer to Die Specifications)
CPU Frequency	4 or 8 MHz	
Operating temperature	0°C to +70 °C	

# Contents

<b>1</b>	<b>Device overview</b> .....	<b>6</b>
<b>2</b>	<b>Pin description</b> .....	<b>8</b>
<b>3</b>	<b>ST7LCR implementation</b> .....	<b>11</b>
3.1	Functionality .....	11
3.2	Smartcard interface features .....	11
<b>4</b>	<b>Electrical characteristics</b> .....	<b>12</b>
4.1	Absolute maximum ratings .....	12
4.2	Recommended operating conditions .....	13
4.2.1	General operating conditions .....	13
4.2.2	Current injection .....	13
4.2.3	Current consumption .....	14
4.2.4	I/O port pin characteristics .....	14
4.3	Supply and reset characteristics .....	15
4.4	Clock and timing characteristics .....	15
4.4.1	General timings .....	15
4.4.2	External clock source .....	16
4.4.3	Crystal resonator oscillators .....	17
4.5	Memory characteristics .....	18
4.6	Smartcard supply supervisor electrical characteristics .....	18
4.7	EMC characteristics .....	20
4.7.1	Functional EMS (electromagnetic susceptibility) .....	20
4.7.2	Electromagnetic interference (EMI) .....	21
4.7.3	Absolute maximum ratings (electrical sensitivity) .....	21
4.8	Communication interface characteristics .....	22
<b>5</b>	<b>Package characteristics</b> .....	<b>24</b>
5.1	Package mechanical data .....	25
5.2	Recommended reflow oven profile .....	26
<b>6</b>	<b>Device configuration and ordering information</b> .....	<b>27</b>

**7**      **Revision history** ..... **29**

## List of tables

Table 1.	Device summary . . . . .	1
Table 2.	Pin description . . . . .	8
Table 3.	Absolute maximum ratings . . . . .	12
Table 4.	Thermal characteristics . . . . .	13
Table 5.	General operating conditions . . . . .	13
Table 6.	Current injection on I/O port and control pins . . . . .	14
Table 7.	Current consumption . . . . .	14
Table 8.	I/O port pins characteristics . . . . .	14
Table 9.	Low voltage detector and supervisor (LVDs) . . . . .	15
Table 10.	General timings . . . . .	15
Table 11.	External clock source characteristics . . . . .	16
Table 12.	Crystal resonator characteristics . . . . .	17
Table 13.	Typical crystal resonator characteristics . . . . .	17
Table 14.	Recommended values for 4 MHz crystal resonator . . . . .	17
Table 15.	RAM and hardware registers characteristics . . . . .	18
Table 16.	Smartcard supply supervisor electrical characteristics . . . . .	18
Table 17.	EMS characteristics . . . . .	20
Table 18.	EMI characteristics . . . . .	21
Table 19.	Absolute maximum ratings . . . . .	21
Table 20.	Electrical sensitivities . . . . .	22
Table 21.	USB DC electrical characteristics . . . . .	22
Table 22.	USB full-speed electrical characteristics . . . . .	23
Table 23.	24-lead very thin fine pitch quad flat no-lead 5x5mm,0.65mm pitch, mechanical data. . . . .	25
Table 24.	Ordering information . . . . .	27
Table 25.	Document revision history . . . . .	29

## List of figures

Figure 1.	ST7LCR block diagram . . . . .	7
Figure 2.	24-lead VFQFPN package pinout. . . . .	8
Figure 3.	Smartcard interface reference application - VFQFPN24 pin block diagram . . . . .	10
Figure 4.	Typical application with an external clock source . . . . .	16
Figure 5.	Typical application with a crystal resonator . . . . .	18
Figure 6.	USB data signal rise and fall time. . . . .	22
Figure 7.	24-lead very thin fine pitch quad flat no-lead 5x5 mm 0.65 mm pitch, package outline . . .	25
Figure 8.	ST7LCR option list . . . . .	28

# 1 Device overview

The ST7LCRE4U1 and ST7LCDIE6 devices are members of the ST7 microcontroller family designed for USB applications. All devices are based on a common industry-standard 8-bit core, featuring an enhanced instruction set.

ST7LCRE4U1 and ST7LCDIE6 are factory-programmed ROM devices.

They operate at a 4 MHz external oscillator frequency.

Under software control, all devices can be placed in Halt mode, to reduce power consumption when the application is in idle or standby state.

The enhanced instruction set and addressing modes of the ST7 offer both power and flexibility to software developers, enabling the design of highly efficient and compact application code. In addition to standard 8-bit data management, all ST7 microcontrollers feature true bit manipulation, 8x8 unsigned multiplication and indirect addressing modes.

The devices include an ST7 Core, up to 16 Kbytes of program memory, up to 512 bytes of user RAM and the following on-chip peripherals:

- USB full speed interface with 7 endpoints, programmable in/out configuration and embedded 3.3 V voltage regulator and transceivers (no external components are needed)
- ISO7816-3 UART interface with programmable baud rate from 372 clock pulses up to 11.625 clock pulses
- Internal voltage regulator able to provide a fixed supply voltage ( $V_{CRDVCC}$ ) to smartcards. The voltage is selectable by option between 1.8 V and 3 V.
- Low voltage reset ensuring proper power-on or power-off of the device (selectable by option)
- 8-bit Timer (TBU)

Figure 1. ST7LCR block diagram

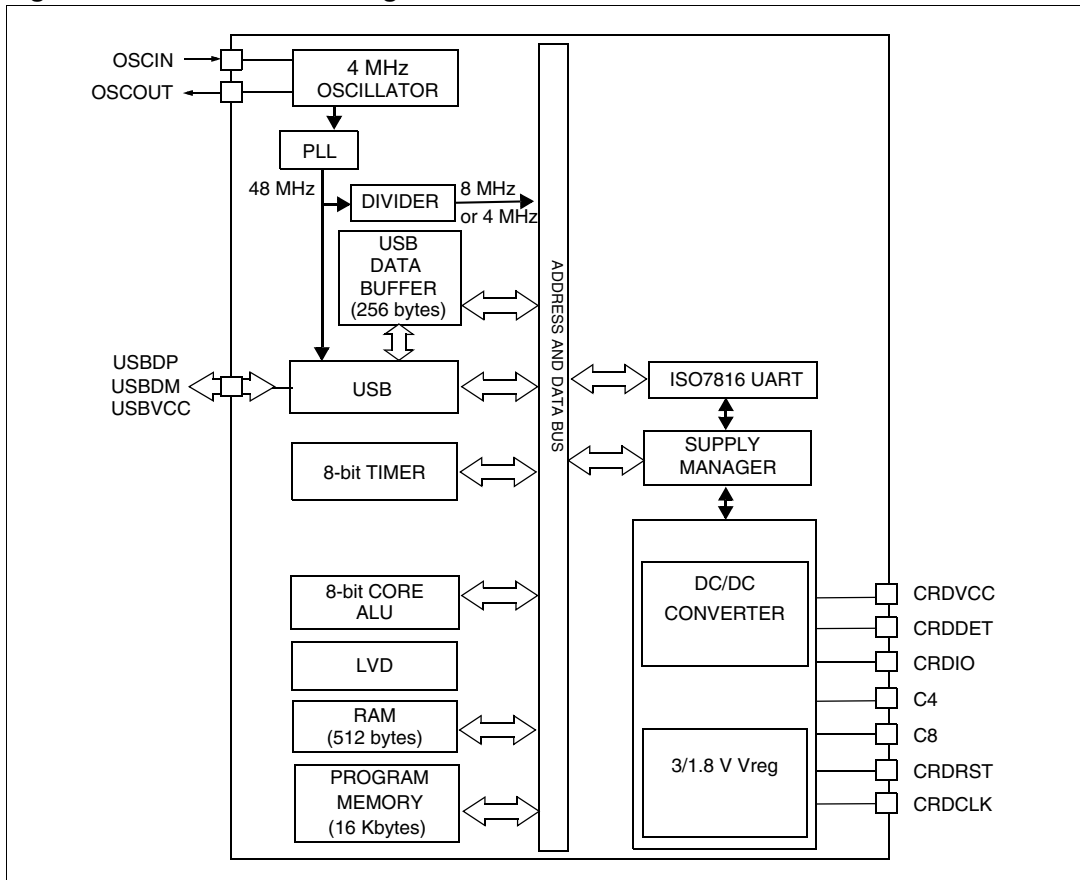

## 2 Pin description

Figure 2. 24-lead VFQFPN package pinout

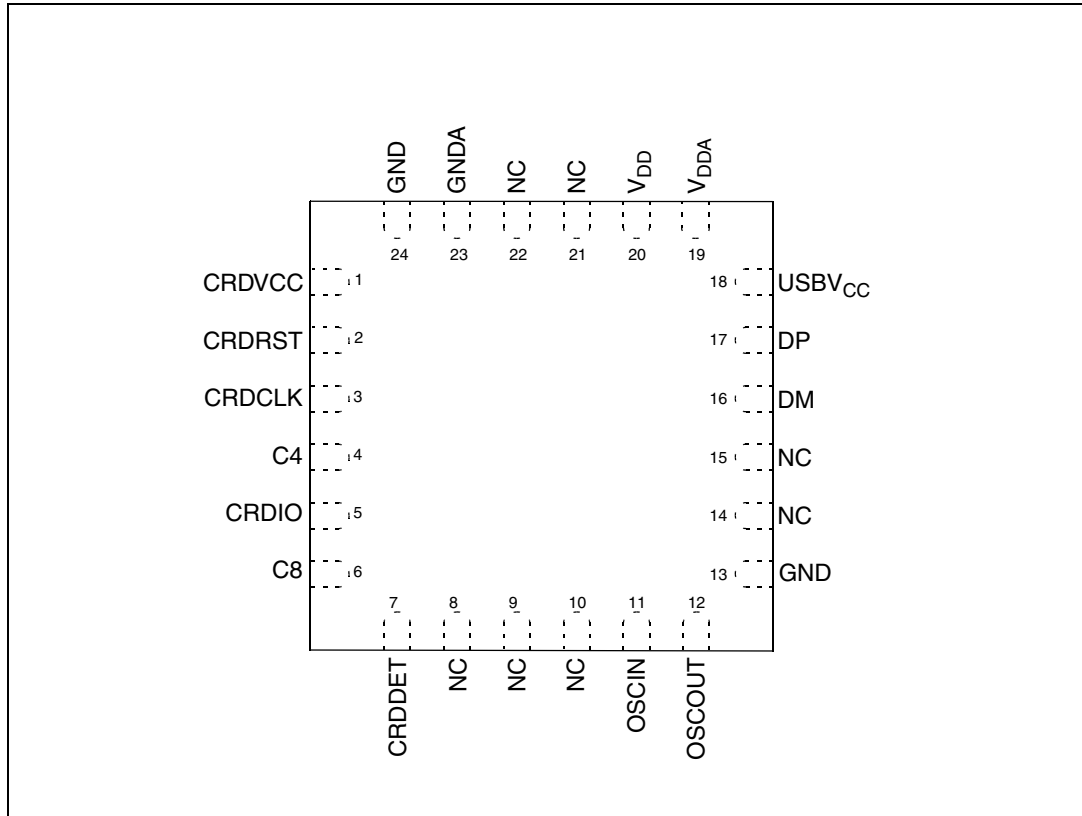

Table 2. Pin description

Pin number	Pin name	Type	Level		V <sub>CARD</sub> supplied	Port/control				Main function (after reset)	Alternate function
			Input	Output		Input	Output				
VFQFPN24						wpu	int	OD	PP		
1	CRDVCC	O		C <sub>T</sub>	X						Smartcard supply pin
2	CRDRST	O		C <sub>T</sub>	X				X		Smartcard reset
3	CRDCLK	O		C <sub>T</sub>	X				X		Smartcard clock
4	C4	O		C <sub>T</sub>	X				X		Smartcard C4
5	CRDIO	I/O		C <sub>T</sub>	X	X		X			Smartcard I/O
6	C8	O		C <sub>T</sub>	X				X		Smartcard C8
7	CRDDET	I		C <sub>T</sub>		X					Smartcard detection
8	NC										Not used <sup>(1)</sup>
9	NC										Not used <sup>(1)</sup>
10	NC										Not used <sup>(1)</sup>

**Table 2. Pin description (continued)**

Pin number	Pin name	Type	Level		V <sub>CARD</sub> supplied	Port/control				Main function (after reset)	Alternate function
			Input	Output		Input		Output			
VFQFPN24						wpu	int	OD	PP		
11	OSGIN		C <sub>T</sub>							Input/Output oscillator pins. These pins connect a 4 MHz parallel-resonant crystal, or an external source to the on-chip oscillator.	
12	OSGOUT			C <sub>T</sub>							
13	GND	S								Must be held low in normal operating mode.	
14	NC									Not used <sup>(1)</sup>	
15	NC									Not used	
16	DM	I/O	C <sub>T</sub>							USB Data Minus line	
17	DP	I/O	C <sub>T</sub>							USB Data Plus line	
18	USBVCC	O		C <sub>T</sub>						3.3 V Output for USB	
19	V <sub>DDA</sub>	S								Power supply voltage 4-5.5 V	
20	V <sub>DD</sub>	S								Power supply voltage 4-5.5 V	
21	NC									Not used	
22	NC									Not used	
23	GND <sub>A</sub>	S								Ground	
24	GND	S									

1. Pins 8,9,10, and 14 must be connected to ground.

**Legend/abbreviations**

- Type: I = input, O = output, S = supply
- In/Output level: C<sub>T</sub> = CMOS 0.3V<sub>DD</sub>/0.7V<sub>DD</sub> with input trigger
- Output level: HS = 10 mA high sink (on N-buffer only)
- Port and control configuration:
  - Input: float = floating, wpu = weak pull-up, int = interrupt, ana = analog
  - Output: OD = open drain, PP = push-pull



## 3 ST7LCR implementation

ST7LCRE4U1 and ST7LCRDIE6 offer single IC solutions and simplifies the integration of smartcard interfaces into smartcard readers.

### 3.1 Functionality

A dedicated analog block provides the power supply necessary to interface with the smartcards available on the market. The supply voltage can be selected by option between 1.8 V and 3 V (see [Section 6: Device configuration and ordering information](#)). A dedicated UART interface provides an ISO7816 communication port for connection with the smartcard connector. A full-speed USB interface port allows external connection to a host computer.

### 3.2 Smartcard interface features

The ST7LCRE4U1 and ST7LCRDIE6 include the following features:

- Compatibility with asynchronous cards
- Compatibility with T=0 and T=1 protocols
- Compatibility with EMV and PC/SC modes.
- Compliance with ISO 7816-3 and 4 and ability to supply the cards with 1.8 V or 3 V (class A, B or C cards, respectively)
- Resume/wake-up mode upon smartcard insertion/removal

The reader is able to communicate with smartcards up to the maximum baud rate allowed, namely 344 086 bps (TA1=16) for a clock frequency of 4 MHz. Because the size of the smartcard buffer is 261 bytes, care must be taken not to exceed this size during APDU exchanges when the protocol in use is T=1.

## 4 Electrical characteristics

### 4.1 Absolute maximum ratings

This product contains devices for protecting the inputs against damage due to high static voltages, however it is advisable to take normal precautions to avoid applying any voltage higher than the specified maximum rated voltages. For proper operation it is recommended that  $V_I$  and  $V_O$  be higher than  $V_{SS}$  and lower than  $V_{DD}$ . Reliability is enhanced if unused inputs are connected to an appropriate logic voltage level ( $V_{DD}$  or  $V_{SS}$ ).

#### Power considerations

The average chip-junction temperature,  $T_J$ , in Celsius can be obtained from:

$$T_J = T_A + P_D \times R_{thJA}$$

where:

$T_A$  = Ambient temperature

$R_{thJA}$  = Package thermal resistance (junction-to ambient)

$P_D = P_{INT} + P_{PORT}$

$P_{INT} = I_{DD} \times V_{DD}$  (chip internal power)

$P_{PORT}$  = Port power dissipation determined by the user

Stresses above those listed as “absolute maximum ratings” may cause permanent damage to the device. This is a stress rating only and functional operation of the device at these conditions is not implied. Exposure to maximum rating for extended periods may affect device reliability.

**Table 3. Absolute maximum ratings**

Symbol	Ratings	Value	Unit
$V_{DD} - V_{SS}$	Supply voltage	6.0	V
$V_{IN}$	Input voltage	$V_{SS} - 0.3$ to $V_{DD} + 0.3$	V
$V_{OUT}$	Output voltage	$V_{SS} - 0.3$ to $V_{DD} + 0.3$	V
ESD	ESD susceptibility	2000	V
ESDCard	ESD susceptibility for card pads	4000	V
$I_{VDD\_I}$	Total current into $V_{DD\_I}$ (source)	250	mA
$I_{VSS\_I}$	Total current out of $V_{SS\_I}$ (sink)	250	

**Warning:** Direct connection to  $V_{DD}$  or  $V_{SS}$  of the I/O pins could damage the device in case of program counter corruption (due to unwanted change of the I/O configuration). To guarantee safe conditions, this connection has to be done through a typical 10k $\Omega$  pull-up or pull-down resistor.

**Table 4. Thermal characteristics**

Symbol	Ratings	Value	Unit
$R_{thJA}$	Package thermal resistance VFQFPN24	42	°C/W
$T_{Jmax}$	Max. junction temperature	150	°C
$T_{STG}$	Storage temperature range	-65 to +150	°C
$PD_{max}$	Power dissipation VFQFPN24	600	mW

## 4.2 Recommended operating conditions

Operating conditions are given for  $T_A = 0$  to  $+70$  °C unless otherwise specified.

### 4.2.1 General operating conditions

**Table 5. General operating conditions**

Symbol	Parameter	Conditions	Min	Typ	Max	Unit
$V_{DD}$	Supply voltage		4.0		5.5	V
$f_{OSC}$	External clock source				16	MHz
$T_A$	Ambient temperature range		0		70	°C

### 4.2.2 Current injection

#### Positive injection

The positive injection current,  $I_{INJ+}$ , is **applied** through protection diodes insulated from the substrate of the die.

#### Negative injection

The negative injection current,  $I_{INJ-}$ , is **applied** through protection diodes NOT INSULATED from the substrate of the die. The drawback is a small leakage of few  $\mu A$  induced inside the die when a negative injection is performed. This leakage is tolerated by the digital structure. The effect depends on the pin which is submitted to the injection. Of course, external digital signals applied to the component must have a maximum impedance close to 50 k $\Omega$ .

Pure digital pins can tolerate a negative current injection of 1.6 mA. In addition, the best choice is to inject the current as far as possible from the analog input pins.

*Note:* When several inputs are submitted to a current injection, the maximum injection current is the sum of the positive (respectively negative) currents (instantaneous values).

Refer to [Table 6](#) for the values of  $I_{INJ-}$  and  $I_{INJ+}$ .

**Table 6. Current injection on I/O port and control pins**

Symbol	Parameter	Conditions	Min	Typ	Max	Unit	
$I_{INJ+}$	Total positive injected current <sup>(1)</sup>	$V_{EXTERNAL} > V_{DD}$ (standard I/Os)			20	mA	
		$V_{EXTERNAL} > V_{CRDVCC}$ (smartcard I/Os)			20	mA	
$I_{INJ-}$	Total negative injected current	$V_{EXTERNAL} < V_{SS}$	Digital pins			20	mA
			Analog pins			20	mA

1. For smartcard I/Os,  $V_{CRDVCC}$  has to be considered.

### 4.2.3 Current consumption

[Table 7](#) are measured at  $T_A=0$  to  $+70^\circ\text{C}$ , and  $V_{DD}-V_{SS}=5.5$  V unless otherwise specified.

**Table 7. Current consumption<sup>(1)</sup>**

Symbol	Parameter	Conditions	Min	Typ	Max	Unit
$I_{DD}$	Supply current in Run mode <sup>(2)</sup>	$f_{OSC} = 4$ MHz		10	15	mA
	Supply current in suspend mode	External $I_{LOAD} = 0$ mA (USB transceiver enabled)			500	$\mu\text{A}$
	Supply current in Halt mode	External $I_{LOAD} = 0$ mA (USB transceiver disabled)		50	100	

- All I/O pins are in input mode with a static value at  $V_{DD}$  or  $V_{SS}$ . Clock input (OSCIN) is driven by external square wave.
- CPU running with memory access, all I/O pins in input mode with a static value at  $V_{DD}$  or  $V_{SS}$ ; clock input (OSCIN) driven by external square wave.

### 4.2.4 I/O port pin characteristics

[Table 8](#) characteristics are measured at  $T_A=0$  to  $+70^\circ\text{C}$ . Voltages are referred to  $V_{SS}$  unless otherwise specified.

**Table 8. I/O port pins characteristics**

Symbol	Parameter	Conditions	Min	Typ	Max	Unit
$V_{IL}$	Input low level voltage	$V_{DD} = 5$ V			$0.3V_{DD}$	V
$V_{IH}$	Input high level voltage	$V_{DD} = 5$ V	$0.7V_{DD}$			
$V_{HYS}$	Schmidt trigger voltage hysteresis <sup>(1)</sup>			400		mV
$V_{OL}$	Output low level voltage for Standard I/O port pins	$I = -5$ mA			1.3	V
		$I = -2$ mA			0.4	
$V_{OH}$	Output high level voltage	$I = 3$ mA	$V_{DD} - 0.8$			
$I_L$	Input leakage current	$V_{SS} < V_{PIN} < V_{DD}$			1	$\mu\text{A}$
$R_{PU}$	Pull-up equivalent resistor		50	90	170	k $\Omega$

**Table 8. I/O port pins characteristics (continued)**

Symbol	Parameter	Conditions	Min	Typ	Max	Unit
t <sub>OHL</sub>	Output high to low level fall time for high sink I/O port pins (Port D) <sup>(2)</sup>	C <sub>I</sub> =50 pF	6	8	13	ns
t <sub>OHL</sub>	Output high to low level fall time for standard I/O port pins (Port A, B or C) <sup>(2)</sup>		18		23	
t <sub>OLH</sub>	Output low-high rise time (Port D) <sup>(2)</sup>		7	9	14	
t <sub>OLH</sub>	Output low-high rise time for standard I/O port pins (Port A, B or C) <sup>(2)</sup>		19		28	
t <sub>ITEXT</sub>	External interrupt pulse time		1			t <sub>CPU</sub>

1. Hysteresis voltage between Schmitt trigger switching levels. Based on characterization results, not tested.
2. Guaranteed by design, not tested in production.

### 4.3 Supply and reset characteristics

Table 9 characteristics are measured for T<sub>A</sub> = 0 to +70 °C, and V<sub>DD</sub> - V<sub>SS</sub> = 5.5 V unless otherwise specified.

**Table 9. Low voltage detector and supervisor (LVDs)**

Symbol	Parameter	Conditions	Min	Typ	Max	Unit
V <sub>IT+</sub>	Reset release threshold (V <sub>DD</sub> rising)			3.7	3.9	V
V <sub>IT-</sub>	Reset generation threshold (V <sub>DD</sub> falling)		3.3	3.5		V
V <sub>hys</sub>	Hysteresis V <sub>IT+</sub> - V <sub>IT-</sub> <sup>(1)</sup>			200		mV
V <sub>tPOR</sub>	V <sub>DD</sub> rise time rate <sup>(1)</sup>		20			ms/V

1. Hysteresis voltage between Schmitt trigger switching levels. Based on characterization results, not tested.

### 4.4 Clock and timing characteristics

#### 4.4.1 General timings

Table 10 are measured at T<sub>A</sub>=0 to +70 °C unless otherwise specified.

**Table 10. General timings**

Symbol	Parameter	Conditions	Min	Typ <sup>(1)</sup>	Max	Unit
t <sub>c(INST)</sub>	Instruction cycle time		2	3	12	t <sub>CPU</sub>
		f <sub>CPU</sub> =4 MHz	500	750	3000	ns
t <sub>v(IT)</sub>	Interrupt reaction time t <sub>v(IT)</sub> = Δt <sub>c(INST)</sub> + 10 <sup>(2)</sup>		10		22	t <sub>CPU</sub>
		f <sub>CPU</sub> =4 MHz	2.5		5.5	μs

1. Data based on typical application software.
2. Time measured between interrupt event and interrupt vector fetch. Δt<sub>c(INST)</sub> is the number of t<sub>CPU</sub> cycles needed to finish the current instruction execution.

### 4.4.2 External clock source

**Table 11. External clock source characteristics**

Symbol	Parameter	Conditions	Min	Typ	Max	Unit
$V_{OSCINH}$	OSCIN input pin high level voltage	see <a href="#">Figure 4</a>	$0.7V_{DD}$		$V_{DD}$	V
$V_{OSCINL}$	OSCIN input pin low level voltage		$V_{SS}$		$0.3V_{DD}$	
$t_w(OSCINH)$ $t_w(OSCINL)$	OSCIN high or low time <sup>(1)</sup>		15			ns
$t_r(OSCIN)$ $t_f(OSCIN)$	OSCIN rise or fall time				15	
$I_L$	OSCx Input leakage current	$V_{SS} \leq V_{IN} \leq V_{DD}$			$\pm 1$	$\mu A$

1. Data based on design simulation and/or technology characteristics, not tested in production.

**Figure 4. Typical application with an external clock source**

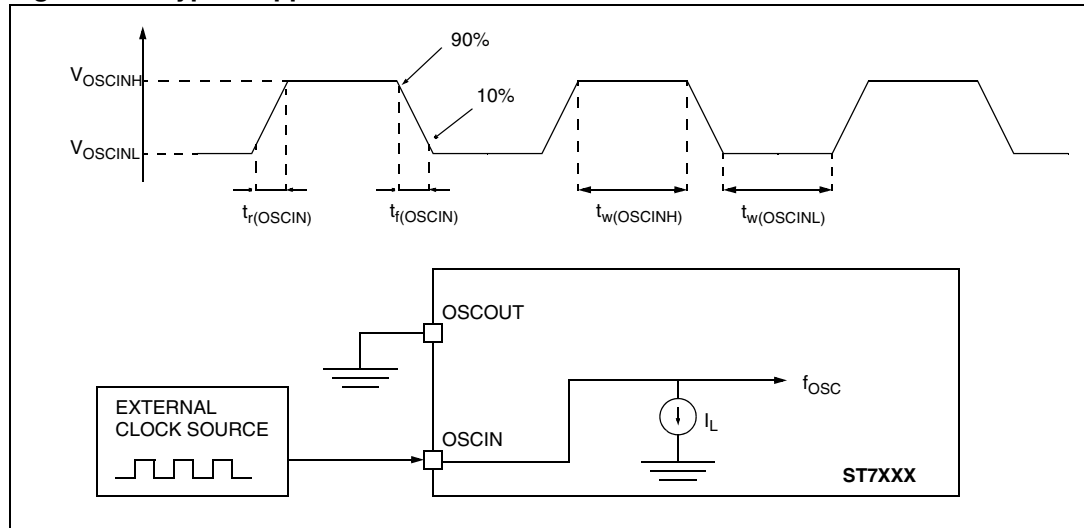

### 4.4.3 Crystal resonator oscillators

The ST7 internal clock is supplied with one Crystal resonator oscillator. All the information given in this paragraph are based on characterization results with specified typical external components. In the application, the resonator and the load capacitors have to be placed as close as possible to the oscillator pins in order to minimize output distortion and start-up stabilization time. Refer to the crystal resonator manufacturer for more details (frequency, package, accuracy...).

**Table 12. Crystal resonator characteristics**

Symbol	Parameter	Conditions		Min	Typ	Max	Unit
f <sub>OSC</sub>	Oscillator Frequency <sup>(1)</sup>	MP: Medium power oscillator			4		MHz
R <sub>F</sub>	Feedback resistor			90		150	kΩ
C <sub>L1</sub> C <sub>L2</sub>	Recommended load capacitances versus equivalent serial resistance of the crystal resonator (R <sub>S</sub> )	See <a href="#">Table 14</a>	(MP oscillator)	22		56	pF
i <sub>2</sub>	OSCOUT driving current	V <sub>DD</sub> =5 V V <sub>IN</sub> =V <sub>SS</sub>	(MP oscillator)	1.5		3.5	mA

1. The oscillator selection can be optimized in terms of supply current using an high quality resonator with small R<sub>S</sub> value. Contact crystal resonator manufacturer for more details.

**Table 13. Typical crystal resonator characteristics**

Oscillator		Reference		Freq.	Characteristic <sup>(1)</sup>	C <sub>L1</sub> (pF)	C <sub>L2</sub> (pF)	t <sub>SU(OSC)</sub> (ms) <sup>(2)</sup>
Crystal	MP	JAUCH	SS3-400-30-30/30	4 MHz	Δf <sub>OSC</sub> =[±30ppm <sub>25°C</sub> ,±30ppm <sub>ΔTa</sub> ] (Typ) R <sub>S</sub> =60 Ω	33	33	7~10

1. Resonator characteristics given by the crystal resonator manufacturer.
2. t<sub>SU(OSC)</sub> is the typical oscillator start-up time measured between V<sub>DD</sub> = 2.8 V and the fetch of the first instruction (with a quick V<sub>DD</sub> ramp-up from 0 to 5 V (<50 μs)).

**Table 14. Recommended values for 4 MHz crystal resonator**

Symbol	Min	Typ	Max
R <sub>S</sub> MAX <sup>(1)</sup>	20 Ω	25 Ω	70 Ω
C <sub>OSCIN</sub>	56 pF	47 pF	22 pF
C <sub>OSCOUT</sub>	56 pF	47 pF	22 pF

1. R<sub>S</sub>MAX is the equivalent serial resistor of the crystal (see crystal specification).

Figure 5. Typical application with a crystal resonator

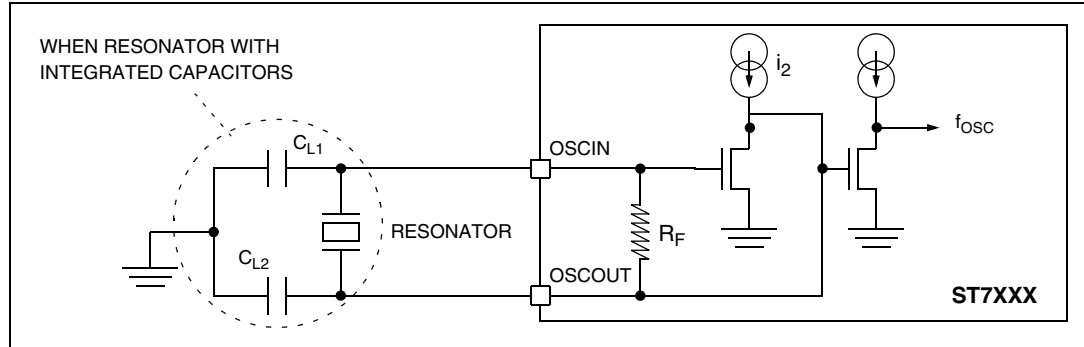

### 4.5 Memory characteristics

Subject to general operating conditions for  $V_{DD}$ ,  $f_{OSC}$ , and  $T_A$  unless otherwise specified.

Table 15. RAM and hardware registers characteristics

Symbol	Parameter	Conditions	Min	Typ	Max	Unit
$V_{RM}$	Data retention mode <sup>(1)</sup>	Halt mode (or Reset)	2			V

1. Minimum  $V_{DD}$  supply voltage without losing data stored in RAM (in Halt mode or under Reset) or in hardware registers (only in Halt mode). Not tested in production.

### 4.6 Smartcard supply supervisor electrical characteristics

Table 16 characteristics are measured for  $T_A = 0$  to  $+70$  °C, and  $4.0 < V_{DD} - V_{SS} < 5.5$  V unless otherwise specified.

Table 16. Smartcard supply supervisor electrical characteristics

Symbol	Parameter	Conditions	Min	Typ	Max	Unit
<b>3 V regulator output (for IEC7816-3 class B cards)</b>						
$V_{CRDVCC}$	Smartcard power supply voltage		2.7	3.0	3.3	V
$I_{SC}$	Smartcard supply current				50	mA
$I_{OVDET}$	Current overload detection				100 <sup>(1)</sup>	mA
$t_{IDET}$	Detection time on current overload		170 <sup>(1)</sup>		1400 <sup>(1)</sup>	µs
$t_{OFF}$	$V_{CRDVCC}$ turn off time	$C_{LOADmax} \leq 4.7 \mu F$			750	µs
$t_{ON}$	$V_{CRDVCC}$ turn on time	$C_{LOADmax} \leq 4.7 \mu F$		150	500	µs
<b>1.8 V regulator output (for IEC7816-3 Class C cards)</b>						
$V_{CRDVCC}$	Smartcard power supply voltage		1.65	1.8	1.95	V
$I_{SC}$	Smartcard supply current				20	mA
$I_{OVDET}$	Current overload detection				100 <sup>(1)</sup>	mA
$t_{IDET}$	Detection time on current overload		170 <sup>(1)</sup>		1400 <sup>(1)</sup>	µs
$t_{OFF}$	$V_{CRDVCC}$ turn off time	$C_{LOADmax} \leq 4.7 \mu F$			750	µs

**Table 16. Smartcard supply supervisor electrical characteristics (continued)**

Symbol	Parameter	Conditions	Min	Typ	Max	Unit
$t_{ON}$	$V_{CRDVCC}$ turn on time	$C_{LOADmax} \leq 4.7 \mu F$		150	500	$\mu s$
<b>Smartcard CLKpin</b>						
$V_{OL}$	Output low level voltage	$I = -50 \mu A$	-	-	$0.4^{(1)}$	V
$V_{OH}$	Output high level voltage	$I = 50 \mu A$	$V_{CRDVCC} - 0.5^{(1)}$	-	-	V
$T_{OHL}$	Output high-low fall time <sup>(1)</sup>	$C_I = 30 pF$	-		20	ns
$T_{OLH}$	Output low-high rise time <sup>(1)</sup>	$C_I = 30 pF$	-		20	ns
$F_{VAR}$	Frequency variation <sup>(1)</sup>		-		1	%
$F_{DUTY}$	Duty cycle <sup>(1)</sup>		45		55	%
$P_{OL}$	Signal low perturbation <sup>(1)</sup>		-0.25		0.4	V
$P_{OH}$	Signal high perturbation <sup>(1)</sup>		$V_{CRDVCC} - 0.5$		$V_{CRDVCC} + 0.25$	V
$I_{SGND}$	Short-circuit to ground <sup>(1)</sup>			15		mA
<b>Smartcard I/O pin</b>						
$V_{IL}$	Input low level voltage		-	-	$0.5^{(1)}$	V
$V_{IH}$	Input high level voltage		$0.6V_{CRDVCC}^{(1)}$	-	-	V
$V_{OL}$	Output low level voltage	$I = -0.5 mA$	-	-	$0.4^{(1)}$	V
$V_{OH}$	Output high level voltage	$I = 20 \mu A$	$0.8V_{CRDVCC}^{(1)}$	-	$V_{CRDVCC}^{(1)}$	V
$I_L$	Input leakage current <sup>(1)</sup>	$V_{SS} < V_{IN} < V_{SC\_PWR}$	-10	-	10	$\mu A$
$I_{RPU}$	Pull-up equivalent resistance	$V_{IN} = V_{SS}$		24	30	k $\Omega$
$T_{OHL}$	Output high-low fall time <sup>(1)</sup>	$C_I = 30 pF$	-		0.8	$\mu s$
$T_{OLH}$	Output low-high rise time <sup>(1)</sup>	$C_I = 30 pF$	-		0.8	$\mu s$
$I_{SGND}$	Short-circuit to ground <sup>(1)</sup>			15		mA
<b>Smartcard RST C4 and C8 pin</b>						
$V_{OL}$	Output low level voltage	$I = -0.5 mA$	-	-	$0.4^{(1)}$	V
$V_{OH}$	Output high level voltage	$I = 20 \mu A$	$V_{CRDVCC} - 0.5^{(1)}$	-	$V_{CRDVCC}^{(1)}$	V
$T_{OHL}$	Output high-low fall time <sup>(1)</sup>	$C_I = 30 pF$	-		0.8	$\mu s$
$T_{OLH}$	Output low-high rise time <sup>(1)</sup>	$C_I = 30 pF$	-		0.8	$\mu s$
$I_{SGND}$	Short-circuit to ground <sup>(1)</sup>			15		mA

1. Data based on characterization results, not tested in production.

## 4.7 EMC characteristics

Susceptibility tests are performed on a sample basis during product characterization.

### 4.7.1 Functional EMS (electromagnetic susceptibility)

Based on a simple running application on the product (toggling 2 LEDs through I/O ports), the product is stressed by two electromagnetic events until a failure occurs (indicated by the LEDs).

- **ESD:** electrostatic discharge (positive and negative) is applied on all pins of the device until a functional disturbance occurs. This test conforms with the IEC 1000-4-2 standard.
- **FTB:** A Burst of Fast Transient voltage (positive and negative) is applied to  $V_{DD}$  and  $V_{SS}$  through a 100 pF capacitor, until a functional disturbance occurs. This test conforms with the IEC 1000-4-4 standard.

A device reset allows normal operations to be resumed. The test results are given in the table below based on the EMS levels and classes defined in application note AN1709.

#### Designing hardened software to avoid noise problems

EMC characterization and optimization are performed at component level with a typical application environment and simplified MCU software. It should be noted that good EMC performance is highly dependent on the user application and the software in particular.

Therefore it is recommended that the user applies EMC software optimization and pre-qualification tests in relation with the EMC level requested for his application.

- Software recommendations
  - The software flowchart must include the management of runaway conditions such as:
    - Corrupted program counter
    - Unexpected reset
    - Critical Data corruption (control registers...)
- Pre-qualification trials
  - Most of the common failures (unexpected reset and program counter corruption) can be reproduced by manually forcing a low state on the Reset pin or the Oscillator pins for 1 second.
  - To complete these trials, ESD stress can be applied directly on the device, over the range of specification values. When unexpected behavior is detected, the software can be hardened to prevent unrecoverable errors occurring (see application note AN1015).

**Table 17. EMS characteristics**

Symbol	Parameter	Conditions	Level/class
$V_{FESD}$	Voltage limits to be applied on any I/O pin to induce a functional disturbance	$V_{DD}=5\text{ V}$ , $T_A=+25\text{ °C}$ , $f_{OSC}=8\text{ MHz}$ conforms to IEC 1000-4-2	2B
$V_{FFTB}$	Fast transient voltage burst limits to be applied through 100 pF on $V_{DD}$ and $V_{DD}$ pins to induce a functional disturbance	$V_{DD}=5\text{ V}$ , $T_A=+25\text{ °C}$ , $f_{OSC}=8\text{ MHz}$ conforms to IEC 1000-4-4	4B

### 4.7.2 Electromagnetic interference (EMI)

Based on a simple application running on the product (toggling 2 LEDs through the I/O ports), the product is monitored in terms of emission. This emission test is in line with the norm SAE J 1752/3 which specifies the board and the loading of each pin.

**Table 18. EMI characteristics**

Symbol	Parameter	Conditions	Monitored frequency band	Max vs. [f <sub>osc</sub> /f <sub>cpu</sub> ] <sup>(1)</sup>		Unit
				4/8MHz	4/4MHz	
S <sub>EMI</sub>	Peak level	V <sub>DD</sub> =5 V, T <sub>A</sub> =+25 °C, conforming to SAE J 1752/3	0.1 MHz to 30 MHz	19	18	dB $\mu$ V
			30 MHz to 130 MHz	32	27	
			130 MHz to 1 GHz	31	26	
			SAE EMI Level	4	3.5	-

1. Data based on characterization results, not tested in production.

### 4.7.3 Absolute maximum ratings (electrical sensitivity)

Based on three different tests (ESD, LU and DLU) using specific measurement methods, the product is stressed in order to determine its performance in terms of electrical sensitivity. For more details, refer to the application note AN1181.

#### Electrostatic discharge (ESD)

Electrostatic discharges (a positive then a negative pulse separated by 1 second) are applied to the pins of each sample according to each pin combination. The sample size depends on the number of supply pins in the device (3 parts\*(n+1) supply pin). The Human Body Model is simulated. This test conforms to the JESD22-A114A standard.

**Table 19. Absolute maximum ratings**

Symbol	Ratings	Conditions	Maximum value <sup>(1)</sup>	Unit
V <sub>ESD(HBM)</sub>	Electrostatic discharge voltage (Human body model)	T <sub>A</sub> =+25 °C	2000	V

1. Data based on characterization results, not tested in production.

#### Static and dynamic latch-up

- **LU:** 3 complementary static tests are required on 10 parts to assess the latch-up performance. A supply over-voltage (applied to each power supply pin) and a current injection (applied to each input, output and configurable I/O pin) are performed on each sample. This test conforms to the EIA/JESD 78 IC latch-up standard. For more details, refer to the application note AN1181.
- **DLU:** Electrostatic discharges (one positive then one negative test) are applied to each pin of 3 samples when the micro is running to assess the latch-up performance in dynamic mode. Power supplies are set to the typical values, the oscillator is connected

as near as possible to the pins of the micro and the component is put in reset mode. This test conforms to the IEC1000-4-2 and SAEJ1752/3 standards. For more details, refer to the application note AN1181.

**Table 20. Electrical sensitivities**

Symbol	Parameter	Conditions	Class <sup>(1)</sup>
LU	Static latch-up class	$T_A=+25\text{ °C}$	A
DLU	Dynamic latch-up class	$V_{DD}=5.5\text{ V}$ , $f_{OSC}=4\text{ MHz}$ , $T_A=+25\text{ °C}$	A

1. Class description: A Class is an STMicroelectronics internal specification. All its limits are higher than the JEDEC specifications, that means when a device belongs to Class A it exceeds the JEDEC standard. B Class strictly covers all the JEDEC criteria (international standard).

## 4.8 Communication interface characteristics

**Table 21. USB DC electrical characteristics**

Parameter	Symbol	Conditions	Min.	Max.	Unit
Input levels					
Differential input sensitivity	VDI	I(D+, D-)	0.2		V
Differential common mode range	VCM	Includes VDI range	0.8	2.5	V
Single ended receiver threshold	VSE		1.3	2.0	V
Output levels					
Static output low	VOL	RL of 1.5 kΩ to 3.6 V <sup>(1)</sup>		0.3	V
Static output high	VOH	RL of 15 kΩ to V <sub>SS</sub> <sup>(1)</sup>	2.8	3.6	V
USBVCC: voltage level	USBV	$V_{DD}=5\text{ V}$	3.00	3.60	V

1. R<sub>L</sub> is the load connected on the USB drivers. All the voltages are measured from the local ground potential.

**Figure 6. USB data signal rise and fall time**

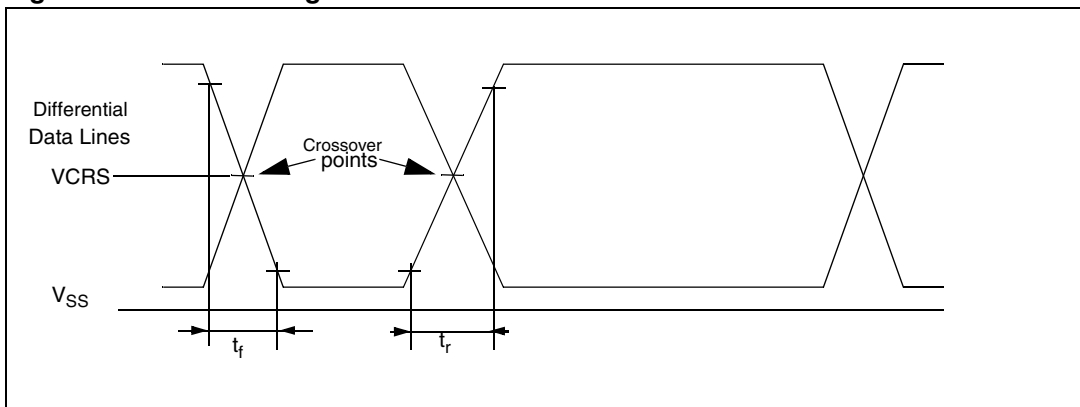

Table 22. USB full-speed electrical characteristics

Parameter	Symbol	Conditions	Min	Max	Unit
Driver characteristics					
Rise time <sup>(1)</sup>	$t_r$	CL=50 pF	4	20	ns
Fall time <sup>(1)</sup>	$t_f$	CL=50 pF	4	20	ns
Rise/ fall time matching	$t_{rfm}$	$t_r/t_f$	90	110	%
Output signal crossover voltage	VCRS		1.3	2.0	V

1. Measured from 10% to 90% of the data signal. For more detailed informations, please refer to Chapter 7 (Electrical) of the USB specification (version 1.1).

## 5 Package characteristics

In order to meet environmental requirements, ST offers this device in different grades of ECOPACK<sup>®</sup> packages, depending on their level of environmental compliance. ECOPACK<sup>®</sup> specifications, grade definitions and product status are available at: [www.st.com](http://www.st.com). ECOPACK<sup>®</sup> is an ST trademark.



## 5.2 Recommended reflow oven profile

Refer to JEDEC specification JSTD020D for a description of the recommended reflow oven profile for these packages.

## 6 Device configuration and ordering information

### Device ordering information and transfer of customer code

Customer code is made up of the ROM contents and the list of the selected options (if any). The ROM contents are to be sent on diskette, or by electronic means, with the hexadecimal file in .S19 format generated by the development tool. All unused bytes must be set to FFh.

The selected options are communicated to STMicroelectronics using the correctly completed option list appended. See [Figure 8: ST7LCR option list](#).

Refer to application note AN1635 for information on the counter listing returned by ST after code has been transferred.

The STMicroelectronics Sales Organization will be pleased to provide detailed information on contractual points.

**Table 24. Ordering information**

Sales type	Program memory (bytes)	RAM (bytes)	Package
ST7LCRE4U1/xxx <sup>(1)</sup>	16K ROM	768	VFQFPN24
ST7LCDIE6/xxx <sup>(1)</sup>	16K ROM	768	Die

1. Customer ROM code name is assigned by STMicroelectronics.

Figure 8. ST7LCR option list

```

ST7LCR MICROCONTROLLER OPTION LIST
(Last update: October 2007)

Customer: . . . . .
Address: . . . . .
Contact: . . . . .
Phone No: . . . . .

Reference/ROM Code* :
*The ROM code name is assigned by STMicroelectronics.
ROM code must be sent in .S19 format. .Hex extension cannot be processed.

Device Type/Memory Size/Package (check only one option)
-----
ROM Device:      |      16K
-----
VFQFPN24:       |      [ ] ST7LCRE4U1
DIE24:          |      [ ] ST7LCRDIE6

Conditioning (check only one option)      :
-----
Packaged Product:      |      Die Product
-----
[ ] Tray (VFQFPN package only) |      [ ] Tape & Reel
|      [ ] Waffle pack
|      [ ] Sawn wafer on sticky foil
|      [ ] Inked wafer

Special Marking: [ ] No      [ ] Yes " _ _ _ _ _ "
Authorized characters are letters, digits, '.', '-', '/', and spaces only.

Maximum character count: VFQFPN24 (7 char. max) : _ _ _ _ _

Vcc Card:          CRDVCC      [ ] 1.8V
|                  |          [ ] 3.0V

Watchdog:          WDGSW      [ ] Software Activation
|                  |          [ ] Hardware Activation
Nested Interrupts  NEST       [ ] Nested Interrupts
|                  |          [ ] Non Nested Interrupts
ISO Clock Source   ISOCLK     [ ] Oscillator
|                  |          [ ] Divider
No. of Retries     RETRY      [ ] 5
|                  |          [ ] 4
Readout Protection: FMP_R     [ ] Disabled
|                  |          [ ] Enabled

Date      . . . . .      Signature . . . . .

```

## 7 Revision history

**Table 25. Document revision history**

Date	Revision	Changes
26-Aug-06	0.1	Initial release
26-Mar-07	0.2	QFN24 package added Option List added External clock source frequency modified (to maximum value), <a href="#">Section 4.2</a> Die sales type added to <a href="#">Table</a> Note added to <a href="#">Table 2</a> (NC pins must be connected to ground)
23-Oct-2007	1	Document reformatted. Replaced ST7LCR by ST7LCRE4U1 and ST7LCRDIE6. ECOPACK text added. Changed “selectable card V <sub>CC</sub> ” into “fixed card V <sub>CC</sub> ”. 5 V removed in <a href="#">Section : Features</a> , <a href="#">Section 3: ST7LCR implementation</a> and <a href="#">Table 16: Smartcard supply supervisor electrical characteristics</a> . Changed QFN24 into VFQFPN24. Added <a href="#">Figure 6: Device configuration and ordering information</a> . CRDC4 and CRDC8 renamed C4 and C8 respectively in <a href="#">Figure 1: ST7LCR block diagram</a> . Removed LED functional block and LEDO pin from <a href="#">Figure 1: ST7LCR block diagram</a> . LEDO pin left unconnected in <a href="#">Figure 2: 24-lead VFQFPN package pinout</a> and <a href="#">Table 2: Pin description</a> , and <a href="#">Figure 3: Smartcard interface reference application - VFQFPN24 pin block diagram</a> . Removed mention of external LEDs in <a href="#">Section 3.1: Functionality</a> . SLEF and DIODE pins removed from <a href="#">Figure 1: ST7LCR block diagram</a> , and left unconnected in <a href="#">Figure 2: 24-lead VFQFPN package pinout</a> , <a href="#">Table 2: Pin description</a> , and <a href="#">Figure 3: Smartcard interface reference application - VFQFPN24 pin block diagram</a> . Removed LED pin characteristics table. Added <a href="#">Figure 6: Device configuration and ordering information</a> . Updated <a href="#">Figure 8: ST7LCR option list</a> .
23-Jun-2008	2	Updated smartcard power supply in <a href="#">Section : Features</a> to removed step-up converter.
19-Feb-2009	3	Updated smartcard supply voltage description in <a href="#">Features</a> , <a href="#">Section 1: Device overview</a> , and <a href="#">Section 3.1: Functionality</a> . Removed recommended reflow oven profile in <a href="#">Section 5: Package characteristics</a> .

**Please Read Carefully:**

Information in this document is provided solely in connection with ST products. STMicroelectronics NV and its subsidiaries ("ST") reserve the right to make changes, corrections, modifications or improvements, to this document, and the products and services described herein at any time, without notice.

All ST products are sold pursuant to ST's terms and conditions of sale.

Purchasers are solely responsible for the choice, selection and use of the ST products and services described herein, and ST assumes no liability whatsoever relating to the choice, selection or use of the ST products and services described herein.

No license, express or implied, by estoppel or otherwise, to any intellectual property rights is granted under this document. If any part of this document refers to any third party products or services it shall not be deemed a license grant by ST for the use of such third party products or services, or any intellectual property contained therein or considered as a warranty covering the use in any manner whatsoever of such third party products or services or any intellectual property contained therein.

**UNLESS OTHERWISE SET FORTH IN ST'S TERMS AND CONDITIONS OF SALE ST DISCLAIMS ANY EXPRESS OR IMPLIED WARRANTY WITH RESPECT TO THE USE AND/OR SALE OF ST PRODUCTS INCLUDING WITHOUT LIMITATION IMPLIED WARRANTIES OF MERCHANTABILITY, FITNESS FOR A PARTICULAR PURPOSE (AND THEIR EQUIVALENTS UNDER THE LAWS OF ANY JURISDICTION), OR INFRINGEMENT OF ANY PATENT, COPYRIGHT OR OTHER INTELLECTUAL PROPERTY RIGHT.**

**UNLESS EXPRESSLY APPROVED IN WRITING BY AN AUTHORIZED ST REPRESENTATIVE, ST PRODUCTS ARE NOT RECOMMENDED, AUTHORIZED OR WARRANTED FOR USE IN MILITARY, AIR CRAFT, SPACE, LIFE SAVING, OR LIFE SUSTAINING APPLICATIONS, NOR IN PRODUCTS OR SYSTEMS WHERE FAILURE OR MALFUNCTION MAY RESULT IN PERSONAL INJURY, DEATH, OR SEVERE PROPERTY OR ENVIRONMENTAL DAMAGE. ST PRODUCTS WHICH ARE NOT SPECIFIED AS "AUTOMOTIVE GRADE" MAY ONLY BE USED IN AUTOMOTIVE APPLICATIONS AT USER'S OWN RISK.**

Resale of ST products with provisions different from the statements and/or technical features set forth in this document shall immediately void any warranty granted by ST for the ST product or service described herein and shall not create or extend in any manner whatsoever, any liability of ST.

ST and the ST logo are trademarks or registered trademarks of ST in various countries.

Information in this document supersedes and replaces all information previously supplied.

The ST logo is a registered trademark of STMicroelectronics. All other names are the property of their respective owners.

© 2009 STMicroelectronics - All rights reserved

STMicroelectronics group of companies

Australia - Belgium - Brazil - Canada - China - Czech Republic - Finland - France - Germany - Hong Kong - India - Israel - Italy - Japan - Malaysia - Malta - Morocco - Singapore - Spain - Sweden - Switzerland - United Kingdom - United States of America

[www.st.com](http://www.st.com)