



ST7GEME4

Full-speed USB MCU with smartcard firmware and EMV/non-EMV interface

Features

- Clock, reset and supply management
 - Low voltage reset
 - Halt power saving mode
 - PLL for generating 48 MHz USB clock using a 4 MHz crystal
- USB (Universal Serial Bus) interface
 - USB 2.0 compliant
 - CCID V1.0
 - Full speed, hubless
 - Bus-powered, low consumption
- Serial RS232 interface
 - Transmission rate: 9.6 Kbps to 115 Kbps
 - Format: 8-bit, no parity
 - Auto baud rate
 - CCID V1.0 on serial TTL link
- ISO 7816-3 UART interface
 - 4 Mhz clock generation
 - Synchronous/Asynchronous protocols (T=0, T=1)
 - Automatic retry on parity error
 - Programmable baud rate from 372 to 11.625 clock pulses (D=32/F=372)
 - Card insertion/removal detection
- Smartcard power supply
 - Selectable card V_{CC} : 1.8 V, 3 V, and 5 V

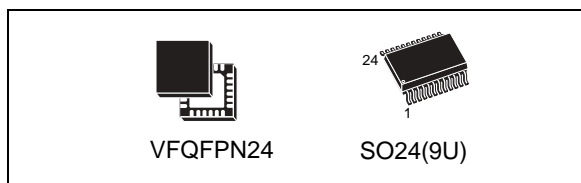

- Internal Step-up converter for 5V supplied Smartcards (with a current of up to 55mA) using only two external components.
- Programmable smartcard internal voltage regulator (1.8 to 3.0 V) with current overload protection and 4 kV ESD protection (Human Body Model) for all smartcard interface I/Os
- Development tools
 - Application note on PCB recommendations and component bill of materials
 - Full hardware/software kit for performance evaluation

Description

The ST7GEME4 is an 8-bit microcontroller dedicated to smartcard reading applications. It has been developed to be the core of smartcard readers communicating through a serial or USB link. It is pre-programmed using Gemplus software, and offers a single integrated circuit solution with very few external components.

Table 1. Device summary

Features	Order codes	
	ST7GEME4M1	ST7GEME4U1
Program memory	16K ROM	
User RAM + USB data buffer (bytes)	512 + 256	
Peripherals	USB Full-Speed (7 Ep), TBU, Watchdog timer, ISO 7816-3 Interface	
Operating Supply	4.0 to 5.5 V	
Package	SO24	VFQFPN24
CPU Frequency	4 or 8 MHz	
Operating temperature	0 to +70 °C	

Contents

- 1 Introduction 5**
- 2 Pin description 7**
- 3 ST7GEME4 implementation 10**
 - 3.1 Functionality 10
 - 3.2 Smartcard interface features 10
 - 3.3 EMV versus PC/SC-ISO mode 11
- 4 Electrical characteristics 13**
 - 4.1 Absolute maximum ratings 13
 - 4.2 Recommended operating conditions 14
 - 4.3 Supply and reset characteristics 16
 - 4.4 Clock and timing characteristics 16
 - 4.4.1 General timings 16
 - 4.4.2 Crystal resonator oscillators 18
 - 4.5 Memory characteristics 19
 - 4.6 Smartcard supply supervisor electrical characteristics 19
 - 4.7 EMC characteristics 21
 - 4.7.1 Functional EMS (electromagnetic susceptibility) 21
 - 4.7.2 Electromagnetic interference (EMI) 22
 - 4.7.3 Absolute maximum ratings (electrical sensitivity) 23
 - 4.8 Communication interface characteristics 24
- 5 Package characteristics 25**
 - 5.1 Package mechanical data 25
- 6 Revision history 27**

List of tables

Table 1.	Device summary	1
Table 2.	Pin description	8
Table 3.	Technical features	11
Table 4.	Absolute maximum ratings	13
Table 5.	Thermal characteristics	14
Table 6.	General operating conditions	14
Table 7.	Current injection on I/O port and control pins	14
Table 8.	Current consumption	15
Table 9.	I/O port pins characteristics	15
Table 10.	LED pins characteristics	16
Table 11.	Low voltage detector and supervisor characteristics (LVDS)	16
Table 12.	General timings	16
Table 13.	External clock source	17
Table 14.	Crystal resonator oscillator characteristics	18
Table 15.	Typical crystal resonator characteristics	18
Table 16.	Recommended values for 4 MHz crystal resonator	18
Table 17.	RAM and hardware registers	19
Table 18.	Smartcard supply supervisor characteristics	19
Table 19.	EMS characteristics	22
Table 20.	EMI characteristics	22
Table 21.	Absolute maximum ratings	23
Table 22.	Electrical sensitivities	23
Table 23.	USB DC electrical characteristics	24
Table 24.	USB full speed electrical characteristics	24
Table 25.	24-lead very thin fine pitch quad flat no-lead 5x5mm,0.65mm pitch, mechanical data.	25
Table 26.	24-pin plastic small outline package- 300-mil width, mechanical data	26
Table 27.	Document revision history	27

List of figures

Figure 1.	ST7GEME4 block diagram	6
Figure 2.	24-lead VFQFPN package pinout	7
Figure 3.	24-pin SO package pinout	7
Figure 4.	Smartcard interface reference application - 24-pin SO package	9
Figure 5.	Typical application with an external clock source	17
Figure 6.	Typical application with a crystal resonator	19
Figure 7.	USB data signal rise and fall time	24
Figure 8.	24-lead very thin fine pitch quad flat no-lead 5x5 mm 0.65 mm pitch, package outline . . .	25
Figure 9.	24-pin plastic small outline package- 300-mil width, package outline.	26

1 Introduction

The ST7GEME4 device is a member of the ST7 microcontroller family designed for USB applications. All devices are based on a common industry-standard 8-bit core, featuring an enhanced instruction set.

The ST7GEME4 is factory-programmed ROM devices and as such are not reprogrammable.

It operates at a 4 MHz external oscillator frequency.

Under software control, all devices can be placed in Halt mode, reducing power consumption when the application is in idle or stand-by state.

The enhanced instruction set and addressing modes of the ST7 offer both power and flexibility to software developers, enabling the design of highly efficient and compact application code. In addition to standard 8-bit data management, all ST7 microcontrollers feature true bit manipulation, 8x8 unsigned multiplication and indirect addressing modes.

The ST7GEME4 includes an ST7 Core, up to 16 Kbytes of program memory, up to 512 bytes of user RAM and the following on-chip peripherals:

- USB full speed interface with 7 endpoints, programmable in/out configuration and embedded 3.3 V voltage regulator and transceivers (no external components are needed).
- ISO 7816-3 UART interface with programmable baud rate from 372 clock pulses up to 11.625 clock pulses
- Smartcard supply block able to provide programmable supply voltage and I/O voltage levels to the smartcards
- Low voltage reset ensuring proper power-on or power-off of the device (selectable by option)
- 8-bit timer (TBU)

Figure 1. ST7GEME4 block diagram

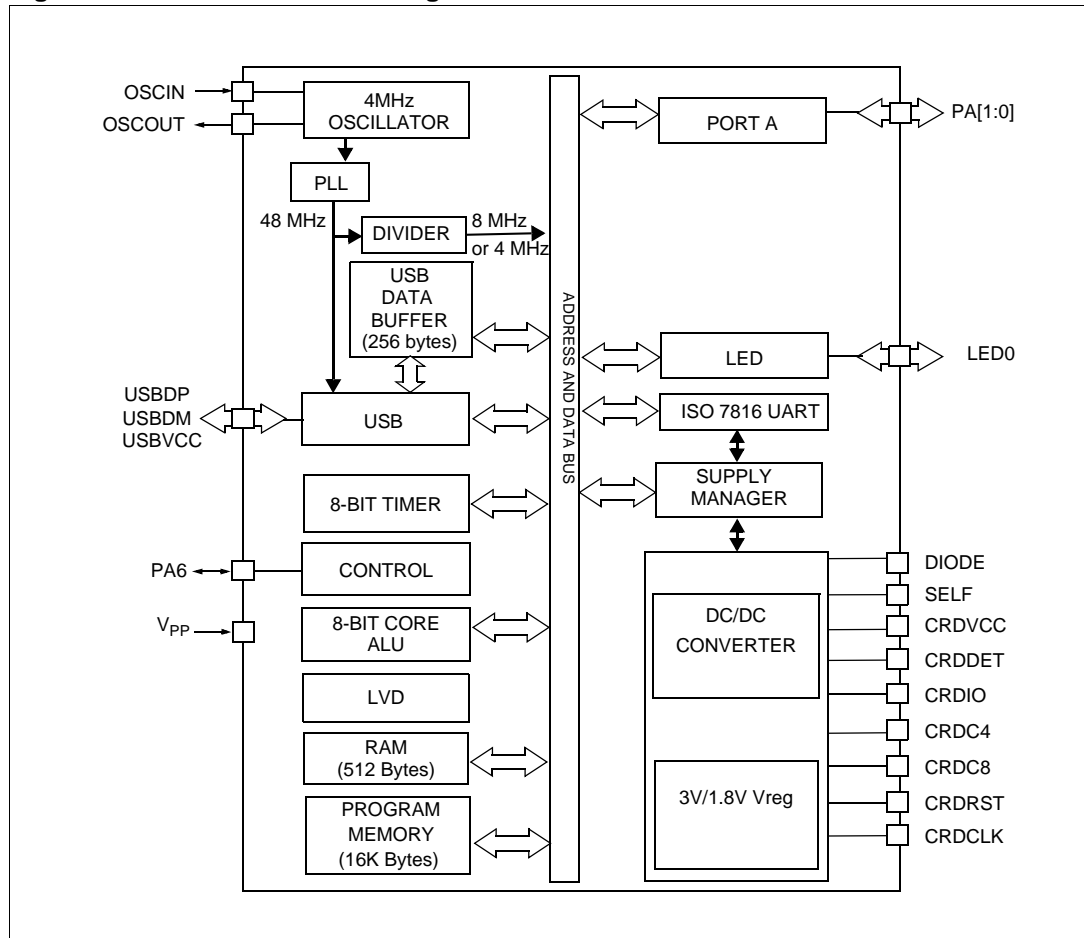

2 Pin description

Figure 2. 24-lead VFQFPN package pinout

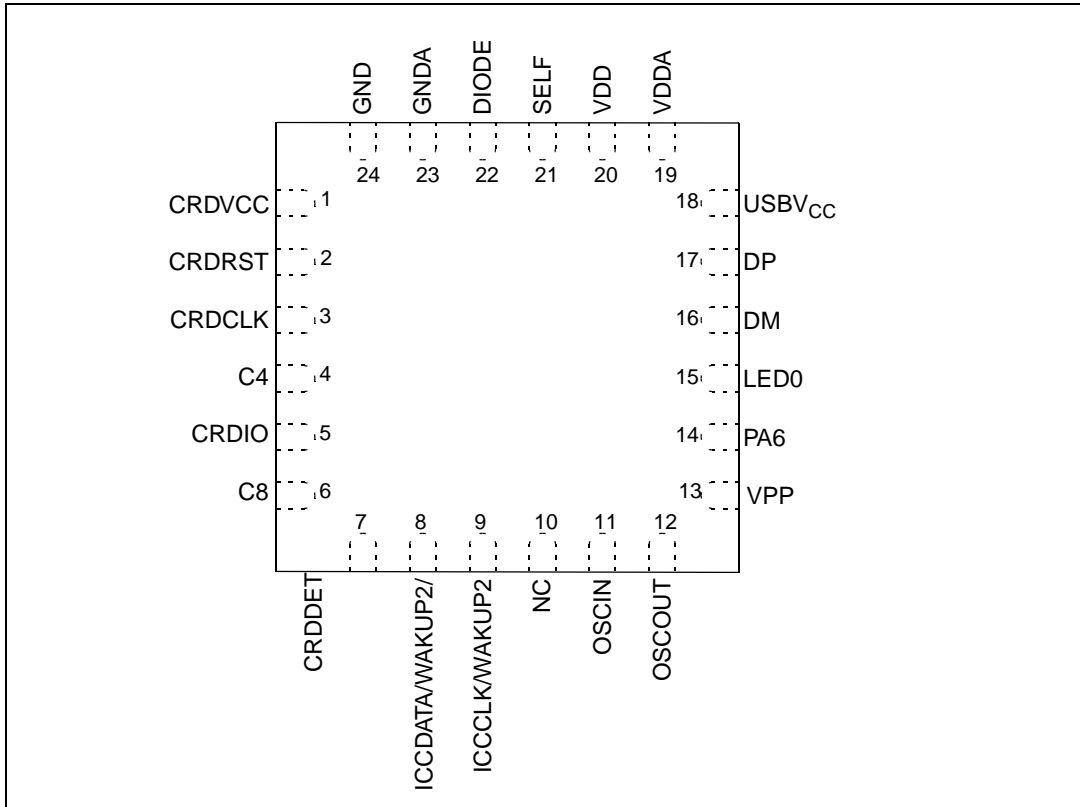
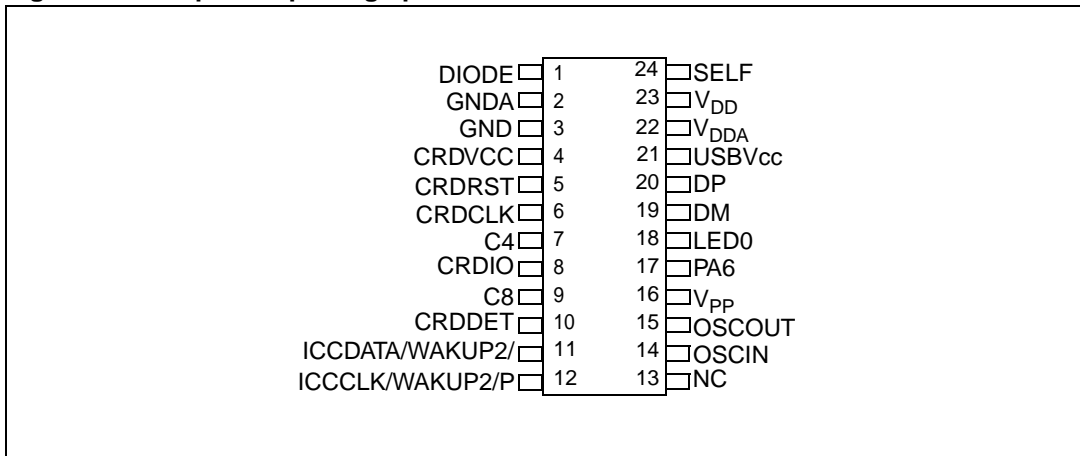

Figure 3. 24-pin SO package pinout



Legend / Abbreviations

- Type: I = input, O = output, S = supply
- In/Output level: C_T = CMOS 0.3VDD/0.7VDD with input trigger
- Output level: HS = 10mA high sink (on N-buffer only)
- Port and control configuration:
 - Input: float = floating, wpu = weak pull-up, int = interrupt, ana = analog
 - Output: OD = open drain, PP = push-pull

Table 2. Pin description

Pin number		Pin name	Type	Level		V _{CARD} supplied	Port / Control				Main function (after reset)	Alternate function
VFQFPN24	SO24			Input	Output		Input		Output			
							wpu	int	OD	PP		
2	5	CRDRST	O		C _T	X				X	Smartcard reset	
3	6	CRDCLK	O		C _T	X				X	Smartcard clock	
4	7	C4	O		C _T	X				X	Smartcard C4	
5	8	CRDIO	I/O		C _T	X	X		X		Smartcard I/O	
6	9	C8	O		C _T	X				X	Smartcard C8	
7	10	CRDDET	I	C _T			X				Smartcard detection	
8	11	PA0/WAKUP2/ICCDATA	I/O		C _T		X	X	X	X	Port A0	Interrupt, In-circuit communication data input
9	12	PA1/WAKUP2/ICCCLK	I/O		C _T		X	X	X	X	Port A1	Interrupt, In-circuit communication clock input
11	14	OSCIN		C _T							Input/output oscillator pins. These pins connect a 4 MHz parallel-resonant crystal, or an external source to the on-chip oscillator.	
12	15	OSCOU			C _T							
13	16	V _{PP}	S								Must be held low in normal operating mode.	
14	17	PA6	I	C _T							PA6	
15	18	LED0	O		HS				X		Constant current output	
16	19	DM	I/O		C _T						USB Data Minus line	
17	20	DP	I/O		C _T						USB Data Plus line	
18	21	USBVCC	O		C _T						3.3 V output for USB	
19	22	V _{DDA}	S								Power Supply voltage 4-5.5 V	
20	23	V _{DD}	S								Power Supply voltage 4-5.5 V	
21	24	SELF	O		C _T						An external inductance must be connected to these pins for the step up converter	
22	1	DIODE	S		C _T						An external diode must be connected to this pin for the step up converter	

Table 2. Pin description (continued)

Pin number		Pin name	Type	Level		V _{CARD} supplied	Port / Control				Main function (after reset)	Alternate function
VFQFPN24	SO24			Input	Output		Input		Output			
							wpu	int	OD	PP		
23	2	GNDA	S							Ground		
24	3	GND	S									
1	4	CDRVCC	O		C _T	X				Smartcard supply pin		

Figure 4. Smartcard interface reference application - 24-pin SO package

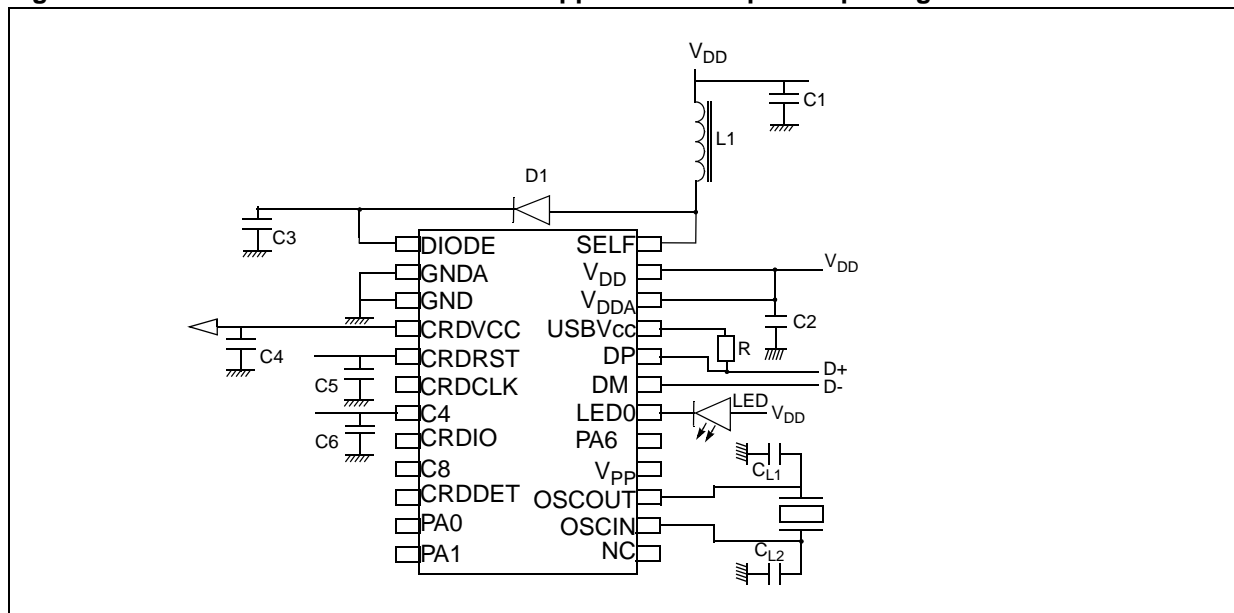

- Mandatory values for the external components:
 C1 = 4.7 μF; C2 = 100 nF. C1 and C2 must be located close to the chip (refer to [Section 4.4.2](#)).
 C3 = 1 nF;
 C4 = 4.7 μF ESR 0.5 Ω.
 C5 : 470 pF;
 C6 : 100 pF;
 R : 1.5kΩ;
 L1 : 10 μH, 2 Ω;
 Crystal 4.0 MHz; Impedance max100 Ω
 D1: BAT42 SHOTTKY.

3 ST7GEME4 implementation

The ST7GEME4 has been developed to offer a complete ready-to-use firmware solution which allows fast development and rapid time-to-market of smartcard reader applications.

It offers a single IC solution and simplifies the integration of smartcard interfaces into electronic devices such as computers, POS terminals, mobile phones, PDAs, home routers, and set-top boxes. Pre-programmed with communication software from our partner GEMPLUS, the ST7GEME4 is a complete firmware solution controlling the communication between ISO 7816 1-2-3-4 cards and a host system. An evaluation kit and reference design with a complete bill of materials and PCB recommendations are available. The ST7GEME4 complies with EMVCo/EMV2000 standards. Software support and engineering expertise in system integration and PCB design are available as additional services.

3.1 Functionality

The core functionality of ST7GEME4 resides in its pre-programmed software embedded in ROM memory. GemCore™ technology manages the communication protocol to/from the host computer and the external card. Basic features and compliance are described in the features section and in [Table 3 on page 11](#).

A dedicated analog block provides smartcard power supplies 1.8 V, 3 V, and 5 V necessary to interface with different card voltages available on the market. Voltages are selected by software. External LEDs can also be directly connected to dedicated I/Os.

A dedicated UART interface provides an ISO 7816 communication port for connection with the smartcard connector. A full-speed USB interface port allows external connection to a host computer. An optional RS232 connection is also available on dedicated I/Os.

3.2 Smartcard interface features

The ST7GEME4 firmware includes the following features:

- Compatibility with asynchronous cards
- Compatibility with T=0 and T=1 protocols
- Compatibility with EMV and PC/SC modes.
- Compatibility with ISO 7816-3 and 4 and ability to supply the cards with 5V, 3V or 1.8V (class A, B or C cards, respectively)
- Resume/wake-up mode upon smartcard insertion/removal

Further details on smartcard management can be found in "Gemcore USB Pro reference manual" from Gemplus.

The reader is able to communicate with smartcards up to the maximum baud rate allowed, namely 344 086 bps (TA1=16) for a clock frequency of 4 MHz. Because the size of the smartcard buffer is 261 bytes, care must be taken not to exceed this size during APDU exchanges when the protocol in use is T=1.

3.3 EMV versus PC/SC-ISO mode

The ST7GEME4 supports two operating modes:

- An EMV mode, based on the EMV4.1 specifications
- A PC/SC-ISO mode which allows to manage of a smartcard according to the PC/SC and ISO 7816-3 standards

The default mode is PC/SC, however, the reader can switch between EMV and PC/SC-ISO modes.

GemCore2000 is a utility in charge of managing the switching between the two modes. When the utility is activated, the reader attempts EMV mode management whenever a smartcard is inserted. If reading is successful, PC/SC mode will not be available.

Caution: The activation of the GemCore2000 utility must be done before any card command. Any activation of the GemCore2000 utility is not recommended unless the reader is reset.

The EMV mode fails if:

- The smartcard has not sent an EMV-compliant answer to reset (ATR)
- Negotiation of the buffer size with a T=1 card has failed

Using PC/SC-ISO mode with GemCore2000

The reader switches to PC/SC mode after the application or the driver has sent the appropriate dedicated command to the reader (with a proprietary Escape command). In this case, the reader remains in PC/SC mode as long as the card remains in the reader.

Whenever the EMV mode fails, the smartcard is powered off. After the host application has sent the PC/SC switch (proprietary) Escape command, the application must send a new Card Power On command.

When the reader deals with an EMV card, the data exchanged between the reader and the host consists of short APDU messages. When the card is not EMV-compliant and the reader is set to PC/SC-ISO mode, the reader exchanges TPDU messages with the host.

Restriction: character level and the extended APDU are not implemented in ST7GEME4 solution.

Table 3. Technical features

Features	Description	Characteristics
Supported smartcards	Asynchronous	– Microprocessor cards – T=0, T=1 protocols – Transmission rate: 2 Kbps to 344 Kbps
	Synchronous	– Through a comprehensive API
Smartcard electrical interface	Smartcard power supply	– 5V/55mA and 3V/50mA and 1.8V/20mA – Short circuit current limitation – Power up/power down control sequences
	Smartcard management	– Card insertion/extraction detection
	ESD protection on card I/O	– 4 kV Human Body Model

Table 3. Technical features (continued)

Drivers	USB and serial versions	<ul style="list-style-type: none"> – Microsoft Windows 2000/XP/Server 2003 – Microsoft Windows CE 4.1/4.2/5.0 – Linux Red Hat/SUSE/Debian – Microsoft Windows XP 64-bit on AMD64 and EMT64 – Microsoft Windows Server 2003 64-bit – Mac OS 10.3/10.4
	Compliance with class drivers	<ul style="list-style-type: none"> – Microsoft Windows 2000/XP/Server 2003 – Microsoft Windows Vista (beta version) – Mac OS 10.3/10.4
USB interface	USB 2.0 compliant	<ul style="list-style-type: none"> – CCID V1.0 – Full speed, hubless – Bus powered, low consumption
Serial host interface	Serial asynchronous link	<ul style="list-style-type: none"> – Transmission rate: 9.6 Kbps to 115 Kbps – Format: 8-bit, no parity – Auto baud rate
	Communication protocol	– CCID V1.0 on serial TTL link
Other features	Temperature range	<ul style="list-style-type: none"> – Operating range: 0 to +70°C – Storage: -65 to +150°C
	Environmental standard	– RoHS compliant

4 Electrical characteristics

4.1 Absolute maximum ratings

The ST7GEME4 contains circuitry to protect the inputs against damage due to high static voltages. However it is advisable to take normal precautions to avoid applying any voltage higher than the specified maximum rated voltages.

For proper operation it is recommended that V_I and V_O be higher than V_{SS} and lower than V_{DD} . Reliability is enhanced if unused inputs are connected to an appropriate logic voltage level (V_{DD} or V_{SS}).

Power considerations

The average chip-junction temperature, T_J , in Celsius can be obtained by the following equation:

$$T_J = T_A + P_D \times R_{thJA}$$

where:

T_A = Ambient temperature

R_{thJA} = Package thermal resistance (junction-to ambient)

$P_D = P_{INT} + P_{PORT}$

$P_{INT} = I_{DD} \times V_{DD}$ (chip internal power)

P_{PORT} = Port power dissipation determined by the user

Stresses above those listed as “absolute maximum ratings” may cause permanent damage to the device. This is a stress rating only and functional operation of the device at these conditions is not implied. Exposure to maximum rating for extended periods may affect device reliability.

Table 4. Absolute maximum ratings

Symbol	Ratings	Value	Unit
$V_{DD} - V_{SS}$	Supply voltage	6.0	V
V_{IN}	Input voltage	$V_{SS} - 0.3$ to $V_{DD} + 0.3$	V
V_{OUT}	Output voltage	$V_{SS} - 0.3$ to $V_{DD} + 0.3$	V
ESD	ESD susceptibility	2000	V
ESDCard	ESD susceptibility for card pads	4000	V
I_{VDD_i}	Total current into V_{DD_i} (source)	250	mA
I_{VSS_i}	Total current out of V_{SS_i} (sink)	250	

Warning: Direct connection to V_{DD} or V_{SS} of the I/O pins could damage the device in case of program counter corruption (due to unwanted change of the I/O configuration). To guarantee safe conditions, this connection has to be done through a typical 10k Ω pull-up or pull-down resistor.

Table 5. Thermal characteristics

Symbol	Ratings		Value	Unit
R _{thJA}	Package thermal resistance	VFQFPN24	42	°C/W
		SO24	80	°C/W
T _{Jmax}	Max. junction temperature		150	°C
T _{STG}	Storage temperature range		-65 to +150	°C
PD _{max}	Power dissipation	VFQFPN24	600	mW
		SO24	500	mW

4.2 Recommended operating conditions

Table 6. General operating conditions

Symbol	Parameter	Conditions	Min	Typ	Max	Unit
V _{DD}	Supply voltage		4.0		5.5	V
f _{OSC}	External clock source			4		MHz
T _A	Ambient temperature range		0		70	°C

Operating conditions are given for T_A = 0 to +70 °C unless otherwise specified.

Table 7. Current injection on I/O port and control pins⁽¹⁾

Symbol	Parameter	Conditions	Min	Typ	Max	Unit
I _{INJ+}	Total positive injected current ⁽²⁾⁽³⁾	V _{EXTERNAL} > V _{DD} (Standard I/Os)			20	mA
		V _{EXTERNAL} > V _{CRDVCC} (Smartcard I/Os)				
I _{INJ-}	Total negative injected current ⁽⁴⁾⁽⁵⁾	V _{EXTERNAL} < V _{SS} Digital pins			20	mA
		V _{EXTERNAL} < V _{SS} Analog pins				

- When several inputs are submitted to a current injection, the maximum injected current is the sum of the positive (resp. negative) currents (instantaneous values).
- Positive injection. The I_{INJ+} is done through protection diodes insulated from the substrate of the die.
- For SmartCard I/Os, V_{CRDVCC} has to be considered.
- The negative injected current, I_{INJ-}, passes through protection diodes which are NOT INSULATED from the substrate of the die. The drawback is a small leakage (few μA) induced inside the die when a negative injection is performed. This leakage is tolerated by the digital structure. The effect depends on the pin which is submitted to the injection. Of course, external digital signals applied to the component must have a maximum impedance close to 50kΩ.
- Location of the negative current injection: Pure digital pins can tolerate 1.6mA. In addition, the best choice is to inject the current as far as possible from the analog input pins.

Table 8 characteristics are measured at $T_A=0$ to $+70^\circ\text{C}$, and $V_{DD}-V_{SS}=5.5\text{V}$ unless otherwise specified.

Table 8. Current consumption⁽¹⁾

Symbol	Parameter	Conditions	Min	Typ.	Max	Unit
I_{DD}	Supply current in RUN mode ⁽²⁾	$f_{OSC} = 4\text{MHz}$		10	15	mA
	Supply current in suspend mode	External $I_{LOAD} = 0\text{mA}$ (USB transceiver enabled)			500	μA
	Supply current in Halt mode	External $I_{LOAD} = 0\text{mA}$ (USB transceiver disabled)		50	100	

- All I/O pins are in input mode with a static value at V_{DD} or V_{SS} ; clock input (OSCIN) driven by external square wave.
- CPU running with memory access, all I/O pins in input mode with a static value at V_{DD} or V_{SS} ; clock input (OSCIN) driven by external square wave.

Table 9 characteristics are measured at $T_A=0$ to $+70^\circ\text{C}$. Voltage are referred to V_{SS} unless otherwise specified.

Table 9. I/O port pins characteristics

Symbol	Parameter	Conditions	Min	Typ	Max	Unit
V_{IL}	Input low level voltage	$V_{DD}=5\text{V}$			$0.3V_{DD}$	V
V_{IH}	Input high level voltage	$V_{DD}=5\text{V}$	$0.7V_{DD}$			
V_{HYS}	Schmidt trigger voltage hysteresis ⁽¹⁾			400		mV
V_{OL}	Output low level voltage for Standard I/O port pins	$I=-5\text{mA}$			1.3	V
		$I=-2\text{mA}$			0.4	
V_{OH}	Output high level voltage	$I=3\text{mA}$	$V_{DD}-0.8$			
I_L	Input leakage current	$V_{SS}<V_{PIN}<V_{DD}$			1	μA
R_{PU}	Pull-up equivalent resistor		50	90	170	$\text{k}\Omega$
t_{OHL}	Output high to low level fall time for high sink I/O port pins (Port D) ⁽²⁾	$C_I=50\text{pF}$	6	8	13	ns
t_{OHL}	Output high to low level fall time for standard I/O port pins (Port A, B or C) ⁽²⁾		18		23	
t_{OLH}	Output L-H rise time (Port D) ⁽²⁾		7	9	14	
t_{OLH}	Output L-H rise time for standard I/O port pins (Port A, B or C) ⁽²⁾		19		28	
$t_{I\text{TEXT}}$	External interrupt pulse time		1			t_{CPU}

- Hysteresis voltage between Schmitt trigger switching levels. Based on characterization results, not tested.
- Guaranteed by design, not tested in production.

Table 10. LED pins characteristics

Symbol	Parameter	Conditions	Min	Typ	Max	Unit
I_{Lsink}	Low current	$V_{PAD} > V_{DD}-2.4$	2		4	mA
I_{Lsink}	High current	$V_{PAD} > V_{DD}-2.4$ for ROM	5	6	8.4	

4.3 Supply and reset characteristics

Table 11 characteristics are measured at $T = 0$ to $+70$ °C, $V_{DD} - V_{SS} = 5.5$ V unless otherwise specified.

Table 11. Low voltage detector and supervisor characteristics (LVDS)

Symbol	Parameter	Conditions	Min	Typ	Max	Unit
V_{IT+}	Reset release threshold (V_{DD} rising)			3.7	3.9	V
V_{IT-}	Reset generation threshold (V_{DD} falling)		3.3	3.5		V
V_{hys}	Hysteresis $V_{IT+} - V_{IT-}$ ⁽¹⁾			200		mV
V_{IPOR}	V_{DD} rise time rate ¹⁾		20			ms/V

1. Hysteresis voltage between Schmitt trigger switching levels. Based on characterization results, not tested.

4.4 Clock and timing characteristics

4.4.1 General timings

Table 12 characteristics are measured at $T = 0$ to $+70$ °C unless otherwise specified.

Table 12. General timings

Symbol	Parameter	Conditions	Min	Typ ⁽¹⁾	Max	Unit
$t_{c(INST)}$	Instruction cycle time		2	3	12	t_{CPU}
		$f_{CPU}=4$ MHz	500	750	3000	ns
$t_{v(IT)}$	Interrupt reaction time ⁽²⁾ $t_{v(IT)} = \Delta t_{c(INST)} + 10$ ⁽³⁾		10		22	t_{CPU}
		$f_{CPU}=4$ MHz	2.5		5.5	μ s

1. Data based on typical application software.
2. Time measured between interrupt event and interrupt vector fetch. $\Delta t_{c(INST)}$ is the number of t_{CPU} cycles needed to finish the current instruction execution.
3. Δt_{INST} is the number of t_{CPU} to finish the current instruction execution.

Table 13. External clock source

Symbol	Parameter	Conditions	Min	Typ	Max	Unit
V_{OSCINH}	OSCIN input pin high level voltage	see Figure 5	$0.7V_{DD}$		V_{DD}	V
V_{OSCINL}	OSCIN input pin low level voltage		V_{SS}		$0.3V_{DD}$	
$t_w(OSCINH)$ $t_w(OSCINL)$	OSCIN high or low time ⁽¹⁾		15			ns
$t_r(OSCIN)$ $t_f(OSCIN)$	OSCIN rise or fall time ⁽¹⁾				15	
I_L	OSCx Input leakage current	$V_{SS} \leq V_{IN} \leq V_{DD}$			± 1	μA

1. Data based on design simulation and/or technology characteristics, not tested in production.

Figure 5. Typical application with an external clock source

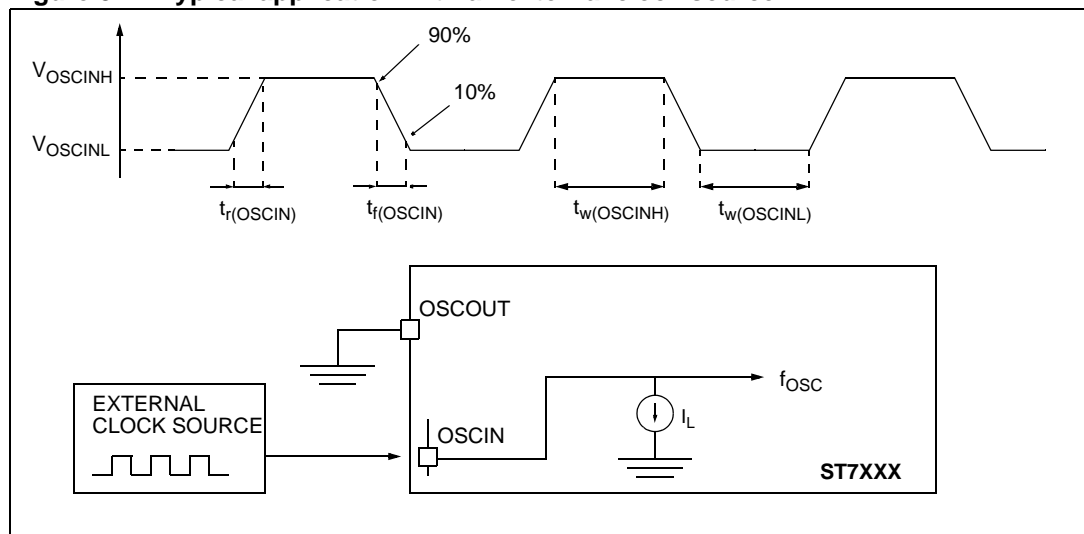

4.4.2 Crystal resonator oscillators

The ST7 internal clock is supplied with one Crystal resonator oscillator. All the information given in this paragraph are based on characterization results with specified typical external components. In the application, the resonator and the load capacitors have to be placed as close as possible to the oscillator pins in order to minimize output distortion and start-up stabilization time. Refer to the crystal resonator manufacturer for more details (frequency, package, accuracy...).

Table 14. Crystal resonator oscillator characteristics

Symbol	Parameter	Conditions		Min	Typ	Max	Unit
f_{OSC}	Oscillator Frequency ⁽¹⁾	MP: Medium power oscillator			4		MHz
R_F	Feedback resistor			90		150	k Ω
C_{L1} C_{L2}	Recommended load capacitances versus equivalent serial resistance of the crystal resonator (R_S)	See Table 16	(MP oscillator)	22		56	pF
i_2	OSCOUT driving current	$V_{DD}=5V, V_{IN}=V_{SS}$	(MP oscillator)	1.5		3.5	mA

- The oscillator selection can be optimized in terms of supply current using an high quality resonator with small R_S value. Refer to crystal resonator manufacturer for more details.

Table 15. Typical crystal resonator characteristics

Oscillator		Reference		Freq.	Characteristic ⁽¹⁾	CL1 [pF]	CL2 [pF]	t _{SU(osc)} [ms] ⁽²⁾
Crystal	MP	JAUCH	SS3-400-30-30/30	4 MHz	$\Delta f_{OSC}=[\pm 30ppm_{25^\circ C}, \pm 30ppm_{\Delta Ta}]$, Typ. $R_S=60\Omega$	33	33	7~10

- Resonator characteristics given by the crystal resonator manufacturer.
- t_{SU(OSC)} is the typical oscillator start-up time measured between $V_{DD}=2.8V$ and the fetch of the first instruction (with a quick V_{DD} ramp-up from 0 to 5 V (<50 μ s)).

Table 16. Recommended values for 4 MHz crystal resonator

Symbol	Min	Typ	Max	Unit
$R_{SMAX}^{(1)}$	20	25	70	Ω
C_{OSCIN}	56	47	22	pF
C_{OSCOUT}	56	47	22	

- R_{SMAX} is the equivalent serial resistor of the crystal (see crystal specification).

Figure 6. Typical application with a crystal resonator

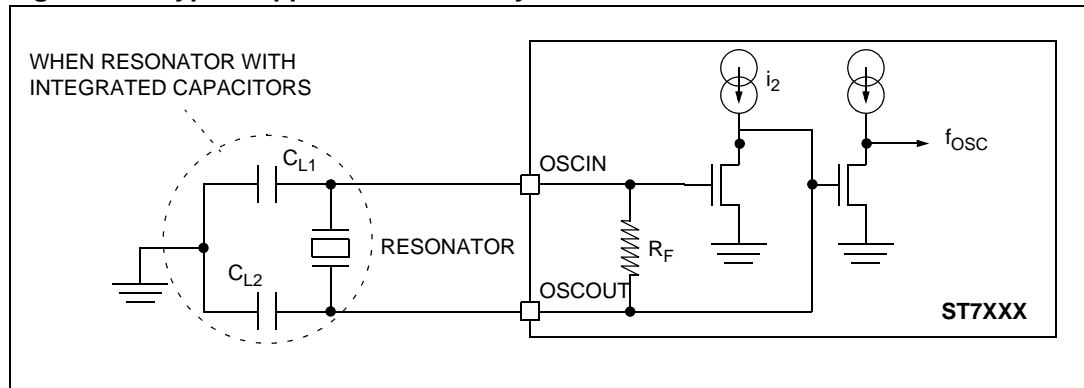

4.5 Memory characteristics

Subject to general operating conditions for V_{DD} , f_{OSC} , and T_A unless otherwise specified.

Table 17. RAM and hardware registers

Symbol	Parameter	Conditions	Min	Typ	Max	Unit
V_{RM}	Data retention mode ⁽¹⁾	Halt mode (or Reset)	2			V

1. Minimum V_{DD} supply voltage without losing data stored in RAM (in Halt mode or under Reset) or in hardware registers (only in Halt mode). Not tested in production.

4.6 Smartcard supply supervisor electrical characteristics

Table 18 characteristics are measured at $T_A = 0$ to $+70$ °C, 4.0 V $< V_{DD} - V_{SS} < 5.5$ V unless otherwise specified.

Table 18. Smartcard supply supervisor characteristics

Symbol	Parameter	Conditions	Min	Typ	Max	Unit
5 V regulator output (for IEC 7816-3 Class A Cards)						
V_{CRDVCC}	SmartCard power supply voltage		4.6	5.00	5.4	V
I_{SC}	SmartCard supply current				55	mA
I_{OVDET}	Current overload detection				120 ⁽¹⁾	mA
t_{IDET}	Detection time on current overload		170 ⁽¹⁾		1400 ⁽¹⁾	μ s
t_{OFF}	V_{CRDVCC} turn-off time	$C_{LOADmax} \leq 4.7\mu F$			750	μ s
t_{ON}	V_{CRDVCC} turn-on time	$C_{LOADmax} \leq 4.7\mu F$		150	500	μ s
V_{CRDVCC}	V_{CARD} above minimum supply voltage		4.52 ⁽¹⁾		4.76 ⁽¹⁾	V
I_{VDD}	V_{DD} supply current	(2)			100	mA

Table 18. Smartcard supply supervisor characteristics (continued)

Symbol	Parameter	Conditions	Min	Typ	Max	Unit
3 V regulator output (for IEC 7816-3 Class B Cards)						
V_{CRDVCC}	SmartCard power supply voltage		2.7		3.3	V
I_{SC}	SmartCard supply current				50	mA
I_{OVDET}	Current overload detection				100 ⁽¹⁾	mA
t_{IDET}	Detection time on current overload		170 ⁽¹⁾		1400 ⁽¹⁾	μ s
t_{OFF}	V_{CRDVCC} turn-off time	$C_{LOADmax} \leq 4.7\mu F$			750	μ s
t_{ON}	V_{CRDVCC} turn-on time	$C_{LOADmax} \leq 4.7\mu F$		150	500	μ s
1.8V regulator output (for IEC 7816-3 Class C Cards)						
V_{CRDVCC}	SmartCard power supply voltage		1.65		1.95	V
I_{SC}	SmartCard supply current				20	mA
I_{OVDET}	Current overload detection				100 ⁽¹⁾	mA
t_{IDET}	Detection time on current overload		170 ⁽¹⁾		1400 ⁽¹⁾	μ s
t_{OFF}	V_{CRDVCC} turn-off time	$C_{LOADmax} \leq 4.7\mu F$			750	μ s
t_{ON}	V_{CRDVCC} turn-on time	$C_{LOADmax} \leq 4.7\mu F$		150	500	μ s
Smartcard CLKPin						
V_{OL}	Output low level voltage	$I = -50\mu A$	-	-	0.4 ⁽³⁾	V
V_{OH}	Output high level voltage	$I = 50\mu A$	$V_{CRDVCC}-0.5^{(3)}$	-	-	V
T_{OHL}	Output high to low fall time ⁽¹⁾	$C_I = 30\text{ pF}$	-		20	ns
T_{OLH}	Output low to high rise time ⁽¹⁾	$C_I = 30\text{ pF}$	-		20	ns
F_{VAR}	Frequency variation ⁽¹⁾		-		1	%
F_{DUTY}	Duty cycle ⁽¹⁾		45		55	%
P_{OL}	Signal low perturbation ⁽¹⁾		-0.25		0.4	V
P_{OH}	Signal high perturbation ⁽¹⁾		$V_{CRDVCC}-0.5$		$V_{CRDVCC}+0.25$	V
I_{SGND}	Short-circuit to ground ⁽¹⁾			15		mA
Smartcard I/O Pin						
V_{IL}	Input low level voltage		-	-	0.5 ⁽³⁾	V
V_{IH}	Input high level voltage		$0.6V_{CRDVCC}^{(3)}$	-	-	V
V_{OL}	Output low Level Voltage	$I = -0.5\text{ mA}$	-	-	0.4 ⁽³⁾	V
V_{OH}	Output high level voltage	$I = 20\mu A$	$0.8V_{CRDVCC}^{(3)}$	-	$V_{CRDVCC}^{(3)}$	V
I_L	Input leakage current ⁽¹⁾	$V_{SS} < V_{IN} < V_{SC_PWR}$	-10	-	10	μ A
I_{RPU}	Pull-up equivalent resistance	$V_{IN} = V_{SS}$		24	30	k Ω

Table 18. Smartcard supply supervisor characteristics (continued)

Symbol	Parameter	Conditions	Min	Typ	Max	Unit
T _{OHL}	Output high to low fall time ⁽¹⁾	C _l = 30 pF	-		0.8	μs
T _{OLH}	Output low to high rise time ⁽¹⁾	C _l = 30 pF	-		0.8	μs
I _{SGND}	Short-circuit to ground ⁽¹⁾			15		mA
Smartcard RST C4 and C8 Pin						
V _{OL}	Output low Level Voltage	I = -0.5 mA	-	-	0.4 ⁽³⁾	V
V _{OH}	Output high level voltage	I = 20 μA	V _{CRDVCC} -0.5 ⁽³⁾	-	V _{CRDVCC} ⁽³⁾	V
T _{OHL}	Output high to low fall time ⁽¹⁾	C _l = 30 pF	-		0.8	μs
T _{OLH}	Output low to high rise time ⁽¹⁾	C _l = 30 pF	-		0.8	μs
I _{SGND}	Short-circuit to ground ⁽¹⁾			15		mA

1. Guaranteed by design.
2. V_{DD} = 4.75 V, Card consumption = 55mA, CRDCLK frequency = 4MHz, LED with a 3mA current, USB in reception mode and CPU in WFI mode.
3. Data based on characterization results, not tested in production.

4.7 EMC characteristics

Susceptibility tests are performed on a sample basis during product characterization.

4.7.1 Functional EMS (electromagnetic susceptibility)

Based on a simple running application on the product (toggling 2 LEDs through I/O ports), the product is stressed by two electromagnetic events until a failure occurs (indicated by the LEDs).

- **ESD**: electrostatic discharge (positive and negative) is applied on all pins of the device until a functional disturbance occurs. This test conforms with the IEC 1000-4-2 standard.
- **FTB**: a burst of fast transient voltage (positive and negative) is applied to V_{DD} and V_{SS} through a 100 pF capacitor, until a functional disturbance occurs. This test conforms with the IEC 1000-4-4 standard.

A device reset allows normal operations to be resumed. The test results are given in the table below based on the EMS levels and classes defined in application note AN1709.

Designing hardened software to avoid noise problems

EMC characterization and optimization are performed at component level with a typical application environment and simplified MCU software. It should be noted that good EMC performance is highly dependent on the user application and the software in particular.

Therefore it is recommended that the user applies EMC software optimization and prequalification tests in relation with the EMC level requested for his application.

Software recommendations

The software flowchart must include the management of runaway conditions such as:

- Corrupted program counter
- Unexpected reset
- Critical Data corruption (control registers...)

Prequalification trials

Most of the common failures (unexpected reset and program counter corruption) can be reproduced by manually forcing a low state on the RESET pin or the Oscillator pins for 1 second.

To complete these trials, ESD stress can be applied directly on the device, over the range of specification values. When unexpected behavior is detected, the software can be hardened to prevent unrecoverable errors occurring (see application note AN1015).

Table 19. EMS characteristics

Symbol	Parameter	Conditions	Level/Class
V _{FESD}	Voltage limits to be applied on any I/O pin to induce a functional disturbance	V _{DD} =5 V, T _A =+25 °C, f _{OSC} =8 MHz conforms to IEC 1000-4-2	2B
V _{FFTB}	Fast transient voltage burst limits to be applied through 100 pF on V _{DD} and V _{DD} pins to induce a functional disturbance	V _{DD} =5 V, T _A =+25 °C, f _{OSC} =8 MHz conforms to IEC 1000-4-4	4B

4.7.2 Electromagnetic interference (EMI)

Based on a simple application running on the product (toggling 2 LEDs through the I/O ports), the product is monitored in terms of emission. This emission test is in line with the norm SAE J 1752/3 which specifies the board and the loading of each pin.

Table 20. EMI characteristics

Symbol	Parameter	Conditions	Monitored frequency band	Max vs. [f _{osc} /f _{CPU}] ⁽¹⁾		Unit
				4/8 MHz	4/4 MHz	
S _{EMI}	Peak level	V _{DD} =5 V, T _A =+25 °C, conforming to SAE J 1752/3	0.1 MHz to 30 MHz	19	18	dBμV
			30 MHz to 130 MHz	32	27	
			130 MHz to 1 GHz	31	26	
			SAE EMI Level	4	3.5	-

1. Data based on characterization results, not tested in production.

4.7.3 Absolute maximum ratings (electrical sensitivity)

Based on three different tests (ESD, LU and DLU) using specific measurement methods, the product is stressed in order to determine its performance in terms of electrical sensitivity. For more details, refer to the application note AN1181.

Electrostatic discharge (ESD)

Electrostatic discharges (a positive then a negative pulse separated by 1 second) are applied to the pins of each sample according to each pin combination. The sample size depends on the number of supply pins in the device (3 parts*(n+1) supply pin). The Human Body Model is simulated. This test conforms to the JESD22-A114A standard.

Table 21. Absolute maximum ratings

Symbol	Ratings	Conditions	Maximum value ⁽¹⁾	Unit
$V_{ESD(HBM)}$	Electrostatic discharge voltage (Human Body Model)	$T_A=+25\text{ °C}$	2000	V

1. Data based on characterization results, not tested in production.

Static and dynamic latch-up

- **LU:** 3 complementary static tests are required on 10 parts to assess the latch-up performance. A supply overvoltage (applied to each power supply pin) and a current injection (applied to each input, output and configurable I/O pin) are performed on each sample. This test conforms to the EIA/JESD 78 IC latch-up standard. For more details, refer to the application note AN1181.
- **DLU:** Electrostatic discharges (one positive then one negative test) are applied to each pin of 3 samples when the micro is running to assess the latch-up performance in dynamic mode. Power supplies are set to the typical values, the oscillator is connected as near as possible to the pins of the micro and the component is put in reset mode. This test conforms to the IEC1000-4-2 and SAEJ1752/3 standards. For more details, refer to the application note AN1181.

Table 22. Electrical sensitivities

Symbol	Parameter	Conditions	Class ⁽¹⁾
LU	Static latch-up class	$T_A=+25\text{ °C}$	A
DLU	Dynamic latch-up class	$V_{DD}=5.5\text{ V}$, $f_{OSC}=4\text{ MHz}$, $T_A=+25\text{ °C}$	A

1. Class description: A Class is an STMicroelectronics internal specification. All its limits are higher than the JEDEC specifications, that means when a device belongs to Class A it exceeds the JEDEC standard. B Class strictly covers all the JEDEC criteria (international standard).

4.8 Communication interface characteristics

Table 23. USB DC electrical characteristics⁽¹⁾

Parameter	Symbol	Conditions	Min.	Max.	Unit
Input Levels					
Differential input sensitivity	VDI	I(D+, D-)	0.2		V
Differential common mode range	VCM	Includes VDI range	0.8	2.5	V
Single ended receiver threshold	VSE		1.3	2.0	V
Output levels					
Static output low	VOL	RL of 1.5 kΩ to 3.6 V		0.3	V
Static Output high	VOH	RL of 15 kΩ to V _{SS}	2.8	3.6	V
USBVCC: voltage level	USBV	V _{DD} =5 V	3.00	3.60	V

1. RL is the load connected on the USB drivers. All the voltages are measured from the local ground potential.

Figure 7. USB data signal rise and fall time

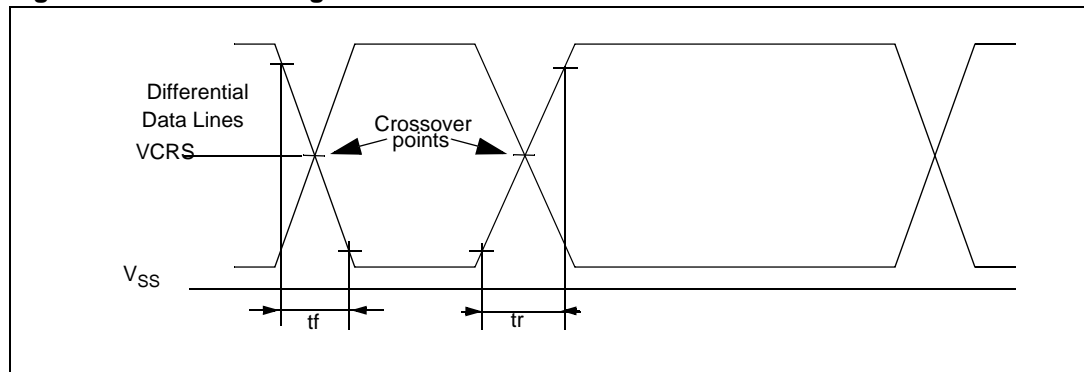

Table 24. USB full speed electrical characteristics

Parameter	Symbol	Conditions	Min	Max	Unit
Driver characteristics:					
Rise time	t _r	CL = 50 pF ⁽¹⁾	4	20	ns
Fall time	t _f	CL = 50 pF ⁽¹⁾	4	20	ns
Rise/ fall time matching	t _{rfm}	t _r /t _f	90	110	%
Output signal crossover Voltage	VCRS		1.3	2.0	V

1. Measured from 10% to 90% of the data signal. For more detailed informations, please refer to Chapter 7 (Electrical) of the USB specification (version 1.1).

5 Package characteristics

5.1 Package mechanical data

Figure 8. 24-lead very thin fine pitch quad flat no-lead 5x5 mm 0.65 mm pitch, package outline

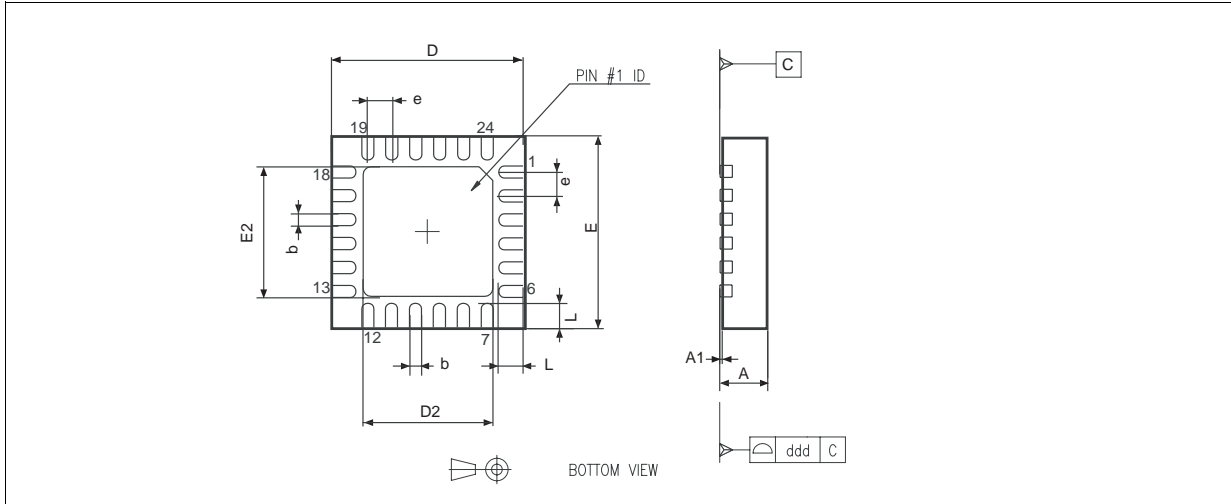

Table 25. 24-lead very thin fine pitch quad flat no-lead 5x5mm,0.65mm pitch, mechanical data

Dim.	mm			inches ⁽¹⁾		
	Min	Typ	Max	Min	Typ	Max
A	0.80	0.90	1.00	0.031	0.035	0.039
A1		0.02	0.05		0.001	0.002
b	0.25	0.30	0.35	0.010	0.012	0.014
D		5.00			0.197	
D2	3.50	3.60	3.70	0.138	0.142	0.146
E		5.00			0.197	
E2	3.50	3.60	3.70	0.138	0.142	0.146
e		0.65			0.026	
L	0.35	0.45	0.55	0.014	0.018	0.022
ddd		0.08			0.003	
Number of pins						
N	24					

1. Values in inches are converted from mm and rounded to 3 decimal digits.

Figure 9. 24-pin plastic small outline package- 300-mil width, package outline

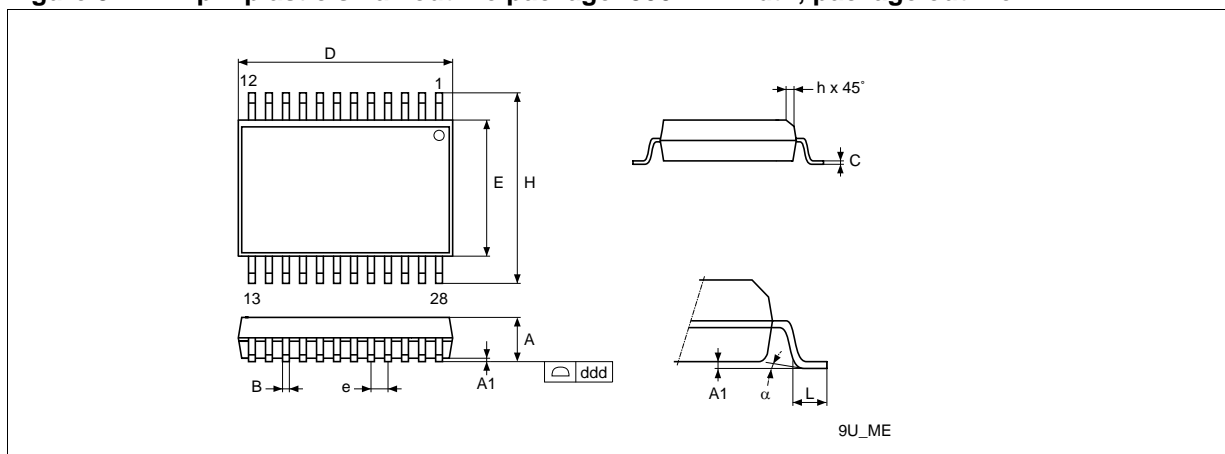

Table 26. 24-pin plastic small outline package- 300-mil width, mechanical data

Dim.	mm			inches		
	Min	Typ	Max	Min	Typ	Max
A	2.35		2.65	0.093		0.104
A1	0.10		0.30	0.004		0.012
B	0.33		0.51	0.013		0.020
C	0.23		0.32	0.009		0.020
D	15.20		15.60	0.599		0.619
E	7.40		7.60	0.291		0.299
e		1.27			0.050	
H	10.00		10.65	0.394		0.419
h	0.25		0.75	0.010		0.030
α	0°		8°	0°		8°
L	0.40		1.27	0.016		0.050
ddd			0.10			0.004
Number of pins						
N	24					

6 Revision history

Table 27. Document revision history

Date	Revision	Changes
01-Aug-06	0.1	Initial release
10-May-2007	1	Root part number changed from ST7GEM to ST7GEME4.
21-Sep-2007	2	<p>Document reformatted.</p> <p>Modified Figure 1 title.</p> <p>USB host interface replaced by USB interface in Section 1: Introduction and Table 3: Technical features.</p> <p>Updated Figure 9: 24-pin plastic small outline package- 300-mil width, package outline. ddd tolerance and maximum values in inches added in Table 26: 24-pin plastic small outline package- 300-mil width, mechanical data.</p> <p>QFN24 package renamed VFQFPN24. Figure 8: 24-lead very thin fine pitch quad flat no-lead 5x5 mm 0.65 mm pitch, package outline updated to remove A2 and A3 dimensions.</p>

Please Read Carefully:

Information in this document is provided solely in connection with ST products. STMicroelectronics NV and its subsidiaries ("ST") reserve the right to make changes, corrections, modifications or improvements, to this document, and the products and services described herein at any time, without notice.

All ST products are sold pursuant to ST's terms and conditions of sale.

Purchasers are solely responsible for the choice, selection and use of the ST products and services described herein, and ST assumes no liability whatsoever relating to the choice, selection or use of the ST products and services described herein.

No license, express or implied, by estoppel or otherwise, to any intellectual property rights is granted under this document. If any part of this document refers to any third party products or services it shall not be deemed a license grant by ST for the use of such third party products or services, or any intellectual property contained therein or considered as a warranty covering the use in any manner whatsoever of such third party products or services or any intellectual property contained therein.

UNLESS OTHERWISE SET FORTH IN ST'S TERMS AND CONDITIONS OF SALE ST DISCLAIMS ANY EXPRESS OR IMPLIED WARRANTY WITH RESPECT TO THE USE AND/OR SALE OF ST PRODUCTS INCLUDING WITHOUT LIMITATION IMPLIED WARRANTIES OF MERCHANTABILITY, FITNESS FOR A PARTICULAR PURPOSE (AND THEIR EQUIVALENTS UNDER THE LAWS OF ANY JURISDICTION), OR INFRINGEMENT OF ANY PATENT, COPYRIGHT OR OTHER INTELLECTUAL PROPERTY RIGHT.

UNLESS EXPRESSLY APPROVED IN WRITING BY AN AUTHORIZED ST REPRESENTATIVE, ST PRODUCTS ARE NOT RECOMMENDED, AUTHORIZED OR WARRANTED FOR USE IN MILITARY, AIR CRAFT, SPACE, LIFE SAVING, OR LIFE SUSTAINING APPLICATIONS, NOR IN PRODUCTS OR SYSTEMS WHERE FAILURE OR MALFUNCTION MAY RESULT IN PERSONAL INJURY, DEATH, OR SEVERE PROPERTY OR ENVIRONMENTAL DAMAGE. ST PRODUCTS WHICH ARE NOT SPECIFIED AS "AUTOMOTIVE GRADE" MAY ONLY BE USED IN AUTOMOTIVE APPLICATIONS AT USER'S OWN RISK.

Resale of ST products with provisions different from the statements and/or technical features set forth in this document shall immediately void any warranty granted by ST for the ST product or service described herein and shall not create or extend in any manner whatsoever, any liability of ST.

ST and the ST logo are trademarks or registered trademarks of ST in various countries.

Information in this document supersedes and replaces all information previously supplied.

The ST logo is a registered trademark of STMicroelectronics. All other names are the property of their respective owners.

© 2007 STMicroelectronics - All rights reserved

STMicroelectronics group of companies

Australia - Belgium - Brazil - Canada - China - Czech Republic - Finland - France - Germany - Hong Kong - India - Israel - Italy - Japan - Malaysia - Malta - Morocco - Singapore - Spain - Sweden - Switzerland - United Kingdom - United States of America

www.st.com