



ST72344xx, ST72345xx

8-bit MCU with up to 16 Kbytes Flash memory, 10-bit ADC,
two 16-bit timers, two I2C, SPI, SCI

Datasheet –production data

Features

- Memories
 - up to 16 Kbytes Program memory: single voltage extended Flash (XFlash) with read-out and write protection, in-circuit and in-application programming (ICP and IAP). 10,000 write/erase cycles guaranteed, data retention: 20 years at 55 °C.
 - up to 1 Kbyte RAM
 - 256 bytes data EEPROM with readout protection. 300,000 write/erase cycles guaranteed, data retention: 20 years at 55 °C.
- Clock, reset and supply management
 - Power on / power off safe reset with 3 programmable threshold levels (LVD)
 - Auxiliary voltage detector (AVD)
 - Clock sources: crystal/ceramic resonator oscillators, high-accuracy internal RC oscillator or external clock
 - PLL for 4x or 8x frequency multiplication
 - 5 power-saving modes: Slow, Wait, Halt, Auto-wakeup from Halt and Active-halt
 - Clock output capability (f_{CPU})
- Interrupt management
 - Nested interrupt controller
 - 10 interrupt vectors plus TRAP and RESET
 - 9 external interrupt lines on 4 vectors
- Up to 34 I/O ports
 - up to 34 multifunctional bidirectional I/O lines
 - up to 12 high sink outputs (10 on 32-pin devices)
- 4 timers
 - Configurable window watchdog timer
 - Real-time base
 - 16-bit timer A with: 1 input capture, 1 output compare, external clock input, PWM and pulse generator modes

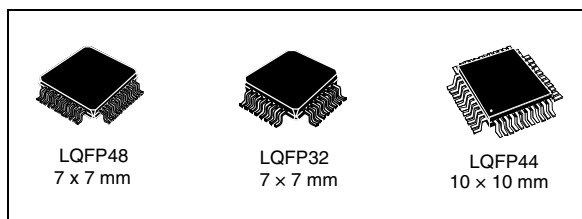

- 16-bit timer B with: 2 input captures, 2 output compares, PWM and pulse generator modes
- 3 communication interfaces
 - I²C multimaster / slave
 - I²C slave 3 addresses, no stretch, with DMA access and byte pair coherency on I²C read
 - SCI asynchronous serial interface (LIN compatible)
 - SPI synchronous serial interface
- 1 analog peripheral
 - 10-bit ADC with 12 input channels (8 on 32-pin devices)
- Instruction set
 - 8-bit data manipulation
 - 63 basic instructions with illegal opcode detection
 - 17 main addressing modes
 - 8 x 8 unsigned multiply instruction
- Development tools
 - Full hardware/software development package
 - On-chip debug module

Table 1. Device summary

References	Part numbers
ST72344xx	ST72344K2, ST72344K4, ST72344S2, ST72344S4
ST72345xx	ST72345C4

Contents

1	Description	15
2	Pin description	17
3	Register and memory map	23
4	Flash program memory	27
4.1	Introduction	27
4.2	Main features	27
4.3	Programming modes	27
4.3.1	In-circuit programming (ICP)	28
4.3.2	In-application programming (IAP)	28
4.4	ICC interface	28
4.5	Memory protection	29
4.5.1	Readout protection	29
4.5.2	Flash write/erase protection	30
4.6	Register description	30
4.6.1	Flash control/status register (FCSR)	30
5	Data EEPROM	31
5.1	Introduction	31
5.2	Main features	31
5.3	Memory access	31
5.4	Power saving modes	33
5.4.1	Wait mode	33
5.4.2	Active-halt mode	33
5.4.3	Halt mode	33
5.5	Access error handling	33
5.6	Data EEPROM readout protection	34
5.7	Register description	35
5.7.1	EEPROM control/status register (EECSR)	35
6	Central processing unit	36

6.1	Introduction	36
6.2	Main features	36
6.3	CPU registers	36
6.3.1	Condition code register (CC)	37
6.3.2	Stack pointer (SP)	39
7	Supply, reset and clock management	41
7.1	Main features	41
7.2	Phase locked loop	42
7.3	Multioscillator (MO)	43
7.3.1	External clock source	43
7.3.2	Crystal/ceramic oscillators	43
7.3.3	Internal RC oscillator	45
7.4	Register description	45
7.4.1	RC control register (RCCRH)	45
7.4.2	RC control register (RCCRL)	46
7.5	Reset sequence manager (RSM)	46
7.5.1	Introduction	46
7.5.2	Asynchronous external RESET pin	47
7.5.3	External power-on reset	47
7.5.4	Internal low-voltage detector (LVD) reset	48
7.5.5	Internal watchdog reset	48
7.6	System integrity management (SI)	48
7.6.1	Low-voltage detector (LVD)	49
7.6.2	Auxiliary-voltage detector (AVD)	49
7.6.3	Low-power modes	50
7.6.4	Interrupts	50
7.6.5	Register description	51
8	Interrupts	53
8.1	Introduction	53
8.2	Masking and processing flow	53
8.3	Interrupts and low-power modes	56
8.4	Concurrent & nested management	56
8.5	Interrupt register description	57
8.5.1	CPU CC register interrupt bits	57

- 8.5.2 Interrupt software priority registers (ISPRX) 58
- 8.6 External interrupts 60
 - 8.6.1 I/O port interrupt sensitivity 60
- 8.7 External interrupt control register (EICR) 61

- 9 Power-saving modes 64**
 - 9.1 Introduction 64
 - 9.2 Slow mode 65
 - 9.3 Wait mode 65
 - 9.4 Halt mode 66
 - 9.5 Active-halt mode 68
 - 9.6 Auto-wakeup from Halt mode 70
 - 9.7 Register description 72
 - 9.7.1 AWUFH control/status register (AWUCSR) 72
 - 9.7.2 AWUFH prescaler register (AWUPR) 73

- 10 I/O ports 74**
 - 10.1 Introduction 74
 - 10.2 Functional description 74
 - 10.2.1 Input modes 74
 - 10.2.2 Output modes 75
 - 10.2.3 Alternate functions 75
 - 10.3 I/O port implementation 78
 - 10.4 Low-power modes 78
 - 10.5 Interrupts 78
 - 10.5.1 I/O port implementation 79

- 11 On-chip peripherals 82**
 - 11.1 Window watchdog (WWDG) 82
 - 11.1.1 Introduction 82
 - 11.1.2 Main features 82
 - 11.1.3 Functional description 82
 - 11.1.4 Using Halt mode with the WDG 84
 - 11.1.5 How to program the watchdog timeout 84
 - 11.1.6 Low-power modes 86
 - 11.1.7 Hardware watchdog option 87

11.1.8	Using Halt mode with the WDG (WDGHALT option)	87
11.1.9	Interrupts	87
11.1.10	Register description	87
11.2	Main clock controller with real-time clock and beeper (MCC/RTC)	88
11.2.1	Programmable CPU clock prescaler	88
11.2.2	Clock-out capability	88
11.2.3	Real-time clock timer (RTC)	88
11.2.4	Beeper	88
11.2.5	Low-power modes	89
11.2.6	Interrupts	89
11.2.7	Register description	90
11.3	16-bit timer	93
11.3.1	Introduction	93
11.3.2	Main features	93
11.3.3	Functional description	94
11.3.4	Low-power modes	107
11.3.5	Interrupts	107
11.3.6	Summary of timer modes	108
11.3.7	Register description	108
11.4	Serial peripheral interface (SPI)	115
11.4.1	Introduction	115
11.4.2	Main features	115
11.4.3	General description	115
11.4.4	Clock phase and clock polarity	120
11.4.5	Error flags	121
11.4.6	Low-power modes	124
11.4.7	Interrupts	125
11.4.8	Register description	125
11.5	SCI serial communication interface	129
11.5.1	Introduction	129
11.5.2	Main features	129
11.5.3	General description	129
11.5.4	Functional description	132
11.5.5	Low-power modes	141
11.5.6	Interrupts	142
11.5.7	Register description	142

11.6	I2C bus interface (I2C)	150
11.6.1	Introduction	150
11.6.2	Main features	150
11.6.3	General description	150
11.6.4	Functional description	152
11.6.5	Low-power modes	158
11.6.6	Interrupts	158
11.6.7	Register description	159
11.7	I2C triple slave interface with DMA (I2C3S)	167
11.7.1	Introduction	167
11.7.2	Main features	167
11.7.3	General description	168
11.7.4	Functional description	169
11.7.5	Address handling	172
11.7.6	Low-power modes	176
11.7.7	Interrupt generation	177
11.7.8	Register description	178
11.8	10-bit A/D converter (ADC)	185
11.8.1	Introduction	185
11.8.2	Main features	185
11.8.3	Functional description	186
11.8.4	Low-power modes	187
11.8.5	Interrupts	187
11.8.6	Register description	187
12	Instruction set	190
12.1	ST7 addressing modes	190
12.1.1	Inherent	191
12.1.2	Immediate	192
12.1.3	Direct	192
12.1.4	Indexed (No Offset, Short, Long)	192
12.1.5	Indirect (Short, Long)	193
12.1.6	Indirect Indexed (Short, Long)	193
12.1.7	Relative Mode (direct, indirect)	194
12.2	Instruction groups	195
12.2.1	Illegal opcode reset	196

13	Electrical characteristics	199
13.1	Parameter conditions	199
13.1.1	Minimum and maximum values	199
13.1.2	Typical values	199
13.1.3	Typical curves	199
13.1.4	Loading capacitor	199
13.1.5	Pin input voltage	200
13.2	Absolute maximum ratings	200
13.3	Operating conditions	202
13.4	Internal RC oscillator characteristics	204
13.5	Supply current characteristics	205
13.6	Clock and timing characteristics	209
13.6.1	Crystal and ceramic resonator oscillators	210
13.7	Memory characteristics	212
13.8	EMC characteristics	213
13.8.1	Functional EMS (electromagnetic susceptibility)	213
13.8.2	EMI (electromagnetic interference)	214
13.8.3	Absolute maximum ratings (electrical sensitivity)	214
13.9	I/O port pin characteristics	215
13.10	Control pin characteristics	222
13.10.1	Asynchronous RESET pin	222
13.11	Communication interface characteristics	224
13.11.1	I ² C and I ² C3SNS interfaces	224
13.12	10-bit ADC characteristics	225
14	Package characteristics	227
14.1	ECOPACK	227
14.2	Package mechanical data	227
15	Device configuration and ordering information	232
15.1	Option bytes	232
15.1.1	Option byte 0	232
15.1.2	Option byte 1	233
15.1.3	Option byte 2	234
15.1.4	Option byte 3	235

15.2	Device ordering information	236
15.3	Development tools	236
15.3.1	Starter kits	236
15.3.2	Development and debugging tools	237
15.3.3	Programming tools	237
15.3.4	Order codes for ST72F34x development tools	238
16	Known limitations	239
16.1	External interrupt missed	239
16.1.1	Workaround	239
16.1.2	Unexpected reset fetch	241
16.2	Clearing active interrupts outside interrupt routine	241
16.3	16-bit timer PWM mode	242
16.4	TIMD set simultaneously with OC interrupt	242
16.4.1	Impact on the application	242
16.4.2	Workaround	242
16.5	SCI wrong break duration	242
16.5.1	Description	242
16.5.2	Occurrence	243
16.5.3	Workaround	243
16.6	Random read operations not supported with the standard I ² C	243
16.6.1	Description	243
16.6.2	Occurrence	243
16.6.3	Workaround	243
16.7	Programming of EEPROM data	243
16.7.1	Description	243
16.7.2	Impact on application	243
16.7.3	Workaround	244
17	Revision history	245

List of tables

Table 1.	Device summary	1
Table 2.	ST72344xx and ST72345xx features	16
Table 3.	Device pin description	20
Table 4.	Hardware register map	24
Table 5.	Data EEPROM register map and reset values	35
Table 6.	Interrupt software priority	38
Table 7.	PLL configurations	42
Table 8.	ST7 clock sources	44
Table 9.	Calibration values	45
Table 10.	Low-power mode description	50
Table 11.	Interrupt event.	50
Table 12.	LVDRF and WDGRF description	51
Table 13.	Interrupt software priority levels	54
Table 14.	Interrupt software priority	57
Table 15.	Interrupt vector addresses	58
Table 16.	Dedicated interrupt instruction set	58
Table 17.	Interrupt mapping	59
Table 18.	External interrupt sensitivity (ei2)	61
Table 19.	External interrupt sensitivity (ei3)	61
Table 20.	External interrupt sensitivity (ei0)	62
Table 21.	External interrupt sensitivity (ei1)	62
Table 22.	Nested interrupts register map and reset values	63
Table 23.	Power saving mode	68
Table 24.	AWUPR dividing factor	73
Table 25.	AWU register map and reset values	73
Table 26.	Output modes	75
Table 27.	I/O Port mode options	76
Table 28.	I/O port configurations	77
Table 29.	Description	78
Table 30.	Description of interrupt events	78
Table 31.	I/O port register configurations (standard ports)	79
Table 32.	I/O port register configurations (interrupt ports with pull-up)	79
Table 33.	I/O port register configurations (interrupt ports without pull-up)	79
Table 34.	I/O port register configurations (true open drain ports)	79
Table 35.	Port configuration	80
Table 36.	I/O port register map and reset values	80
Table 37.	Descriptions	86
Table 38.	Watchdog timer register map and reset values	88
Table 39.	Mode description	89
Table 40.	Interrupt event.	89
Table 41.	CPU clock prescaler selection	90
Table 42.	Time base control	91
Table 43.	Beep control	92
Table 44.	Main clock controller register map and reset values	92
Table 45.	ICiR register	98
Table 46.	OCiR register	100
Table 47.	Low-power mode description	107
Table 48.	Interrupt events	107

Table 49.	Timer modes	108
Table 50.	Clock control bits	110
Table 51.	16-bit timer register map and reset values	114
Table 52.	Description	124
Table 53.	Interrupt events	125
Table 54.	SPI master mode SCK frequency	126
Table 55.	SPI register map and reset values	128
Table 56.	Frame formats	139
Table 57.	Mode description	141
Table 58.	Interrupt events	142
Table 59.	SCP[1:0] configuration	147
Table 60.	SCT[2:0] configuration	147
Table 61.	SCR[2:0] configuration	147
Table 62.	Baud rate selection	148
Table 63.	SCI register map and reset values	149
Table 64.	Mode description	158
Table 65.	Interrupt events	158
Table 66.	FR[1:0] configuration	166
Table 67.	I2C register map and reset values	166
Table 68.	Mode description	176
Table 69.	Interrupt events	177
Table 70.	PL configuration	178
Table 71.	I2C3S register map	183
Table 72.	Mode description	187
Table 73.	Channel selection	188
Table 74.	ADC register map and reset values	189
Table 75.	Addressing mode groups	190
Table 76.	ST7 addressing mode overview	190
Table 77.	Inherent instructions	191
Table 78.	Immediate instructions	192
Table 79.	Instructions supporting direct, indexed, indirect and indirect indexed addressing modes	194
Table 80.	Short instructions	194
Table 81.	Relative direct/indirect instructions	194
Table 82.	Main instruction groups	195
Table 83.	Illegal opcode detection	196
Table 84.	Voltage characteristics	200
Table 85.	Current characteristics	201
Table 86.	Thermal characteristics	201
Table 87.	General operating conditions	202
Table 88.	LVD thresholds	202
Table 89.	AVD thresholds	203
Table 90.	PLL characteristics	203
Table 91.	Internal RC oscillator and PLL	203
Table 92.	Internal RC oscillator characteristics	204
Table 93.	Supply current	205
Table 94.	On-chip peripherals	208
Table 95.	General timings	209
Table 96.	External clock source	209
Table 97.	Auto-wakeup from Halt oscillator (AWU) characteristics	210
Table 98.	Crystal/ceramic resonator oscillator characteristics	210
Table 99.	Recommended load capacitance vs. equivalent serial resistance of ceramic resonator	211

Table 100.	RAM and hardware registers	212
Table 101.	Flash program memory	212
Table 102.	EEPROM data memory	212
Table 103.	EMS test results	213
Table 104.	EMI emissions	214
Table 105.	ESD absolute maximum ratings	214
Table 106.	Electrical sensitivities	215
Table 107.	General characteristics	215
Table 108.	Output driving current	216
Table 109.	Asynchronous RESET pin characteristics	222
Table 110.	I2C and I2C3SNS interfaces characteristics	224
Table 111.	SCL frequency table (multimaster I2C interface)	224
Table 112.	ADC accuracy	225
Table 113.	ADC characteristics	226
Table 114.	32-pin low profile quad flat package (7 x 7 mm) mechanical data	228
Table 115.	40-lead very thin fine pitch quad flat no-lead package mechanical data	229
Table 116.	44-pin low profile quad flat package mechanical data	230
Table 117.	48-pin low profile quad flat package mechanical data	231
Table 118.	Thermal characteristics	231
Table 119.	LVD threshold configuration	232
Table 120.	Size of sector 0	232
Table 121.	Selection of the resonator oscillator range	234
Table 122.	List of valid option combinations	234
Table 123.	Package selection	235
Table 124.	Option byte default values	235
Table 125.	Development tool order codes	238
Table 126.	Document revision history	245

List of figures

Figure 1.	General block diagram	15
Figure 2.	LQFP32 package pinout	17
Figure 3.	LQFP44 package pinout	18
Figure 4.	LQFP48 package pinout	19
Figure 5.	Memory map	23
Figure 6.	Typical ICC interface	29
Figure 7.	EEPROM block diagram	31
Figure 8.	Data EEPROM programming flowchart	32
Figure 9.	Data EEPROM write operation	33
Figure 10.	Data EEPROM programming cycle	34
Figure 11.	CPU registers	37
Figure 12.	Stack manipulation example	40
Figure 13.	Clock, reset and supply block diagram	41
Figure 14.	PLL output frequency timing diagram	42
Figure 15.	reset sequence phases	47
Figure 16.	Reset block diagram	47
Figure 17.	Reset sequences	48
Figure 18.	Low voltage detector vs. reset	49
Figure 19.	Using the AVD to monitor VDD	50
Figure 20.	Interrupt processing flowchart	54
Figure 21.	Priority decision process	54
Figure 22.	Concurrent interrupt management	56
Figure 23.	Nested interrupt management	57
Figure 24.	External interrupt control bits	60
Figure 25.	Power saving mode transitions	64
Figure 26.	Slow mode clock transitions	65
Figure 27.	Wait mode flowchart	66
Figure 28.	Halt timing overview	67
Figure 29.	Halt mode flowchart	67
Figure 30.	Active-halt timing overview	69
Figure 31.	Active-halt mode flowchart	69
Figure 32.	AWUFH mode block diagram	70
Figure 33.	AWUF Halt timing diagram	71
Figure 34.	AWUFH mode flowchart	71
Figure 35.	I/O port general block diagram	76
Figure 36.	Interrupt I/O port state transitions	78
Figure 37.	Watchdog block diagram	83
Figure 38.	Approximate timeout duration	84
Figure 39.	Exact timeout duration (t _{min} and t _{max})	85
Figure 40.	Window watchdog timing diagram	86
Figure 41.	Main clock controller (MCC/RTC) block diagram	89
Figure 42.	Timer block diagram	95
Figure 43.	16-bit read sequence (from either the counter register or the alternate counter register)	96
Figure 44.	Counter timing diagram, internal clock divided by 2	97
Figure 45.	Counter timing diagram, internal clock divided by 4	97
Figure 46.	Counter timing diagram, internal clock divided by 8	97
Figure 47.	Input capture block diagram	99

Figure 48.	Input capture timing diagram	99
Figure 49.	Output compare block diagram	101
Figure 50.	Output compare timing diagram, $f_{\text{TIMER}} = f_{\text{CPU}}/2$	102
Figure 51.	Output compare timing diagram, $f_{\text{TIMER}} = f_{\text{CPU}}/4$	102
Figure 52.	One-pulse mode cycle	103
Figure 53.	One-pulse mode timing example	104
Figure 54.	Pulse width modulation mode timing example	105
Figure 55.	Pulse width modulation cycle	106
Figure 56.	Serial peripheral interface block diagram	116
Figure 57.	Single master/ single slave application	117
Figure 58.	Generic SS timing diagram	118
Figure 59.	Hardware/software slave select management	118
Figure 60.	Data clock timing diagram	121
Figure 61.	Clearing the WCOL bit (write collision flag) software sequence	123
Figure 62.	Single master / multiple slave configuration	124
Figure 63.	SCI block diagram	131
Figure 64.	Word length programming	133
Figure 65.	SCI baud rate and extended prescaler block diagram	137
Figure 66.	Bit sampling in reception mode	141
Figure 67.	I2C bus protocol	151
Figure 68.	I2C interface block diagram	152
Figure 69.	Transfer sequencing	157
Figure 70.	Event flags and interrupt generation	158
Figure 71.	I2C3S interface block diagram	168
Figure 72.	I2C bus protocol	169
Figure 73.	16-bit word write operation flowchart	171
Figure 74.	16-bit word read operation flowchart	172
Figure 75.	Transfer sequencing	175
Figure 76.	Byte write	175
Figure 77.	Page write	175
Figure 78.	Current address read	175
Figure 79.	Random read (dummy write + restart + current address read)	175
Figure 80.	Random read (dummy write + stop + start + current address read)	176
Figure 81.	Sequential read	176
Figure 82.	Combined format for read	176
Figure 83.	Event flags and interrupt generation	177
Figure 84.	ADC block diagram	185
Figure 85.	Pin loading conditions	199
Figure 86.	Pin input voltage	200
Figure 87.	f_{CPU} maximum operating frequency versus V_{DD} supply voltage	202
Figure 88.	Typical RC frequency vs. RCCR	204
Figure 89.	Typical I_{DD} in Run vs. f_{CPU}	206
Figure 90.	Typical I_{DD} in Run at $f_{\text{CPU}} = 8$ MHz	206
Figure 91.	Typical I_{DD} in Slow vs. f_{CPU}	206
Figure 92.	Typical I_{DD} in Wait vs. f_{CPU}	207
Figure 93.	Typical I_{DD} in Wait at $f_{\text{CPU}} = 8$ MHz	207
Figure 94.	Typical I_{DD} in Slow-wait vs. f_{CPU}	207
Figure 95.	Typical I_{DD} vs. temp. at $V_{\text{DD}} = 5$ V and $f_{\text{CPU}} = 8$ MHz	208
Figure 96.	Typical application with an external clock source	209
Figure 97.	Typical application with a crystal or ceramic resonator	211
Figure 98.	Two typical applications with unused I/O pin	216
Figure 99.	Typical V_{OL} at $V_{\text{DD}} = 2.4$ V (std I/Os)	217

Figure 100. Typical V_{OL} at $V_{DD} = 3\text{ V}$ (std I/Os)	217
Figure 101. Typical V_{OL} at $V_{DD} = 5\text{ V}$ (std I/Os)	217
Figure 102. Typical V_{OL} at $V_{DD} = 2.4\text{ V}$ (high-sink I/Os)	218
Figure 103. Typical V_{OL} at $V_{DD} = 3\text{ V}$ (high-sink I/Os)	218
Figure 104. Typical V_{OL} at $V_{DD} = 5\text{ V}$ (high-sink I/Os)	218
Figure 105. Typical V_{OL} vs. V_{DD} (std I/Os, 2 mA)	219
Figure 106. Typical V_{OL} vs. V_{DD} (std I/Os, 6 mA)	219
Figure 107. Typical V_{OL} vs. V_{DD} (HS I/Os, $I_{IO} = 8\text{ mA}$)	219
Figure 108. Typical V_{OL} vs. V_{DD} (HS I/Os, $I_{IO} = 2\text{ mA}$)	220
Figure 109. Typical V_{OL} vs. V_{DD} (HS I/Os, $I_{IO} = 12\text{ mA}$)	220
Figure 110. Typical $V_{DD} - V_{OH}$ at $V_{DD} = 2.4\text{ V}$ (std I/Os)	220
Figure 111. Typical $V_{DD} - V_{OH}$ at $V_{DD} = 3\text{ V}$ (std I/Os)	221
Figure 112. Typical $V_{DD} - V_{OH}$ at $V_{DD} = 4\text{ V}$ (std)	221
Figure 113. Typical $V_{DD} - V_{OH}$ at $V_{DD} = 5\text{ V}$ (std)	221
Figure 114. Typical $V_{DD} - V_{OH}$ vs. V_{DD} (high sink)	222
Figure 115. $\overline{\text{RESET}}$ pin protection when LVD is enabled(1)(2)(3)(4)	223
Figure 116. $\overline{\text{RESET}}$ pin protection when LVD is disabled (1)	223
Figure 117. ADC accuracy characteristics	225
Figure 118. Typical A/D converter application	226
Figure 119. 32-pin low profile quad flat package (7 x 7 mm) outline	227
Figure 120. 40-lead very thin fine pitch quad flat no-lead package outline	228
Figure 121. 44-pin low profile quad flat package outline	229
Figure 122. 48-pin low profile quad flat package outline	230
Figure 123. ST7234x ordering information scheme	236

1 Description

The ST7234x devices are members of the ST7 microcontroller family. [Table 2](#) gives the available part numbers and details on the devices. All devices are based on a common industry-standard 8-bit core, featuring an enhanced instruction set.

They feature single-voltage Flash memory with byte-by-byte in-circuit programming (ICP) and in-application programming (IAP) capabilities.

Under software control, all devices can be placed in Wait, Slow, Auto-wakeup from Halt, Active-halt or Halt mode, reducing the power consumption when the application is in idle or stand-by state.

The enhanced instruction set and addressing modes of the ST7 offer both power and flexibility to software developers, enabling the design of highly efficient and compact application code. In addition to standard 8-bit data management, all ST7 microcontrollers feature true bit manipulation, 8x8 unsigned multiplication and indirect addressing modes.

The devices feature an on-chip debug module (DM) to support in-circuit debugging (ICD). For a description of the DM registers, refer to the ST7 ICC Protocol Reference Manual.

Figure 1. General block diagram

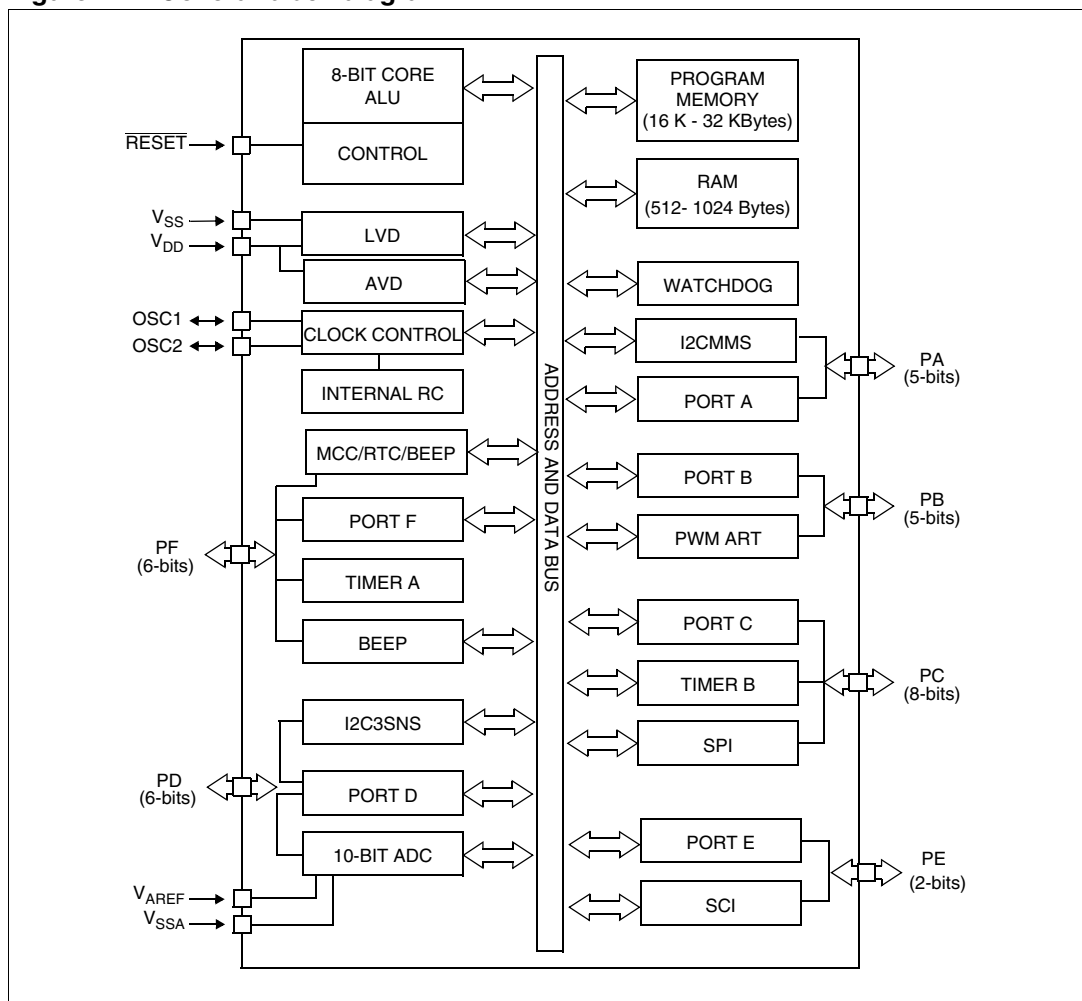

Table 2. ST72344xx and ST72345xx features

Features	ST72344K2, ST72344K4, ST72344S2, ST72344S4		ST72345C4
Program memory - bytes	8,000	16,000	16,000
RAM (stack) - bytes	512 bytes (256 bytes)	1 Kbyte (256 bytes)	1 Kbyte (256 bytes)
EEPROM data - bytes	256	256	256
Common peripherals	Window watchdog, 2 16-bit timers, SCI, SPI, I2CMMS		
Other peripherals	10-bit ADC		I2C3SNS, 10-bit ADC
CPU frequency	8 MHz @ 3.3 V to 5.5 V, 4 MHz @ 2.7 V to 5.5 V		
Temperature range	-40 °C to +85 °C		
Package	LQFP32 7x7, LQFP44 10x10		LQFP48 7x7

2 Pin description

Figure 2. LQFP32 package pinout

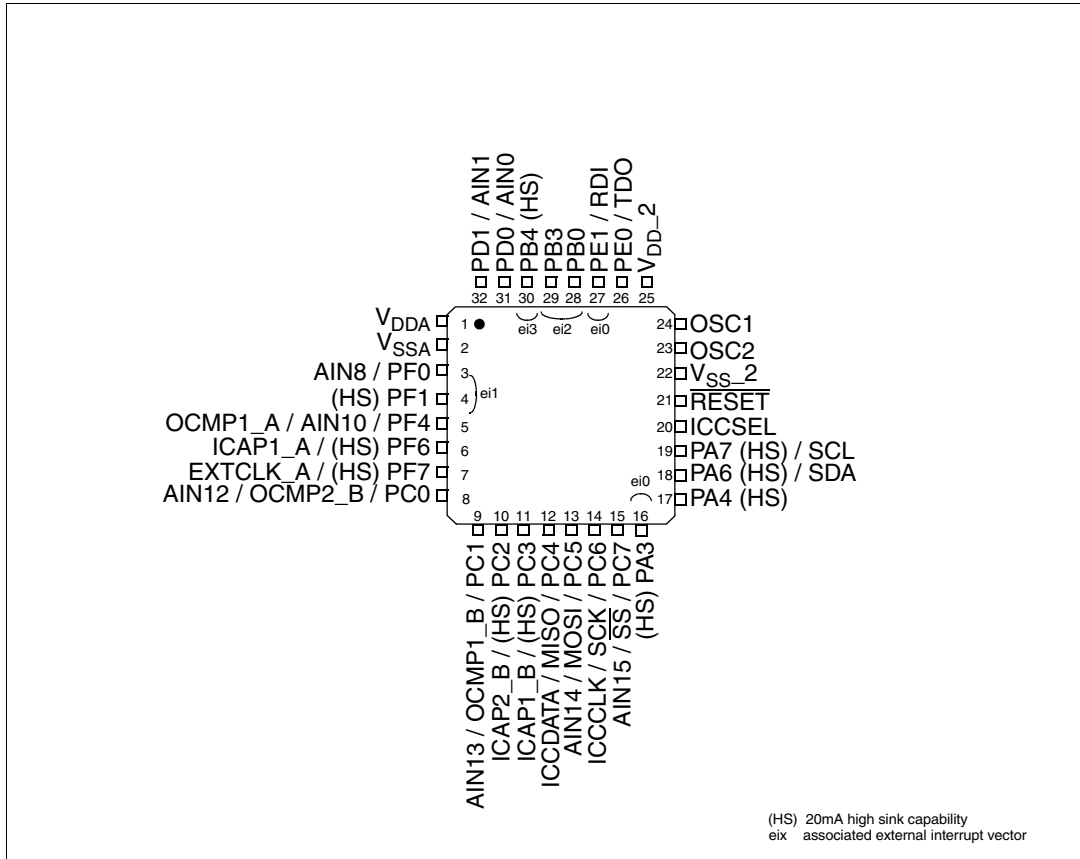

Figure 3. LQFP44 package pinout

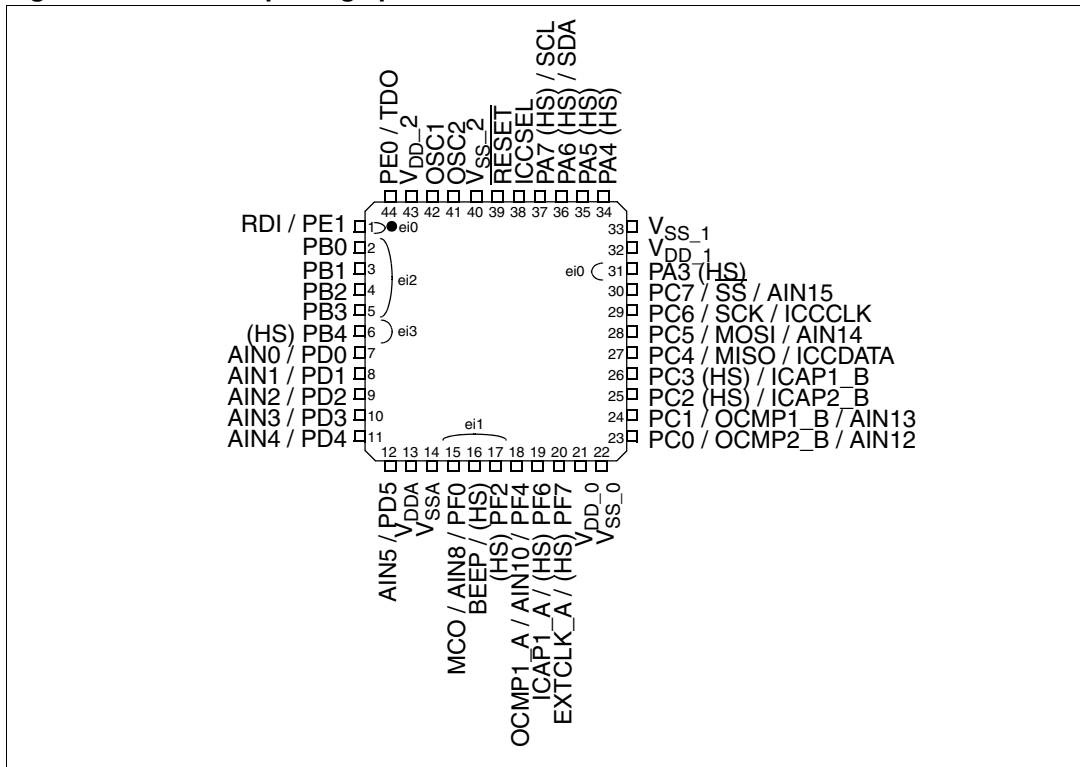
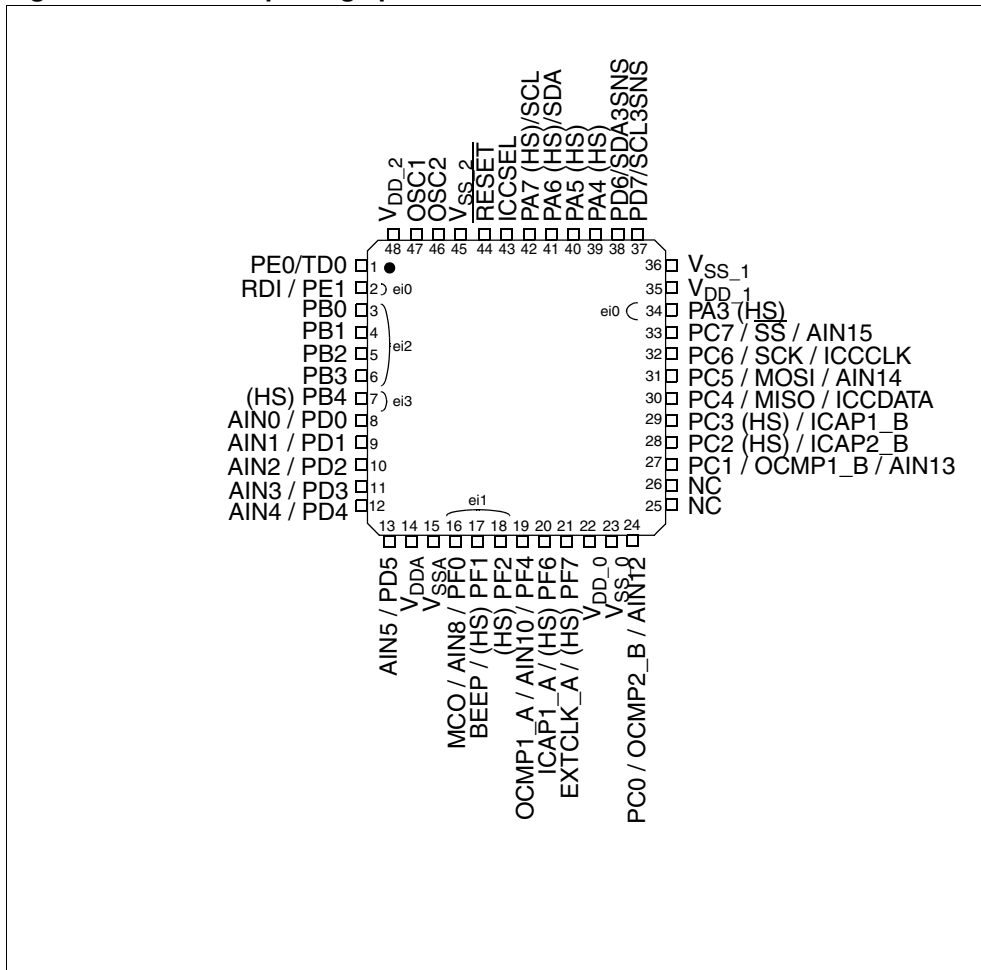

Figure 4. LQFP48 package pinout



Note: For external pin connection guidelines, refer to [Section 13: Electrical characteristics](#).

Legend / Abbreviations for Table 3:

Type: I = input, O = output, S = supply

Input level: A = Dedicated analog input

In/Output level: C_T= CMOS 0.3V_{DD}/0.7V_{DD} with input trigger

Output level: HS = 20 mA high sink (on N-buffer only)

Port and control configuration:

- Input: float = floating, wpu = weak pull-up, int = interrupt ¹⁾, ana = analog
- Output: OD = open drain ²⁾, PP = push-pull

The reset configuration of each pin is shown in bold. This configuration is valid as long as the device is in reset state.

On the chip, each I/O port may have up to 8 pads. Pads that are not bonded to external pins are set in input pull-up configuration after reset through the option byte Package selection. The configuration of these pads must be kept at reset state to avoid added current consumption.

Table 3. Device pin description

Pin n°			Pin name	Type	Level		Port						Main function (after reset)	Alternate function			
LQFP32	LQFP44	LQFP48			Input	Output	Input ⁽¹⁾				Output						
							float	wpu	int	ana	OD	PP					
1	13	14	V _{DDA} ⁽²⁾	S												Analog supply voltage	
2	14	15	V _{SSA} ⁽²⁾	S													Analog ground voltage
3	15	16	PF0/MCO/AIN8	I/O	C _T		X	ei1		X	X	X	Port F0	Main clock out (f _{OSC} /2)	ADC analog input 8		
4	16	17	PF1 (HS)/BEEP	I/O	C _T	HS	X	ei1			X	X	Port F1	Beep signal output			
-	17	18	PF2 (HS) ⁽³⁾	I/O	C _T	HS	X		ei1		X	X	Port F2				
5	18	19	PF4/OCMP1_A/AIN10	I/O	C _T		X	X		X	X	X	Port F4	Timer A output compare 1	ADC analog input 10		
6	19	20	PF6 (HS)/ICAP1_A	I/O	C _T	HS	X	X			X	X	Port F6	Timer A Input Capture 1			
7	20	21	PF7 (HS)/EXTCLK_A	I/O	C _T	HS	X	X			X	X	Port F7	Timer A external clock source			
-	21	22	V _{DD_0} ⁽²⁾	S									Digital main supply voltage				
-	22	23	V _{SS_0} ⁽²⁾	S									Digital ground voltage				
8	23	24	PC0/OCMP2_B/AIN12	I/O	C _T		X	X		X	X	X	Port C0	Timer B output compare 2	ADC analog input 12		
9	24	27	PC1/OCMP1_B/AIN13	I/O	C _T		X	X		X	X	X	Port C1	Timer B output compare 1	ADC analog input 13		

Table 3. Device pin description (continued)

Pin n°			Pin name	Type	Level		Port						Main function (after reset)	Alternate function	
LQFP32	LQFP44	LQFP48			Input	Output	Input (1)				Output				
							float	wpu	int	ana	OD	PP			
10	25	28	PC2 (HS)/ICAP2_B	I/O	C _T	HS	X	X			X	X	Port C2	Timer B input capture 2	
11	26	29	PC3 (HS)/ICAP1_B	I/O	C _T	HS	X	X			X	X	Port C3	Timer B input capture 1	
12	27	30	PC4/MISO/ICCDATA	I/O	C _T		X	X			X	X	Port C4	SPI Master In / Slave Out data ICC data input	
13	28	31	PC5/MOSI/AIN14	I/O	C _T		X	X		X	X	X	Port C5	SPI Master Out / Slave In data ADC analog input 14	
14	29	32	PC6/SCK/ICCCLK	I/O	C _T		X	X			X	X	Port C6	SPI serial clock ICC clock output	
15	30	33	PC7/ \overline{SS} /AIN15	I/O	C _T		X	X		X	X	X	Port C7	SPI slave select (active low) ADC analog input 15	
16	31	34	PA3 (HS)	I/O	C _T	HS	X			ei0		X	X	Port A3	
-	32	35	V _{DD_1} (2)	S											Digital main supply voltage
-	33	36	V _{SS_1} (2)	S											Digital ground voltage
-	-	37	PD7 (3)/ SCL3SNS	I/O	C _T	HS	X					T (4)		Port D7	I2C3SNS serial clock
-	-	38	PD6 (3)/ SDA3SNS	I/O	C _T	HS	X					T		Port D6	I2C3SNS serial data
17	34	39	PA4 (HS)	I/O	C _T	HS	X	X			X	X		Port A4	
-	35	40	PA5 (HS) (3)	I/O	C _T	HS	X	X			X	X		Port A5	
18	36	41	PA6 (HS)/SDA	I/O	C _T	HS	X					T		Port A6	I2C serial data
19	37	42	PA7 (HS)/SCL	I/O	C _T	HS	X					T		Port A7	I2C serial clock
20	38	43	ICCSEL (5)	I											ICC mode selection
21	39	44	\overline{RESET}	I/O	C _T										Top priority non maskable interrupt.
22	40	45	V _{SS_2} (2)	S											Digital ground voltage
23	41	46	OSC2	O											Resonator oscillator inverter output
24	42	47	OSC1	I											External clock input or resonator oscillator inverter input
25	43	48	V _{DD_2} (2)	S											Digital main supply voltage
26	44	1	PE0/TDO	I/O	C _T		X	X			X	X	Port E0	SCI transmit data out	

Table 3. Device pin description (continued)

Pin n°			Pin name	Type	Level		Port						Main function (after reset)	Alternate function
LQFP32	LQFP44	LQFP48			Input	Output	Input (1)				Output			
							float	wpu	int	ana	OD	PP		
27	1	2	PE1/RDI	I/O	C _T		X		ei0		X	X	Port E1	SCI receive data in
28	2	3	PB0	I/O	C _T		X		ei2		X	X	Port B0	
-	3	4	PB1 ⁽³⁾	I/O	C _T		X		ei2		X	X	Port B1	
-	4	5	PB2 ⁽³⁾	I/O	C _T		X		ei2		X	X	Port B2	
29	5	6	PB3	I/O	C _T		X		ei2		X	X	Port B3	
30	6	7	PB4 (HS)	I/O	C _T	HS	X		ei3		X	X	Port B4	
31	7	8	PD0/AIN0	I/O	C _T		X	X		X	X	X	Port D0	ADC analog input 0
32	8	9	PD1/AIN1	I/O	C _T		X	X		X	X	X	Port D1	ADC analog input 1
-	9	10	PD2/AIN2	I/O	C _T		X	X		X	X	X	Port D2	ADC analog input 2
-	10	11	PD3/AIN3	I/O	C _T		X	X		X	X	X	Port D3	ADC analog input 3
-	11	12	PD4/AIN4	I/O	C _T		X	X		X	X	X	Port D4	ADC analog input 4
-	12	13	PD5/AIN5	I/O	C _T		X	X		X	X	X	Port D5	ADC analog input 5

1. In the interrupt input column, "eiX" defines the associated external interrupt vector. If the weak pull-up column (wpu) is merged with the interrupt column (int), then the I/O configuration is pull-up interrupt input, else the configuration is floating interrupt input.
2. It is mandatory to connect all available V_{DD} and V_{DDA} pins to the supply voltage and all V_{SS} and V_{SSA} pins to ground.
3. Pulled-up by hardware when not present on the package.
4. In the open drain output column, "T" defines a true open drain I/O (P-Buffer and protection diode to V_{DD} are not implemented).
5. Internal weak pull-down.

3 Register and memory map

As shown in [Figure 5](#), the MCU is capable of addressing 64 Kbytes of memories and I/O registers.

The available memory locations consist of 128 bytes of register locations, up to 1 Kbyte of RAM, 256 bytes of Data EEPROM and up to 16 Kbytes of user program memory. The RAM space includes up to 256 bytes for the stack from 0100h to 01FFh.

The highest address bytes contain the user reset and interrupt vectors.

Figure 5. Memory map

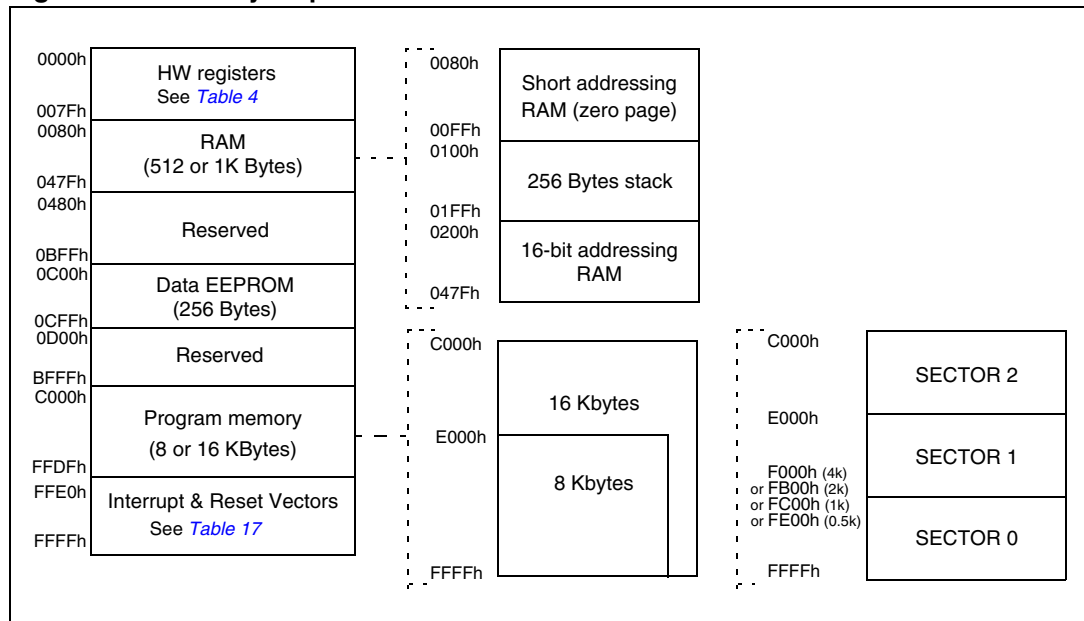

Table 4. Hardware register map

Address	Block	Register label	Register name	Reset status (1)	Remarks (2)
0000h 0001h 0002h	Port A ⁽³⁾	PADR	Port A Data Register	00h ⁽⁴⁾	R/W
		PADDR	Port A Data Direction Register	00h	R/W
		PAOR	Port A Option Register	00h	R/W
0003h 0004h 0005h	Port B ⁽³⁾	PBDR	Port B Data Register	00h ⁽⁴⁾	R/W
		PBDDR	Port B Data Direction Register	00h	R/W
		PBOR	Port B Option Register	00h	R/W
0006h 0007h 0008h	Port C ⁽³⁾	PCDR	Port C Data Register	00h ⁽⁴⁾	R/W
		PCDDR	Port C Data Direction Register	00h	R/W
		PCOR	Port C Option Register	00h	R/W
0009h 000Ah 000Bh	Port D ⁽³⁾	PDADR	Port D Data Register	00h ⁽⁴⁾	R/W
		PDDDR	Port D Data Direction Register	00h	R/W
		PDOR	Port D Option Register	00h	R/W
000Ch 000Dh 000Eh	Port E ⁽³⁾	PEDR	Port E Data Register	00h ⁽⁴⁾	R/W
		PEDDR	Port E Data Direction Register	00h	R/W
		PEOR	Port E Option Register	00h	R/W
000Fh 0010h 0011h	Port F ⁽³⁾	PFDR	Port F Data Register	00h ⁽⁴⁾	R/W
		PFDDR	Port F Data Direction Register	00h	R/W
		PFOR	Port F Option Register	00h	R/W
0012h to 0016h	Reserved area (5 bytes)				
0017h 0018h	RC	RCCRH	RC oscillator Control Register High	FFh	R/W
		RCCRL	RC oscillator Control Register Low	03h	R/W
0019h	Reserved area (1 byte)				
001Ah to 001Fh	DM ⁽⁵⁾	Reserved area (6 bytes)			
00020h	EEPROM	EECSR	Data EEPROM Control/Status Register	00h	R/W
0021h 0022h 0023h	SPI	SPIDR	SPI Data I/O Register	xxh	R/W
		SPICR	SPI Control Register	0xh	R/W
		SPICSR	SPI Control Status Register	00h	R/W
0024h 0025h 0026h 0027h	ITC	ISPR0	Interrupt Software Priority Register 0	FFh	R/W
		ISPR1	Interrupt Software Priority Register 1	FFh	R/W
		ISPR2	Interrupt Software Priority Register 2	FFh	R/W
		ISPR3	Interrupt Software Priority Register 3	FFh	R/W
0028h		EICR	External Interrupt Control Register	00h	R/W
00029h	Flash	FCSR	Flash Control/Status Register	00h	R/W
002Ah	WWDG	WDGCR	Watchdog Control Register	7Fh	R/W
002Bh	SI	SICSR	System Integrity Control/Status Register	000x 000xb	R/W
002Ch 002Dh	MCC	MCCSR	Main Clock Control/Status Register	00h	R/W
		MCCBCR	MCC Beep Control Register	00h	R/W
002Eh 002Fh	AWU	AWUCSR	AWU Control/Status Register	00h	R/W
		AWUPR	AWU Prescaler Register	FFh	R/W
0030h	WWDG	WDGWR	Window Watchdog Control Register	7Fh	R/W

Table 4. Hardware register map (continued)

Address	Block	Register label	Register name	Reset status (1)	Remarks (2)
0031h	TIMER A	TACR2	Timer A Control Register 2	00h	R/W
0032h		TACR1	Timer A Control Register 1	00h	R/W
0033h		TACSR	Timer A Control/Status Register	xxh	R/W
0034h		TAIC1HR	Timer A Input Capture 1 High Register	xxh	Read Only
0035h		TAIC1LR	Timer A Input Capture 1 Low Register	xxh	Read Only
0036h		TAOC1HR	Timer A Output Compare 1 High Register	80h	R/W
0037h		TAOC1LR	Timer A Output Compare 1 Low Register	00h	R/W
0038h		TACHR	Timer A Counter High Register	FFh	Read Only
0039h		TACL	Timer A Counter Low Register	FCh	Read Only
003Ah		TAACHR	Timer A Alternate Counter High Register	FFh	Read Only
003Bh		TAACL	Timer A Alternate Counter Low Register	FCh	Read Only
003Ch		TAIC2HR	Timer A Input Capture 2 High Register	xxh	Read Only
003Dh		TAIC2LR	Timer A Input Capture 2 Low Register	xxh	Read Only
003Eh		TAOC2HR	Timer A Output Compare 2 High Register	80h	R/W
003Fh		TAOC2LR	Timer A Output Compare 2 Low Register	00h	R/W
0040h	Reserved area (1 Byte)				
0041h	TIMER B	TBCR2	Timer B Control Register 2	00h	R/W
0042h		TBCR1	Timer B Control Register 1	00h	R/W
0043h		TBCSR	Timer B Control/Status Register	xxh	R/W
0044h		TBIC1HR	Timer B Input Capture 1 High Register	xxh	Read Only
0045h		TBIC1LR	Timer B Input Capture 1 Low Register	xxh	Read Only
0046h		TBOC1HR	Timer B Output Compare 1 High Register	80h	R/W
0047h		TBOC1LR	Timer B Output Compare 1 Low Register	00h	R/W
0048h		TBCHR	Timer B Counter High Register	FFh	Read Only
0049h		TBCLR	Timer B Counter Low Register	FCh	Read Only
004Ah		TBACHR	Timer B Alternate Counter High Register	FFh	Read Only
004Bh		TBACL	Timer B Alternate Counter Low Register	FCh	Read Only
004Ch		TBIC2HR	Timer B Input Capture 2 High Register	xxh	Read Only
004Dh		TBIC2LR	Timer B Input Capture 2 Low Register	xxh	Read Only
004Eh		TBOC2HR	Timer B Output Compare 2 High Register	80h	R/W
004Fh		TBOC2LR	Timer B Output Compare 2 Low Register	00h	R/W
0050h	SCI	SCISR	SCI Status Register	C0h	Read Only
0051h		SCIDR	SCI Data Register	xxh	R/W
0052h		SCIBRR	SCI Baud Rate Register	00h	R/W
0053h		SCICR1	SCI Control Register 1	x000 0000b	R/W
0054h		SCICR2	SCI Control Register 2	00h	R/W
0055h			Reserved area	--	
0056h		SCIERPR	SCI Extended Receive Prescaler Register	00h	R/W
0057h		SCIETPR	SCI Extended Transmit Prescaler Register	00h	R/W
0058h	I ² C	I2CCR	I ² C Control Register	00h	R/W
0059h		I2CSR1	I ² C Status Register 1	00h	Read Only
005Ah		I2CSR2	I ² C Status Register 2	00h	Read Only
005Bh		I2CCR	I ² C Clock Control Register	00h	R/W
005Ch		I2COAR1	I ² C Own Address Register 1	00h	R/W
005Dh		I2COAR2	I ² C Own Address Register2	40h	R/W
005Eh		I2CDR	I ² C Data Register	00h	R/W
005Fh	Reserved area (1 byte)				

Table 4. Hardware register map (continued)

Address	Block	Register label	Register name	Reset status (1)	Remarks (2)
0060h	I ² C3SNS	I2C3SCR1	I ² C3SNS Control Register 1	00h	R/W
0061h		I2C3SCR2	I ² C3SNS Control Register 2	00h	R/W
0062h		I2C3SSR	I ² C3SNS Status Register	00h	Read Only
0063h		I2C3SBCR	I ² C3SNS Byte Count Register	00h	Read Only
0064h		I2C3SSAR1	I ² C3SNS Slave Address 1 Register	00h	R/W
0065h		I2C3SCAR1	I ² C3SNS Current Address 1 Register	00h	R/W
0066h		I2C3SSAR2	I ² C3SNS Slave Address 2 Register	00h	R/W
0067h		I2C3SCAR2	I ² C3SNS Current Address 2 Register	00h	R/W
0068h		I2C3SSAR3	I ² C3SNS Slave Address 3 Register	00h	R/W
0069h		I2C3SCAR3	I ² C3SNS Current Address 3 Register	00h	R/W
0070h	ADC	ADCCSR	A/D Control Status Register	00h	R/W
0071h		ADCDRH	A/D Data Register High	xxh	Read Only
0072h		ADCRL	A/D Data Low Register	0000 00xxb	Read Only
0073h to 007Fh	Reserved area (13 bytes)				

1. x = undefined.
2. R/W = read/write.
3. The bits associated with unavailable pins must always keep their reset value.
4. The contents of the I/O port DR registers are readable only in output configuration. In input configuration, the values of the I/O pins are returned instead of the DR register contents.
5. For a description of the Debug Module registers, see ST7 ICC protocol reference manual.

4 Flash program memory

4.1 Introduction

The ST7 single voltage extended Flash (XFlash) is a non-volatile memory that can be electrically erased and programmed either on a byte-by-byte basis or up to 32 bytes in parallel.

The XFlash devices can be programmed off-board (plugged in a programming tool) or on-board using In-Circuit Programming or In-Application Programming.

The array matrix organization allows each sector to be erased and reprogrammed without affecting other sectors.

4.2 Main features

- ICP (in-circuit programming)
- IAP (in-application programming)
- ICT (in-circuit testing) for downloading and executing user application test patterns in RAM
- Sector 0 size configurable by option byte
- Read-out and write protection

4.3 Programming modes

The ST7 can be programmed in three different ways:

- Insertion in a programming tool
In this mode, Flash sectors 0 and 1, option byte row and data EEPROM (if present) can be programmed or erased.
- In-circuit programming
In this mode, Flash sectors 0 and 1, option byte row and data EEPROM (if present) can be programmed or erased without removing the device from the application board.
- In-application programming
In this mode, sector 1 and data EEPROM (if present) can be programmed or erased without removing the device from the application board and while the application is running.

4.3.1 In-circuit programming (ICP)

ICP uses a protocol called ICC (in-circuit communication) which allows an ST7 plugged on a printed circuit board (PCB) to communicate with an external programming device connected via cable. ICP is performed in three steps:

Switch the ST7 to ICC mode (in-circuit communications). This is done by driving a specific signal sequence on the ICCCLK/DATA pins while the $\overline{\text{RESET}}$ pin is pulled low. When the ST7 enters ICC mode, it fetches a specific reset vector which points to the ST7 System Memory containing the ICC protocol routine. This routine enables the ST7 to receive bytes from the ICC interface.

- Download ICP Driver code in RAM from the ICCDATA pin
- Execute ICP Driver code in RAM to program the Flash memory

Depending on the ICP Driver code downloaded in RAM, Flash memory programming can be fully customized (number of bytes to program, program locations, or selection of the serial communication interface for downloading).

4.3.2 In-application programming (IAP)

This mode uses an IAP Driver program previously programmed in Sector 0 by the user (in ICP mode).

This mode is fully controlled by user software. This allows it to be adapted to the user application (user-defined strategy for entering programming mode, choice of communications protocol used to fetch the data to be stored etc.)

IAP mode can be used to program any memory areas except Sector 0, which is write/erase protected to allow recovery in case errors occur during the programming operation.

4.4 ICC interface

ICP needs a minimum of 4 and up to 7 pins to be connected to the programming tool. These pins are:

- $\overline{\text{RESET}}$: device reset
- V_{SS} : device power supply ground
- ICCCLK: ICC output serial clock pin
- ICCDATA: ICC input serial data pin
- ICCSEL: ICC selection
- OSC1: main clock input for external source (not required on devices without OSC1/OSC2 pins)
- V_{DD} : application board power supply (optional, see Note 3)

- Note:*
- 1 *If the ICCCLK or ICCDATA pins are only used as outputs in the application, no signal isolation is necessary. As soon as the Programming Tool is plugged to the board, even if an ICC session is not in progress, the ICCCLK and ICCDATA pins are not available for the application. If they are used as inputs by the application, isolation such as a serial resistor has to be implemented in case another device forces the signal. Refer to the Programming Tool documentation for recommended resistor values.*
 - 2 *During the ICP session, the programming tool must control the $\overline{\text{RESET}}$ pin. This can lead to conflicts between the programming tool and the application reset circuit if it drives more than 5 mA at high level (push pull output or pull-up resistor < 1,000). A schottky diode can be used*

to isolate the application reset circuit in this case. When using a classical RC network with $R > 1,000$ or a reset management IC with open drain output and pull-up resistor $> 1,000$, no additional components are needed. In all cases the user must ensure that no external reset is generated by the application during the ICC session.

- 3 The use of Pin 7 of the ICC connector depends on the Programming Tool architecture. This pin must be connected when using most ST Programming Tools (it is used to monitor the application power supply). Please refer to the Programming Tool manual.
- 4 Pin 9 has to be connected to the OSC1 pin of the ST7 when the clock is not available in the application or if the selected clock option is not programmed in the option byte. ST7 devices with multi-oscillator capability need to have OSC2 grounded in this case.
- 5 In "enabled option byte" mode (38-pulse ICC mode), the internal RC oscillator is forced as a clock source, regardless of the selection in the option byte.

Caution: During normal operation, the ICCCLK pin must be internally or externally pulled-up (external pull-up of 10 kΩ mandatory in noisy environment) to avoid entering ICC mode unexpectedly during a reset. In the application, even if the pin is configured as an output, any reset will put it back in input pull-up.

Figure 6. Typical ICC interface

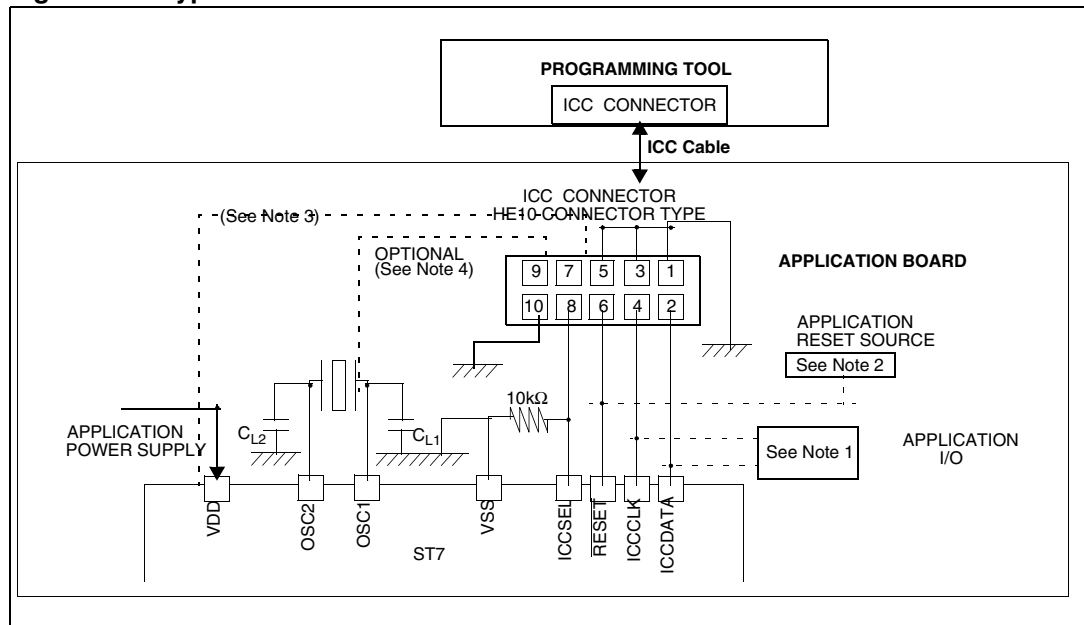

4.5 Memory protection

There are two different types of memory protection: Read Out Protection and Write/Erase Protection which can be applied individually.

4.5.1 Readout protection

Readout protection, when selected, provides a protection against program memory content extraction and against write access to Flash memory. Even if no protection can be considered as totally unbreakable, the feature provides a very high level of protection for a general purpose microcontroller. Both program and data E² memory are protected.

In Flash devices, this protection is removed by reprogramming the option. In this case, both program and data E² memory are automatically erased, and the device can be reprogrammed.

Read-out protection selection depends on the device type:

- In Flash devices, it is enabled and removed through the FMP_R bit in the option byte.
- In ROM devices, it is enabled by mask option specified in the Option List.

4.5.2 Flash write/erase protection

Write/erase protection, when set, makes it impossible to both overwrite and erase program memory. It does not apply to E² data. Its purpose is to provide advanced security to applications and prevent any change being made to the memory content.

Warning: Once set, Write/erase protection can never be removed. A write-protected Flash device is no longer reprogrammable.

Write/erase protection is enabled through the FMP_W bit in the option byte.

4.6 Register description

4.6.1 Flash control/status register (FCSR)

Reset value: 0000 0000 (00h)
 1st RASS Key: 0101 0110 (56h)
 2nd RASS Key: 1010 1110 (AEh)

7							0
0	0	0	0	0	OPT	LAT	PGM
Read/Write							

Note: This register is reserved for programming using ICP, IAP or other programming methods. It controls the XFlash programming and erasing operations. For details on XFlash programming, refer to the ST7 Flash Programming Reference Manual.

When an EPB or another programming tool is used (in socket or ICP mode), the RASS keys are sent automatically.

5 Data EEPROM

5.1 Introduction

The electrically erasable programmable read only memory can be used as a non-volatile backup for storing data. Using the EEPROM requires a basic access protocol described in this chapter.

5.2 Main features

- Up to 32 bytes programmed in the same cycle
- EEPROM mono-voltage (charge pump)
- Chained erase and programming cycles
- Internal control of the global programming cycle duration
- Wait mode management
- Readout protection

Figure 7. EEPROM block diagram

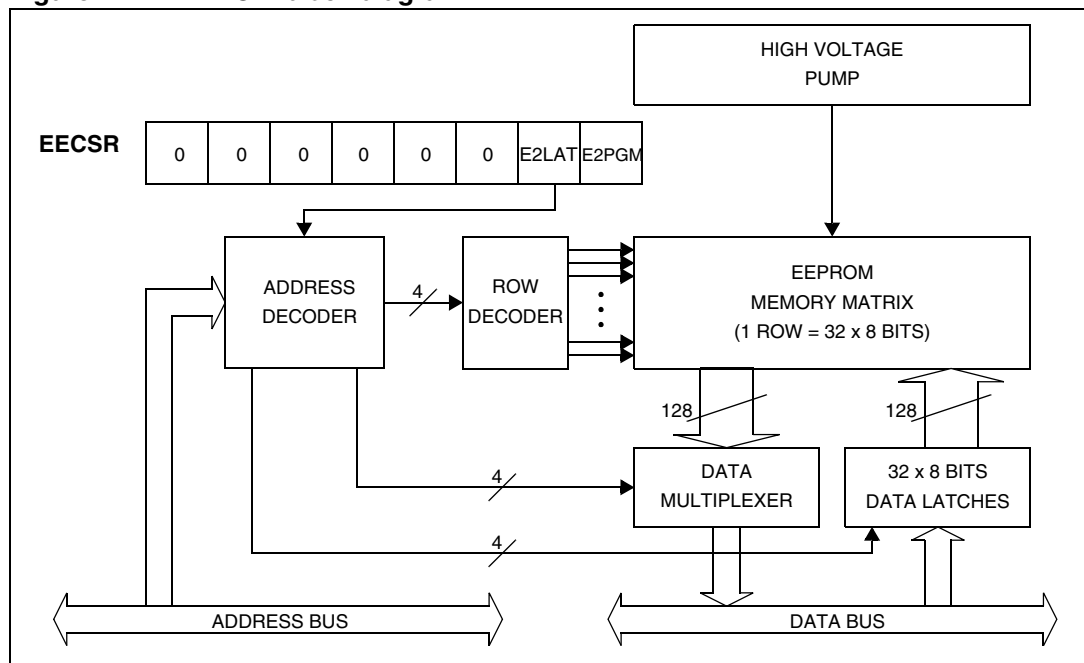

5.3 Memory access

The Data EEPROM memory read/write access modes are controlled by the E2LAT bit of the EEPROM Control/Status register (EECSR). The flowchart in [Figure 8](#) describes these different memory access modes.

Read operation (E2LAT = 0)

The EEPROM can be read as a normal ROM location when the E2LAT bit of the EECSR register is cleared.

On this device, Data EEPROM can also be used to execute machine code. Take care not to write to the Data EEPROM while executing from it. This would result in an unexpected code being executed.

Write operation (E2LAT = 1)

To access the write mode, the E2LAT bit has to be set by software (the E2PGM bit remains cleared). When a write access to the EEPROM area occurs, the value is latched inside the 32 data latches according to its address.

When E2PGM bit is set by the software, all the previous bytes written in the data latches (up to 32) are programmed in the EEPROM cells. The effective high address (row) is determined by the last EEPROM write sequence. To avoid wrong programming, the user must take care that all the bytes written between two programming sequences have the same high address: only the five Least Significant Bits of the address can change.

The programming cycle is fully completed when the E2PGM bit is cleared.

Note: Care should be taken during the programming cycle. Writing to the same memory location will over-program the memory (logical AND between the two write access data results) because the data latches are only cleared at the end of the programming cycle and by the falling edge of the E2LAT bit. It is not possible to read the latched data. This note is illustrated by the [Figure 10](#).

Figure 8. Data EEPROM programming flowchart

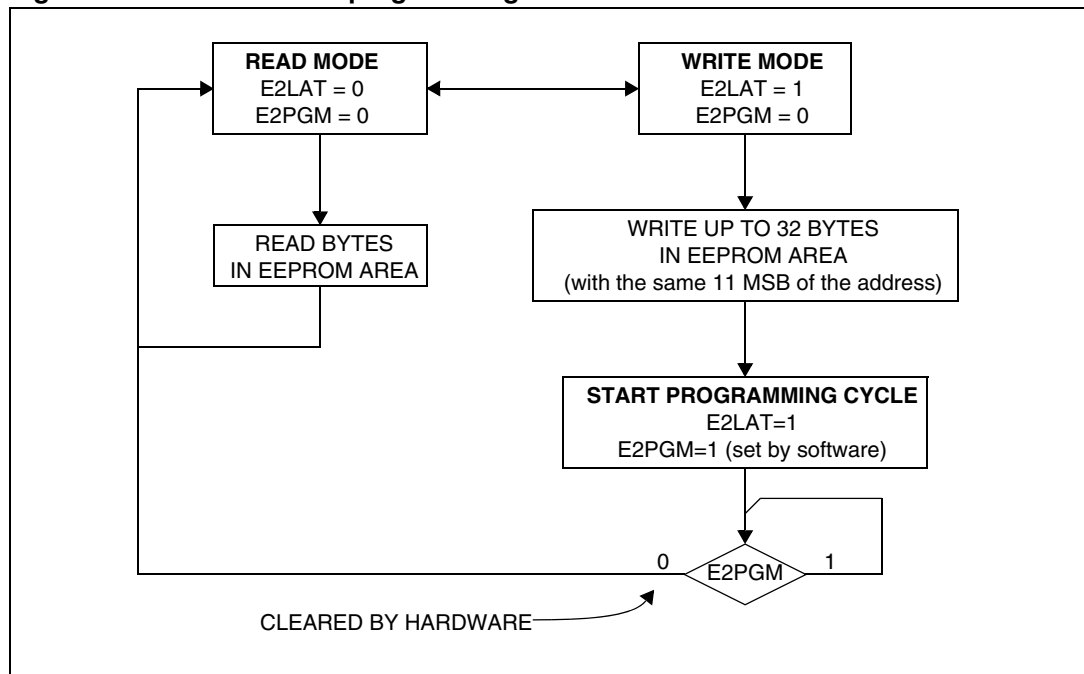
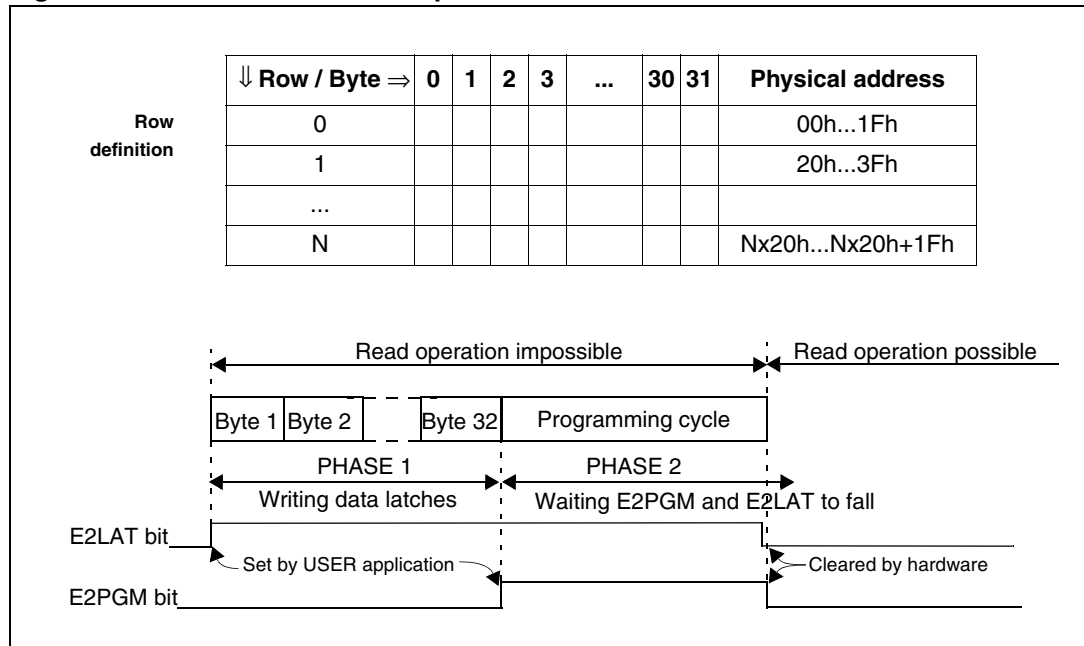

Figure 9. Data EEPROM write operation



Note: If a programming cycle is interrupted (by reset action), the integrity of the data in memory will not be guaranteed.

5.4 Power saving modes

5.4.1 Wait mode

The data EEPROM can enter Wait mode on execution of the WFI instruction of the microcontroller or when the microcontroller enters Active Halt mode. The data EEPROM will immediately enter this mode if there is no programming in progress, otherwise the data EEPROM will finish the cycle and then enter Wait mode.

5.4.2 Active-halt mode

Refer to [Wait mode](#).

5.4.3 Halt mode

The data EEPROM immediately enters Halt mode if the microcontroller executes the Halt instruction. Therefore the EEPROM will stop the function in progress, and data may be corrupted.

5.5 Access error handling

If a read access occurs while E2LAT = 1, then the data bus will not be driven.

If a write access occurs while E2LAT = 0, then the data on the bus will not be latched.

If a programming cycle is interrupted (by reset action), the integrity of the data in memory will not be guaranteed.

5.6 Data EEPROM readout protection

The readout protection is enabled through an option bit (see [Section 15.1: Option bytes](#)).

When this option is selected, the programs and data stored in the EEPROM memory are protected against read-out (including a rewrite protection). In Flash devices, when this protection is removed by reprogramming the option byte, the entire Program memory and EEPROM is first automatically erased.

Note: Both program memory and data EEPROM are protected using the same option bit.

Figure 10. Data EEPROM programming cycle

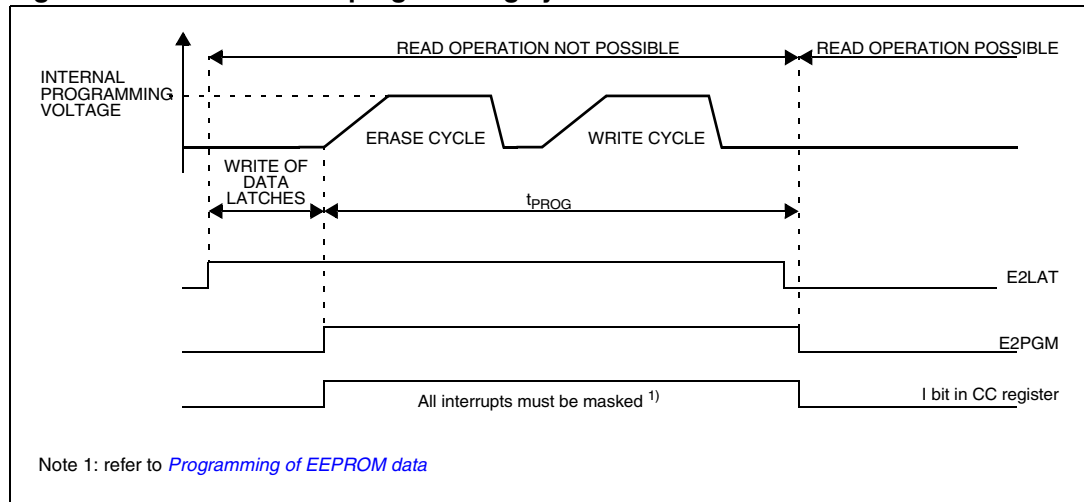

5.7 Register description

5.7.1 EEPROM control/status register (EECSR)

Reset value: 0000 0000 (00h)

7							0
0	0	0	0	0	0	E2LAT	E2PGM
Read/Write							

Bits 7:2 = Reserved, forced by hardware to 0.

Bit 1 = **E2LAT** *Latch Access Transfer*

This bit is set by software. It is cleared by hardware at the end of the programming cycle. It can only be cleared by software if the E2PGM bit is cleared.

- 0: Read mode
- 1: Write mode

Bit 0 = **E2PGM** *Programming control and status*

This bit is set by software to begin the programming cycle. At the end of the programming cycle, this bit is cleared by hardware.

- 0: Programming finished or not yet started
- 1: Programming cycle is in progress

Note: If the E2PGM bit is cleared during the programming cycle, the memory data is not guaranteed.

Table 5. Data EEPROM register map and reset values

Address (Hex.)	Register label	7	6	5	4	3	2	1	0
0020h	EECSR Reset value	0	0	0	0	0	0	E2LAT 0	E2PGM 0

6 Central processing unit

6.1 Introduction

This CPU has a full 8-bit architecture and contains six internal registers allowing efficient 8-bit data manipulation.

6.2 Main features

- Enable executing 63 basic instructions
- Fast 8-bit by 8-bit multiply
- 17 main addressing modes (with indirect addressing mode)
- Two 8-bit index registers
- 16-bit stack pointer
- Low power Halt and Wait modes
- Priority maskable hardware interrupts
- Non-maskable software/hardware interrupts

6.3 CPU registers

The six CPU registers shown in [Figure 11](#) are not present in the memory mapping and are accessed by specific instructions.

Accumulator (A)

The Accumulator is an 8-bit general purpose register used to hold operands and the results of the arithmetic and logic calculations and to manipulate data.

Index Registers (X and Y)

These 8-bit registers are used to create effective addresses or as temporary storage areas for data manipulation. (The Cross-Assembler generates a precede instruction (PRE) to indicate that the following instruction refers to the Y register.)

The Y register is not affected by the interrupt automatic procedures.

Program Counter (PC)

The program counter is a 16-bit register containing the address of the next instruction to be executed by the CPU. It is made of two 8-bit registers PCL (Program Counter Low which is the LSB) and PCH (Program Counter High which is the MSB).

Figure 11. CPU registers

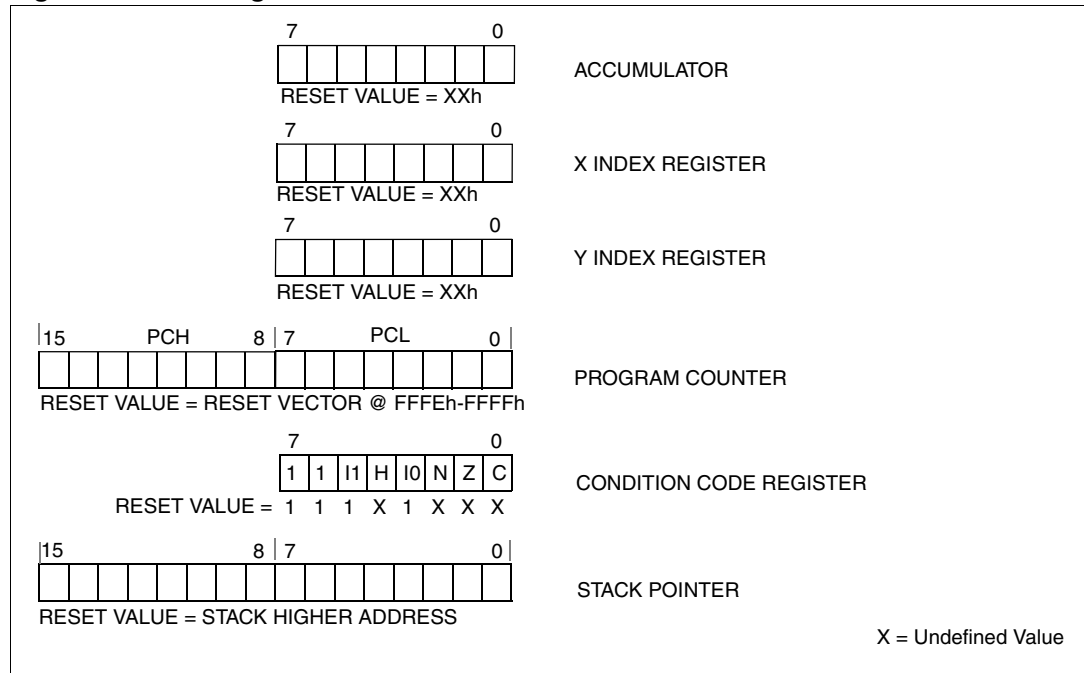

6.3.1 Condition code register (CC)

Reset value: 111x1xxx

7							0
1	1	I1	H	I0	N	Z	C
Read/Write							

The 8-bit Condition Code register contains the interrupt masks and four flags representative of the result of the instruction just executed. This register can also be handled by the PUSH and POP instructions.

These bits can be individually tested and/or controlled by specific instructions.

Arithmetic management bits

Bit 4 = **H** *Half carry*.

This bit is set by hardware when a carry occurs between bits 3 and 4 of the ALU during an ADD or ADC instructions. It is reset by hardware during the same instructions.

0: No half carry has occurred.

1: A half carry has occurred.

This bit is tested using the JRH or JRNH instruction. The H bit is useful in BCD arithmetic subroutines.

Bit 2 = **N Negative**.

This bit is set and cleared by hardware. It is representative of the result sign of the last arithmetic, logical or data manipulation. It's a copy of the result 7th bit.

0: The result of the last operation is positive or null.

1: The result of the last operation is negative (that is, the most significant bit is a logic 1).

This bit is accessed by the JRMI and JRPL instructions.

Bit 1 = **Z Zero**.

This bit is set and cleared by hardware. This bit indicates that the result of the last arithmetic, logical or data manipulation is zero.

0: The result of the last operation is different from zero.

1: The result of the last operation is zero.

This bit is accessed by the JREQ and JRNE test instructions.

Bit 0 = **C Carry/borrow**.

This bit is set and cleared by hardware and software. It indicates an overflow or an underflow has occurred during the last arithmetic operation.

0: No overflow or underflow has occurred.

1: An overflow or underflow has occurred.

This bit is driven by the SCF and RCF instructions and tested by the JRC and JRNC instructions. It is also affected by the "bit test and branch", shift and rotate instructions.

Interrupt management bits

Bits 5,3 = **I1, I0 Interrupt**

The combination of the I1 and I0 bits gives the current interrupt software priority.

Table 6. Interrupt software priority

Priority	I1	I0
Level 0 (main)	1	0
Level 1	0	1
Level 2	0	0
Level 3 (= interrupt disable)	1	1

These two bits are set/cleared by hardware when entering in interrupt. The loaded value is given by the corresponding bits in the interrupt software priority registers (IxSPR). They can be also set/cleared by software with the RIM, SIM, IRET, HALT, WFI and PUSH/POP instructions.

See the interrupt management chapter for more details.

6.3.2 Stack pointer (SP)

Reset value: 01 FFh

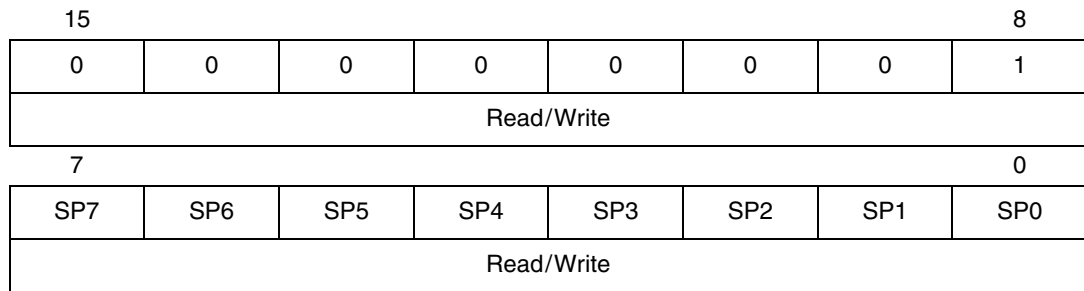

The Stack pointer is a 16-bit register which is always pointing to the next free location in the stack. It is then decremented after data has been pushed onto the stack and incremented before data is popped from the stack (see [Figure 12](#)).

Since the stack is 256 bytes deep, the 8 most significant bits are forced by hardware. Following an MCU Reset, or after a Reset Stack Pointer instruction (RSP), the Stack pointer contains its reset value (the SP7 to SP0 bits are set) which is the stack higher address.

The least significant byte of the Stack pointer (called S) can be directly accessed by an LD instruction.

Note: When the lower limit is exceeded, the Stack pointer wraps around to the stack upper limit, without indicating the stack overflow. The previously stored information is then overwritten and therefore lost. The stack also wraps in case of an underflow.

The stack is used to save the return address during a subroutine call and the CPU context during an interrupt. The user may also directly manipulate the stack by means of the PUSH and POP instructions. In the case of an interrupt, the PCL is stored at the first location pointed to by the SP. Then the other registers are stored in the next locations as shown in [Figure 12](#).

- When an interrupt is received, the SP is decremented and the context is pushed on the stack.
- On return from interrupt, the SP is incremented and the context is popped from the stack.

A subroutine call occupies two locations and an interrupt five locations in the stack area.

Figure 12. Stack manipulation example

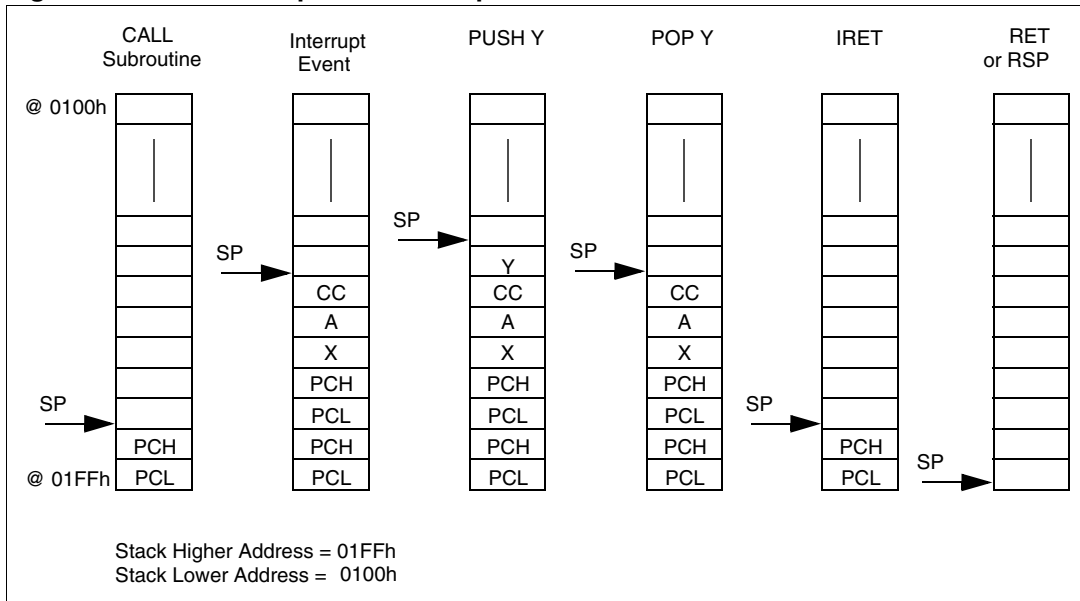

7 Supply, reset and clock management

The device includes a range of utility features for securing the application in critical situations (for example in case of a power brown-out), and reducing the number of external components.

7.1 Main features

- Clock management
 - 1 MHz high-accuracy internal RC oscillator (enabled by option byte)
 - 1 to 16 MHz External crystal/ceramic resonator (enabled by option byte)
 - External Clock Input (enabled by option byte)
 - PLL for multiplying the frequency by 8 or 4 (enabled by option byte)
- Reset sequence manager (RSM)
- System integrity management (SI)
 - Main supply low voltage detection (LVD) with reset generation (enabled by option byte)
 - Auxiliary voltage detector (AVD) with interrupt capability for monitoring the main supply (enabled by option byte)

Figure 13. Clock, reset and supply block diagram

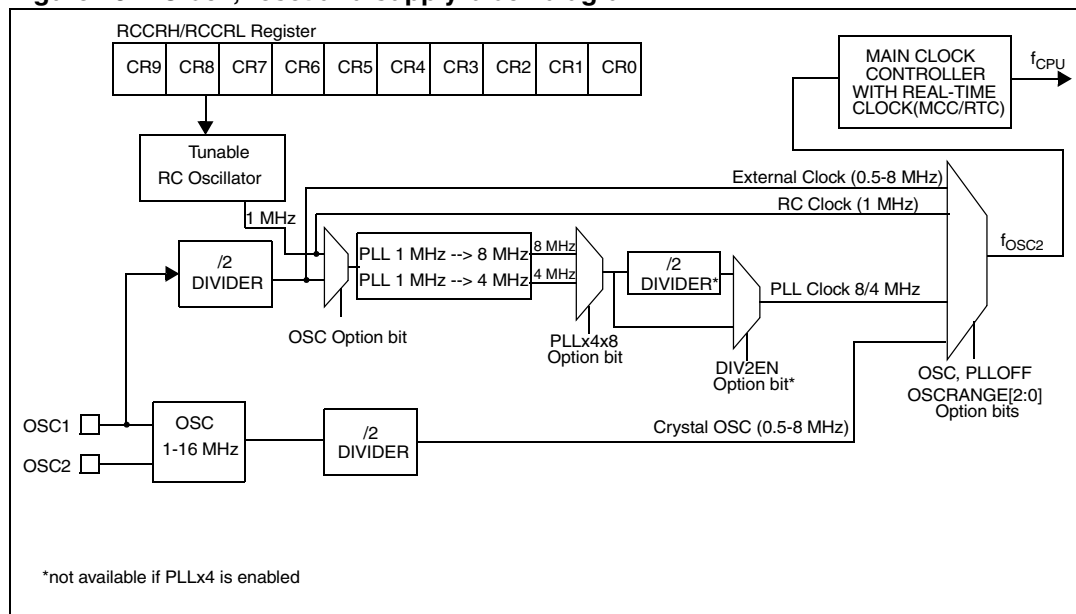

7.2 Phase locked loop

The PLL can be used to multiply a 1 MHz frequency from the RC oscillator or the external clock by 4 or 8 to obtain f_{OSC} of 4 or 8 MHz. The PLL is enabled and the multiplication factor of 4 or 8 is selected by 3 option bits. Refer to [Table 7](#) for the PLL configuration depending on the required frequency and the application voltage. Refer to [Section 15.1](#) for the option byte description.

Table 7. PLL configurations

Target ratio	V _{DD}	PLL ratio	DIV2
x4 ⁽¹⁾	2.7 V - 3.65 V	x4	OFF
x4	3.3 V - 5.5 V	x8	ON
x8		x8	OFF

1. For a target ratio of x4 between 3.3 V - 3.65 V, this is the recommended configuration.

Figure 14. PLL output frequency timing diagram

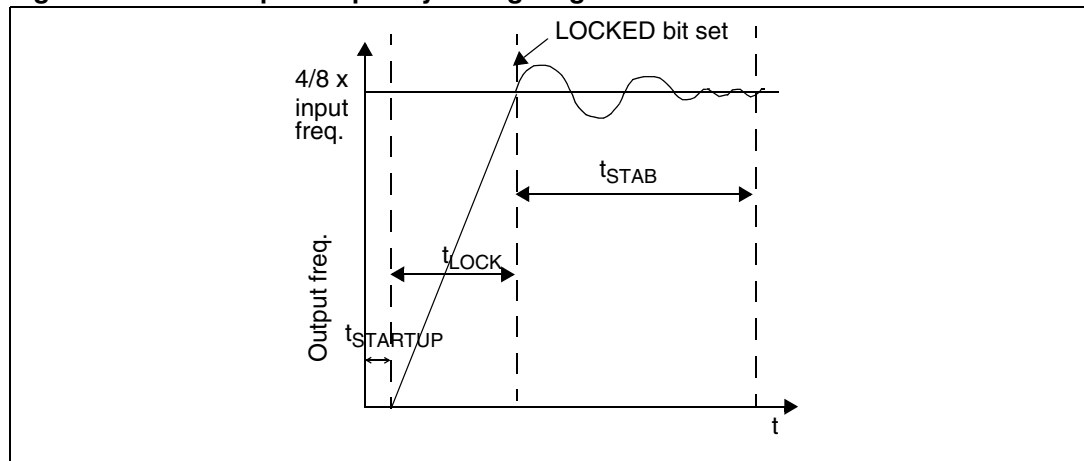

When the PLL is started, after reset or wakeup from Halt mode or AWUFH mode, it outputs the clock after a delay of $t_{STARTUP}$

When the PLL output signal reaches the operating frequency, the LOCKED bit in the SICSCR register is set. Full PLL accuracy (ACC_{PLL}) is reached after a stabilization time of t_{STAB} (see [Figure 14](#)).

Refer to [Section 7.6.5: Register description](#) for a description of the LOCKED bit in the SICSCR register.

Caution: The PLL is not recommended for applications where timing accuracy is required.

Caution: When the RC oscillator and the PLL are enabled, it is recommended to calibrate this clock through the RCCRH and RCCRL registers.

7.3 Multioscillator (MO)

The main clock of the ST7 can be generated by three different source types coming from the multioscillator block:

- an external source
- 4 crystal or ceramic resonator oscillators
- an internal high-accuracy RC oscillator

Each oscillator is optimized for a given frequency range in terms of consumption and is selectable through the option byte. The associated hardware configurations are shown in [Table 8](#). Refer to [Section 13: Electrical characteristics](#) for more details.

Caution: The OSC1 and/or OSC2 pins must not be left unconnected. For the purposes of Failure Mode and Effect Analysis, it should be noted that if the OSC1 and/or OSC2 pins are left unconnected, the ST7 main oscillator may start and, in this configuration, could generate an f_{OSC} clock frequency in excess of the allowed maximum (>16 MHz), putting the ST7 in an unsafe/undefined state. The product behavior must therefore be considered undefined when the OSC pins are left unconnected.

7.3.1 External clock source

In this external clock mode, a clock signal (square, sinus or triangle) with ~50% duty cycle has to drive the OSC1 pin while the OSC2 pin is tied to ground.

7.3.2 Crystal/ceramic oscillators

This family of oscillators has the advantage of producing a very accurate rate on the main clock of the ST7. The selection within a list of 4 oscillators with different frequency ranges has to be done by option byte in order to reduce consumption (refer to [Section 15.1: Option bytes](#) for more details on the frequency ranges). In this mode of the multi-oscillator, the resonator and the load capacitors have to be placed as close as possible to the oscillator pins in order to minimize output distortion and startup stabilization time. The loading capacitance values must be adjusted according to the selected oscillator.

These oscillators are not stopped during the reset phase to avoid losing time in the oscillator startup phase.

Table 8. ST7 clock sources

Hardware configuration	
External clock	
Crystal/ceramic resonators	
Internal RC oscillator	

7.3.3 Internal RC oscillator

The device contains a high-precision internal RC oscillator. It must be calibrated to obtain the frequency required in the application. This is done by software writing a calibration value in the RCCRH and RCCRL Registers.

Whenever the microcontroller is reset, the RCCR returns to its default value (FF 03h), i.e. each time the device is reset, the calibration value must be loaded in the RCCRH and RCCRL registers. Predefined calibration values are stored in XFlash for 3 and 5V V_{DD} supply voltages at 25 °C, as shown in the following table:

Table 9. Calibration values

RCCR	Conditions	Address
RCCR0	$V_{DD} = 5\text{ V}$ $T_A = 25\text{ °C}$ $f_{RC} = 1\text{ MHz}$	BEE0, BEE1
RCCR1	$V_{DD} = 3\text{ V}$ $T_A = 25\text{ °C}$ $f_{RC} = 1\text{ MHz}$	BEE4, BEE5

Note: To improve clock stability, it is recommended to place a decoupling capacitor between the V_{DD} and V_{SS} pins.

These two 10-bit values are systematically programmed by ST.

RCCR0 and RCCR1 calibration values will be erased if the read-out protection bit is reset after it has been set. See [Section 4.5: Memory protection](#).

Caution: If the voltage or temperature conditions change in the application, the frequency may need to be recalibrated.

Refer to application note AN1324 for information on how to calibrate the RC frequency using an external reference signal.

7.4 Register description

7.4.1 RC control register (RCCRH)

Reset value: 1111 1111 (FFh)

7							0
CR9	CR8	CR7	CR6	CR5	CR4	CR3	CR2
Read/Write							

Bits 7:0 = **CR[9:2]** RC oscillator frequency adjustment bits

7.4.2 RC control register (RCCRL)

Reset value: 0000 0011 (03h)

7							0
0	0	0	0	0	0	CR1	CR0
Read/Write							

Bits 7:2 = Reserved, must be kept cleared.

Bits 1:0 = **CR[1:0]** RC Oscillator Frequency Adjustment Bits

This 10-bit value must be written immediately after reset to adjust the RC oscillator frequency in order to obtain the specified accuracy. The application can store the correct value for each voltage range in EEPROM and write it to this register at startup.
 0000h = maximum available frequency
 03FFh = lowest available frequency

Note: To tune the oscillator, write a series of different values in the register until the correct frequency is reached. The fastest method is to use a dichotomy starting with 200h.

7.5 Reset sequence manager (RSM)

7.5.1 Introduction

The reset sequence manager includes three reset sources as shown in [Figure 16](#):

- External $\overline{\text{RESET}}$ source pulse
- Internal LVD reset (low voltage detection)
- Internal watchdog reset

Note: A reset can also be triggered following the detection of an illegal opcode or prebyte code. Refer to [Section 12.2.1: Illegal opcode reset on page 196](#) for further details.

These sources act on the $\overline{\text{RESET}}$ pin and it is always kept low during the delay phase.

The reset service routine vector is fixed at addresses FFFEh-FFFFh in the ST7 memory map.

The basic reset sequence consists of 3 phases as shown in [Figure 15](#):

- Active phase depending on the reset source
- 256 or 4096 CPU clock cycle delay (selected by option byte)
- reset vector fetch

Caution: When the ST7 is unprogrammed or fully erased, the Flash is blank and the reset vector is not programmed. For this reason, it is recommended to keep the $\overline{\text{RESET}}$ pin in low state until programming mode is entered, in order to avoid unwanted behavior.

The 256 or 4096 CPU clock cycle delay allows the oscillator to stabilize and ensures that recovery has taken place from the Reset state. The shorter or longer clock cycle delay should be selected by option byte to correspond to the stabilization time of the external oscillator used in the application (see [Section 15.1: Option bytes](#)).

The reset vector fetch phase duration is 2 clock cycles.

Figure 15. reset sequence phases

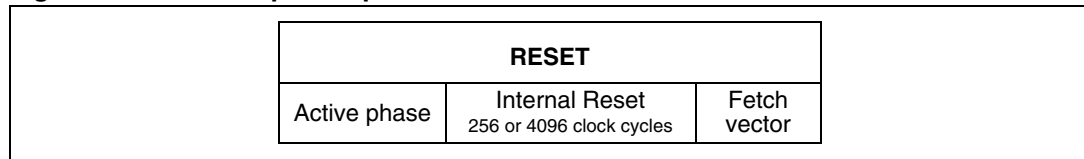

7.5.2 Asynchronous external $\overline{\text{RESET}}$ pin

The $\overline{\text{RESET}}$ pin is both an input and an open-drain output with integrated R_{ON} weak pull-up resistor. This pull-up has no fixed value but varies in accordance with the input voltage. It can be pulled low by external circuitry to reset the device. See [Section 13: Electrical characteristics](#) for more details.

A reset signal originating from an external source must have a duration of at least $t_{\text{h(RSTL)in}}$ in order to be recognized (see [Figure 17](#)). This detection is asynchronous and therefore the MCU can enter reset state even in Halt mode.

Figure 16. Reset block diagram

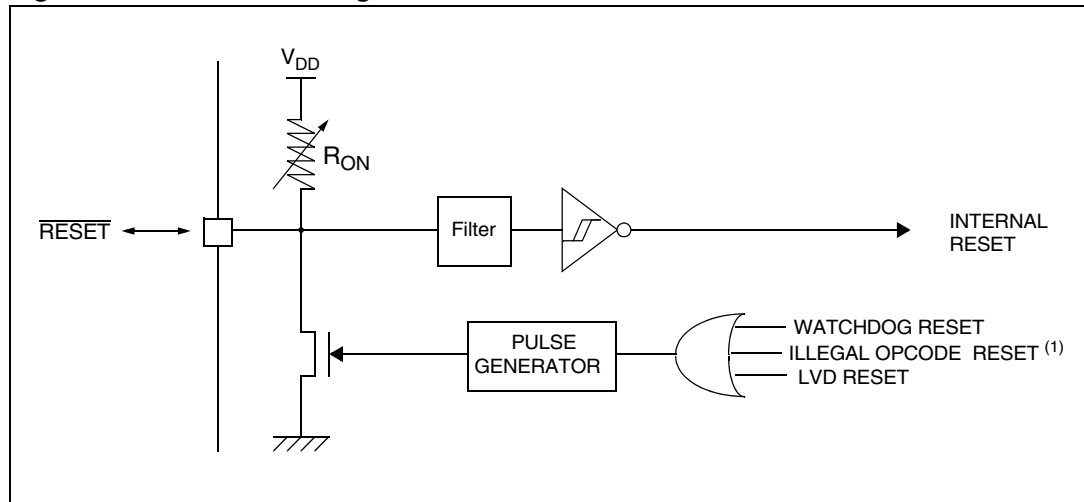

1. See [Section 12.2.1: Illegal opcode reset](#) for more details on illegal opcode reset conditions.

The $\overline{\text{RESET}}$ pin is an asynchronous signal which plays a major role in EMS performance. In a noisy environment, it is recommended to follow the guidelines mentioned in [Section 13: Electrical characteristics](#).

If the external $\overline{\text{RESET}}$ pulse is shorter than $t_{\text{w(RSTL)out}}$ (see short ext. Reset in [Figure 17](#)), the signal on the $\overline{\text{RESET}}$ pin may be stretched. Otherwise the delay will not be applied (see long ext. Reset in [Figure 17](#)). Starting from the external $\overline{\text{RESET}}$ pulse recognition, the device $\overline{\text{RESET}}$ pin acts as an output that is pulled low during at least $t_{\text{w(RSTL)out}}$.

7.5.3 External power-on reset

If the LVD is disabled by option byte, to start up the microcontroller correctly, the user must ensure by means of an external reset circuit that the reset signal is held low until V_{DD} is over the minimum level specified for the selected f_{OSC} frequency (see [Section 13.3: Operating conditions](#)).

A proper reset signal for a slow rising V_{DD} supply can generally be provided by an external RC network connected to the $\overline{\text{RESET}}$ pin.

7.5.4 Internal low-voltage detector (LVD) reset

Two different reset sequences caused by the internal LVD circuitry can be distinguished:

- Power-on reset
- Voltage-drop reset

The device $\overline{\text{RESET}}$ pin acts as an output that is pulled low when $V_{DD} < V_{IT+}$ (rising edge) or $V_{DD} < V_{IT-}$ (falling edge) as shown in [Figure 17](#).

The LVD filters spikes on V_{DD} larger than $t_{g(VDD)}$ to avoid parasitic resets.

Note: It is recommended to make sure that the V_{DD} supply voltage rises monotonously when the device is exiting from Reset, to ensure the application functions properly.

7.5.5 Internal watchdog reset

The reset sequence generated by a internal Watchdog counter overflow is shown in [Figure 17](#).

Starting from the Watchdog counter underflow, the device $\overline{\text{RESET}}$ pin acts as an output that is pulled low during at least $t_{w(RSTL)out}$.

Figure 17. Reset sequences

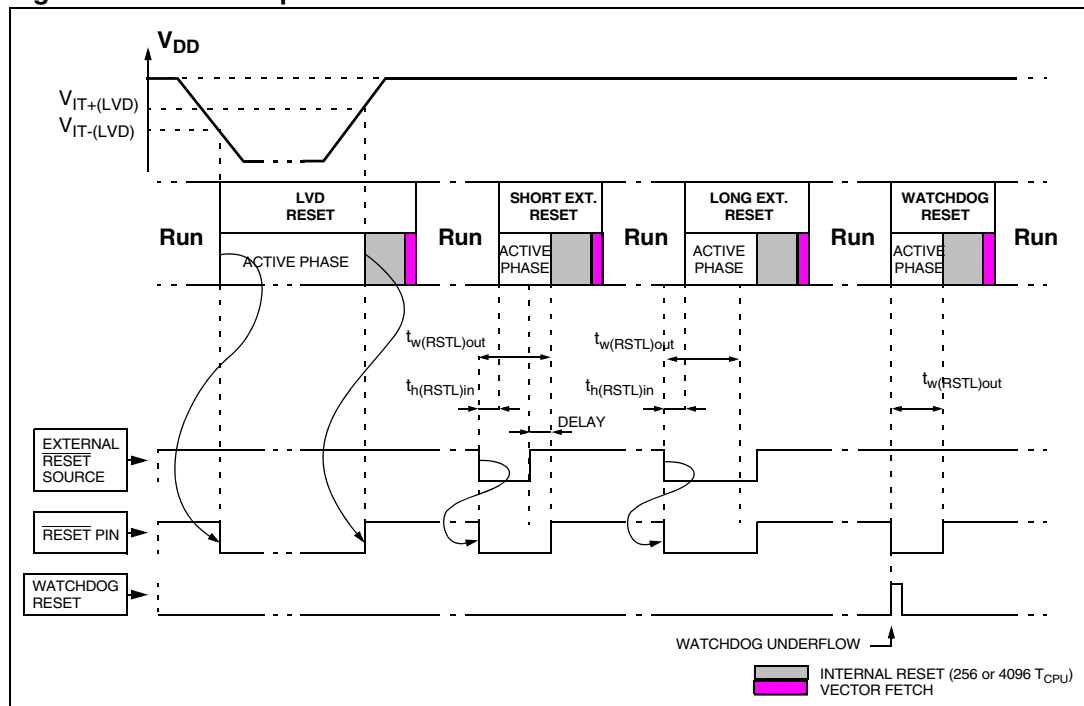

7.6 System integrity management (SI)

The system integrity management block contains the low-voltage detector (LVD) and auxiliary-voltage detector (AVD) functions. It is managed by the SICSR register.

Note: A reset can also be triggered following the detection of an illegal opcode or prebyte code. Refer to [Section 12.2.1: Illegal opcode reset](#) for further details.

7.6.1 Low-voltage detector (LVD)

The low-voltage detector function (LVD) generates a static reset when the V_{DD} supply voltage is below a V_{IT-} reference value. This means that it secures the power-up as well as the power-down keeping the ST7 in reset.

The V_{IT-} reference value for a voltage drop is lower than the V_{IT+} reference value for power-on, in order to avoid a parasitic reset when the MCU starts running and sinks current on the supply (hysteresis).

The LVD Reset circuitry generates a reset when V_{DD} is below:

- V_{IT+} when V_{DD} is rising
- V_{IT-} when V_{DD} is falling

The LVD function is illustrated in [Figure 18](#).

The LVD is an optional function which can be selected by option byte.

Note: **LVD threshold configuration:** the voltage threshold can be configured by option byte to be low, medium or high. The configuration should be chosen depending on the f_{OSC} and V_{DD} parameters in the application. When correctly configured, the LVD ensures safe power-on and power-off conditions for the microcontroller without using any external components. To determine which LVD thresholds to use:

- Define the minimum operating voltage for the application $V_{APP(min)}$.
- Refer to [Section 13: Electrical characteristics](#) to get the minimum operating voltage for the MCU at the application frequency $V_{DD(min)}$.
- Select the LVD threshold that ensures that the internal reset is released at $V_{APP(min)}$ and activated at $V_{DD(MCUmin)}$.

During a low-voltage detector reset, the \overline{RESET} pin is held low, thus permitting the MCU to reset other devices.

Figure 18. Low voltage detector vs. reset

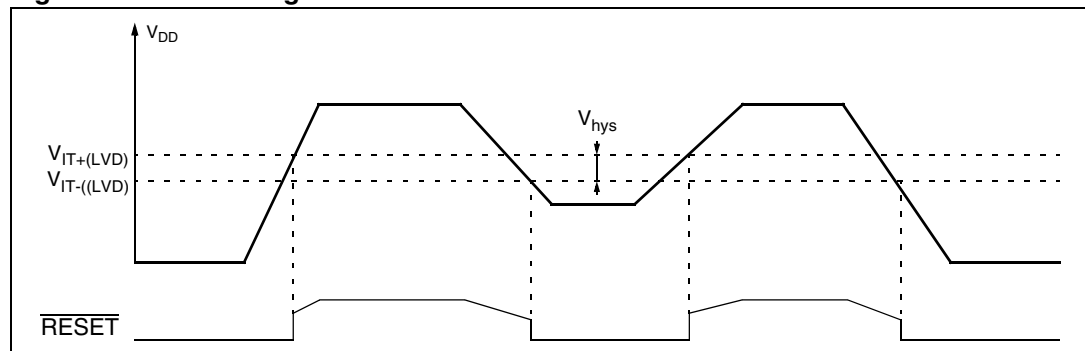

7.6.2 Auxiliary-voltage detector (AVD)

The AVD is used to provide the application with an early warning of a drop in voltage. If enabled, an interrupt can be generated allowing software to shut down safely before the LVD resets the microcontroller. See [Figure 19](#).

Note: The AVD function is active only if the LVD is enabled through the option byte (see [Section 15.1: Option bytes](#)). The activation level of the AVD is fixed at around 0.5 mV above the selected LVD threshold.

In the case of a drop in voltage below $V_{IT-(AVD)}$, the AVDF flag is set and an interrupt request is issued.

If V_{DD} rises above the $V_{IT+(AVD)}$ threshold voltage the AVDF bit is cleared automatically by hardware. No interrupt is generated, and therefore software should poll the AVDF bit to detect when the voltage has risen, and resume normal processing.

Figure 19. Using the AVD to monitor V_{DD}

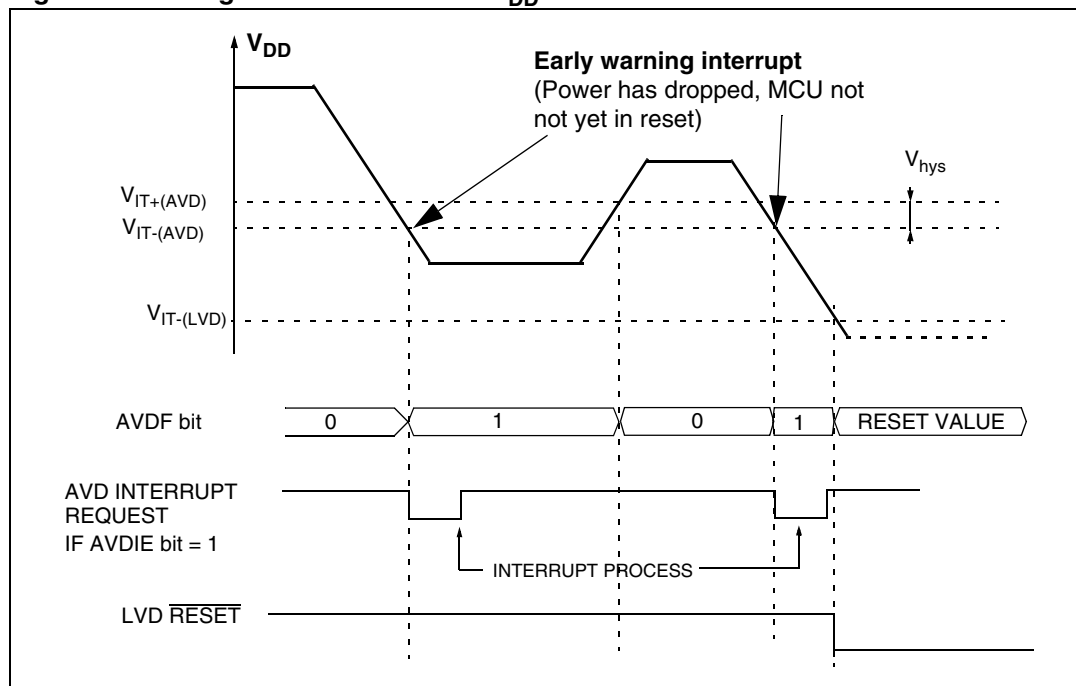

7.6.3 Low-power modes

Table 10. Low-power mode description

Mode	Description
Wait	No effect on SI. AVD interrupts cause the device to exit from Wait mode.
Halt	The SICSR register is frozen.

7.6.4 Interrupts

The AVD interrupt event generates an interrupt if the corresponding AVDIE bit is set and the interrupt mask in the CC register is reset (RIM instruction).

Table 11. Interrupt event

Interrupt event	Event flag	Enable control bit	Exit from Wait	Exit from Halt
AVD event	AVDF	AVDIE	Yes	No

7.6.5 Register description

System integrity (SI) control/status register (SICSR)

Reset value: 000x 000x (xxh)

7						0	
0	PDVDIE	AVDF	LVDRF	LOCKED	0	0	WDGRF
Read/Write							

Bit 7 = Reserved, must be kept cleared.

Bit 6 = **AVDIE** *Voltage detector interrupt enable*

This bit is set and cleared by software. It enables an interrupt to be generated when the AVDF flag goes from 0 to 1. The pending interrupt information is automatically cleared when software enters the AVD interrupt routine.

0: PDVD interrupt disabled

1: PDVD interrupt enabled

Bit 5 = **AVDF** *Voltage Detector flag*

This read-only bit is set and cleared by hardware. If the AVDIE bit is set, an interrupt request is generated when the AVDF bit goes from 0 to 1. Refer to [Figure 19](#) and to [Section 7.6.2](#) for additional details.

0: V_{DD} over $V_{IT+(AVD)}$ threshold

1: V_{DD} under $V_{IT-(AVD)}$ threshold

Bit 4 = **LVDRF** *LVD reset flag*

This bit indicates that the last Reset was generated by the LVD block. It is set by hardware (LVD reset) and cleared by software (writing zero). See WDGRF flag description for more details. When the LVD is disabled by OPTION BYTE, the LVDRF bit value is undefined.

Bit 3 = **LOCKED** *PLL Locked Flag*

This bit is set and cleared by hardware. It is set automatically when the PLL reaches its operating frequency.

0: PLL not locked

1: PLL locked

Bits 2:1 = Reserved, must be kept cleared.

Bit 0 = **WDGRF** *Watchdog reset flag*

This bit indicates that the last Reset was generated by the Watchdog peripheral. It is set by hardware (watchdog reset) and cleared by software (writing zero) or an LVD Reset (to ensure a stable cleared state of the WDGRF flag when CPU starts).

Combined with the LVDRF flag information, the flag description is given by the following table.

Table 12. LVDRF and WDGRF description

Reset sources	LVDRF	WDGRF
External $\overline{\text{RESET}}$ pin	0	0
Watchdog	0	1
LVD	1	X

Application notes

The LVDRF flag is not cleared when another reset type occurs (external or watchdog), the LVDRF flag remains set to keep trace of the original failure.
In this case, a watchdog reset can be detected by software while an external reset can not.

Caution: When the LVD is not activated with the associated option byte, the WDGRF flag can not be used in the application.

8 Interrupts

8.1 Introduction

The ST7 enhanced interrupt management provides the following features:

- Hardware interrupts
- Software interrupt (TRAP)
- Nested or concurrent interrupt management with flexible interrupt priority and level management:
 - Up to 4 software programmable nesting levels
 - Up to 16 interrupt vectors fixed by hardware
 - 2 non maskable events: reset, TRAP

This interrupt management is based on:

- Bit 5 and bit 3 of the CPU CC register (I1:0),
- Interrupt software priority registers (ISPRx),
- Fixed interrupt vector addresses located at the high addresses of the memory map (FFE0h to FFFFh) sorted by hardware priority order.

This enhanced interrupt controller guarantees full upward compatibility with the standard (not nested) ST7 interrupt controller.

8.2 Masking and processing flow

The interrupt masking is managed by the I1 and I0 bits of the CC register and the ISPRx registers which give the interrupt software priority level of each interrupt vector (see [Table 6](#)). The processing flow is shown in [Figure 20](#).

When an interrupt request has to be serviced:

- Normal processing is suspended at the end of the current instruction execution.
- The PC, X, A and CC registers are saved onto the stack.
- I1 and I0 bits of CC register are set according to the corresponding values in the ISPRx registers of the serviced interrupt vector.
- The PC is then loaded with the interrupt vector of the interrupt to service and the first instruction of the interrupt service routine is fetched (refer to “Interrupt Mapping” table for vector addresses).

The interrupt service routine should end with the IRET instruction which causes the contents of the saved registers to be recovered from the stack.

Note: As a consequence of the IRET instruction, the I1 and I0 bits will be restored from the stack and the program in the previous level will resume.

Table 13. Interrupt software priority levels

Interrupt software priority	Level	I1	I0
Level 0 (main)	Low ↓ High	1	0
Level 1		0	1
Level 2		0	0
Level 3 (= interrupt disable)		1	1

Figure 20. Interrupt processing flowchart

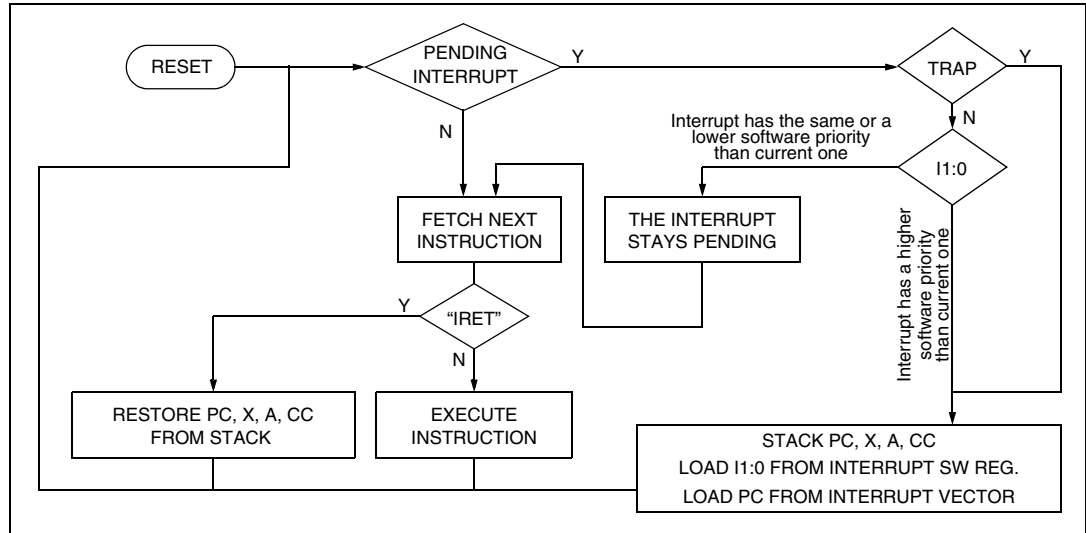

Servicing pending interrupts

As several interrupts can be pending at the same time, the interrupt to be taken into account is determined by the following two-step process:

- the highest software priority interrupt is serviced,
- if several interrupts have the same software priority, then the interrupt with the highest hardware priority is serviced first.

Figure 21 describes this decision process.

Figure 21. Priority decision process

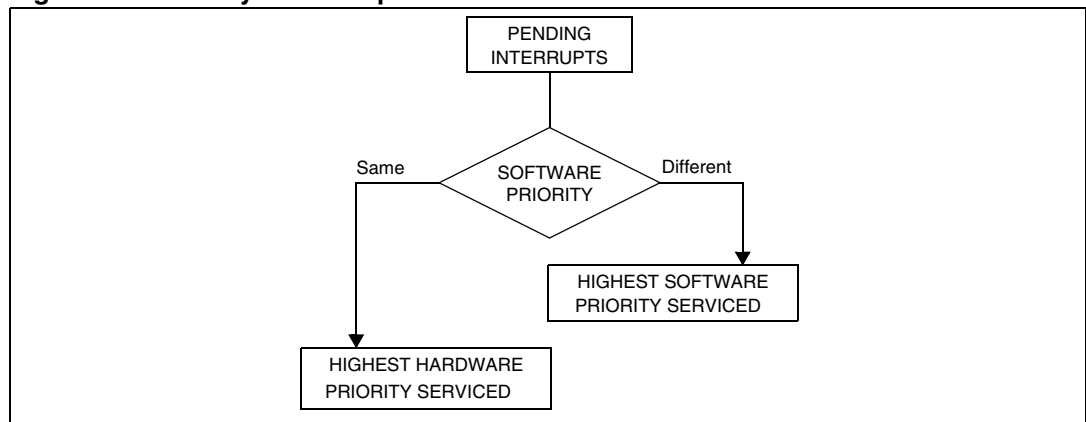

When an interrupt request is not serviced immediately, it is latched and then processed when its software priority combined with the hardware priority becomes the highest one.

- Note:
- 1 *The hardware priority is exclusive while the software one is not. This allows the previous process to succeed with only one interrupt.*
 - 2 *TLI, reset and TRAP can be considered as having the highest software priority in the decision process.*

Different interrupt vector sources

Two interrupt source types are managed by the ST7 interrupt controller: the non-maskable type (reset, TRAP) and the maskable type (external or from internal peripherals).

Non-maskable sources

These sources are processed regardless of the state of the I1 and I0 bits of the CC register (see [Figure 20](#)). After stacking the PC, X, A and CC registers (except for reset), the corresponding vector is loaded in the PC register and the I1 and I0 bits of the CC are set to disable interrupts (level 3). These sources allow the processor to exit Halt mode.

- TRAP (non-maskable software interrupt)

This software interrupt is serviced when the TRAP instruction is executed. It will be serviced according to the flowchart in [Figure 20](#).

- reset

The reset source has the highest priority in the ST7. This means that the first current routine has the highest software priority (level 3) and the highest hardware priority. See the reset chapter for more details.

Maskable sources

Maskable interrupt vector sources can be serviced if the corresponding interrupt is enabled and if its own interrupt software priority (in ISPRx registers) is higher than the one currently being serviced (I1 and I0 in CC register). If any of these two conditions is false, the interrupt is latched and thus remains pending.

- External interrupts

External interrupts allow the processor to exit from Halt low-power mode. External interrupt sensitivity is software selectable through the External Interrupt Control register (EICR).

External interrupt triggered on edge will be latched and the interrupt request automatically cleared upon entering the interrupt service routine.

If several input pins of a group connected to the same interrupt line are selected simultaneously, these will be logically ORed.

- Peripheral interrupts

Usually, the peripheral interrupts cause the MCU to exit from Halt mode except those mentioned in the “Interrupt Mapping” table. A peripheral interrupt occurs when a specific flag is set in the peripheral status registers and if the corresponding enable bit is set in the peripheral control register.

The general sequence for clearing an interrupt is based on an access to the status register followed by a read or write to an associated register.

- Note:
- The clearing sequence resets the internal latch. A pending interrupt (i.e. waiting for being serviced) will therefore be lost if the clear sequence is executed.*

8.3 Interrupts and low-power modes

All interrupts allow the processor to exit the Wait low-power mode. On the contrary, only external and other specified interrupts allow the processor to exit from the Halt modes (see column “Exit from Halt” in [Table 17: Interrupt mapping](#)). When several pending interrupts are present while exiting Halt mode, the first one serviced can only be an interrupt with exit from Halt mode capability and it is selected through the same decision process shown in [Figure 21](#).

Note: If an interrupt, that is not able to Exit from Halt mode, is pending with the highest priority when exiting Halt mode, this interrupt is serviced after the first one serviced.

8.4 Concurrent & nested management

The following [Figure 22](#) and [Figure 23](#) show two different interrupt management modes. The first is called concurrent mode and does not allow an interrupt to be interrupted, unlike the nested mode in [Figure 23](#). The interrupt hardware priority is given in this order from the lowest to the highest: MAIN, IT4, IT3, IT2, IT1, IT0, TLI. The software priority is given for each interrupt.

Warning: A stack overflow may occur without notifying the software of the failure.

Figure 22. Concurrent interrupt management

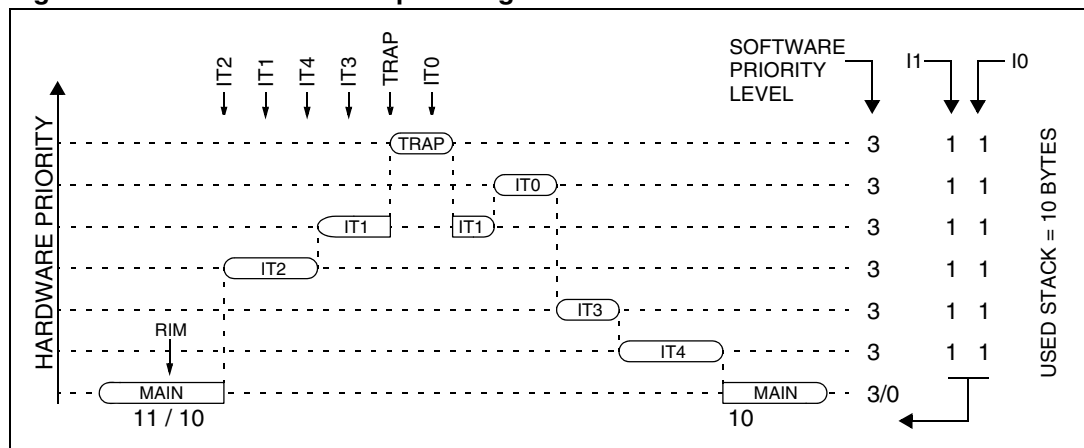
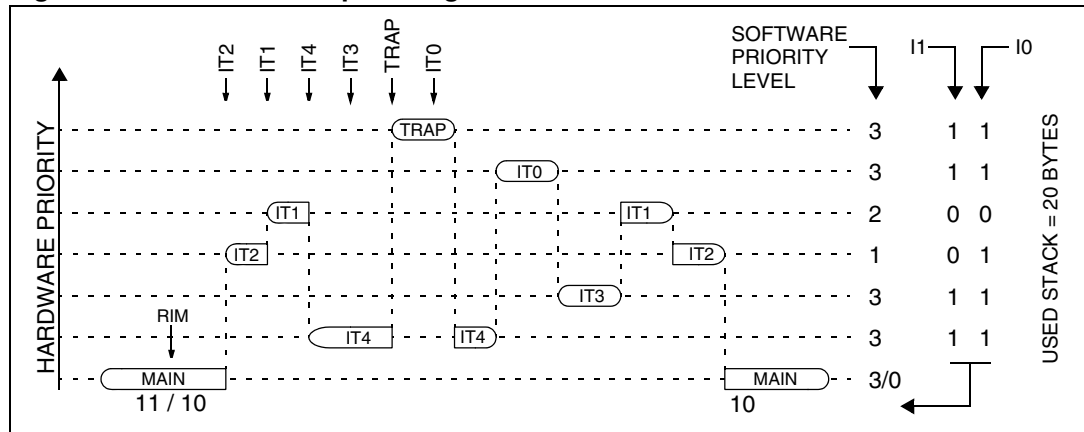

Figure 23. Nested interrupt management



8.5 Interrupt register description

8.5.1 CPU CC register interrupt bits

Reset value: 111x 1010 (xAh)

7							0
1	1	I1	H	I0	N	Z	C
Read/Write							

Bits 5, 3 = I1, I0 Software interrupt priority

These two bits indicate the current interrupt software priority.

Table 14. Interrupt software priority

Priority	Level	I1	I0
Level 0 (main)	Low ↓ High	1	0
Level 1		0	1
Level 2		0	0
Level 3 (= interrupt disable ⁽¹⁾)		1	1

1. TRAP and reset events can interrupt a level 3 program.

These two bits are set/cleared by hardware when entering in interrupt. The loaded value is given by the corresponding bits in the interrupt software priority registers (ISPRx).

They can be also set/cleared by software with the RIM, SIM, HALT, WFI, IRET and PUSH/POP instructions (see [Table 16: Dedicated interrupt instruction set](#)).

8.5.2 Interrupt software priority registers (ISPRX)

Reset value: 1111 1111 (FFh)

	7							0
ISPR0	I1_3	I0_3	I1_2	I0_2	I1_1	I0_1	I1_0	I0_0
ISPR1	I1_7	I0_7	I1_6	I0_6	I1_5	I0_5	I1_4	I0_4
ISPR2	I1_11	I0_11	I1_10	I0_10	I1_9	I0_9	I1_8	I0_8
ISPR3	1	1	1	1	I1_13	I0_13	I1_12	I0_12
Read/Write (bits 7:4 of ISPR3 are read only)								

These four registers contain the interrupt software priority of each interrupt vector.

- Each interrupt vector (except reset and TRAP) has corresponding bits in these registers where its own software priority is stored. This correspondence is shown in the following table.

Table 15. Interrupt vector addresses

Vector address	ISPRx bits
FFFBh-FFFAh	I1_0 and I0_0 bits*
FFF9h-FFF8h	I1_1 and I0_1 bits
...	...
FFE1h-FFE0h	I1_13 and I0_13 bits

- Each I1_x and I0_x bit value in the ISPRx registers has the same meaning as the I1 and I0 bits in the CC register.
- Level 0 can not be written (I1_x=1, I0_x=0). In this case, the previously stored value is kept. (example: previous = CFh, write = 64h, result = 44h)

The reset, and TRAP vectors have no software priorities. When one is serviced, the I1 and I0 bits of the CC register are both set.

Caution: If the I1_x and I0_x bits are modified while the interrupt x is executed, the following behavior has to be considered: If the interrupt x is still pending (new interrupt or flag not cleared) and the new software priority is higher than the previous one, the interrupt x is re-entered. Otherwise, the software priority stays unchanged up to the next interrupt request (after the IRET of the interrupt x).

Table 16. Dedicated interrupt instruction set

Instruction	New description	Function/example	I1	H	I0	N	Z	C
HALT	Entering Halt mode		1		0			
IRET	Interrupt routine return	Pop CC, A, X, PC	I1	H	I0	N	Z	C
JRM	Jump if I1:0=11 (level 3)	I1:0=11 ?						
JRNM	Jump if I1:0<>11	I1:0<>11 ?						
POP CC	Pop CC from the stack	Mem => CC	I1	H	I0	N	Z	C

Table 16. Dedicated interrupt instruction set (continued)

Instruction	New description	Function/example	I1	H	I0	N	Z	C
RIM	Enable interrupt (level 0 set)	Load 10 in I1:0 of CC	1		0			
SIM	Disable interrupt (level 3 set)	Load 11 in I1:0 of CC	1		1			
TRAP	Software trap	Software NMI	1		1			
WFI	Wait for interrupt		1		0			

Note: During the execution of an interrupt routine, the HALT, POPCC, RIM, SIM and WFI instructions change the current software priority up to the next IRET instruction or one of the previously mentioned instructions.

Table 17. Interrupt mapping

No.	Source block	Description	Register label	Priority order	Exit from Halt ⁽¹⁾	Address vector
	Reset	Reset	N/A	Highest priority ↓ Lowest priority	yes	FFFEh-FFFFh
	TRAP/ICD	Software or ICD interrupt			no	FFFCh-FFFDh
0	AWU	Auto wakeup interrupt	AWUCSR		yes	FFFAh-FFFBh
1	MCC/RTC	RTC time base interrupt	MCCSR		yes	FFF8h-FFF9h
2	ei0	External interrupt Port PA3, PE1	N/A		yes	FFF6h-FFF7h
3	ei1	External interrupt Port PF2:0	N/A		yes	FFF4h-FFF5h
4	ei2	External interrupt Port PB3:0	N/A		yes	FFF2h-FFF3h
5	ei3	External interrupt Port PB4	N/A		yes	FFF0h-FFF1h
6	I2C3SNS	I2C3SNS address 3 interrupt	I2C3SSR		no	FFEEh-FFEFh
7	I2C3SNS	I2C3SNS address 1 & 2 interrupt			no	FFECh-FFEDh
8	SPI	SPI peripheral interrupts	SPISR		yes ⁽²⁾	FFEAh-FFEBh
9	TIMER A	TIMER A peripheral interrupts	TASR		no	FFE8h-FFE9h
10	TIMER B	TIMER B peripheral interrupts	TBSR		no	FFE6h-FFE7h
11	SCI	SCI peripheral interrupt	SCISR	no	FFE4h-FFE5h	
12	AVD	Auxiliary-voltage-detector interrupt	SICSR	no	FFE2h-FFE3h	
13	I ² C	I ² C peripheral interrupt	I2CSRx	no	FFE0h-FFE1h	

- Valid for Halt and Active-halt modes except for the MCC/RTC interrupt source which exits from Active-halt mode only and AWU interrupt which exits from AWUFH mode only.
- Exit from Halt possible when SPI is in slave mode.

8.6 External interrupts

8.6.1 I/O port interrupt sensitivity

The external interrupt sensitivity is controlled by the IPA, IPB and ISxx bits of the EICR register (Figure 24). This control allows to have up to 4 fully independent external interrupt source sensitivities.

Each external interrupt source can be generated on four (or five) different events on the pin:

- Falling edge
- Rising edge
- Falling and rising edge
- Falling edge and low level
- Rising edge and high level (only for ei0 and ei2)

To guarantee correct functionality, the sensitivity bits in the EICR register can be modified only when the I1 and I0 bits of the CC register are both set to 1 (level 3). This means that interrupts must be disabled before changing sensitivity.

The pending interrupts are cleared by writing a different value in the ISx[1:0], IPA or IPB bits of the EICR.

Figure 24. External interrupt control bits

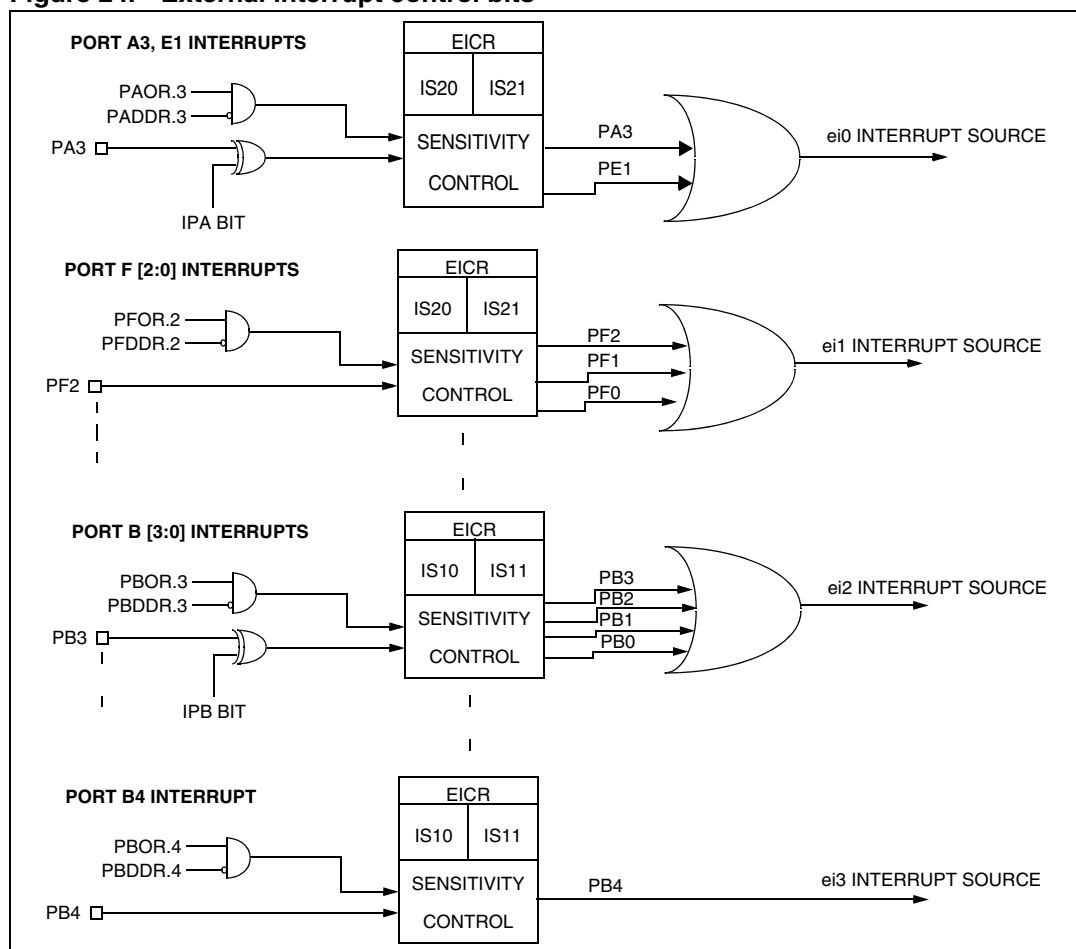

8.7 External interrupt control register (EICR)

Reset value: 0000 0000 (00h)

7							0
IS11	IS10	IPB	IS21	IS20	IPA	0	0
Read/Write							

Bits 7:6 = **IS1[1:0]** *ei2 and ei3 sensitivity*

The interrupt sensitivity, defined using the IS1[1:0] bits, is applied to the following external interrupts:

- ei2 (port B3..0)

Table 18. External interrupt sensitivity (ei2)

IS11	IS10	Sensitivity	
		IPB bit =0	IPB bit =1
0	0	Falling edge & low level	Rising edge & high level
0	1	Rising edge only	Falling edge only
1	0	Falling edge only	Rising edge only
1	1	Rising and falling edge	

- ei3 (port B4)

Table 19. External interrupt sensitivity (ei3)

IS11	IS10	Sensitivity
0	0	Falling edge & low level
0	1	Rising edge only
1	0	Falling edge only
1	1	Rising and falling edge

These 2 bits can be written only when I1 and I0 of the CC register are both set to 1 (level 3).

Bit 5 = **IPB** *Interrupt polarity for port B*

This bit is used to invert the sensitivity of the port B [3:0] external interrupts. It can be set and cleared by software only when I1 and I0 of the CC register are both set to 1 (level 3).

- 0: No sensitivity inversion
- 1: Sensitivity inversion

Bits 4:3 = **IS2[1:0]** *ei0 and ei1 sensitivity*

The interrupt sensitivity, defined using the IS2[1:0] bits, is applied to the following external interrupts:

- ei0 (port A3, port E1)

Table 20. External interrupt sensitivity (ei0)

IS21	IS20	Sensitivity	
		IPA bit =0	IPA bit =1
0	0	Falling edge & low level	Rising edge & high level
0	1	Rising edge only	Falling edge only
1	0	Falling edge only	Rising edge only
1	1	Rising and falling edge	

- ei1 (port F2..0)

Table 21. External interrupt sensitivity (ei1)

IS21	IS20	Sensitivity
0	0	Falling edge & low level
0	1	Rising edge only
1	0	Falling edge only
1	1	Rising and falling edge

These 2 bits can be written only when I1 and I0 of the CC register are both set to 1 (level 3).

Bit 2 = **IPA** *Interrupt polarity for ports A3 and E1*

This bit is used to invert the sensitivity of the port A3 and E1 external interrupts. It can be set and cleared by software only when I1 and I0 of the CC register are both set to 1 (level 3).

- 0: No sensitivity inversion
- 1: Sensitivity inversion

Bits 1:0 = Reserved, must always be kept cleared.

Table 22. Nested interrupts register map and reset values

Address (Hex.)	Register label	7	6	5	4	3	2	1	0
0024h	ISPR0 Reset value	ei1		ei0		MCC + SI		AWU	
		I1_3 1	I0_3 1	I1_2 1	I0_2 1	I1_1 1	I0_1 1	I1_0 1	I0_0 1
0025h	ISPR1 Reset value	I2C3SNS		I2C3SNS		ei3		ei2	
		I1_7 1	I0_7 1	I1_6 1	I0_6 1	I1_5 1	I0_5 1	I1_4 1	I0_4 1
0026h	ISPR2 Reset value	SCI		TIMER B		TIMER A		SPI	
		I1_11 1	I0_11 1	I1_10 1	I0_10 1	I1_9 1	I0_9 1	I1_8 1	I0_8 1
0027h	ISPR3 Reset value	1	1	1	1	I2C		AVD	
						I1_13 1	I0_13 1	I1_12 1	I0_12 1
0028h	EICR Reset value	IS11 0	IS10 0	IPB 0	IS21 0	IS20 0	IPA 0	0	0

9 Power-saving modes

9.1 Introduction

To give a large measure of flexibility to the application in terms of power consumption, five main power saving modes are implemented in the ST7 (see [Figure 25](#)):

- Slow
- Wait (and Slow-Wait)
- Active-halt
- Auto-wakeup from Halt (AWUFH)
- Halt

After a reset the normal operating mode is selected by default (Run mode). This mode drives the device (CPU and embedded peripherals) by means of a master clock which is based on the main oscillator frequency divided or multiplied by 2 (f_{OSC2}).

From Run mode, the different power saving modes may be selected by setting the relevant register bits or by calling the specific ST7 software instruction whose action depends on the oscillator status.

Figure 25. Power saving mode transitions

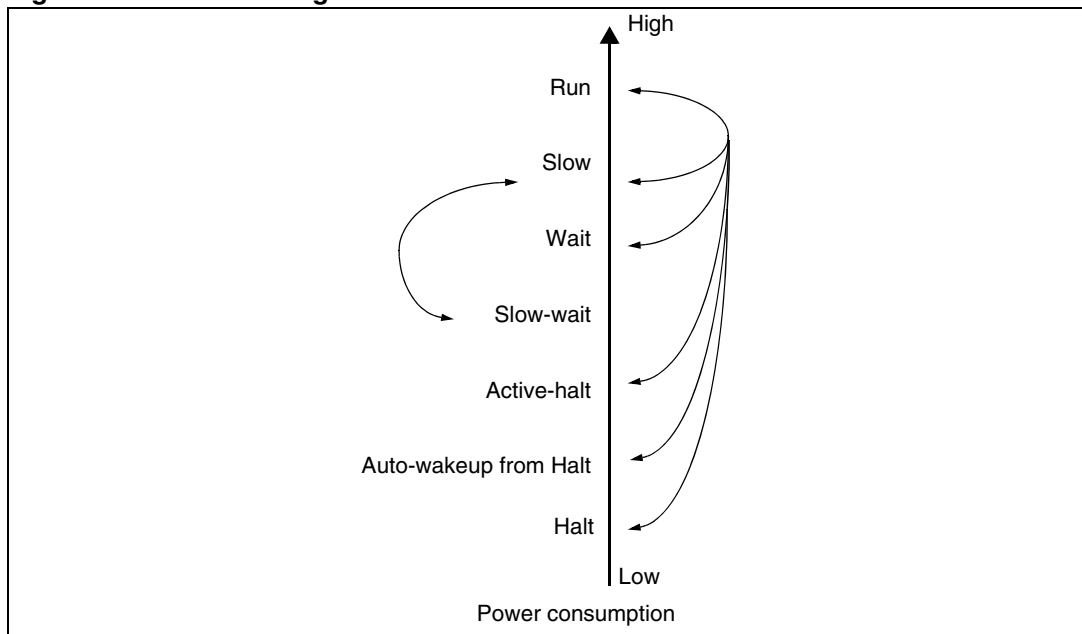

9.2 Slow mode

This mode has two targets:

- To reduce power consumption by decreasing the internal clock in the device,
- To adapt the internal clock frequency (f_{CPU}) to the available supply voltage.

Slow mode is controlled by three bits in the MCCSR register: the SMS bit which enables or disables Slow mode and two CPx bits which select the internal slow frequency (f_{CPU}).

In this mode, the master clock frequency (f_{OSC2}) can be divided by 2, 4, 8 or 16. The CPU and peripherals are clocked at this lower frequency (f_{CPU}).

Note: Slow-wait mode is activated by entering Wait mode while the device is in Slow mode.

Figure 26. Slow mode clock transitions

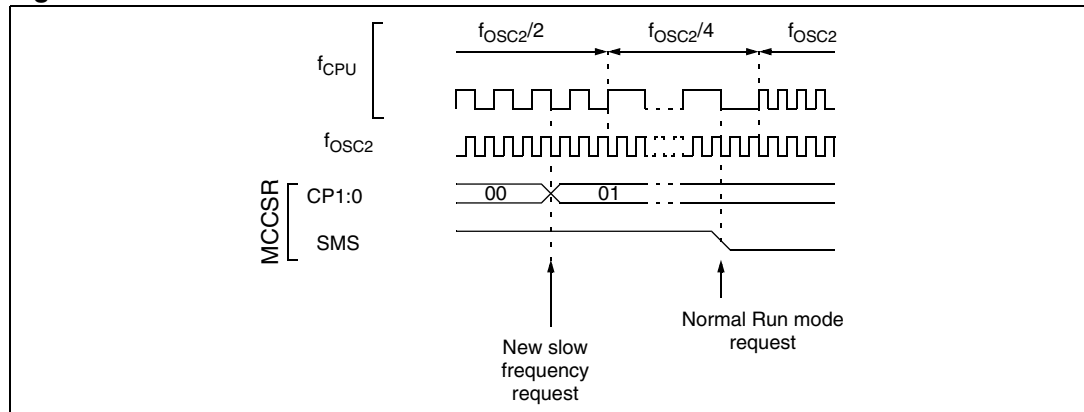

9.3 Wait mode

Wait mode places the MCU in a low-power consumption mode by stopping the CPU.

This power saving mode is selected by calling the 'WFI' instruction.

All peripherals remain active. During Wait mode, the I[1:0] bits of the CC register are forced to '10', to enable all interrupts. All other registers and memory remain unchanged. The MCU remains in Wait mode until an interrupt or reset occurs, whereupon the Program Counter branches to the starting address of the interrupt or Reset service routine.

The MCU will remain in Wait mode until a Reset or an Interrupt occurs, causing it to wake up. Refer to [Figure 27](#).

Figure 27. Wait mode flowchart

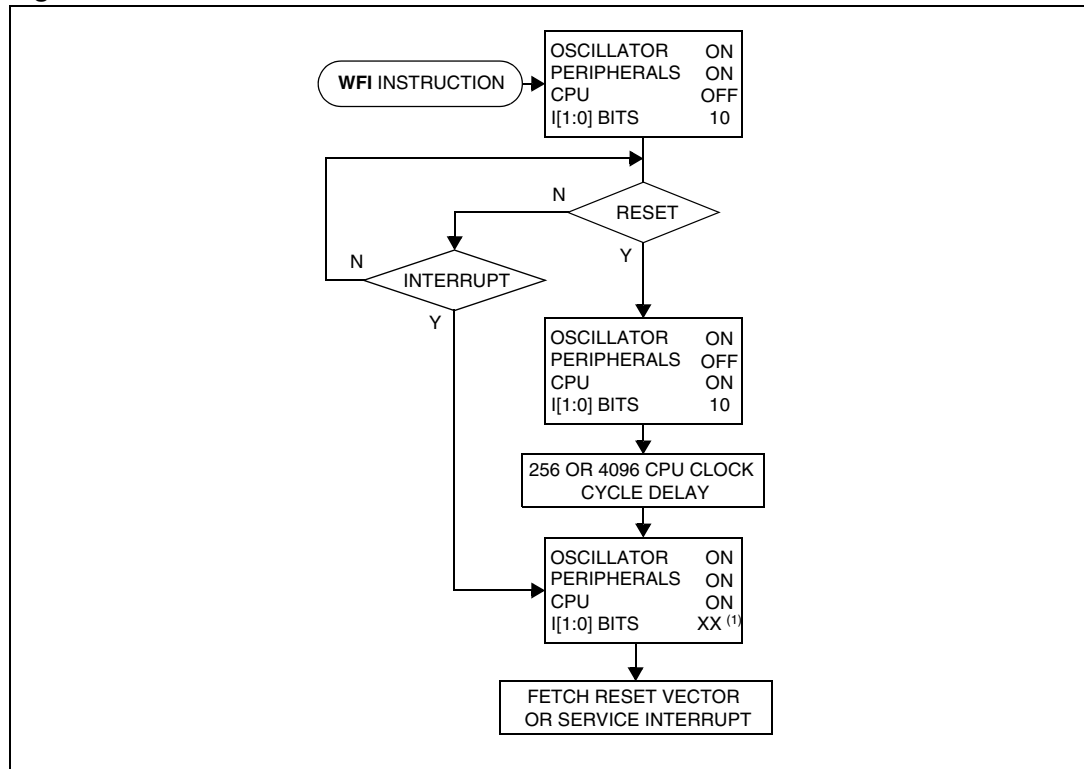

Note: Before servicing an interrupt, the CC register is pushed on the stack. The I[1:0] bits of the CC register are set to the current software priority level of the interrupt routine and recovered when the CC register is popped.

9.4 Halt mode

The Halt mode is the lowest power consumption mode of the MCU. It is entered by executing the 'HALT' instruction when the OIE bit of the Main Clock Controller Status register (MCCSR) is cleared (see [Section 11.2: Main clock controller with real-time clock and beeper \(MCC/RTC\)](#) for more details on the MCCSR register) and when the AWUEN bit in the AWUCSR register is cleared.

The MCU can exit Halt mode on reception of either a specific interrupt (see [Table 17: Interrupt mapping](#)) or a reset. When exiting Halt mode by means of a reset or an interrupt, the oscillator is immediately turned on and the 256 or 4096 CPU cycle delay is used to stabilize the oscillator. After the start up delay, the CPU resumes operation by servicing the interrupt or by fetching the reset vector which woke it up (see [Figure 29](#)).

When entering Halt mode, the I[1:0] bits in the CC register are forced to '10b' to enable interrupts. Therefore, if an interrupt is pending, the MCU wakes up immediately.

In Halt mode, the main oscillator is turned off causing all internal processing to be stopped, including the operation of the on-chip peripherals. All peripherals are not clocked except the ones which get their clock supply from another clock generator (such as an external or auxiliary oscillator).

The compatibility of Watchdog operation with Halt mode is configured by the "WDGHALT" option bit of the option byte. The HALT instruction when executed while the Watchdog

system is enabled, can generate a Watchdog reset (see [Section 11.1: Window watchdog \(WWDG\)](#) for more details).

Figure 28. Halt timing overview

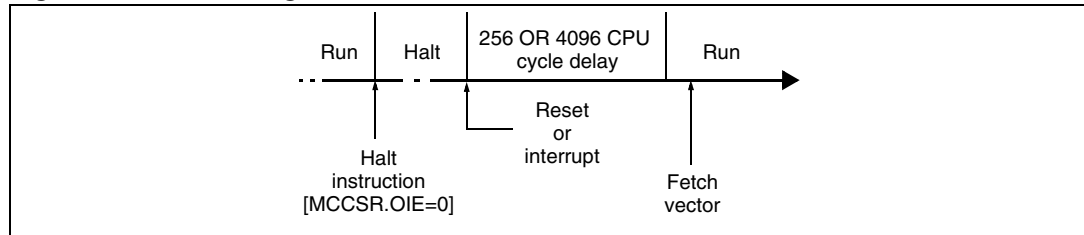
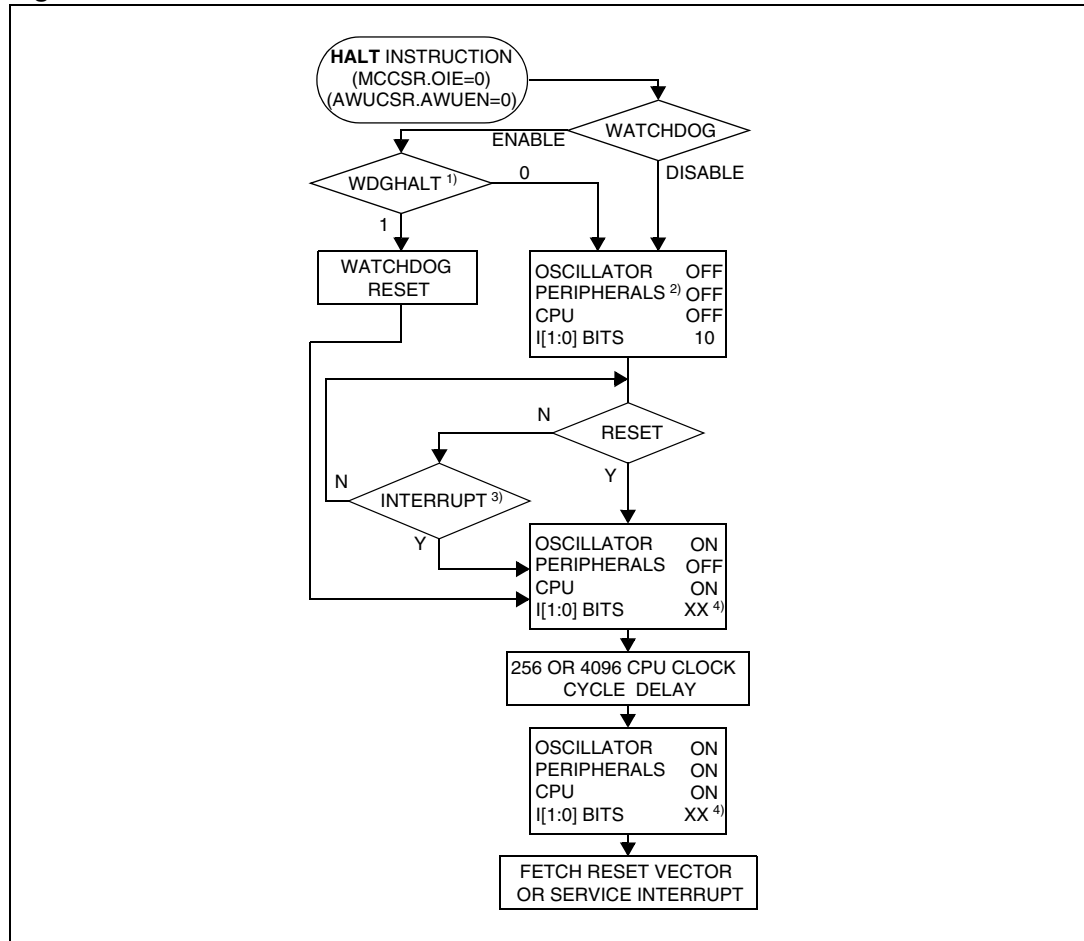

Figure 29. Halt mode flowchart



- Note:
- 1 WDGHALT is an option bit. See [Section 15.1: Option bytes](#) for more details.
 - 2 Peripheral clocked with an external clock source can still be active.
 - 3 Only some specific interrupts can exit the MCU from Halt mode (such as external interrupt). Refer to [Table 17: Interrupt mapping](#) for more details.
 - 4 Before servicing an interrupt, the CC register is pushed on the stack. The I[1:0] bits of the CC register are set to the current software priority level of the interrupt routine and recovered when the CC register is popped.

Halt mode recommendations

- Make sure that an external event is available to wake up the microcontroller from Halt mode.
- When using an external interrupt to wake up the microcontroller, reinitialize the corresponding I/O as “Input Pull-up with Interrupt” before executing the HALT instruction. The main reason for this is that the I/O may be wrongly configured due to external interference or by an unforeseen logical condition.
- For the same reason, reinitialize the level sensitiveness of each external interrupt as a precautionary measure.
- The opcode for the HALT instruction is 0x8E. To avoid an unexpected HALT instruction due to a program counter failure, it is advised to clear all occurrences of the data value 0x8E from memory. For example, avoid defining a constant in ROM with the value 0x8E.
- As the HALT instruction clears the interrupt mask in the CC register to allow interrupts, the user may choose to clear all pending interrupt bits before executing the HALT instruction. This avoids entering other peripheral interrupt routines after executing the external interrupt routine corresponding to the wake-up event (reset or external interrupt).

9.5 Active-halt mode

Active-halt mode is the lowest power consumption mode of the MCU with a real-time clock available. It is entered by executing the ‘HALT’ instruction when MCC/RTC interrupt enable flag (OIE bit in MCCR register) is set and when the AWUEN bit in the AWUCSR register is cleared (see [Section 9.7: Register description](#)).

Table 23. Power saving mode

MCCR OIE bit	Power saving mode entered when HALT instruction is executed
0	Halt mode
1	Active-halt mode

The MCU can exit Active-halt mode on reception of the RTC interrupt and some specific interrupts (see [Table 17: Interrupt mapping](#)) or a reset. When exiting Active-halt mode by means of a reset a 4096 or 256 CPU cycle delay occurs (depending on the option byte). After the start up delay, the CPU resumes operation by servicing the interrupt or by fetching the reset vector which woke it up (see [Figure 31](#)).

When entering Active-halt mode, the I[1:0] bits in the CC register are cleared to enable interrupts. Therefore, if an interrupt is pending, the MCU wakes up immediately.

In Active-Halt mode, only the main oscillator and its associated counter (MCC/RTC) are running to keep a wake-up time base. All other peripherals are not clocked except those which get their clock supply from another clock generator (such as external or auxiliary oscillator).

The safeguard against staying locked in Active-halt mode is provided by the oscillator interrupt.

Note: As soon as active halt is enabled, executing a HALT instruction while the Watchdog is active does not generate a reset. This means that the device cannot spend more than a defined delay in this power saving mode.

Figure 30. Active-halt timing overview

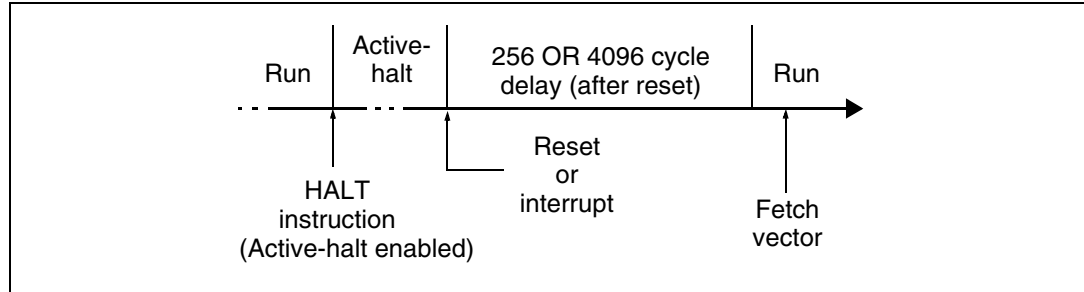
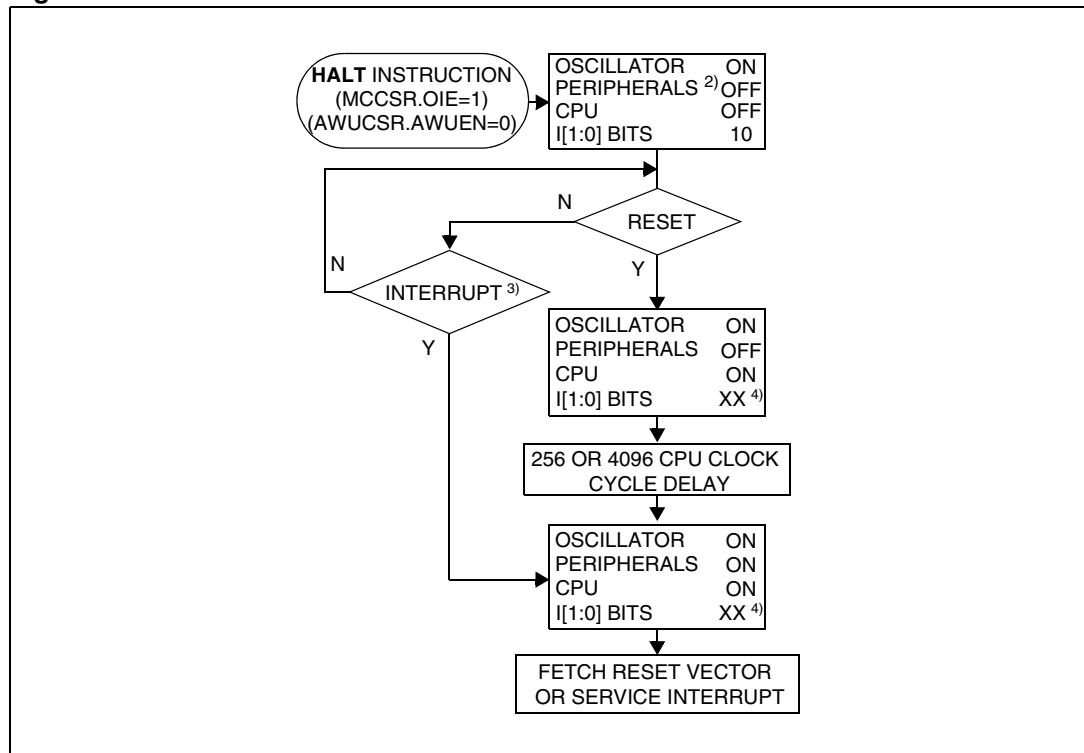

Figure 31. Active-halt mode flowchart



- Note:
- 1 This delay occurs only if the MCU exits Active-Halt mode by means of a reset.
 - 2 Peripheral clocked with an external clock source can still be active.
 - 3 Only the RTC interrupt and some specific interrupts can exit the MCU from Active-halt mode (such as external interrupt). Refer to [Table 17](#) for more details.
 - 4 Before servicing an interrupt, the CC register is pushed on the stack. The I[1:0] bits in the CC register are set to the current software priority level of the interrupt routine and restored when the CC register is popped.

9.6 Auto-wakeup from Halt mode

Auto-wakeup from Halt (AWUFH) mode is similar to Halt mode with the addition of an internal RC oscillator for wake-up. Compared to Active-Halt mode, AWUFH has lower power consumption because the main clock is not kept running, but there is no accurate real-time clock available.

It is entered by executing the HALT instruction when the AWUEN bit in the AWUCSR register has been set and the OIE bit in the MCCR register is cleared (see [Section 11.2: Main clock controller with real-time clock and beeper \(MCC/RTC\)](#) for more details).

Figure 32. AWUFH mode block diagram

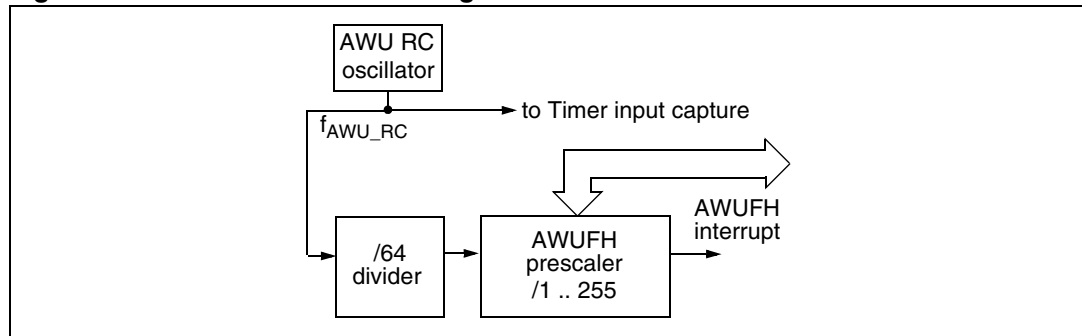

As soon as Halt mode is entered, and if the AWUEN bit has been set in the AWUCSR register, the AWU RC oscillator provides a clock signal (f_{AWU_RC}). Its frequency is divided by a fixed divider and a programmable prescaler controlled by the AWUPR register. The output of this prescaler provides the delay time. When the delay has elapsed the AWUF flag is set by hardware and an interrupt wakes-up the MCU from Halt mode. At the same time the main oscillator is immediately turned on and a 256 or 4096 cycle delay is used to stabilize it. After this startup delay, the CPU resumes operation by servicing the AWUFH interrupt. The AWU flag and its associated interrupt are cleared by software reading the AWUCSR register.

To compensate for any frequency dispersion of the AWU RC oscillator, it can be calibrated by measuring the clock frequency f_{AWU_RC} and then calculating the right prescaler value. Measurement mode is enabled by setting the AWUM bit in the AWUCSR register in Run mode. This connects internally f_{AWU_RC} to the ICAP2 input of the 16-bit timer A, allowing the f_{AWU_RC} to be measured using the main oscillator clock as a reference timebase.

Similarities with Halt mode

The following AWUFH mode behavior is the same as normal Halt mode:

- The MCU can exit AWUFH mode by means of any interrupt with exit from Halt capability or a reset (see [Section 9.4: Halt mode](#)).
- When entering AWUFH mode, the I[1:0] bits in the CC register are forced to 10b to enable interrupts. Therefore, if an interrupt is pending, the MCU wakes up immediately.
- In AWUFH mode, the main oscillator is turned off causing all internal processing to be stopped, including the operation of the on-chip peripherals. None of the peripherals are clocked except those which get their clock supply from another clock generator (such as an external or auxiliary oscillator like the AWU oscillator).
- The compatibility of the Watchdog operation with the AWUFH mode is configured by the WDGHALT option bit in the option byte. Depending on this setting, the HALT instruction, when executed while the Watchdog system is enabled, can generate a Watchdog reset.

Figure 33. AWUF Halt timing diagram

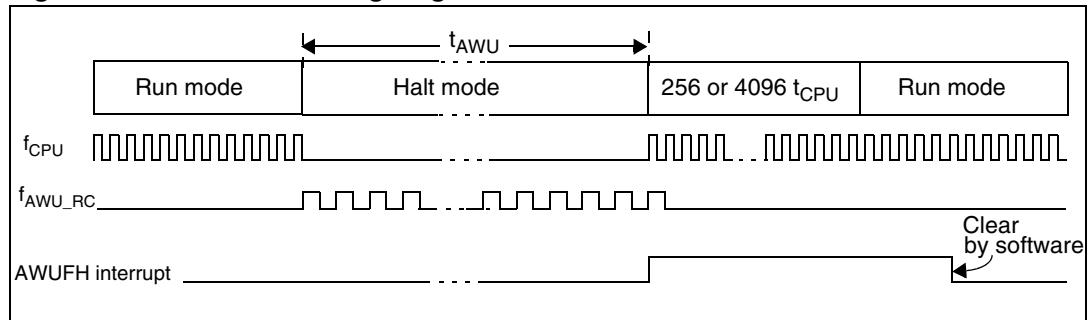
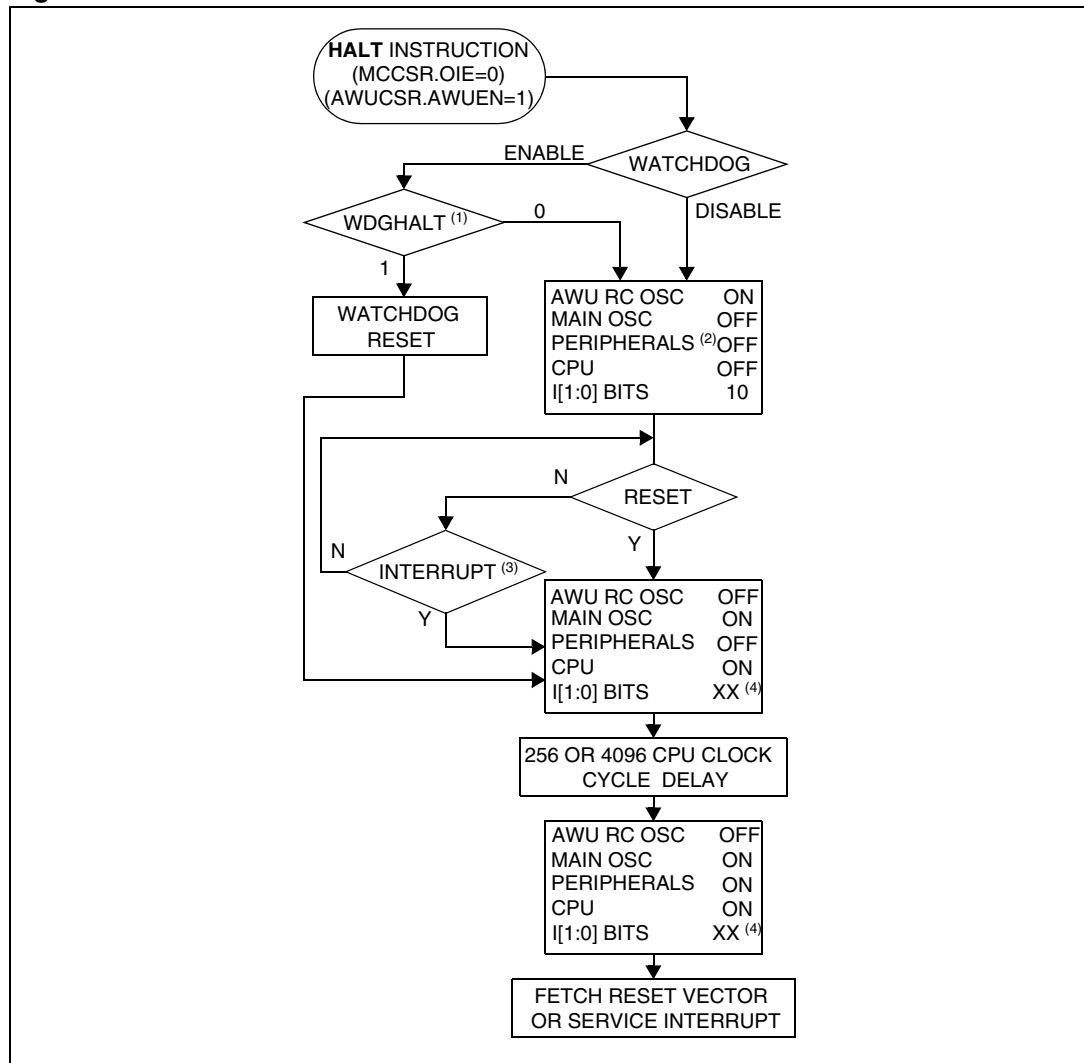

Figure 34. AWUFH mode flowchart



1. WDGHALT is an option bit. See [Section 15.1: Option bytes](#) for more details.
2. Peripheral clocked with an external clock source can still be active.
3. Only an AWUFH interrupt and some specific interrupts can exit the MCU from Halt mode (such as external interrupt). Refer to [Table 17: Interrupt mapping](#) for more details.
4. Before servicing an interrupt, the CC register is pushed on the stack. The I[1:0] bits of the CC register are set to the current software priority level of the interrupt routine and recovered when the CC register is popped.

9.7 Register description

9.7.1 AWUFH control/status register (AWUCSR)

Reset value: 0000 0000 (00h)

7						0
0	0	0	0	0	AWU F	AWUM AWUEN
Read/Write (except bit 2 read only)						

Bits 7:3 = Reserved.

Bit 2= **AWUF** *Auto-wakeup flag*

This bit is set by hardware when the AWU module generates an interrupt and cleared by software on reading AWUCSR.

0: No AWU interrupt occurred

1: AWU interrupt occurred

Bit 1= **AWUM** *Auto-wakeup measurement*

This bit enables the AWU RC oscillator and connects internally its output to the ICAP2 input of 16-bit timer A. This allows the timer to be used to measure the AWU RC oscillator dispersion and then compensate this dispersion by providing the right value in the AWUPR register.

0: Measurement disabled

1: Measurement enabled

Bit 0 = **AWUEN** *Auto-wakeup from Halt Enabled*

This bit enables the Auto-wakeup from Halt feature: once Halt mode is entered, the AWUFH wakes up the microcontroller after a time delay defined by the AWU prescaler value. It is set and cleared by software.

0: AWUFH (Auto-wakeup from Halt) mode disabled

1: AWUFH (Auto-wakeup from Halt) mode enabled

9.7.2 AWUFH prescaler register (AWUPR)

Reset value: 1111 1111 (FFh)

7									0
AWUPR7	AWUPR6	AWUPR5	AWUPR4	AWUPR3	AWUPR2	AWUPR1	AWUPR0		
Read/Write									

Bits 7:0= **AWUPR[7:0]** *Auto-wakeup Prescaler*

These 8 bits define the AWUPR Dividing factor, as explained below:

Table 24. AWUPR dividing factor

AWUPR[7:0]	Dividing factor
00h	Forbidden ⁽¹⁾
01h	1
...	...
FEh	254
FFh	255

1. If 00h is written to AWUPR, depending on the product, an interrupt is generated immediately after a HALT instruction, or the AWUPR remains unchanged.

In AWU mode, the period that the MCU stays in Halt mode (t_{AWU} in [Figure 33](#)) is defined by

$$t_{AWU} = 64 \times AWUPR \times \frac{1}{f_{AWURC}} + t_{RCSTRT}$$

This prescaler register can be programmed to modify the time that the MCU stays in Halt mode before waking up automatically.

Table 25. AWU register map and reset values

Address (Hex.)	Register label	7	6	5	4	3	2	1	0
002Eh	AWUCSR Reset value	0	0	0	0	0	AWUF 0	AWUM 0	AWUEN 0
002Fh	AWUPR Reset value	AWUPR7 1	AWUPR6 1	AWUPR5 1	AWUPR4 1	AWUPR3 1	AWUPR2 1	AWUPR1 1	AWUPR0 1

10 I/O ports

10.1 Introduction

The I/O ports offer different functional modes:

- transfer of data through digital inputs and outputs

and for specific pins:

- external interrupt generation
- alternate signal input/output for the on-chip peripherals.

An I/O port contains up to 8 pins. Each pin can be programmed independently as digital input (with or without interrupt generation) or digital output.

10.2 Functional description

Each port has two main registers:

- Data Register (DR)
- Data Direction Register (DDR)

and one optional register:

- Option Register (OR)

Each I/O pin may be programmed using the corresponding register bits in the DDR and OR registers: Bit X corresponding to pin X of the port. The same correspondence is used for the DR register.

The following description takes into account the OR register. (For specific ports which do not provide this register, refer to the I/O Port Implementation section). The generic I/O block diagram is shown in [Figure 35](#).

10.2.1 Input modes

The input configuration is selected by clearing the corresponding DDR register bit. In this case, reading the DR register returns the digital value applied to the external I/O pin. Different input modes can be selected by software through the OR register.

- Note:*
- 1 *Writing the DR register modifies the latch value but does not affect the pin status.*
 - 2 *When switching from input to output mode, the DR register has to be written first to drive the correct level on the pin as soon as the port is configured as an output.*
 - 3 *Do not use read/modify/write instructions (BSET or BRES) to modify the DR register as this might corrupt the DR content for I/Os configured as input.*

External interrupt function

When an I/O is configured as Input with Interrupt, an event on this I/O can generate an external interrupt request to the CPU.

Each pin can independently generate an interrupt request. The interrupt sensitivity is independently programmable using the sensitivity bits in the EICR register.

Each external interrupt vector is linked to a dedicated group of I/O port pins (see [Section 2: Pin description](#) and [Section 8: Interrupts](#)). If several input pins are selected simultaneously as interrupt sources, these are first detected according to the sensitivity bits in the EICR register and then logically ORed.

The external interrupts are hardware interrupts, which means that the request latch (not accessible directly by the application) is automatically cleared when the corresponding interrupt vector is fetched. To clear an unwanted pending interrupt by software, the sensitivity bits in the EICR register must be modified.

10.2.2 Output modes

The output configuration is selected by setting the corresponding DDR register bit. In this case, writing the DR register applies this digital value to the I/O pin through the latch. Then reading the DR register returns the previously stored value.

Two different output modes can be selected by software through the OR register: Output push-pull and open-drain. DR register value and output pin status are described below:

Table 26. Output modes

DR	Push-pull	Open-drain
0	V _{SS}	V _{SS}
1	V _{DD}	Floating

10.2.3 Alternate functions

When an on-chip peripheral is configured to use a pin, the alternate function is automatically selected. This alternate function takes priority over the standard I/O programming.

When the signal is coming from an on-chip peripheral, the I/O pin is automatically configured in output mode (push-pull or open drain according to the peripheral).

When the signal is going to an on-chip peripheral, the I/O pin must be configured in input mode. In this case, the pin state is also digitally readable by addressing the DR register.

Note: Input pull-up configuration can cause unexpected value at the input of the alternate peripheral input. When an on-chip peripheral uses a pin as input and output, this pin has to be configured in input floating mode.

Figure 35. I/O port general block diagram

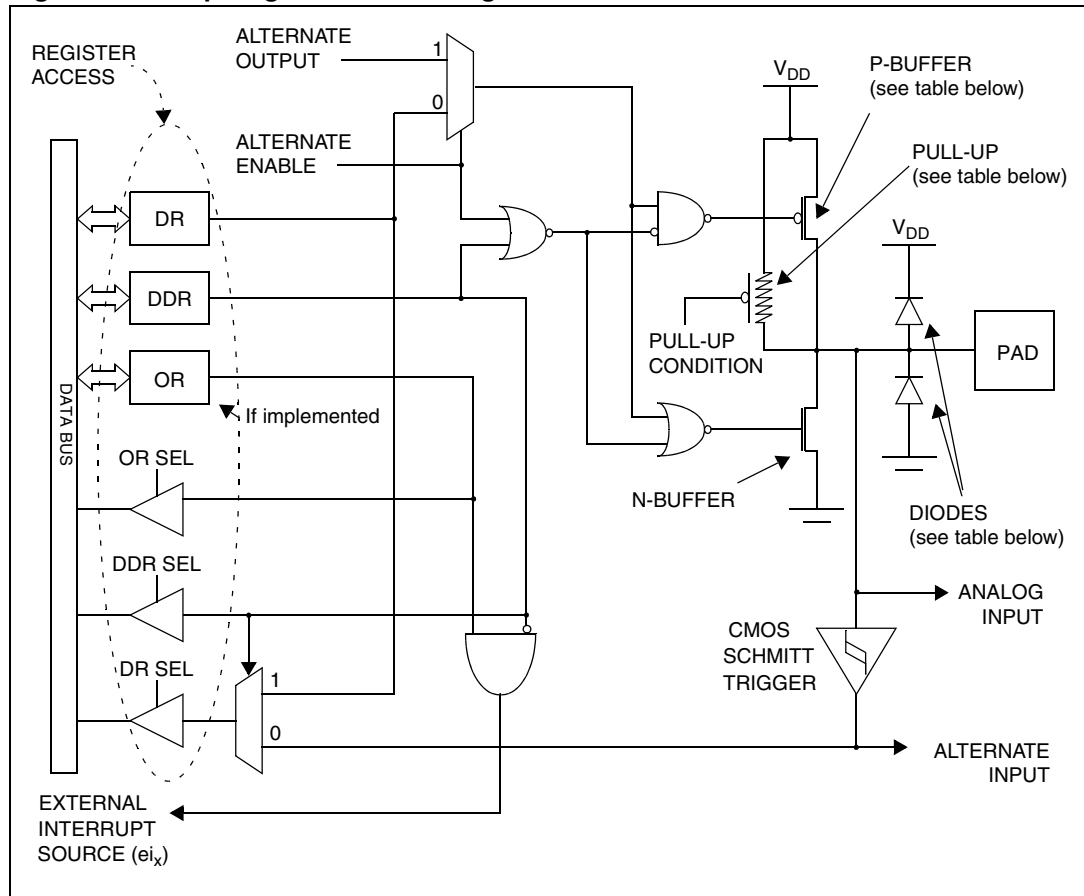

Table 27. I/O Port mode options⁽¹⁾

Configuration mode		Pull-up	P-Buffer	Diodes	
				to V _{DD}	to V _{SS}
Input	Floating with/without Interrupt	Off	Off	On	On
	Pull-up with/without Interrupt	On			
Output	Push-pull	Off	On	On	On
	Open drain (logic level)		Off		
	True open drain	NI	NI	NI ⁽²⁾	

1. NI = not implemented, Off = implemented not activated, On = implemented and activated.

2. The diode to V_{DD} is not implemented in the true open drain pads. A local protection between the pad and V_{SS} is implemented to protect the device against positive stress.

Table 28. I/O port configurations

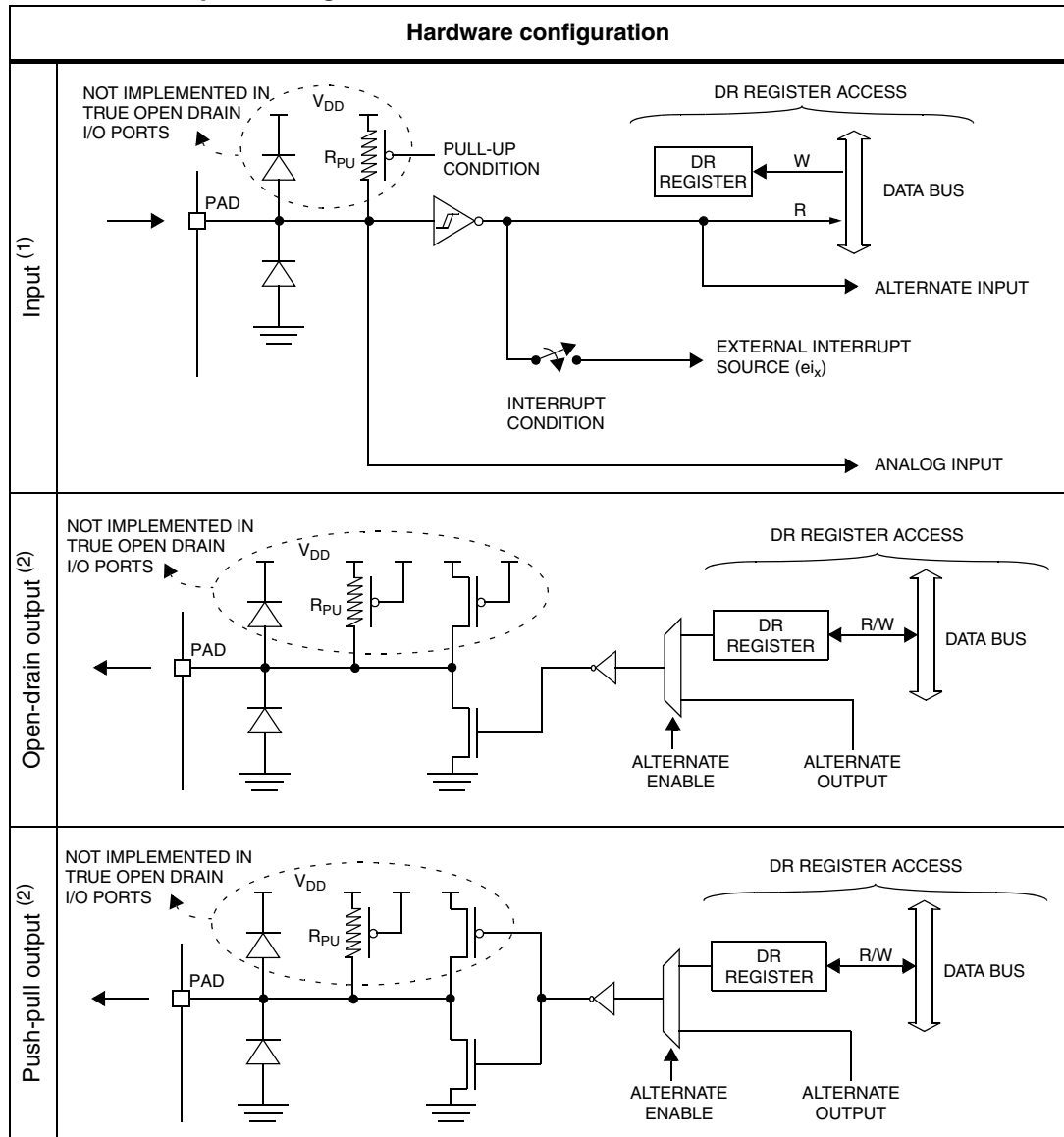

1. When the I/O port is in input configuration and the associated alternate function is enabled as an output, reading the DR register will read the alternate function output status.
2. When the I/O port is in output configuration and the associated alternate function is enabled as an input, the alternate function reads the pin status given by the DR register content.

Caution: The alternate function must not be activated as long as the pin is configured as input with interrupt, in order to avoid generating spurious interrupts.

Analog alternate function

When the pin is used as an ADC input, the I/O must be configured as floating input. The analog multiplexer (controlled by the ADC registers) switches the analog voltage present on the selected pin to the common analog rail which is connected to the ADC input.

It is recommended not to change the voltage level or loading on any port pin while conversion is in progress. Furthermore, it is recommended not to have clocking pins located close to a selected analog pin.

Warning: The analog input voltage level must be within the limits stated in the absolute maximum ratings.

10.3 I/O port implementation

The hardware implementation on each I/O port depends on the settings in the DDR and OR registers and specific feature of the I/O port such as ADC Input or true open drain.

Switching these I/O ports from one state to another should be done in a sequence that prevents unwanted side effects. Recommended safe transitions are illustrated in [Figure 36](#). Other transitions are potentially risky and should be avoided, since they are likely to present unwanted side-effects such as spurious interrupt generation.

Figure 36. Interrupt I/O port state transitions

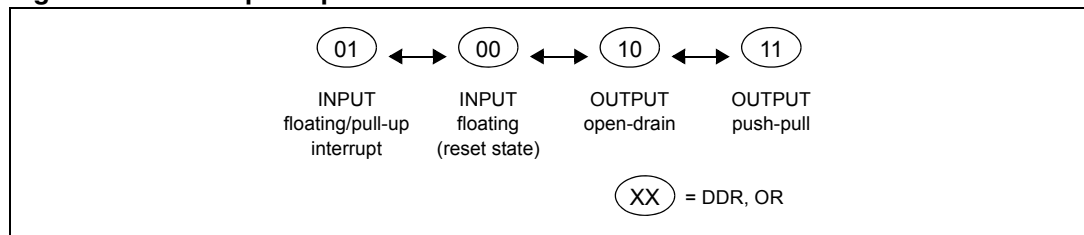

10.4 Low-power modes

Table 29. Description

Mode	Description
Wait	No effect on I/O ports. External interrupts cause the device to exit from Wait mode.
Halt	No effect on I/O ports. External interrupts cause the device to exit from Halt mode.

10.5 Interrupts

The external interrupt event generates an interrupt if the corresponding configuration is selected with DDR and OR registers and the interrupt mask in the CC register is not active (RIM instruction).

Table 30. Description of interrupt events

Interrupt event	Event flag	Enable Control bit	Exit from Wait	Exit from Halt
External interrupt on selected external event	-	DDRx ORx	Yes	

10.5.1 I/O port implementation

The I/O port register configurations are summarized as follows.

Standard ports: PA[5:4], PC[7:0], PD[5:0], PE0, PF[7:6], PF4

Table 31. I/O port register configurations (standard ports)

Mode	DDR	OR
floating input	0	0
pull-up input	0	1
open drain output	1	0
push-pull output	1	1

Interrupt ports: PB4, PB[2:0], PF[1:0] (with pull-up)

Table 32. I/O port register configurations (interrupt ports with pull-up)

Mode	DDR	OR
floating input	0	0
pull-up interrupt input	0	1
open drain output	1	0
push-pull output	1	1

PA3, PE1, PB3, PF2 (without pull-up)

Table 33. I/O port register configurations (interrupt ports without pull-up)

Mode	DDR	OR
floating input	0	0
floating interrupt input	0	1
open drain output	1	0
push-pull output	1	1

True open-drain ports: PA[7:6], PD[7:6]

Table 34. I/O port register configurations (true open drain ports)

Mode	DDR
floating input	0
open drain (high sink ports)	1

Table 35. Port configuration

Port	Pin name	Input		Output	
		OR = 0	OR = 1	OR = 0	OR = 1
Port A	PA7:6	floating		true open-drain	
	PA5:4	floating	pull-up	open drain	push-pull
	PA3	floating	floating interrupt	open drain	push-pull
Port B	PB3	floating	floating interrupt	open drain	push-pull
	PB4, PB2:0	floating	pull-up interrupt	open drain	push-pull
Port C	PC7:0	floating	pull-up	open drain	push-pull
Port D	PD7:6	floating		true open-drain	
	PD5:0	floating	pull-up	open drain	push-pull
Port E	PE1	floating	floating interrupt	open drain	push-pull
	PE0	floating	pull-up	open drain	push-pull
Port F	PF7:6, 4	floating	pull-up	open drain	push-pull
	PF2	floating	floating interrupt	open drain	push-pull
	PF1:0	floating	pull-up interrupt	open drain	push-pull

Caution: In small packages, an internal pull-up is applied permanently to the non-bonded I/O pins. So they have to be kept in input floating configuration to avoid unwanted consumption.

Table 36. I/O port register map and reset values

Address (Hex.)	Register label	7	6	5	4	3	2	1	0
Reset value of all I/O port registers		0	0	0	0	0	0	0	0
0000h	PADR	MSB							LSB
0001h	PADDR								
0002h	PAOR								
0003h	PBDR	MSB							LSB
0004h	PBDDR								
0005h	PBOR								
0006h	PCDR	MSB							LSB
0007h	PCDDR								
0008h	PCOR								
0009h	PDDR	MSB							LSB
000Ah	PDDDR								
000Bh	PDOR								

Table 36. I/O port register map and reset values (continued)

Address (Hex.)	Register label	7	6	5	4	3	2	1	0
000Ch	PEDR	MSB							LSB
000Dh	PEDDR								
000Eh	PEOR								
000Fh	PFDR	MSB							LSB
0010h	PFDDR								
0011h	PFOR								

11 On-chip peripherals

11.1 Window watchdog (WWDG)

11.1.1 Introduction

The window watchdog is used to detect the occurrence of a software fault, usually generated by external interference or by unforeseen logical conditions, which causes the application program to abandon its normal sequence. The Watchdog circuit generates an MCU reset on expiry of a programmed time period, unless the program refreshes the contents of the downcounter before the T6 bit becomes cleared. An MCU reset is also generated if the 7-bit downcounter value (in the control register) is refreshed before the downcounter has reached the window register value. This implies that the counter must be refreshed in a limited window.

11.1.2 Main features

- Programmable free-running downcounter
- Conditional reset
 - Reset (if watchdog activated) when the downcounter value becomes less than 40h
 - Reset (if watchdog activated) if the downcounter is reloaded outside the window (see [Figure 40](#))
- Hardware/Software Watchdog activation (selectable by option byte)
- Optional reset on HALT instruction (configurable by option byte)

11.1.3 Functional description

The counter value stored in the WDGCR register (bits T[6:0]), is decremented every $16384 f_{OSC2}$ cycles (approx.), and the length of the timeout period can be programmed by the user in 64 increments.

If the watchdog is activated (the WDGA bit is set) and when the 7-bit downcounter (T[6:0] bits) rolls over from 40h to 3Fh (T6 becomes cleared), it initiates a reset cycle pulling low the reset pin for typically 30 μ s. If the software reloads the counter while the counter is greater than the value stored in the window register, then a reset is generated.

Figure 37. Watchdog block diagram

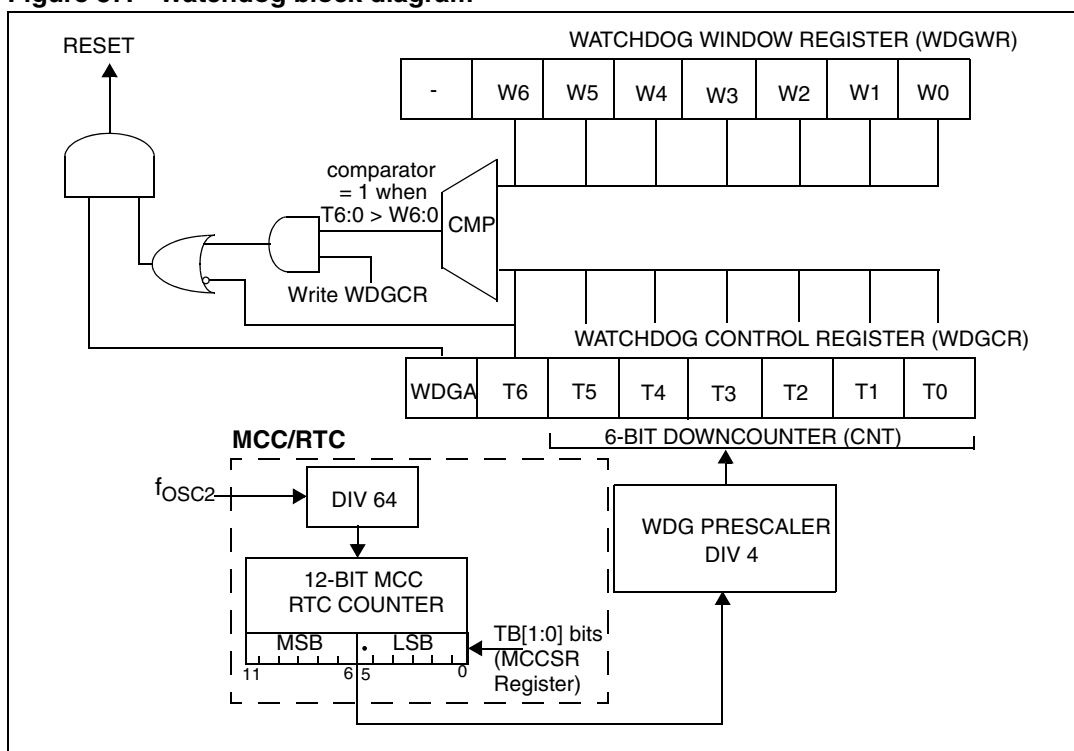

The application program must write in the WDGCR register at regular intervals during normal operation to prevent an MCU reset. This operation must occur only when the counter value is lower than the window register value. The value to be stored in the WDGCR register must be between FFh and C0h (see [Figure 38: Approximate timeout duration](#)):

- **Enabling the watchdog:**
 When Software Watchdog is selected (by option byte), the watchdog is disabled after a reset. It is enabled by setting the WDGA bit in the WDGCR register, then it cannot be disabled again except by a reset.
 When Hardware Watchdog is selected (by option byte), the watchdog is always active and the WDGA bit is not used.
- **Controlling the downcounter:**
 This downcounter is free-running: It counts down even if the watchdog is disabled. When the watchdog is enabled, the T6 bit must be set to prevent generating an immediate reset.
 The T[5:0] bits contain the number of increments which represents the time delay before the watchdog produces a reset (see [Figure 38](#)). The timing varies between a minimum and a maximum value due to the unknown status of the prescaler when writing to the WDGCR register (see [Figure 39: Exact timeout duration \(\$t_{min}\$ and \$t_{max}\$ \)](#)).
 The window register (WDGWR) contains the high limit of the window: To prevent a reset, the downcounter must be reloaded when its value is lower than the window register value and greater than 3Fh. [Figure 40: Window watchdog timing diagram](#) describes the window watchdog process.

Note: The T6 bit can be used to generate a software reset (the WDGA bit is set and the T6 bit is cleared).

- Watchdog reset on Halt option
 If the watchdog is activated and the watchdog reset on halt option is selected, then the HALT instruction will generate a Reset.

11.1.4 Using Halt mode with the WDG

If Halt mode with Watchdog is enabled by option byte (no watchdog reset on HALT instruction), it is recommended before executing the HALT instruction to refresh the WDG counter, to avoid an unexpected WDG reset immediately after waking up the microcontroller.

11.1.5 How to program the watchdog timeout

Figure 38 shows the linear relationship between the 6-bit value to be loaded in the watchdog counter (CNT) and the resulting timeout duration in milliseconds. This can be used for a quick calculation without taking the timing variations into account. If more precision is needed, use the formulae in Figure 39.

Caution: When writing to the WDGCR register, always write 1 in the T6 bit to avoid generating an immediate reset.

Figure 38. Approximate timeout duration

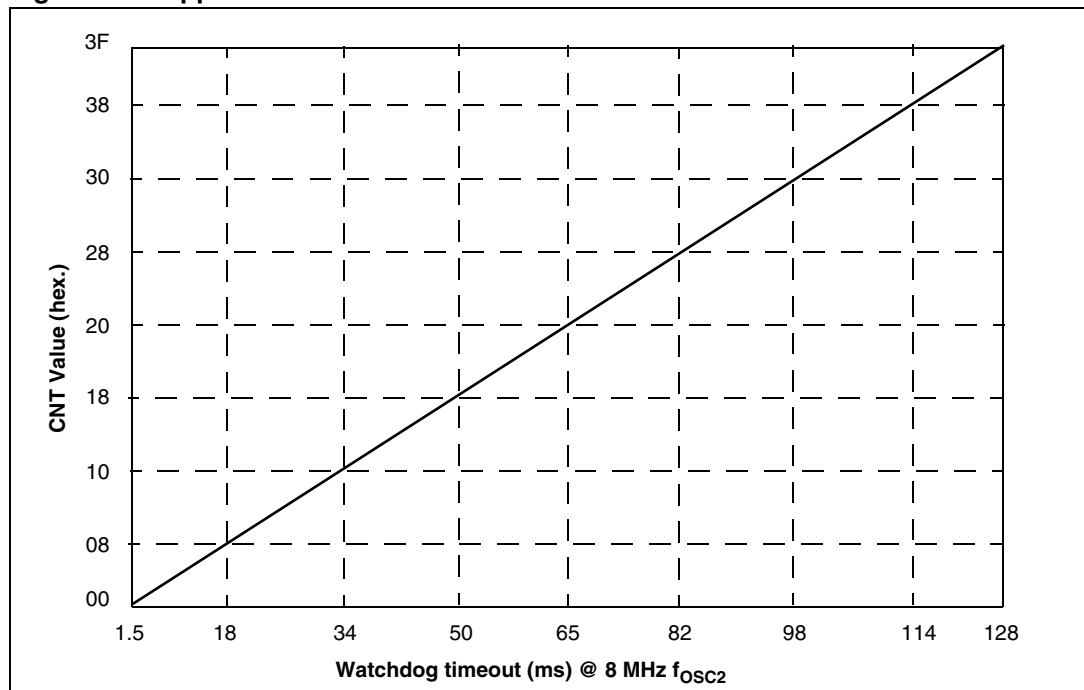

Figure 39. Exact timeout duration (t_{min} and t_{max})

Where:

$$t_{min0} = (LSB + 128) \times 64 \times t_{OSC2}$$

$$t_{max0} = 16384 \times t_{OSC2}$$

$$t_{OSC2} = 125 \text{ ns if } f_{OSC2} = 8 \text{ MHz}$$

CNT = Value of T[5:0] bits in the WDGCR register (6 bits)

MSB and LSB are values from the table below depending on the timebase selected by the TB[1:0] bits in the MCCSR register

TB1 bit (MCCSR Reg.)	TB0 bit (MCCSR Reg.)	Selected MCCSR time base	MSB	LSB
0	0	2 ms	4	59
0	1	4 ms	8	53
1	0	10 ms	20	35
1	1	25 ms	49	54

To calculate the minimum watchdog timeout (t_{min}):

$$\text{If } CNT < \left\lfloor \frac{MSB}{4} \right\rfloor \text{ then } t_{min} = t_{min0} + 16384 \times CNT \times t_{osc2}$$

$$\text{else } t_{min} = t_{min0} + \left[16384 \times \left(CNT - \left\lfloor \frac{4CNT}{MSB} \right\rfloor \right) + (192 + LSB) \times 64 \times \left\lfloor \frac{4CNT}{MSB} \right\rfloor \right] \times t_{osc2}$$

To calculate the maximum Watchdog Timeout (t_{max}):

$$\text{If } CNT \leq \left\lfloor \frac{MSB}{4} \right\rfloor \text{ then } t_{max} = t_{max0} + 16384 \times CNT \times t_{osc2}$$

$$\text{else } t_{max} = t_{max0} + \left[16384 \times \left(CNT - \left\lfloor \frac{4CNT}{MSB} \right\rfloor \right) + (192 + LSB) \times 64 \times \left\lfloor \frac{4CNT}{MSB} \right\rfloor \right] \times t_{osc2}$$

Note: In the above formulae, division results must be rounded down to the next integer value.

Example:

With 2 ms timeout selected in MCCSR register

Value of T[5:0] Bits in WDGCR Register (Hex.)	Min. watchdog timeout (ms) t_{min}	Max. watchdog timeout (ms) t_{max}
00	1.496	2.048
3F	128	128.552

Figure 40. Window watchdog timing diagram

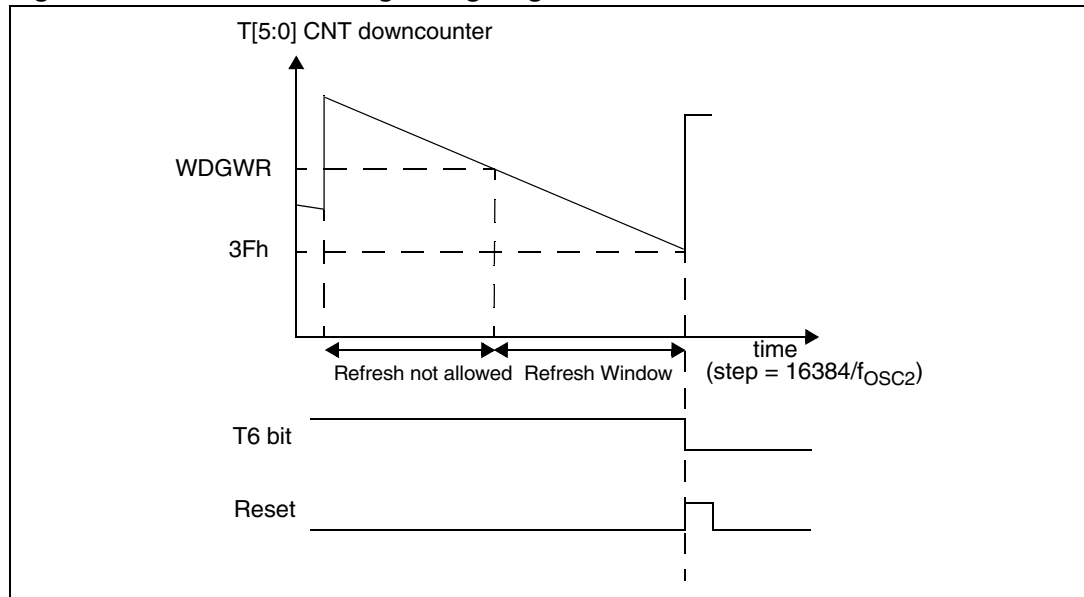

11.1.6 Low-power modes

Table 37. Descriptions

Mode	Description		
Slow	No effect on Watchdog: the downcounter continues to decrement at normal speed.		
Wait	No effect on Watchdog: the downcounter continues to decrement.		
Halt	OIE bit in MCCSR register	WDGHALT bit in Option Byte	
	0	0	No Watchdog reset is generated. The MCU enters Halt mode. The Watchdog counter is decremented once and then stops counting and is no longer able to generate a watchdog reset until the MCU receives an external interrupt or a reset. If an interrupt is received (refer to interrupt table mapping to see interrupts which can occur in halt mode), the Watchdog restarts counting after 256 or 4096 CPU clocks. If a reset is generated, the Watchdog is disabled (reset state) unless Hardware Watchdog is selected by option byte. For application recommendations see Section 11.1.8 below.
	0	1	A reset is generated instead of entering halt mode.
Active-halt	1	x	No reset is generated. The MCU enters Active Halt mode. The Watchdog counter is not decremented. It stop counting. When the MCU receives an oscillator interrupt or external interrupt, the Watchdog restarts counting immediately. When the MCU receives a reset, the Watchdog restarts counting after 256 or 4096 CPU clocks.

11.1.7 Hardware watchdog option

If hardware watchdog is selected by option byte, the watchdog is always active and the WDGA bit in the WDGCR is not used. Refer to the Option Byte description.

11.1.8 Using Halt mode with the WDG (WDGHALT option)

The following recommendation applies if Halt mode is used when the watchdog is enabled.

- Before executing the HALT instruction, refresh the WDG counter, to avoid an unexpected WDG reset immediately after waking up the microcontroller.

11.1.9 Interrupts

None.

11.1.10 Register description

Control register (WDGCR)

Reset value: 0111 1111 (7Fh)

7							0
WDGA	T6	T5	T4	T3	T2	T1	T0
Read/Write							

Bit 7 = **WDGA** Activation bit.

This bit is set by software and only cleared by hardware after a reset. When WDGA = 1, the watchdog can generate a reset.

- 0: Watchdog disabled
- 1: Watchdog enabled

Note: This bit is not used if the hardware watchdog option is enabled by option byte.

Bits 6:0 = **T[6:0]** 7-bit counter (MSB to LSB).

These bits contain the value of the watchdog counter. It is decremented every 16384 f_{OSC2} cycles (approx.). A reset is produced when it rolls over from 40h to 3Fh (T6 becomes cleared).

Window register (WDGWR)

Reset value: 0111 1111 (7Fh)

7							0
-	W6	W5	W4	W3	W2	W1	W0
Read/Write							

Bit 7 = Reserved

Bits 6:0 = **W[6:0]** 7-bit window value

These bits contain the window value to be compared to the downcounter.

Table 38. Watchdog timer register map and reset values

Address (Hex.)	Register label	7	6	5	4	3	2	1	0
2A	WDGCR	WDGA	T6	T5	T4	T3	T2	T1	T0
	Reset value	0	1	1	1	1	1	1	1
30	WDGWR	-	W6	W5	W4	W3	W2	W1	W0
	Reset value	0	1	1	1	1	1	1	1

11.2 Main clock controller with real-time clock and beeper (MCC/RTC)

The main clock controller consists of three different functions:

- a programmable CPU clock prescaler
- a clock-out signal to supply external devices
- a real-time clock timer with interrupt capability

Each function can be used independently and simultaneously.

11.2.1 Programmable CPU clock prescaler

The programmable CPU clock prescaler supplies the clock for the ST7 CPU and its internal peripherals. It manages Slow power-saving mode (See [Section 9.2: Slow mode](#) for more details).

The prescaler selects the f_{CPU} main clock frequency and is controlled by three bits in the MCCR register: CP[1:0] and SMS.

11.2.2 Clock-out capability

The clock-out capability is an alternate function of an I/O port pin that outputs a f_{OSC2} clock to drive external devices. It is controlled by the MCO bit in the MCCR register.

Caution: When selected, the clock out pin suspends the clock during Active-halt mode.

11.2.3 Real-time clock timer (RTC)

The counter of the real-time clock timer allows an interrupt to be generated based on an accurate real-time clock. Four different time bases depending directly on f_{OSC2} are available. The whole functionality is controlled by four bits of the MCCR register: TB[1:0], OIE and OIF.

When the RTC interrupt is enabled (OIE bit set), the ST7 enters Active-halt mode when the HALT instruction is executed. See [Section 9.5: Active-halt mode](#) for more details.

11.2.4 Beeper

The beep function is controlled by the MCCBCR register. It can output three selectable frequencies on the BEEP pin (I/O port alternate function).

Figure 41. Main clock controller (MCC/RTC) block diagram

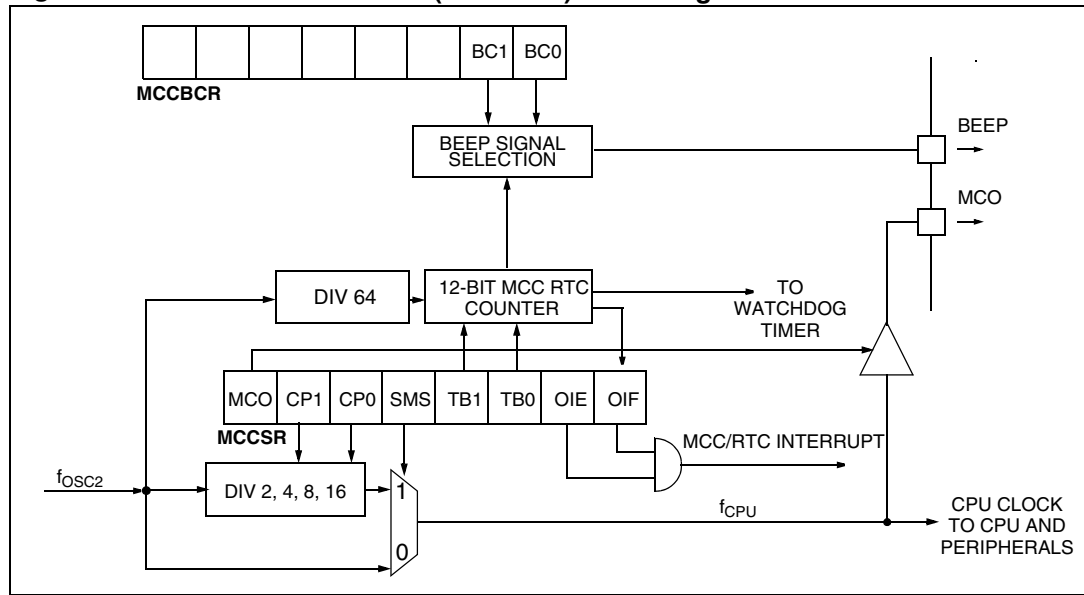

11.2.5 Low-power modes

Table 39. Mode description

Mode	Description
Wait	No effect on MCC/RTC peripheral. MCC/RTC interrupt cause the device to exit from Wait mode.
Active-halt	No effect on MCC/RTC counter (OIE bit is set), the registers are frozen. MCC/RTC interrupt cause the device to exit from Active-halt mode.
Halt	MCC/RTC counter and registers are frozen. MCC/RTC operation resumes when the MCU is woken up by an interrupt with “exit from Halt” capability.

11.2.6 Interrupts

The MCC/RTC interrupt event generates an interrupt if the OIE bit of the MCCSR register is set and the interrupt mask in the CC register is not active (RIM instruction).

Table 40. Interrupt event

Interrupt event	Event flag	Enable Control bit	Exit from Wait	Exit from Halt
Time base overflow event	OIF	OIE	Yes	No ⁽¹⁾

1. The MCC/RTC interrupt wakes up the MCU from Active-halt mode, not from Halt mode.

11.2.7 Register description

MCC control/status register (MCCSR)

Reset value: 0000 0000 (00h)

7							0
MCO	CP1	CP0	SMS	TB1	TB0	OIE	OIF
Read/Write							

Bit 7 = **MCO** Main clock out selection

This bit enables the MCO alternate function on the PF0 I/O port. It is set and cleared by software.

0: MCO alternate function disabled (I/O pin free for general-purpose I/O)

1: MCO alternate function enabled (f_{CPU} on I/O port)

Note: To reduce power consumption, the MCO function is not active in Active-halt mode.

Bits 6:5 = **CP[1:0]** CPU clock prescaler

These bits select the CPU clock prescaler which is applied in the different slow modes.

Their action is conditioned by the setting of the SMS bit. These two bits are set and cleared by software.

Table 41. CPU clock prescaler selection

f_{CPU} in Slow mode	CP1	CP0
$f_{OSC2} / 2$	0	0
$f_{OSC2} / 4$	0	1
$f_{OSC2} / 8$	1	0
$f_{OSC2} / 16$	1	1

Bit 4 = **SMS** Slow mode select

This bit is set and cleared by software.

0: Normal mode. $f_{CPU} = f_{OSC2}$

1: Slow mode. f_{CPU} is given by CP1, CP0

See [Section 9.2: Slow mode](#) and [Section 11.1: Window watchdog \(WWDG\)](#) for more details.

Bits 3:2 = **TB[1:0]** Time base control

These bits select the programmable divider time base. They are set and cleared by software.

Table 42. Time base control

Counter prescaler	Time base		TB1	TB0
	f _{OSC2} = 4 MHz	f _{OSC2} = 8 MHz		
16000	4 ms	2 ms	0	0
32000	8 ms	4 ms	0	1
80000	20 ms	10 ms	1	0
200000	50 ms	25 ms	1	1

A modification of the time base is taken into account at the end of the current period (previously set) to avoid an unwanted time shift. This allows to use this time base as a real-time clock.

Bit 1 = **OIE** *Oscillator interrupt enable*

This bit set and cleared by software.

0: Oscillator interrupt disabled

1: Oscillator interrupt enabled

This interrupt can be used to exit from Active-halt mode.

When this bit is set, calling the ST7 software HALT instruction enters the Active-halt power-saving mode.

Bit 0 = **OIF** *Oscillator interrupt flag*

This bit is set by hardware and cleared by software reading the MCCR register. It indicates when set that the main oscillator has reached the selected elapsed time (TB1:0).

0: Timeout not reached

1: Timeout reached

Caution: The BRES and BSET instructions must not be used on the MCCR register to avoid unintentionally clearing the OIF bit.

MCC beep control register (MCCBCR)

Reset value: 0000 0000 (00h)

7							0
0	0	0	0	0	0	BC1	BC0
Read/Write							

Bits 7:2 = Reserved, must be kept cleared.

Bits 1:0 = **BC[1:0]** *Beep control*

These 2 bits select the PF1 pin beep capability.

Table 43. Beep control

BC1	BC0	Beep mode with $f_{OSC2} = 8\text{ MHz}$	
0	0	Off	
0	1	~2-kHz	Output beep signal ~50% duty cycle
1	0	~1-kHz	
1	1	~500-Hz	

The beep output signal is available in Active-halt mode but has to be disabled to reduce the consumption.

Table 44. Main clock controller register map and reset values

Address (Hex.)	Register label	7	6	5	4	3	2	1	0
002Bh	SICSR Reset value	0	AVDIE 0	AVDF 0	LVDRF x	LOCKED 0	0	0	WDGRF x
002Ch	MCCSR Reset value	MCO 0	CP1 0	CP0 0	SMS 0	TB1 0	TB0 0	OIE 0	OIF 0
002Dh	MCCBCR Reset value	0	0	0	0	0	0	BC1 0	BC0 0

11.3 16-bit timer

11.3.1 Introduction

The timer consists of a 16-bit free-running counter driven by a programmable prescaler.

It may be used for a variety of purposes, including pulse length measurement of up to two input signals (*input capture*) or generation of up to two output waveforms (*output compare* and *PWM*).

Pulse lengths and waveform periods can be modulated from a few microseconds to several milliseconds using the timer prescaler and the CPU clock prescaler.

Some devices of the ST7 family have two on-chip 16-bit timers. They are completely independent, and do not share any resources. They are synchronized after a Device reset as long as the timer clock frequencies are not modified.

This description covers one or two 16-bit timers. In the devices with two timers, register names are prefixed with TA (Timer A) or TB (Timer B).

11.3.2 Main features

- Programmable prescaler: f_{CPU} divided by 2, 4 or 8.
- Overflow status flag and maskable interrupt
- External clock input (must be at least 4 times slower than the CPU clock speed) with the choice of active edge
- Output compare functions with
 - 2 dedicated 16-bit registers
 - 2 dedicated programmable signals
 - 2 dedicated status flags
 - 1 dedicated maskable interrupt
- Input capture functions with
 - 2 dedicated 16-bit registers
 - 2 dedicated active edge selection signals
 - 2 dedicated status flags
 - 1 dedicated maskable interrupt
- Pulse width modulation mode (PWM)
- One-pulse mode
- Reduced-power mode
- 5 alternate functions on I/O ports (ICAP1, ICAP2, OCMP1, OCMP2, EXTCLK). See the note below.

The block diagram is shown in [Figure 42](#).

Note: Some timer pins may not be available (not bonded) in some devices. Refer to the device pin out description. When reading an input signal on a non-bonded pin, the value will always be '1'.

11.3.3 Functional description

Counter

The main block of the programmable timer is a 16-bit free running upcounter and its associated 16-bit registers. The 16-bit registers are made up of two 8-bit registers called high & low.

Counter Register (CR):

- Counter High Register (CHR) is the most significant byte (MS Byte).
- Counter Low Register (CLR) is the least significant byte (LS Byte).

Alternate Counter Register (ACR)

- Alternate Counter High Register (ACHR) is the most significant byte (MS Byte).
- Alternate Counter Low Register (ACLR) is the least significant byte (LS Byte).

These two read-only 16-bit registers contain the same value but with the difference that reading the ACLR register does not clear the TOF bit (Timer overflow flag) located in the Status register (SR). (See the following [Note](#)).

Writing in the CLR register or ACLR register resets the free running counter to the FFFCh value.

Both counters have a reset value of FFFCh (this is the only value which is reloaded in the 16-bit timer). The reset value of both counters is also FFFCh in One-pulse mode and PWM mode.

The timer clock depends on the clock control bits of the CR2 register, as illustrated in [Table 50: Clock control bits](#). The value in the counter register repeats every 131 072, 262 144 or 524 288 CPU clock cycles, depending on the CC[1:0] bits.

The timer frequency can be $f_{CPU}/2$, $f_{CPU}/4$, $f_{CPU}/8$ or an external frequency.

Figure 42. Timer block diagram

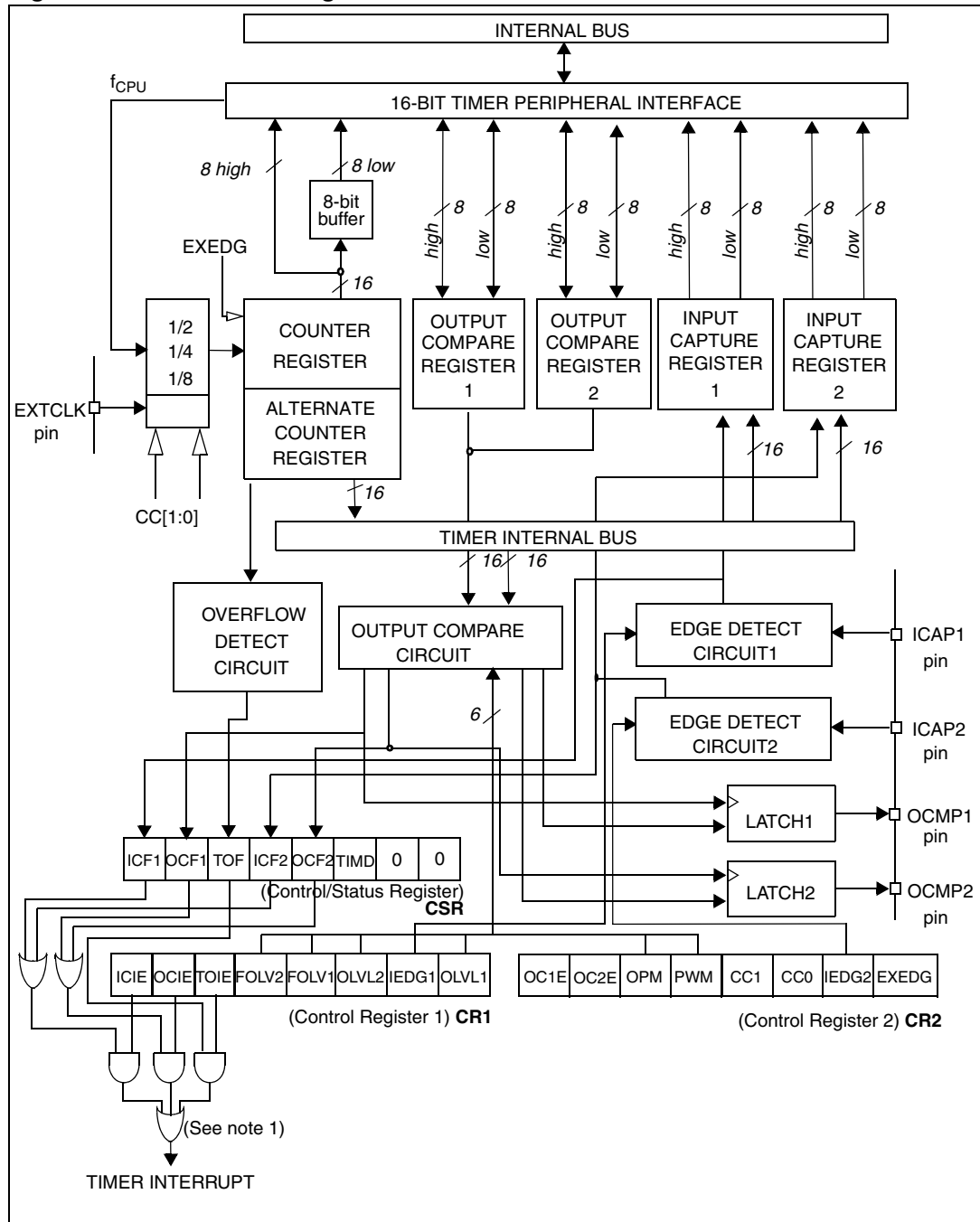

1. If IC, OC and TO interrupt requests have separate vectors, then the last OR is not present (See Device Interrupt Vector Table).

Figure 43. 16-bit read sequence (from either the counter register or the alternate counter register)

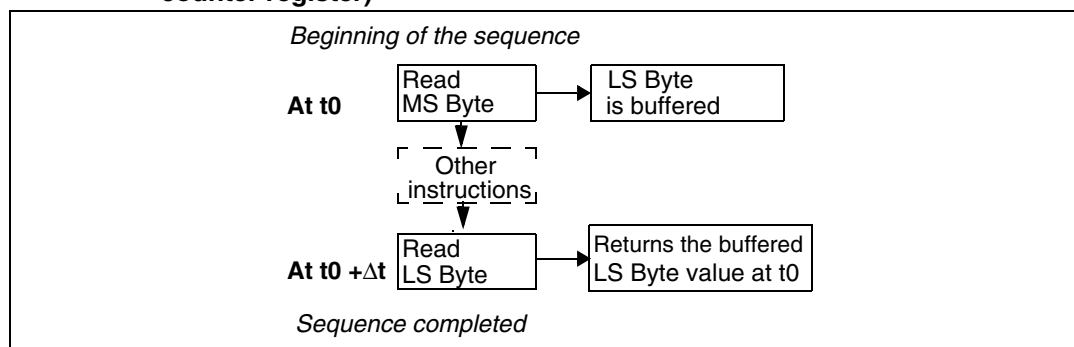

The user must read the MS Byte first, then the LS Byte value is buffered automatically.

This buffered value remains unchanged until the 16-bit read sequence is completed, even if the user reads the MS Byte several times.

After a complete reading sequence, if only the CLR register or ACLR register are read, they return the LS Byte of the count value at the time of the read.

Whatever the timer mode used (input capture, output compare, one-pulse mode or PWM mode) an overflow occurs when the counter rolls over from FFFFh to 0000h then:

- The TOF bit of the SR register is set.
- A timer interrupt is generated if:
 - TOIE bit of the CR1 register is set and
 - I bit of the CC register is cleared.

If one of these conditions is false, the interrupt remains pending to be issued as soon as they are both true.

Clearing the overflow interrupt request is done in two steps:

1. Reading the SR register while the TOF bit is set.
2. An access (read or write) to the CLR register.

Note: The TOF bit is not cleared by accesses to ACLR register. The advantage of accessing the ACLR register rather than the CLR register is that it allows simultaneous use of the overflow function and reading the free running counter at random times (for example, to measure elapsed time) without the risk of clearing the TOF bit erroneously.

The timer is not affected by Wait mode.

In Halt mode, the counter stops counting until the mode is exited. Counting then resumes from the previous count (Device awakened by an interrupt) or from the reset count (Device awakened by a Reset).

External clock

The external clock (where available) is selected if CC0=1 and CC1=1 in CR2 register.

The status of the EXEDG bit in the CR2 register determines the type of level transition on the external clock pin EXTCLK that will trigger the free running counter.

The counter is synchronized with the falling edge of the internal CPU clock.

A minimum of four falling edges of the CPU clock must occur between two consecutive active edges of the external clock; thus, the external clock frequency must be less than a quarter of the CPU clock frequency.

Figure 44. Counter timing diagram, internal clock divided by 2

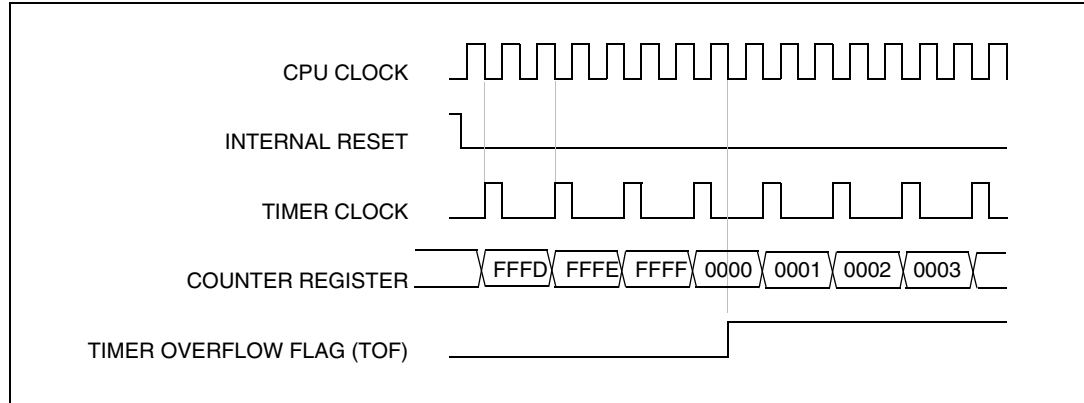

Figure 45. Counter timing diagram, internal clock divided by 4

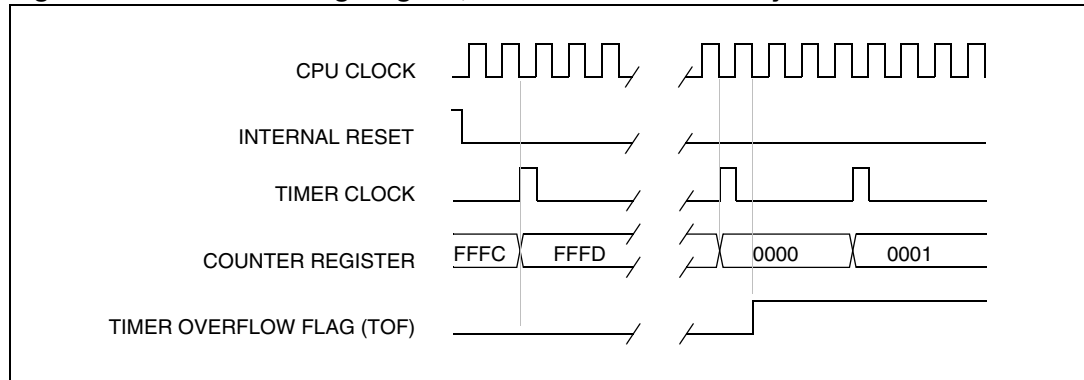
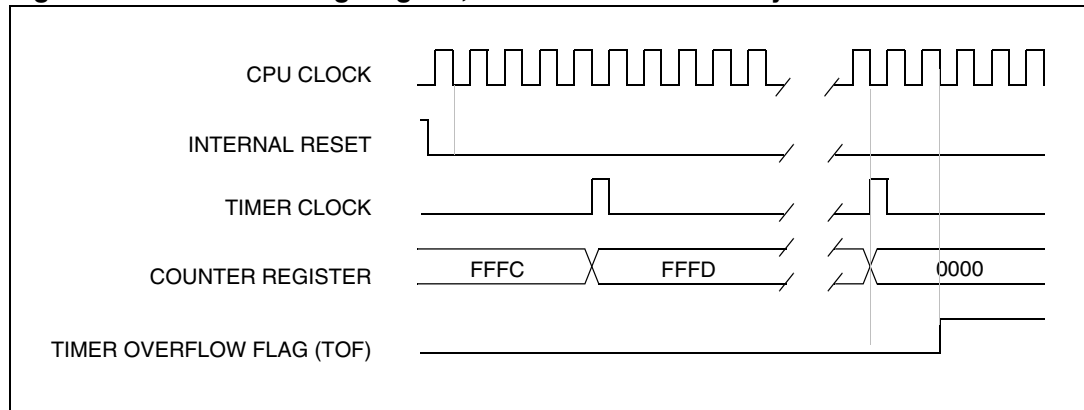

Figure 46. Counter timing diagram, internal clock divided by 8



Note: The device is in reset state when the internal reset signal is high. When it is low, the Device is running.

Input capture

In this section, the index, i , may be 1 or 2 because there are 2 input capture functions in the 16-bit timer.

The two input-capture 16-bit registers (IC1R and IC2R) are used to latch the value of the free-running counter after a transition detected by the ICAP i pin.

Table 45. ICiR register

	MS Byte	LS Byte
ICiR	ICiHR	ICiLR

ICiR register is a read-only register. The active transition is software-programmable through the IEDG i bit of Control Registers (CR i). The timing resolution is one count of the free-running counter: ($f_{CPU}/CC[1:0]$).

Procedure:

To use the input capture function, select the following in the CR2 register:

- Select the timer clock (CC[1:0]) (see [Table 50: Clock control bits](#)).
- Select the edge of the active transition on the ICAP2 pin with the IEDG2 bit (the ICAP2 pin must be configured as floating input).

And select the following in the CR1 register:

- Set the ICIE bit to generate an interrupt after an input capture coming from either the ICAP1 pin or the ICAP2 pin
- Select the edge of the active transition on the ICAP1 pin with the IEDG1 bit (the ICAP1 pin must be configured as floating input).

When an input capture occurs:

- ICF i bit is set.
- The ICiR register contains the value of the free running counter on the active transition on the ICAP i pin (see [Figure 48](#)).
- A timer interrupt is generated if the ICIE bit is set and the I bit is cleared in the CC register. Otherwise, the interrupt remains pending until both conditions become true.

Clearing the Input Capture interrupt request (i.e. clearing the ICF i bit) is done in two steps:

1. Reading the SR register while the ICF i bit is set.
2. An access (read or write) to the ICiLR register.

- Note:**
- 1 After reading the ICiHR register, transfer of input capture data is inhibited and ICF i will never be set until the ICiLR register is also read.
 - 2 The ICiR register contains the free running counter value which corresponds to the most recent input capture.
 - 3 The 2 input capture functions can be used together even if the timer also uses the 2 output compare functions.
 - 4 In One-pulse Mode and PWM mode only the input capture 2 can be used.
 - 5 The alternate inputs (ICAP1 & ICAP2) are always directly connected to the timer. So any transitions on these pins activate the input capture function. Moreover, if one of the ICAP i pins is configured as an input and the second one as an output, an interrupt can be generated provided that the user toggles the output pin and that

the ICIE bit is set. This can be avoided if the input capture function *i* is disabled by reading the ICiHR (see note 1).

- The TOF bit can be used with interrupt in order to measure events that go beyond the timer range (FFFFh).

Figure 47. Input capture block diagram

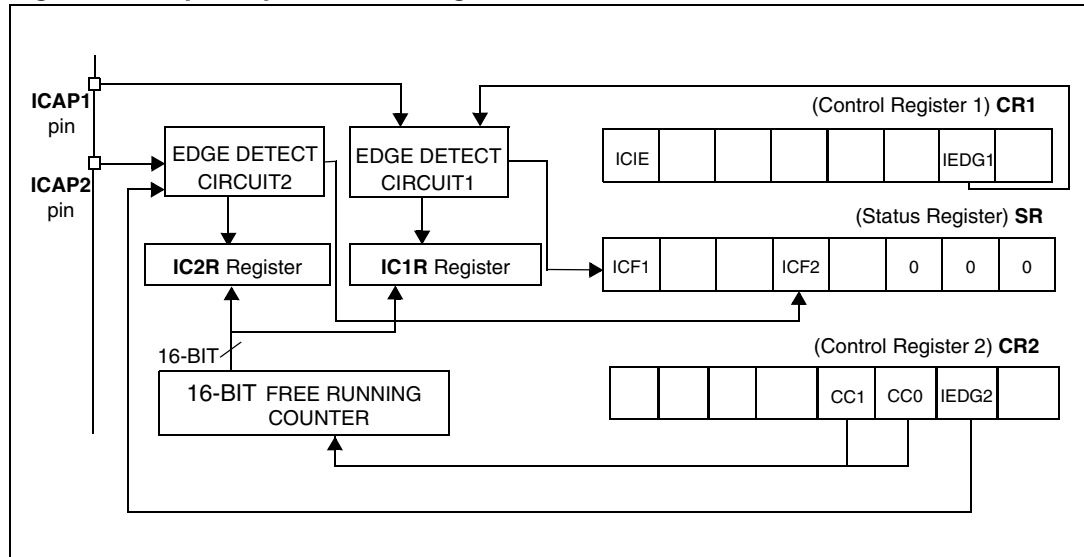
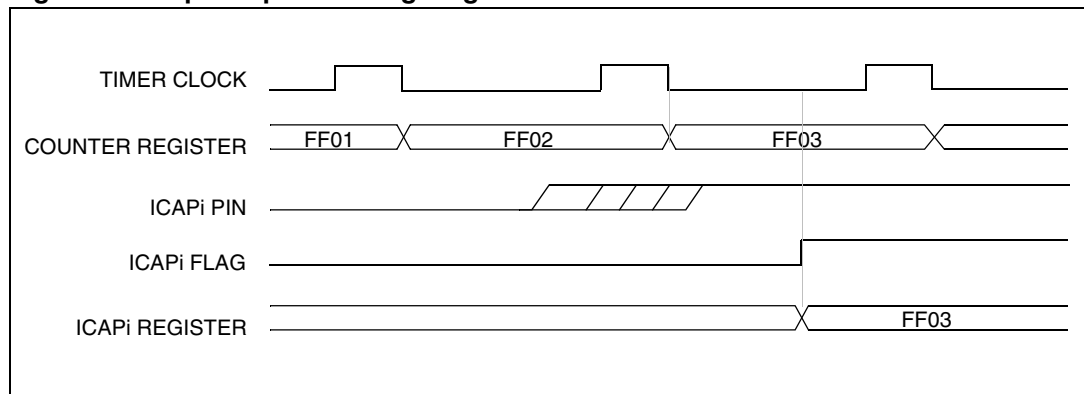

Figure 48. Input capture timing diagram



- The active edge is the rising edge.
- The time between an event on the ICAPi pin and the appearance of the corresponding flag is from 2 to 3 CPU clock cycles. This depends on the moment when the ICAP event happens relative to the timer clock.

Output compare

In this section, the index, *i*, may be 1 or 2 because there are 2 output compare functions in the 16-bit timer.

This function can be used to control an output waveform or indicate when a period of time has elapsed.

When a match is found between the Output Compare register and the free running counter, the output compare function:

- Assigns pins with a programmable value if the OCIE bit is set
- Sets a flag in the status register
- Generates an interrupt if enabled

Two 16-bit registers, Output Compare Register 1 (OC1R) and Output Compare Register 2 (OC2R), contain the value to be compared to the counter register each timer clock cycle.

Table 46. OC/R register

	MS Byte	LS Byte
OC/R	OC/HR	OC/LR

These registers are readable and writable and are not affected by the timer hardware. A reset event changes the OC/R value to 8000h.

The timing resolution is one count of the free running counter: $(f_{\text{CPU}}/CC[1:0])$.

Procedure:

To use the output compare function, select the following in the CR2 register:

- Set the OC/E bit if an output is needed then the OCMP*i* pin is dedicated to the output compare *i* signal.
- Select the timer clock (CC[1:0]) (see [Table 50: Clock control bits](#)).

And select the following in the CR1 register:

- Select the OLVL*i* bit to applied to the OCMP*i* pins after the match occurs.
- Set the OCIE bit to generate an interrupt if it is needed.

When a match is found between OCR*i* register and CR register:

- OCF*i* bit is set.
- The OCMP*i* pin takes OLVL*i* bit value (OCMP*i* pin latch is forced low during reset).
- A timer interrupt is generated if the OCIE bit is set in the CR2 register and the I bit is cleared in the CC register (CC).

The OC/R register value required for a specific timing application can be calculated using the following formula:

$$\Delta \text{OC/R} = \frac{\Delta t * f_{\text{CPU}}}{\text{PRESC}}$$

Where:

- Δt = Output compare period (in seconds)
- f_{CPU} = CPU clock frequency (in Hertz)
- PRESC = Timer prescaler factor (2, 4 or 8 depending on CC[1:0] bits, see [Table 50](#))

If the timer clock is an external clock, the formula is:

$$\Delta \text{OC/R} = \Delta t * f_{\text{EXT}}$$

Where:

- Δt = Output compare period (in seconds)
- f_{EXT} = External timer clock frequency (in Hertz)

Clearing the output compare interrupt request (i.e. clearing the OCF_i bit) is done by:

1. Reading the SR register while the OCF_i bit is set.
2. An access (read or write) to the OC_iLR register.

The following procedure is recommended to prevent the OCF_i bit from being set between the time it is read and the write to the OC_iR register:

- Write to the OC_iHR register (further compares are inhibited).
- Read the SR register (first step of the clearance of the OCF_i bit, which may be already set).
- Write to the OC_iLR register (enables the output compare function and clears the OCF_i bit).

- Note:**
- 1 After a processor write cycle to the OC_iHR register, the output compare function is inhibited until the OC_iLR register is also written.
 - 2 If the OC_iE bit is not set, the OCMP_i pin is a general I/O port and the OLV_i bit will not appear when a match is found but an interrupt could be generated if the OC_iE bit is set.
 - 3 In both internal and external clock modes, OCF_i and OCMP_i are set while the counter value equals the OC_iR register value (see Figure 50 and Figure 51). This behavior is the same in OPM or PWM mode.
 - 4 The output compare functions can be used both for generating external events on the OCMP_i pins even if the input capture mode is also used.
 - 5 The value in the 16-bit OC_iR register and the OLV_i bit should be changed after each successful comparison in order to control an output waveform or establish a new elapsed timeout.

Forced compare output capability

When the FOLV_i bit is set by software, the OLV_i bit is copied to the OCMP_i pin. The OLV_i bit has to be toggled in order to toggle the OCMP_i pin when it is enabled (OC_iE bit=1). The OCF_i bit is then not set by hardware, and thus no interrupt request is generated.

FOLV_i bits have no effect in both one-pulse mode and PWM mode.

Figure 49. Output compare block diagram

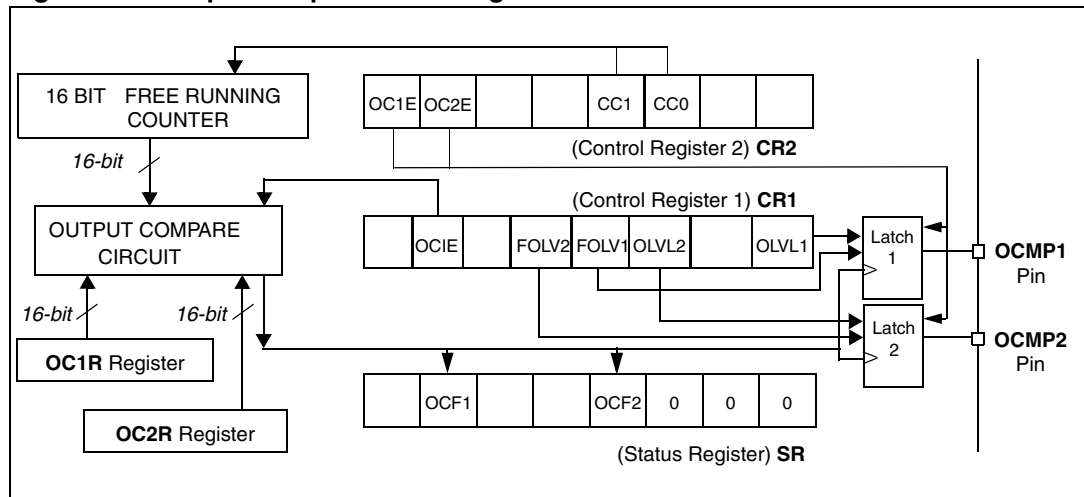

Figure 50. Output compare timing diagram, $f_{\text{TIMER}} = f_{\text{CPU}}/2$

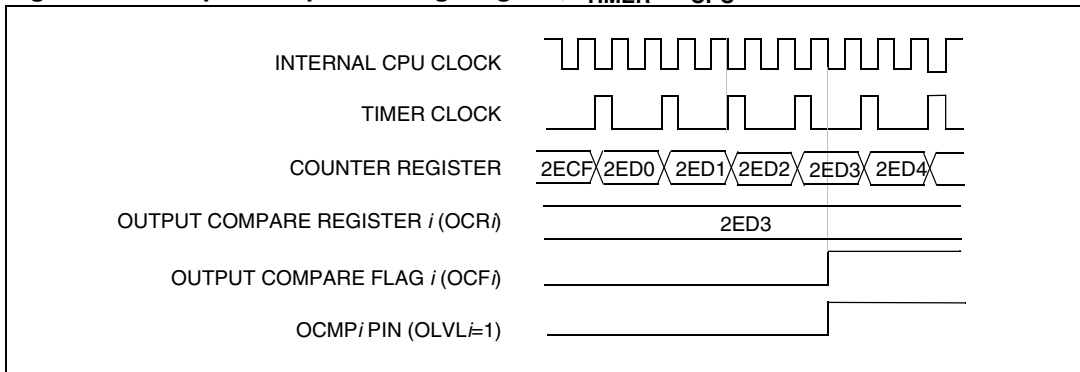
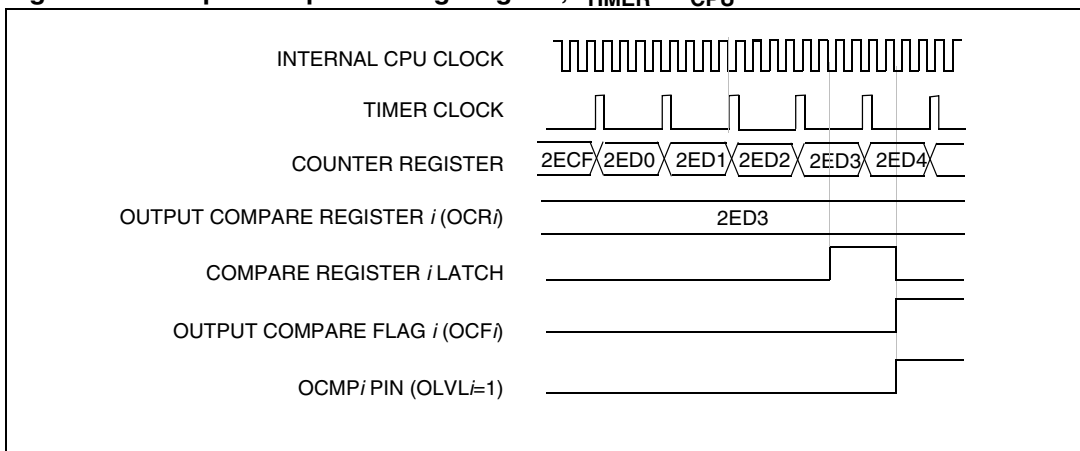

Figure 51. Output compare timing diagram, $f_{\text{TIMER}} = f_{\text{CPU}}/4$



One-pulse mode

One-pulse mode enables the generation of a pulse when an external event occurs. This mode is selected via the OPM bit in the CR2 register.

The one-pulse mode uses the Input Capture1 function and the Output Compare1 function.

Procedure:

To use one-pulse mode:

1. Load the OC1R register with the value corresponding to the length of the pulse (see the formula in the opposite column).
2. Select the following in the CR1 register:
 - Using the OLVL1 bit, select the level to be applied to the OCMP1 pin after the pulse.
 - Using the OLVL2 bit, select the level to be applied to the OCMP1 pin during the pulse.
 - Select the edge of the active transition on the ICAP1 pin with the IEDG1 bit (the ICAP1 pin must be configured as floating input).
3. Select the following in the CR2 register:
 - Set the OC1E bit, the OCMP1 pin is then dedicated to the Output Compare 1 function.
 - Set the OPM bit.
 - Select the timer clock CC[1:0] (see [Table 50: Clock control bits](#)).

Figure 52. One-pulse mode cycle

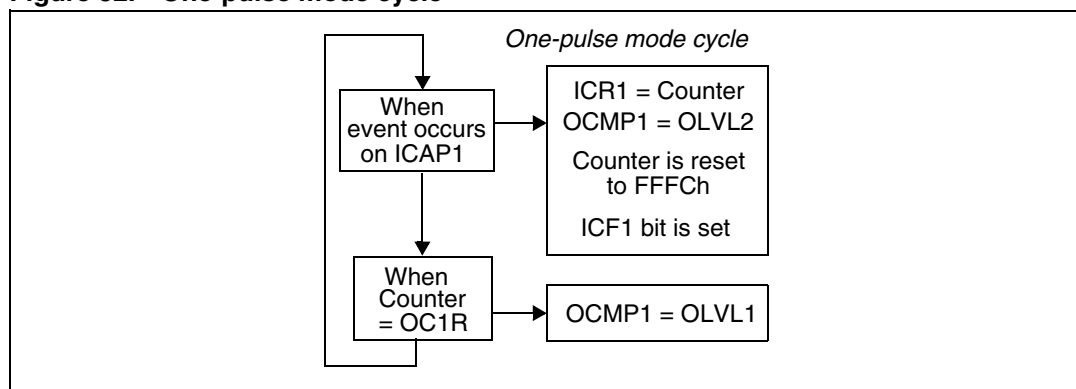

When a valid event occurs on the ICAP1 pin, the counter value is loaded in the ICR1 register. The counter is then initialized to FFFCh, the OLVL2 bit is output on the OCMP1 pin and the ICF1 bit is set.

Because the ICF1 bit is set when an active edge occurs, an interrupt can be generated if the ICIE bit is set.

Clearing the Input Capture interrupt request (i.e. clearing the ICF*i* bit) is done in two steps:

1. Reading the SR register while the ICF*i* bit is set.
2. An access (read or write) to the IC*i*LR register.

The OC1R register value required for a specific timing application can be calculated using the following formula:

$$OC1R \text{ Value} = \frac{t \cdot f_{CPU}}{PRESC} - 5$$

Where:

- t = Pulse period (in seconds)
- f_{CPU} = CPU clock frequency (in Hertz)
- PRESC = Timer prescaler factor (2, 4 or 8 depending on the CC[1:0] bits, see [Table 50: Clock control bits](#))

If the timer clock is an external clock the formula is:

$$OC1R = t \cdot f_{EXT} - 5$$

Where:

- t = Pulse period (in seconds)
- f_{EXT} = External timer clock frequency (in Hertz)

When the value of the counter is equal to the value of the contents of the OC1R register, the OLVL1 bit is output on the OCMP1 pin (See [Figure 53](#)).

- Note:*
- 1 The OCF1 bit cannot be set by hardware in One-pulse mode but the OCF2 bit can generate an Output Compare interrupt.
 - 2 When the Pulse Width Modulation (PWM) and One-pulse mode (OPM) bits are both set, the PWM mode is the only active one.
 - 3 If OLVL1=OLVL2 a continuous signal will be seen on the OCMP1 pin.
 - 4 The ICAP1 pin can not be used to perform input capture. The ICAP2 pin can be used to perform input capture (ICF2 can be set and IC2R can be loaded) but the user must take care that the counter is reset each time a valid edge occurs on the ICAP1 pin and ICF1 can also generate interrupt if ICIE is set.
 - 5 When One-pulse mode is used, OC1R is dedicated to this mode. Nevertheless, OC2R and OCF2 can be used to indicate that a period of time has been elapsed but cannot generate an output waveform, because the OLVL2 level is dedicated to the One-pulse mode.

Figure 53. One-pulse mode timing example

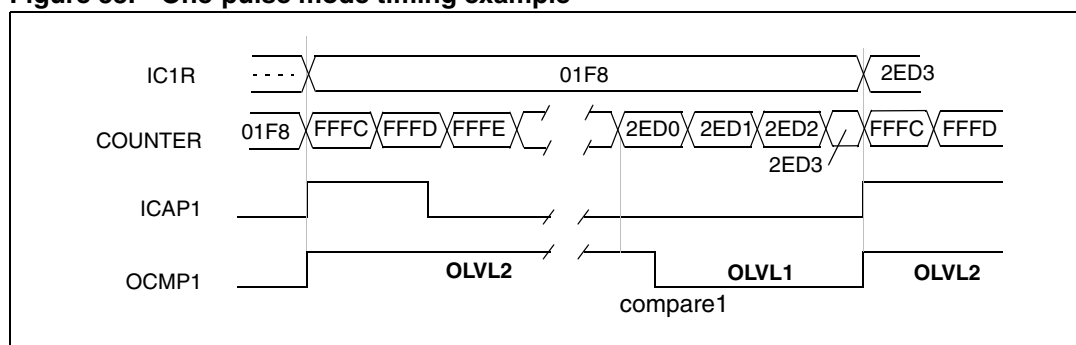

1. IEDG1=1, OC1R=2ED0h, OLVL1=0, OLVL2=1.

Figure 54. Pulse width modulation mode timing example

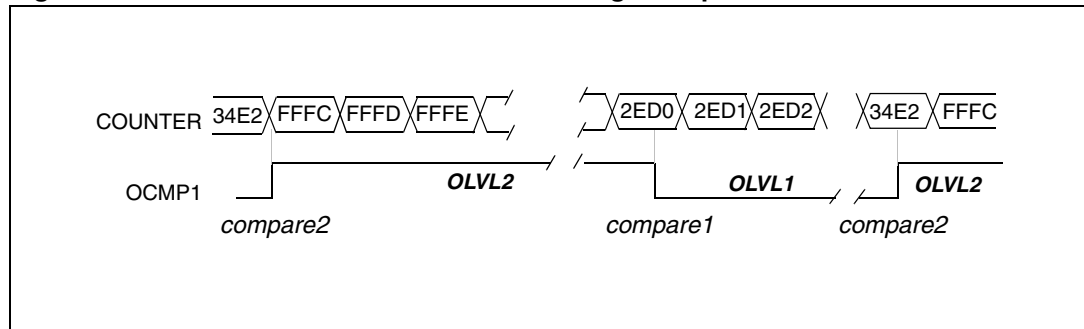

1. OC1R = 2ED0h, OC2R = 34E2, OLVL1 = 0, OLVL2 = 1

Pulse-width modulation mode

Pulse-width modulation (PWM) mode enables the generation of a signal with a frequency and pulse length determined by the value of the OC1R and OC2R registers.

Pulse-width modulation mode uses the complete Output Compare 1 function plus the OC2R register, and so this functionality can not be used when PWM mode is activated.

In PWM mode, double buffering is implemented on the output compare registers. Any new values written in the OC1R and OC2R registers are loaded in their respective shadow registers (double buffer) only at the end of the PWM period (OC2) to avoid spikes on the PWM output pin (OCMP1). The shadow registers contain the reference values for comparison in PWM “double buffering” mode.

Note: There is a locking mechanism for transferring the OCiR value to the buffer. After a write to the OCiHR register, the transfer of the new compare value to the buffer is inhibited until OCiLR is also written.

Unlike in Output Compare mode, the compare function is always enabled in PWM mode.

Procedure:

To use pulse-width modulation mode:

1. Load the OC2R register with the value corresponding to the period of the signal using the formula in the opposite column.
2. Load the OC1R register with the value corresponding to the period of the pulse if (OLVL1=0 and OLVL2=1) using the formula in the opposite column.
3. Select the following in the CR1 register:
 - Using the OLVL1 bit, select the level to be applied to the OCMP1 pin after a successful comparison with OC1R register.
 - Using the OLVL2 bit, select the level to be applied to the OCMP1 pin after a successful comparison with OC2R register.
4. Select the following in the CR2 register:
 - Set OC1E bit: the OCMP1 pin is then dedicated to the output compare 1 function.
 - Set the PWM bit.
 - Select the timer clock (CC[1:0]) (see [Table 50: Clock control bits](#)).

Figure 55. Pulse width modulation cycle

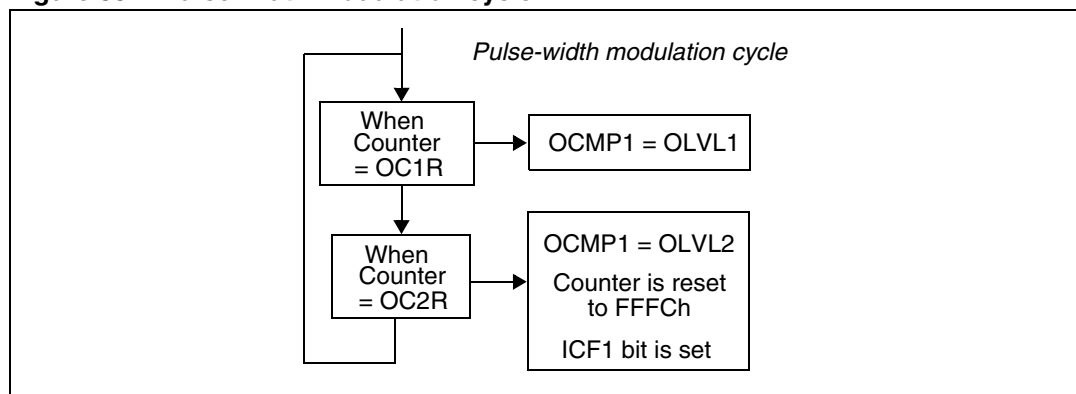

If OLVL1=1 and OLVL2=0 the length of the positive pulse is the difference between the OC2R and OC1R registers.

If OLVL1=OLVL2 a continuous signal will be seen on the OCMP1 pin.

The OC/R register value required for a specific timing application can be calculated using the following formula:

$$OC/R \text{ Value} = \frac{t \cdot f_{CPU}}{PRESC} - 5$$

Where:

- t = Signal or pulse period (in seconds)
- f_{CPU} = CPU clock frequency (in Hertz)
- PRESC = Timer prescaler factor (2, 4 or 8 depending on CC[1:0] bits, see [Table 50: Clock control bits](#))

If the timer clock is an external clock the formula is:

$$OC/R = t \cdot f_{EXT} - 5$$

Where:

- t = Signal or pulse period (in seconds)
- f_{EXT} = External timer clock frequency (in Hertz)

The Output Compare 2 event causes the counter to be initialized to FFFCh (See [Figure 54](#))

- Note:**
- 1 The OCF1 and OCF2 bits cannot be set by hardware in PWM mode; therefore, the Output Compare interrupt is inhibited.
 - 2 The ICF1 bit is set by hardware when the counter reaches the OC2R value; it can produce a timer interrupt if the ICIE bit is set and the I bit is cleared.
 - 3 In PWM mode, the ICAP1 pin cannot be used to perform an input capture because it is disconnected to the timer. The ICAP2 pin can be used to perform an input capture (ICF2 can be set and IC2R can be loaded) but the user must take care that the counter is reset each period, and ICF1 can also generate an interrupt if ICIE is set.
 - 4 When the pulse-width modulation (PWM) and One-pulse mode (OPM) bits are both set, the PWM mode is the only active one.

11.3.4 Low-power modes

Table 47. Low-power mode description

Mode	Description
Wait	No effect on 16-bit timer. Timer interrupts cause the Device to exit from Wait mode.
Halt	16-bit timer registers are frozen. In Halt mode, the counter stops counting until Halt mode is exited. Counting resumes from the previous count when the Device is woken up by an interrupt with “exit from Halt mode” capability or from the counter reset value when the Device is woken up by a reset. If an input capture event occurs on the ICAP <i>i</i> pin, the input capture detection circuitry is armed. Consequently, when the Device is woken up by an interrupt with “exit from Halt mode” capability, the ICF <i>i</i> bit is set, and the counter value present when exiting from Halt mode is captured into the IC/R register.

11.3.5 Interrupts

Table 48. Interrupt events

Interrupt event	Event flag	Enable control bit	Exit from Wait	Exit from Halt
Input Capture 1 event/Counter reset in PWM mode	ICF1	ICIE	Yes	No
Input Capture 2 event	ICF2		Yes	No
Output Compare 1 event (not available in PWM mode)	OCF1	OCIE	Yes	No
Output Compare 2 event (not available in PWM mode)	OCF2		Yes	No
Timer overflow event	TOF	TOIE	Yes	No

Note: The 16-bit timer interrupt events are connected to the same interrupt vector (see [Section 8: Interrupts](#)). These events generate an interrupt if the corresponding Enable Control Bit is set and the interrupt mask in the CC register is reset (RIM instruction).

11.3.6 Summary of timer modes

Table 49. Timer modes

Modes	Available resources			
	Input Capture 1	Input Capture 2	Output Compare 1	Output Compare 2
Input Capture (1 and/or 2)	Yes	Yes	Yes	Yes
Output Compare (1 and/or 2)	Yes	Yes	Yes	Yes
One-pulse mode	No	Not recommended ⁽¹⁾	No	Partially ⁽²⁾
PWM mode	No	Not recommended ⁽³⁾	No	No

1. See note 4 in [One-pulse mode](#).

2. See note 5 in [One-pulse mode](#).

3. See note 4 in [Pulse-width modulation mode](#).

11.3.7 Register description

Each timer is associated with three control and status registers, and with six pairs of data registers (16-bit values) related to the two input captures, the two output compares, the counter and the alternate counter.

Control register 1 (CR1)

Read/Write

Reset value: 0000 0000 (00h)

7							0
ICIE	OCIE	TOIE	FOLV2	FOLV1	OLVL2	IEDG1	OLVL1
Read/Write							

Bit 7 = **ICIE** *Input Capture Interrupt Enable*.

0: Interrupt is inhibited.

1: A timer interrupt is generated whenever the ICF1 or ICF2 bit of the SR register is set.

Bit 6 = **OCIE** *Output Compare Interrupt Enable*.

0: Interrupt is inhibited.

1: A timer interrupt is generated whenever the OCF1 or OCF2 bit of the SR register is set.

Bit 5 = **TOIE** *Timer Overflow Interrupt Enable*.

0: Interrupt is inhibited.

1: A timer interrupt is enabled whenever the TOF bit of the SR register is set.

Bit 4 = **FOLV2** *Forced Output Compare 2*.

This bit is set and cleared by software.

0: No effect on the OCMP2 pin.

1: Forces the OLVL2 bit to be copied to the OCMP2 pin, if the OC2E bit is set and even if there is no successful comparison.

Bit 3 = **FOLV1** *Forced Output Compare 1.*

This bit is set and cleared by software.

0: No effect on the OCMP1 pin.

1: Forces OLV1 to be copied to the OCMP1 pin, if the OC1E bit is set and even if there is no successful comparison.

Bit 2 = **OLVL2** *Output Level 2.*

This bit is copied to the OCMP2 pin whenever a successful comparison occurs with the OC2R register and OCxE is set in the CR2 register. This value is copied to the OCMP1 pin in One-pulse mode and Pulse-width modulation mode.

Bit 1 = **IEDG1** *Input Edge 1.*

This bit determines which type of level transition on the ICAP1 pin will trigger the capture.

0: A falling edge triggers the capture.

1: A rising edge triggers the capture.

Bit 0 = **OLVL1** *Output Level 1.*

The OLVL1 bit is copied to the OCMP1 pin whenever a successful comparison occurs with the OC1R register and the OC1E bit is set in the CR2 register.

Control register 2 (CR2)

Reset value: 0000 0000 (00h)

7	0						
OC1E	OC2E	OPM	PWM	CC1	CC0	IEDG2	EXEDG
Read/Write							

Bit 7 = **OC1E** *Output Compare 1 Pin Enable.*

This bit is used only to output the signal from the timer on the OCMP1 pin (OLV1 in Output Compare mode, both OLV1 and OLV2 in PWM and one-pulse mode). Whatever the value of the OC1E bit, the Output Compare 1 function of the timer remains active.

0: OCMP1 pin alternate function disabled (I/O pin free for general-purpose I/O).

1: OCMP1 pin alternate function enabled.

Bit 6 = **OC2E** *Output Compare 2 Pin Enable.*

This bit is used only to output the signal from the timer on the OCMP2 pin (OLV2 in Output Compare mode). Whatever the value of the OC2E bit, the Output Compare 2 function of the timer remains active.

0: OCMP2 pin alternate function disabled (I/O pin free for general-purpose I/O).

1: OCMP2 pin alternate function enabled.

Bit 5 = **OPM** *One-pulse Mode.*

0: One-pulse Mode is not active.

1: One-pulse Mode is active, the ICAP1 pin can be used to trigger one pulse on the OCMP1 pin; the active transition is given by the IEDG1 bit. The length of the generated pulse depends on the contents of the OC1R register.

Bit 4 = **PWM** *Pulse-Width Modulation.*

0: PWM mode is not active.

1: PWM mode is active, the OCMP1 pin outputs a programmable cyclic signal; the

length of the pulse depends on the value of OC1R register; the period depends on the value of OC2R register.

Bits 3:2 = **CC[1:0]** *Clock Control*.

The timer clock mode depends on these bits:

Table 50. Clock control bits

Timer clock	CC1	CC0
$f_{CPU} / 4$	0	0
$f_{CPU} / 2$	0	1
$f_{CPU} / 8$	1	0
External clock (where available)	1	1

Note: If the external clock pin is not available, programming the external clock configuration stops the counter.

Bit 1 = **IEDG2** *Input Edge 2*.

This bit determines which type of level transition on the ICAP2 pin will trigger the capture.

- 0: A falling edge triggers the capture.
- 1: A rising edge triggers the capture.

Bit 0 = **EXEDG** *External Clock Edge*.

This bit determines which type of level transition on the external clock pin EXTCLK will trigger the counter register.

- 0: A falling edge triggers the counter register.
- 1: A rising edge triggers the counter register.

Control/status register (CSR)

Reset value: 0000 0000 (00h)

The three least significant bits are not used.

7							0
ICF1	OCF1	TOF	ICF2	OCF2	TIMD	0	0
Read-only							

Bit 7 = **ICF1** *Input Capture Flag 1*.

- 0: No input capture (reset value).
- 1: An input capture has occurred on the ICAP1 pin or the counter has reached the OC2R value in PWM mode. To clear this bit, first read the SR register, then read or write the low byte of the IC1R (IC1LR) register.

Bit 6 = **OCF1** *Output Compare Flag 1*.

- 0: No match (reset value).
- 1: The content of the free running counter has matched the content of the OC1R register. To clear this bit, first read the SR register, then read or write the low byte of the OC1R (OC1LR) register.

Bit 5 = **TOF** *Timer Overflow Flag*.

0: No timer overflow (reset value).

1: The free running counter rolled over from FFFFh to 0000h. To clear this bit, first read the SR register, then read or write the low byte of the CR (CLR) register.

Note: Reading or writing the ACLR register does not clear TOF.

Bit 4 = **ICF2** *Input Capture Flag 2*.

0: No input capture (reset value).

1: An input capture has occurred on the ICAP2 pin. To clear this bit, first read the SR register, then read or write the low byte of the IC2R (IC2LR) register.

Bit 3 = **OCF2** *Output Compare Flag 2*.

0: No match (reset value).

1: The content of the free running counter has matched the content of the OC2R register. To clear this bit, first read the SR register, then read or write the low byte of the OC2R (OC2LR) register.

Bit 2 = **TIMD** *Timer disable*.

This bit is set and cleared by software. When set, it freezes the timer prescaler and counter and disabled the output functions (OCMP1 and OCMP2 pins) to reduce power consumption. Access to the timer registers is still available, allowing the timer configuration to be changed while it is disabled.

0: Timer enabled

1: Timer prescaler, counter and outputs disabled

Bits 1:0 = Reserved, must be kept cleared.

Input capture 1 high register (IC1HR)

Reset value: Undefined

This is an 8-bit read-only register that contains the high part of the counter value (transferred by the input capture 1 event).

7							0
MSB							LSB
Read Only							

Input capture 1 low register (IC1LR)

Reset value: Undefined

This is an 8-bit read only register that contains the low part of the counter value (transferred by the input capture 1 event).

7							0
MSB							LSB
Read Only							

Output compare 1 high register (OC1HR)

Read/Write

Reset value: 1000 0000 (80h)

This is an 8-bit register that contains the high part of the value to be compared to the CHR register.

7							0
MSB							LSB
Read/Write							

Output compare 1 low register (OC1LR)

Reset value: 0000 0000 (00h)

This is an 8-bit register that contains the low part of the value to be compared to the CLR register.

7							0
MSB							LSB
Read/Write							

Output compare 2 high register (OC2HR)

Reset value: 1000 0000 (80h)

This is an 8-bit register that contains the high part of the value to be compared to the CHR register.

7							0
MSB							LSB
Read/Write							

Output compare 2 low register (OC2LR)

Reset value: 0000 0000 (00h)

This is an 8-bit register that contains the low part of the value to be compared to the CLR register.

7							0
MSB							LSB
Read/Write							

Counter high register (CHR)

Reset value: 1111 1111 (FFh)

This is an 8-bit register that contains the high part of the counter value.

7							0
MSB							LSB
Read-only							

Counter low register (CLR)

Reset value: 1111 1100 (FCh)

This is an 8-bit register that contains the low part of the counter value. A write to this register resets the counter. An access to this register, after accessing the CSR register, clears the TOF bit.

7							0
MSB							LSB
Read-only							

Alternate counter high register (ACHR)

Reset value: 1111 1111 (FFh)

This is an 8-bit register that contains the high part of the counter value.

7							0
MSB							LSB
Read-only							

Alternate counter low register (ACLR)

Reset value: 1111 1100 (FCh)

This is an 8-bit register that contains the low part of the counter value. A write to this register resets the counter. An access to this register after an access to CSR register does not clear the TOF bit in the CSR register.

7							0
MSB							LSB
Read-only							

Input capture 2 high register (IC2HR)

Reset value: Undefined

This is an 8-bit read only register that contains the high part of the counter value (transferred by the Input Capture 2 event).

7							0
MSB							LSB
Read-only							

Input capture 2 low register (IC2LR)

Reset value: Undefined

This is an 8-bit read only register that contains the low part of the counter value (transferred by the Input Capture 2 event).

7							0
MSB							LSB
Read-only							

Table 51. 16-bit timer register map and reset values

Address (Hex.)	Register label	7	6	5	4	3	2	1	0
Timer A: 32 Timer B: 42	CR1 Reset value	ICIE 0	OCIE 0	TOIE 0	FOLV2 0	FOLV1 0	OLVL2 0	IEDG1 0	OLVL1 0
Timer A: 31 Timer B: 41	CR2 Reset value	OC1E 0	OC2E 0	OPM 0	PWM 0	CC1 0	CC0 0	IEDG2 0	EXEDG 0
Timer A: 33 Timer B: 43	CSR Reset value	ICF1 x	OCF1 x	TOF x	ICF2 x	OCF2 x	TIMD 0	- x	- x
Timer A: 34 Timer B: 44	IC1HR Reset value	MSB x	x	x	x	x	x	x	LSB x
Timer A: 35 Timer B: 45	IC1LR Reset value	MSB x	x	x	x	x	x	x	LSB x
Timer A: 36 Timer B: 46	OC1HR Reset value	MSB 1	0	0	0	0	0	0	LSB 0
Timer A: 37 Timer B: 47	OC1LR Reset value	MSB 0	0	0	0	0	0	0	LSB 0
Timer A: 3E Timer B: 4E	OC2HR Reset value	MSB 1	0	0	0	0	0	0	LSB 0
Timer A: 3F Timer B: 4F	OC2LR Reset value	MSB 0	0	0	0	0	0	0	LSB 0
Timer A: 38 Timer B: 48	CHR Reset value	MSB 1	1	1	1	1	1	1	LSB 1
Timer A: 39 Timer B: 49	CLR Reset value	MSB 1	1	1	1	1	1	0	LSB 0
Timer A: 3A Timer B: 4A	ACHR Reset value	MSB 1	1	1	1	1	1	1	LSB 1
Timer A: 3B Timer B: 4B	ACLR Reset value	MSB 1	1	1	1	1	1	0	LSB 0
Timer A: 3C Timer B: 4C	IC2HR Reset value	MSB x	x	x	x	x	x	x	LSB x
Timer A: 3D Timer B: 4D	IC2LR Reset value	MSB x	x	x	x	x	x	x	LSB x

11.4 Serial peripheral interface (SPI)

11.4.1 Introduction

The serial peripheral interface (SPI) allows full-duplex, synchronous, serial communication with external devices. An SPI system may consist of a master and one or more slaves, or a system in which devices may be either masters or slaves.

11.4.2 Main features

- Full-duplex synchronous transfers (on three lines)
- Simplex synchronous transfers (on two lines)
- Master or slave operation
- 6 master mode frequencies ($f_{CPU}/4$ max.)
- $f_{CPU}/2$ max. slave mode frequency (see the note)
- \overline{SS} Management by software or hardware
- Programmable clock polarity and phase
- End-of-transfer interrupt flag
- Write collision, master mode fault and Overrun flags

Note: In slave mode, continuous transmission is not possible at maximum frequency due to the software overhead for clearing status flags and to initiate the next transmission sequence.

11.4.3 General description

[Figure 56 on page 116](#) shows the serial peripheral interface (SPI) block diagram. There are three registers:

- SPI Control Register (SPICR)
- SPI Control/Status Register (SPICSR)
- SPI Data Register (SPIDR)

The SPI is connected to external devices through four pins:

- MISO: Master In / Slave Out data
- MOSI: Master Out / Slave In data
- SCK: Serial Clock out by SPI masters and input by SPI slaves
- \overline{SS} : Slave select:

This input signal acts as a 'chip select' to let the SPI master communicate with slaves individually and to avoid contention on the data lines. Slave \overline{SS} inputs can be driven by standard I/O ports on the master Device.

Figure 56. Serial peripheral interface block diagram

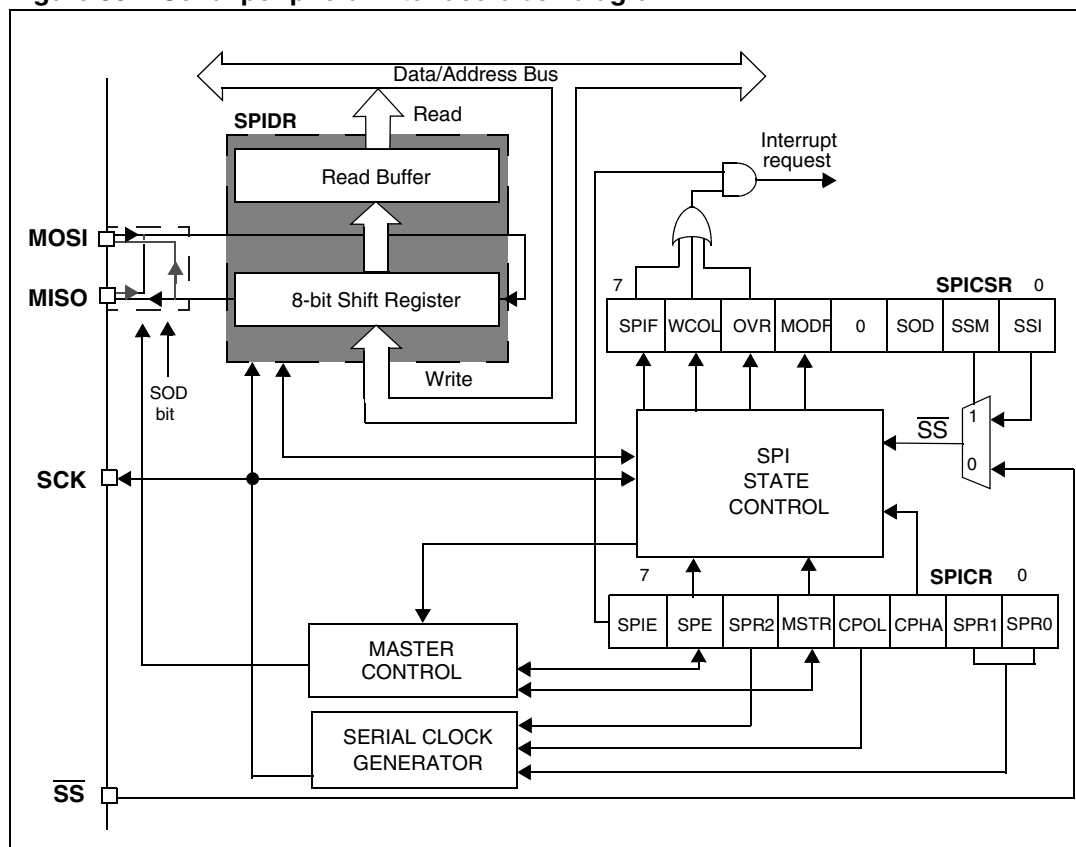

Functional description

A basic example of interconnections between a single master and a single slave is illustrated in [Figure 57](#).

The MOSI pins are connected together and the MISO pins are connected together. In this way data is transferred serially between master and slave (most significant bit first).

The communication is always initiated by the master. When the master device transmits data to a slave device via MOSI pin, the slave device responds by sending data to the master device via the MISO pin. This implies full duplex communication with both data out and data in, synchronized with the same clock signal (which is provided by the master device via the SCK pin).

To use a single data line, the MISO and MOSI pins must be connected at each node (in this case only simplex communication is possible).

Four possible data/clock timing relationships may be chosen (see [Figure 60](#)) but master and slave must be programmed with the same timing mode.

Figure 57. Single master/ single slave application

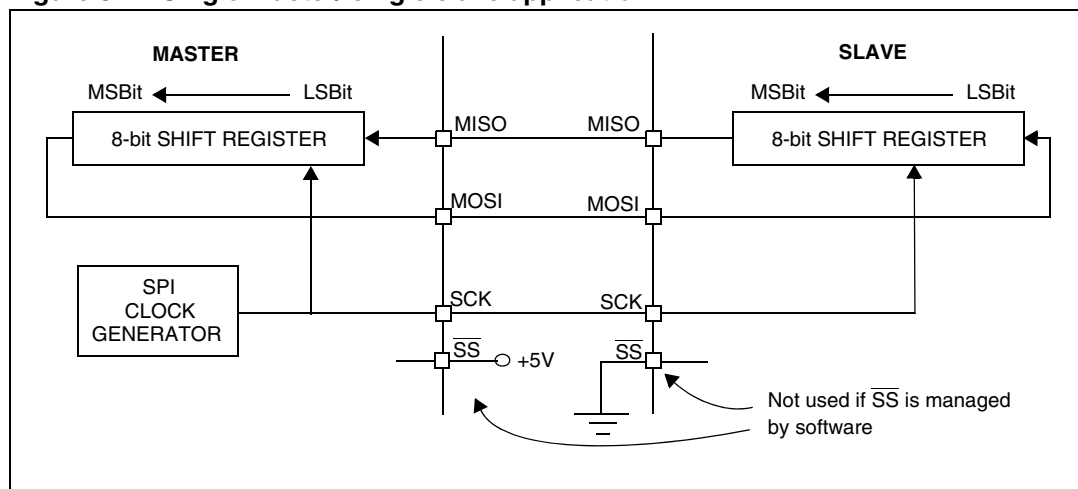

Slave select management

As an alternative to using the \overline{SS} pin to control the Slave Select signal, the application can choose to manage the Slave Select signal by software. This is configured by the SSM bit in the SPICSR register (see [Figure 59](#)).

In software management, the external \overline{SS} pin is free for other application uses and the internal \overline{SS} signal level is driven by writing to the SSI bit in the SPICSR register.

- In Master mode:
 - \overline{SS} internal must be held high continuously
- In Slave Mode:

There are two cases depending on the data/clock timing relationship (see [Figure 58](#)):

If CPHA = 1 (data latched on second clock edge):

 - \overline{SS} internal must be held low during the entire transmission. This implies that in single slave applications the \overline{SS} pin either can be tied to V_{SS} , or made free for standard I/O by managing the \overline{SS} function by software (SSM = 1 and SSI = 0 in the in the SPICSR register)

If CPHA = 0 (data latched on first clock edge):

 - \overline{SS} internal must be held low during byte transmission and pulled high between each byte to allow the slave to write to the shift register. If \overline{SS} is not pulled high, a Write Collision error will occur when the slave writes to the shift register (see [Write collision error \(WCOL\)](#)).

Figure 58. Generic \overline{SS} timing diagram

Figure 59. Hardware/software slave select management



Master mode operation

In master mode, the serial clock is output on the SCK pin. The clock frequency, polarity and phase are configured by software (refer to the description of the SPICSR register).

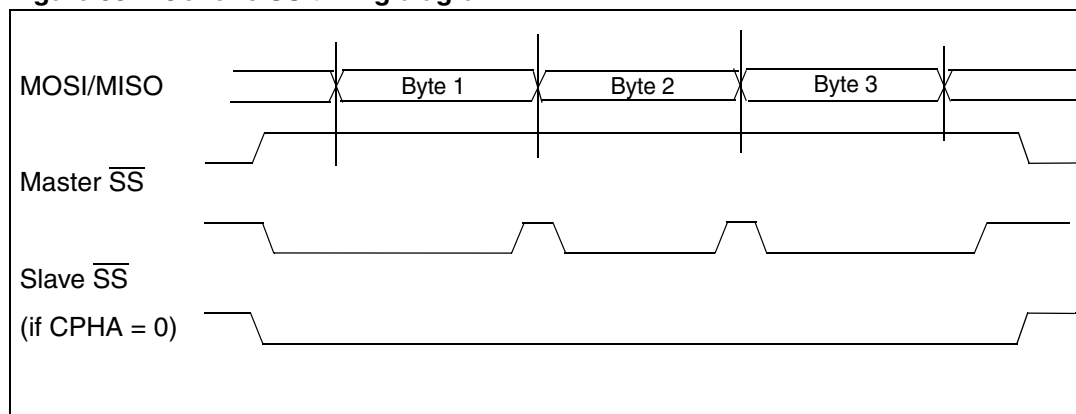
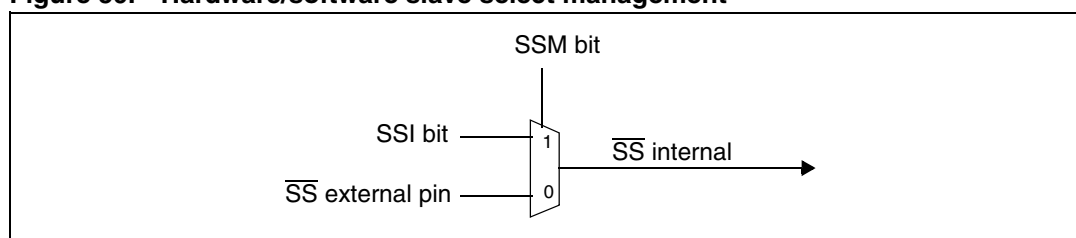
Note: The idle state of SCK must correspond to the polarity selected in the SPICSR register (by pulling up SCK if CPOL = 1 or pulling down SCK if CPOL = 0).

How to operate the SPI in master mode

To operate the SPI in master mode, perform the following steps in order:

1. Write to the SPICR register:
 - Select the clock frequency by configuring the SPR[2:0] bits.
 - Select the clock polarity and clock phase by configuring the CPOL and CPHA bits. [Figure 60](#) shows the four possible configurations. Note that the slave must have the same CPOL and CPHA settings as the master.
2. Write to the SPICSR register:
 - Either set the SSM bit and set the SSI bit or clear the SSM bit and tie the \overline{SS} pin high for the complete byte transmit sequence.
3. Write to the SPICR register:
 - Set the MSTR and SPE bits. Note that the MSTR and SPE bits remain set only if \overline{SS} is high).

Note: **Important:** if the SPICSR register is not written first, the SPICR register setting (MSTR bit) may be not taken into account.

The transmit sequence begins when the software writes a byte in the SPIDR register.

Master mode transmit sequence

When software writes to the SPIDR register, the data byte is loaded into the 8-bit shift register and then shifted out serially to the MOSI pin most significant bit first.

When data transfer is complete:

- The SPIF bit is set by hardware.
- An interrupt request is generated if the SPIE bit is set and the interrupt mask in the CCR register is cleared.

Clearing the SPIF bit is performed by the following software sequence:

1. An access to the SPICSR register while the SPIF bit is set
2. A read to the SPIDR register

Note: While the SPIF bit is set, all writes to the SPIDR register are inhibited until the SPICSR register is read.

Slave mode operation

In slave mode, the serial clock is received on the SCK pin from the master device.

To operate the SPI in slave mode:

1. Write to the SPICSR register to perform the following actions:
 - Select the clock polarity and clock phase by configuring the CPOL and CPHA bits (see [Figure 60](#)).
Note that the slave must have the same CPOL and CPHA settings as the master.
 - Manage the \overline{SS} pin as described in [Slave select management](#) and [Figure 58](#).
If CPHA = 1, \overline{SS} must be held low continuously.
If CPHA = 0, \overline{SS} must be held low during byte transmission and pulled up between each byte to let the slave write in the shift register.
2. Write to the SPICR register to clear the MSTR bit and set the SPE bit to enable the SPI I/O functions.

Slave mode transmit sequence

When the software writes to the SPIDR register, the data byte is loaded into the 8-bit shift register and then shifted out serially to the MISO pin most significant bit first.

The transmit sequence begins when the slave device receives the clock signal and the most significant bit of the data on its MOSI pin.

When data transfer is complete:

- The SPIF bit is set by hardware.
- An interrupt request is generated if SPIE bit is set and interrupt mask in the CCR register is cleared.

Clearing the SPIF bit is performed by the following software sequence:

1. An access to the SPICSR register while the SPIF bit is set
2. A write or a read to the SPIDR register

Note: While the SPIF bit is set, all writes to the SPIDR register are inhibited until the SPICSR register is read.

The SPIF bit can be cleared during a second transmission; however, it must be cleared before the second SPIF bit in order to prevent an Overrun condition (see [Overrun condition \(OVR\)](#)).

11.4.4 Clock phase and clock polarity

Four possible timing relationships may be chosen by software, using the CPOL and CPHA bits (See [Figure 60](#)).

Note: The idle state of SCK must correspond to the polarity selected in the SPICSR register (by pulling up SCK if CPOL = 1 or pulling down SCK if CPOL = 0).

The combination of the CPOL clock polarity and CPHA (clock phase) bits selects the data capture clock edge.

[Figure 60](#) shows an SPI transfer with the four combinations of the CPHA and CPOL bits. The diagram may be interpreted as a master or slave timing diagram where the SCK pin, the MISO pin and the MOSI pin are directly connected between the master and the slave device.

Note: If CPOL is changed at the communication byte boundaries, the SPI must be disabled by resetting the SPE bit.

Figure 60. Data clock timing diagram

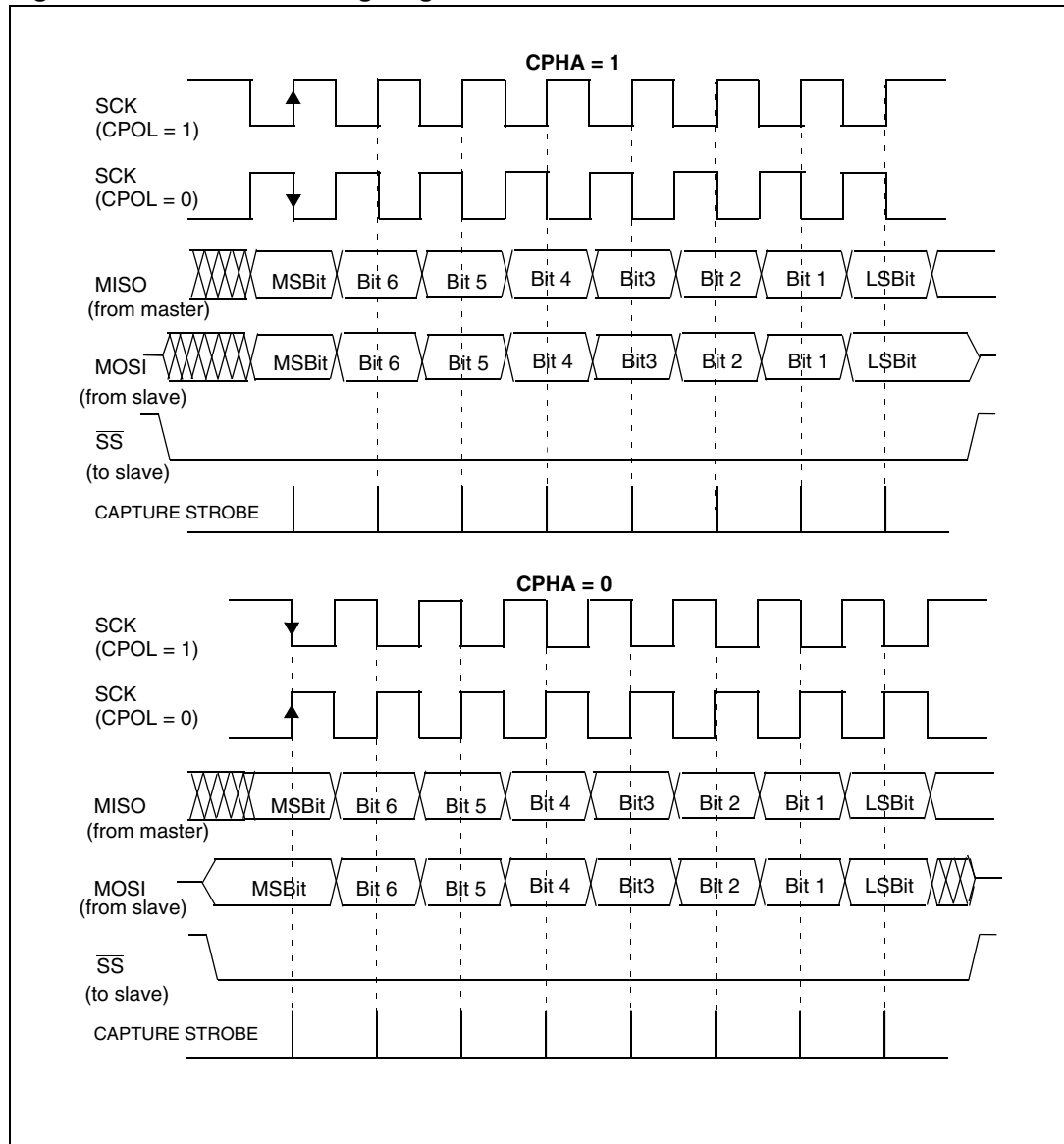

1. This figure should not be used as a replacement for parametric information. Refer to [Section 13: Electrical characteristics](#).

11.4.5 Error flags

Master mode fault (MODF)

Master mode fault occurs when the master device's \overline{SS} pin is pulled low.

When a Master mode fault occurs:

- The MODF bit is set and an SPI interrupt request is generated if the SPIE bit is set.
- The SPE bit is reset. This blocks all output from the device and disables the SPI peripheral.
- The MSTR bit is reset, thus forcing the device into slave mode.

Clearing the MODF bit is done through a software sequence:

1. A read access to the SPICSR register while the MODF bit is set.
2. A write access to the SPICR register.

Note: To avoid any conflicts in an application with multiple slaves, the \overline{SS} pin must be pulled high during the MODF bit clearing sequence. The SPE and MSTR bits may be restored to their original state during or after this clearing sequence.

The hardware does not allow the user to set the SPE and MSTR bits while the MODF bit is set, except in the MODF bit clearing sequence.

In a slave device, the MODF bit can not be set, but in a multimaster configuration the device can be in slave mode with the MODF bit set.

The MODF bit indicates that there might have been a multimaster conflict and allows software to handle this using an interrupt routine and either perform a reset or return to an application default state.

Overrun condition (OVR)

An overrun condition occurs when the master device has sent a data byte and the slave device has not cleared the SPIF bit issued from the previously transmitted byte.

When an Overrun occurs:

- The OVR bit is set, and an interrupt request is generated if the SPIE bit is set.

In this case, the receiver buffer contains the byte sent after the SPIF bit was last cleared. A read to the SPIDR register returns this byte. All other bytes are lost.

The OVR bit is cleared by reading the SPICSR register.

Write collision error (WCOL)

A write collision occurs when the software tries to write to the SPIDR register while a data transfer is taking place with an external device. When this happens, the transfer continues uninterrupted and the software write will be unsuccessful.

Write collisions can occur both in master and slave mode. See also [Slave select management](#).

Note: A “read collision” will never occur since the received data byte is placed in a buffer in which access is always synchronous with the CPU operation.

The WCOL bit in the SPICSR register is set if a write collision occurs.

No SPI interrupt is generated when the WCOL bit is set (the WCOL bit is a status flag only).

Clearing the WCOL bit is done through a software sequence (see [Figure 61](#)).

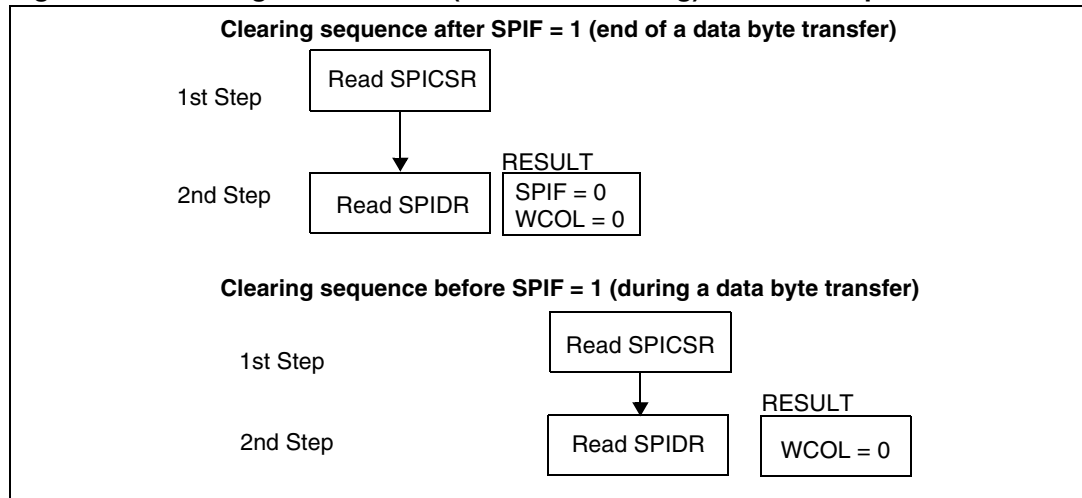
Figure 61. Clearing the WCOL bit (write collision flag) software sequence

1. Writing to the SPIDR register instead of reading it does not reset the WCOL bit.

Single master and multimaster configurations

There are two types of SPI systems: Single master system and Multimaster system.

- **Single master system**

A typical single master system may be configured using a device as the master and four devices as slaves (see [Figure 62](#)).

The master device selects the individual slave devices by using four pins of a parallel port to control the four \overline{SS} pins of the slave devices.

The \overline{SS} pins are pulled high during reset since the master device ports will be forced to be inputs at that time, thus disabling the slave devices.

Note: To prevent a bus conflict on the MISO line, the master allows only one active slave device during a transmission.

For more security, the slave device may respond to the master with the received data byte. Then the master will receive the previous byte back from the slave device if all MISO and MOSI pins are connected and the slave has not written to its SPIDR register. Other transmission security methods can use ports for handshake lines or data bytes with command fields.

- **Multimaster system**

A multimaster system may also be configured by the user. Transfer of master control could be implemented using a handshake method through the I/O ports or by an exchange of code messages through the serial peripheral interface system.

The multimaster system is principally handled by the MSTR bit in the SPICR register, and the MODF bit in the SPICSR register.

Figure 62. Single master / multiple slave configuration

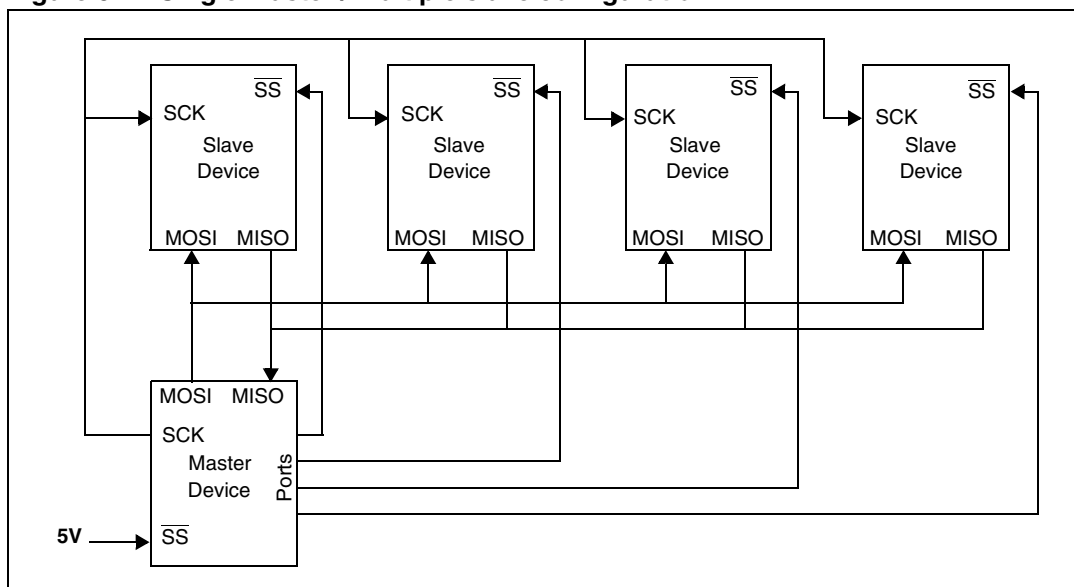

11.4.6 Low-power modes

Table 52. Description

Mode	Description
Wait	No effect on SPI. SPI interrupt events cause the device to exit from Wait mode.
Halt	SPI registers are frozen. In Halt mode, the SPI is inactive. SPI operation resumes when the device is woken up by an interrupt with “exit from Halt mode” capability. The data received is subsequently read from the SPIDR register when the software is running (interrupt vector fetching). If several data are received before the wake-up event, then an overrun error is generated. This error can be detected after the fetch of the interrupt routine that woke up the Device.

Using the SPI to wake up the device from Halt mode

In slave configuration, the SPI is able to wake up the device from Halt mode through a SPIF interrupt. The data received is subsequently read from the SPIDR register when the software is running (interrupt vector fetch). If multiple data transfers have been performed before software clears the SPIF bit, then the OVR bit is set by hardware.

Note: When waking up from Halt mode, if the SPI remains in Slave mode, it is recommended to perform an extra communications cycle to bring the SPI from Halt mode state to normal state. If the SPI exits from Slave mode, it returns to normal state immediately.

Caution: The SPI can wake up the device from Halt mode only if the Slave Select signal (external \overline{SS} pin or the SSI bit in the SPICSR register) is low when the device enters Halt mode. So, if Slave selection is configured as external (see [Slave select management](#)), make sure the master drives a low level on the \overline{SS} pin when the slave enters Halt mode.

11.4.7 Interrupts

Table 53. Interrupt events

Interrupt event	Event flag	Enable control bit	Exit from Wait	Exit from Halt
SPI end of transfer event	SPIF	SPIE	Yes	Yes
Master mode fault event	MODF			No
Overrun error	OVR			

Note: The SPI interrupt events are connected to the same interrupt vector (see [Section 8: Interrupts](#)). They generate an interrupt if the corresponding Enable Control Bit is set and the interrupt mask in the CC register is reset (RIM instruction).

11.4.8 Register description

SPI control register (SPICR)

Reset value: 0000 xxxx (0xh)

7							0
SPIE	SPE	SPR2	MSTR	CPOL	CPHA	SPR1	SPR0
Read/Write							

Bit 7 = **SPIE** Serial Peripheral Interrupt Enable

This bit is set and cleared by software.

0: Interrupt is inhibited

1: An SPI interrupt is generated whenever an End of Transfer event, Master Mode Fault or Overrun error occurs (SPIF = 1, MODF = 1 or OVR = 1 in the SPICSR register)

Bit 6 = **SPE** Serial Peripheral Output Enable

This bit is set and cleared by software. It is also cleared by hardware when, in master mode, $\overline{SS} = 0$ (see [Master mode fault \(MODF\)](#)). The SPE bit is cleared by reset, so the SPI peripheral is not initially connected to the external pins.

0: I/O pins free for general purpose I/O

1: SPI I/O pin alternate functions enabled

Bit 5 = **SPR2** Divider Enable

This bit is set and cleared by software and is cleared by reset. It is used with the SPR[1:0] bits to set the baud rate. Refer to [Table 54: SPI master mode SCK frequency](#).

0: Divider by 2 enabled

1: Divider by 2 disabled

Note: This bit has no effect in slave mode.

Bit 4 = **MSTR** Master Mode

This bit is set and cleared by software. It is also cleared by hardware when, in master mode, $\overline{SS} = 0$ (see *Master mode fault (MODF)*).

0: Slave mode

1: Master mode. The function of the SCK pin changes from an input to an output and the functions of the MISO and MOSI pins are reversed.

Bit 3 = **CPOL** Clock Polarity

This bit is set and cleared by software. This bit determines the idle state of the serial Clock. The CPOL bit affects both the master and slave modes.

0: SCK pin has a low level idle state

1: SCK pin has a high level idle state

Note: If CPOL is changed at the communication byte boundaries, the SPI must be disabled by resetting the SPE bit.

Bit 2 = **CPHA** Clock Phase

This bit is set and cleared by software.

0: The first clock transition is the first data capture edge.

1: The second clock transition is the first capture edge.

Note: The slave must have the same CPOL and CPHA settings as the master.

Bits 1:0 = **SPR[1:0]** Serial clock frequency

These bits are set and cleared by software. Used with the SPR2 bit, they select the baud rate of the SPI serial clock SCK output by the SPI in master mode.

Note: These 2 bits have no effect in slave mode.

Table 54. SPI master mode SCK frequency

Serial clock	SPR2	SPR1	SPR0
$f_{CPU}/4$	1	0	0
$f_{CPU}/8$	0		1
$f_{CPU}/16$		1	1
$f_{CPU}/32$	0	0	
$f_{CPU}/64$		1	
$f_{CPU}/128$			1

SPI control/status register (SPICSR)

Reset value: 0000 0000 (00h)

7							0
SPIF	WCOL	OVR	MODF	-	SOD	SSM	SSI
Read-only				Reserved	Read/Write		

Bit 7 = SPIF *Serial Peripheral Data Transfer Flag (Read-only)*

This bit is set by hardware when a transfer has been completed. An interrupt is generated if SPIE = 1 in the SPICR register. It is cleared by a software sequence (an access to the SPICSR register followed by a write or a read to the SPIDR register).

0: Data transfer is in progress or the flag has been cleared.

1: Data transfer between the device and an external device has been completed.

Note: While the SPIF bit is set, all writes to the SPIDR register are inhibited until the SPICSR register is read.

Bit 6 = WCOL *Write collision status (Read-only)*

This bit is set by hardware when a write to the SPIDR register is done during a transmit sequence. It is cleared by a software sequence (see [Figure 61](#)).

0: No write collision occurred

1: A write collision has been detected

Bit 5 = OVR *SPI overrun error (Read-only)*

This bit is set by hardware when the byte currently being received in the shift register is ready to be transferred into the SPIDR register while SPIF = 1 (See [Overrun condition \(OVR\)](#)). An interrupt is generated if SPIE = 1 in the SPICR register. The OVR bit is cleared by software reading the SPICSR register.

0: No overrun error

1: Overrun error detected

Bit 4 = MODF *Mode fault flag (Read-only)*

This bit is set by hardware when the \overline{SS} pin is pulled low in master mode (see [Master mode fault \(MODF\)](#)). An SPI interrupt can be generated if SPIE = 1 in the SPICR register. This bit is cleared by a software sequence (An access to the SPICSR register while MODF = 1 followed by a write to the SPICR register).

0: No master mode fault detected

1: A fault in master mode has been detected

Bit 3 = Reserved, must be kept cleared.

Bit 2 = SOD *SPI Output disable*

This bit is set and cleared by software. When set, it disables the alternate function of the SPI output (MOSI in master mode / MISO in slave mode)

0: SPI output enabled (if SPE = 1)

1: SPI output disabled

Bit 1 = SSM \overline{SS} *management*

This bit is set and cleared by software. When set, it disables the alternate function of the SPI \overline{SS} pin and uses the SSI bit value instead. See [Slave select management](#).

0: Hardware management (\overline{SS} managed by external pin)

1: Software management (internal SS signal controlled by SSI bit. External \overline{SS} pin free for general-purpose I/O)

Bit 0 = SSI \overline{SS} *internal mode*

This bit is set and cleared by software. It acts as a 'chip select' by controlling the level of the \overline{SS} slave select signal when the SSM bit is set.

0: Slave selected

1: Slave deselected

SPI data I/O register (SPIDR)

Reset value: Undefined

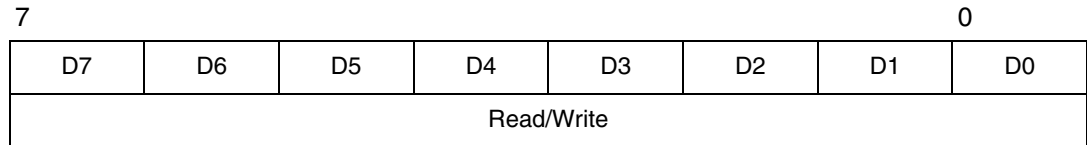

The SPIDR register is used to transmit and receive data on the serial bus. In a master device, a write to this register will initiate transmission/reception of another byte.

Note: During the last clock cycle the SPIF bit is set, a copy of the received data byte in the shift register is moved to a buffer. When the user reads the serial peripheral data I/O register, the buffer is actually being read.

While the SPIF bit is set, all writes to the SPIDR register are inhibited until the SPICSR register is read.

Warning: A write to the SPIDR register places data directly into the shift register for transmission.

A read to the SPIDR register returns the value located in the buffer and not the content of the shift register (see [Figure 56](#)).

Table 55. SPI register map and reset values

Address (Hex.)	Register label	7	6	5	4	3	2	1	0
0021h	SPIDR Reset value	MSB x	x	x	x	x	x	x	LSB x
0022h	SPICR Reset value	SPIE 0	SPE 0	SPR2 0	MSTR 0	CPOL x	CPHA x	SPR1 x	SPR0 x
0023h	SPICSR Reset value	SPIF 0	WCOL 0	OR 0	MODF 0		SOD 0	SSM 0	SSI 0

11.5 SCI serial communication interface

11.5.1 Introduction

The serial communications interface (SCI) offers a flexible means of full-duplex data exchange with external equipment requiring an industry standard NRZ asynchronous serial data format. The SCI offers a very wide range of baud rates using two baud rate generator systems.

11.5.2 Main features

- Full-duplex, asynchronous communications
- NRZ standard format (Mark/Space)
- Dual baud rate generator systems
- Independently programmable transmit and receive baud rates up to 500,000 baud
- Programmable data word length (8 or 9 bits)
- Receive buffer full, Transmit buffer empty and End of Transmission flags
- 2 receiver wake-up modes:
 - Address bit (MSB)
 - Idle line
- Muting function for multiprocessor configurations
- Separate enable bits for Transmitter and Receiver
- 4 error detection flags:
 - Overrun error
 - Noise error
 - Frame error
 - Parity error
- 5 interrupt sources with flags:
 - Transmit data register empty
 - Transmission complete
 - Receive data register full
 - Idle line received
 - Overrun error detected
- Parity control:
 - Transmits parity bit
 - Checks parity of received data byte
- Reduced power consumption mode

11.5.3 General description

The interface is externally connected to another device by three pins (see [Figure 63](#)). Any SCI bidirectional communication requires a minimum of two pins: Receive Data In (RDI) and Transmit Data Out (TDO):

- SCLK: Transmitter clock output. This pin outputs the transmitter data clock for synchronous transmission (no clock pulses on start bit and stop bit, and a software option to send a clock pulse on the last data bit). This can be used to control

peripherals that have shift registers (e.g. LCD drivers). The clock phase and polarity are software programmable.

- TDO: Transmit Data Output. When the transmitter is disabled, the output pin returns to its I/O port configuration. When the transmitter is enabled and nothing is to be transmitted, the TDO pin is at high level.
- RDI: Receive Data Input is the serial data input. Oversampling techniques are used for data recovery by discriminating between valid incoming data and noise.

Through these pins, serial data is transmitted and received as frames comprising:

- An Idle Line prior to transmission or reception
- A start bit
- A data word (8 or 9 bits) least significant bit first
- A Stop bit indicating that the frame is complete.

This interface uses two types of baud rate generator:

- A conventional type for commonly-used baud rates,
- An extended type with a prescaler offering a very wide range of baud rates, even with non-standard oscillator frequencies.

Figure 63. SCI block diagram

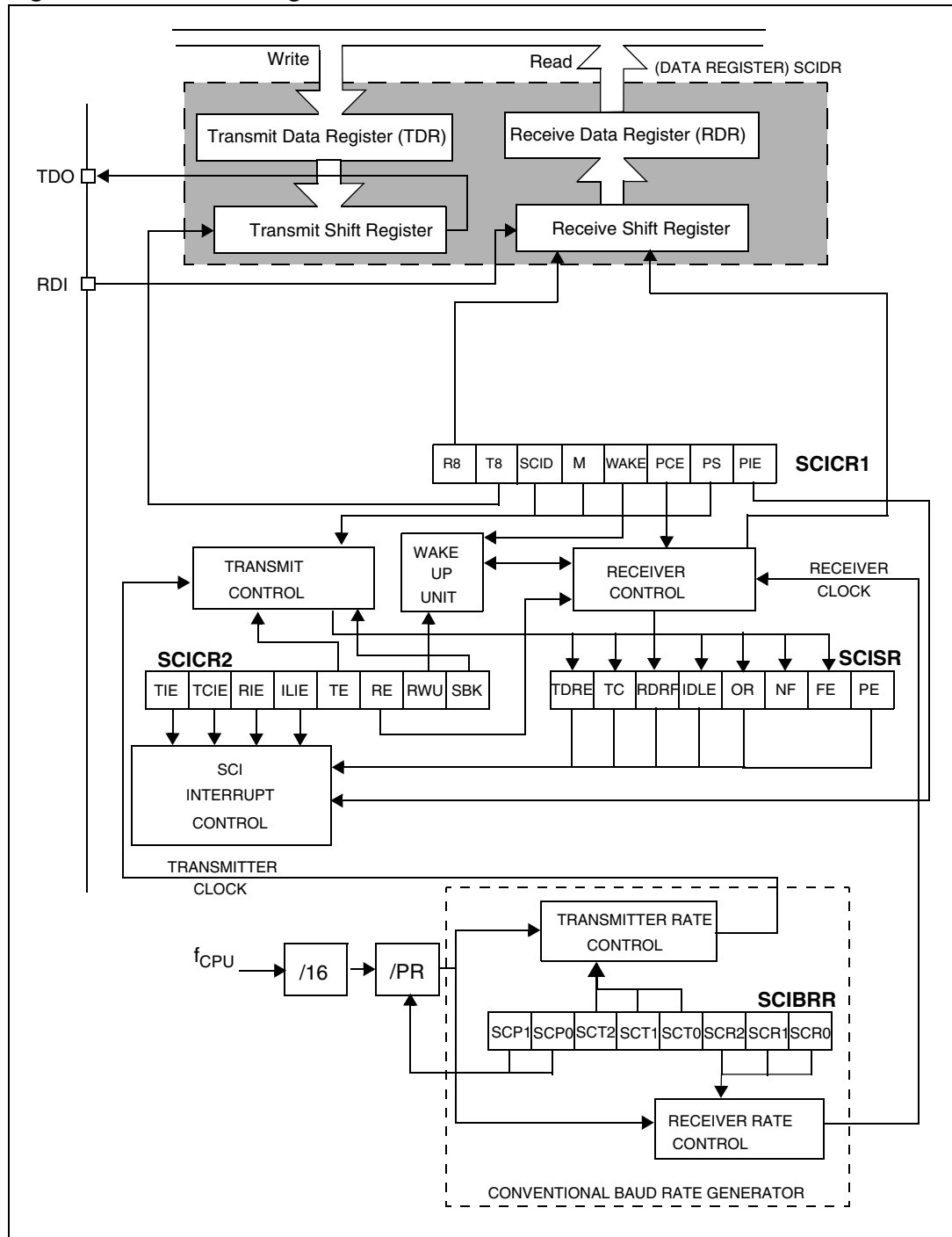

11.5.4 Functional description

The block diagram of the Serial Control Interface, is shown in [Figure 63](#). It contains six dedicated registers:

- 2 control registers (SCICR1 and SCICR2)
- A status register (SCISR)
- A baud rate register (SCIBRR)
- An extended prescaler receiver register (SCIERPR)
- An extended prescaler transmitter register (SCIETPR)

Refer to the register descriptions in [Section 11.5.7](#) for the definitions of each bit.

Serial data format

Word length may be selected as being either 8 or 9 bits by programming the M bit in the SCICR1 register (see [Figure 64](#)).

The TDO pin is in low state during the start bit.

The TDO pin is in high state during the stop bit.

An Idle character is interpreted as an entire frame of “1”s followed by the start bit of the next frame which contains data.

A Break character is interpreted on receiving “0”s for some multiple of the frame period. At the end of the last break frame the transmitter inserts an extra “1” bit to acknowledge the start bit.

Transmission and reception are driven by their own baud rate generator.

Figure 64. Word length programming

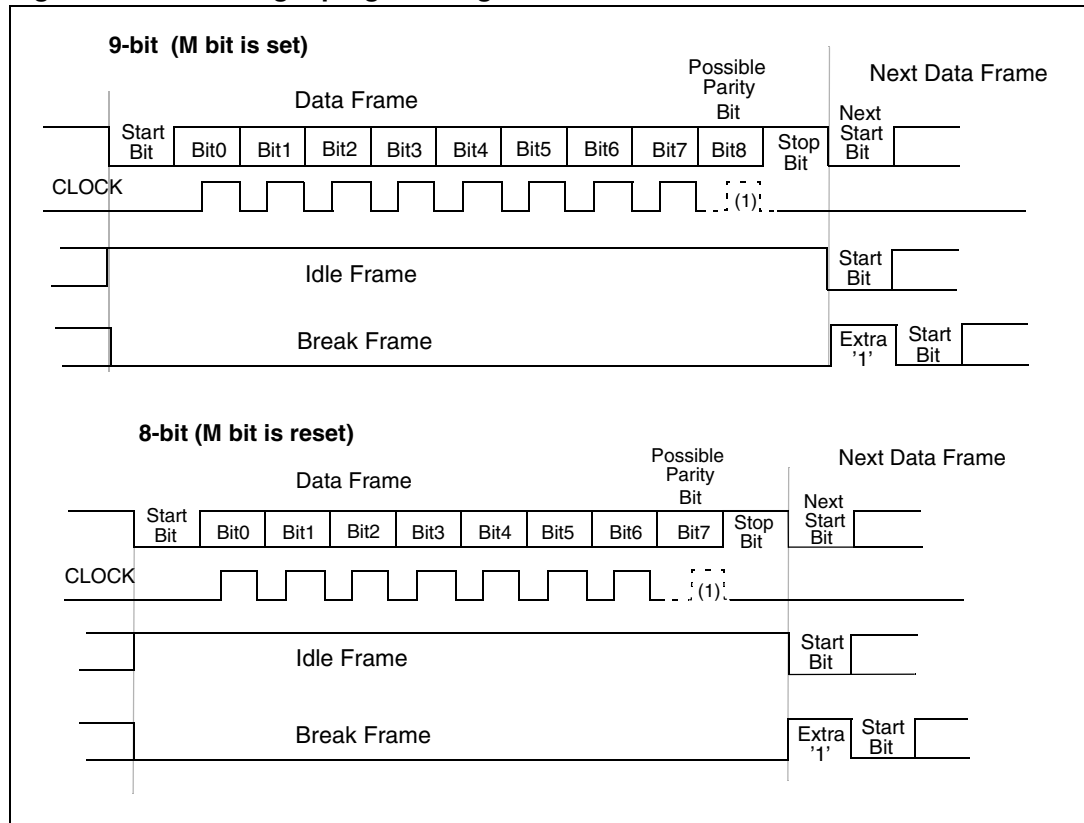

1. LBCL bit controls last data clock pulse.

Transmitter

The transmitter can send data words of either 8 or 9 bits depending on the M bit status. When the M bit is set, word length is 9 bits and the 9th bit (the MSB) has to be stored in the T8 bit in the SCICR1 register.

When the transmit enable bit (TE) is set, the data in the transmit shift register is output on the TDO pin.

Character transmission

During an SCI transmission, data shifts out least significant bit first on the TDO pin. In this mode, the SCIDR register consists of a buffer (TDR) between the internal bus and the transmit shift register (see [Figure 64](#)).

Procedure:

- Select the M bit to define the word length.
- Select the desired baud rate using the SCIBRR and the SCIETPR registers.
- Set the TE bit to send an idle frame as first transmission.
- Access the SCISR register and write the data to send in the SCIDR register (this sequence clears the TDRE bit). Repeat this sequence for each data to be transmitted.

Clearing the TDRE bit is always performed by the following software sequence:

- a) An access to the SCISR register
- b) A write to the SCIDR register

The TDRE bit is set by hardware and it indicates:

- The TDR register is empty.
- The data transfer is beginning.
- The next data can be written in the SCIDR register without overwriting the previous data.

This flag generates an interrupt if the TIE bit is set and the I bit is cleared in the CCR register.

When a transmission is taking place, a write instruction to the SCIDR register stores the data in the TDR register and which is copied in the shift register at the end of the current transmission.

When no transmission is taking place, a write instruction to the SCIDR register places the data directly in the shift register; the data transmission starts, and the TDRE bit is immediately set.

When a frame transmission is complete (after the stop bit or after the break frame) the TC bit is set and an interrupt is generated if the TCIE is set and the I bit is cleared in the CCR register.

Clearing the TC bit is performed by the following software sequence:

- a) An access to the SCISR register
- b) A write to the SCIDR register

Note: The TDRE and TC bits are cleared by the same software sequence.

Break characters

Setting the SBK bit loads the shift register with a break character. The break frame length depends on the M bit (see [Figure 64](#)).

As long as the SBK bit is set, the SCI send break frames to the TDO pin. After clearing this bit by software the SCI insert a logic 1 bit at the end of the last break frame to guarantee the recognition of the start bit of the next frame.

Idle characters

Setting the TE bit drives the SCI to send an idle frame before the first data frame.

Clearing and then setting the TE bit during a transmission sends an idle frame after the current word.

Note: Resetting and setting the TE bit causes the data in the TDR register to be lost. Therefore, the best time to toggle the TE bit is when the TDRE bit is set, that is, before writing the next byte in the SCIDR.

Receiver

The SCI can receive data words of either 8 or 9 bits. When the M bit is set, the word length is 9 bits and the MSB is stored in the R8 bit in the SCICR1 register.

Character reception

During a SCI reception, data shifts in least significant bit first through the RDI pin. In this mode, the SCIDR register consists of a buffer (RDR) between the internal bus and the received shift register (see [Figure 63](#)).

Procedure:

- Select the M bit to define the word length.
- Select the desired baud rate using the SCIBRR and the SCIERPR registers.
- Set the RE bit, this enables the receiver which begins searching for a start bit.

When a character is received:

- The RDRF bit is set. It indicates that the content of the shift register is transferred to the RDR.
- An interrupt is generated if the RIE bit is set and the I bit is cleared in the CCR register.
- The error flags can be set if a frame error, noise or an overrun error has been detected during reception.

Clearing the RDRF bit is performed by the following software sequence done by:

- a) An access to the SCISR register
- b) A read to the SCIDR register.

The RDRF bit must be cleared before the end of the reception of the next character to avoid an overrun error.

Break character

When a break character is received, the SCI handles it as a framing error.

Idle character

When an idle frame is detected, there is the same procedure as a data received character plus an interrupt if the ILIE bit is set and the I bit is cleared in the CCR register.

Overrun error

An overrun error occurs when a character is received and RDRF has not been reset. Data cannot be transferred from the shift register to the RDR register until the RDRF bit is cleared.

When a overrun error occurs:

- The OR bit is set.
- The RDR content is not lost.
- The shift register is overwritten.
- An interrupt is generated if the RIE bit is set and the I bit is cleared in the CCR register.

The OR bit is reset by an access to the SCISR register followed by a SCIDR register read operation.

Noise error

Oversampling techniques are used for data recovery by discriminating between valid incoming data and noise.

Normal data bits are considered valid if three consecutive samples (8th, 9th, 10th) have the same bit value, otherwise the NF flag is set. In the case of start bit detection, the NF flag is set on the basis of an algorithm combining both valid edge detection and three samples (8th, 9th, 10th). Therefore, to prevent the NF flag getting set during start bit reception, there should be a valid edge detection as well as three valid samples.

When noise is detected in a frame:

- The NF flag is set at the rising edge of the RDRF bit.
- Data is transferred from the Shift register to the SCIDR register.
- No interrupt is generated. However this bit rises at the same time as the RDRF bit which itself generates an interrupt.

The NF flag is reset by a SCISR register read operation followed by a SCIDR register read operation.

During reception, if a false start bit is detected (e.g. 8th, 9th, 10th samples are 011,101,110), the frame is discarded and the receiving sequence is not started for this frame. There is no RDRF bit set for this frame and the NF flag is set internally (not accessible to the user). This NF flag is accessible along with the RDRF bit when a next valid frame is received.

Note: If the application Start Bit is not long enough to match the above requirements, then the NF flag may get set due to the short Start Bit. In this case, the NF flag may be ignored by the application software when the first valid byte is received.

See also [Noise error causes](#).

Framing error

A framing error is detected when:

- The stop bit is not recognized on reception at the expected time, following either a de-synchronization or excessive noise.
- A break is received.

When the framing error is detected:

- the FE bit is set by hardware
- Data is transferred from the Shift register to the SCIDR register.
- No interrupt is generated. However this bit rises at the same time as the RDRF bit which itself generates an interrupt.

The FE bit is reset by a SCISR register read operation followed by an SCIDR register read operation.

Figure 65. SCI baud rate and extended prescaler block diagram

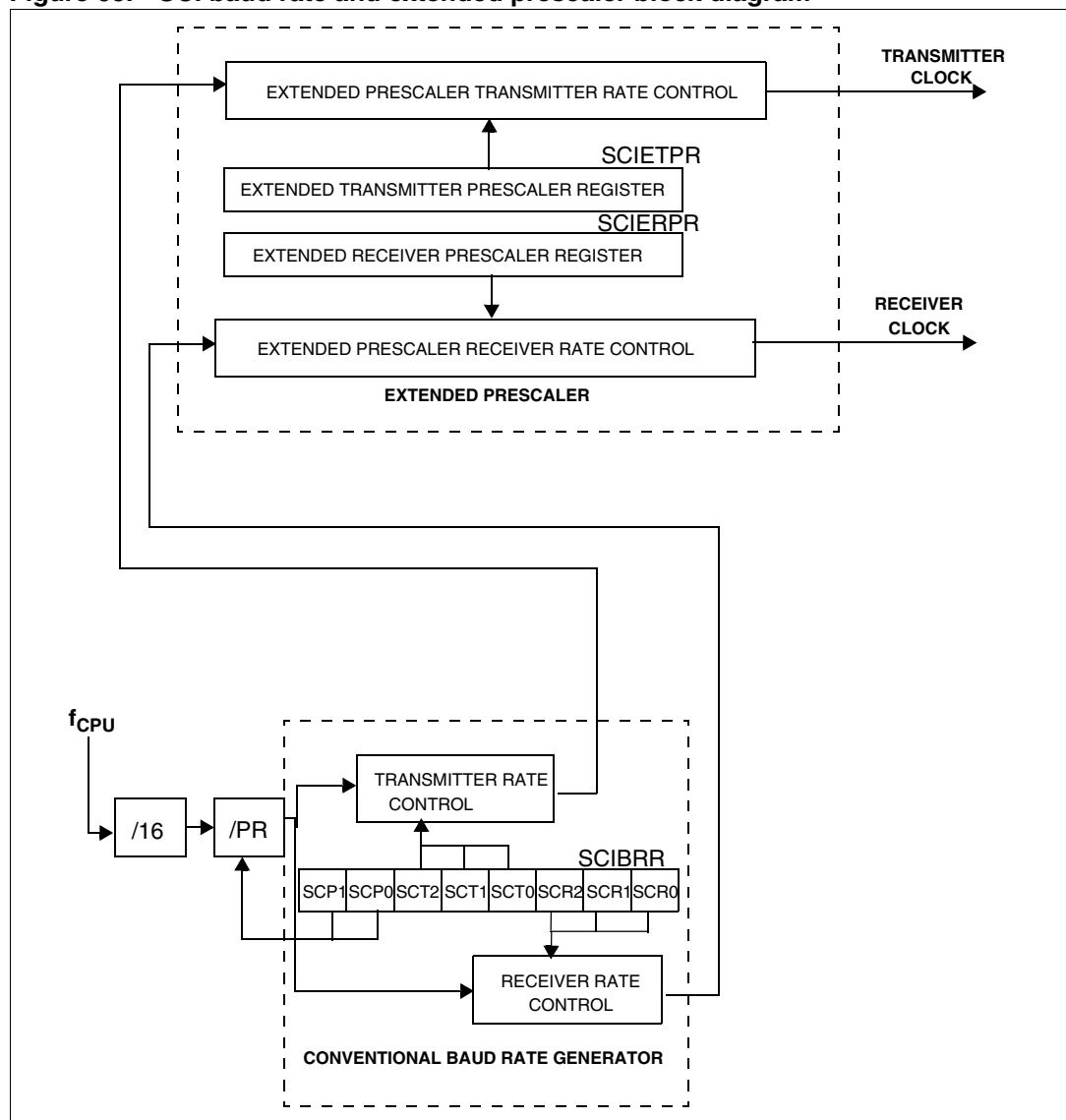

Conventional baud rate generation

The baud rates for the receiver and transmitter (Rx and Tx) are set independently and calculated as follows:

$$Tx = \frac{f_{CPU}}{(16 \cdot PR) \cdot TR} \quad Rx = \frac{f_{CPU}}{(16 \cdot PR) \cdot RR}$$

with:

PR = 1, 3, 4 or 13 (see SCP[1:0] bits)

TR = 1, 2, 4, 8, 16, 32, 64, 128

(see SCT[2:0] bits)

RR = 1, 2, 4, 8, 16, 32, 64, 128

(see SCR[2:0] bits)

All these bits are in the SCIBRR register.

Example: If f_{CPU} is 8 MHz (normal mode) and if PR = 13 and TR = RR = 1, the transmit and receive baud rates are 38400 baud.

Note: The baud rate registers **MUST NOT** be changed while the transmitter or the receiver is enabled.

Extended baud rate generation

The extended prescaler option gives a very fine tuning on the baud rate, using a 255 value prescaler, whereas the conventional Baud Rate Generator retains industry standard software compatibility.

The extended baud rate generator block diagram is shown in [Figure 65](#).

The output clock rate sent to the transmitter or to the receiver is the output from the 16 divider divided by a factor ranging from 1 to 255 set in the SCIETPR or the SCIERPR register.

Note: The extended prescaler is activated by setting the SCIETPR or SCIERPR register to a value other than zero. The baud rates are calculated as follows:

$$Tx = \frac{f_{CPU}}{16 \cdot ETPR \cdot (PR \cdot TR)} \quad Rx = \frac{f_{CPU}}{16 \cdot ERPR \cdot (PR \cdot RR)}$$

with:

ETPR = 1, ..., 255 (see SCIETPR register)

ERPR = 1, ..., 255 (see SCIERPR register)

Receiver muting and wakeup feature

In multiprocessor configurations, it is often desirable that only the intended message recipient should actively receive the full message contents, thus reducing redundant SCI service overhead for all non addressed receivers.

The non-addressed devices may be placed in sleep mode by means of the muting function.

Setting the RWU bit by software puts the SCI in sleep mode:

- None of the reception status bits can be set.
- All the receive interrupts are inhibited.

A muted receiver can be woken up in one of the following two ways:

- by Idle Line detection if the WAKE bit is reset,
- by Address Mark detection if the WAKE bit is set.

A receiver wakes-up by Idle Line detection when the Receive line has recognized an Idle Frame. Then the RWU bit is reset by hardware but the IDLE bit is not set.

A receiver wakes up by Address Mark detection when it received a “1” as the most significant bit of a word, thus indicating that the message is an address. The reception of this particular word wakes up the receiver, resets the RWU bit and sets the RDRF bit, which allows the receiver to receive this word normally and to use it as an address word.

Parity control

Parity control (generation of parity bit in transmission and parity checking in reception) can be enabled by setting the PCE bit in the SCICR1 register. Depending on the frame length defined by the M bit, the possible SCI frame formats are as listed in [Table 56](#).

Table 56. Frame formats

M bit	PCE bit	SCI frame ⁽¹⁾
0	0	SB 8 bit data STB
	1	SB 7-bit data PB STB
1	0	SB 9-bit data STB
	1	SB 8-bit data PB STB

1. SB: Start Bit, STB: Stop Bit, PB: Parity Bit.

Note: In case of wakeup by an address mark, the MSB bit of the data is taken into account and not the parity bit

Even parity: The parity bit is calculated to obtain an even number of “1s” inside the frame made of the 7 or 8 LSB bits (depending on whether M is equal to 0 or 1) and the parity bit.

Example: data = 00110101; 4 bits set => parity bit is 0 if even parity is selected (PS bit = 0).

Odd parity: The parity bit is calculated to obtain an odd number of “1s” inside the frame made of the 7 or 8 LSB bits (depending on whether M is equal to 0 or 1) and the parity bit.

Example: data = 00110101; 4 bits set => parity bit is 1 if odd parity is selected (PS bit = 1).

Transmission mode: If the PCE bit is set, then the MSB bit of the data written in the data register is not transmitted but is changed by the parity bit.

Reception mode: If the PCE bit is set, then the interface checks if the received data byte has an even number of “1s” if even parity is selected (PS = 0) or an odd number of “1s” if odd parity is selected (PS = 1). If the parity check fails, the PE flag is set in the SCISR register and an interrupt is generated if PIE is set in the SCICR1 register.

SCI clock tolerance

During reception, each bit is sampled 16 times. The majority of the 8th, 9th and 10th samples is considered as the bit value. For a valid bit detection, all the three samples should have the same value otherwise the noise flag (NF) is set. For example: if the 8th, 9th and 10th samples are 0, 1 and 1 respectively, then the bit value is "1", but the Noise Flag bit is set because the three samples values are not the same.

Consequently, the bit length must be long enough so that the 8th, 9th and 10th samples have the desired bit value. This means the clock frequency should not vary more than 6/16 (37.5%) within one bit. The sampling clock is resynchronized at each start bit, so that when receiving 10 bits (one start bit, 1 data byte, 1 stop bit), the clock deviation must not exceed 3.75%.

Note: The internal sampling clock of the microcontroller samples the pin value on every falling edge. Therefore, the internal sampling clock and the time the application expects the sampling to take place may be out of sync. For example: If the baud rate is 15.625 kbaud (bit length is 64 μs), then the 8th, 9th and 10th samples will be at 28 μs, 32 μs and 36 μs respectively (the first sample starting ideally at 0 μs). But if the falling edge of the internal clock occurs just before the pin value changes, the samples would then be out of sync by ~4 μs. This means the entire bit length must be at least 40 μs (36 μs for the 10th sample + 4 μs for synchronization with the internal sampling clock).

Clock deviation causes

The causes which contribute to the total deviation are:

- D_{TRA} : Deviation due to transmitter error (Local oscillator error of the transmitter or the transmitter is transmitting at a different baud rate).
- D_{QUANT} : Error due to the baud rate quantization of the receiver.
- D_{REC} : Deviation of the local oscillator of the receiver: This deviation can occur during the reception of one complete SCI message assuming that the deviation has been compensated at the beginning of the message.
- D_{TCL} : Deviation due to the transmission line (generally due to the transceivers)

All the deviations of the system should be added and compared to the SCI clock tolerance:

$$D_{TRA} + D_{QUANT} + D_{REC} + D_{TCL} < 3.75\%$$

Noise error causes

See also description of noise error in [Receiver](#).

- Start bit: the noise flag (NF) is set during start bit reception if one of the following conditions occurs:
 - A valid falling edge is not detected. A falling edge is considered to be valid if the three consecutive samples before the falling edge occurs are detected as '1' and,

- after the falling edge occurs, during the sampling of the 16 samples, if one of the samples numbered 3, 5 or 7 is detected as a “1”.
 - During sampling of the 16 samples, if one of the samples numbered 8, 9 or 10 is detected as a “1”.
- Therefore, a valid Start bit must satisfy both the above conditions to prevent the Noise Flag getting set.
- Data bits: the noise flag (NF) is set during normal data bit reception if the following condition occurs:
 - During the sampling of 16 samples, if all three samples numbered 8, 9 and 10 are not the same. The majority of the 8th, 9th and 10th samples is considered as the bit value.

Therefore, a valid Data bit must have samples 8, 9 and 10 at the same value to prevent the Noise Flag getting set.

Figure 66. Bit sampling in reception mode

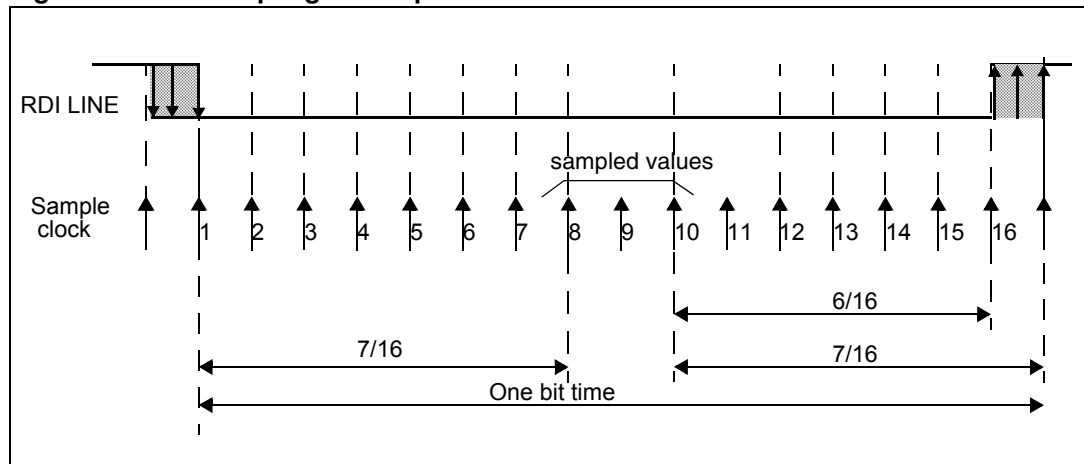

11.5.5 Low-power modes

Table 57. Mode description

Mode	Description
Wait	No effect on SCI. SCI interrupts cause the device to exit from Wait mode.
Halt	SCI registers are frozen. In Halt mode, the SCI stops transmitting/receiving until Halt mode is exited.

11.5.6 Interrupts

Table 58. Interrupt events

Interrupt event	Event flag	Enable control bit	Exit from Wait	Exit from Halt
Transmit data register empty	TDRE	TIE	Yes	No
Transmission complete	TC	TCIE		
Received data ready to be read	RDRF	RIE		
Overrun error detected	OR			
Idle line detected	IDLE	ILIE		
Parity error	PE	PIE		

The SCI interrupt events are connected to the same interrupt vector.

These events generate an interrupt if the corresponding Enable Control Bit is set and the interrupt mask in the CC register is reset (RIM instruction).

11.5.7 Register description

Status register (SCISR)

Reset value: 1100 0000 (C0h)

7							0
TDRE	TC	RDRF	IDLE	OR	NF	FE	PE
Read-only							

Bit 7 = **TDRE** *Transmit data register empty.*

This bit is set by hardware when the content of the TDR register has been transferred into the shift register. An interrupt is generated if the TIE bit = 1 in the SCICR2 register. It is cleared by a software sequence (an access to the SCISR register followed by a write to the SCIDR register).

- 0: Data is not transferred to the shift register
- 1: Data is transferred to the shift register

Note: Data is not transferred to the shift register until the TDRE bit is cleared.

Bit 6 = **TC** *Transmission complete.*

This bit is set by hardware when transmission of a frame containing Data is complete. An interrupt is generated if TCIE = 1 in the SCICR2 register. It is cleared by a software sequence (an access to the SCISR register followed by a write to the SCIDR register).

- 0: Transmission is not complete
- 1: Transmission is complete

Note: TC is not set after the transmission of a Preamble or a Break.

Bit 5 = **RDRF** *Received data ready flag.*

This bit is set by hardware when the content of the RDR register has been transferred to the SCIDR register. An interrupt is generated if RIE = 1 in the SCICR2 register. It is

cleared by a software sequence (an access to the SCISR register followed by a read to the SCIDR register).

0: Data is not received

1: Received data is ready to be read

Bit 4 = IDLE Idle line detect.

This bit is set by hardware when an Idle Line is detected. An interrupt is generated if the ILIE = 1 in the SCICR2 register. It is cleared by a software sequence (an access to the SCISR register followed by a read to the SCIDR register).

0: No Idle Line is detected

1: Idle Line is detected

Note: The IDLE bit is not set again until the RDRF bit has been set itself (that is, a new idle line occurs).

Bit 3 = OR Overrun error.

This bit is set by hardware when the word currently being received in the shift register is ready to be transferred into the RDR register while RDRF = 1. An interrupt is generated if RIE = 1 in the SCICR2 register. It is cleared by a software sequence (an access to the SCISR register followed by a read to the SCIDR register).

0: No Overrun error

1: Overrun error is detected

Note: When this bit is set, the RDR register content is not lost but the shift register is overwritten.

Bit 2 = NF Noise flag.

This bit is set by hardware when noise is detected on a received frame. It is cleared by a software sequence (an access to the SCISR register followed by a read to the SCIDR register).

0: No noise is detected

1: Noise is detected

Note: This bit does not generate interrupt as it appears at the same time as the RDRF bit which itself generates an interrupt.

Bit 1 = FE Framing error.

This bit is set by hardware when a desynchronization, excessive noise or a break character is detected. It is cleared by a software sequence (an access to the SCISR register followed by a read to the SCIDR register).

0: No Framing error is detected

1: Framing error or break character is detected

Note: This bit does not generate an interrupt as it appears at the same time as the RDRF bit which itself generates an interrupt. If the word currently being transferred causes both frame error and overrun error, it is transferred and only the OR bit is set.

Bit 0 = PE Parity error.

This bit is set by hardware when a parity error occurs in receiver mode. It is cleared by a software sequence (a read to the status register followed by an access to the SCIDR data register). An interrupt is generated if PIE = 1 in the SCICR1 register.

0: No parity error

1: Parity error

Control register 1 (SCICR1)

Reset value: x000 0000 (x0h)

7							0
R8	T8	SCID	M	WAKE	PCE	PS	PIE
Read/Write							

Bit 7 = **R8** *Receive data bit 8.*

This bit is used to store the 9th bit of the received word when M = 1.

Bit 6 = **T8** *Transmit data bit 8.*

This bit is used to store the 9th bit of the transmitted word when M = 1.

Bit 5 = **SCID** *Disabled for low power consumption*

When this bit is set the SCI prescalers and outputs are stopped and the end of the current byte transfer in order to reduce power consumption. This bit is set and cleared by software.

0: SCI enabled

1: SCI prescaler and outputs disabled

Bit 4 = **M** *Word length.*

This bit determines the word length. It is set or cleared by software.

0: 1 Start bit, 8 Data bits, 1 Stop bit

1: 1 Start bit, 9 Data bits, 1 Stop bit

Note: The M bit must not be modified during a data transfer (both transmission and reception).

Bit 3 = **WAKE** *Wake-up method.*

This bit determines the SCI Wake-Up method, it is set or cleared by software.

0: Idle Line

1: Address Mark

Bit 2 = **PCE** *Parity control enable.*

This bit selects the hardware parity control (generation and detection). When the parity control is enabled, the computed parity is inserted at the MSB position (9th bit if M = 1; 8th bit if M = 0) and parity is checked on the received data. This bit is set and cleared by software. Once it is set, PCE is active after the current byte (in reception and in transmission).

0: Parity control disabled

1: Parity control enabled

Bit 1 = **PS** *Parity selection.*

This bit selects the odd or even parity when the parity generation/detection is enabled (PCE bit set). It is set and cleared by software. The parity is selected after the current byte.

0: Even parity

1: Odd parity

Bit 0 = **PIE** *Parity interrupt enable.*

This bit enables the interrupt capability of the hardware parity control when a parity error is detected (PE bit set). It is set and cleared by software.

- 0: Parity error interrupt disabled
- 1: Parity error interrupt enabled

Control register 2 (SCICR2)

Reset value: 0000 0000 (00h)

7							0
TIE	TCIE	RIE	ILIE	TE	RE	RWU	SBK
Read/Write							

Bit 7 = **TIE** *Transmitter interrupt enable.*

This bit is set and cleared by software.

- 0: Interrupt is inhibited
- 1: An SCI interrupt is generated whenever TDRE = 1 in the SCISR register

Bit 6 = **TCIE** *Transmission complete interrupt enable*

This bit is set and cleared by software.

- 0: Interrupt is inhibited
- 1: An SCI interrupt is generated whenever TC = 1 in the SCISR register

Bit 5 = **RIE** *Receiver interrupt enable.*

This bit is set and cleared by software.

- 0: Interrupt is inhibited
- 1: An SCI interrupt is generated whenever OR = 1 or RDRF = 1 in the SCISR register

Bit 4 = **ILIE** *Idle line interrupt enable.*

This bit is set and cleared by software.

- 0: Interrupt is inhibited
- 1: An SCI interrupt is generated whenever IDLE = 1 in the SCISR register.

Bit 3 = **TE** *Transmitter enable.*

This bit enables the transmitter. It is set and cleared by software.

- 0: Transmitter is disabled
- 1: Transmitter is enabled

Note: During transmission, a "0" pulse on the TE bit ("0" followed by "1") sends a preamble (idle line) after the current word.

When TE is set there is a 1 bit-time delay before the transmission starts.

Bit 2 = **RE** *Receiver enable.*

This bit enables the receiver. It is set and cleared by software.

- 0: Receiver is disabled
- 1: Receiver is enabled and begins searching for a start bit

Bit 1 = **RWU** Receiver wake-up.

This bit determines if the SCI is in mute mode or not. It is set and cleared by software and can be cleared by hardware when a wake-up sequence is recognized.

- 0: Receiver in active mode
- 1: Receiver in mute mode

Note: Before selecting Mute mode (by setting the RWU bit), the SCI must first receive a data byte; otherwise, it cannot function in Mute mode with wake-up by Idle line detection.

In Address Mark Detection Wake-Up configuration (WAKE bit = 1), the RWU bit cannot be modified by software while the RDRF bit is set.

Bit 0 = **SBK** Send break.

This bit set is used to send break characters. It is set and cleared by software.

- 0: No break character is transmitted
- 1: Break characters are transmitted

Note: If the SBK bit is set to "1" and then to "0", the transmitter sends a BREAK word at the end of the current word.

Data register (SCIDR)

Reset value: Undefined

Contains the Received or Transmitted data character, depending on whether it is read from or written to.

7									0
DR7	DR6	DR5	DR4	DR3	DR2	DR1	DR0		
Read/Write									

The Data register performs a double function (read and write) since it is composed of two registers, one for transmission (TDR) and one for reception (RDR).

The TDR register provides the parallel interface between the internal bus and the output shift register (see [Figure 63](#)).

The RDR register provides the parallel interface between the input shift register and the internal bus (see [Figure 63](#)).

Baud rate register (SCIBRR)

Reset value: 0000 0000 (00h)

7									0
SCP1	SCP0	SCT2	SCT1	SCT0	SCR2	SCR1	SCR0		
Read/Write									

Bits 7:6 = **SCP[1:0]** First SCI Prescaler

These 2 prescaling bits allow several standard clock division ranges as shown in [Figure 59](#).

Table 59. SCP[1:0] configuration

PR prescaling factor	SCP1	SCP0
1	0	0
3		1
4	1	0
13		1

Bits 5:3 = **SCT[2:0]** *SCI Transmitter rate divisor*

These 3 bits, in conjunction with the SCP1 and SCP0 bits, define the total division applied to the bus clock to yield the transmit rate clock in conventional baud rate Generator mode.

Table 60. SCT[2:0] configuration

TR dividing factor	SCT2	SCT1	SCT0
1	0	0	0
2			1
4		1	0
8			1
16	1	0	0
32			1
64		1	0
128			1

Note: This TR factor is used only when the ETPR fine tuning factor is equal to 00h; otherwise, TR is replaced by the (TR*ETPR) dividing factor.

Bits 2:0 = **SCR[2:0]** *SCI Receiver rate divisor.*

These 3 bits, in conjunction with the SCP1 and SCP0 bits, define the total division applied to the bus clock to yield the receive rate clock in conventional Baud Rate Generator mode.

Table 61. SCR[2:0] configuration

RR dividing factor	SCR2	SCR1	SCR0
1	0	0	0
2			1
4		1	0
8			1
16	1	0	0
32			1
64		1	0
128			1

Note: This RR factor is used only when the ERPR fine tuning factor is equal to 00h; otherwise, RR is replaced by the (RR*ERPR) dividing factor.

Extended receive prescaler division register (SCIERPR)

Reset value: 0000 0000 (00h)

7							0
ERPR7	ERPR6	ERPR5	ERPR4	ERPR3	ERPR2	ERPR1	ERPR0
Read/Write							

Bits 7:0 = **ERPR[7:0]** 8-bit Extended Receive Prescaler Register.

The extended Baud Rate Generator is activated when a value other than 00h is stored in this register. The clock frequency from the 16 divider (see [Figure 65](#)) is divided by the binary factor set in the SCIERPR register (in the range 1 to 255).

The extended baud rate generator is not active after a reset.

Extended transmit prescaler division register (SCIETPR)

Reset value:0000 0000 (00h)

7							0
ETPR7	ETPR6	ETPR5	ETPR4	ETPR3	ETPR2	ETPR1	ETPR0
Read/Write							

Bits 7:0 = **ETPR[7:0]** 8-bit extended transmit prescaler register.

The extended Baud Rate Generator is activated when a value other than 00h is stored in this register. The clock frequency from the 16 divider (see [Figure 65](#)) is divided by the binary factor set in the SCIETPR register (in the range 1 to 255).

The extended baud rate generator is not active after a reset.

Table 62. Baud rate selection

Symbol	Parameter	Conditions			Standard	Baud Rate	Unit
		f _{CPU}	Accuracy vs. Standard	Prescaler			
f _{Tx} f _{Rx}	Communication frequency	8 MHz	~0.16%	Conventional Mode TR (or RR) = 128, PR = 13 TR (or RR) = 32, PR = 13 TR (or RR) = 16, PR = 13 TR (or RR) = 8, PR = 13 TR (or RR) = 4, PR = 13 TR (or RR) = 16, PR = 3 TR (or RR) = 2, PR = 13 TR (or RR) = 1, PR = 13	300 1200 2400 4800 9600 10400 19200 38400	~300.48 ~1201.92 ~2403.84 ~4807.69 ~9615.38 ~10416.67 ~19230.77 ~38461.54	Hz
			~0.79%	Extended Mode ETPR (or ERPR) = 35, TR (or RR) = 1, PR = 1	14400	~14285.71	

Table 63. SCI register map and reset values

Address (Hex.)	Register Label	7	6	5	4	3	2	1	0
0050h	SCISR Reset value	TDRE 1	TC 1	RDRF 0	IDLE 0	OR 0	NF 0	FE 0	PE 0
0051h	SCIDR Reset value	MSB x	x	x	x	x	x	x	LSB x
0052h	SCIBRR Reset value	SCP1 0	SCP0 0	SCT2 0	SCT1 0	SCT0 0	SCR2 0	SCR1 0	SCR0 0
0053h	SCICR1 Reset value	R8 x	T8 0	SCID 0	M 0	WAKE 0	PCE 0	PS 0	PIE 0
0054h	SCICR2 Reset value	TIE 0	TCIE 0	RIE 0	ILIE 0	TE 0	RE 0	RWU 0	SBK 0
0056h	SCIERPR Reset value	MSB 0	0	0	0	0	0	0	LSB 0
0057h	SCIPETPR Reset value	MSB 0	0	0	0	0	0	0	LSB 0

11.6 I²C bus interface (I2C)

11.6.1 Introduction

The I²C bus interface serves as an interface between the microcontroller and the serial I²C bus. It provides both multimaster and slave functions, and controls all I²C bus-specific sequencing, protocol, arbitration and timing. It supports fast I²C mode (400 kHz).

11.6.2 Main features

- Parallel-bus/I²C protocol converter
- Multi-master capability
- 7-bit/10-bit Addressing
- Transmitter/Receiver flag
- End-of-byte transmission flag
- Transfer problem detection

I²C master features

- Clock generation
- I²C bus busy flag
- Arbitration lost flag
- End of byte transmission flag
- Transmitter/receiver flag
- Start bit detection flag
- Start and Stop generation

I²C slave features

- Stop bit detection
- I²C bus busy flag
- Detection of misplaced start or stop condition
- Programmable I²C address detection
- Transfer problem detection
- End-of-byte transmission flag
- Transmitter/receiver flag

11.6.3 General description

In addition to receiving and transmitting data, this interface converts it from serial to parallel format and vice versa, using either an interrupt or polled handshake. The interrupts are enabled or disabled by software. The interface is connected to the I²C bus by a data pin (SDAI) and by a clock pin (SCLI). It can be connected both with a standard I²C bus and a Fast I²C bus. This selection is made by software.

Mode selection

The interface can operate in the four following modes:

- Slave transmitter/receiver
- Master transmitter/receiver

By default, it operates in slave mode.

The interface automatically switches from slave to master after it generates a START condition, and from master to slave in case of an arbitration loss or a STOP generation, allowing then Multi-Master capability.

Communication flow

In Master mode, it initiates a data transfer and generates the clock signal. A serial data transfer always begins with a start condition and ends with a stop condition. Both start and stop conditions are generated in master mode by software.

In Slave mode, the interface is capable of recognizing its own address (7 or 10-bit), and the General Call address. The General Call address detection may be enabled or disabled by software.

Data and addresses are transferred as 8-bit bytes, MSB first. The first byte(s) following the start condition contain the address (one in 7-bit mode, two in 10-bit mode). The address is always transmitted in Master mode.

A 9th clock pulse follows the 8 clock cycles of a byte transfer, during which the receiver must send an acknowledge bit to the transmitter. Refer to [Figure 67](#).

Figure 67. I²C bus protocol

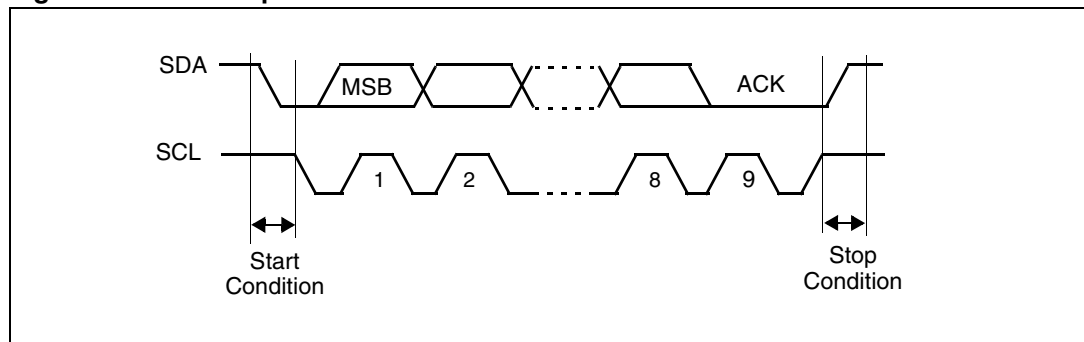

Acknowledge may be enabled and disabled by software.

The I²C interface address and/or general call address can be selected by software.

The speed of the I²C interface may be selected between Standard (up to 100 kHz) and Fast I²C (up to 400 kHz).

SDA/SCL line control

- Transmitter mode: the interface holds the clock line low before transmission to wait for the microcontroller to write the byte in the Data Register.
- Receiver mode: the interface holds the clock line low after reception to wait for the microcontroller to read the byte in the Data Register.

The SCL frequency (f_{SCL}) is controlled by a programmable clock divider which depends on the I²C bus mode.

When the I²C cell is enabled, the SDA and SCL ports must be configured as floating inputs. In this case, the value of the external pull-up resistor used depends on the application. When the I²C cell is disabled, the SDA and SCL ports revert to being standard I/O port pins.

Figure 68. I²C interface block diagram

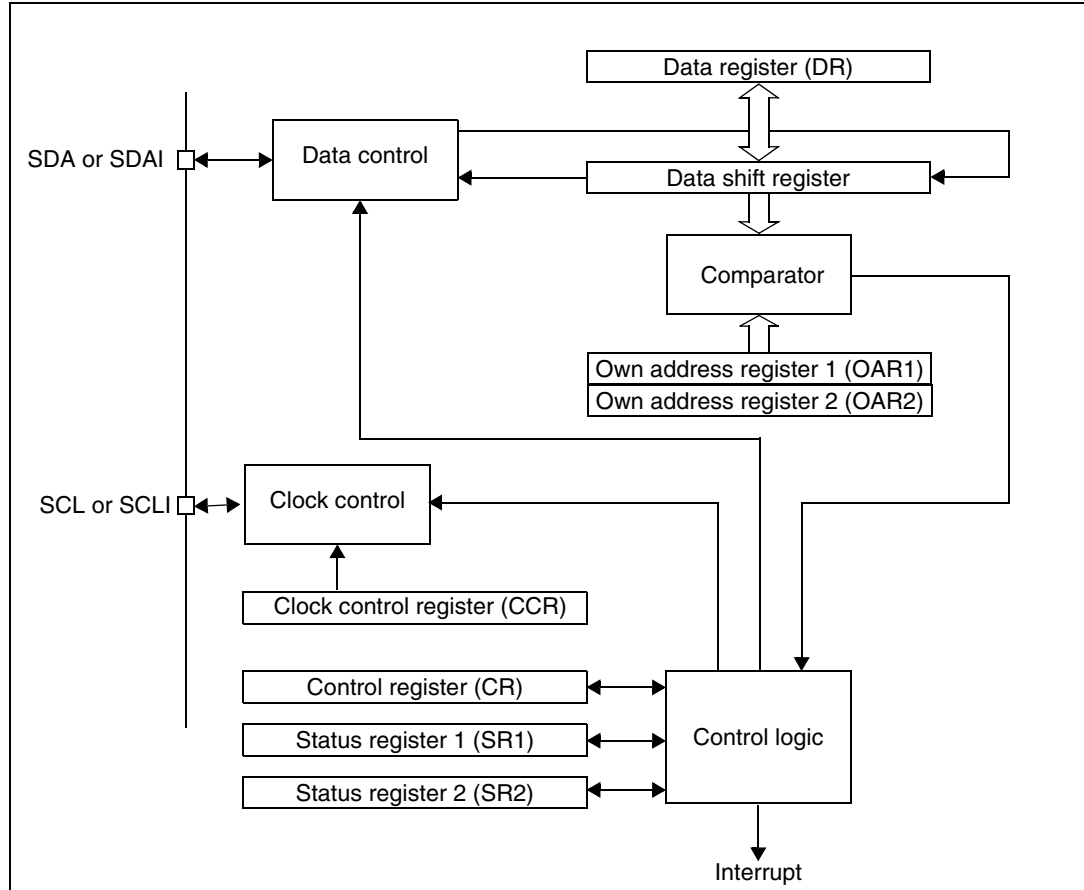

11.6.4 Functional description

Refer to the CR, SR1 and SR2 registers in [Section 11.6.7](#) for the bit definitions.

By default the I²C interface operates in Slave mode (M/SL bit is cleared) except when it initiates a transmit or receive sequence.

First the interface frequency must be configured using the FRi bits in the OAR2 register.

Slave mode

As soon as a start condition is detected, the address is received from the SDA line and sent to the shift register; then it is compared with the address of the interface or the General Call address (if selected by software).

Note: In 10-bit addressing mode, the comparison includes the header sequence (11110xx0) and the two most significant bits of the address.

Header matched (10-bit mode only): the interface generates an acknowledge pulse if the ACK bit is set.

Address not matched: the interface ignores it and waits for another Start condition.

Address matched: the interface generates in sequence:

- Acknowledge pulse if the ACK bit is set.
- EVF and ADSL bits are set with an interrupt if the ITE bit is set.

Then the interface waits for a read of the SR1 register, **holding the SCL line low** (see [Figure 69](#) Transfer sequencing EV1).

Next, in 7-bit mode read the DR register to determine from the least significant bit (Data Direction Bit) if the slave must enter Receiver or Transmitter mode.

In 10-bit mode, after receiving the address sequence the slave is always in receive mode. It will enter transmit mode on receiving a repeated Start condition followed by the header sequence with matching address bits and the least significant bit set (11110xx1).

Slave receiver

Following the address reception and after SR1 register has been read, the slave receives bytes from the SDA line into the DR register via the internal shift register. After each byte the interface generates in sequence:

- Acknowledge pulse if the ACK bit is set
- EVF and BTF bits are set with an interrupt if the ITE bit is set.

Then the interface waits for a read of the SR1 register followed by a read of the DR register, **holding the SCL line low** (see [Figure 69](#) Transfer sequencing EV2).

Slave transmitter

Following the address reception and after SR1 register has been read, the slave sends bytes from the DR register to the SDA line via the internal shift register.

The slave waits for a read of the SR1 register followed by a write in the DR register, **holding the SCL line low** (see [Figure 69](#) Transfer sequencing EV3).

When the acknowledge pulse is received:

- The EVF and BTF bits are set by hardware with an interrupt if the ITE bit is set.

Closing slave communication

After the last data byte is transferred a Stop Condition is generated by the master. The interface detects this condition and sets:

- EVF and STOPF bits with an interrupt if the ITE bit is set.

Then the interface waits for a read of the SR2 register (see [Figure 69](#) Transfer sequencing EV4).

Error cases

- **BERR:** Detection of a Stop or a Start condition during a byte transfer. In this case, the EVF and the BERR bits are set with an interrupt if the ITE bit is set.
If it is a Stop, then the interface discards the data, released the lines and waits for another Start condition.
If it is a Start, then the interface discards the data and waits for the next slave address on the bus.
- **AF:** Detection of a non-acknowledge bit. In this case, the EVF and AF bits are set with an interrupt if the ITE bit is set.
The AF bit is cleared by reading the I2CSR2 register. However, if read before the completion of the transmission, the AF flag will be set again, thus possibly generating a

new interrupt. Software must ensure either that the SCL line is back at 0 before reading the SR2 register, or be able to correctly handle a second interrupt during the 9th pulse of a transmitted byte.

Note: In both cases, SCL line is not held low; however, the SDA line can remain low if the last bits transmitted are all 0. It is then necessary to release both lines by software. The SCL line is not held low while AF=1 but by other flags (SB or BTF) that are set at the same time.

How to release the SDA / SCL lines

Set and subsequently clear the STOP bit while BTF is set. The SDA/SCL lines are released after the transfer of the current byte.

SMBus compatibility

ST7 I²C is compatible with SMBus V1.1 protocol. It supports all SMBus addressing modes, SMBus bus protocols and CRC-8 packet error checking. Refer to AN1713: SMBus Slave Driver For ST7 I²C Peripheral.

Master mode

To switch from default Slave mode to Master mode a Start condition generation is needed.

Start condition

Setting the START bit while the BUSY bit is cleared causes the interface to switch to Master mode (M/SL bit set) and generates a Start condition.

Once the Start condition is sent:

- The EVF and SB bits are set by hardware with an interrupt if the ITE bit is set.

Then the master waits for a read of the SR1 register followed by a write in the DR register with the Slave address, **holding the SCL line low** (see [Figure 69](#) Transfer sequencing EV5).

Slave address transmission

Then the slave address is sent to the SDA line via the internal shift register.

In 7-bit addressing mode, one address byte is sent.

In 10-bit addressing mode, sending the first byte including the header sequence causes the following event:

- The EVF bit is set by hardware with interrupt generation if the ITE bit is set.

Then the master waits for a read of the SR1 register followed by a write in the DR register, **holding the SCL line low** (see [Figure 69](#) Transfer sequencing EV9).

Then the second address byte is sent by the interface.

After completion of this transfer (and acknowledge from the slave if the ACK bit is set):

- The EVF bit is set by hardware with interrupt generation if the ITE bit is set.

Then the master waits for a read of the SR1 register followed by a write in the CR register (for example set PE bit), **holding the SCL line low** (see [Figure 69](#) Transfer sequencing EV6).

Next the master must enter Receiver or Transmitter mode.

Note: In 10-bit addressing mode, to switch the master to Receiver mode, the software must generate a repeated Start condition and resend the header sequence with the least significant bit set (11110xx1).

Master receiver

Following the address transmission and after SR1 and CR registers have been accessed, the master receives bytes from the SDA line into the DR register via the internal shift register. After each byte the interface generates in sequence:

- Acknowledge pulse if the ACK bit is set
- EVF and BTF bits are set by hardware with an interrupt if the ITE bit is set.

Then the interface waits for a read of the SR1 register followed by a read of the DR register, **holding the SCL line low** (see [Figure 69](#) Transfer sequencing EV7).

To close the communication: before reading the last byte from the DR register, set the STOP bit to generate the Stop condition. The interface goes automatically back to slave mode (M/SL bit cleared).

Note: In order to generate the non-acknowledge pulse after the last received data byte, the ACK bit must be cleared just before reading the second last data byte.

Master transmitter

Following the address transmission and after SR1 register has been read, the master sends bytes from the DR register to the SDA line via the internal shift register.

The master waits for a read of the SR1 register followed by a write in the DR register, **holding the SCL line low** (see [Figure 69](#) Transfer sequencing EV8).

When the acknowledge bit is received, the interface sets:

- EVF and BTF bits with an interrupt if the ITE bit is set.

To close the communication: after writing the last byte to the DR register, set the STOP bit to generate the Stop condition. The interface goes automatically back to slave mode (M/SL bit cleared).

Error cases

- **BERR:** Detection of a Stop or a Start condition during a byte transfer. In this case, the EVF and BERR bits are set by hardware with an interrupt if ITE is set. Note that BERR will not be set if an error is detected during the first pulse of each 9-bit transaction:

Single Master Mode

If a Start or Stop is issued during the first pulse of a 9-bit transaction, the BERR flag will not be set and transfer will continue however the BUSY flag will be reset. To work around this, slave devices should issue a NACK when they receive a misplaced Start or Stop. The reception of a NACK or BUSY by the master in the middle of communication gives the possibility to re-initiate transmission.

Multimaster Mode

Normally the BERR bit would be set whenever unauthorized transmission takes place while transfer is already in progress. However, an issue will arise if an external master generates an unauthorized Start or Stop while the I²C master is on the first pulse of a 9-bit transaction. It is possible to work around this by polling the BUSY bit during I²C

master mode transmission. The resetting of the BUSY bit can then be handled in a similar manner as the BERR flag being set.

- **AF:** Detection of a non-acknowledge bit. In this case, the EVF and AF bits are set by hardware with an interrupt if the ITE bit is set. To resume, set the Start or Stop bit. The AF bit is cleared by reading the I2CSR2 register. However, if read before the completion of the transmission, the AF flag will be set again, thus possibly generating a new interrupt. Software must ensure either that the SCL line is back at 0 before reading the SR2 register, or be able to correctly handle a second interrupt during the 9th pulse of a transmitted byte.
- **ARLO:** Detection of an arbitration lost condition.
In this case the ARLO bit is set by hardware (with an interrupt if the ITE bit is set and the interface goes automatically back to slave mode (the M/SL bit is cleared).

Note: In all these cases, the SCL line is not held low; however, the SDA line can remain low if the last bits transmitted are all 0. It is then necessary to release both lines by software. The SCL line is not held low while AF=1 but by other flags (SB or BTF) that are set at the same time.

Figure 69. Transfer sequencing

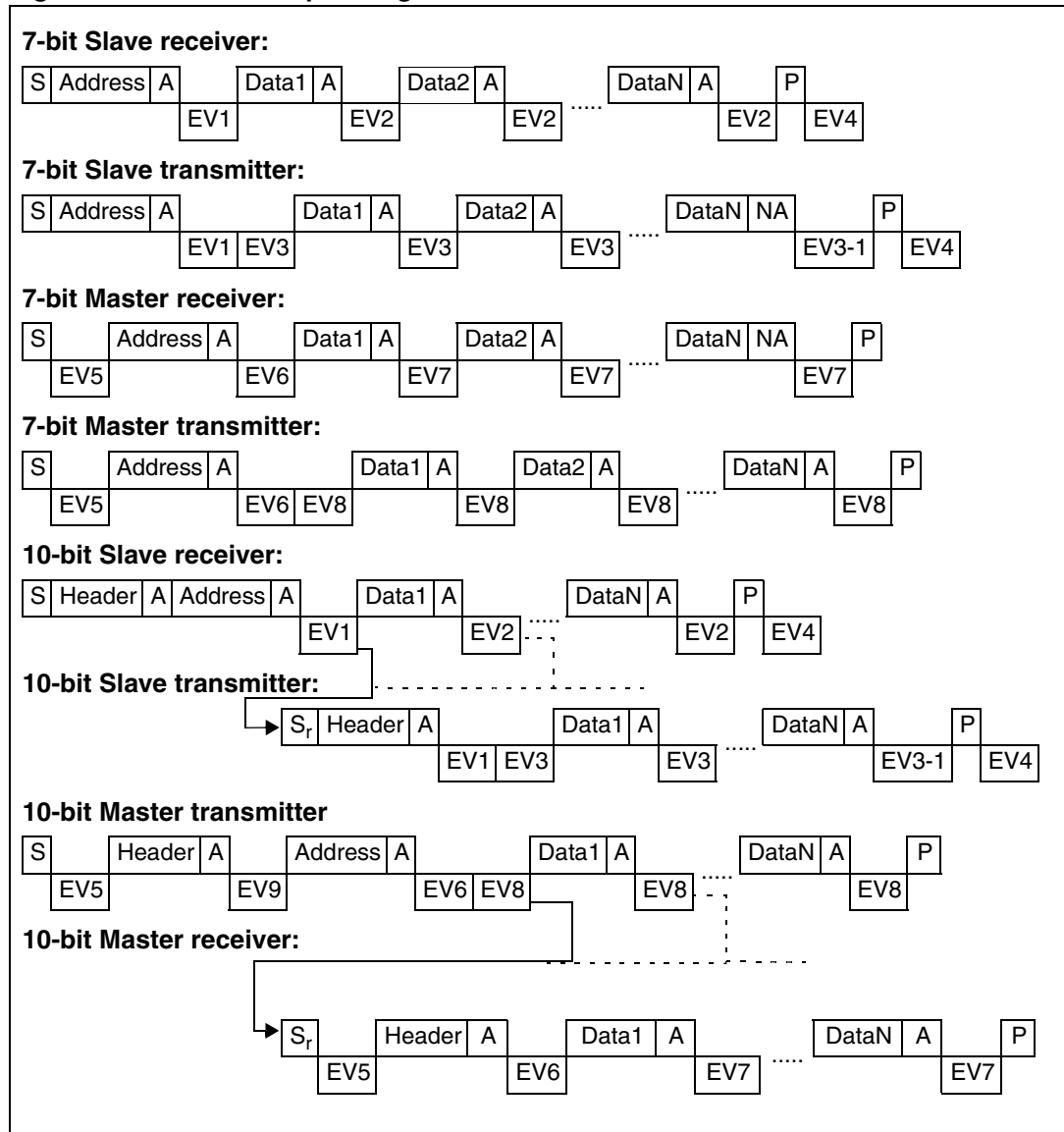

Legend: S = Start, S_r = Repeated Start, P = Stop, A = Acknowledge, NA = Non-acknowledge, EVx = Event (with interrupt if ITE=1)

EV1: EVF=1, ADSL=1, cleared by reading SR1 register.

EV2: EVF=1, BTF=1, cleared by reading SR1 register followed by reading DR register.

EV3: EVF=1, BTF=1, cleared by reading SR1 register followed by writing DR register.

EV3-1: EVF=1, AF=1, BTF=1; AF is cleared by reading SR1 register. BTF is cleared by releasing the lines (STOP=1, STOP=0) or by writing DR register (DR=FFh).

Note: If lines are released by STOP=1, STOP=0, the subsequent EV4 is not seen.

EV4: EVF=1, STOPF=1, cleared by reading SR2 register.

EV5: EVF=1, SB=1, cleared by reading SR1 register followed by writing DR register.

EV6: EVF=1, cleared by reading SR1 register followed by writing CR register (for example PE=1).

EV7: EVF=1, BTF=1, cleared by reading SR1 register followed by reading DR register.

EV8: EVF=1, BTF=1, cleared by reading SR1 register followed by writing DR register.

EV9: EVF=1, ADD10=1, cleared by reading SR1 register followed by writing DR register.

11.6.5 Low-power modes

Table 64. Mode description

Mode	Description
Wait	No effect on I ² C interface. I ² C interrupts cause the device to exit from Wait mode.
Halt	I ² C registers are frozen. In HALT mode, the I ² C interface is inactive and does not acknowledge data on the bus. The I ² C interface resumes operation when the MCU is woken up by an interrupt with “exit from HALT mode” capability.

11.6.6 Interrupts

Figure 70. Event flags and interrupt generation

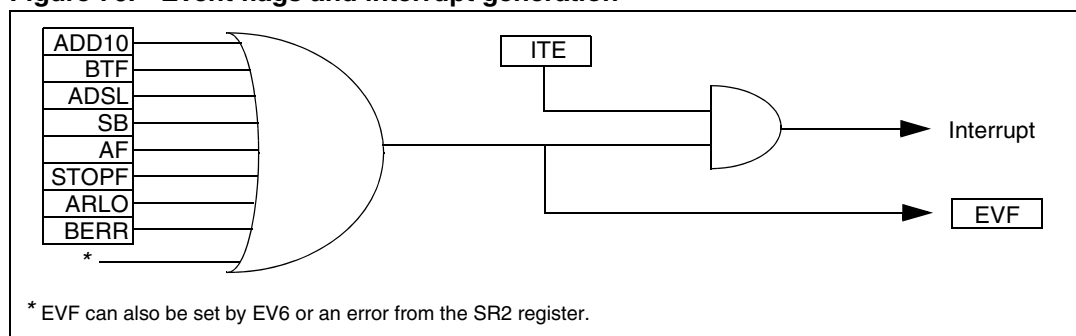

Table 65. Interrupt events (1)

Interrupt event	Event flag	Enable control bit	Exit from Wait	Exit from Halt
10-bit address sent event (Master mode)	ADD10	ITE	Yes	No
End of byte transfer event	BTF		Yes	No
Address matched event (Slave mode)	ADSL		Yes	No
Start bit generation event (Master mode)	SB		Yes	No
Acknowledge failure event	AF		Yes	No
Stop detection event (Slave mode)	STOPF		Yes	No
Arbitration lost event (Multimaster configuration)	ARLO		Yes	No
Bus error event	BERR		Yes	No

1. The I²C interrupt events are connected to the same interrupt vector (see [Section 8: Interrupts](#)). They generate an interrupt if the corresponding Enable Control Bit is set and the I-bit in the CC register is reset (RIM instruction).

11.6.7 Register description

I²C control register (CR)

Reset value: 0000 0000 (00h)

7							0
0	0	PE	ENGC	START	ACK	STOP	ITE
Read / Write							

Bits 7:6 = Reserved. Forced to 0 by hardware.

Bit 5 = **PE** *Peripheral enable*.

This bit is set and cleared by software.

0: Peripheral disabled

1: Master/Slave capability

Note: When PE=0, all the bits of the CR register and the SR register except the Stop bit are reset. All outputs are released while PE=0

When PE=1, the corresponding I/O pins are selected by hardware as alternate functions.

To enable the I²C interface, write the CR register **TWICE** with PE=1 as the first write only activates the interface (only PE is set).

Bit 4 = **ENGC** *Enable General Call*.

This bit is set and cleared by software. It is also cleared by hardware when the interface is disabled (PE=0). The 00h General Call address is acknowledged (01h ignored).

0: General Call disabled

1: General Call enabled

Note: In accordance with the I2C standard, when GCAL addressing is enabled, an I2C slave can only receive data. It will not transmit data to the master.

Bit 3 = **START** *Generation of a Start condition*.

This bit is set and cleared by software. It is also cleared by hardware when the interface is disabled (PE=0) or when the Start condition is sent (with interrupt generation if ITE=1).

- In master mode:
 - 0: No start generation
 - 1: Repeated start generation
- In slave mode:
 - 0: No start generation
 - 1: Start generation when the bus is free

Bit 2 = **ACK** *Acknowledge enable.*

This bit is set and cleared by software. It is also cleared by hardware when the interface is disabled (PE=0).

0: No acknowledge returned

1: Acknowledge returned after an address byte or a data byte is received

Bit 1 = **STOP** *Generation of a Stop condition.*

This bit is set and cleared by software. It is also cleared by hardware in master mode.

Note: This bit is not cleared when the interface is disabled (PE=0).

- In master mode:
 - 0: No stop generation
 - 1: Stop generation after the current byte transfer or after the current Start condition is sent. The STOP bit is cleared by hardware when the Stop condition is sent.
- In slave mode:
 - 0: No stop generation
 - 1: Release the SCL and SDA lines after the current byte transfer (BTF=1). In this mode the STOP bit has to be cleared by software.

Bit 0 = **ITE** *Interrupt enable.*

This bit is set and cleared by software and cleared by hardware when the interface is disabled (PE=0).

0: Interrupts disabled

1: Interrupts enabled

Refer to [Figure 70](#) for the relationship between the events and the interrupt.

SCL is held low when the ADD10, SB, BTF or ADSL flags or an EV6 event (See [Figure 69](#)) is detected.

I²C status register 1 (SR1)

Reset value: 0000 0000 (00h)

7							0
EVF	ADD10	TRA	BUSY	BTF	ADSL	M/SL	SB
Read Only							

Bit 7 = EVF *Event flag.*

This bit is set by hardware as soon as an event occurs. It is cleared by software reading SR2 register in case of error event or as described in [Figure 69](#). It is also cleared by hardware when the interface is disabled (PE=0).

0: No event

1: One of the following events has occurred:

- BTF=1 (Byte received or transmitted)
- ADSL=1 (Address matched in Slave mode while ACK=1)
- SB=1 (Start condition generated in Master mode)
- AF=1 (No acknowledge received after byte transmission)
- STOPF=1 (Stop condition detected in Slave mode)
- ARLO=1 (Arbitration lost in Master mode)
- BERR=1 (Bus error, misplaced Start or Stop condition detected)
- ADD10=1 (Master has sent header byte)
- Address byte successfully transmitted in Master mode.

Bit 6 = ADD10 *10-bit addressing in Master mode.*

This bit is set by hardware when the master has sent the first byte in 10-bit address mode. It is cleared by software reading SR2 register followed by a write in the DR register of the second address byte. It is also cleared by hardware when the peripheral is disabled (PE=0).

0: No ADD10 event occurred.

1: Master has sent first address byte (header)

Bit 5 = TRA *Transmitter/Receiver.*

When BTF is set, TRA=1 if a data byte has been transmitted. It is cleared automatically when BTF is cleared. It is also cleared by hardware after detection of Stop condition (STOPF=1), loss of bus arbitration (ARLO=1) or when the interface is disabled (PE=0).

0: Data byte received (if BTF=1)

1: Data byte transmitted

Bit 4 = BUSY *Bus busy.*

This bit is set by hardware on detection of a Start condition and cleared by hardware on detection of a Stop condition. It indicates a communication in progress on the bus. The BUSY flag of the I2CSR1 register is cleared if a Bus Error occurs.

0: No communication on the bus

1: Communication ongoing on the bus

Bit 3 = BTF *Byte transfer finished.*

This bit is set by hardware as soon as a byte is correctly received or transmitted with interrupt generation if ITE=1. It is cleared by software reading SR1 register followed by a read or write of DR register. It is also cleared by hardware when the interface is disabled (PE=0).

- Following a byte transmission, this bit is set after reception of the acknowledge clock pulse. In case an address byte is sent, this bit is set only after the EV6 event (See

Figure 69). BTF is cleared by reading SR1 register followed by writing the next byte in DR register.

- Following a byte reception, this bit is set after transmission of the acknowledge clock pulse if ACK=1. BTF is cleared by reading SR1 register followed by reading the byte from DR register.

The SCL line is held low while BTF=1.

- 0: Byte transfer not done
- 1: Byte transfer succeeded

Bit 2 = **ADSL** Address matched (Slave mode).

This bit is set by hardware as soon as the received slave address matched with the OAR register content or a general call is recognized. An interrupt is generated if ITE=1. It is cleared by software reading SR1 register or by hardware when the interface is disabled (PE=0).

The SCL line is held low while ADSL=1.

- 0: Address mismatched or not received
- 1: Received address matched

Bit 1 = **M/SL** Master/Slave.

This bit is set by hardware as soon as the interface is in Master mode (writing START=1). It is cleared by hardware after detecting a Stop condition on the bus or a loss of arbitration (ARLO=1). It is also cleared when the interface is disabled (PE=0).

- 0: Slave mode
- 1: Master mode

Bit 0 = **SB** Start bit (Master mode).

This bit is set by hardware as soon as the Start condition is generated (following a write START=1). An interrupt is generated if ITE=1. It is cleared by software reading SR1 register followed by writing the address byte in DR register. It is also cleared by hardware when the interface is disabled (PE=0).

- 0: No Start condition
- 1: Start condition generated

I²C status register 2 (SR2)

Reset value: 0000 0000 (00h)

7							0
0	0	0	AF	STOPF	ARLO	BERR	GCAL
Read Only							

Bit 7:5 = Reserved.

Forced to 0 by hardware.

Bit 4 = AF Acknowledge failure.

This bit is set by hardware when no acknowledge is returned. An interrupt is generated if ITE=1. It is cleared by software reading SR2 register or by hardware when the interface is disabled (PE=0).

The SCL line is not held low while AF=1 but by other flags (SB or BTF) that are set at the same time.

0: No acknowledge failure
1: Acknowledge failure

Bit 3 = STOPF Stop detection (Slave mode).

This bit is set by hardware when a Stop condition is detected on the bus after an acknowledge (if ACK=1). An interrupt is generated if ITE=1. It is cleared by software reading SR2 register or by hardware when the interface is disabled (PE=0).

The SCL line is not held low while STOPF=1.

0: No Stop condition detected
1: Stop condition detected

Bit 2 = ARLO Arbitration lost.

This bit is set by hardware when the interface loses the arbitration of the bus to another master. An interrupt is generated if ITE=1. It is cleared by software reading SR2 register or by hardware when the interface is disabled (PE=0).

After an ARLO event the interface switches back automatically to Slave mode (M/SL=0).

The SCL line is not held low while ARLO=1.

0: No arbitration lost detected
1: Arbitration lost detected

Note: In a Multimaster environment, when the interface is configured in Master Receive mode it does not perform arbitration during the reception of the Acknowledge Bit. A mishandling of the ARLO bit from the I2CSR2 register may occur when a second master simultaneously requests the same data from the same slave, and the I²C master does not acknowledge the data. The ARLO bit is then left at 0 instead of being set.

Bit 1 = BERR Bus error.

This bit is set by hardware when the interface detects a misplaced Start or Stop condition. An interrupt is generated if ITE=1. It is cleared by software reading SR2 register or by hardware when the interface is disabled (PE=0).

The SCL line is not held low while BERR=1.

0: No misplaced Start or Stop condition
1: Misplaced Start or Stop condition

Note: If a Bus Error occurs, a Stop or a repeated Start condition should be generated by the Master to re-synchronize communication, get the transmission acknowledged and the bus released for further communication

Bit 0 = GCAL General Call (Slave mode).

This bit is set by hardware when a general call address is detected on the bus while ENGC=1. It is cleared by hardware detecting a Stop condition (STOPF=1) or when the interface is disabled (PE=0).

0: No general call address detected on the bus
1: General call address detected on the bus

I²C clock control register (CCR)

Reset value: 0000 0000 (00h)

7							0
FM/SM	CC6	CC5	CC4	CC3	CC2	CC1	CC0
Read / Write							

Bit 7 = **FM/SM** *Fast/Standard I²C mode.*

This bit is set and cleared by software. It is not cleared when the interface is disabled (PE=0).

0: Standard I²C mode1: Fast I²C modeBit 6:0 = **CC[6:0]** *7-bit clock divider.*

These bits select the speed of the bus (F_{SCL}) depending on the I²C mode. They are not cleared when the interface is disabled (PE=0).

Refer to [Section 13: Electrical characteristics](#) for the table of values.

Note: The programmed f_{SCL} assumes no load on SCL and SDA lines.

I²C data register (DR)

Reset value: 0000 0000 (00h)

7							0
D7	D6	D5	D4	D3	D2	D1	D0
Read / Write							

Bits 7:0 = **D[7:0]** 8-bit Data Register.

These bits contain the byte to be received or transmitted on the bus.

- Transmitter mode: byte transmission start automatically when the software writes in the DR register.
- Receiver mode: the first data byte is received automatically in the DR register using the least significant bit of the address.
Then, the following data bytes are received one by one after reading the DR register.

I²C own address register (OAR1)

Reset value: 0000 0000 (00h)

7							0
ADD7	ADD6	ADD5	ADD4	ADD3	ADD2	ADD1	ADD0
Read / Write							

7-bit addressing modeBits 7:1 = **ADD[7:1]** Interface address.These bits define the I²C bus address of the interface. They are not cleared when the interface is disabled (PE=0).Bit 0 = **ADD0** Address direction bit.

This bit is don't care, the interface acknowledges either 0 or 1. It is not cleared when the interface is disabled (PE=0).

*Note: Address 01h is always ignored.***10-bit addressing mode**Bit 7:0 = **ADD[7:0]** Interface address.These are the least significant bits of the I²C bus address of the interface. They are not cleared when the interface is disabled (PE=0).

I²C own address register (OAR2)

Reset value: 0100 0000 (40h)

7	0	0	0	0	ADD9	ADD8	0
FR1	FR0	0	0	0	ADD9	ADD8	0
Read / Write							

Bit 7:6 = **FR[1:0]** *Frequency bits.*

These bits are set by software only when the interface is disabled (PE=0). To configure the interface to I²C specified delays select the value corresponding to the microcontroller frequency f_{CPU} .

Table 66. FR[1:0] configuration

f_{CPU}	FR1	FR0
< 6 MHz	0	0
6 to 8 MHz	0	1

Bits 5:3 = Reserved

Bits 2:1 = **ADD[9:8]** *Interface address.*

These are the most significant bits of the I²C bus address of the interface (10-bit mode only). They are not cleared when the interface is disabled (PE=0).

Bit 0 = Reserved.

Table 67. I²C register map and reset values

Address (Hex.)	Register label	7	6	5	4	3	2	1	0
0058h	I2CCR Reset value	0	0	PE 0	ENGC 0	START 0	ACK 0	STOP 0	ITE 0
0059h	I2CSR1 Reset value	EVF 0	ADD10 0	TRA 0	BUSY 0	BTF 0	ADSL 0	M/SL 0	SB 0
005Ah	I2CSR2 Reset value	0	0	0	AF 0	STOPF 0	ARLO 0	BERR 0	GCAL 0
005Bh	I2CCCR Reset value	FM/SM 0	CC6 0	CC5 0	CC4 0	CC3 0	CC2 0	CC1 0	CC0 0
005Ch	I2COAR1 Reset value	ADD7 0	ADD6 0	ADD5 0	ADD4 0	ADD3 0	ADD2 0	ADD1 0	ADD0 0
005Dh	I2COAR2 Reset value	FR1 0	FR0 1	0	0	0	ADD9 0	ADD8 0	0
005Eh	I2CDR Reset value	MSB 0	0	0	0	0	0	0	LSB 0

11.7 I2C triple slave interface with DMA (I2C3S)

11.7.1 Introduction

The I²C3S interface provides three I2C slave functions, supporting both standard (up to 100 kHz) and fast I²C mode (100 to 400 kHz). Special features are provided for:

- Full-speed emulation of standard I²C E²PROMs
- Receiving commands to perform user-defined operations such as IAP

11.7.2 Main features

- Three user configurable independent slave addresses can be individually enabled
- 2x 256 bytes and 1x 128 bytes buffers with fixed addresses in RAM
- 7-bit addressing
- DMA transfer to/from I²C bus and RAM
- Standard (transfers 256 bytes at up to 100 kHz)
- Fast mode (transfers 256 bytes at up to 400 kHz)
- Transfer error detection and handling
- 3 interrupt flags per address for maximum flexibility
- Two interrupt request lines (one for Slaves 1 and 2, the other for Slave 3)
- Full emulation of standard I²C EEPROMs:
 - Supports 5 read/write commands and combined format
 - No I²C clock stretching
 - Programmable page size (8/16 bytes) or full buffer
 - Configurable write protection
- Data integrity and byte-pair coherency when reading 16-bit words from I²C bus

Figure 71. I²C3S interface block diagram

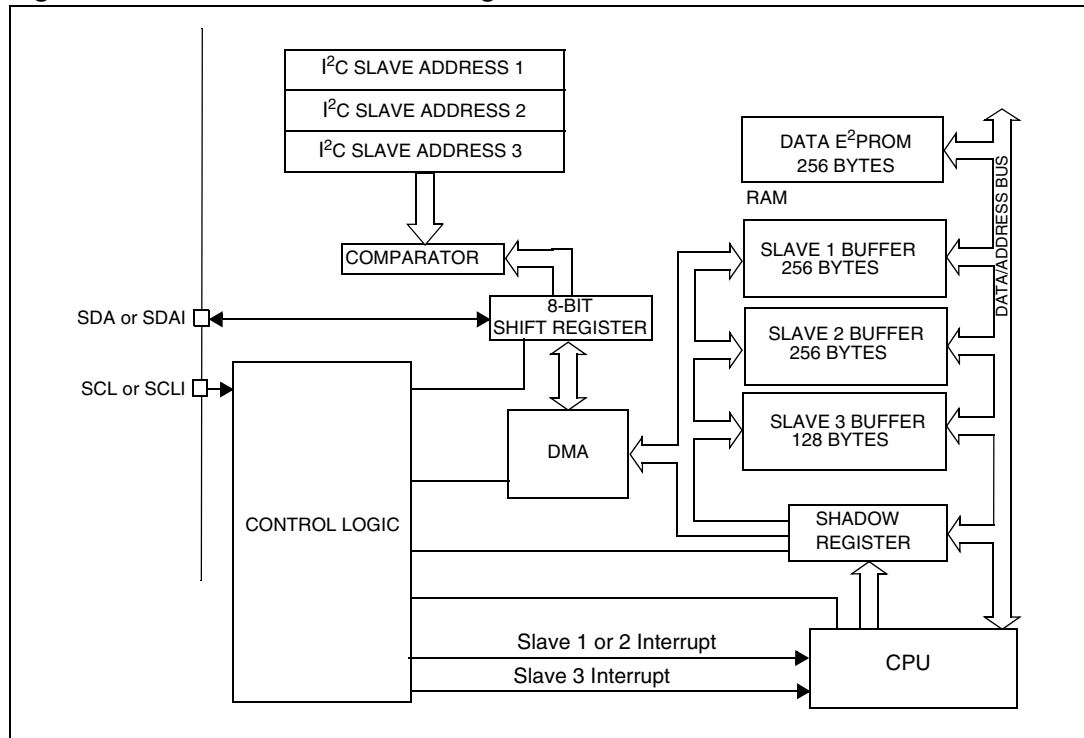

11.7.3 General description

In addition to receiving and transmitting data, I2C3S converts it from serial to parallel format and vice versa. The interrupts are enabled or disabled by software. The I2C3S is connected to the I²C bus by a data pin (SDA) and by a clock pin (SCL). It can be connected both with a standard I²C bus and a Fast I²C bus. The interface operates only in Slave mode as transmitter/receiver.

In order to fully emulate standard I²C EEPROM devices with highest transfer speed, the peripheral prevents I²C clock signal stretching and performs data transfer between the shift register and the RAM buffers using DMA.

Communication flow

A serial data transfer normally begins with a start condition and ends with a stop condition. Both start and stop conditions are generated by an external master. Refer to [Figure 67](#) for the standard protocol. The I2C3S is not a master and is not capable of generating a start/stop condition on the SDA line. The I2C3S is capable of recognizing 3 slave addresses which are user programmable. The three I²C slave addresses can be individually enabled/disabled by software.

Since the I2C3S interface always acts as a slave, it does not generate a clock. Data and addresses are transferred as 8-bit bytes, MSB first. The first byte following the start condition contains the slave address. A 9th clock pulse follows the 8 clock cycles of a byte transfer, during which the receiver must send an acknowledge bit to the transmitter.

SDA/SCL line control

- When the I2C3S interface is enabled, the SDA and SCL ports must be configured as floating inputs. In this case, the value of the external pull-up resistor used depends on the application.
- When the I2C3S interface is disabled, the SDA and SCL ports revert to being standard I/O port pins.

Figure 72. I²C bus protocol

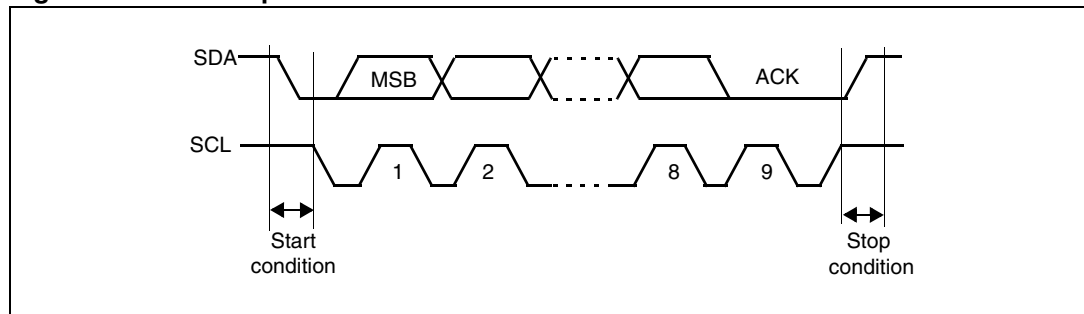

11.7.4 Functional description

The three slave addresses 1, 2 and 3 can be used as general purpose I²C slaves. They also support all features of standard I²C EEPROMs like the ST M24Cxx family and are able to fully emulate them.

Slaves 1 and 2 are mapped on the same interrupt vector. Slave 3 has a separate interrupt vector with higher priority.

The three slave addresses are defined by writing the 7 MSBs of the address in the I2C3SSAR1, I2C3SSAR2 and I2C3SSAR3 registers. The slaves are enabled by setting the enable bits in the same registers.

Each slave has its own RAM buffer at a fixed location in the ST7 RAM area.

- Slaves 1 and 2 have 256-byte buffers which can be individually protected from I²C master write accesses.
- Slave 3 has a 128-byte RAM buffer without write protection feature.

All three slaves have individual read flags (RF) and write flags (WF) with maskable interrupts. These flags are set when the I²C master has completed a read or write operation.

Paged operation

To allow emulation of Standard I²C EEPROM devices, pages can be defined in the RAM buffer. The pages are configured using the PL[1:0] bits in the I2C3SCR1 register. 8/16-Byte page length has to be selected depending on the EEPROM device to emulate. The Full Page option is to be used when no paging of the RAM buffer is required. The configuration is common to the 3 slave addresses. The Full Page configuration corresponds to 256 bytes for address 1 and 2 and to 128 bytes for address 3.

Paging affects the handling of rollover when write operations are performed. In case the bottom of the page is reached, the write continues from the first address of the same page. Page length does not affect read operations: rollover is done on the whole RAM buffer whatever the configured page length.

The Byte count register is reset when it reaches 256 bytes, whatever the page length, for all slave addresses, including slave 3.

DMA

The I²C slaves use a DMA controller to write/read data to/from their RAM buffer.

A DMA request is issued to the DMA controller on reception of a byte or just before transmission of a byte.

When a byte is written by DMA in RAM, the CPU is stalled for max. 2 cycles. When several bytes are transferred from the I2C bus to RAM, the DMA releases between each byte and the CPU resumes processing until the DMA writes the next byte.

RAM buffer write protection

By setting the WP1/WP2 bits in the I2C3SCR2 register, it is possible to protect the RAM buffer of Slaves 1/2 respectively against write access from the master.

If a write operation is attempted, the slave address is acknowledged, the current address register is overwritten, data is also acknowledged but it is not written to the RAM. Both the current address and byte count registers are incremented as in normal operation.

In case of write access to a write protected address, no interrupt is generated and the BusyW bit in the I2C3SCR2 register is not set.

Only write operations are disabled/enabled. Read operations are not affected.

Byte-pair coherency for I²C read operations

Byte-pair coherency allows the I²C master to read a 16-bit word and ensures that it is not corrupted by a simultaneous CPU update. Two mechanisms are implemented, covering the two possible cases:

1. CPU updates a word in RAM after the first byte has been transferred to the I2C shift register from RAM. In this case, the first byte read from RAM would be the MSB of the old word and 2nd byte would be the LSB of the new word.
To prevent this corruption, the I2C3S uses DMA to systematically read a 2-byte word when it receives a read command from the I²C master. The MSB of the word should be at address 2n. Using DMA, the MSB is moved from RAM address 2n to the I2C shift register and the LSB from RAM address 2n+1 moved to a shadow register in the I2C3S peripheral. The CPU is stalled for a maximum of 2 cycles during word transfer.
In case only one byte is read, the unused content of the shadow register will be automatically overwritten when a new read operation is performed.
In case a second byte is read in the same I²C message (no Stop or Restart condition), the content of the shadow register is transferred to the shift register and transmitted to the master.
This process continues until a Stop or Restart condition occurs.
2. I2C3S attempts to read a word while the CPU is updating the RAM buffer. To prevent data corruption, the CPU must switch operation to Word mode prior to updating a word in the RAM buffer. Word mode is enabled by software using the B/W bit in the I2C3SCR2 register. In Word mode, when the CPU writes the MSB of a word to address 2n, it is stored in a shadow register rather than being actually written in RAM. When the CPU writes the second byte (the LSB) at address 2n+1, it is directly written in RAM. The next cycle after the write to address 2n+1, the MSB is automatically written from the shadow register to RAM address 2n. DMA is disabled for a 1 cycle while the CPU is writing a word.

Word mode is disabled by hardware after the word update is performed. It must be enabled before each word update by CPU.

Use the following procedure when the ST7 writes a word in RAM:

1. Disable interrupts
2. Enable Word mode by setting the B/W and BusyW bits in the I2C3SCR2 register. BusyW bit is set to 1 when modifying any bits in Control Register 2. Writing a 1 to this bit does not actually modify BusyW but prevents accidental clearing of the bit.
3. Write Byte 1 in an even address in RAM. The byte is not actually written in RAM but in a shadow register. This address must be within the I2C RAM buffer of slave addresses 1, 2 or 3.
4. Write Byte 2 in the next higher address in RAM. This byte is actually written in RAM. During the next cycle, the shadow register content is written in the lower address. The DMA request is disabled during this cycle.
5. Byte mode resumes automatically after writing byte 2 and DMA is re-enabled.
6. Enable interrupts

Note: Word mode does not guarantee byte-pair coherency of words WRITTEN by the I2C master in RAM and read by the ST7. In this case, byte pair coherency must be handled by software.

Figure 73. 16-bit word write operation flowchart

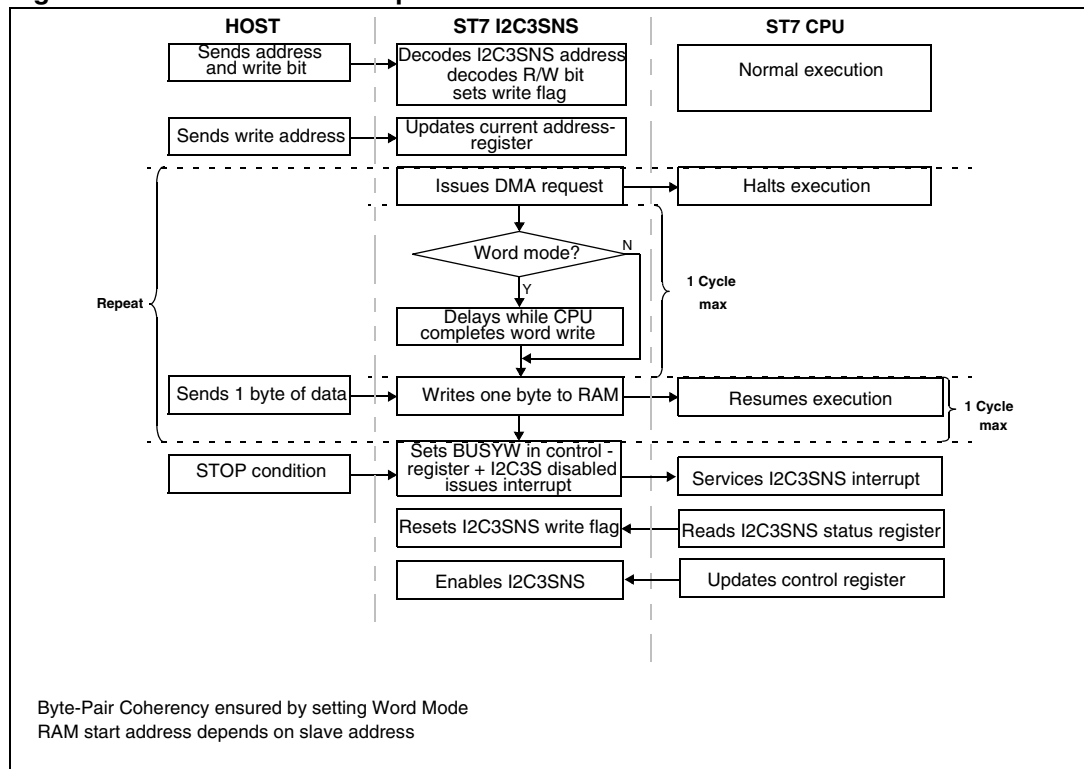
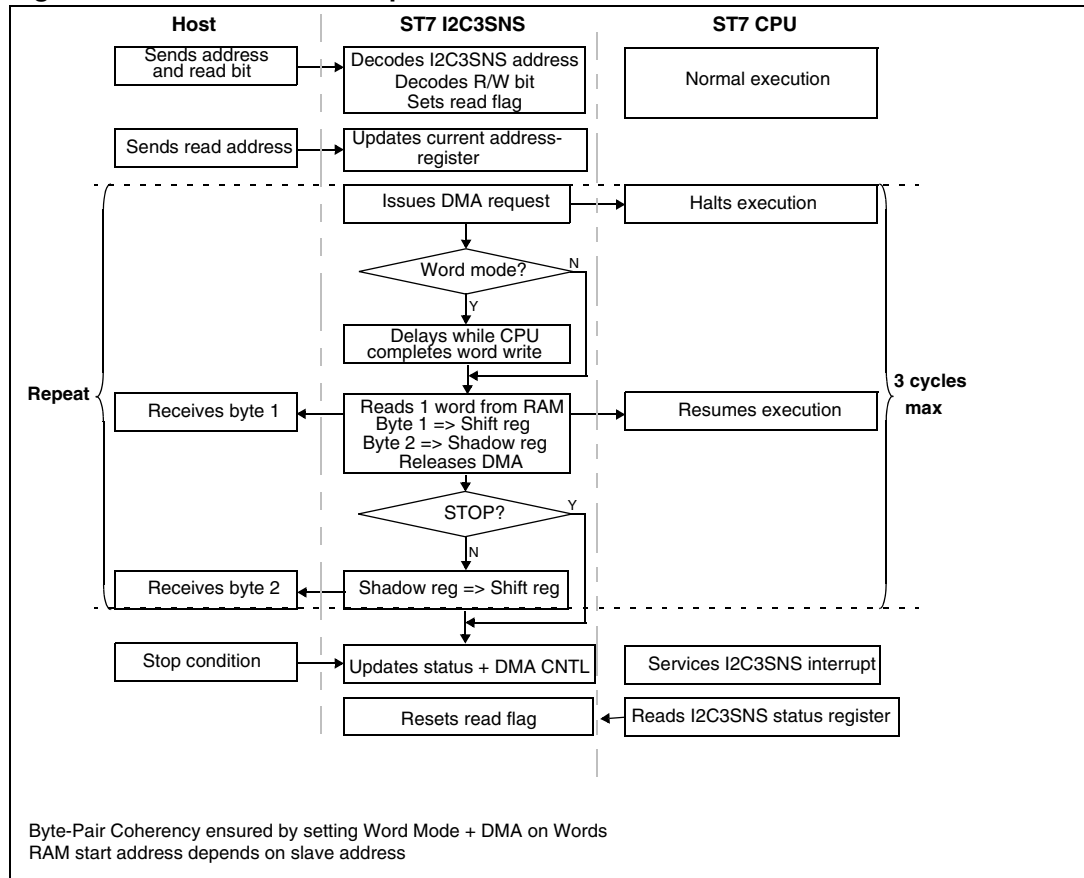

Figure 74. 16-bit word read operation flowchart



Application note

Taking full advantage of its higher interrupt priority Slave 3 can be used to allow the addressing master to send data bytes as commands to the ST7. These commands can be decoded by the ST7 software to perform various operations such as programming the Data E2PROM via IAP (In-Application Programming).

Slave 3 writes the command byte and other data in the RAM and generates an interrupt. The ST7 then decodes the command and processes the data as decoded from the command byte. The ST7 also writes a status byte in the RAM which the addressing master can poll.

11.7.5 Address handling

As soon as a start condition is detected, the address is received from the SDA line and sent to the shift register. Then it is compared with the three addresses of the interface to decode which slave of the interface is being addressed.

Address not matched: the interface ignores it and waits for another Start condition.

Address matched: the interface generates in sequence the following:

- An Acknowledge pulse
- Depending on the LSB of the slave address sent by the master, slaves enter transmitter or receiver mode.
- Send an interrupt to the CPU after completion of the read/write operation after detecting the Stop/ Restart condition on the SDA line.

Note: The Status Register has to be read to clear the event flag associated with the interrupt. An interrupt will be generated only if the interrupt enable bit is set in the Control Register. Slaves 1 and 2 have a common interrupt and the Slave 3 has a separate interrupt. At the end of write operation, I2C3S is temporarily disabled by hardware by setting BusyW bit in CR2. The byte count register, status register and current address register should be saved before resetting BusyW bit.

Slave reception (write operations)

Byte Write: The Slave address is followed by an 8-bit byte address. Upon receipt of this address, an acknowledge is generated, the address is moved into the current address register and the 8-bit data is clocked in. Once the data is shifted in, a DMA request is generated and the data is written in the RAM. The addressing device will terminate the write sequence with a stop condition. Refer to [Figure 76](#).

Page Write: A page write is initiated in a similar way to a byte write, but the addressing device does not send a stop condition after the first data byte. The page length is programmed using bits 7:6 (PL[1:0]) in the Control Register1.

The current address register value is incremented by one every time a byte is written. When this address reaches the page boundary, the next byte will be written at the beginning of the same page. Refer to [Figure 77](#).

Slave transmission (Read operations)

Current address read: The current address register maintains the last address accessed during the last read or write operation incremented by one.

During this operation the I2C slave reads the data pointed by the current address register. Refer to [Figure 78](#).

Random read: Random read requires a dummy byte write sequence to load in the byte address. The addressing device then generates restart condition and resends the device address similar to current address read with the read/write bit high. Refer to [Figure 79](#). Some types of I2C masters perform a dummy write with a stop condition and then a current address read.

In either case, the slave generates a DMA request, sends an acknowledge and serially clocks out the data.

When the memory address limit is reached, the current address will roll over and the random read will continue till the addressing master sends a stop condition.

Sequential read: Sequential reads are initiated by either a current address read or a random address read. After the addressing master receives the data byte, it responds with an acknowledge. As long as the slave receives an acknowledge, it continues to increment the current address register and clock out sequential data bytes.

When the memory address limit is reached the current address will roll over and the sequential read will continue till the addressing master sends a stop condition. Refer to [Figure 81](#).

Combined format

If a master wants to continue communication either with another slave or by changing the direction of transfer then the master would generate a restart and provide a different slave address or the same slave address with the R/W bit reversed. Refer to [Figure 82](#).

Rollover handling

The RAM buffer of each slave is divided into pages whose length is defined according to PL1:0 bits in I2C3SCR1. Rollover takes place in these pages as described below.

In the case of Page Write, if the number of data bytes transmitted is more than the page length, the current address will roll over to the first byte of the current page and the previous data will be overwritten. This page size is configured using PL[1:0] bit in the I2C3SCR1 register.

In case of Sequential Read, if the current address register value reaches the memory address limit the address will roll over to the first address of the reserved area for the respective slave.

There is no status flag to indicate the roll over.

Note: The reserved areas for slaves 1 and 2 have a limit of 256 bytes. The area for slave 3 is 128 bytes. The MSB of the address is hardwired, the addressing master therefore needs to send only an 8 bit address.

The page boundaries are defined based on the page size configuration using PL[1:0] bit in the I2C3SCR1 register. If an 8-byte page size is selected, the upper 5 bits of the RAM address are fixed and the lower 3 bits are incremented. For example, if the page write starts at register address 0x0C, the write will follow the sequence 0x0C, 0x0D, 0x0E, 0x0F, 0x08, 0x09, 0x0A, 0x0B. If a 16-byte page size is selected, the upper 4 bits of the RAM address are fixed and the lower 4 bits are incremented. For example, if the page write starts at register address 0x0C, the write will follow the sequence 0x0C, 0x0D, 0x0E, 0x0F, 0x00, 0x01, etc.

Error conditions

- **BERR:** Detection of a Stop or a Start condition during a byte transfer. In this case, the BERR bit is set by hardware with an interrupt if ITER is set. During a stop condition, the interface discards the data, releases the lines and waits for another Start condition. However, a BERR on a Start condition will result in the interface discarding the data and waiting for the next slave address on the bus.
- **NACK:** Detection of a non-acknowledge bit not followed by a Stop condition. In this case, NACK bit is set by hardware with an interrupt if ITER is set.

Figure 75. Transfer sequencing

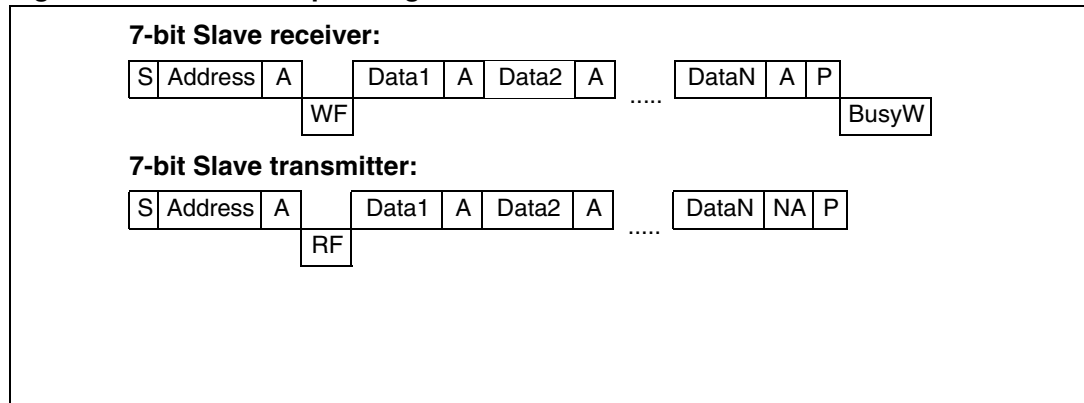

Legend: S = Start, P = Stop, A = Acknowledge, NA = Non-acknowledge, WF = WF event, WFx bit is set (with interrupt if ITWEx=1, after Stop or Restart conditions), cleared by reading the I2C3SSR register while no communication is ongoing.

RF = RF event, RFx is set (with interrupt if ITREx=1, after Stop or Restart conditions), cleared by reading the I2C3SSR register while no communication is ongoing.

BusyW = BusyW flag in the I2C3CR2 register set, cleared by software writing 0.

Note: The I2C3S supports a repeated start (S_r) in place of a stop condition (P).

Figure 76. Byte write

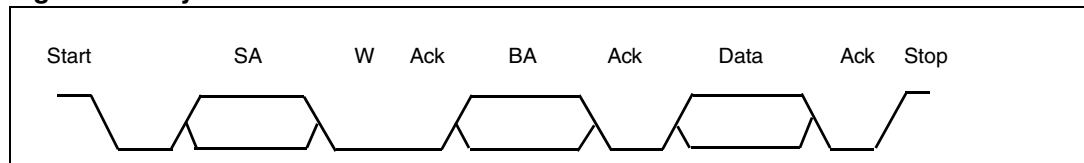

Figure 77. Page write

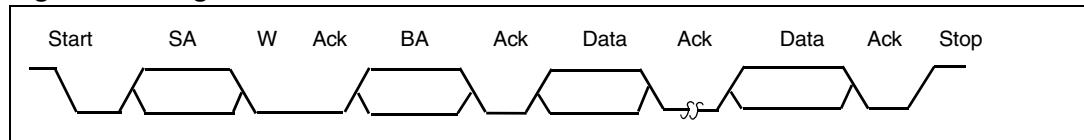

Figure 78. Current address read

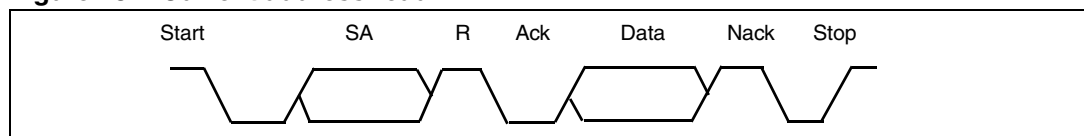

Figure 79. Random read (dummy write + restart + current address read)

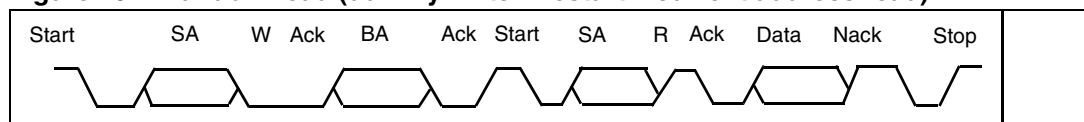

Figure 80. Random read (dummy write + stop + start + current address read)

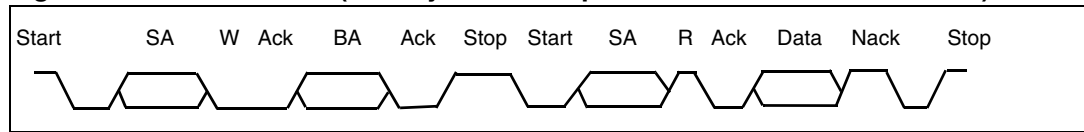

Figure 81. Sequential read

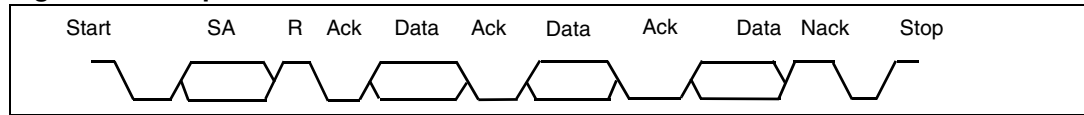
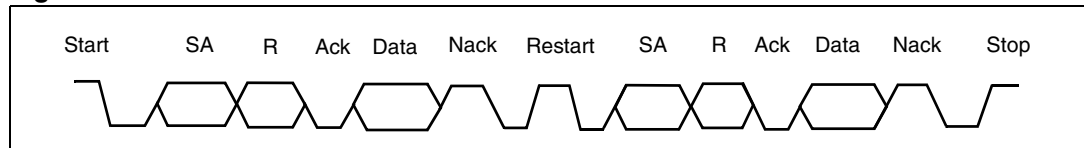

Figure 82. Combined format for read



Legend: SA - Slave Address, BA - Byte Address, W: Write, R: Read

11.7.6 Low-power modes

Table 68. Mode description

Mode	Description
Wait	No effect on I ² C interface. I2C interrupts causes the device to exit from Wait mode.
Halt	I ² C registers are frozen. In Halt mode, the I ² C interface is inactive and does not acknowledge data on the bus. The I ² C interface resumes operation when the MCU is woken up by an interrupt with "exit from Halt mode" capability.
Active-halt	I ² C registers are frozen. In Active halt mode, the I ² C interface is inactive and does not acknowledge data on the bus. The I ² C interface resumes operation when the MCU is woken up by an interrupt with "exit from Active-halt mode" capability.

11.7.7 Interrupt generation

Figure 83. Event flags and interrupt generation

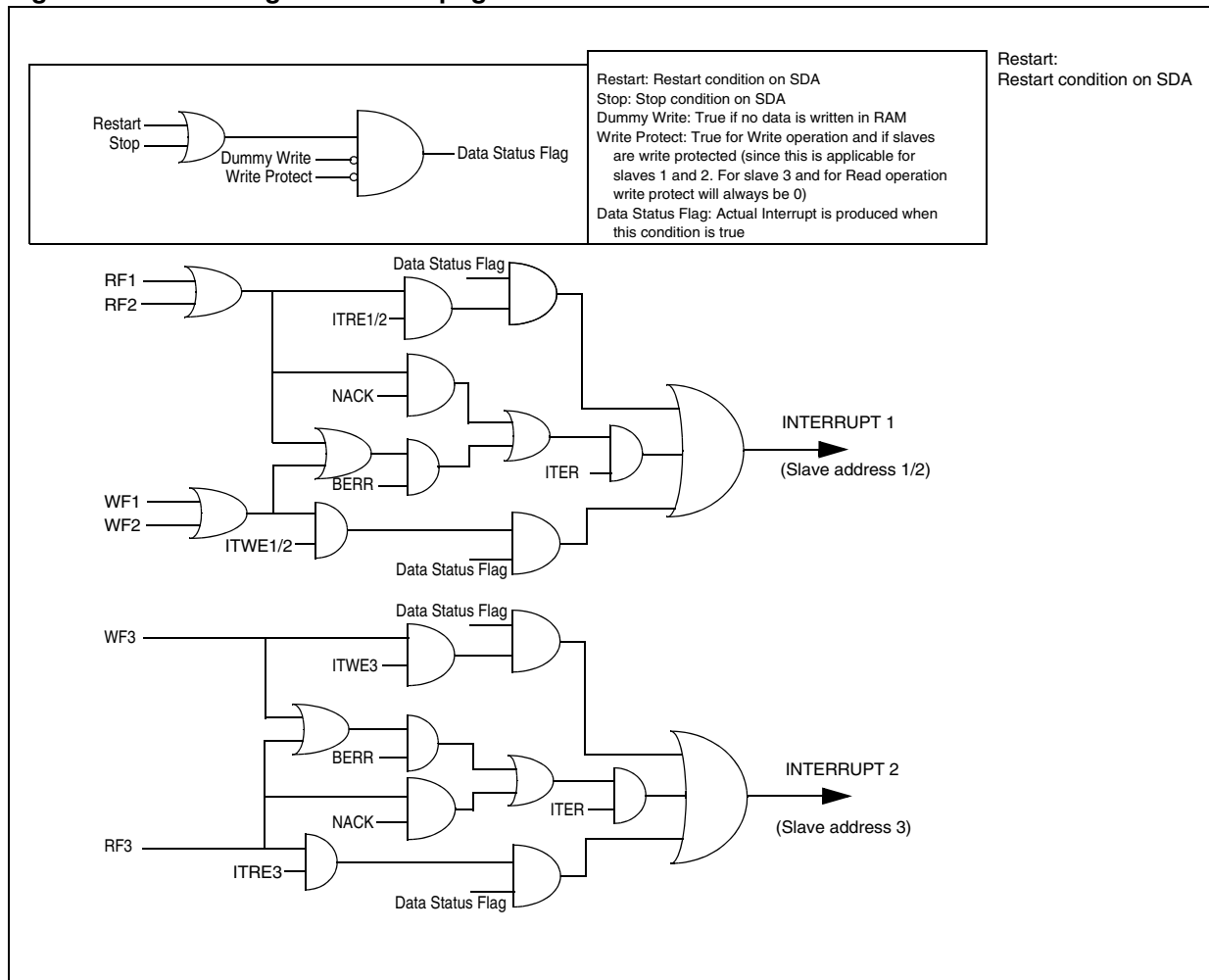

Note: Read/Write interrupts are generated only after stop or restart conditions. Figure 83 shows the conditions for the generation of the two interrupts.

Table 69. Interrupt events

Interrupt event	Flag	Enable control bit	Exit from wait	Exit from halt
Interrupt on write to Slave 1	WF1	ITWE1	Yes	No
Interrupt on write to Slave 2	WF2	ITWE1	Yes	No
Interrupt on write to Slave 3	WF3	ITWE2	Yes	No
Interrupt on Read from Slave 1, Slave 2 or Slave 3.	RF1- RF3	ITREx	Yes	No
Errors	BERR, NACK	ITER	Yes	No

11.7.8 Register description

I²C 3S control register 1 (I2C3SCR1)

Reset value: 0000 0000 (00h)

7	0
PL1	PL0
0	0
ITER	ITRE3
ITRE1/2	ITWE3
ITWE1/2	ITWE1/2
Read / Write	

Bits 7:6 = **PL1:0** *Page length configuration*

This bit is set and cleared by software. It is also cleared by hardware when the interface is disabled (PE=0).

Table 70. PL configuration

PL1	PL0	Page length
0	0	8
0	1	16
1	0	Full Page (256 bytes for slave 1 & 2, 128 bytes for slave 3)
1	1	NA

Bit 5 = Reserved, must be kept at 0.

Bit 4 = **ITER** *BERR / NACK Interrupt enable*

This bit is set and cleared by software. It is also cleared by hardware when the interface is disabled (PE=0).

- 0: BERR / NACK interrupt disabled
- 1: BERR / NACK interrupt enabled

Note: In case of error, if ITER is enabled either interrupt 1 or 2 is generated depending on which slave flags the error (see [Figure 83](#)).

Bit 3= **ITRE3** *Interrupt enable on read from Slave 3*

This bit is set and cleared by software. It is also cleared by hardware when the interface is disabled (PE =0).

- 0: Interrupt on Read from Slave 3 disabled
- 1: Interrupt on Read from Slave 3 enabled

Bit 2 = **ITRE1/2** *Interrupt enable on read from Slave 1 or 2*

This bit is set and cleared by software. It is also cleared by hardware when the interface is disabled.

- (PE =0)
- 0: Interrupt on Read from Slave 1 or 2 disabled
- 1: Interrupt on Read from Slave 1 or 2 enabled

Bit 1 = **ITWE3** *Interrupt enable on write to Slave 3*

This bit is set and cleared by software. It is also cleared by hardware when the interface is disabled.

- 0: Interrupt after write to Slave 3 disabled
- 1: Interrupt after write to Slave 3 enabled

Bit 0 = **ITWE1/2** *Interrupt enable on write to Slave 1 or 2*

This bit is set and cleared by software. It is also cleared by hardware when the interface is disabled software. It is also cleared by hardware when the interface is disabled.

- 0: Interrupt after write to Slave 1 or 2 disabled
- 1: Interrupt after write to Slave 1 or 2 enabled

I2C control register 2 (I2C3SCR2)

Reset value: 0000 0000 (00h)

7				WP2	WP1	PE	BusyW	0
0	0	0						
Read / Write								

Bits 7:5 = Reserved, must be kept at 0.

Bit 4 = **WP2** *Write Protect enable for Slave 2*

This bit is set and cleared by software. It is also cleared by hardware when the interface is disabled (PE=0)

- 0: Write access to Slave 2 RAM buffer enabled
- 1: Write access to Slave 2 RAM buffer disabled

Bit 3 = **WP1** *Write Protect enable for Slave 1*

This bit is set and cleared by software. It is also cleared by hardware when the interface is disabled (PE=0).

- 0: Write access to Slave 1 RAM buffer enabled
- 1: Write access to Slave 1 RAM buffer disabled

Note: (Applicable for both WP2/ WP1)

Only write operations are disabled/enabled. Read operations are not affected.

If a write operation is attempted, the slave address is acknowledged, the current address register is overwritten, data is also acknowledged but it is not written to the RAM.

Both the current address and byte count registers are incremented as in normal operation.

No interrupt generated if slave is write protected

BusyW will not be set if slave is write protected

Bit 2 = **PE** *Peripheral enable*

This bit is set and cleared by software.

- 0: Peripheral disabled
- 1: Slave capability enabled

Note: To enable the I²C interface, write the CR register TWICE with PE=1, as the first write only activates the interface (only PE is set).

Bit 1 = **BusyW** *Busy on Write to RAM Buffer*

This bit is set by hardware when a Stop/ Restart is detected after a write operation. The I2C3S peripheral is temporarily disabled till this bit is reset. This bit is cleared by software. If this bit is not cleared before the next slave address reception, further communication will be non-acknowledged. This bit is set to 1 when modifying any bits in Control Register 2. Writing a 1 to this bit does not actually modify BusyW but prevents accidentally clearing of the bit.

- 0: No BusyW event occurred
- 1: A Stop/ Restart is detected after a write operation

Bit 0 = **B/W** *Byte / Word Mode*

This control bit must be set by software before a word is updated in the RAM buffer and cleared by hardware after completion of the word update. In Word mode the CPU cannot be interrupted when it is modifying the LSB byte and MSB byte of the word. This mode is to ensure the coherency of data stored as words.

- 0: Byte mode
- 1: Word mode

Note: When the word mode is enabled, all interrupts should be masked while the word is being written in RAM.

I²C3S status register (I2C3SSR)

Reset value: 0000 0000 (00h)

7									0
NACK	BERR	WF3	WF2	WF1	RF3	RF2	RF1		
Read Only									

Bit 7= **NACK** *Non Acknowledge not followed by Stop*

This bit is set by hardware when a non acknowledge returned by the master is not followed by a Stop or Restart condition. It is cleared by software reading the SR register or by hardware when the interface is disabled (PE=0).

- 0: No NACK error occurred
- 1: Non Acknowledge not followed by Stop

Bit 6 = **BERR** *Bus error*

This bit is set by hardware when the interface detects a misplaced Start or Stop condition. It is cleared by software reading SR register or by hardware when the interface is disabled (PE=0).

The SCL line is not held low while BERR=1.

- 0: No misplaced Start or Stop condition
- 1: Misplaced Start or Stop condition

Bit 5 = **WF3** *Write operation to Slave 3*

This bit is set by hardware on reception of the direction bit in the I²C address byte for Slave 3. This bit is cleared when the status register is read and there is no communication ongoing or when the peripheral is disabled (PE = 0)

- 0: No write operation to Slave 3
- 1: Write operation performed to Slave 3

Bit 4 = WF2 Write operation to Slave 2

This bit is set by hardware on reception of the direction bit in the I²C address byte for Slave 2. This bit is cleared when the status register is read and there is no communication ongoing, or when the peripheral is disabled (PE = 0)

- 0: No write operation to Slave 2
- 1: Write operation performed to Slave 2

Bit 3 = WF1 Write operation to Slave 1

This bit is set by hardware on reception of the direction bit in the I²C address byte for Slave 1. This bit is cleared by software when the status register is read and there is no communication ongoing, or by hardware when the peripheral is disabled (PE = 0).

- 0: No write operation to Slave 1
- 1: Write operation performed to Slave 1

Bit 2 = RF3 Read operation from Slave 3

This bit is set by hardware on reception of the direction bit in the I²C address byte for Slave 3. It is cleared by software reading the SR register when there is no communication ongoing. It is also cleared by hardware when the interface is disabled (PE=0).

- 0: No read operation from Slave 3
- 1: Read operation performed from Slave 3

Bit 1= RF2 Read operation from Slave 2

This bit is set by hardware on reception of the direction bit in the I²C address byte for Slave 2. It is cleared by software reading the SR register when there is no communication ongoing. It is also cleared by hardware when the interface is disabled (PE=0).

- 0: No read operation from Slave 2
- 1: Read operation performed from Slave 2

Bit 0= RF1 Read operation from Slave 1

This bit is set by hardware on reception of the direction bit in the I²C address byte for Slave 1. It is cleared by software reading SR register when there is no communication ongoing. It is also cleared by hardware when the interface is disabled (PE=0).

- 0: No read operation from Slave 1
- 1: Read operation performed from Slave 1

I²C byte count register (I2C3SBCR)

Reset value: 0000 0000 (00h)

7							0
NB7	NB6	NB5	NB4	NB3	NB2	NB1	NB0
Read only							

Bits 7:0 = NB [7:0] Byte Count Register

This register keeps a count of the number of bytes received or transmitted through any of the three addresses. This byte count is reset after reception by a slave address of a new transfer and is incremented after each byte is transferred. This register is not limited by the full page length. It is also cleared by hardware when the interface is disabled (PE =0).

I2C slave 1 address register (I2C3SSAR1)

Reset value: 0000 0000 (00h)

7							0
ADDR7	ADDR6	ADDR5	ADDR4	ADDR3	ADDR2	ADDR1	EN1
Read / Write							

Bits 7:1 = **ADDR[7:1]** *Address of Slave 1*

This register contains the first 7 bits of Slave 1 address (excluding the LSB) and is user programmable. It is also cleared by hardware when the interface is disabled (PE =0).

Bit 0= **EN1** *Enable bit for Slave Address 1*

This bit is used to enable/disable Slave Address 1. It is also cleared by hardware when the interface is disabled (PE =0).

- 0: Slave Address 1 disabled
- 1: Slave Address 1 enabled

I2C slave 2 address register (I2C3SSAR2)

Reset value: 0000 0000 (00h)

7							0
ADDR7	ADDR6	ADDR5	ADDR4	ADDR3	ADDR2	ADDR1	EN2
Read / Write							

Bits 7:1 = **ADDR[7:1]** *Address of Slave 2.*

This register contains the first 7 bits of Slave 2 address (excluding the LSB) and is user programmable. It is also cleared by hardware when the interface is disabled (PE =0).

Bit 0= **EN2** *Enable bit for Slave Address 2*

This bit is used to enable/disable Slave Address 2. It is also cleared by hardware when the interface is disabled (PE =0).

- 0: Slave Address 2 disabled
- 1: Slave Address 2 enabled

I2C slave 3 address register (I2C3SSAR3)

Reset value: 0000 0000 (00h)

7							0
ADDR7	ADDR6	ADDR5	ADDR4	ADDR3	ADDR2	ADDR1	EN3
Read / Write							

Bit 7:1 = **ADDR[7:1]** *Address of Slave 3*

This register contains the first 7 bits of Slave 3 address (excluding the LSB) and is user programmable. It is also cleared by hardware when the interface is disabled (PE =0).

Bit 0= **EN3** *Enable bit for Slave Address 3*

This bit is used to enable/disable Slave Address 3. It is also cleared by hardware when the interface is disabled (PE =0).

- 0: Slave Address 3 disabled
- 1: Slave Address 3 enabled

I2C slave 1 memory current address register (I2C3SCAR1)

Reset value: 0000 0000 (00h)

7								0
CA7	CA6	CA5	CA4	CA3	CA2	CA1	CA0	
Read only								

Bit 7:0 = **CA[7:0]** *Current address of Slave 1 buffer*

This register contains the 8 bit offset of Slave Address 1 reserved area in RAM. It is also cleared by hardware when the interface is disabled (PE =0).

I2C slave 2 memory current address register (I2C3SCAR2)

Reset value: 0000 0000 (00h)

7								0
CA7	CA6	CA5	CA4	CA3	CA2	CA1	CA0	
Read only								

Bit 7:0 = **CA[7:0]** *Current address of Slave 2 buffer*

This register contains the 8-bit offset of Slave Address 2 reserved area in RAM. It is also cleared by hardware when the interface is disabled (PE =0).

I2C slave 3 memory current address register (I2C3SCAR3)

Reset value: 0000 0000 (00h)

7								0
CA7	CA6	CA5	CA4	CA3	CA2	CA1	CA0	
Read only								

Bit 6:0 = **CA[6:0]** *Current address of Slave 3 buffer*

This register contains the 8-bit offset of slave address 3 reserved area in RAM. It is also cleared by hardware when the interface is disabled (PE =0).

Note: Slave address 3 can store only 128 bytes. For slave address 3, CA7 bit will remain 0. i.e. if the Byte Address sent is 0x80, then the Current Address register will hold the 0x00 value due to an overflow.

Table 71. I²C3S register map

Address (Hex.)	Register name	7	6	5	4	3	2	1	0
0060h	I2C3SCR1	PL1	PL0	0	ITER	ITRE3	ITRE1/2	ITWE3	ITWE1/2
0061h	I2C3SCR2	0	0	0	WP2	WP1	PE	BusyW	B/W
0062h	I2C3SSR	NACK	BERR	WF3	WF2	WF1	RF3	RF2	RF1
0063h	I2C3SBCR	NB7	NB6	NB5	NB4	NB3	NB2	NB1	NB1
0064h	I2C3SSAR1	ADDR7	ADDR6	ADDR5	ADDR4	ADDR3	ADDR2	ADDR1	EN1
0065h	I2C3SCAR1	CA 7 .. CA0							

Table 71. I²C3S register map (continued)

Address (Hex.)	Register name	7	6	5	4	3	2	1	0
0066h	I2C3SSAR2	ADDR7	ADDR6	ADDR5	ADDR4	ADDR3	ADDR2	ADDR1	EN2
0067h	I2C3SCAR2	CA 7 .. CA0							
0068h	I2C3SSAR3	ADDR7	ADDR6	ADDR5	ADDR4	ADDR3	ADDR2	ADDR1	EN3
0069h	I2C3SCAR3	CA 7 .. CA0							

11.8 10-bit A/D converter (ADC)

11.8.1 Introduction

The on-chip Analog to Digital Converter (ADC) peripheral is a 10-bit, successive approximation converter with internal sample and hold circuitry. This peripheral has up to 16 multiplexed analog input channels (refer to device pinout description) that allow the peripheral to convert the analog voltage levels from up to 16 different sources.

The result of the conversion is stored in a 10-bit Data Register. The A/D converter is controlled through a Control/Status Register.

Note: Whenever you change the channel or write in the ADCCSR register, the ADC conversion starts again.

11.8.2 Main features

- 10-bit conversion
- Up to 16 channels with multiplexed input
- Linear successive approximation
- Data register (DR) which contains the results
- Conversion complete status flag
- ON/OFF bit (to reduce consumption)

The block diagram is shown in [Figure 84](#).

Figure 84. ADC block diagram

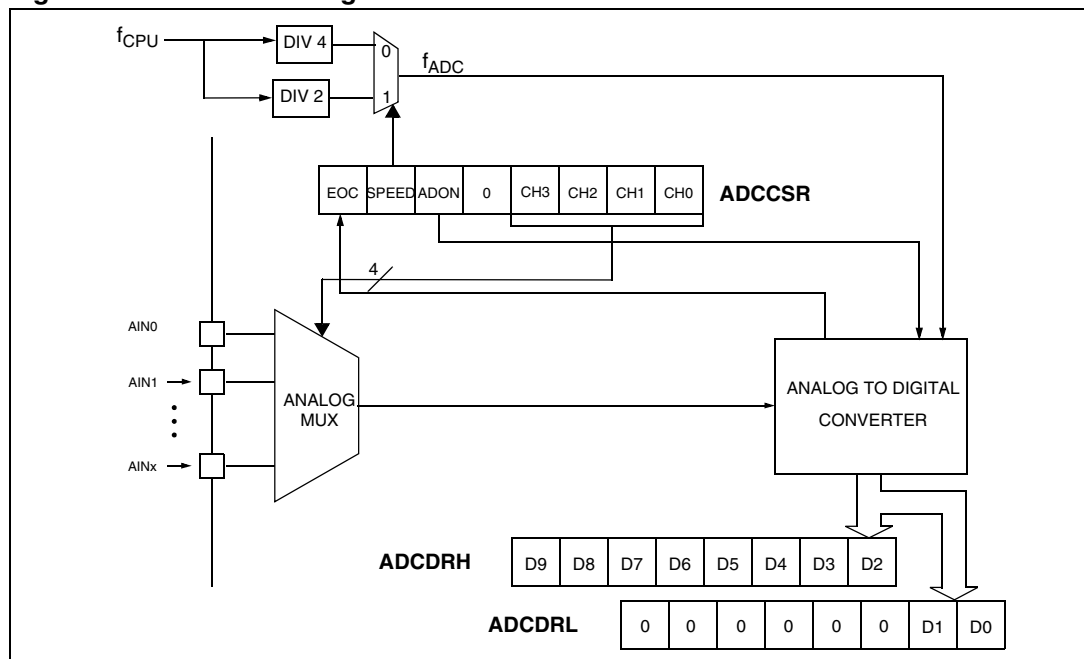

11.8.3 Functional description

The conversion is monotonic, meaning that the result never decreases if the analog input does not, and never increases if the analog input does not.

If the input voltage (V_{AIN}) is greater than V_{AREF} (high-level voltage reference), then the conversion result is FFh in the ADCDRH register and 03h in the ADCDRL register (without overflow indication).

If the input voltage (V_{AIN}) is lower than V_{SSA} (low-level voltage reference), then the conversion result in the ADCDRH and ADCDRL registers is 00 00h.

The A/D converter is linear and the digital result of the conversion is stored in the ADCDRH and ADCDRL registers. The accuracy of the conversion is described in [Section 13: Electrical characteristics](#).

R_{AIN} is the maximum recommended impedance for an analog input signal. If the impedance is too high, this will result in a loss of accuracy due to leakage and sampling not being completed in the allotted time.

A/D converter configuration

The analog input ports must be configured as input, no pull-up, no interrupt. Refer to the «I/O ports» chapter. Using these pins as analog inputs does not affect the ability of the port to be read as a logic input.

In the ADCCSR register:

- Select the CS[3:0] bits to assign the analog channel to convert.

Starting the conversion

In the ADCCSR register:

- Set the ADON bit to enable the A/D converter and to start the conversion. From this time on, the ADC performs a continuous conversion of the selected channel.

When a conversion is complete:

- The EOC bit is set by hardware.
- The result is in the ADCDR registers.

A read to the ADCDRH resets the EOC bit.

To read the 10 bits, perform the following steps:

1. Poll the EOC bit
2. Read the ADCDRL register
3. Read the ADCDRH register. This clears EOC automatically.

Note: The data is not latched, so both the low and the high data register must be read before the next conversion is complete, so it is recommended to disable interrupts while reading the conversion result.

To read only 8 bits, perform the following steps:

1. Poll the EOC bit
2. Read the ADCDRH register. This clears EOC automatically.

Changing the conversion channel

The application can change channels during conversion. When software modifies the CH[3:0] bits in the ADCCSR register, the current conversion is stopped, the EOC bit is cleared, and the A/D converter starts converting the newly selected channel.

11.8.4 Low-power modes

Note: The A/D converter may be disabled by resetting the ADON bit. This feature allows reduced power consumption when no conversion is needed.

Table 72. Mode description

Mode	Description
Wait	No effect on A/D Converter
Halt	A/D Converter disabled. After wakeup from Halt mode, the A/D Converter requires a stabilization time t_{STAB} (see Electrical characteristics) before accurate conversions can be performed.

11.8.5 Interrupts

None.

11.8.6 Register description

Control/status register (ADCCSR)

Reset value: 0000 0000 (00h)

7				0				
EOC	SPEED	ADON	0	CH3	CH2	CH1	CH0	
Read/Write (Except bit 7 read only)								

Bit 7 = **EOC** *End of Conversion*

This bit is set by hardware. It is cleared by hardware when software reads the ADCDRH register or writes to any bit of the ADCCSR register.

0: Conversion is not complete
1: Conversion complete

Bit 6 = **SPEED** *ADC clock selection*

This bit is set and cleared by software.

0: $f_{ADC} = f_{CPU}/4$
1: $f_{ADC} = f_{CPU}/2$

Bit 5 = **ADON** *A/D Converter on*

This bit is set and cleared by software.

0: Disable ADC and stop conversion
1: Enable ADC and start conversion

Bit 4 = **Reserved**. Must be kept cleared.

Bits 3:0 = **CH[3:0]** *Channel Selection*

These bits are set and cleared by software. They select the analog input to convert.

Table 73. Channel selection

Channel pin ⁽¹⁾	CH3	CH2	CH1	CH0
AIN0	0	0	0	0
AIN1	0	0	0	1
AIN2	0	0	1	0
AIN3	0	0	1	1
AIN4	0	1	0	0
AIN5	0	1	0	1
Reserved	0	1	1	0
Reserved	0	1	1	1
AIN8	1	0	0	0
Reserved	1	0	0	1
AIN10	1	0	1	0
Reserved	1	0	1	1
AIN12	1	1	0	0
AIN13	1	1	0	1
AIN14	1	1	1	0
AIN15	1	1	1	1

1. The number of channels is device dependent. Refer to the device pinout description.

Data register (ADCDRH)

Reset value: 0000 0000 (00h)

7							0
D9	D8	D7	D6	D5	D4	D3	D2
Read Only							

Bits 7:0 = **D[9:2]** *MSB of Converted Analog Value*

Data register (ADCDRL)

Reset value: 0000 0000 (00h)

7							0
0	0	0	0	0	0	D1	D0
Read Only							

Bits7:2 = Reserved. Forced by hardware to 0.

Bits 1:0 = **D[1:0]** *LSB of Converted Analog Value*

Table 74. ADC register map and reset values

Address (Hex.)	Register label	7	6	5	4	3	2	1	0
0070h	ADCCSR Reset value	EOC 0	SPEED 0	ADON 0	0	CH3 0	CH2 0	CH1 0	CH0 0
0071h	ADCDRH Reset value	D9 0	D8 0	D7 0	D6 0	D5 0	D4 0	D3 0	D2 0
0072h	ADCDDL Reset value	0	0	0	0	0	0	D1 0	D0 0

12 Instruction set

12.1 ST7 addressing modes

The ST7 Core features 17 different addressing modes which can be classified in seven main groups:

Table 75. Addressing mode groups

Addressing mode	Example
Inherent	nop
Immediate	ld A,#\$55
Direct	ld A,\$55
Indexed	ld A,(\$55,X)
Indirect	ld A,([\$55],X)
Relative	jrne loop
Bit operation	bset byte,#5

The ST7 Instruction set is designed to minimize the number of bytes required per instruction: To do so, most of the addressing modes may be subdivided in two submodes called long and short:

- Long addressing mode is more powerful because it can use the full 64-Kbyte address space; however, it uses more bytes and more CPU cycles.
- Short addressing mode is less powerful because it can generally only access page zero (0000h - 00FFh range), but the instruction size is more compact, and faster. All memory-to-memory instructions use short addressing modes only (CLR, CPL, NEG, BSET, BRES, BTJT, BTJF, INC, DEC, RLC, RRC, SLL, SRL, SRA, SWAP)

The ST7 Assembler optimizes the use of long and short addressing modes.

Table 76. ST7 addressing mode overview

Mode		Syntax	Destination/ source	Pointer address	Pointer size (hex.)	Length (bytes)
Inherent		nop				+ 0
Immediate		ld A,#\$55				+ 1
Short	Direct	ld A,\$10	00..FF			+ 1
Long	Direct	ld A,\$1000	0000..FFFF			+ 2
No Offset	Direct	Indexed	ld A,(X)	00..FF		+ 0 (with X register) + 1 (with Y register)
Short	Direct	Indexed	ld A,(\$10,X)	00..1FE		+ 1
Long	Direct	Indexed	ld A,(\$1000,X)	0000..FFFF		+ 2
Short	Indirect		ld A,[\$10]	00..FF	00..FF	byte + 2
Long	Indirect		ld A,[\$10.w]	0000..FFFF	00..FF	word + 2

Table 76. ST7 addressing mode overview (continued)

Mode			Syntax	Destination/ source	Pointer address	Pointer size (hex.)	Length (bytes)
Short	Indirect	Indexed	ld A,([\$10],X)	00..1FE	00..FF	byte	+ 2
Long	Indirect	Indexed	ld A,([\$10.w],X)	0000..FFFF	00..FF	word	+ 2
Relative	Direct		jrne loop	PC-128/PC+127 ⁽¹⁾			+ 1
Relative	Indirect		jrne [\$10]	PC-128/PC+127 ⁽¹⁾	00..FF	byte	+ 2
Bit	Direct		bset \$10,#7	00..FF			+ 1
Bit	Indirect		bset [\$10],#7	00..FF	00..FF	byte	+ 2
Bit	Direct	Relative	btjt \$10,#7,skip	00..FF			+ 2
Bit	Indirect	Relative	btjt [\$10],#7,skip	00..FF	00..FF	byte	+ 3

1. At the time the instruction is executed, the Program Counter (PC) points to the instruction following JRxx.

12.1.1 Inherent

All Inherent instructions consist of a single byte. The opcode fully specifies all the required information for the CPU to process the operation.

Table 77. Inherent instructions

Inherent instruction	Function
NOP	No operation
TRAP	S/W Interrupt
WFI	Wait for interrupt (low-power mode)
HALT	Halt oscillator (lowest power mode)
RET	Subroutine return
IRET	Interrupt subroutine return
SIM	Set interrupt mask
RIM	Reset interrupt mask
SCF	Set carry flag
RCF	Reset carry flag
RSP	Reset stack pointer
LD	Load
CLR	Clear
PUSH/POP	Push/Pop to/from the stack
INC/DEC	Increment/Decrement
TNZ	Test negative or zero
CPL, NEG	1 or 2 complement
MUL	Byte Multiplication

Table 77. Inherent instructions (continued)

Inherent instruction	Function
SLL, SRL, SRA, RLC, RRC	Shift and Rotate Operations
SWAP	Swap Nibbles

12.1.2 Immediate

Immediate instructions have 2 bytes; the first byte contains the opcode, the second byte contains the operand value.

Table 78. Immediate instructions

Immediate instruction	Function
LD	Load
CP	Compare
BCP	Bit Compare
AND, OR, XOR	Logical Operations
ADC, ADD, SUB, SBC	Arithmetic Operations

12.1.3 Direct

In Direct instructions, the operands are referenced by their memory address.

The direct addressing mode consists of two submodes:

Direct (Short)

The address is a byte, thus requires only 1 byte after the opcode, but only allows 00 - FF addressing space.

Direct (Long)

The address is a word, thus allowing 64-Kbyte addressing space, but requires 2 bytes after the opcode.

12.1.4 Indexed (No Offset, Short, Long)

In this mode, the operand is referenced by its memory address, which is defined by the unsigned addition of an index register (X or Y) with an offset.

The indirect addressing mode consists of three submodes:

Indexed (No offset)

There is no offset (no extra byte after the opcode), and allows 00 - FF addressing space.

- Indexed (Short)
The offset is a byte, thus requires only 1 byte after the opcode and allows 00 - 1FE addressing space.
- Indexed (Long)
The offset is a word, thus allowing 64-Kbyte addressing space and requires 2 bytes after the opcode.

12.1.5 Indirect (Short, Long)

The required data byte to do the operation is found by its memory address, located in memory (pointer).

The pointer address follows the opcode. The indirect addressing mode consists of two submodes:

Indirect (Short)

The pointer address is a byte, the pointer size is a byte, thus allowing 00 - FF addressing space, and requires 1 byte after the opcode.

Indirect (Long)

The pointer address is a byte, the pointer size is a word, thus allowing 64-Kbyte addressing space, and requires 1 byte after the opcode.

12.1.6 Indirect Indexed (Short, Long)

This is a combination of indirect and short indexed addressing modes. The operand is referenced by its memory address, which is defined by the unsigned addition of an index register value (X or Y) with a pointer value located in memory. The pointer address follows the opcode.

The indirect indexed addressing mode consists of two submodes:

Indirect Indexed (Short)

The pointer address is a byte, the pointer size is a byte, thus allowing 00 - 1FE addressing space, and requires 1 byte after the opcode.

Indirect Indexed (Long)

The pointer address is a byte, the pointer size is a word, thus allowing 64-Kbyte addressing space, and requires 1 byte after the opcode.

Table 79. Instructions supporting direct, indexed, indirect and indirect indexed addressing modes

Long and short instructions	Function
LD	Load
CP	Compare
AND, OR, XOR	Logical Operations
ADC, ADD, SUB, SBC	Arithmetic Addition/subtraction operations
BCP	Bit Compare

Table 80. Short instructions

Short instructions only	Function
CLR	Clear
INC, DEC	Increment/Decrement
TNZ	Test Negative or Zero
CPL, NEG	1 or 2 Complement
BSET, BRES	Bit Operations
BTJT, BTJF	Bit Test and Jump Operations
SLL, SRL, SRA, RLC, RRC	Shift and Rotate Operations
SWAP	Swap Nibbles
CALL, JP	Call or Jump subroutine

12.1.7 Relative Mode (direct, indirect)

This addressing mode is used to modify the PC register value by adding an 8-bit signed offset to it.

Table 81. Relative direct/indirect instructions

Available relative direct/indirect instructions	Function
JRxx	Conditional Jump
CALLR	Call Relative

The relative addressing mode consists of two submodes:

Relative (Direct)

The offset follows the opcode.

Relative (Indirect)

The offset is defined in memory, of which the address follows the opcode.

12.2 Instruction groups

The ST7 family devices use an instruction set consisting of 63 instructions. The instructions may be subdivided into 13 main groups as illustrated in the following table:

Table 82. Main instruction groups

Load and Transfer	LD	CLR						
Stack operation	PUSH	POP	RSP					
Increment/Decrement	INC	DEC						
Compare and Tests	CP	TNZ	BCP					
Logical operations	AND	OR	XOR	CPL	NEG			
Bit Operation	BSET	BRES						
Conditional Bit Test and Branch	BTJT	BTJF						
Arithmetic operations	ADC	ADD	SUB	SBC	MUL			
Shift and Rotates	SLL	SRL	SRA	RLC	RRC	SWAP	SLA	
Unconditional Jump or Call	JRA	JRT	JRF	JP	CALL	CALLR	NOP	RET
Conditional Branch	JRxx							
Interruption management	TRAP	WFI	HALT	IRET				
Condition Code Flag modification	SIM	RIM	SCF	RCF				

Using a prebyte

The instructions are described with 1 to 4 bytes.

In order to extend the number of available opcodes for an 8-bit CPU (256 opcodes), three different prebyte opcodes are defined. These prebytes modify the meaning of the instruction they precede.

The whole instruction becomes:

- PC-2 End of previous instruction
- PC-1 Prebyte
- PC Opcode
- PC+1 Additional word (0 to 2) according to the number of bytes required to compute the effective address

These prebytes enable instruction in Y as well as indirect addressing modes to be implemented. They precede the opcode of the instruction in X or the instruction using direct addressing mode. The prebytes are:

PDY 90 Replace an X-based instruction using immediate, direct, indexed, or inherent addressing mode by a Y one.

PIX 92 Replace an instruction using direct, direct bit or direct relative addressing mode to an instruction using the corresponding indirect addressing mode.

It also changes an instruction using X indexed addressing mode to an instruction using indirect X indexed addressing mode.

PIY 91 Replace an instruction using X indirect indexed addressing mode by a Y one.

12.2.1 Illegal opcode reset

In order to provide enhanced robustness to the device against unexpected behavior, a system of illegal opcode detection is implemented. If a code to be executed does not correspond to any opcode or prebyte value, a reset is generated. This, combined with the Watchdog, allows the detection and recovery from an unexpected fault or interference.

Note: A valid prebyte associated with a valid opcode forming an unauthorized combination does not generate a reset.

Table 83. Illegal opcode detection

Mnemo	Description	Function/Example	Dst	Src	H	I	N	Z	C
ADC	Add with Carry	$A = A + M + C$	A	M	H		N	Z	C
ADD	Addition	$A = A + M$	A	M	H		N	Z	C
AND	Logical And	$A = A . M$	A	M			N	Z	
BCP	Bit compare A, Memory	tst (A . M)	A	M			N	Z	
BRES	Bit Reset	bres Byte, #3	M						
BSET	Bit Set	bset Byte, #3	M						
BTJF	Jump if bit is false (0)	btjf Byte, #3, Jmp1	M						C
BTJT	Jump if bit is true (1)	btjt Byte, #3, Jmp1	M						C
CALL	Call subroutine								
CALLR	Call subroutine relative								
CLR	Clear		reg, M				0	1	
CP	Arithmetic Compare	tst(Reg - M)	reg	M			N	Z	C
CPL	One Complement	$A = FFH-A$	reg, M				N	Z	1
DEC	Decrement	dec Y	reg, M				N	Z	
HALT	Halt					0			
IRET	Interrupt routine return	Pop CC, A, X, PC			H	I	N	Z	C
INC	Increment	inc X	reg, M				N	Z	
JP	Absolute Jump	jp [TBL.w]							
JRA	Jump relative always								
JRT	Jump relative								
JRF	Never jump	jrf *							
JRIH	Jump if ext. interrupt = 1								
JRIL	Jump if ext. interrupt = 0								
JRH	Jump if H = 1	H = 1 ?							
JRNH	Jump if H = 0	H = 0 ?							

Table 83. Illegal opcode detection (continued)

Mnemo	Description	Function/Example	Dst	Src	H	I	N	Z	C
JRM	Jump if I = 1	I = 1 ?							
JRNM	Jump if I = 0	I = 0 ?							
JRMI	Jump if N = 1 (minus)	N = 1 ?							
JRPL	Jump if N = 0 (plus)	N = 0 ?							
JREQ	Jump if Z = 1 (equal)	Z = 1 ?							
JRNE	Jump if Z = 0 (not equal)	Z = 0 ?							
JRC	Jump if C = 1	C = 1 ?							
JRNC	Jump if C = 0	C = 0 ?							
JRULT	Jump if C = 1	Unsigned <							
JRUGE	Jump if C = 0	Jmp if unsigned >=							
JRUGT	Jump if (C + Z = 0)	Unsigned >							
JRULE	Jump if (C + Z = 1)	Unsigned <=							
LD	Load	dst <= src	reg, M	M, reg			N	Z	
MUL	Multiply	X,A = X * A	A, X, Y	X, Y, A	0				0
NEG	Negate (2's compl)	neg \$10	reg, M				N	Z	C
NOP	No Operation								
OR	OR operation	A = A + M	A	M			N	Z	
POP	Pop from the Stack	pop reg	reg	M					
		pop CC	CC	M	H	I	N	Z	C
PUSH	Push onto the Stack	push Y	M	reg, CC					
RCF	Reset carry flag	C = 0							0
RET	Subroutine Return								
RIM	Enable Interrupts	I = 0				0			
RLC	Rotate left true C	C <= Dst <= C	reg, M				N	Z	C
RRC	Rotate right true C	C => Dst => C	reg, M				N	Z	C
RSP	Reset Stack Pointer	S = Max allowed							
SBC	Subtract with Carry	A = A - M - C	A	M			N	Z	C
SCF	Set carry flag	C = 1							1
SIM	Disable Interrupts	I = 1				1			
SLA	Shift left Arithmetic	C <= Dst <= 0	reg, M				N	Z	C
SLL	Shift left Logic	C <= Dst <= 0	reg, M				N	Z	C
SRL	Shift right Logic	0 => Dst => C	reg, M				0	Z	C
SRA	Shift right Arithmetic	Dst7 => Dst => C	reg, M				N	Z	C

Table 83. Illegal opcode detection (continued)

Mnemo	Description	Function/Example	Dst	Src	H	I	N	Z	C
SUB	Subtraction	$A = A - M$	A	M			N	Z	C
SWAP	SWAP nibbles	$Dst[7..4] \Leftrightarrow Dst[3..0]$	reg, M				N	Z	
TNZ	Test for Neg & Zero	tnz lbl1					N	Z	
TRAP	S/W trap	S/W interrupt				1			
WFI	Wait for Interrupt					0			
XOR	Exclusive OR	$A = A \text{ XOR } M$	A	M			N	Z	

13 Electrical characteristics

13.1 Parameter conditions

Unless otherwise specified, all voltages are referred to V_{SS} .

13.1.1 Minimum and maximum values

Unless otherwise specified, the minimum and maximum values are guaranteed in the worst conditions of ambient temperature, supply voltage and frequencies by tests in production on 100% of the devices with an ambient temperature at $T_A=25^\circ\text{C}$ and $T_A=T_A\text{max}$ (given by the selected temperature range).

Data based on characterization results, design simulation and/or technology characteristics are indicated in the table footnotes and are not tested in production. Based on characterization, the minimum and maximum values refer to sample tests and represent the mean value plus or minus three times the standard deviation ($\text{mean}\pm 3\Sigma$).

13.1.2 Typical values

Unless otherwise specified, typical data are based on $T_A = 25^\circ\text{C}$, $V_{DD} = 5\text{ V}$ (for the $4.5\text{ V} \leq V_{DD} \leq 5.5\text{ V}$ voltage range) and $V_{DD} = 3.3\text{ V}$ (for the $3\text{ V} \leq V_{DD} \leq 3.6\text{ V}$ voltage range). They are given only as design guidelines and are not tested.

13.1.3 Typical curves

Unless otherwise specified, all typical curves are given only as design guidelines and are not tested.

13.1.4 Loading capacitor

The loading conditions used for pin parameter measurement are shown in [Figure 85](#).

Figure 85. Pin loading conditions

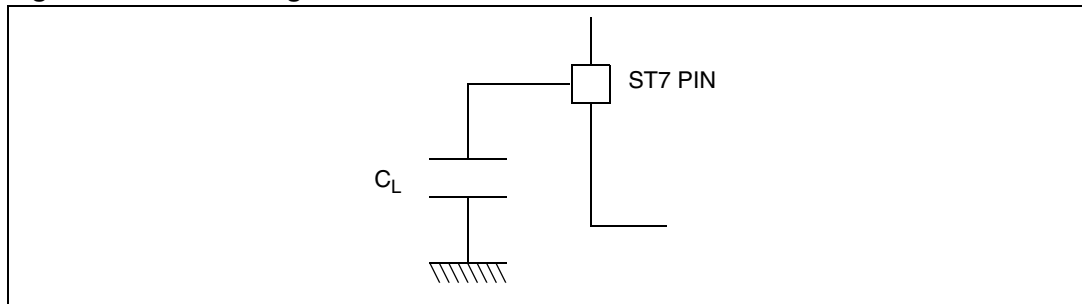

13.1.5 Pin input voltage

The input voltage measurement on a pin of the device is described in [Figure 86](#).

Figure 86. Pin input voltage

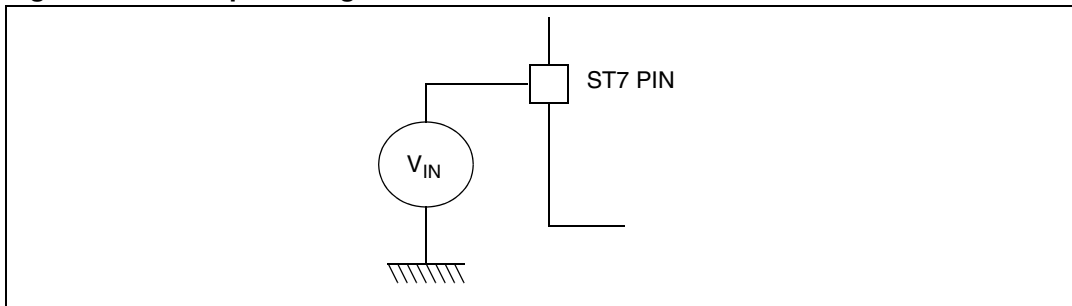

13.2 Absolute maximum ratings

Stresses above those listed as “absolute maximum ratings” may cause permanent damage to the device. This is a stress rating only and functional operation of the device under these conditions is not implied. Exposure to maximum rating conditions for extended periods may affect device reliability.

Table 84. Voltage characteristics

Symbol	Ratings	Maximum value	Unit
$V_{DD} - V_{SS}$	Supply voltage	7.0	V
V_{IN}	Input voltage on any pin ⁽¹⁾⁽²⁾	$V_{SS}-0.3$ to $V_{DD}+0.3$	
$ V_{DDx} - V_{DD} $	Variations between different power pins	0.3	
$ V_{SSx} - V_{SS} $	Variations between all the different ground pins	0.3	
$V_{ESD(HBM)}$	Electrostatic discharge voltage (human body model)	see Section 13.8.3: Absolute maximum ratings (electrical sensitivity)	

1. Directly connecting the \overline{RESET} and I/O pins to V_{DD} or V_{SS} could damage the device if an unintentional internal reset is generated or an unexpected change of the I/O configuration occurs (for example, due to a corrupted program counter). To guarantee safe operation, this connection has to be done through a pull-up or pull-down resistor (typical: 4.7 k Ω for \overline{RESET} , 10 k Ω for I/Os). Unused I/O pins must be tied in the same way to V_{DD} or V_{SS} according to their reset configuration.
2. $I_{INJ(PIN)}$ must never be exceeded. This is implicitly insured if V_{IN} maximum is respected. If V_{IN} maximum cannot be respected, the injection current must be limited externally to the $I_{INJ(PIN)}$ value. A positive injection is induced by $V_{IN} > V_{DD}$ while a negative injection is induced by $V_{IN} < V_{SS}$. For true open-drain pads, there is no positive injection current, and the corresponding V_{IN} maximum must always be respected

Table 85. Current characteristics

Symbol	Ratings	Maximum value	Unit
I_{VDD}	Total current into V_{DD} power lines (source) ⁽¹⁾	75	mA
I_{VSS}	Total current out of V_{SS} ground lines (sink) ⁽¹⁾	150	
I_{IO}	Output current sunk by any standard I/O and control pin	20	
	Output current sunk by any high sink I/O pin	40	
	Output current source by any I/Os and control pin	- 25	
$I_{INJ(PIN)}$ ⁽²⁾⁽³⁾	Injected current on ISPSEL pin	± 5	
	Injected current on \overline{RESET} pin	± 5	
	Injected current on OSC1 and OSC2 pins	± 5	
	Injected current on PB0 pin ⁽⁴⁾	+5	
	Injected current on any other pin ⁽⁵⁾	± 5	
$\Sigma I_{INJ(PIN)}$ ⁽²⁾	Total injected current (sum of all I/O and control pins) ⁽⁵⁾	± 20	

1. All power (V_{DD}) and ground (V_{SS}) lines must always be connected to the external supply.
2. $I_{INJ(PIN)}$ must never be exceeded. This is implicitly insured if V_{IN} maximum is respected. If V_{IN} maximum cannot be respected, the injection current must be limited externally to the $I_{INJ(PIN)}$ value. A positive injection is induced by $V_{IN} > V_{DD}$ while a negative injection is induced by $V_{IN} < V_{SS}$. For true open-drain pads, there is no positive injection current, and the corresponding V_{IN} maximum must always be respected
3. Negative injection disturbs the analog performance of the device. In particular, it induces leakage currents throughout the device including the analog inputs. To avoid undesirable effects on the analog functions, care must be taken:
 - Analog input pins must have a negative injection less than 0.8 mA (assuming that the impedance of the analog voltage is lower than the specified limits)
 - Pure digital pins must have a negative injection less than 1.6 mA. In addition, it is recommended to inject the current as far as possible from the analog input pins.
4. No negative current injection allowed on PB0 pin.
5. When several inputs are submitted to a current injection, the maximum $\Sigma I_{INJ(PIN)}$ is the absolute sum of the positive and negative injected currents (instantaneous values). These results are based on characterisation with $\Sigma I_{INJ(PIN)}$ maximum current injection on four I/O port pins of the device.

Table 86. Thermal characteristics

Symbol	Ratings	Value	Unit
T_{STG}	Storage temperature range	-65 to +150	°C
T_J	Maximum junction temperature (see Table 118)		

13.3 Operating conditions

Table 87. General operating conditions (1)

Symbol	Parameter	Conditions	Min	Max	Unit
V _{DD}	Supply voltage	f _{CPU} = 8 MHz. max.	3.3	5.5	V
		f _{CPU} = 4 MHz. max.	2.7	5.5	
f _{OSC}	External clock frequency	3.3 V ≤ V _{DD} ≤ 5.5 V	Up to 16		MHz
		2.7 V ≤ V _{DD} < 3.3 V	Up to 8		

1. T_A = -40 to +85 °C unless otherwise specified.

Note: When the power supply is between 2.7 and 2.95 V (V_{IT+(LVD)} max), the device is either in the guaranteed functional area or in reset state, thus allowing a deterministic application behavior. However, the LVD may generate a reset below 2.95 V and the user should therefore not use the device below this level when the LVD is enabled.

Figure 87. f_{CPU} maximum operating frequency versus V_{DD} supply voltage

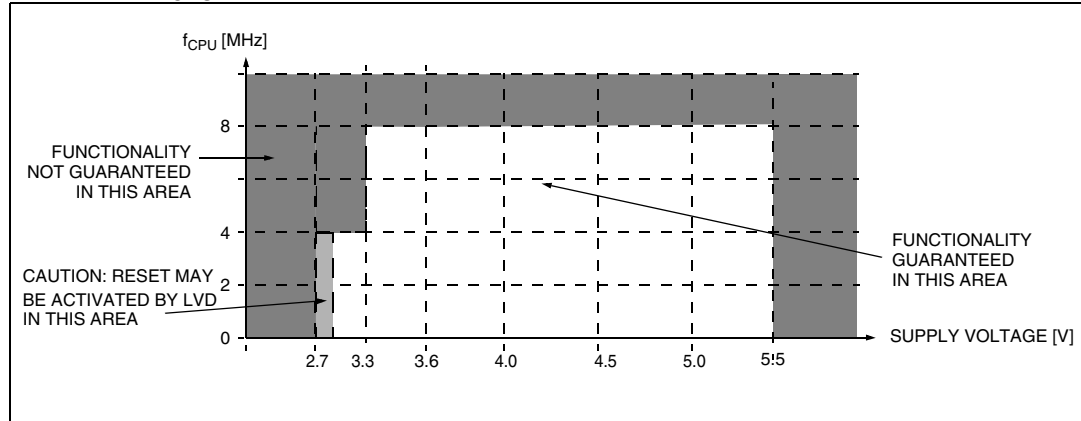

Table 88. LVD thresholds

Symbol	Parameter	Conditions (1)	Min	Typ	Max	Unit
V _{IT+(LVD)}	Reset release threshold (V _{DD} rise)	High threshold	3.85	4.20	4.61	V
		Med. threshold	3.24	3.56	3.90	
		Low threshold	2.60	2.88	3.14	
V _{IT-(LVD)}	Reset generation threshold (V _{DD} fall)	High threshold	3.66	3.98	4.36	V
		Med. threshold	3.04	3.36	3.66	
		Low threshold	2.45	2.71	2.95	
V _{hys(LVD)}	LVD voltage threshold hysteresis	V _{IT+(LVD)} - V _{IT-(LVD)}		200		mV
Vt _{POR}	V _{DD} rise time rate		20 (2)		100 (2)	ms/V
t _{g(VDD)}	V _{DD} glitches filtered by LVD			150		ns

1. T_A = -40 to +85 °C unless otherwise specified.

2. Not tested in production, guaranteed by design

Table 89. AVD thresholds

Symbol	Parameter	Conditions ⁽¹⁾	Min ⁽²⁾	Typ	Max ⁽²⁾	Unit
$V_{IT+(AVD)}$	1=>0 AVDF flag toggle threshold (V_{DD} rise)	High threshold Med. threshold Low threshold	4.15 3.64 3.00	4.50 3.96 3.28	4.91 4.30 3.54	V
$V_{IT-(AVD)}$	0=>1 AVDF flag toggle threshold (V_{DD} fall)	High threshold Med. threshold Low threshold	3.96 3.44 2.85	4.28 3.76 3.11	4.66 4.06 3.35	
$V_{hys(AVD)}$	AVD voltage threshold hysteresis	$V_{IT+(AVD)} - V_{IT-(AVD)}$		200		mV
ΔV_{IT-}	Voltage drop between ADV flag set and LVD reset activated	$V_{IT-(AVD)} - V_{IT-(LVD)}$		450		mV

1. $T_A = -40$ to $+85^\circ\text{C}$ unless otherwise specified.

2. Not tested in production, guaranteed by characterization.

Table 90. PLL characteristics

Symbol	Parameter	Conditions	Min	Typ	Max	Unit
f_{PLLIN}	PLL Input frequency ⁽¹⁾	$V_{DD} = 2.7$ to 3.65 V PLL option x4 selected	0.95	1	1.05	MHz
		$V_{DD} = 3.3$ to 5.5 V PLL option x8 selected	0.90	1	1.10	
$V_{DD(PLL)}$	PLL operating range	PLL option x4 selected ⁽²⁾	2.7		3.65	V
		PLL option x8 selected	3.3		5.5	
$t_{w(JIT)}$	PLL jitter period	$f_{RC} = 1$ MHz		8		kHz
JIT_{PLL}	PLL jitter ($\Delta f_{CPU}/f_{CPU}$)	$V_{DD} = 3.0$ V		3.0		%
		$V_{DD} = 5.0$ V		1.6		
$I_{DD(PLL)}$	PLL current consumption	$T_A = 25^\circ\text{C}$		600		μA

1. Guaranteed by design.

2. To obtain a x4 multiplication ratio in the range 3.3 to 5.5V, the DIV2EN option bit must be enabled.

The ST7 internal clock can be supplied by an internal RC oscillator and PLL (selectable by option byte).

Table 91. Internal RC oscillator and PLL

Symbol	Parameter	Conditions	Min	Typ	Max	Unit
$V_{DD(RC)}$	Internal RC oscillator operating voltage	Refer to operating range of V_{DD} with T_A , Table 87	2.7		5.5	V
$V_{DD(x4PLL)}$	x4 PLL operating voltage		2.7		5.5	
$V_{DD(x8PLL)}$	x8 PLL operating voltage		3.3		5.5	
$t_{STARTUP}$	PLL Startup time			60		PLL input clock (f_{PLL}) cycles

13.4 Internal RC oscillator characteristics

Table 92. Internal RC oscillator characteristics

Symbol	Parameter	Conditions	Min	Typ	Max	Unit
f_{RC}	Internal RC oscillator frequency ⁽¹⁾	RCCR = FF (reset value), $T_A = 25\text{ }^\circ\text{C}$, $V_{DD} = 5\text{ V}$		625		kHz
		RCCR = RCCR0 ⁽²⁾ , $T_A = 25\text{ }^\circ\text{C}$, $V_{DD} = 5\text{ V}$		1000		
		RCCR = FF (reset value), $T_A = 25\text{ }^\circ\text{C}$, $V_{DD} = 3\text{ V}$		612		
		RCCR = RCCR1 ⁽²⁾ , $T_A = 25\text{ }^\circ\text{C}$, $V_{DD} = 3\text{ V}$		1000		
ACC_{RC}	Accuracy of Internal RC oscillator with RCCR=RCCR0 ⁽²⁾	$T_A = 25\text{ }^\circ\text{C}$, $V_{DD} = 5\text{ V}$	-1		+1	%
		$T_A = 25\text{ }^\circ\text{C}$, $V_{DD} = 4.5\text{ to }5.5\text{ V}$ ⁽³⁾	-1		+1	%
		$T_A = 25\text{ to }+85\text{ }^\circ\text{C}$, $V_{DD} = 5\text{ V}$ ⁽³⁾	-3		+3	%
		$T_A = 25\text{ to }+85\text{ }^\circ\text{C}$, $V_{DD} = 4.5\text{ to }5.5\text{ V}$ ⁽³⁾	-3.5		+3.5	%
		$T_A = -40\text{ to }+25\text{ }^\circ\text{C}$, $V_{DD} = 4.5\text{ to }5.5\text{ V}$ ⁽³⁾	-3		+7	%
$I_{DD(RC)}$	RC oscillator current consumption	$T_A = 25\text{ }^\circ\text{C}$, $V_{DD} = 5\text{ V}$		600 ⁽³⁾		μA
$t_{su(RC)}$	RC oscillator setup time	$T_A = 25\text{ }^\circ\text{C}$, $V_{DD} = 5\text{ V}$			10 ⁽²⁾	μs

1. If the RC oscillator clock is selected, to improve clock stability and frequency accuracy, it is recommended to place a decoupling capacitor, typically 100 nF, between the V_{DD} and V_{SS} pins as close as possible to the ST7 device. It is also recommended to perform the calibration on board.
2. See [Internal RC oscillator](#).
3. Expected results. Data based on characterization, not tested in production.

Figure 88. Typical RC frequency vs. RCCR

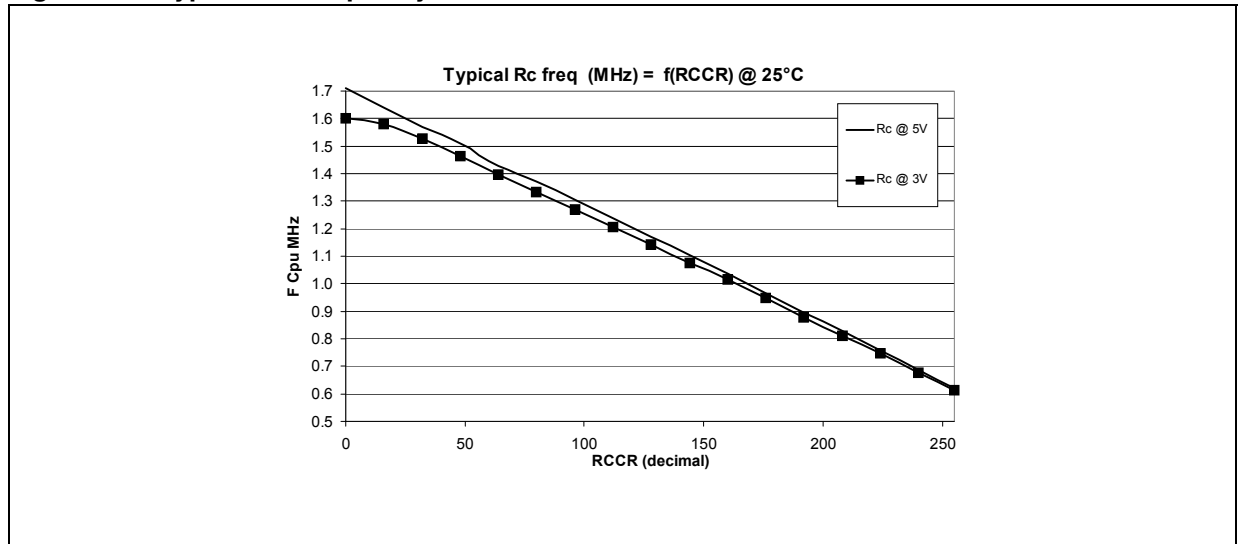

13.5 Supply current characteristics

The following current consumption specified for the ST7 functional operating modes over temperature range does not take into account the clock source current consumption. To get the total device consumption, the two current values must be added (except for Halt mode for which the clock is stopped).

Table 93. Supply current

Symbol	Parameter	Conditions ⁽¹⁾	Typ	Max	Unit	
I _{DD}	Supply current in Run mode	V _{DD} =5.5V	f _{CPU} = 8 MHz ⁽²⁾	8.5	13	mA
	Supply current in Wait mode		f _{CPU} = 8 MHz ⁽³⁾	3.7	6	
	Supply current in Slow mode		f _{CPU} = 250 kHz ⁽⁴⁾	4.1	7	
	Supply current in Slow-wait mode		f _{CPU} = 250 kHz ⁽⁵⁾	2.2	3.5	
	Supply current in Halt mode ⁽⁶⁾		-40°C ≤ T _A ≤ +85 °C	1	10	μA
	Supply current in AWUFH mode ⁽⁷⁾⁽⁸⁾		T _A = +25 °C	50	60	
	Supply current in Active-halt mode ⁽⁶⁾⁽⁷⁾		T _A = +25 °C	500	700	

1. T_A = -40 to +85°C unless otherwise specified
2. CPU running with memory access, all I/O pins in input mode with a static value at V_{DD} or V_{SS} (no load), all peripherals in reset state; clock input (OSC1) driven by external square wave, LVD disabled.
3. All I/O pins in input mode with a static value at V_{DD} or V_{SS} (no load), all peripherals in reset state; clock input (OSC1) driven by external square wave, LVD disabled.
4. Slow mode selected with f_{CPU} based on f_{OSC} divided by 32. All I/O pins in input mode with a static value at V_{DD} or V_{SS} (no load), all peripherals in reset state; clock input (OSC1) driven by external square wave, LVD disabled.
5. Slow-wait mode selected with f_{CPU} based on f_{OSC} divided by 32. All I/O pins in input mode with a static value at V_{DD} or V_{SS} (no load), all peripherals in reset state; clock input (OSC1) driven by external square wave, LVD disabled.
6. All I/O pins in output mode with a static value at V_{SS} (no load), LVD disabled. Data based on characterization results, tested in production at V_{DD} max and f_{CPU} max.
7. All I/O pins in input mode with a static value at V_{DD} or V_{SS} (no load). Data tested in production at V_{DD} max. and f_{CPU} max.
8. This consumption refers to the Halt period only and not the associated run period which is software dependent.

Figure 89. Typical I_{DD} in Run vs. f_{CPU}

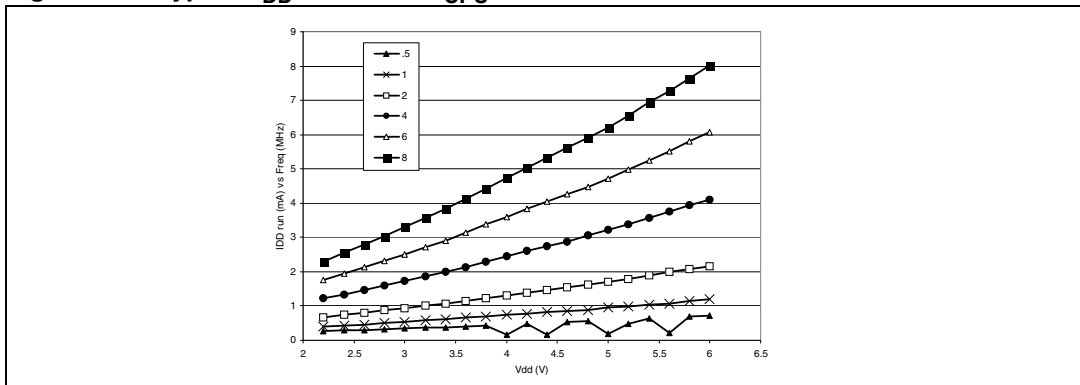

1. Graph displays data beyond the normal operating range of 3 V - 5.5 V.

Figure 90. Typical I_{DD} in Run at $f_{CPU} = 8$ MHz

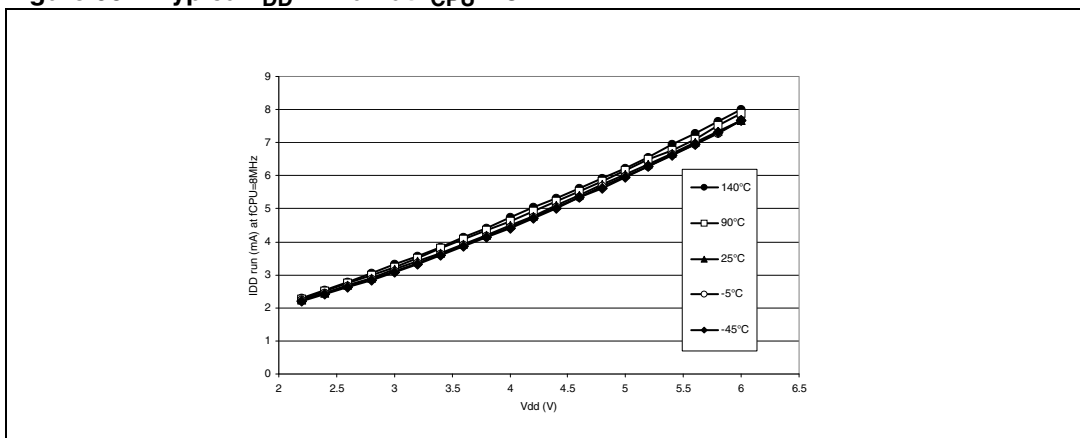

1. Graph displays data beyond the normal operating range of 3 V - 5.5 V.

Figure 91. Typical I_{DD} in Slow vs. f_{CPU}

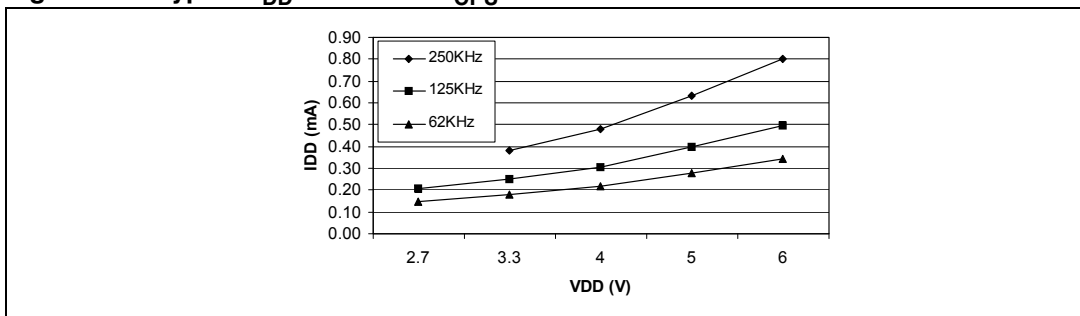

1. Graph displays data beyond the normal operating range of 3 V - 5.5 V.

Figure 92. Typical I_{DD} in Wait vs. f_{CPU}

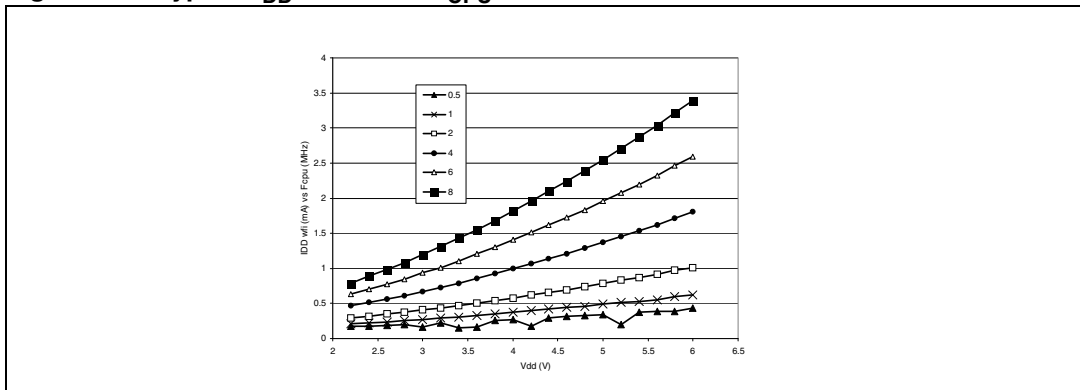

1. Graph displays data beyond the normal operating range of 3 V - 5.5 V.

Figure 93. Typical I_{DD} in Wait at $f_{CPU} = 8$ MHz

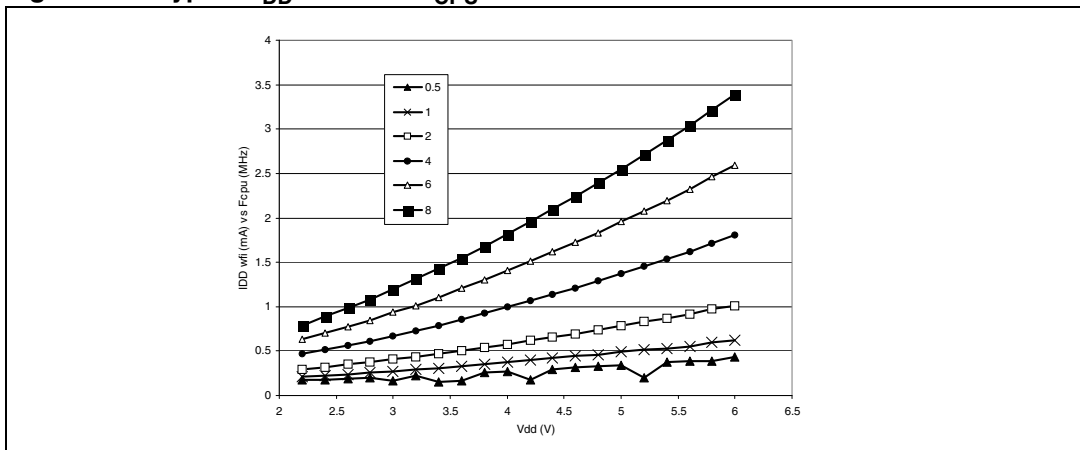

1. Graph displays data beyond the normal operating range of 3 V - 5.5 V.

Figure 94. Typical I_{DD} in Slow-wait vs. f_{CPU}

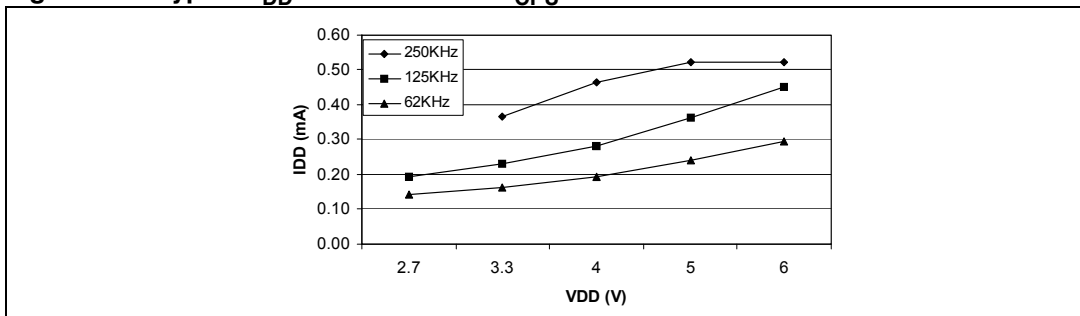

1. Graph displays data beyond the normal operating range of 3 V - 5.5 V.

Figure 95. Typical I_{DD} vs. temp. at V_{DD} = 5 V and f_{CPU} = 8 MHz

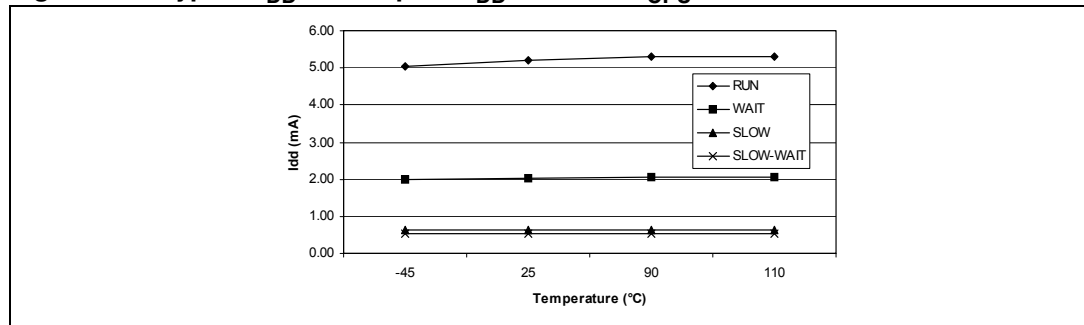

Table 94. On-chip peripherals

Symbol	Parameter	Conditions		Typ	Unit
I _{DD} (16-bit timer)	16-bit Timer supply current ⁽¹⁾	f _{CPU} = 4 MHz	V _{DD} = 3.0 V	20	μA
		f _{CPU} = 8 MHz	V _{DD} = 5.0 V	100	
I _{DD} (SPI)	SPI supply current ⁽²⁾	f _{CPU} = 4 MHz	V _{DD} = 3.0 V	250	
		f _{CPU} = 8 MHz	V _{DD} = 5.0 V	800	
I _{DD} (ADC)	ADC supply current when converting ⁽³⁾	f _{ADC} = 2 MHz	V _{DD} = 3.0 V	300	
		f _{ADC} = 4 MHz	V _{DD} = 5.0 V	1000	
I _{DD} (I2C)	I2C supply current ⁽⁴⁾	f _{CPU} = 4 MHz	V _{DD} = 3.0 V	100	
		f _{CPU} = 8 MHz	V _{DD} = 5.0 V	500	
I _{DD} (SCI)	SCI supply current ⁽⁵⁾	f _{CPU} = 4 MHz	V _{DD} = 3.0 V	250	
		f _{CPU} = 8 MHz	V _{DD} = 5.0 V	800	

1. Data based on a differential I_{DD} measurement between reset configuration (timer stopped) and a timer running in PWM mode at f_{cpu}=8 MHz.
2. Data based on a differential I_{DD} measurement between reset configuration and a permanent SPI master communication (data sent equal to 55h).
3. Data based on a differential I_{DD} measurement between reset configuration and continuous A/D conversions.
4. Data based on a differential I_{DD} measurement between reset configuration (I2C disabled) and a permanent I2C master communication at 100 kHz (data sent equal to 55h). This measurement include the pad toggling consumption (4.7 kΩ external pull-up on clock and data lines).
5. Data based on a differential I_{DD} measurement between SCI low power state (SCID=1) and a permanent SCI data transmit sequence.

13.6 Clock and timing characteristics

Subject to general operating conditions for V_{DD} , f_{OSC} , and T_A .

Table 95. General timings

Symbol	Parameter ⁽¹⁾	Conditions	Min	Typ ⁽²⁾	Max	Unit
$t_{c(INST)}$	Instruction cycle time	$f_{CPU}=8\text{ MHz}$	2	3	12	t_{CPU}
			250	375	1500	ns
$t_{v(IT)}$	Interrupt reaction time ⁽³⁾ $t_{v(IT)} = \Delta t_{c(INST)} + 10$	$f_{CPU}=8\text{ MHz}$	10		22	t_{CPU}
			1.25		2.75	μs

1. Guaranteed by Design. Not tested in production.
2. Data based on typical application software.
3. Time measured between interrupt event and interrupt vector fetch. $Dtc(INST)$ is the number of t_{CPU} cycles needed to finish the current instruction execution.

Table 96. External clock source

Symbol	Parameter	Conditions	Min	Max	Unit
V_{OSC1H}	OSC1 input pin high level voltage	see Figure 96	$0.7 \times V_{DD}$	V_{DD}	V
V_{OSC1L}	OSC1 input pin low level voltage		V_{SS}	$0.3 \times V_{DD}$	
$t_w(OSC1H)$ $t_w(OSC1L)$	OSC1 high or low time ⁽¹⁾		15		ns
$t_r(OSC1)$ $t_f(OSC1)$	OSC1 rise or fall time ⁽¹⁾			15	
I_L	OSCx Input leakage current	$V_{SS} \leq V_{IN} \leq V_{DD}$		± 1	μA

1. Data based on design simulation and/or technology characteristics, not tested in production.

Figure 96. Typical application with an external clock source

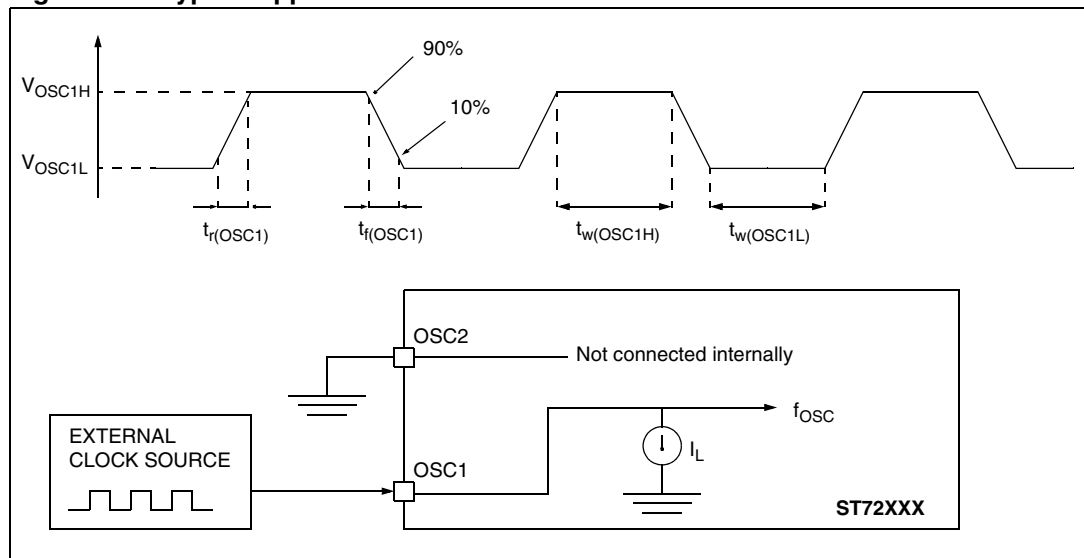

Table 97. Auto-wakeup from Halt oscillator (AWU) characteristics

Symbol	Parameter	Conditions	Min	Typ	Max	Unit
f _{AWU}	AWU oscillator frequency		50	125	250	kHz
t _{RCSRT}	AWU oscillator startup time				50	µs

13.6.1 Crystal and ceramic resonator oscillators

The ST7 internal clock can be supplied with four different Crystal/Ceramic resonator oscillators. All the information given in this paragraph is based on characterization results with specified typical external components. In the application, the resonator and the load capacitors have to be placed as close as possible to the oscillator pins in order to minimize output distortion and startup stabilization time. Refer to the crystal/ceramic resonator manufacturer for more details (frequency, package, accuracy, etc.).

Table 98. Crystal/ceramic resonator oscillator characteristics

Symbol	Parameter	Conditions	Min	Max	Unit
f _{OSC}	Oscillator frequency ⁽¹⁾		1	16	MHz
R _F	Feedback resistor ⁽²⁾		20	40	kΩ
C _{L1} C _{L2}	Recommended load capacitance versus equivalent serial resistance of the crystal or ceramic resonator (R _S) ⁽³⁾	See Table 99 below			pF
i ₂	OSC2 driving current	f _{OSC} = 2 MHz, C ₀ = 6 pF, CL1 = CL2 = 68 pF	426		µA
		f _{OSC} = 4 MHz, C ₀ = 6 pF, CL1 = CL2 = 68 pF	425		
		f _{OSC} = 8 MHz, C ₀ = 6 pF, CL1 = CL2 = 40 pF	456		
		f _{OSC} = 16 MHz, C ₀ = 7 pF, CL1 = CL2 = 20 pF	660		

1. The oscillator selection can be optimized in terms of supply current using an high quality resonator with small R_S value. Refer to crystal/ceramic resonator manufacturer for more details.
2. Data based on characterisation results, not tested in production. The relatively low value of the RF resistor, offers a good protection against issues resulting from use in a humid environment, due to the induced leakage and the bias condition change. However, it is recommended to take this point into account if the µC is used in tough humidity conditions.
3. For C_{L1} and C_{L2} it is recommended to use high-quality ceramic capacitors in the 5-pF to 25-pF range (typ.) designed for high-frequency applications and selected to match the requirements of the crystal or resonator. C_{L1} and C_{L2} are usually the same size. The crystal manufacturer typically specifies a load capacitance which is the series combination of C_{L1} and C_{L2}. PCB and MCU pin capacitance must be included when sizing C_{L1} and C_{L2} (10 pF can be used as a rough estimate of the combined pin and board capacitance).

Table 99. Recommended load capacitance vs. equivalent serial resistance of ceramic resonator

Supplier	f _{OSC} [MHz]	Typical ceramic resonators ⁽¹⁾		CL1 ⁽²⁾ [pF]	CL2 ⁽²⁾ [pF]	RF [Ω]	Rd [Ω]	Supply voltage range (V)	Temperature range (°C)
		Type ⁽³⁾	Reference						
Murata	2	SMD	CSTCC2M00G56Z-R0	(47)	(47)	Open	0	2.7 to 5.5	-40 °C to 85 °C
	4	SMD	CSTCR4M00G55Z-R0	(39)	(39)	Open	0		
		LEAD	CSTLS4M00G56Z-B0	(47)	(47)	Open	0		
	8	SMD	CSTCE8M00G52Z-R0	(10)	(10)	Open	0		
		LEAD	CSTLS8M00G53Z-B0	(15)	(15)	Open	0		
	16	SMD	CSTCE16M0V51Z-R0	(5)	(5)	Open	0	3.3 to 5.5	
LEAD		CSTLS16M0X53Z-B0	(15)	(15)	6.8 k	0	3.4 to 5.5		

1. Resonator characteristics given by the ceramic resonator manufacturer. For more information on these resonators, please consult Murata's web site.
2. () means load capacitor built in resonator.
3. SMD = [-R0: Plastic tape package (Ø =180mm), -B0: Bulk]
LEAD = [-B0: Bulk].

Figure 97. Typical application with a crystal or ceramic resonator

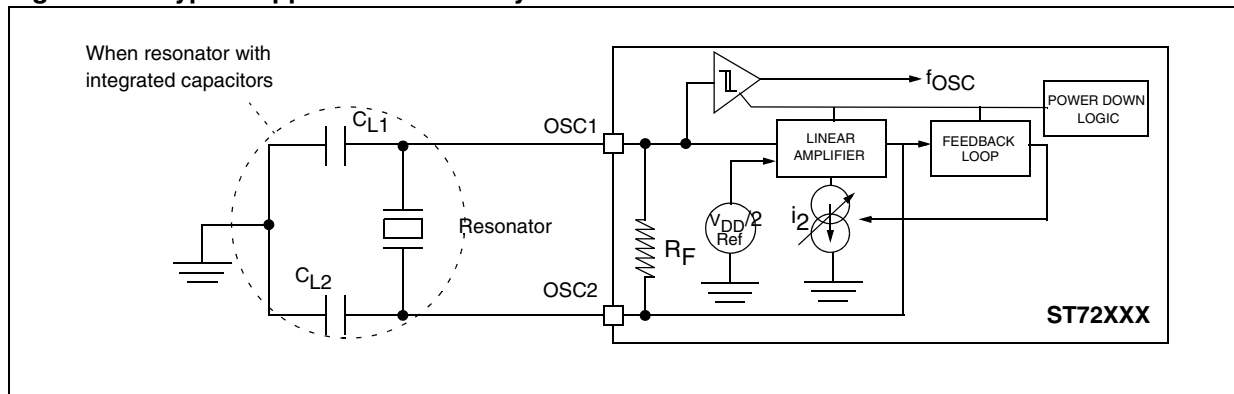

13.7 Memory characteristics

$T_A = -40^{\circ}\text{C}$ to 85°C , unless otherwise specified.

Table 100. RAM and hardware registers

Symbol	Parameter	Conditions	Min	Typ	Max	Unit
V_{RM}	Data retention mode ⁽¹⁾	Halt mode (or reset)	1.6			V

1. Minimum V_{DD} supply voltage without losing data stored in RAM (in Halt mode or under reset) or in hardware registers (only in Halt mode). Guaranteed by construction, not tested in production.

Table 101. Flash program memory

Symbol	Parameter	Conditions	Min	Typ	Max	Unit
V_{DD}	Operating voltage for Flash write/erase	Refer to operating range of V_{DD} with T_A , Table 87	2.7		5.5	V
t_{prog}	Programming time for 1~32 bytes ⁽¹⁾	$T_A = -40$ to $+85^{\circ}\text{C}$		5	10	ms
t_{RET}	Data retention ⁽²⁾	$T_A = +55^{\circ}\text{C}$ ⁽³⁾	20			years
N_{RW}	Write erase cycles	$T_A = +25^{\circ}\text{C}$	10,000 ⁽⁴⁾			cycles
I_{DD}	Supply current ⁽⁵⁾	Read / Write / Erase modes $f_{CPU} = 8$ MHz, $V_{DD} = 5.5\text{V}$			2.6	mA
		No Read/No Write Mode			100	μA
		Power down mode / Halt		0	0.1	μA

- Up to 32 bytes can be programmed at a time.
- Data based on reliability test results and monitored in production.
- The data retention time increases when the T_A decreases.
- Design target value pending full product characterization.
- Guaranteed by Design. Not tested in production.

Table 102. EEPROM data memory

Symbol	Parameter	Conditions	Min	Typ	Max	Unit
V_{DD}	Operating voltage for EEPROM write/erase	Refer to operating range of V_{DD} with T_A , Table 87: General operating conditions	2.7		5.5	V
t_{prog}	Programming time for 1~32 bytes	$T_A = -40$ to $+85^{\circ}\text{C}$		5	10	ms
t_{ret}	Data retention ⁽¹⁾	$T_A = +55^{\circ}\text{C}$ ⁽²⁾	20			years
N_{RW}	Write erase cycles	$T_A = +25^{\circ}\text{C}$	300,000 ⁽³⁾			cycles

- Data based on reliability test results and monitored in production.
- The data retention time increases when the T_A decreases.
- Design target value pending full product characterization.

13.8 EMC characteristics

Susceptibility tests are performed on a sample basis during product characterization.

13.8.1 Functional EMS (electromagnetic susceptibility)

Based on a simple running application on the product (toggling 2 LEDs through I/O ports), the product is stressed by two electromagnetic events until a failure occurs (indicated by the LEDs).

- **ESD:** Electro-Static Discharge (positive and negative) is applied on all pins of the device until a functional disturbance occurs. This test conforms with the IEC 1000-4-2 standard.
- **FTB:** A Burst of Fast Transient voltage (positive and negative) is applied to V_{DD} and V_{SS} through a 100 pF capacitor, until a functional disturbance occurs. This test conforms with the IEC 1000-4-4 standard.

A device reset allows normal operations to be resumed. The test results are given in the table below based on the EMS levels and classes defined in application note AN1709.

Designing hardened software to avoid noise problems

EMC characterization and optimization are performed at component level with a typical application environment and simplified MCU software. It should be noted that good EMC performance is highly dependent on the user application and the software in particular.

Therefore it is recommended that the user applies EMC software optimization and prequalification tests in relation with the EMC level requested for his application.

Software recommendations:

The software flowchart must include the management of runaway conditions such as:

- Corrupted program counter
- Unexpected reset
- Critical Data corruption (control registers...)

Prequalification trials:

Most of the common failures (unexpected reset and program counter corruption) can be reproduced by manually forcing a low state on the $\overline{\text{RESET}}$ pin or the Oscillator pins for 1 second.

To complete these trials, ESD stress can be applied directly on the device, over the range of specification values. When unexpected behavior is detected, the software can be hardened to prevent unrecoverable errors occurring (see application note AN1015).

Table 103. EMS test results

Symbol	Parameter	Conditions	Level/Class
V_{FESD}	Voltage limits to be applied on any I/O pin to induce a functional disturbance	$V_{DD} = 5 \text{ V}$, $T_A = +25 \text{ }^\circ\text{C}$, $f_{OSC} = 8 \text{ MHz}$ conforms to IEC 1000-4-2	TBD
V_{FFTB}	Fast transient voltage burst limits to be applied through 100 pF on V_{DD} and V_{SS} pins to induce a functional disturbance	$V_{DD} = 5 \text{ V}$, $T_A = +25 \text{ }^\circ\text{C}$, $f_{OSC} = 8 \text{ MHz}$ conforms to IEC 1000-4-4	TBD

13.8.2 EMI (electromagnetic interference)

Based on a simple application running on the product (toggling 2 LEDs through the I/O ports), the product is monitored in terms of emission. This emission test is in line with the norm SAE J 1752/3 which specifies the board and the loading of each pin.

Table 104. EMI emissions⁽¹⁾

Symbol	Parameter	Conditions	Monitored frequency band	Max vs. [f _{osc} /f _{cpu}]		Unit
				8/4 MHz	16/8 MHz	
S _{EMI}	Peak level	V _{DD} =5V, T _A =+25°C, SO20 package, conforming to SAE J 1752/3	0.1 MHz to 30 MHz	TBD	TBD	dBμV
			30 MHz to 130 MHz	TBD	TBD	
			130 MHz to 1 GHz	TBD	TBD	
			SAE EMI Level	TBD	TBD	-

1. Data based on characterization results, not tested in production.

13.8.3 Absolute maximum ratings (electrical sensitivity)

Based on two different tests (ESD and LU) using specific measurement methods, the product is stressed in order to determine its performance in terms of electrical sensitivity. For more details, refer to the application note AN1181.

Electrostatic discharge (ESD)

Electrostatic discharges (a positive then a negative pulse separated by 1 second) are applied to the pins of each sample according to each pin combination. The sample size depends on the number of supply pins in the device (3 parts*(n+1) supply pin). Human body model can be simulated. This test conforms to the JESD22-A114A/A115A standard.

Table 105. ESD absolute maximum ratings

Symbol	Ratings	Conditions	Maximum value ⁽¹⁾	Unit
V _{ESD(HBM)}	Electrostatic discharge voltage (human body model)	T _A = +25 °C	>2000	V

1. Data based on characterization results, not tested in production.

Static latch-up (LU)

Two complementary static tests are required on 6 parts to assess the latch-up performance.

- A supply overvoltage (applied to each power supply pin)
- A current injection (applied to each input, output and configurable I/O pin) performed on each sample.

This test conforms to the EIA/JESD 78 IC latch-up standard. For more details, refer to the application note AN1181.

Table 106. Electrical sensitivities

Symbol	Parameter	Conditions	Class
LU	Static latch-up class	$T_A = +25^\circ\text{C}$ $T_A = +85^\circ\text{C}$	A A

13.9 I/O port pin characteristics

Table 107. General characteristics (1)

Symbol	Parameter	Conditions	Min	Typ	Max	Unit
V_{IL}	Input low level voltage (4)		$V_{SS} - 0.3$		$0.3 \times V_{DD}$	V
V_{IH}	Input high level voltage (4)		$0.7 \times V_{DD}$		$V_{DD} + 0.3$	
V_{hys}	Schmitt trigger voltage hysteresis (4)			400		mV
I_L	Input leakage current	$V_{SS} \leq V_{IN} \leq V_{DD}$			± 1	μA
I_S	Static current consumption induced by each floating input pin (2)	Floating input mode		400		
R_{PU}	Weak pull-up equivalent resistor (3)	$V_{IN} = V_{SS}$	$V_{DD} = 5\text{V}$ $V_{DD} = 3\text{V}$	50 160	120 250	k Ω
C_{IO}	I/O pin capacitance			5		pF
$t_{f(IO)out}$	Output high to low level fall time (4)	$C_L = 50\text{ pF}$ Between 10% and 90%		25		ns
$t_{r(IO)out}$	Output low to high level rise time (4)			25		
$t_{w(IT)in}$	External interrupt pulse time (5)		1			t_{CPU}

1. Subject to general operating conditions for V_{DD} , f_{OSC} , and T_A unless otherwise specified.
2. Configuration not recommended, all unused pins must be kept at a fixed voltage: using the output mode of the I/O for example or an external pull-up or pull-down resistor (see [Figure 98](#)). Static peak current value taken at a fixed V_{IN} value, based on design simulation and technology characteristics, not tested in production. This value depends on V_{DD} and temperature values.
3. The R_{PU} pull-up equivalent resistor is based on a resistive transistor.
4. Data based on validation/design results.
5. To generate an external interrupt, a minimum pulse width has to be applied on an I/O port pin configured as an external interrupt source.

Figure 98. Two typical applications with unused I/O pin

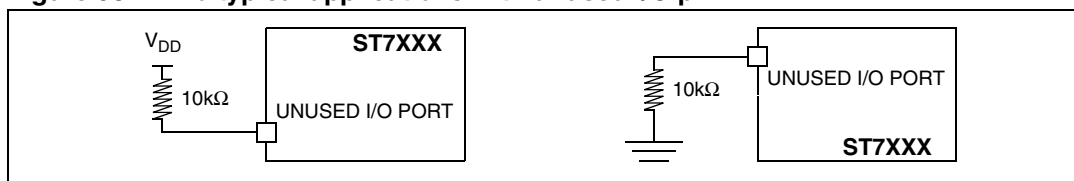

1. I/O can be left unconnected if it is configured as output (0 or 1) by the software. This has the advantage of greater EMC robustness and lower cost.

Caution: During normal operation the ICCCLK pin must be pulled-up, internally or externally (external pull-up of 10k mandatory in noisy environment). This is to avoid entering ICC mode unexpectedly during a reset.

Table 108. Output driving current ⁽¹⁾

Symbol	Parameter	Conditions	Min	Max	Unit
V _{OL} ⁽²⁾	Output low level voltage for a standard I/O pin when 8 pins are sunk at same time (see Figure 101)	I _{IO} = +5 mA		1.0	V
		I _{IO} = +2 mA		0.4	
	Output low level voltage for a high sink I/O pin when 4 pins are sunk at same time (see Figure 104)	I _{IO} = +20 mA		1.3	
		I _{IO} = +8 mA		0.75	
V _{OH} ⁽³⁾	Output high level voltage for an I/O pin when 4 pins are sourced at same time (see Figure 113)	I _{IO} = -5 mA	V _{DD} -1.5		
		I _{IO} = -2 mA	V _{DD} -0.8		
V _{OL} ⁽²⁾⁽⁴⁾	Output low level voltage for a standard I/O pin when 8 pins are sunk at same time (see Figure 100)	I _{IO} = +2 mA		0.7	
		I _{IO} = +8 mA		0.5	
V _{OH} ⁽³⁾⁽⁴⁾	Output high level voltage for an I/O pin when 4 pins are sourced at same time (Figure 111)	I _{IO} = -2 mA	V _{DD} -0.8		
V _{OL} ⁽²⁾⁽⁴⁾	Output low level voltage for a standard I/O pin when 8 pins are sunk at same time (see Figure 102)	I _{IO} = +2 mA		0.9	
		I _{IO} = +8 mA		0.6	
V _{OH} ⁽³⁾⁽⁴⁾	Output high level voltage for an I/O pin when 4 pins are sourced at same time (see Figure 110)	I _{IO} = -2 mA	V _{DD} -0.9		

1. Subject to general operating conditions for V_{DD}, f_{CPU}, and T_A unless otherwise specified.
2. The I_{IO} current sunk must always respect the absolute maximum rating specified in [Table 85: Current characteristics](#) and the sum of I_{IO} (I/O ports and control pins) must not exceed I_{VSS}.
3. The I_{IO} current sourced must always respect the absolute maximum rating specified in [Table 85: Current characteristics](#) and the sum of I_{IO} (I/O ports and control pins) must not exceed I_{VDD}.
4. Not tested in production, based on characterization results.

Figure 99. Typical V_{OL} at $V_{DD} = 2.4\text{ V}$ (std I/Os)

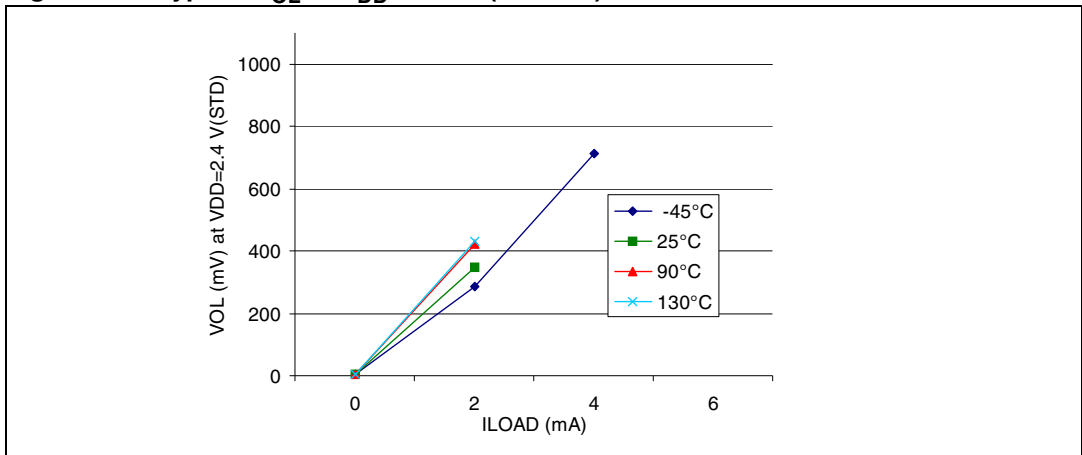

Figure 100. Typical V_{OL} at $V_{DD} = 3\text{ V}$ (std I/Os)

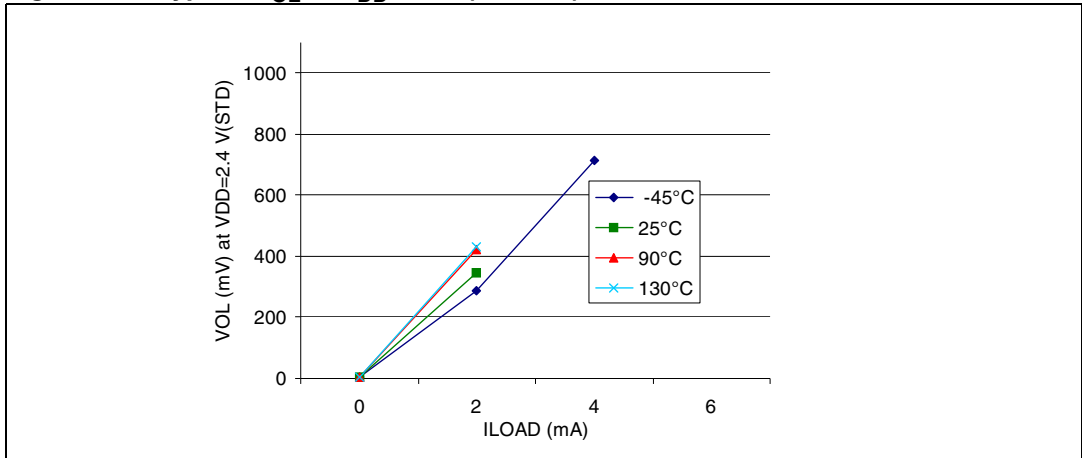

Figure 101. Typical V_{OL} at $V_{DD} = 5\text{ V}$ (std I/Os)

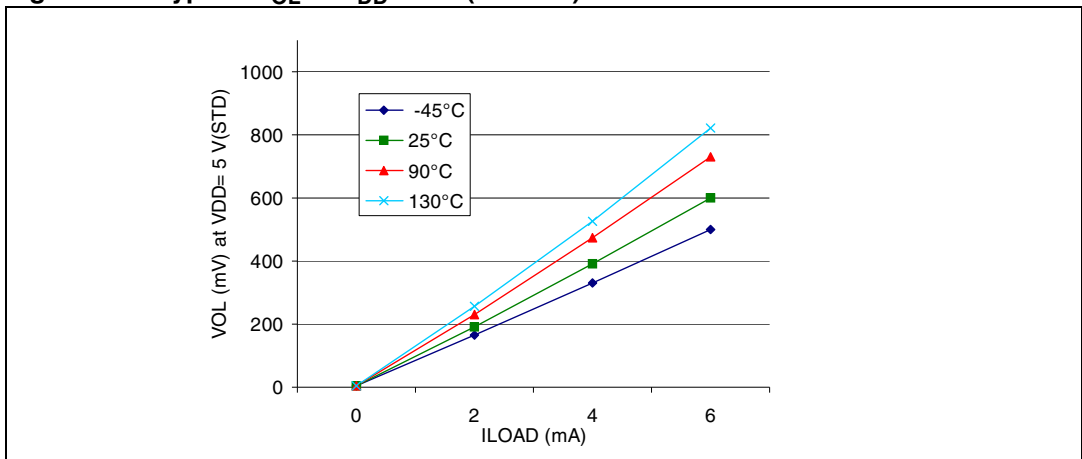

Figure 102. Typical V_{OL} at $V_{DD} = 2.4\text{ V}$ (high-sink I/Os)

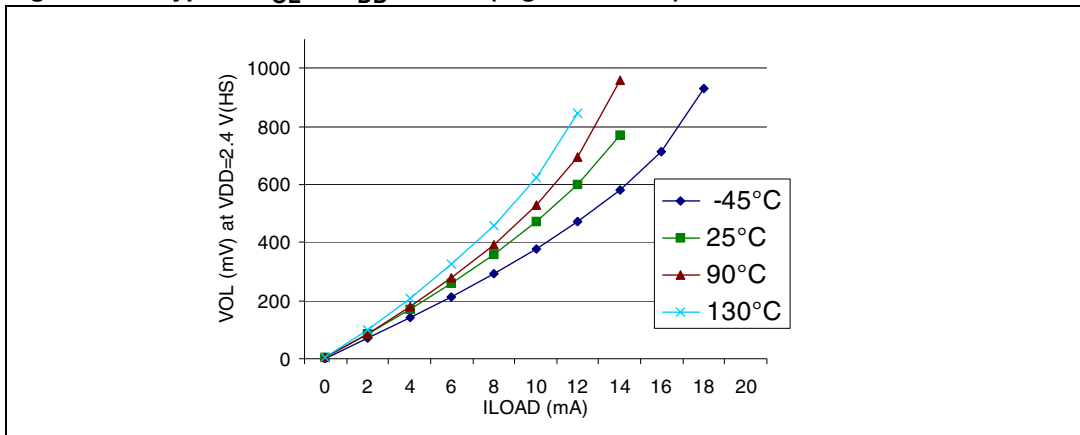

Figure 103. Typical V_{OL} at $V_{DD} = 3\text{ V}$ (high-sink I/Os)

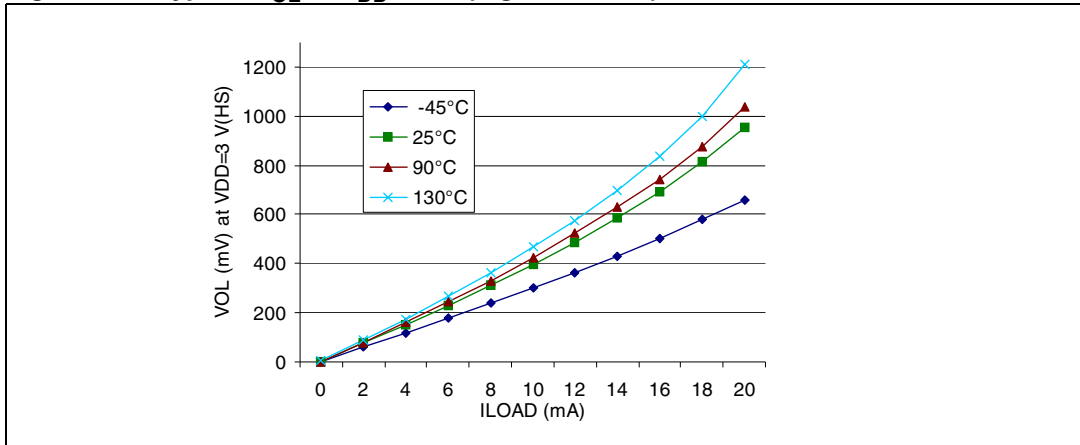

Figure 104. Typical V_{OL} at $V_{DD} = 5\text{ V}$ (high-sink I/Os)

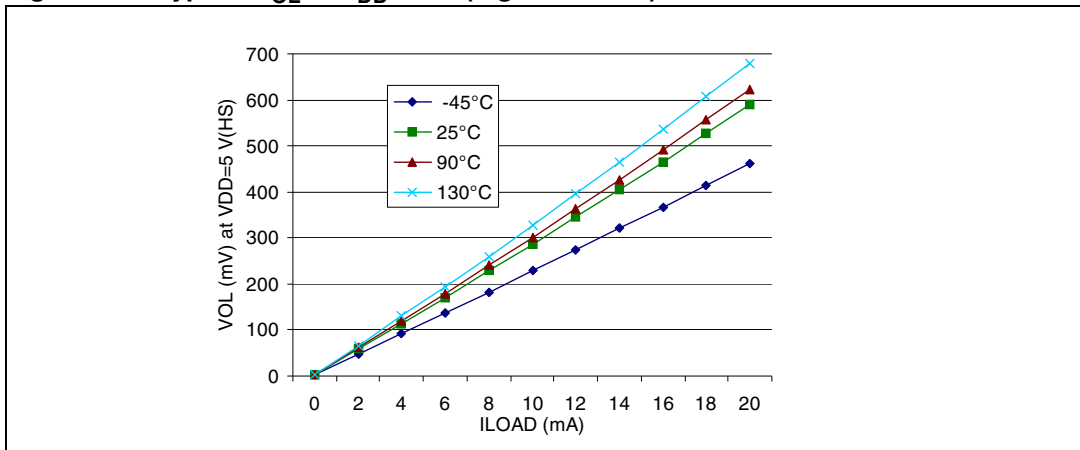

Figure 105. Typical V_{OL} vs. V_{DD} (std I/Os, 2 mA)

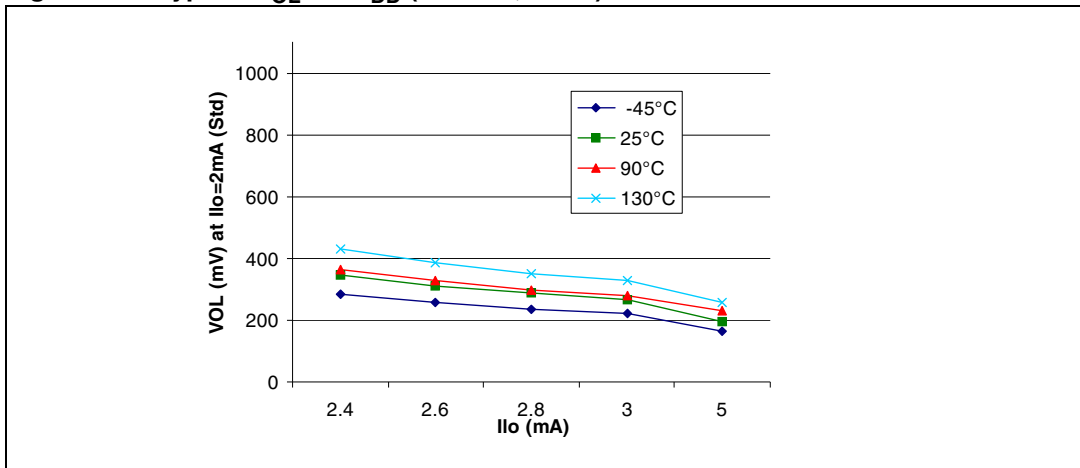

Figure 106. Typical V_{OL} vs. V_{DD} (std I/Os, 6 mA)

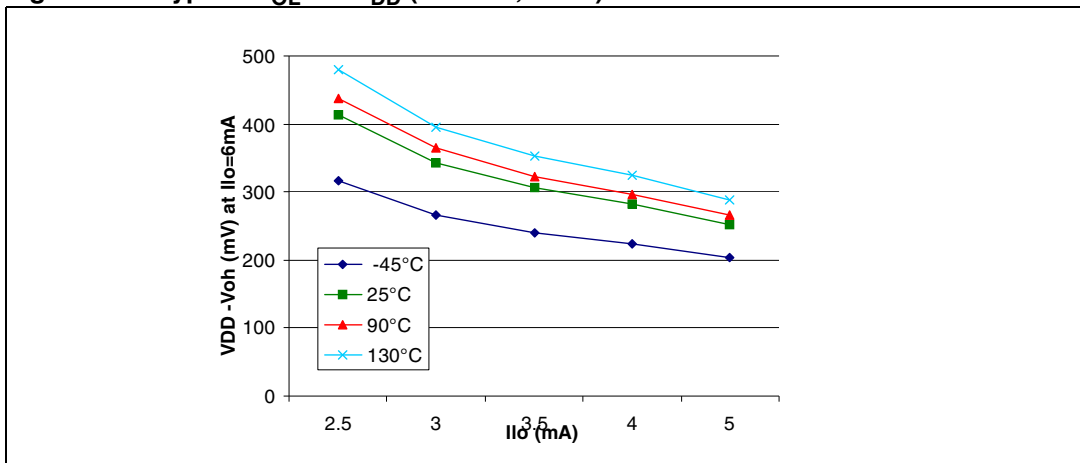

Figure 107. Typical V_{OL} vs. V_{DD} (HS I/Os, $I_{IO} = 8$ mA)

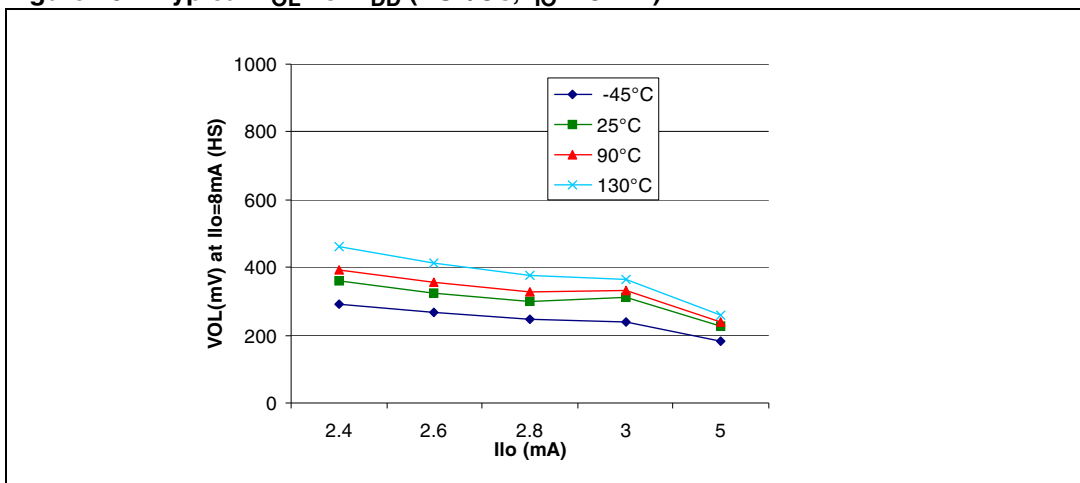

Figure 108. Typical V_{OL} vs. V_{DD} (HS I/Os, $I_{IO} = 2\text{ mA}$)

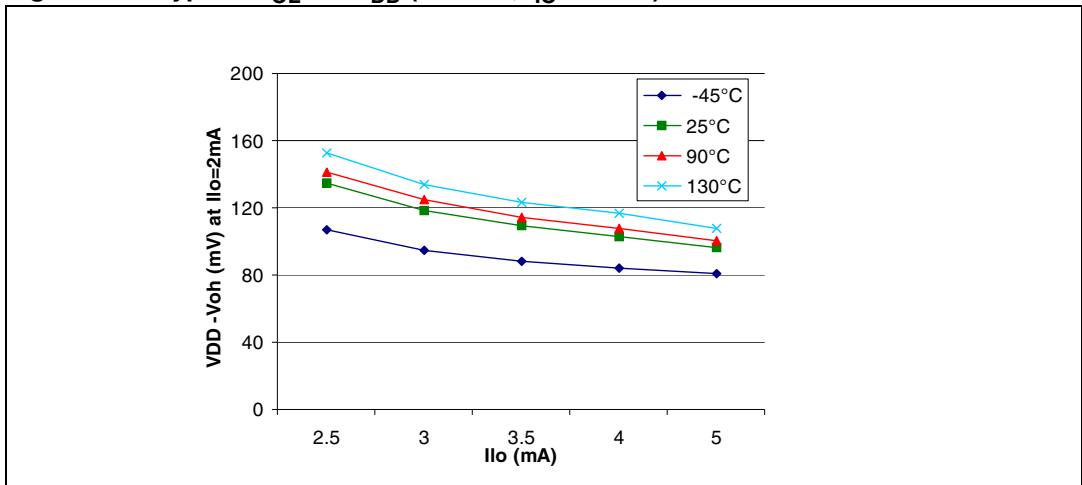

Figure 109. Typical V_{OL} vs. V_{DD} (HS I/Os, $I_{IO} = 12\text{ mA}$)

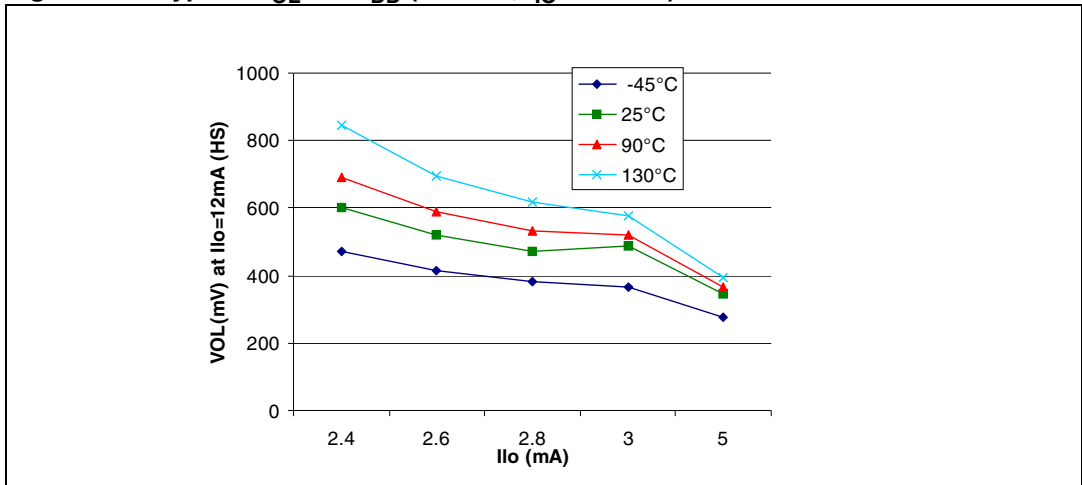

Figure 110. Typical $V_{DD} - v_{OH}$ at $V_{DD} = 2.4\text{ V}$ (std I/Os)

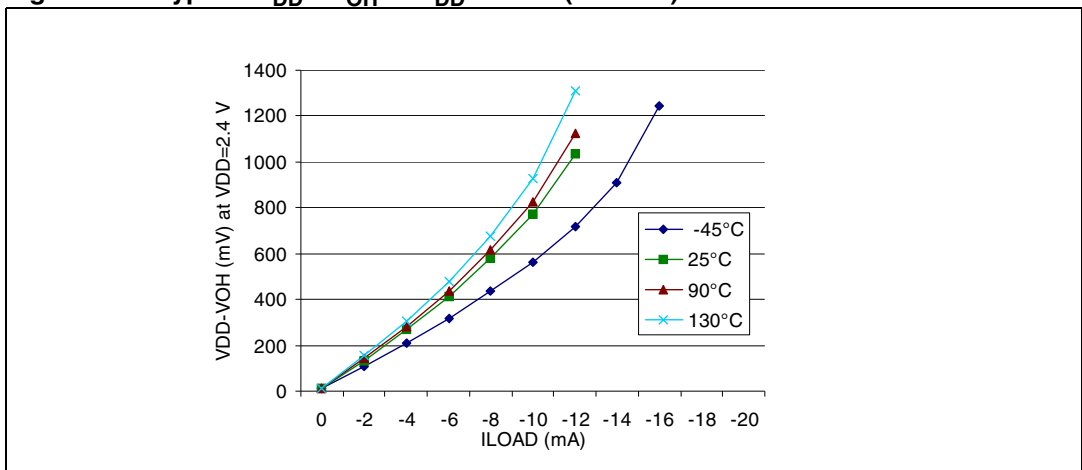

Figure 111. Typical $V_{DD} - V_{OH}$ at $V_{DD} = 3\text{ V}$ (std I/Os)

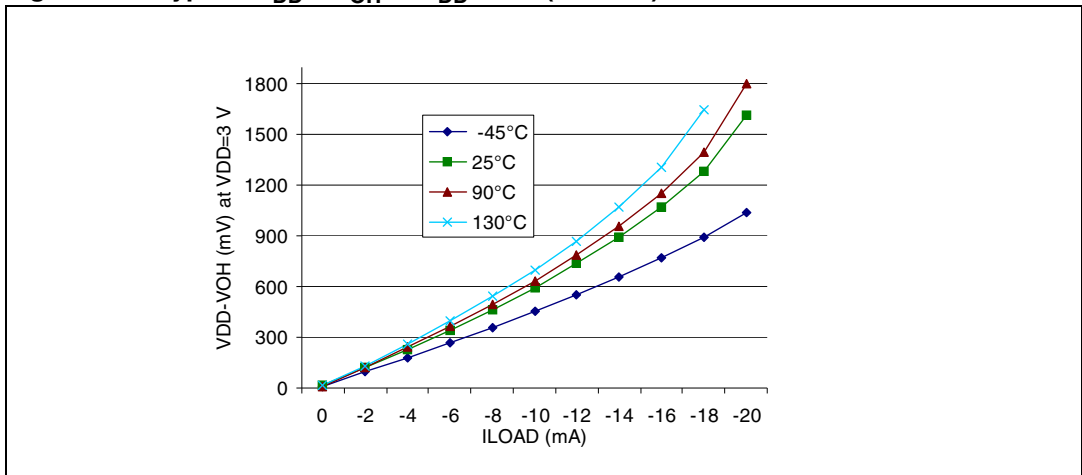

Figure 112. Typical $V_{DD} - V_{OH}$ at $V_{DD} = 4\text{ V}$ (std)

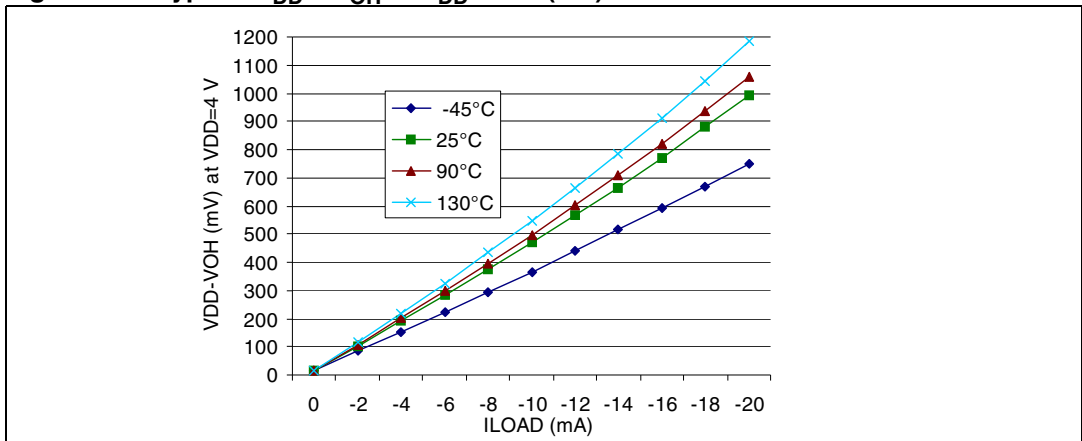

Figure 113. Typical $V_{DD} - V_{OH}$ at $V_{DD} = 5\text{ V}$ (std)

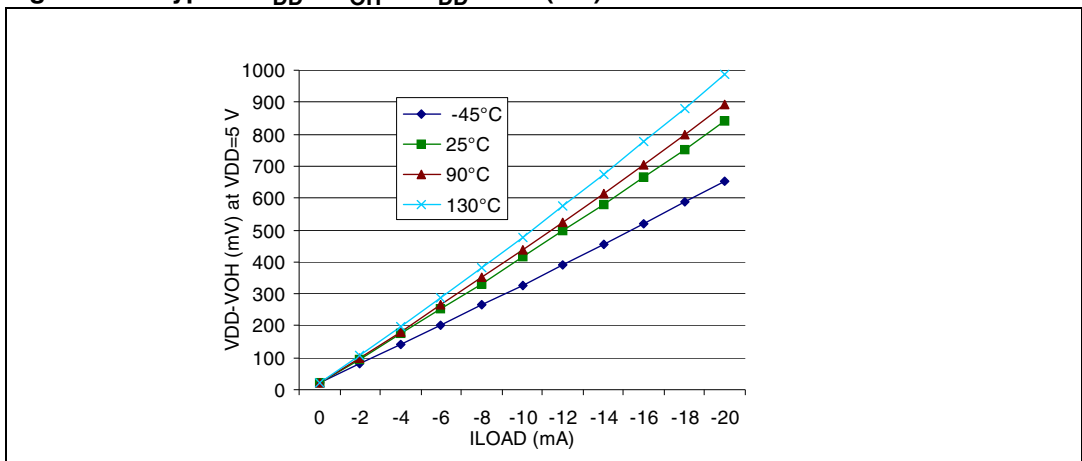
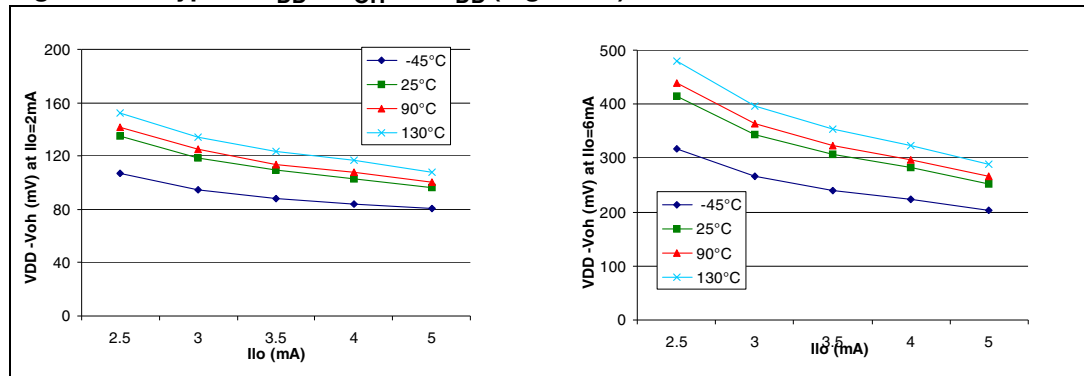

Figure 114. Typical $V_{DD} - V_{OH}$ vs. V_{DD} (high sink)



13.10 Control pin characteristics

13.10.1 Asynchronous $\overline{\text{RESET}}$ pin

$T_A = -40\text{ }^\circ\text{C}$ to $85\text{ }^\circ\text{C}$, unless otherwise specified.

Table 109. Asynchronous $\overline{\text{RESET}}$ pin characteristics

Symbol	Parameter	Conditions	Min	Typ	Max	Unit
V_{IL}	Input low level voltage		$V_{SS} - 0.3$		$0.3V_{DD}$	V
V_{IH}	Input high level voltage		$0.7V_{DD}$		$V_{DD} + 0.3$	
V_{hys}	Schmitt trigger voltage hysteresis ⁽¹⁾			2		V
V_{OL}	Output low level voltage ⁽²⁾	$V_{DD} = 5\text{ V}$ $I_{IO} = +5\text{ mA}$		0.5	1.0	V
		$V_{DD} = 5\text{ V}$ $I_{IO} = +2\text{ mA}$		0.2	0.4	
R_{ON}	Pull-up equivalent resistor ⁽³⁾⁽¹⁾	$V_{DD} = 5\text{ V}$	20	40	80	k Ω
		$V_{DD} = 3\text{ V}$	40	70	120	
$t_{w(RSTL)out}$	Generated reset pulse duration	Internal reset sources	14 ⁽¹⁾	32		μs
$t_{h(RSTL)in}$	External reset pulse hold time ⁽⁴⁾		12 ⁽¹⁾			μs
$t_{g(RSTL)in}$	Filtered glitch duration			200		ns

1. Data based on characterization results, not tested in production.
2. The I_{IO} current sunk must always respect the absolute maximum rating specified in [Table 85: Current characteristics](#) and the sum of I_{IO} (I/O ports and control pins) must not exceed I_{VSS} .
3. The R_{ON} pull-up equivalent resistor is based on a resistive transistor. Specified for voltages on $\overline{\text{RESET}}$ pin between V_{ILmax} and V_{DD} .
4. To guarantee the reset of the device, a minimum pulse has to be applied to the $\overline{\text{RESET}}$ pin. All short pulses applied on $\overline{\text{RESET}}$ pin with a duration below $t_{h(RSTL)in}$ can be ignored.

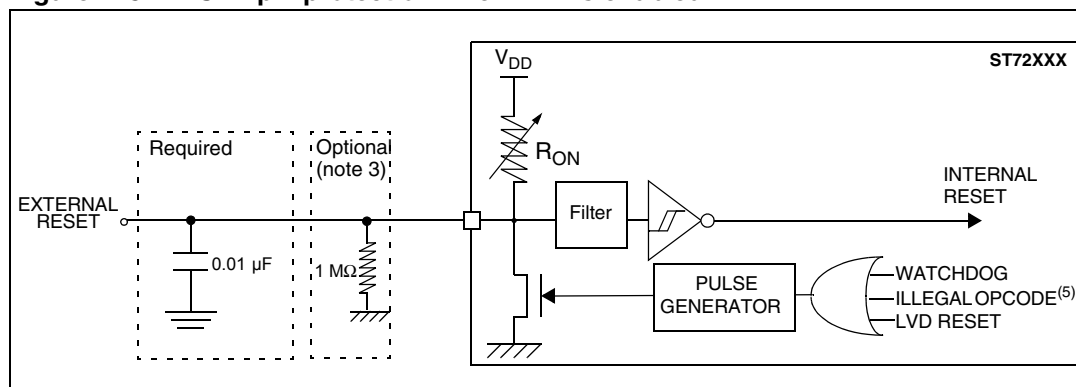
Figure 115. $\overline{\text{RESET}}$ pin protection when LVD is enabled⁽¹⁾⁽²⁾⁽³⁾⁽⁴⁾

- The reset network protects the device against parasitic resets.
 - The output of the external reset circuit must have an open-drain output to drive the ST7 reset pad. Otherwise the device can be damaged when the ST7 generates an internal reset (LVD or watchdog).
 - Whatever the reset source is (internal or external), the user must ensure that the level on the $\overline{\text{RESET}}$ pin can go below the V_{IL} max. level specified in Section 13.10.1. Otherwise the reset will not be taken into account internally.
 - Because the reset circuit is designed to allow the internal reset to be output in the $\overline{\text{RESET}}$ pin, the user must ensure that the current sunk on the $\overline{\text{RESET}}$ pin is less than the absolute maximum value specified for $I_{INJ}(\overline{\text{RESET}})$ in Table 85.
- When the LVD is enabled, it is recommended not to connect a pull-up resistor or capacitor. A 10nF pull-down capacitor is required to filter noise on the reset line.
- In case a capacitive power supply is used, it is recommended to connect a 1M Ω pull-down resistor to the $\overline{\text{RESET}}$ pin to discharge any residual voltage induced by the capacitive effect of the power supply (this will add 5 μ A to the power consumption of the MCU).
- Tips when using the LVD:
 - Check that all recommendations related to the reset circuit have been applied (see notes above)
 - Check that the power supply is properly decoupled (100nF + 10 μ F close to the MCU). Refer to AN1709 and AN2017. If this cannot be done, it is recommended to put a 100nF + 1M Ω pull-down on the $\overline{\text{RESET}}$ pin.
 - The capacitors connected on the $\overline{\text{RESET}}$ pin and also the power supply are key to avoid any startup marginality. In most cases, steps 1 and 2 above are sufficient for a robust solution. Otherwise: replace 10nF pull-down on the $\overline{\text{RESET}}$ pin with a 5 μ F to 20 μ F capacitor.”
- Please refer to Section 12.2.1: Illegal opcode reset for more details on illegal opcode reset conditions.

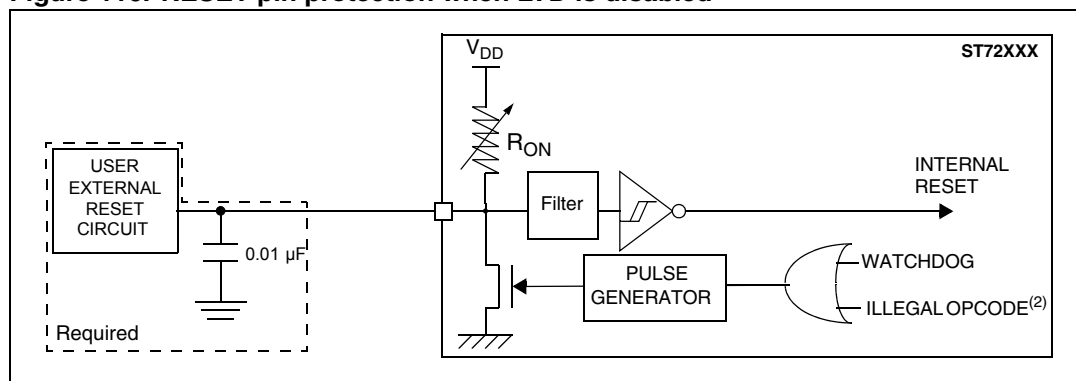
Figure 116. $\overline{\text{RESET}}$ pin protection when LVD is disabled⁽¹⁾

- The reset network protects the device against parasitic resets.
 - The output of the external reset circuit must have an open-drain output to drive the ST7 reset pad. Otherwise the device can be damaged when the ST7 generates an internal reset (LVD or watchdog).
 - Whatever the reset source is (internal or external), the user must ensure that the level on the $\overline{\text{RESET}}$ pin can go below the V_{IL} max. level specified in Section 13.10.1. Otherwise the reset will not be taken into account internally.
 - Because the reset circuit is designed to allow the internal reset to be output in the $\overline{\text{RESET}}$ pin, the user must ensure that the current sunk on the $\overline{\text{RESET}}$ pin is less than the absolute maximum value specified for $I_{INJ}(\overline{\text{RESET}})$ in Table 85.
- Please refer to Section 12.2.1: Illegal opcode reset for more details on illegal opcode reset conditions.

13.11 Communication interface characteristics

13.11.1 I²C and I²C3SNS interfaces

Subject to general operating conditions for V_{DD}, f_{OSC}, and T_A unless otherwise specified.

Refer to I/O port characteristics for more details on the input/output alternate function characteristics (SDAI and SCLI). The ST7 I²C and I2C3SNS interfaces meet the electrical and timing requirements of the Standard I²C communication protocol.

T_A = -40°C to 85°C, unless otherwise specified.

Table 110. I²C and I²C3SNS interfaces characteristics

Symbol	Parameter	Conditions	Min	Max	Unit
f _{SCL}	I ² C SCL frequency	f _{CPU} =4 MHz to 8 MHz ⁽¹⁾ , V _{DD} = 2.7 V to 5.5 V		400	kHz
f _{SCL3SNS}	I ² C3SNS SCL frequency ⁽²⁾			400	kHz

1. The I²C and I2C3SNS interfaces will not function below the minimum clock speed of 4 MHz.
2. Not tested in production within the whole operating range. Guaranteed by design/validation test results.

The following table gives the values to be written in the I2CCCR register to obtain the required I²C SCL line frequency.

Table 111. SCL frequency table (multimaster I²C interface) ⁽¹⁾

f _{SCL}	I2CCCR value							
	f _{CPU} = 4 MHz.				f _{CPU} = 8 MHz.			
	V _{DD} = 3.3 V		V _{DD} = 5 V		V _{DD} = 3.3 V		V _{DD} = 5 V	
	R _p =3.3kΩ	R _p =4.7kΩ	R _p =3.3kΩ	R _p =4.7kΩ	R _p =3.3kΩ	R _p =4.7kΩ	R _p =3.3kΩ	R _p =4.7kΩ
400	NA	NA	NA	NA	84h	84h	84h	84h
300	NA	NA	NA	NA	86h	86h	85h	87h
200	84h	84h	84h	84h	8Ah	8Ah	8Bh	8Ch
100	11h	10h	11h	11h	25h	24h	28h	28h
50	25h	24h	25h	26h	4Bh	4Ch	53h	54h
20	60h	5Fh	60h	62h	FFh	FFh	FFh	FFh

1. R_p = External pull-up resistance, f_{SCL} = I²C speed, NA = Not achievable.

Note: For speeds around 200 kHz, achieved speed can have ±5% tolerance; for other speed ranges, achieved speed can have ±2% tolerance. The above variations depend on the accuracy of the external components used.

13.12 10-bit ADC characteristics

T_A = -40 °C to 85 °C, unless otherwise specified

Table 112. ADC accuracy

Symbol	Parameter	Conditions ⁽¹⁾⁽²⁾	Typ	Max ⁽³⁾	Unit
E _T	Total unadjusted error	f _{CPU} = 8 MHz, f _{ADC} = 4 MHz R _{AIN} < 10kΩ V _{DD} = 2.7 V to 5.5 V	4	8	LSB
E _O	Offset error		-1	-2	
E _G	Gain Error		-2	-4	
E _D	Differential linearity error		3	6	

1. Data based on characterization results over the whole temperature range.
2. ADC accuracy vs. negative injection current: Injecting negative current on any of the analog input pins may reduce the accuracy of the conversion being performed on another analog input. The effect of negative injection current on robust pins is specified in [Section 13.10](#). Any positive injection current within the limits specified for I_{INJ(PIN)} and ΣI_{INJ(PIN)} in [Section 13.9](#) does not affect the ADC accuracy.
3. Data based on characterization results, monitored in production to guarantee 99.73% within ± max value from -40 °C to +125 °C (± 3σ distribution limits).

Figure 117. ADC accuracy characteristics

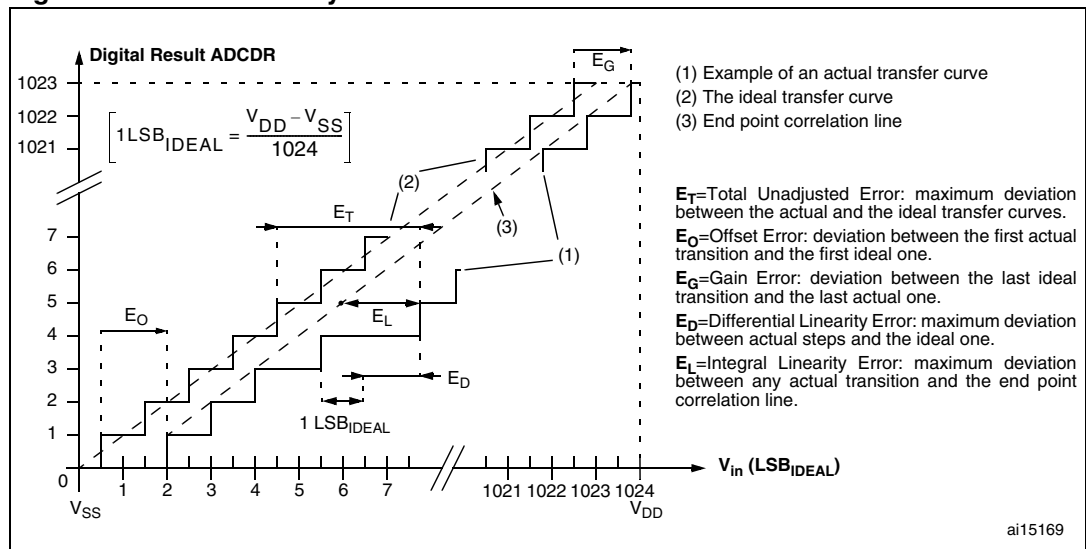

Subject to general operating condition for V_{DD} , f_{OSC} , and T_A unless otherwise specified.

Table 113. ADC characteristics

Symbol	Parameter	Conditions	Min	Typ ⁽¹⁾	Max	Unit
f_{ADC}	ADC clock frequency		0.4		4	MHz
V_{AIN}	Conversion voltage range ⁽²⁾		V_{SSA}		V_{DDA}	V
R_{AIN}	External input resistor				10 ⁽³⁾	k Ω
C_{ADC}	Internal sample and hold capacitor			6		pF
t_{STAB}	Stabilization time after ADC enable		0 ⁽⁴⁾			μ s
t_{ADC}	Conversion time (Sample+Hold)	$f_{CPU} = 8$ MHz, $f_{ADC} = 4$ MHz	3.5			
	– Sample capacitor loading time – Hold conversion time		4 10			1/ f_{ADC}
I_{ADC}	Analog Part			1		mA
	Digital Part			0.2		

1. Unless otherwise specified, typical data are based on $T_A = 25$ °C and $V_{DD} - V_{SS} = 5$ V. They are given only as design guidelines and are not tested.
2. When V_{DDA} and V_{SSA} pins are not available on the pinout, the ADC refers to V_{DD} and V_{SS} .
3. Any added external serial resistor will downgrade the ADC accuracy (especially for resistance greater than 10 k Ω). Data based on characterization results, not tested in production.
4. The stabilization time of the AD converter is masked by the first t_{LOAD} . The first conversion after the enable is then always valid.

Figure 118. Typical A/D converter application

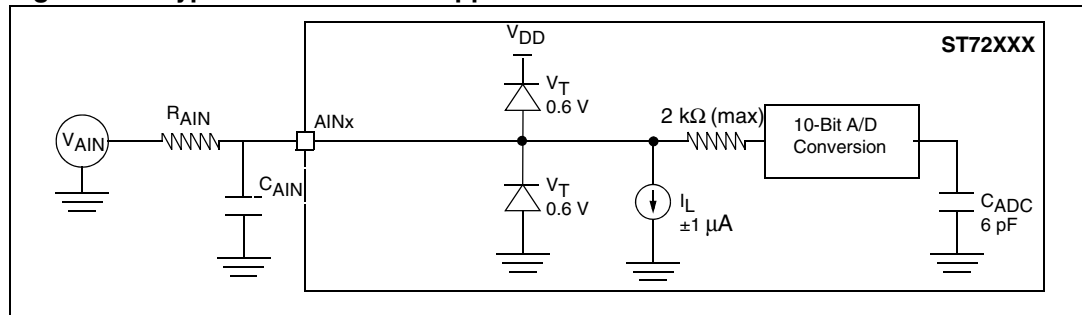

- Note:
- 1 $C_{PARASITIC}$ represents the capacitance of the PCB (dependent on soldering and PCB layout quality) plus the pad capacitance (3 pF). A high $C_{PARASITIC}$ value will downgrade conversion accuracy. To remedy this, f_{ADC} should be reduced.
 - 2 This graph shows that depending on the input signal variation (f_{AIN}), C_{AIN} can be increased for stabilization time and decreased to allow the use of a larger serial resistor (R_{AIN}).

14 Package characteristics

14.1 ECOPACK

In order to meet environmental requirements, ST offers these devices in different grades of ECOPACK® packages, depending on their level of environmental compliance. ECOPACK® specifications, grade definitions and product status are available at: www.st.com. ECOPACK® is an ST trademark.

14.2 Package mechanical data

Figure 119. 32-pin low profile quad flat package (7 x 7 mm) outline

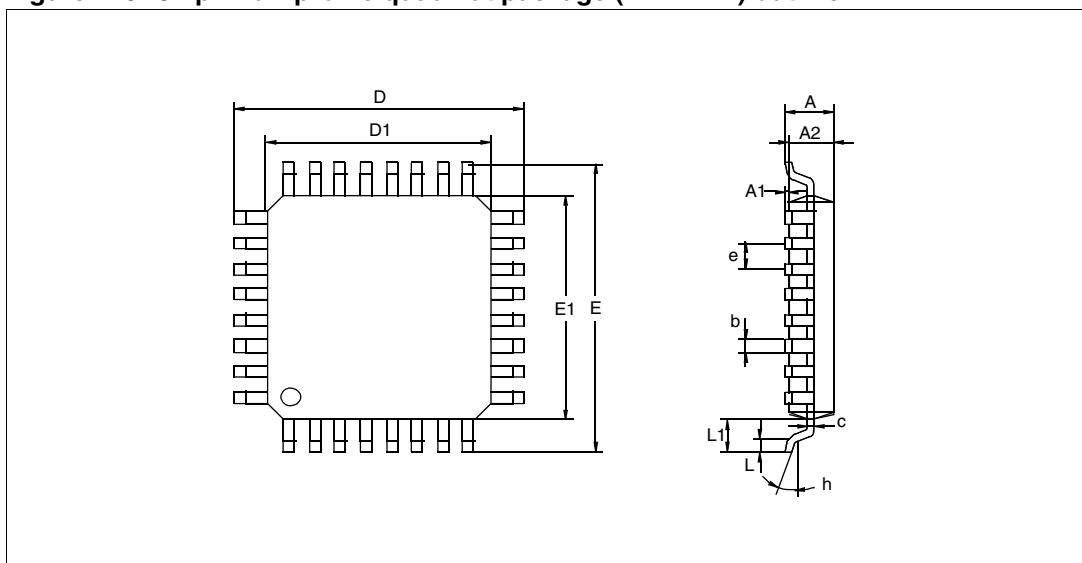

1. Drawing is not to scale.

Table 114. 32-pin low profile quad flat package (7 x 7 mm) mechanical data

Dim.	mm			inches ⁽¹⁾		
	Min	Typ	Max	Min	Typ	Max
A			1.60			0.0630
A1	0.05		0.15	0.0020		0.0059
A2	1.35	1.40	1.45	0.0531	0.0551	0.0571
b	0.30	0.37	0.45	0.0118	0.0146	0.0177
C	0.09		0.20	0.0035		0.0079
D		9.00			0.3543	
D1		7.00			0.2756	
E		9.00			0.3543	
E1		7.00			0.2756	
e		0.80			0.0315	
θ	0°	3.5°	7°	0°	3.5°	7°
L	0.45	0.60	0.75	0.0177	0.0236	0.0295
L1		1.00			0.0394	
N (number of pins)	32					

1. Values in inches are converted from mm and rounded to 4 decimal digits.

Figure 120. 40-lead very thin fine pitch quad flat no-lead package outline

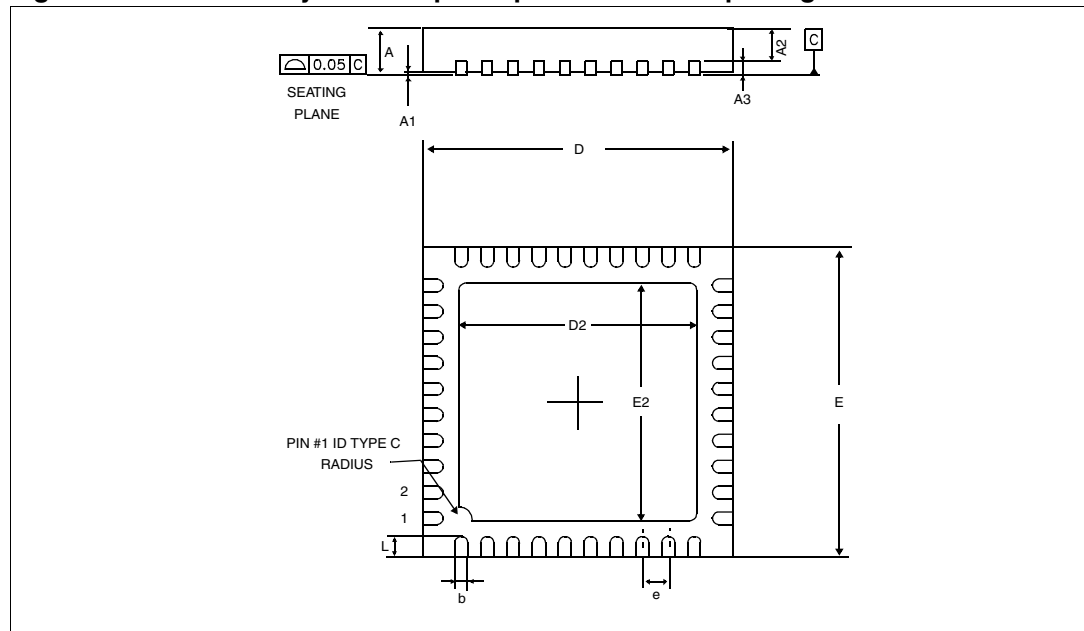

1. Drawing is not to scale.

Table 115. 40-lead very thin fine pitch quad flat no-lead package mechanical data

Dim.	mm			inches ⁽¹⁾		
	Min	Typ	Max	Min	Typ	Max
A	0.80	0.90	1.00	0.0315	0.0354	0.0394
A1		0.02	0.05		0.0008	0.0020
A2		0.65	1.00		0.0256	0.0394
A3		0.20			0.0079	
b	0.18	0.25	0.30	0.0071	0.0098	0.0118
D	5.85	6.00	6.15	0.2303	0.2362	0.2421
D2	2.75	2.9	3.05	0.1083	0.1142	0.1201
E	5.85	6	6.15	0.2303	0.2362	0.2421
E2	2.75	2.9	3.05	0.1083	0.1142	0.1201
e		0.50			0.0197	
L	0.30	0.40	0.50	0.0118	0.0157	0.0197
N	Number of pins					
	40					

1. Values in inches are converted from mm and rounded to 4 decimal digits.

Figure 121. 44-pin low profile quad flat package outline

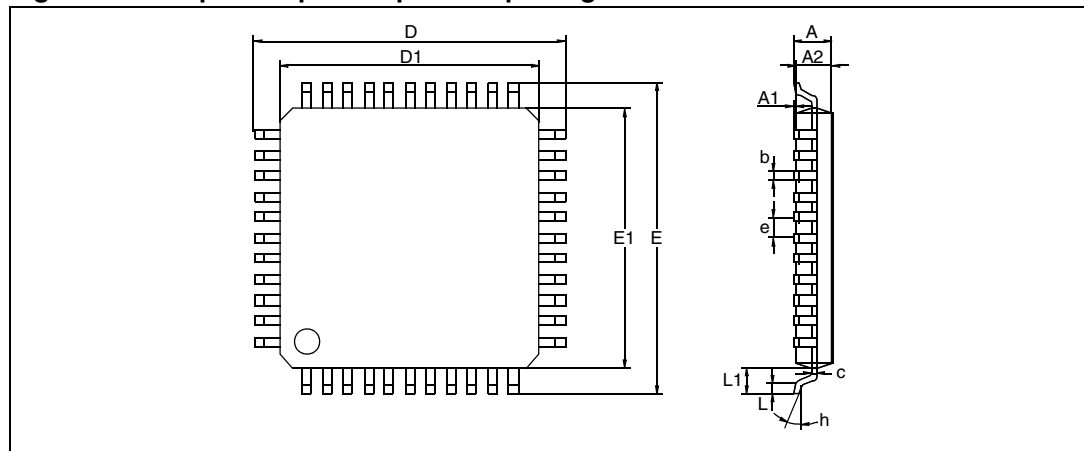

1. Drawing is not to scale.

Table 116. 44-pin low profile quad flat package mechanical data

Dim.	mm			inches ⁽¹⁾		
	Min	Typ	Max	Min	Typ	Max
A			1.60			0.0630
A1	0.05		0.15	0.0020		0.0059
A2	1.35	1.40	1.45	0.0531	0.0551	0.0571
b	0.30	0.37	0.45	0.0118	0.0146	0.0177
C	0.09		0.20	0.0035		0.0079
D		12.00			0.4724	
D1		10.00			0.3937	
E		12.00			0.4724	
E1		10.00			0.3937	
e		0.80			0.0315	
θ	0°	3.5°	7°	0°	3.5°	7°
L	0.45	0.60	0.75	0.0177	0.0236	0.0295
L1		1.00			0.0394	
N	Number of pins					
	44					

1. Values in inches are converted from mm and rounded to 4 decimal digits.

Figure 122. 48-pin low profile quad flat package outline

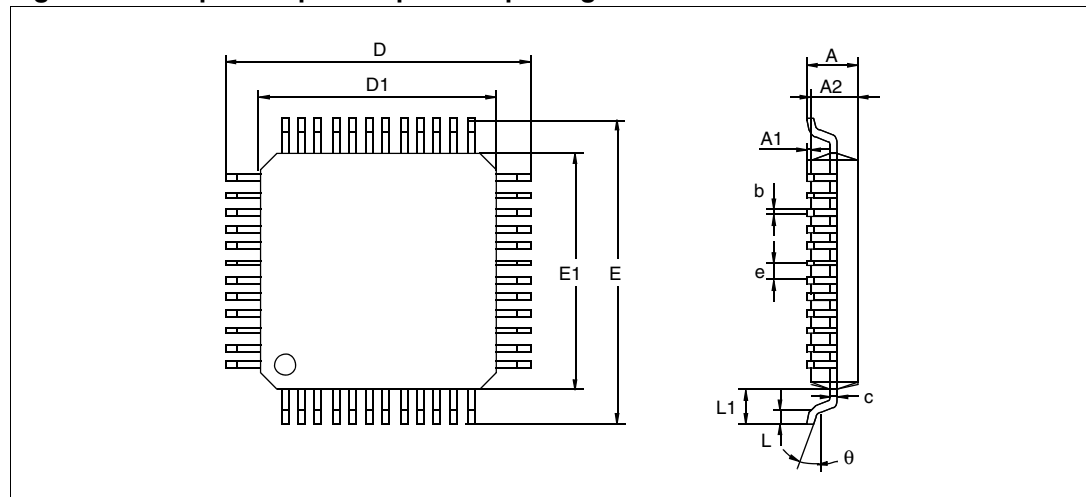

1. Drawing is not to scale.

Table 117. 48-pin low profile quad flat package mechanical data

Dim.	mm			inches ⁽¹⁾		
	Min	Typ	Max	Min	Typ	Max
A			1.60			0.0630
A1	0.05		0.15	0.0020		0.0059
A2	1.35	1.40	1.45	0.0531	0.0551	0.0571
b	0.17	0.22	0.27	0.0067	0.0087	0.0106
C	0.09		0.20	0.0035		0.0079
D		9.00			0.3543	
D1		7.00			0.2756	
E		9.00			0.3543	
E1		7.00			0.2756	
e		0.50			0.0197	
θ	0°	3.5°	7°	0°	3.5°	7°
L	0.45	0.60	0.75	0.0177	0.0236	0.0295
L1		1.00			0.0394	
N	Number of pins					
	48					

1. Values in inches are converted from mm and rounded to 4 decimal digits.

Table 118. Thermal characteristics

Symbol	Ratings	Value ⁽¹⁾	Unit	
R _{thJA}	Package thermal resistance (junction to ambient)	LQFP32	60	°C/W
		LQFP44	54	
		LQFP48	73	
T _{Jmax}	Maximum junction temperature ⁽²⁾	150	°C	
P _{Dmax}	Power dissipation ⁽³⁾	LQFP32	415	mW
		LQFP44	460	
		LQFP48	340	

1. Values given for a 4-layer board. P_{Dmax} computed for T_A = 125 °C.

2. The maximum chip-junction temperature is based on technology characteristics.

3. The maximum power dissipation is obtained from the formula $P_D = (T_J - T_A) / R_{thJA}$.
The power dissipation of an application can be defined by the user with the formula: $P_D = P_{INT} + P_{PORT}$
where P_{INT} is the chip internal power (I_{DD} × V_{DD}) and P_{PORT} is the port power dissipation depending on the ports used in the application.

15 Device configuration and ordering information

Each device is available for production in user programmable versions (Flash).

ST72F34x Flash devices are shipped to customers with a default content (FFh). This implies that Flash devices have to be configured by the customer using the Option Bytes.

15.1 Option bytes

The four option bytes allow the hardware configuration of the microcontroller to be selected.

The option bytes can be accessed only in programming mode (for example using a standard ST7 programming tool).

15.1.1 Option byte 0

OPT7 = **WDG Halt** *Watchdog Reset on Halt*

This option bit determines if a reset is generated when entering Halt mode while the Watchdog is active.

0: No Reset generation when entering Halt mode

1: Reset generation when entering Halt mode

OPT6 = **WDG SW** *Hardware or Software Watchdog*

This option bit selects the watchdog type.

0: Hardware (watchdog always enabled)

1: Software (watchdog to be enabled by software)

OPT5:4 = **LVD[1:0]** *Low voltage detection selection*

These option bits enable the LVD block with a selected threshold as shown in [Table 119](#).

Table 119. LVD threshold configuration

Configuration	LVD1	LVD0
LVD Off	1	1
Highest voltage threshold (~4.1V)	1	0
Medium voltage threshold (~3.5V)	0	1
Lowest voltage threshold (~2.8V)	0	0

OPT3:2 = **SEC[1:0]** *Sector 0 size definition*

These option bits indicate the size of sector 0 according to the following table.

Table 120. Size of sector 0

Sector 0 size	SEC1	SEC0
0.5k	0	0
1k	0	1

Table 120. Size of sector 0

Sector 0 size	SEC1	SEC0
2k	1	0
4k	1	1

OPT1 = FMP_R *Read-out protection*

Readout protection, when selected provides a protection against program memory content extraction and against write access to Flash memory. Erasing the option bytes when the FMP_R option is selected will cause the whole memory to be erased first and the device can be reprogrammed. Refer to the ST7 Flash Programming Reference Manual and [Section 4.5](#) for more details.

- 0: Read-out protection off
- 1: Read-out protection on

OPT0 = FMP_W *Flash write protection*

This option indicates if the Flash program memory is write protected.

Warning: When this option is selected, the program memory (and the option bit itself) can never be erased or programmed again.

- 0: Write protection off
- 1: Write protection on

		Option byte 0								Option byte 1							
		7	6	5	4	3	2	1	0	7	6	5	4	3	2	1	0
		WDG HALT	WDG SW	LVD1	LVD0	SEC1	SEC0	FMPR	FMPW	RSTC	OSCRANGE _{2:0}			OSC	DIV2EN	PLL x4x8	PLL OFF
Default value		1	1	1	1	1	1	0	0	1	1	1	1	0	1	1	1

15.1.2 Option byte 1

OPT7 = RSTC *reset clock cycle selection*

This option bit selects the number of CPU cycles inserted during the reset phase and when exiting Halt mode. For resonator oscillators, it is advised to select 4096 due to the long crystal stabilization time.

- 0: Reset phase with 4096 CPU cycles
- 1: Reset phase with 256 CPU cycles

OPT6:4 = OSCRANGE[2:0] *Oscillator range*

When the internal RC oscillator is not selected (Option OSC=1), these option bits select the range of the resonator oscillator current source or the external clock source.

Table 121. Selection of the resonator oscillator range

			OSCRANGE		
			2	1	0
Typical frequency range with Resonator	LP	1~2 MHz	0	0	0
	MP	2~4 MHz	0	0	1
	MS	4~8 MHz	0	1	0
	HS	8~16 MHz	0	1	1
Reserved			1	0	0
External clock			1	0	1
			1	1	0
			1	1	1

OPT3 = **OSC RC Oscillator selection**

- 0: RC oscillator on
- 1: RC oscillator off

OPT2 = **DIV2EN PLL Divide by 2 enable**

- 0: PLL division by 2 enabled
- 1: PLL division by 2 disabled

Note: **DIV2EN must be kept disabled when PLLx4 is enabled.**

OPT1 = **PLLx4x8 PLL Factor selection**

- 0: PLLx4
- 1: PLLx8

OPT0 = **PLLOFF PLL disable**

- 0: PLL enabled
- 1: PLL disabled (by-passed)

These option bits must be configured as described in [Table 122](#) depending on the voltage range and the expected CPU frequency.

Table 122. List of valid option combinations

Target ratio	V _{DD}	Option bits		
		DIV2 EN	PLL OFF	PLL x4x8
x4 ⁽¹⁾	2.7 V - 3.65 V	x	0	0
x4	3.3 V - 5.5 V	0	0	1
x8		1	0	1

1. For a target ratio of x4 between 3.3V - 3.65V, this is the recommended configuration.

15.1.3 Option byte 2

Note: **OPT7:0 = Reserved. Must be kept at 1.**

15.1.4 Option byte 3

OPT7:6 = **PKG1:0** *Package selection*

These option bits select the package.

Table 123. Package selection

Version	Selected package	PKG 1	PKG 0
K	LQFP32	0	0
S	LQFP44	0	1
C	LQFP48	1	x

OPT5 = **I2C3S** *I2C3SNS selection*

0: I2C3SNS selected

1: I2C3SNS not selected

OPT4:0 = Reserved. Must be kept at 1.

Table 124. Option byte default values

	Option byte 2								Option byte 3							
	7	6	5	4	3	2	1	0	7	6	5	4	3	2	1	0
	Reserved								PKG1	PKG0	I2C3S	Reserved				
Default value	1	1	1	1	1	1	1	1	x	x	x	1	1	1	1	1

15.2 Device ordering information

Figure 123. ST7234x ordering information scheme

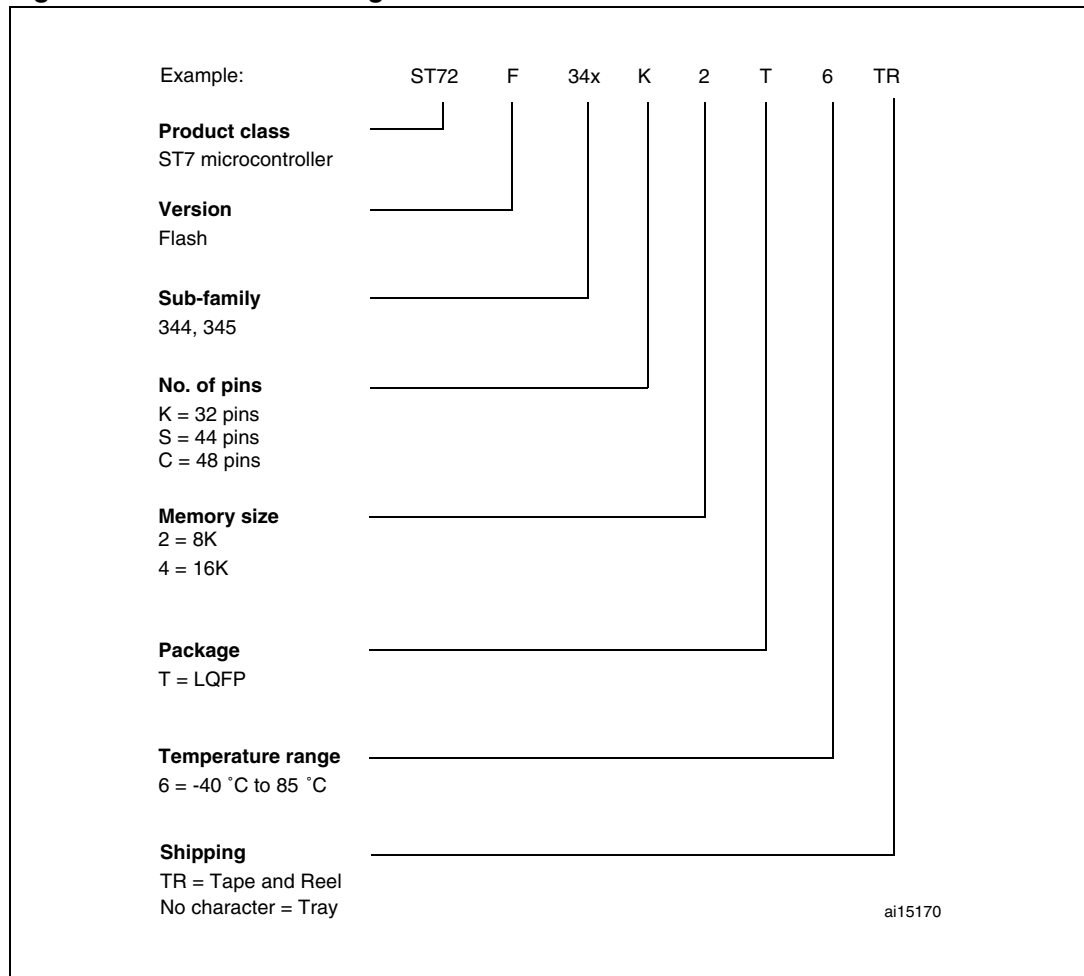

For a list of available options (e.g. memory size, package) and orderable part numbers or for further information on any aspect of this device, please contact the nearest ST sales office.

15.3 Development tools

Development tools for the ST7 microcontrollers include a complete range of hardware systems and software tools from STMicroelectronics and third-party tool suppliers. The range of tools includes solutions to help you evaluate microcontroller peripherals, develop and debug your application, and program your microcontrollers.

15.3.1 Starter kits

ST offers complete, affordable **starter kits**. Starter kits are complete, affordable hardware/software tool packages that include features and samples to help you quickly start developing your application.

15.3.2 Development and debugging tools

Application development for ST7 is supported by fully optimizing **C Compilers** and the **ST7 Assembler-Linker** toolchain, which are all seamlessly integrated in the ST7 integrated development environments in order to facilitate the debugging and fine-tuning of your application. The Cosmic C Compiler is available in a free version that outputs up to 16 KBytes of code.

The range of hardware tools includes full-featured **ST7-EMU3 series emulators** and the low-cost **RLink** in-circuit debugger/programmer. These tools are supported by the **ST7 Toolset** from STMicroelectronics, which includes the STVD7 integrated development environment (IDE) with high-level language debugger, editor, project manager and integrated programming interface.

15.3.3 Programming tools

During the development cycle, the **ST7-EMU3 series emulators** and the **RLink** provide in-circuit programming capability for programming the Flash microcontroller on your application board.

ST also provides a low-cost dedicated in-circuit programmer, the **ST7-STICK**, as well as **ST7 Socket Boards** which provide all the sockets required for programming any of the devices in a specific ST7 sub-family on a platform that can be used with any tool with in-circuit programming capability for ST7.

For production programming of ST7 devices, ST's third-party tool partners also provide a complete range of gang and automated programming solutions, which are ready to integrate into your production environment.

15.3.4 Order codes for ST72F34x development tools

Table 125. Development tool order codes

MCU	Starter kit	Emulator	Programming tool	
			In-circuit debugger/ programmer	Dedicated programmer
ST72F344 ST72F345	ST72F34x- SK/RAIS ⁽¹⁾	ST7MDT40-EMU3 ⁽²⁾	STX-RLINK ⁽³⁾ ST7-STICK ⁽⁴⁾⁽⁵⁾	ST7SB20J/xx ⁽⁴⁾⁽⁶⁾ ST7SB40-QP48/xx ⁽⁴⁾⁽⁷⁾

1. USB connection to PC
2. ST7MDT40-EMU3 order code is discontinued
3. RLink with ST7 tool set
4. Add suffix /EU, /UK or /US for the power supply for your region
5. Parallel port connection to PC
6. Only available for LQFP32 and LQFP44 packages
7. Only available for LQFP48 package

For additional ordering codes for spare parts and accessories, refer to the online product selector at www.st.com/mcu.

16 Known limitations

16.1 External interrupt missed

To avoid any risk if generating a parasitic interrupt, the edge detector is automatically disabled for one clock cycle during an access to either DDR and OR. Any input signal edge during this period will not be detected and will not generate an interrupt.

This case can typically occur if the application refreshes the port configuration registers at intervals during runtime.

16.1.1 Workaround

The workaround is based on software checking the level on the interrupt pin before and after writing to the PxOR or PxDDR registers. If there is a level change (depending on the sensitivity programmed for this pin), the interrupt routine is invoked using the call instruction with three extra PUSH instructions before executing the interrupt routine (this is to make the call compatible with the IRET instruction at the end of the interrupt service routine).

But detection of the level change does not make sure that edge occurs during the critical 1 cycle duration and the interrupt has been missed. This may lead to occurrence of same interrupt twice (one hardware and another with software call).

To avoid this, a semaphore is set to '1' before checking the level change. The semaphore is changed to level '0' inside the interrupt routine. When a level change is detected, the semaphore status is checked and if it is '1' this means that the last interrupt has been missed. In this case, the interrupt routine is invoked with the call instruction.

There is another possible case i.e. if writing to PxOR or PxDDR is done with global interrupts disabled (interrupt mask bit set). In this case, the semaphore is changed to '1' when the level change is detected. Detecting a missed interrupt is done after the global interrupts are enabled (interrupt mask bit reset) and by checking the status of the semaphore. If it is '1' this means that the last interrupt was missed and the interrupt routine is invoked with the call instruction.

To implement the workaround, the following software sequence is to be followed for writing into the PxOR/PxDDR registers. The example is for Port PF1 with falling edge interrupt sensitivity. The software sequence is given for both cases (global interrupt disabled/enabled).

Case 1: Writing to PxOR or PxDDR with global interrupts enabled:

```
LD A,#01
LD sema,A; set the semaphore to '1'
LD A,PFDR
AND A,#02
LD X,A; store the level before writing to PxOR/PxDDR
LD A,#$90
LD PFDDR,A; Write to PFDDR
LD A,#$ff
LD PFOR,A; Write to PFOR
LD A,PFDR
AND A,#02
```

```

LD Y,A; store the level after writing to PxOR/PxDDR
LD A,X; check for falling edge
cp A,#02
jrne OUT
TNZ Y
jrne OUT
LD A,sema; check the semaphore status if edge is detected
CP A,#01
jrne OUT
call call_routine; call the interrupt routine
OUT:LD A,#00
LD sema,A
.call_routine; entry to call_routine
PUSH A
PUSH X
PUSH CC
.extl_rt; entry to interrupt routine
LD A,#00
LD sema,A
IRET

```

Case 2: Writing to PxOR or PxDDR with global interrupts disabled:

```

SIM; set the interrupt mask
LD A,PFDR
AND A,#$02
LD X,A; store the level before writing to PxOR/PxDDR
LD A,#$90
LD PFDDR,A; Write into PFDDR
LD A,#$ff
LD PFOR,A; Write to PFOR
LD A,PFDR
AND A,#$02
LD Y,A; store the level after writing to PxOR/PxDDR
LD A,X; check for falling edge
cp A,#$02
jrne OUT
TNZ Y
jrne OUT
LD A,#$01
LD sema,A; set the semaphore to '1' if edge is detected
RIM; reset the interrupt mask
LD A,sema; check the semaphore status
CP A,#$01
jrne OUT
call call_routine; call the interrupt routine
RIM

```

```

OUT: RIM
JP while_loop
.call_routine; entry to call_routine
PUSH A
PUSH X
PUSH CC
.ext1_rt; entry to interrupt routine
LD A,#$00
LD sema,A
IRET

```

16.1.2 Unexpected reset fetch

If an interrupt request occurs while a “POP CC” instruction is executed, the interrupt controller does not recognise the source of the interrupt and, by default, passes the reset vector address to the CPU.

Workaround

To solve this issue, a “POP CC” instruction must always be preceded by a “SIM” instruction.

16.2 Clearing active interrupts outside interrupt routine

When an active interrupt request occurs at the same time as the related flag is being cleared, an unwanted reset may occur.

Note: Clearing the related interrupt mask will not generate an unwanted reset.

Concurrent interrupt context

The symptom does not occur when the interrupts are handled normally, i.e. when:

- The interrupt flag is cleared within its own interrupt routine
- The interrupt flag is cleared within any interrupt routine
- The interrupt flag is cleared in any part of the code while this interrupt is disabled

If these conditions are not met, the symptom can be avoided by implementing the following sequence:

Perform SIM and RIM operation before and after resetting an active interrupt request.

Example:

```

SIM
reset interrupt flag
RIM

```

Nested interrupt context:

The symptom does not occur when the interrupts are handled normally, i.e. when:

- The interrupt flag is cleared within its own interrupt routine
- The interrupt flag is cleared within any interrupt routine with higher or identical priority level
- The interrupt flag is cleared in any part of the code while this interrupt is disabled

If these conditions are not met, the symptom can be avoided by implementing the following sequence:

```
PUSH CC
SIM
reset interrupt flag
POP CC
```

16.3 16-bit timer PWM mode

In PWM mode, the first PWM pulse is missed after writing the value FFFCh in the OC1R register (OC1HR, OC1LR). It leads to either full or no PWM during a period, depending on the OLVL1 and OLVL2 settings.

16.4 TIMD set simultaneously with OC interrupt

If the 16-bit timer is disabled at the same time the output compare event occurs then output compare flag gets locked and cannot be cleared before the timer is enabled again.

16.4.1 Impact on the application

If output compare interrupt is enabled, then the output compare flag cannot be cleared in the timer interrupt routine. Consequently, the interrupt service routine is called repeatedly.

16.4.2 Workaround

Disable the timer interrupt before disabling the timer. Again while enabling, first enable the timer then the timer interrupts.

Perform the following to disable the timer:

```
TACR1 = 0x00h; // Disable the compare interrupt
TACSR |= 0x40; // Disable the timer
```

Perform the following to enable the timer again:

```
TACSR &= ~0x40; // Enable the timer
TACR1 = 0x40; // Enable the compare interrupt
```

16.5 SCI wrong break duration

16.5.1 Description

A single break character is sent by setting and resetting the SBK bit in the SCICR2 register. In some cases, the break character may have a longer duration than expected:

- 20 bits instead of 10 bits if M=0
- 22 bits instead of 11 bits if M=1

In the same way, as long as the SBK bit is set, break characters are sent to the TDO pin. This may lead to generate one break more than expected.

16.5.2 Occurrence

The occurrence of the problem is random and proportional to the baud rate. With a transmit frequency of 19200 baud ($f_{CPU}=8$ MHz and SCIBRR=0xC9), the wrong break duration occurrence is around 1%.

16.5.3 Workaround

If this wrong duration is not compliant with the communication protocol in the application, software can request that an Idle line be generated before the break character. In this case, the break duration is always correct assuming the application is not doing anything between the idle and the break. This can be ensured by temporarily disabling interrupts.

The exact sequence is:

- Disable interrupts
- Reset and Set TE (IDLE request)
- Set and Reset SBK (Break request)
- Re-enable interrupts

16.6 Random read operations not supported with the standard I²C

16.6.1 Description

The standard I²C peripheral is not fully compliant with random read capabilities (only the I2C3SNS interface supports these capabilities). If the master sends a Restart condition, a bus error is generated on the ST7 device in slave mode.

16.6.2 Occurrence

The occurrence of the problem is random.

16.6.3 Workaround

The Restart condition is not allowed. The master must not send a Restart condition. It must send a Stop condition before a second Start (each Start has to be preceded by a Stop).

16.7 Programming of EEPROM data

16.7.1 Description

In user mode, when programming EEPROM data memory, the read access to the program memory between E000h and FFFFh can be corrupted.

16.7.2 Impact on application

The EEPROM programming routine must be located outside this program memory area.

Any access to the interrupt vector table can result in an unexpected code being executed, so the interrupts must be masked.

16.7.3 Workaround

The sequence to program the EEPROM data (refer to [Section 5.3](#)) must be executed within C000h-DFFFh area or from the RAM. It is as follows:

```
set E2LAT bit
write up to 32 bytes in E2PROM area
SIM ; to disable the interrupts
set E2PGM bit
wait for E2PGM=0
RIM ; to enable the interrupts
return to the program memory
```

17 Revision history

Table 126. Document revision history

Date	Revision	Changes
29-April-2006	1	First release on internet
23-Oct-2006	2	<p>Removed references to BGA56 and QFN40 packages</p> <p>TQFP package naming changed to LQFP (Low-profile Quad Flat)</p> <p>Changed number of I/O ports on first page</p> <p>PDVD (Power Down Voltage Detector) replaced by AVD (Auxiliary Voltage Detector)</p> <p>Modified note 3 to Table 4 on page 24</p> <p>Added PF4 to Figure 3 on page 18 and Figure 4 on page 19</p> <p>Modified Memory access on page 31</p> <p>Modified Figure 8, Figure 9 on page 33 and Figure 10 on page 34</p> <p>Changed RCCR table in Section 7.3 on page 43 ($f_{RC}=1$ MHz)</p> <p>References to PDVDF, PDVDIE corrected to AVDF, AVDIE: Section 7.6.2 on page 49</p> <p>Current characteristics Table 85 on page 201 updated</p> <p>General operating conditions table updated, Table 87 on page 202</p> <p>Data updated in Table 88 on page 202, note replaced</p> <p>Table modified in Table 89 on page 203</p> <p>Notes adjusted for table in Table 90 on page 203</p> <p>Modified Section 13.4 on page 204 (for $V_{DD}=5V$)</p> <p>Table in Table 93 on page 205 modified</p> <p>Updated Table 94 on page 208</p> <p>Added Table 96 on page 209 and Figure 96 on page 209</p> <p>Table in Table 101 on page 212 modified</p> <p>Absolute maximum ratings and electrical sensitivity table updated, Section 13.8.3 on page 214</p> <p>Added note 1 to V_{IL} and V_{IH} in Table 107 on page 215</p> <p>Table in Table 108 on page 216 modified (for $V_{DD}=3.3V$ and $V_{DD}=2.7V$)</p> <p>Modified graphs in Table 108 on page 216</p> <p>$t_{g(RSTL)in}$ updated in Table 13.10 on page 222</p> <p>Updated Table 111 on page 224</p> <p>Updated Table 118 on page 231</p> <p>Modified default values for option byte 2 and 3 on Option byte 2 on page 234</p> <p>Added option list on Option byte 2 on page 234</p> <p>Added Section 15.3: Development tools on page 236</p> <p>Added known limitations: Section 16.6: In-application programming on page 242, Section 16.7: Programming of EEPROM data on page 243, and Section 16.8: Flash write/erase protection on page 243</p> <p>Modified Section 16.7 on page 243</p> <p>Changed status of the document (datasheet instead of preliminary data)</p>

Table 126. Document revision history (continued)

Date	Revision	Changes
22-Sep-2008	3	<p>Document reformatted Title modified Removed references to ST72340 devices and FASTROM devices Modified device summary on first page Added note 1 and note 3 to Table 3 on page 20 and removed note on ICCDATA and ICCCLK Added note 5 and “caution” to Section 4.4 on page 28 Added one caution to Section 7.2 on page 42 Modified note in Section 7.3.3 on page 45, Added caution to Section 7.5 on page 46 Added one caution to Section 7.6.2 on page 49 Modified Figure 24 on page 60 Modified note 3 in Output compare on page 99 Added note to Section 11.8.1 on page 185 Modified table in Table 84 on page 200 Modified Section 13.4 on page 204: modified note 1 and added f_{RC} values for $V_{DD} = 3\text{ V}$ Modified Table 94 on page 208 Modified Section 13.6.1 on page 210 Modified EMC characteristics on page 213 and removed references to DLU in Absolute maximum ratings (electrical sensitivity) on page 214 Modified Section 13.10.1 on page 222 Added note 2 to Section 13.11.1 on page 224 Added Section 16.4 on page 242 Section 16.4 on page 242 Modified Section 14 on page 227 (values in inches rounded to 4 decimal digits instead of 3 decimal digits) Modified Section 15 on page 232, Device ordering information on page 236 Removed option list.</p>
11-Dec-2008	4	<p>“Flash write/erase protection” and “In-application programming” removed in Section 16: Known limitations on page 239 (limitations corrected in the silicon revision now in production). Updated Section 14.1: ECOPACK on page 227</p>
15-Jun-2009	5	<p>Modified title of Table 2 on page 16 Added Section 16.6: Random read operations not supported with the standard I²C on page 243</p>
28-Jun-2012	6	<p>Note (2) added to Table 125: Development tool order codes.</p>

Please Read Carefully:

Information in this document is provided solely in connection with ST products. STMicroelectronics NV and its subsidiaries ("ST") reserve the right to make changes, corrections, modifications or improvements, to this document, and the products and services described herein at any time, without notice.

All ST products are sold pursuant to ST's terms and conditions of sale.

Purchasers are solely responsible for the choice, selection and use of the ST products and services described herein, and ST assumes no liability whatsoever relating to the choice, selection or use of the ST products and services described herein.

No license, express or implied, by estoppel or otherwise, to any intellectual property rights is granted under this document. If any part of this document refers to any third party products or services it shall not be deemed a license grant by ST for the use of such third party products or services, or any intellectual property contained therein or considered as a warranty covering the use in any manner whatsoever of such third party products or services or any intellectual property contained therein.

UNLESS OTHERWISE SET FORTH IN ST'S TERMS AND CONDITIONS OF SALE ST DISCLAIMS ANY EXPRESS OR IMPLIED WARRANTY WITH RESPECT TO THE USE AND/OR SALE OF ST PRODUCTS INCLUDING WITHOUT LIMITATION IMPLIED WARRANTIES OF MERCHANTABILITY, FITNESS FOR A PARTICULAR PURPOSE (AND THEIR EQUIVALENTS UNDER THE LAWS OF ANY JURISDICTION), OR INFRINGEMENT OF ANY PATENT, COPYRIGHT OR OTHER INTELLECTUAL PROPERTY RIGHT.

UNLESS EXPRESSLY APPROVED IN WRITING BY TWO AUTHORIZED ST REPRESENTATIVES, ST PRODUCTS ARE NOT RECOMMENDED, AUTHORIZED OR WARRANTED FOR USE IN MILITARY, AIR CRAFT, SPACE, LIFE SAVING, OR LIFE SUSTAINING APPLICATIONS, NOR IN PRODUCTS OR SYSTEMS WHERE FAILURE OR MALFUNCTION MAY RESULT IN PERSONAL INJURY, DEATH, OR SEVERE PROPERTY OR ENVIRONMENTAL DAMAGE. ST PRODUCTS WHICH ARE NOT SPECIFIED AS "AUTOMOTIVE GRADE" MAY ONLY BE USED IN AUTOMOTIVE APPLICATIONS AT USER'S OWN RISK.

Resale of ST products with provisions different from the statements and/or technical features set forth in this document shall immediately void any warranty granted by ST for the ST product or service described herein and shall not create or extend in any manner whatsoever, any liability of ST.

ST and the ST logo are trademarks or registered trademarks of ST in various countries.

Information in this document supersedes and replaces all information previously supplied.

The ST logo is a registered trademark of STMicroelectronics. All other names are the property of their respective owners.

© 2012 STMicroelectronics - All rights reserved

STMicroelectronics group of companies

Australia - Belgium - Brazil - Canada - China - Czech Republic - Finland - France - Germany - Hong Kong - India - Israel - Italy - Japan - Malaysia - Malta - Morocco - Philippines - Singapore - Spain - Sweden - Switzerland - United Kingdom - United States of America

www.st.com

