



## LRIS64K

64 Kbit EEPROM tag IC at 13.56 MHz with 64-bit UID and password based on ISO/IEC 15693 and ISO/IEC 18000-3 Mode 1

### Features

- Based on ISO/IEC 15693 and ISO/IEC 18000-3 mode 1 standards
- 13.56 MHz  $\pm$ 7 kHz carrier frequency
- To tag: 10% or 100% ASK modulation using 1/4 (26 Kbit/s) or 1/256 (1.6 Kbit/s) pulse position coding
- From tag: load modulation using Manchester coding with 423 kHz and 484 kHz subcarriers in low (6.6 Kbit/s) or high (26 Kbit/s) data rate mode. Supports the 53 Kbit/s data rate with Fast commands
- Internal tuning capacitor (27.5 pF)
- More than 1 million write cycles
- More than 40-year data retention
- 64 Kbit EEPROM organized into 2048 blocks of 32 bits
- 64-bit unique identifier (UID)
- Multipassword protection
- Read Block & Write (32-bit blocks)
- Write time: 5.75 ms including the internal verify

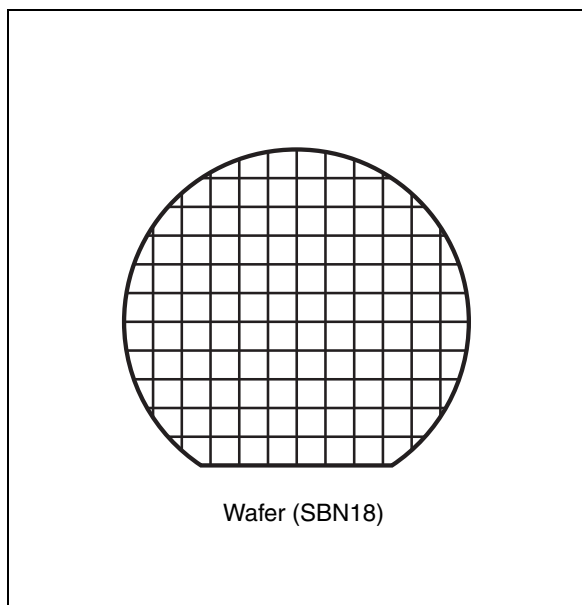

# Contents

<b>1</b>	<b>Description</b> .....	<b>10</b>
<b>2</b>	<b>User memory organization</b> .....	<b>11</b>
<b>3</b>	<b>System memory area</b> .....	<b>15</b>
3.1	LRIS64K RF block security .....	15
3.2	Example of the LRIS64K security protection .....	17
<b>4</b>	<b>Initial delivery state</b> .....	<b>18</b>
<b>5</b>	<b>Commands</b> .....	<b>19</b>
5.1	Initial dialogue for vicinity cards .....	20
5.1.1	Power transfer .....	20
5.1.2	Frequency .....	20
5.1.3	Operating field .....	20
<b>6</b>	<b>Communication signal from VCD to LRIS64K</b> .....	<b>21</b>
<b>7</b>	<b>Data rate and data coding</b> .....	<b>23</b>
7.1	Data coding mode: 1 out of 256 .....	23
7.2	Data coding mode: 1 out of 4 .....	24
7.3	VCD to LRIS64K frames .....	26
7.4	Start of frame (SOF) .....	26
<b>8</b>	<b>Communications signal from LRIS64K to VCD</b> .....	<b>27</b>
8.1	Load modulation .....	27
8.2	Subcarrier .....	27
8.3	Data rates .....	27
<b>9</b>	<b>Bit representation and coding</b> .....	<b>28</b>
9.1	Bit coding using one subcarrier .....	28
9.1.1	High data rate .....	28
9.1.2	Low data rate .....	29
9.2	Bit coding using two subcarriers .....	30

9.3	High data rate .....	30
9.4	Low data rate .....	30
<b>10</b>	<b>LRIS64K to VCD frames .....</b>	<b>31</b>
10.1	SOF when using one subcarrier .....	31
10.2	High data rate .....	31
10.3	Low data rate .....	31
10.4	SOF when using two subcarriers .....	32
10.5	High data rate .....	32
10.6	Low data rate .....	32
10.7	EOF when using one subcarrier .....	33
10.8	High data rate .....	33
10.9	Low data rate .....	33
10.10	EOF when using two subcarriers .....	34
10.11	High data rate .....	34
10.12	Low data rate .....	34
<b>11</b>	<b>Unique identifier (UID) .....</b>	<b>35</b>
<b>12</b>	<b>Application family identifier (AFI) .....</b>	<b>36</b>
<b>13</b>	<b>Data storage format identifier (DSFID) .....</b>	<b>37</b>
13.1	CRC .....	37
<b>14</b>	<b>LRIS64K protocol description .....</b>	<b>38</b>
<b>15</b>	<b>LRIS64K states .....</b>	<b>40</b>
15.1	Power-off state .....	40
15.2	Ready state .....	40
15.3	Quiet state .....	40
15.4	Selected state .....	40
<b>16</b>	<b>Modes .....</b>	<b>42</b>
16.1	Addressed mode .....	42
16.2	Non-addressed mode (general request) .....	42

16.3	Select mode .....	42
<b>17</b>	<b>Request format .....</b>	<b>43</b>
17.1	Request flags .....	43
<b>18</b>	<b>Response format .....</b>	<b>45</b>
18.1	Response flags .....	45
18.2	Response error code .....	46
<b>19</b>	<b>Anticollision .....</b>	<b>47</b>
19.1	Request parameters .....	47
<b>20</b>	<b>Request processing by the LRIS64K .....</b>	<b>49</b>
<b>21</b>	<b>Explanation of the possible cases .....</b>	<b>50</b>
<b>22</b>	<b>Inventory Initiated command .....</b>	<b>52</b>
<b>23</b>	<b>Timing definition .....</b>	<b>53</b>
23.1	t <sub>1</sub> : LRIS64K response delay .....	53
23.2	t <sub>2</sub> : VCD new request delay .....	53
23.3	t <sub>3</sub> : VCD new request delay in the absence of a response from the LRIS64K .....	53
<b>24</b>	<b>Commands codes .....</b>	<b>54</b>
24.1	Inventory .....	55
24.2	Stay Quiet .....	56
24.3	Read Single Block .....	57
24.4	Write Single Block .....	59
24.5	Read Multiple Block .....	61
24.6	Select .....	63
24.7	Reset to Ready .....	64
24.8	Write AFI .....	65
24.9	Lock AFI .....	67
24.10	Write DSFID .....	69
24.11	Lock DSFID .....	71

24.12	Get System Info	73
24.13	Get Multiple Block Security Status	75
24.14	Write-sector Password	77
24.15	Lock-sector Password	79
24.16	Present-sector Password	81
24.17	Fast Read Single Block	83
24.18	Fast Inventory Initiated	85
24.19	Fast Initiate	86
24.20	Fast Read Multiple Block	87
24.21	Inventory Initiated	89
24.22	Initiate	90
<b>25</b>	<b>Maximum rating</b>	<b>91</b>
<b>26</b>	<b>RF DC and AC parameters</b>	<b>92</b>
<b>27</b>	<b>Part numbering</b>	<b>94</b>
<b>Appendix A</b>	<b>Anticollision algorithm</b>	<b>95</b>
A.1	Algorithm for pulsed slots	95
<b>Appendix B</b>	<b>CRC</b>	<b>96</b>
B.1	CRC error detection method	96
B.2	CRC calculation example	96
<b>Appendix C</b>	<b>Application family identifier (AFI)</b>	<b>98</b>
	<b>Revision history</b>	<b>99</b>

## List of tables

Table 1.	Signal names	10
Table 2.	Sector details	12
Table 3.	Sector security status byte area	15
Table 4.	Sector security status byte organization	15
Table 5.	Read / Write protection bit setting	16
Table 6.	Password Control bits	16
Table 7.	Password system area	16
Table 8.	Sector security protection after power-up	17
Table 9.	Sector security protection after a valid presentation of password 1	17
Table 10.	10% modulation parameters	21
Table 11.	Response data rates	27
Table 12.	UID format	35
Table 13.	CRC transmission rules	37
Table 14.	VCD request frame format	38
Table 15.	LRIS64K Response frame format	38
Table 16.	LRIS64K response depending on Request_flags	41
Table 17.	General request format	43
Table 18.	Definition of request flags 1 to 4	43
Table 19.	Request flags 5 to 8 when Bit 3 = 0	44
Table 20.	Request flags 5 to 8 when Bit 3 = 1	44
Table 21.	General response format	45
Table 22.	Definitions of response flags 1 to 8	45
Table 23.	Response error code definition	46
Table 24.	Inventory request format	47
Table 25.	Example of the addition of 0-bits to an 11-bit mask value	47
Table 26.	Timing values	53
Table 27.	Command codes	54
Table 28.	Inventory request format	55
Table 29.	Inventory response format	55
Table 30.	Stay Quiet request format	56
Table 31.	Read Single Block request format	57
Table 32.	Read Single Block response format when Error_flag is NOT set	57
Table 33.	Sector security status	57
Table 34.	Read Single Block response format when Error_flag is set	57
Table 35.	Write Single Block request format	59
Table 36.	Write Single Block response format when Error_flag is NOT set	59
Table 37.	Write Single Block response format when Error_flag is set	59
Table 38.	Read Multiple Block request format	61
Table 39.	Read Multiple Block response format when Error_flag is NOT set	61
Table 40.	Sector security status	61
Table 41.	Read Multiple Block response format when Error_flag is set	62
Table 42.	Select request format	63
Table 43.	Select Block response format when Error_flag is NOT set	63
Table 44.	Select response format when Error_flag is set	63
Table 45.	Reset to Ready request format	64
Table 46.	Reset to Ready response format when Error_flag is NOT set	64
Table 47.	Reset to ready response format when Error_flag is set	64
Table 48.	Write AFI request format	65

Table 49.	Write AFI response format when Error_flag is NOT set . . . . .	65
Table 50.	Write AFI response format when Error_flag is set . . . . .	65
Table 51.	Lock AFI request format . . . . .	67
Table 52.	Lock AFI response format when Error_flag is NOT set . . . . .	67
Table 53.	Lock AFI response format when Error_flag is set . . . . .	67
Table 54.	Write DSFID request format . . . . .	69
Table 55.	Write DSFID response format when Error_flag is NOT set . . . . .	69
Table 56.	Write DSFID response format when Error_flag is set . . . . .	69
Table 57.	Lock DSFID request format . . . . .	71
Table 58.	Lock DSFID response format when Error_flag is NOT set . . . . .	71
Table 59.	Lock DSFID response format when Error_flag is set . . . . .	71
Table 60.	Get System Info request format . . . . .	73
Table 61.	Get System Info response format when Error_flag is NOT set . . . . .	73
Table 62.	Get System Info response format when Error_flag is set . . . . .	73
Table 63.	Get Multiple Block Security Status request format . . . . .	75
Table 64.	Get Multiple Block Security Status response format when Error_flag is NOT set . . . . .	75
Table 65.	Sector security status . . . . .	75
Table 66.	Get Multiple Block Security Status response format when Error_flag is set . . . . .	76
Table 67.	Write-sector Password request format . . . . .	77
Table 68.	Write-sector Password response format when Error_flag is NOT set . . . . .	77
Table 69.	Write-sector Password response format when Error_flag is set . . . . .	77
Table 70.	Lock-sector Password request format . . . . .	79
Table 71.	Sector security status . . . . .	79
Table 72.	Lock-sector Password response format when Error_flag is NOT set . . . . .	79
Table 73.	Lock-sector Password response format when Error_flag is set . . . . .	79
Table 74.	Present-sector Password request format . . . . .	81
Table 75.	Present-sector Password response format when Error_flag is NOT set . . . . .	81
Table 76.	Present-sector Password response format when Error_flag is set . . . . .	81
Table 77.	Fast Read Single Block request format . . . . .	83
Table 78.	Fast Read Single Block response format when Error_flag is NOT set . . . . .	83
Table 79.	Sector security status . . . . .	83
Table 80.	Fast Read Single Block response format when Error_flag is set . . . . .	83
Table 81.	Fast Inventory Initiated request format . . . . .	85
Table 82.	Fast Inventory Initiated response format . . . . .	85
Table 83.	Fast Initiate request format . . . . .	86
Table 84.	Fast Initiate response format . . . . .	86
Table 85.	Fast Read Multiple Block request format . . . . .	87
Table 86.	Fast Read Multiple Block response format when Error_flag is NOT set . . . . .	87
Table 87.	Sector security status if Option_flag is set . . . . .	87
Table 88.	Fast Read Multiple Block response format when Error_flag is set . . . . .	88
Table 89.	Inventory Initiated request format . . . . .	89
Table 90.	Inventory Initiated response format . . . . .	89
Table 91.	Initiate request format . . . . .	90
Table 92.	Initiate Initiated response format . . . . .	90
Table 93.	Absolute maximum ratings . . . . .	91
Table 94.	RF AC characteristics . . . . .	92
Table 95.	RF DC characteristics . . . . .	93
Table 96.	Operating conditions . . . . .	93
Table 97.	Ordering information scheme . . . . .	94
Table 98.	CRC definition . . . . .	96
Table 99.	AFI coding . . . . .	98
Table 100.	Document revision history . . . . .	99

## List of figures

Figure 1.	Pad connection . . . . .	10
Figure 2.	Memory sector organization . . . . .	11
Figure 3.	100% modulation waveform . . . . .	21
Figure 4.	10% modulation waveform . . . . .	22
Figure 5.	1 out of 256 coding mode . . . . .	23
Figure 6.	Detail of a time period . . . . .	24
Figure 7.	1 out of 4 coding mode . . . . .	25
Figure 8.	1 out of 4 coding example. . . . .	25
Figure 9.	SOF to select 1 out of 256 data coding mode . . . . .	26
Figure 10.	SOF to select 1 out of 4 data coding mode . . . . .	26
Figure 11.	EOF for either data coding mode . . . . .	26
Figure 12.	Logic 0, high data rate, one subcarriers . . . . .	28
Figure 13.	Logic 0, high data rate, one subcarriers x2. . . . .	28
Figure 14.	Logic 1, high data rate, one subcarriers . . . . .	28
Figure 15.	Logic 1, high data rate, one subcarriers x2. . . . .	28
Figure 16.	Logic 0, low data rate, one subcarriers . . . . .	29
Figure 17.	Logic 0, low data rate, one subcarriers x2 . . . . .	29
Figure 18.	Logic 1, low data rate, one subcarriers . . . . .	29
Figure 19.	Logic 1, low data rate, one subcarriers x2 . . . . .	29
Figure 20.	Logic 0, high data rate, two subcarriers . . . . .	30
Figure 21.	Logic 1, high data rate, two subcarriers . . . . .	30
Figure 22.	Logic 0, low data rate, two subcarriers . . . . .	30
Figure 23.	Logic 1, low data rate, two subcarriers . . . . .	30
Figure 24.	Start of frame, high data rate, one subcarrier . . . . .	31
Figure 25.	Start of frame, high data rate, one subcarrier x2 . . . . .	31
Figure 26.	Start of frame, low data rate, one subcarrier . . . . .	31
Figure 27.	Start of frame, low data rate, one subcarrier x2 . . . . .	32
Figure 28.	Start of frame, high data rate, two subcarriers . . . . .	32
Figure 29.	Start of frame, low data rate, two subcarriers . . . . .	32
Figure 30.	End of frame, high data rate, one subcarriers . . . . .	33
Figure 31.	End of frame, high data rate, one subcarriers x2 . . . . .	33
Figure 32.	End of frame, low data rate, one subcarriers . . . . .	33
Figure 33.	End of frame, low data rate, one subcarriers x2. . . . .	33
Figure 34.	End of frame, high data rate, two subcarriers. . . . .	34
Figure 35.	End of frame, low data rate, two subcarriers . . . . .	34
Figure 36.	LRIS64K decision tree for AFI . . . . .	36
Figure 37.	LRIS64K protocol timing . . . . .	39
Figure 38.	LRIS64K state transition diagram . . . . .	41
Figure 39.	Principle of comparison between the mask, the slot number and the UID . . . . .	48
Figure 40.	Description of a possible anticollision sequence . . . . .	51
Figure 41.	Stay Quiet frame exchange between VCD and LRIS64K. . . . .	56
Figure 42.	Read Single Block frame exchange between VCD and LRIS64K . . . . .	58
Figure 43.	Write Single Block frame exchange between VCD and LRIS64K . . . . .	60
Figure 44.	Read Multiple Block frame exchange between VCD and LRIS64K . . . . .	62
Figure 45.	Select frame exchange between VCD and LRIS64K . . . . .	63
Figure 46.	Reset to Ready frame exchange between VCD and LRIS64K. . . . .	64
Figure 47.	Write AFI frame exchange between VCD and LRIS64K . . . . .	66
Figure 48.	Lock AFI frame exchange between VCD and LRIS64K . . . . .	68

---

Figure 49.	Write DSFID frame exchange between VCD and LRIS64K .....	70
Figure 50.	Lock DSFID frame exchange between VCD and LRIS64K .....	72
Figure 51.	Get System Info frame exchange between VCD and LRIS64K .....	74
Figure 52.	Get Multiple Block Security Status frame exchange between VCD and LRIS64K .....	76
Figure 53.	Write-sector Password frame exchange between VCD and LRIS64K .....	78
Figure 54.	Lock-sector Password frame exchange between VCD and LRIS64K .....	80
Figure 55.	Present-sector Password frame exchange between VCD and LRIS64K .....	82
Figure 56.	Fast Read Single Block frame exchange between VCD and LRIS64K .....	84
Figure 57.	Fast Initiate frame exchange between VCD and LRIS64K .....	86
Figure 58.	Fast Read Multiple Block frame exchange between VCD and LRIS64K .....	88
Figure 59.	Initiate frame exchange between VCD and LRIS64K .....	90
Figure 60.	LRIS64K synchronous timing, transmit and receive .....	93

# 1 Description

The LRIS64K is a contactless memory powered by the received carrier electromagnetic wave, which follows the ISO/IEC 15693 and ISO/IEC 18000-3 mode 1 recommendation for radio-frequency power and signal interface. It is a 64 Kbit electrically erasable programmable memory (EEPROM). The memory is organized as 64 sectors divided into 32 blocks of 32 bits.

The LRIS64K is accessed via the 13.56 MHz carrier electromagnetic wave, on which incoming data are demodulated from the received signal amplitude modulation (ASK: amplitude shift keying). The received ASK wave is 10% or 100% modulated with a data rate of 1.6 Kbit/s using the 1/256 pulse coding mode, or a data rate of 26 Kbit/s using the 1/4 pulse coding mode. Outgoing data are generated by the LRIS64K load variation using Manchester coding with one or two subcarrier frequencies at 423 kHz and 484 kHz. Data are transferred from the LRIS64K at 6.6 Kbit/s in low data rate mode and 26 Kbit/s in high data rate mode. The LRIS64K supports the 53 Kbit/s data rate in high data rate mode with a single subcarrier frequency of 423 kHz.

The LRIS64K also features a unique 32-bit multi-password protection scheme.

**Figure 1. Pad connection**

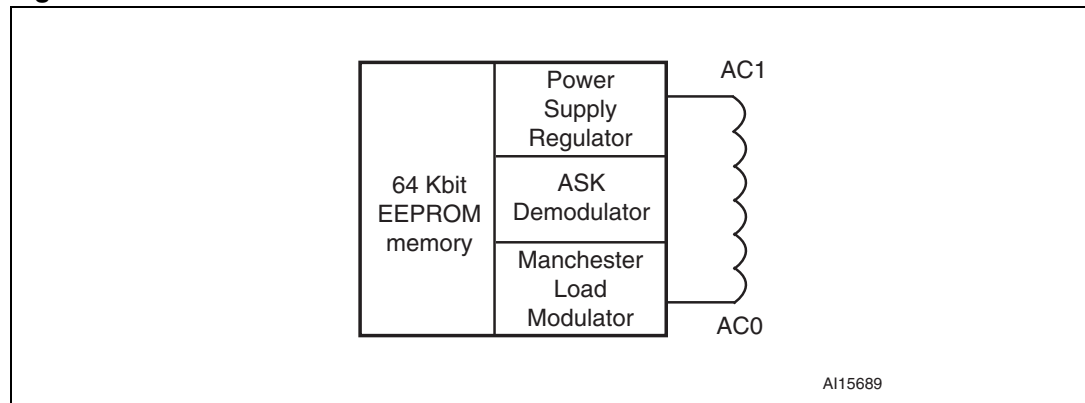

**Table 1. Signal names**

Signal name	Function	Direction
AC0	Antenna coil	I/O
AC1	Antenna coil	I/O

## 2 User memory organization

The LRIS64K is divided into 64 sectors of 32 blocks of 32 bits as shown in [Table 2](#). [Figure 2](#) shows the memory sector organization. Each sector can be individually read- and/or write-protected using a specific password command. Read and write operations are possible if the addressed data are not in a protected sector.

The LRIS64K also has a 64-bit block that is used to store the 64-bit unique identifier (UID). The UID is compliant with the ISO/IEC 15963 description, and its value is used during the anticollision sequence (Inventory). This block is not accessible by the user and its value is written by ST on the production line.

The LRIS64K includes an AFI register that stores the application family identifier, and a DSFID register that stores the data storage family identifier used in the anticollision algorithm.

The LRIS64K has three additional 32-bit blocks that store the RF password codes.

**Figure 2. Memory sector organization**

Sector	Area	Sector security status
0	1 Kbit EEPROM sector	5 bits
1	1 Kbit EEPROM sector	5 bits
2	1 Kbit EEPROM sector	5 bits
3	1 Kbit EEPROM sector	5 bits
60	1 Kbit EEPROM sector	5 bits
61	1 Kbit EEPROM sector	5 bits
62	1 Kbit EEPROM sector	5 bits
63	1 Kbit EEPROM sector	5 bits
	RF Password 1	System
	RF Password 2	System
	RF Password 3	System
	8 bit DSFID	System
	8 bit AFI	System
	64 bit UID	System

ai15849

### Sector details

The LRIS64K user memory is divided into 64 sectors. Each sector contains 1024 bits. The protection scheme is described in [Section 3: System memory area](#).

A sector provides 32 blocks of 32 bits. Each read and write access are done by block. Read and write block accesses are controlled by a Sector Security Status byte that defines the access rights to all the 32 blocks contained in the sector. If the sector is not protected, a Write command updates the complete 32 bits of the selected block.

**Table 2. Sector details**

Sector number	RF block address	Bits [31:24]	Bits [23:16]	Bits [15:8]	Bits [7:0]
0	0	user	user	user	user
	1	user	user	user	user
	2	user	user	user	user
	3	user	user	user	user
	4	user	user	user	user
	5	user	user	user	user
	6	user	user	user	user
	7	user	user	user	user
	8	user	user	user	user
	9	user	user	user	user
	10	user	user	user	user
	11	user	user	user	user
	12	user	user	user	user
	13	user	user	user	user
	14	user	user	user	user
	15	user	user	user	user
	16	user	user	user	user
	17	user	user	user	user
	18	user	user	user	user
	19	user	user	user	user
	20	user	user	user	user
	21	user	user	user	user
	22	user	user	user	user
	23	user	user	user	user
	24	user	user	user	user
	25	user	user	user	user
	26	user	user	user	user
	27	user	user	user	user
	28	user	user	user	user
	29	user	user	user	user
	30	user	user	user	user
	31	user	user	user	user

**Table 2. Sector details (continued)**

Sector number	RF block address	Bits [31:24]	Bits [23:16]	Bits [15:8]	Bits [7:0]
1	32	user	user	user	user
	33	user	user	user	user
	34	user	user	user	user
	35	user	user	user	user
	36	user	user	user	user
	37	user	user	user	user
	38	user	user	user	user
	39	user	user	user	user
	...	...	...	...	...
...	...	...	...	...	...
63	2016	user	user	user	user
	2017	user	user	user	user
	2018	user	user	user	user
	2019	user	user	user	user
	2020	user	user	user	user
	2021	user	user	user	user
	2022	user	user	user	user
	2023	user	user	user	user
	2024	user	user	user	user
	2025	user	user	user	user
	2026	user	user	user	user
	2027	user	user	user	user
	2028	user	user	user	user
	2029	user	user	user	user
	2030	user	user	user	user
	2031	user	user	user	user
	2032	user	user	user	user
	2033	user	user	user	user
	2034	user	user	user	user
	2035	user	user	user	user
2036	user	user	user	user	
2037	user	user	user	user	
2038	user	user	user	user	
2039	user	user	user	user	

Table 2. Sector details (continued)

Sector number	RF block address	Bits [31:24]	Bits [23:16]	Bits [15:8]	Bits [7:0]
63 continued	2040	user	user	user	user
	2041	user	user	user	user
	2042	user	user	user	user
	2043	user	user	user	user
	2044	user	user	user	user
	2045	user	user	user	user
	2046	user	user	user	user
	2047	user	user	user	user

## 3 System memory area

### 3.1 LRIS64K RF block security

The LRIS64K provides a special protection mechanism based on passwords. Each memory sector of the LRIS64K can be individually protected by one out of three available passwords, and each sector can also have Read/Write access conditions set.

Each memory sector of the LRIS64K is assigned with a Sector security status byte including a Sector Lock bit, two Password Control bits and two Read/Write protection bits as shown in [Table 4](#). [Table 3](#) describes the organization of the Sector security status byte which can be read using the Read Single Block and Read Multiple Block commands with the Option\_flag set to '1'.

On delivery, the default value of the SSS bytes is reset to 00h.

**Table 3. Sector security status byte area**

RF address	Bits [31:24]	Bits [23:16]	Bits [15:8]	Bits [7:0]
0	SSS 3	SSS 2	SSS 1	SSS 0
128	SSS 7	SSS 6	SSS 5	SSS 4
256	SSS 11	SSS 10	SSS 9	SSS 8
384	SSS 15	SSS 14	SSS 13	SSS 12
512	SSS 19	SSS 18	SSS 17	SSS 16
640	SSS 23	SSS 22	SSS 21	SSS 20
768	SSS 27	SSS 26	SSS 25	SSS 24
896	SSS 31	SSS 30	SSS 29	SSS 28
1024	SSS 35	SSS 34	SSS 33	SSS 32
1152	SSS 39	SSS 38	SSS 37	SSS 36
1280	SSS 43	SSS 42	SSS 41	SSS 40
1408	SSS 47	SSS 46	SSS 45	SSS 44
1536	SSS 51	SSS 50	SSS 49	SSS 48
1664	SSS 55	SSS 54	SSS 53	SSS 52
1792	SSS 59	SSS 58	SSS 57	SSS 56
1920	SSS 63	SSS 62	SSS 61	SSS 60

**Table 4. Sector security status byte organization**

b <sub>7</sub>	b <sub>6</sub>	b <sub>5</sub>	b <sub>4</sub>	b <sub>3</sub>	b <sub>2</sub>	b <sub>1</sub>	b <sub>0</sub>
0	0	0	Password Control bits		Read / Write protection bits		Sector Lock

When the Sector Lock bit is set to '1', for instance by issuing a Lock-sector Password command, the 2 Read/Write protection bits (b<sub>1</sub>, b<sub>2</sub>) are used to set the Read/Write access of the sector as described in [Table 5](#).

**Table 5. Read / Write protection bit setting**

Sector Lock	b <sub>2</sub> , b <sub>1</sub>	Sector access when password presented		Sector access when password not presented	
		Read	Write	Read	Write
0	xx	Read	Write	Read	Write
1	00	Read	Write	Read	No Write
1	01	Read	Write	Read	Write
1	10	Read	Write	No Read	No Write
1	11	Read	No Write	No Read	No Write

The next 2 bits of the Sector security status byte (b<sub>3</sub>, b<sub>4</sub>) are the Password Control bits. The value these two bits is used to link a password to the sector as defined in [Table 6](#).

**Table 6. Password Control bits**

b <sub>4</sub> , b <sub>3</sub>	Password
00	The sector is not protected by a Password
01	The sector is protected by the Password 1
10	The sector is protected by the Password 2
11	The sector is protected by the Password 3

The LRIS64K password protection is organized around a dedicated set of commands plus a system area of three password blocks where the password values are stored. This system area is described in [Table 7](#).

**Table 7. Password system area**

Add	0	7	8	15	16	23	24	31
1	Password 1							
2	Password 2							
3	Password 3							

The dedicated password commands are:

- **Write-sector Password**  
 The Write-sector Password command is used to write a 32-bit block into the password system area. This command must be used to update password values. After the write cycle, the new password value is automatically activated. It is possible to modify a password value after issuing a valid Present-sector Password command. On delivery, the three default password values are set to 0000 0000h and are activated.
- **Lock-sector Password**  
 The Lock-sector Password command is used to set the Sector security status byte of the selected sector. Bits b<sub>4</sub> to b<sub>1</sub> of the Sector security status byte are affected by the

Lock-sector Password command. The Sector Lock bit,  $b_0$ , is set to '1' automatically. After issuing a Lock-sector Password command, the protection settings of the selected sector are activated. The protection of a locked block cannot be changed. A Lock-sector Password command sent to a locked sector returns an error code.

- **Present-sector Password**

The Present-sector Password command is used to present one of the three passwords to the LRIS64K in order to modify the access rights of all the memory sectors linked to that password ([Table 5](#)) including the password itself. If the presented password is correct, the access rights remain activated until the tag is powered off or until a new Present-sector Password command is issued. If the presented password value is not correct, all the access rights of all the memory sectors are deactivated.

## 3.2 Example of the LRIS64K security protection

[Table 8](#) and [Table 9](#) show the sector security protections before and after a valid Present-sector Password command. [Table 8](#) shows the sector access rights of an LRIS64K after power-up. After a valid Present-sector Password command with password 1, the memory sector access is changed as shown in [Table 9](#).

**Table 8. Sector security protection after power-up**

Sector address				Sector security status byte					
				$b_7b_6b_5$	$b_4$	$b_3$	$b_2$	$b_1$	$b_0$
0	Protection: Standard	Read	No Write	xxx	0	0	0	0	1
1	Protection: Pswd 1	Read	No Write	xxx	0	1	0	0	1
2	Protection: Pswd 1	Read	Write	xxx	0	1	0	1	1
3	Protection: Pswd 1	No Read	No Write	xxx	0	1	1	0	1
4	Protection: Pswd 1	No Read	No Write	xxx	0	1	1	1	1

**Table 9. Sector security protection after a valid presentation of password 1**

Sector address				Sector security status byte					
				$b_7b_6b_5$	$b_4$	$b_3$	$b_2$	$b_1$	$b_0$
0	Protection: Standard	Read	No Write	xxx	0	0	0	0	1
1	Protection: Pswd 1	Read	Write	xxx	0	1	0	0	1
2	Protection: Pswd 1	Read	Write	xxx	0	1	0	1	1
3	Protection: Pswd 1	Read	Write	xxx	0	1	1	0	1
4	Protection: Pswd 1	Read	No Write	xxx	0	1	1	1	1

## 4 Initial delivery state

The device is delivered with the following factory settings:

- All bits in the memory array are set to 1 (each byte contains FFh).
- The default value of the SSS bytes is reset to 00h.
- The three default password values are set to 0000 0000h and are activated.

System parameters are set to:

- (E0 02 xx xx xx xx xx xx )h for UID
- (03 07 FF)h for Memory Size
- 00h for AFI
- 00h for DSFID

## 5 Commands

The LRIS64K supports the following commands:

- **Inventory**, used to perform the anticollision sequence.
- **Stay Quiet**, used to put the LRIS64K in quiet mode, where it does not respond to any inventory command.
- **Select**, used to select the LRIS64K. After this command, the LRIS64K processes all Read/Write commands with Select\_flag set.
- **Reset To Ready**, used to put the LRIS64K in the ready state.
- **Read Block**, used to output the 32 bits of the selected block and its locking status.
- **Write Block**, used to write the 32-bit value in the selected block, provided that it is not locked.
- **Read Multiple Blocks**, used to read the selected blocks and send back their value.
- **Write AFI**, used to write the 8-bit value in the AFI register.
- **Lock AFI**, used to lock the AFI register.
- **Write DSFID**, used to write the 8-bit value in the DSFID register.
- **Lock DSFID**, used to lock the DSFID register.
- **Get System Info**, used to provide the system information value
- **Get Multiple Block Security Status**, used to send the security status of the selected block.
- **Initiate**, used to trigger the tag response to the Inventory Initiated sequence.
- **Inventory Initiated**, used to perform the anticollision sequence triggered by the Initiate command.
- **Write-sector Password**, used to write the 32 bits of the selected password.
- **Lock-sector Password**, used to write the Sector security status bits of the selected sector.
- **Present-sector Password**, enables the user to present a password to unprotect the user blocks linked to this password.
- **Fast Initiate**, used to trigger the tag response to the Inventory Initiated sequence.
- **Fast Inventory Initiated**, used to perform the anticollision sequence triggered by the Initiate command.
- **Fast Read Single Block**, used to output the 32 bits of the selected block and its locking status.
- **Fast Read Multiple Blocks**, used to read the selected blocks and send back their value.

## 5.1 Initial dialogue for vicinity cards

The dialog between the vicinity coupling device (VCD) and the vicinity integrated circuit Card or VICC (LRIS64K) takes place as follows:

- activation of the LRIS64K by the RF operating field of the VCD.
- transmission of a command by the VCD.
- transmission of a response by the LRIS64K.

These operations use the RF power transfer and communication signal interface described below (see [Power transfer](#), [Frequency](#) and [Operating field](#)). This technique is called RTF (Reader Talk First).

### 5.1.1 Power transfer

Power is transferred to the LRIS64K by radio frequency at 13.56 MHz via coupling antennas in the LRIS64K and the VCD. The RF operating field of the VCD is transformed on the LRIS64K antenna to an AC Voltage which is rectified, filtered and internally regulated. The amplitude modulation (ASK) on this received signal is demodulated by the ASK demodulator.

### 5.1.2 Frequency

The ISO/IEC 15693 standard defines the carrier frequency ( $f_C$ ) of the operating field as 13.56 MHz  $\pm$ 7 kHz.

### 5.1.3 Operating field

The LRIS64K operates continuously between  $H_{\min}$  and  $H_{\max}$ .

- The minimum operating field is  $H_{\min}$  and has a value of 150 mA/m rms.
- The maximum operating field is  $H_{\max}$  and has a value of 5 A/m rms.

A VCD shall generate a field of at least  $H_{\min}$  and not exceeding  $H_{\max}$  in the operating volume.

## 6 Communication signal from VCD to LRIS64K

Communications between the VCD and the LRIS64K takes place using the modulation principle of ASK (Amplitude Shift Keying). Two modulation indexes are used, 10% and 100%. The LRIS64K decodes both. The VCD determines which index is used.

The modulation index is defined as  $[a - b]/[a + b]$  where a is the peak signal amplitude and b, the minimum signal amplitude of the carrier frequency.

Depending on the choice made by the VCD, a “pause” will be created as described in [Figure 3](#) and [Figure 4](#).

The LRIS64K is operational for any degree of modulation index from between 10% and 30%.

**Figure 3. 100% modulation waveform**

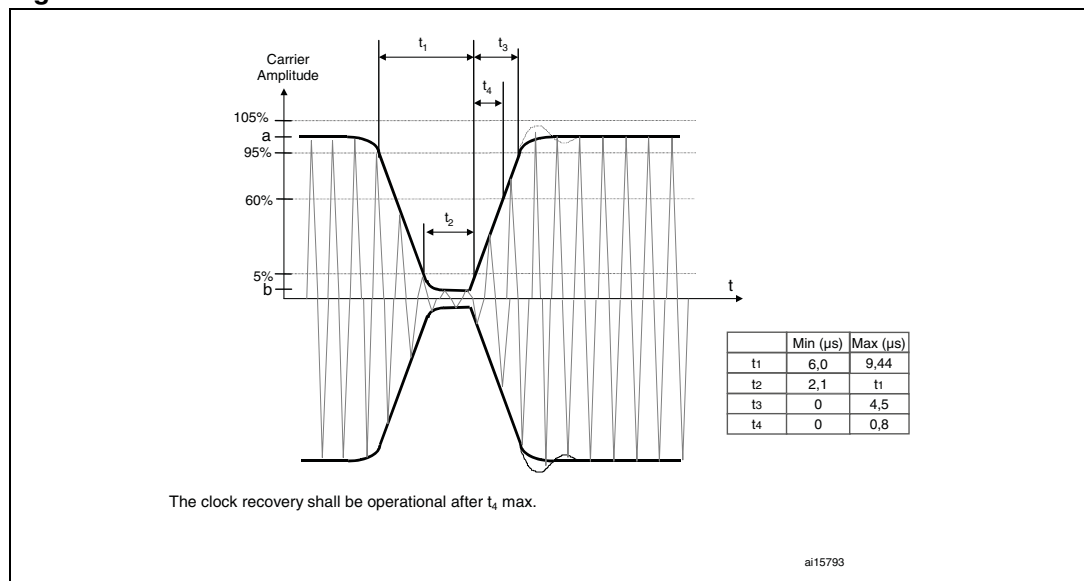

**Table 10. 10% modulation parameters**

Symbol	Parameter definition	Value
hr	$0.1 \times (a - b)$	Max
hf	$0.1 \times (a - b)$	Max

Figure 4. 10% modulation waveform

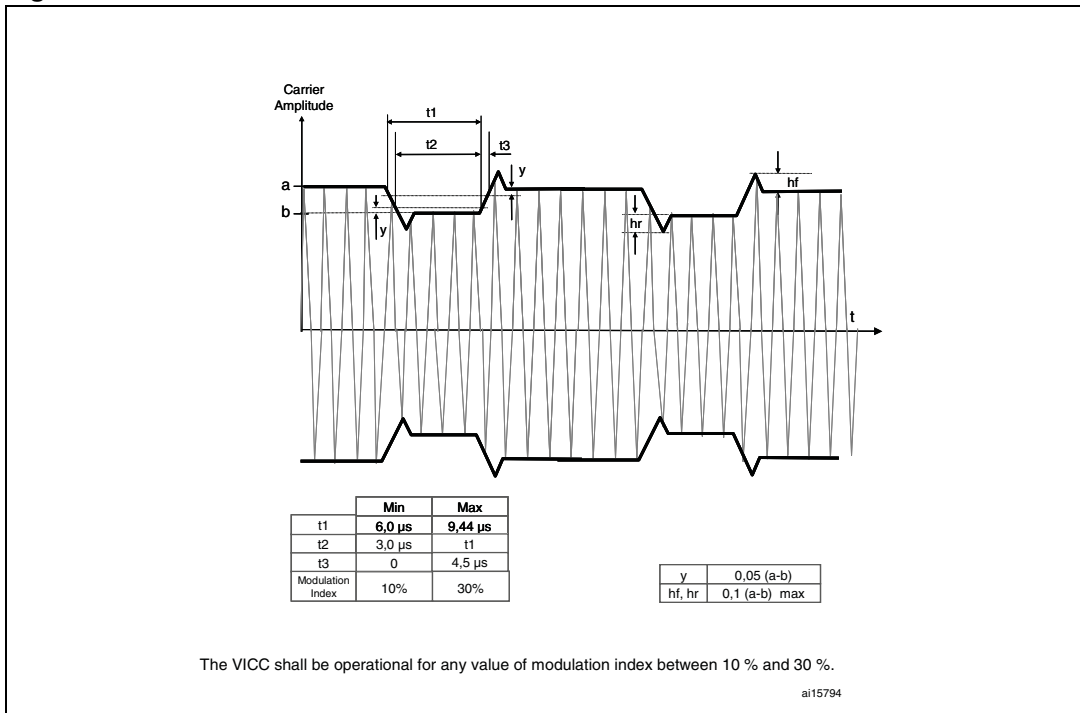

## 7 Data rate and data coding

The data coding implemented in the LRIS64K uses pulse position modulation. Both data coding modes that are described in the ISO/IEC15693 are supported by the LRIS64K. The selection is made by the VCD and indicated to the LRIS64K within the start of frame (SOF).

### 7.1 Data coding mode: 1 out of 256

The value of one single byte is represented by the position of one pause. The position of the pause on 1 of 256 successive time periods of 18.88  $\mu\text{s}$  ( $256/f_C$ ), determines the value of the byte. In this case the transmission of one byte takes 4.833 ms and the resulting data rate is 1.65 kbits/s ( $f_C/8192$ ).

*Figure 5* illustrates this pulse position modulation technique. In this figure, data E1h (225 decimal) is sent by the VCD to the LRIS64K.

The pause occurs during the second half of the position of the time period that determines the value, as shown in *Figure 6*.

A pause during the first period transmits the data value 00h. A pause during the last period transmit the data value FFh (255 decimal).

**Figure 5. 1 out of 256 coding mode**

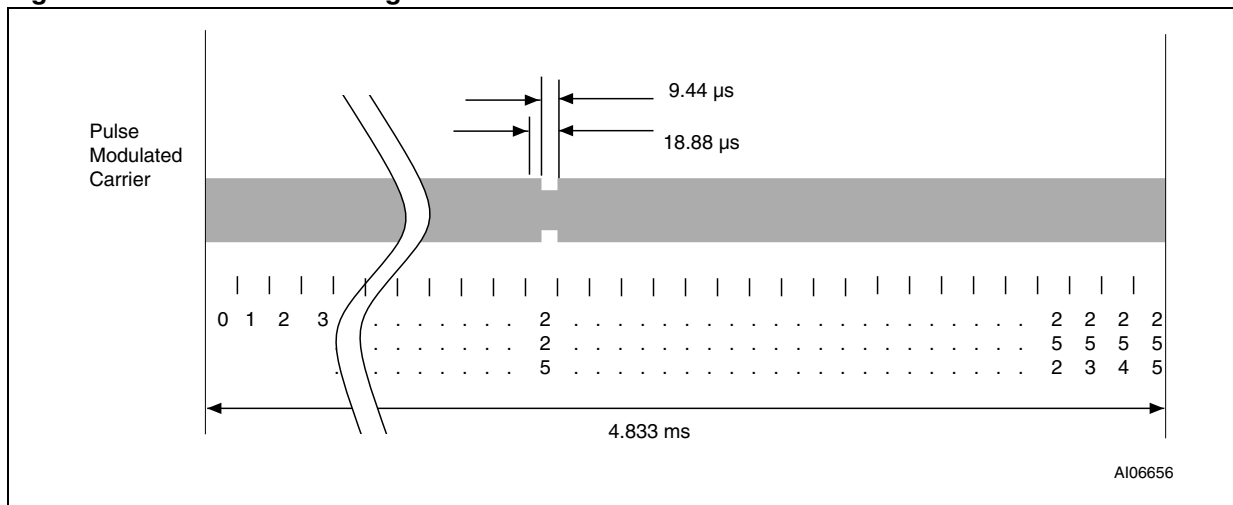
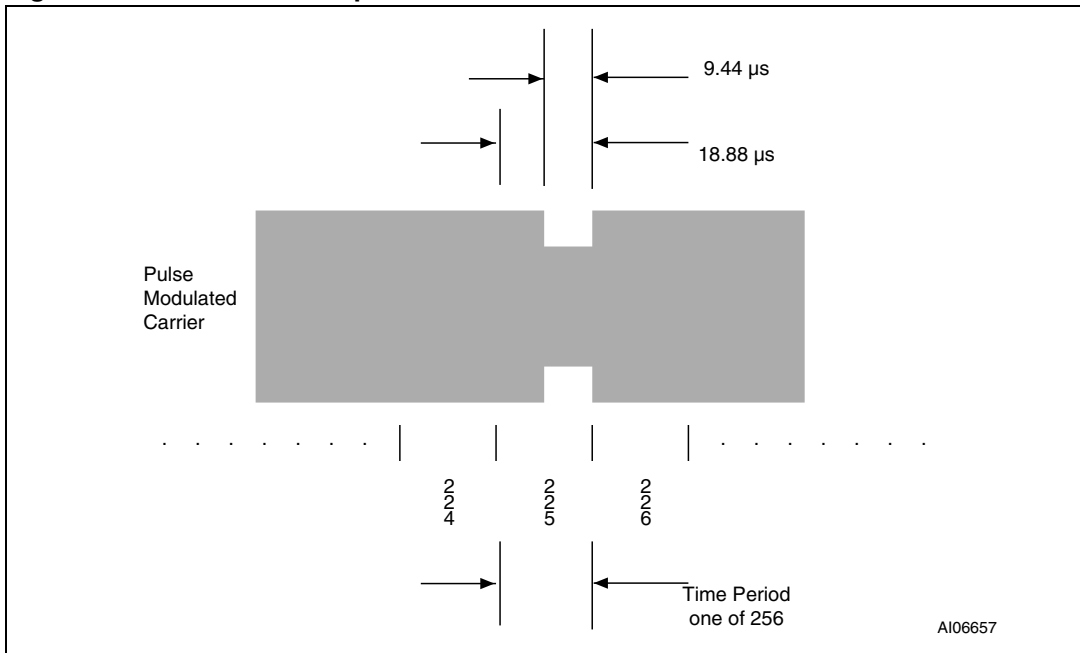

Figure 6. Detail of a time period



## 7.2 Data coding mode: 1 out of 4

The value of 2 bits is represented by the position of one pause. The position of the pause on 1 of 4 successive time periods of 18.88  $\mu\text{s}$  ( $256/f_C$ ), determines the value of the 2 bits. Four successive pairs of bits form a byte, where the least significant pair of bits is transmitted first.

In this case the transmission of one byte takes 302.08  $\mu\text{s}$  and the resulting data rate is 26.48 Kbits/s ( $f_C/512$ ). [Figure 7](#) illustrates the 1 out of 4 pulse position technique and coding. [Figure 8](#) shows the transmission of E1h (225d - 1110 0001b) by the VCD.

Figure 7. 1 out of 4 coding mode

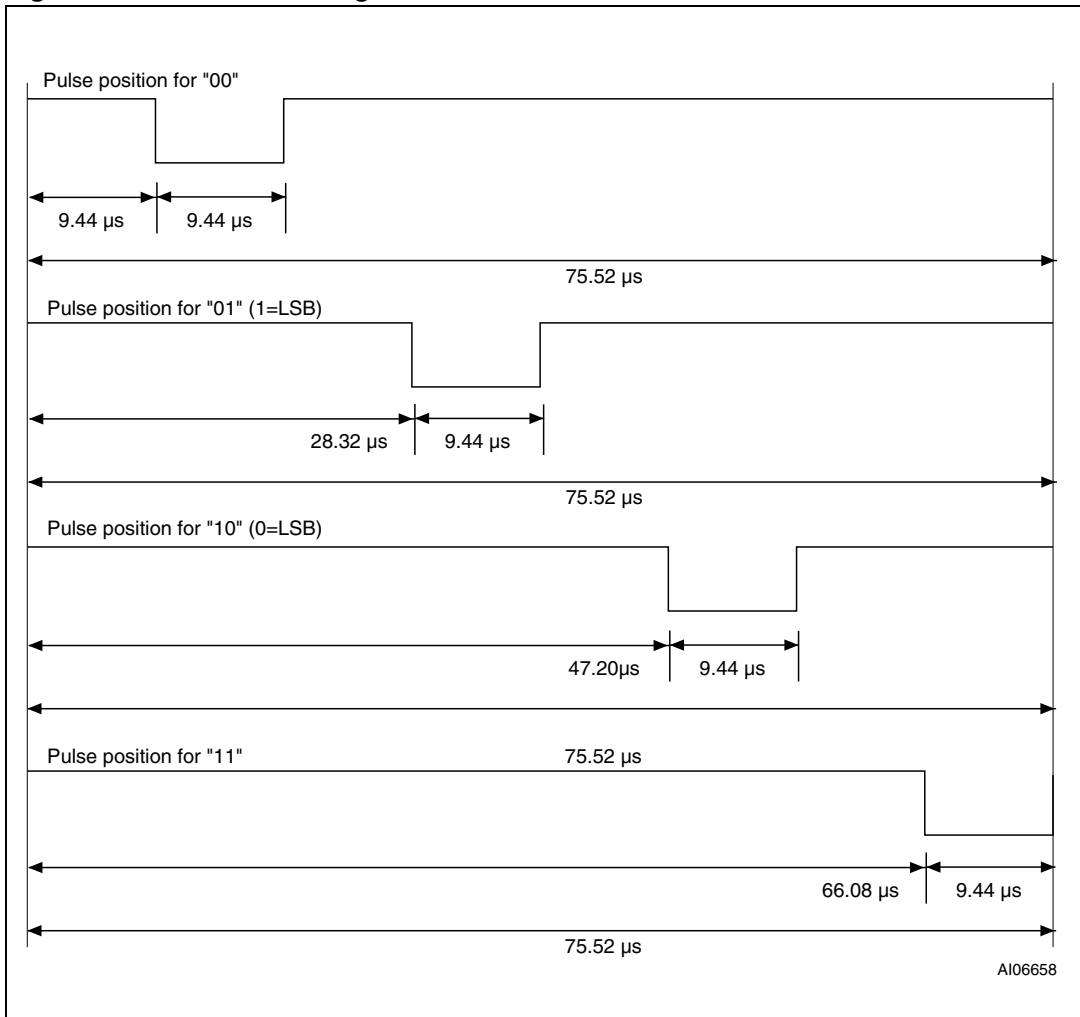
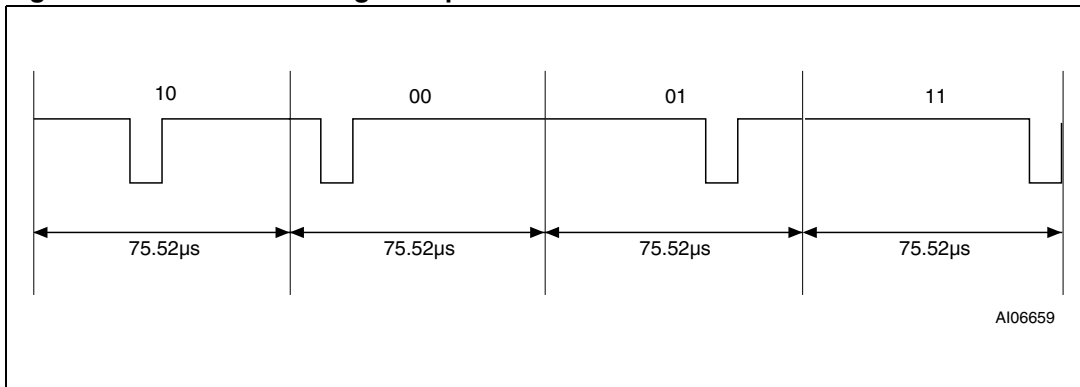

Figure 8. 1 out of 4 coding example



### 7.3 VCD to LRIS64K frames

Frames are delimited by a start of frame (SOF) and an end of frame (EOF). They are implemented using code violation. Unused options are reserved for future use.

The LRIS64K is ready to receive a new command frame from the VCD 311.5  $\mu\text{s}$  ( $t_2$ ) after sending a response frame to the VCD.

The LRIS64K takes a power-up time of 0.1 ms after being activated by the powering field. After this delay, the LRIS64K is ready to receive a command frame from the VCD.

### 7.4 Start of frame (SOF)

The SOF defines the data coding mode the VCD is to use for the following command frame. The SOF sequence described in *Figure 9* selects the 1 out of 256 data coding mode. The SOF sequence described in *Figure 10* selects the 1 out of 4 data coding mode. The EOF sequence for either coding mode is described in *Figure 11*.

**Figure 9. SOF to select 1 out of 256 data coding mode**

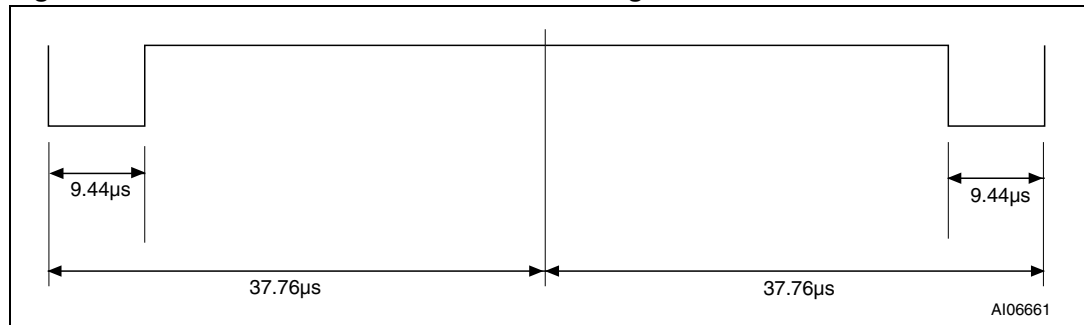

**Figure 10. SOF to select 1 out of 4 data coding mode**

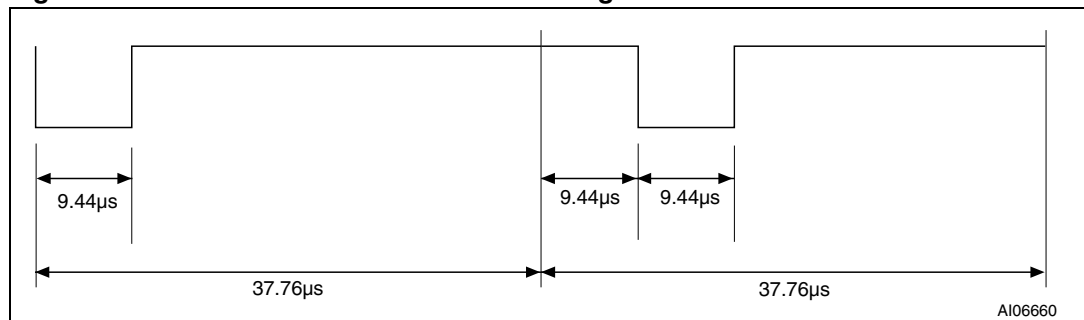

**Figure 11. EOF for either data coding mode**

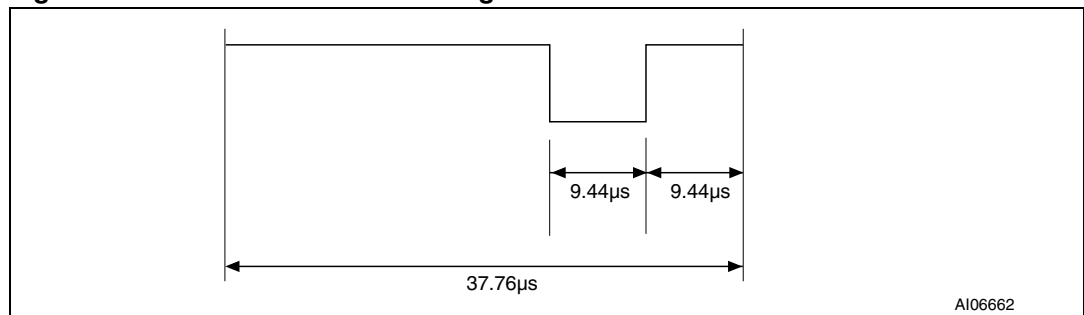

## 8 Communications signal from LRIS64K to VCD

The LRIS64K has several modes defined for some parameters, owing to which it can operate in different noise environments and meet different application requirements.

### 8.1 Load modulation

The LRIS64K is capable of communication to the VCD via an inductive coupling area whereby the carrier is loaded to generate a subcarrier with frequency  $f_S$ . The subcarrier is generated by switching a load in the LRIS64K.

The load-modulated amplitude received on the VCD antenna must be of at least 10mV when measured as described in the test methods defined in International Standard ISO/IEC10373-7.

### 8.2 Subcarrier

The LRIS64K supports the one-subcarrier and two-subcarrier response formats. These formats are selected by the VCD using the first bit in the protocol header. When one subcarrier is used, the frequency  $f_{S1}$  of the subcarrier load modulation is 423.75 kHz ( $f_C/32$ ). When two subcarriers are used, the frequency  $f_{S1}$  is 423.75 kHz ( $f_C/32$ ), and frequency  $f_{S2}$  is 484.28 kHz ( $f_C/28$ ). When using the two-subcarrier mode, the LRIS64K generates a continuous phase relationship between  $f_{S1}$  and  $f_{S2}$ .

### 8.3 Data rates

The LRIS64K can respond using the low or the high data rate format. The selection of the data rate is made by the VCD using the second bit in the protocol header. It also supports the x2 mode available on all the Fast commands. [Table 11](#) shows the different data rates produced by the LRIS64K using the different response format combinations.

**Table 11. Response data rates**

Data rate		One subcarrier	Two subcarriers
Low	Standard commands	6.62 Kbit/s ( $f_C/2048$ )	6.67 Kbit/s ( $f_C/2032$ )
	Fast commands	13.24 Kbit/s ( $f_C/1024$ )	not applicable
High	Standard commands	26.48 Kbit/s ( $f_C/512$ )	26.69 Kbit/s ( $f_C/508$ )
	Fast commands	52.97 Kbit/s ( $f_C/256$ )	not applicable

## 9 Bit representation and coding

Data bits are encoded using Manchester coding, according to the following schemes. For the low data rate, same subcarrier frequency or frequencies is/are used, in this case the number of pulses is multiplied by 4 and all times will increase by this factor. For the Fast commands using one subcarrier, all pulse numbers and times are divided by 2.

### 9.1 Bit coding using one subcarrier

#### 9.1.1 High data rate

A logic 0 starts with 8 pulses at 423.75 kHz ( $f_C/32$ ) followed by an unmodulated time of 18.88  $\mu s$  as shown in [Figure 12](#).

**Figure 12. Logic 0, high data rate, one subcarriers**

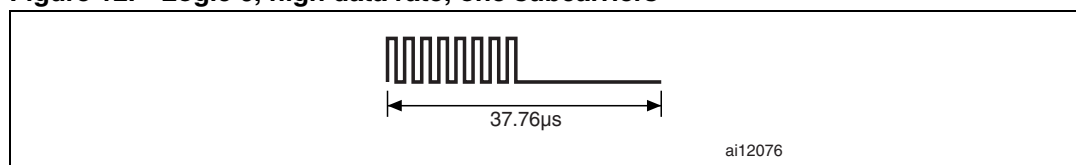

For the fast commands, a logic 0 starts with 4 pulses at 423.75 kHz ( $f_C/32$ ) followed by an unmodulated time of 9.44  $\mu s$  as shown in [Figure 13](#).

**Figure 13. Logic 0, high data rate, one subcarriers x2**

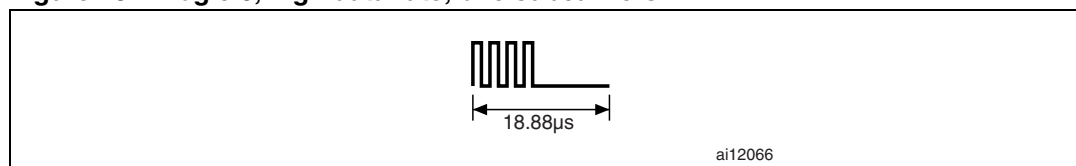

A logic 1 starts with an unmodulated time of 18.88  $\mu s$  followed by 8 pulses at 423.75 kHz ( $f_C/32$ ) as shown in [Figure 14](#).

**Figure 14. Logic 1, high data rate, one subcarriers**

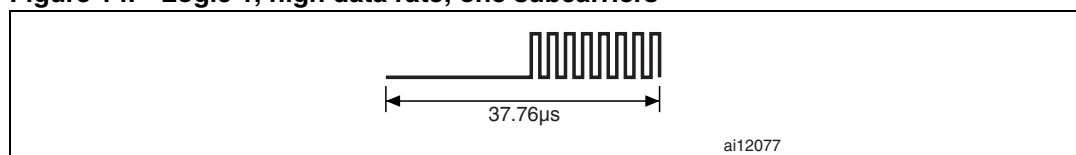

For the Fast commands, a logic 1 starts with an unmodulated time of 9.44  $\mu s$  followed by 4 pulses of 423.75 kHz ( $f_C/32$ ) as shown in [Figure 15](#).

**Figure 15. Logic 1, high data rate, one subcarriers x2**

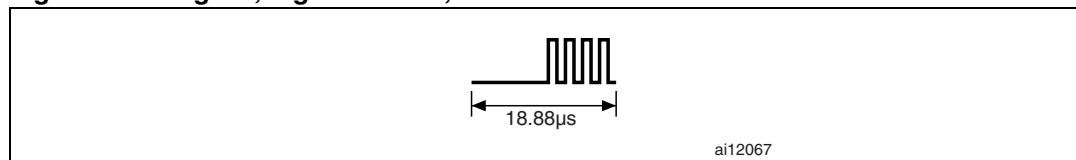

9.1.2 Low data rate

A logic 0 starts with 32 pulses at 423.75 kHz ( $f_C/32$ ) followed by an unmodulated time of 75.52  $\mu$ s as shown in [Figure 16](#).

Figure 16. Logic 0, low data rate, one subcarriers

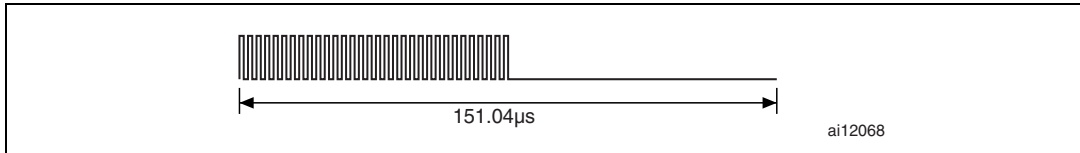

For the Fast commands, a logic 0 starts with 16 pulses at 423.75 kHz ( $f_C/32$ ) followed by an unmodulated time of 37.76  $\mu$ s as shown in [Figure 17](#).

Figure 17. Logic 0, low data rate, one subcarriers x2

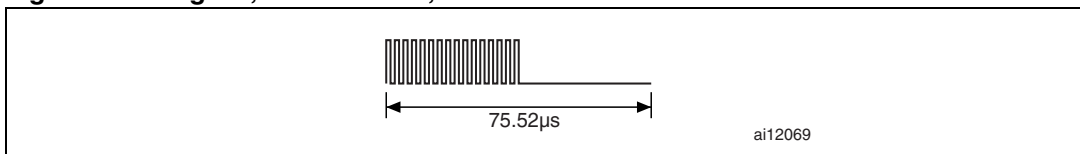

A logic 1 starts with an unmodulated time of 75.52  $\mu$ s followed by 32 pulses at 423.75 kHz ( $f_C/32$ ) as shown in [Figure 18](#).

Figure 18. Logic 1, low data rate, one subcarriers

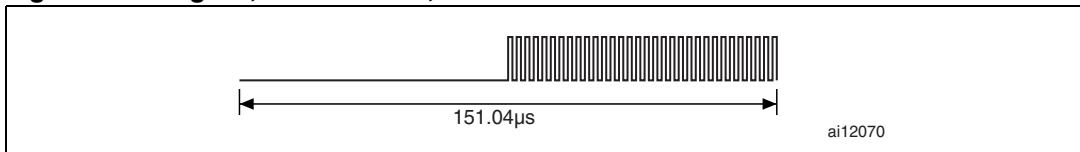

For the Fast commands, a logic 1 starts with an unmodulated time of 37.76  $\mu$ s followed by 16 pulses at 423.75 kHz ( $f_C/32$ ) as shown in [Figure 18](#).

Figure 19. Logic 1, low data rate, one subcarriers x2

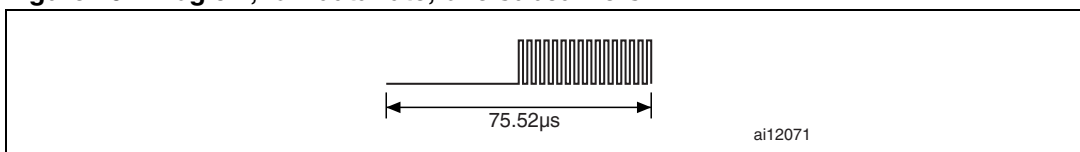

## 9.2 Bit coding using two subcarriers

### 9.3 High data rate

A logic 0 starts with 8 pulses at 423.75 kHz ( $f_C/32$ ) followed by 9 pulses at 484.28 kHz ( $f_C/28$ ) as shown in [Figure 20](#). For the Fast commands, the x2 mode is not available.

**Figure 20. Logic 0, high data rate, two subcarriers**

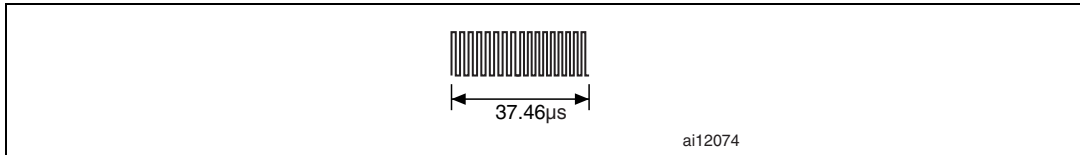

A logic 1 starts with 9 pulses at 484.28 kHz ( $f_C/28$ ) followed by 8 pulses at 423.75 kHz ( $f_C/32$ ) as shown in [Figure 21](#). For the Fast commands, the x2 mode is not available.

**Figure 21. Logic 1, high data rate, two subcarriers**

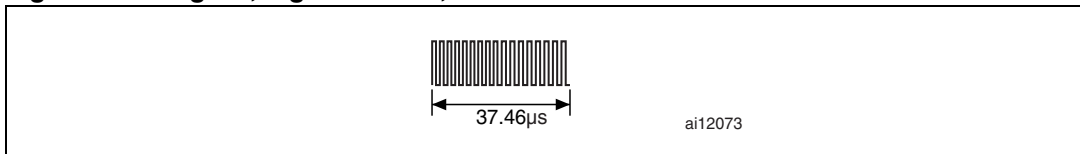

### 9.4 Low data rate

A logic 0 starts with 32 pulses at 423.75 kHz ( $f_C/32$ ) followed by 36 pulses at 484.28 kHz ( $f_C/28$ ) as shown in [Figure 22](#). For the Fast commands, the x2 mode is not available.

**Figure 22. Logic 0, low data rate, two subcarriers**

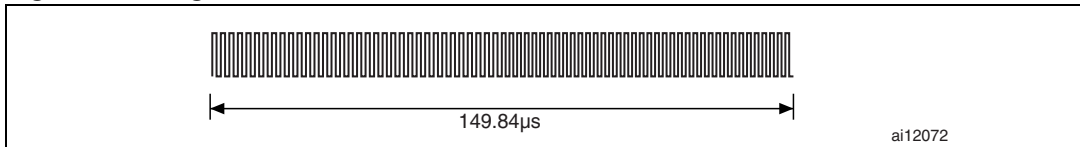

A logic 1 starts with 36 pulses at 484.28 kHz ( $f_C/28$ ) followed by 32 pulses at 423.75 kHz ( $f_C/32$ ) as shown in [Figure 23](#). For the Fast commands, the x2 mode is not available.

**Figure 23. Logic 1, low data rate, two subcarriers**

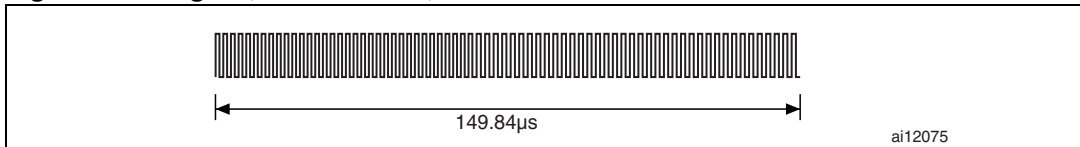

## 10 LRIS64K to VCD frames

Frames are delimited by an SOF and an EOF. They are implemented using code violation. Unused options are reserved for future use. For the low data rate, the same subcarrier frequency or frequencies is/are used. In this case the number of pulses is multiplied by 4. For the Fast commands using one subcarrier, all pulse numbers and times are divided by 2.

### 10.1 SOF when using one subcarrier

### 10.2 High data rate

The SOF includes an unmodulated time of 56.64  $\mu\text{s}$ , followed by 24 pulses at 423.75 kHz ( $f_C/32$ ), and a logic 1 that consists of an unmodulated time of 18.88  $\mu\text{s}$  followed by 8 pulses at 423.75 kHz as shown in [Figure 24](#).

**Figure 24. Start of frame, high data rate, one subcarrier**

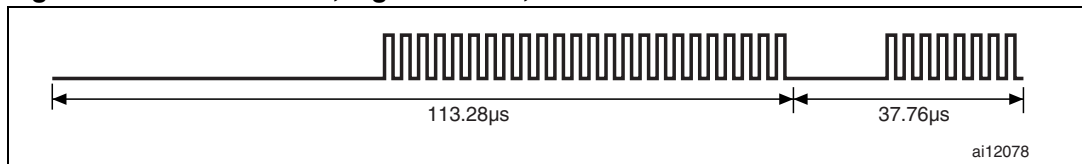

For the Fast commands, the SOF comprises an unmodulated time of 28.32  $\mu\text{s}$ , followed by 12 pulses at 423.75 kHz ( $f_C/32$ ), and a logic 1 that consists of an unmodulated time of 9.44  $\mu\text{s}$  followed by 4 pulses at 423.75 kHz as shown in [Figure 25](#).

**Figure 25. Start of frame, high data rate, one subcarrier x2**



### 10.3 Low data rate

The SOF comprises an unmodulated time of 226.56  $\mu\text{s}$ , followed by 96 pulses at 423.75 kHz ( $f_C/32$ ), and a logic 1 that consists of an unmodulated time of 75.52  $\mu\text{s}$  followed by 32 pulses at 423.75 kHz as shown in [Figure 26](#).

**Figure 26. Start of frame, low data rate, one subcarrier**

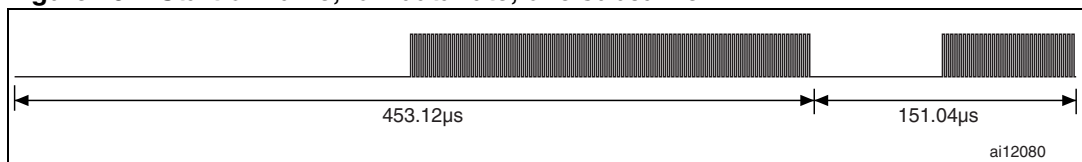

For the Fast commands, the SOF comprises an unmodulated time of 113.28  $\mu\text{s}$ , followed by 48 pulses at 423.75 kHz ( $f_C/32$ ), and a logic 1 that includes an unmodulated time of 37.76  $\mu\text{s}$  followed by 16 pulses at 423.75 kHz as shown in [Figure 27](#).

**Figure 27. Start of frame, low data rate, one subcarrier x2**

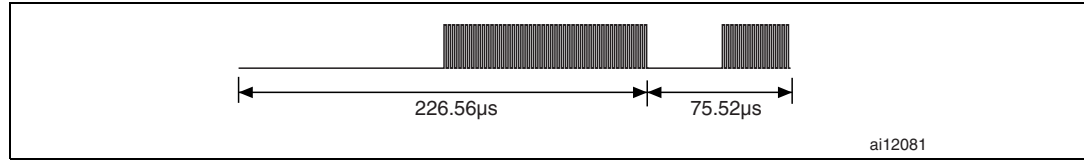

## 10.4 SOF when using two subcarriers

## 10.5 High data rate

The SOF comprises 27 pulses at 484.28 kHz ( $f_C/28$ ), followed by 24 pulses at 423.75 kHz ( $f_C/32$ ), and a logic 1 that includes 9 pulses at 484.28 kHz followed by 8 pulses at 423.75 kHz as shown in [Figure 28](#).

For the Fast commands, the x2 mode is not available.

**Figure 28. Start of frame, high data rate, two subcarriers**

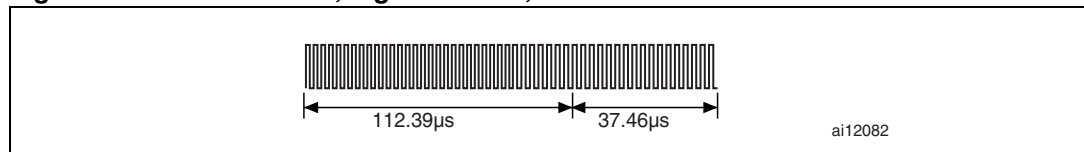

## 10.6 Low data rate

The SOF comprises 108 pulses at 484.28 kHz ( $f_C/28$ ), followed by 96 pulses at 423.75 kHz ( $f_C/32$ ), and a logic 1 that includes 36 pulses at 484.28 kHz followed by 32 pulses at 423.75 kHz as shown in [Figure 29](#).

For the Fast commands, the x2 mode is not available.

**Figure 29. Start of frame, low data rate, two subcarriers**

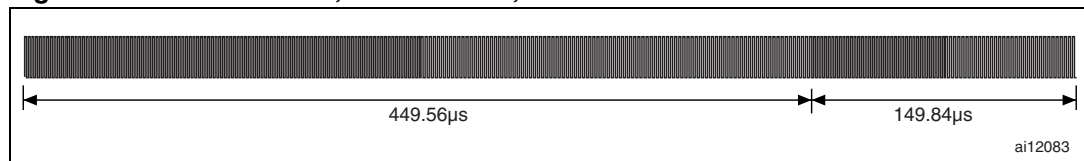

### 10.7 EOF when using one subcarrier

### 10.8 High data rate

The EOF comprises a logic 0 that includes 8 pulses at 423.75 kHz and an unmodulated time of 18.88  $\mu$ s, followed by 24 pulses at 423.75 kHz ( $f_C/32$ ), and by an unmodulated time of 56.64  $\mu$ s as shown in [Figure 30](#).

**Figure 30. End of frame, high data rate, one subcarriers**

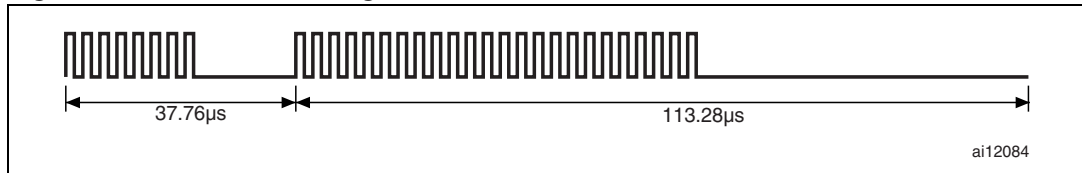

For the Fast commands, the EOF comprises a logic 0 that includes 4 pulses at 423.75 kHz and an unmodulated time of 9.44  $\mu$ s, followed by 12 pulses at 423.75 kHz ( $f_C/32$ ) and an unmodulated time of 37.76  $\mu$ s as shown in [Figure 31](#).

**Figure 31. End of frame, high data rate, one subcarriers x2**

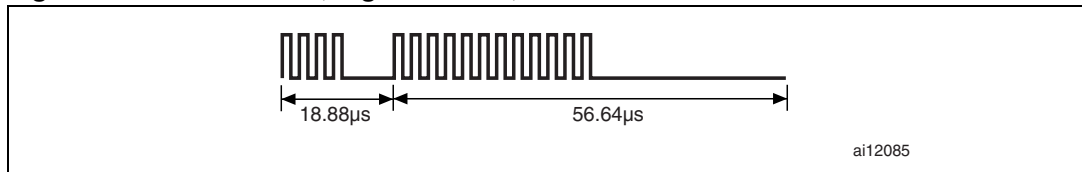

### 10.9 Low data rate

The EOF comprises a logic 0 that includes 32 pulses at 423.75 kHz and an unmodulated time of 75.52  $\mu$ s, followed by 96 pulses at 423.75 kHz ( $f_C/32$ ) and an unmodulated time of 226.56  $\mu$ s as shown in [Figure 32](#).

**Figure 32. End of frame, low data rate, one subcarriers**

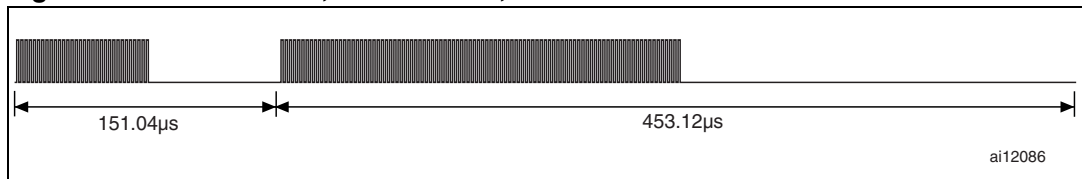

For the Fast commands, the EOF comprises a logic 0 that includes 16 pulses at 423.75 kHz and an unmodulated time of 37.76  $\mu$ s, followed by 48 pulses at 423.75 kHz ( $f_C/32$ ) and an unmodulated time of 113.28  $\mu$ s as shown in [Figure 33](#).

**Figure 33. End of frame, low data rate, one subcarriers x2**

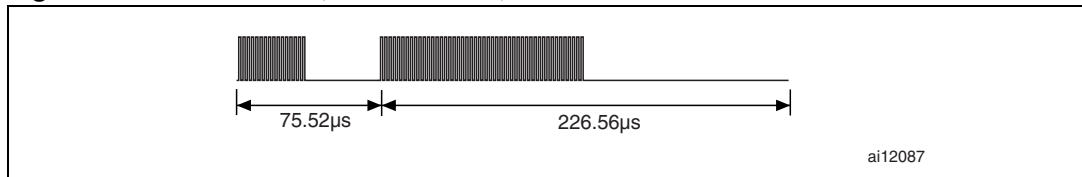

### 10.10 EOF when using two subcarriers

### 10.11 High data rate

The EOF comprises a logic 0 that includes 8 pulses at 423.75 kHz and 9 pulses at 484.28 kHz, followed by 24 pulses at 423.75 kHz ( $f_c/32$ ) and 27 pulses at 484.28 kHz ( $f_c/28$ ) as shown in [Figure 34](#).

For the Fast commands, the x2 mode is not available.

**Figure 34. End of frame, high data rate, two subcarriers**

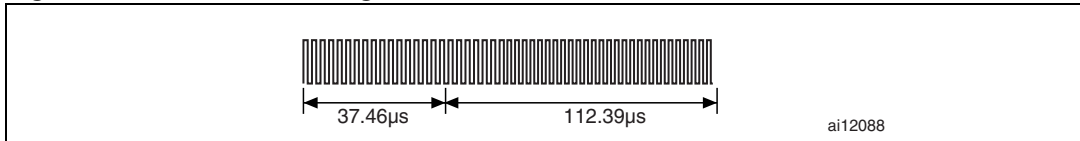

### 10.12 Low data rate

The EOF comprises a logic 0 that includes 32 pulses at 423.75 kHz and 36 pulses at 484.28 kHz, followed by 96 pulses at 423.75 kHz ( $f_c/32$ ) and 108 pulses at 484.28 kHz ( $f_c/28$ ) as shown in [Figure 35](#).

For the Fast commands, the x2 mode is not available.

**Figure 35. End of frame, low data rate, two subcarriers**

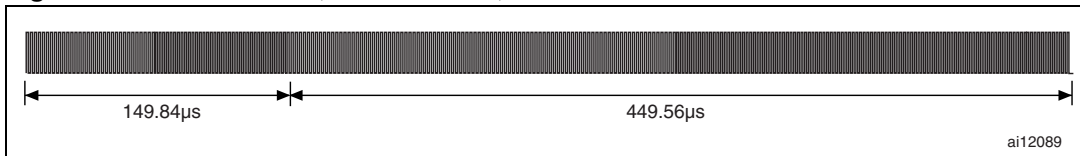

## 11 Unique identifier (UID)

The LRIS64K is uniquely identified by a 64-bit Unique Identifier (UID). This UID complies with ISO/IEC 15963 and ISO/IEC 7816-6. The UID is a read-only code and comprises:

- 8 MSBs with a value of E0h
- The IC Manufacturer code of ST 02h, on 8 bits (ISO/IEC 7816-6/AM1)
- a Unique Serial Number on 48 bits

**Table 12. UID format**

MSB		LSB	
63	56	55	47
0xE0		0x02	
Unique serial number			

With the UID each LRIS64K can be addressed uniquely and individually during the anticollision loop and for one-to-one exchanges between a VCD and an LRIS64K.

## 12 Application family identifier (AFI)

The AFI (application family identifier) represents the type of application targeted by the VCD and is used to identify, among all the LRIS64Ks present, only the LRIS64Ks that meet the required application criteria.

Figure 36. LRIS64K decision tree for AFI

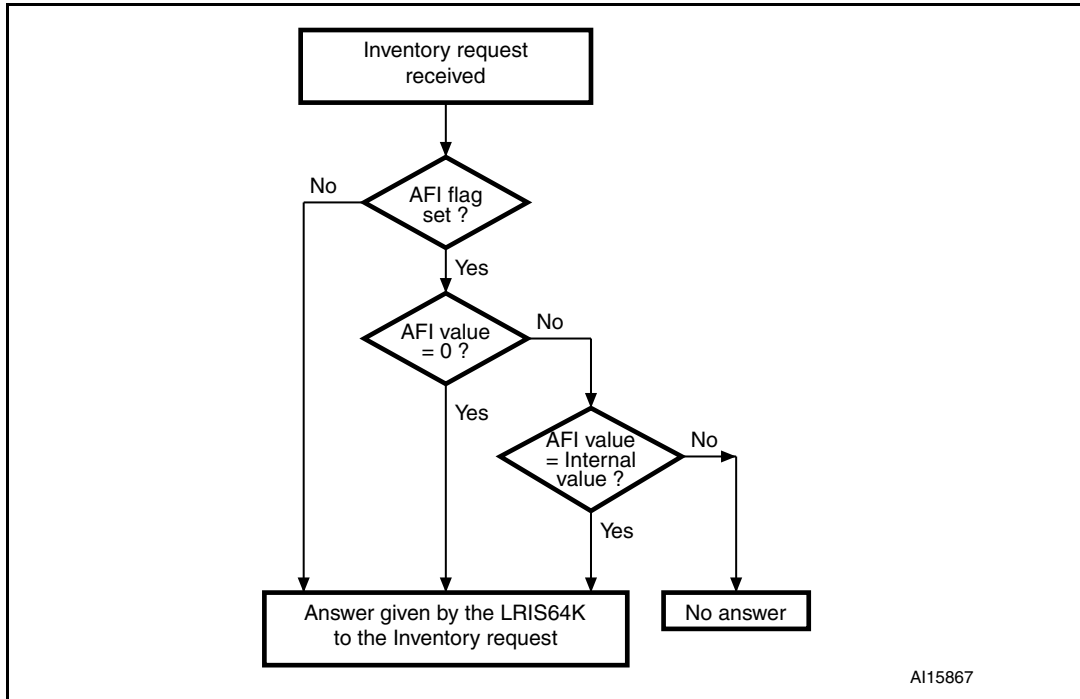

The AFI is programmed by the LRIS64K issuer (or purchaser) in the AFI register. Once programmed and Locked, it can no longer be modified.

The most significant nibble of the AFI is used to code one specific or all application families.

The least significant nibble of the AFI is used to code one specific or all application subfamilies. Subfamily codes different from 0 are proprietary.

(See ISO/IEC 15693-3 documentation)

## 13 Data storage format identifier (DSFID)

The data storage format identifier indicates how the data is structured in the LRIS64K memory. The logical organization of data can be known instantly using the DSFID. It can be programmed and locked using the Write DSFID and Lock DSFID commands.

### 13.1 CRC

The CRC used in the LRIS64K is calculated as per the definition in ISO/IEC 13239. The initial register contents are all ones: "FFFF".

The two-byte CRC are appended to each request and response, within each frame, before the EOF. The CRC is calculated on all the bytes after the SOF up to the CRC field.

Upon reception of a request from the VCD, the LRIS64K verifies that the CRC value is valid. If it is invalid, the LRIS64K discards the frame and does not answer to the VCD.

Upon reception of a Response from the LRIS64K, it is recommended that the VCD verifies whether the CRC value is valid. If it is invalid, actions to be performed are left to the discretion of the VCD designer.

The CRC is transmitted least significant byte first. Each byte is transmitted least significant bit first.

**Table 13. CRC transmission rules**

LSByte		MSByte	
LSBit	MSBit	LSBit	MSBit
CRC 16 (8 bits)		CRC 16 (8 bits)	

## 14 LRIS64K protocol description

The transmission protocol (or simply protocol) defines the mechanism used to exchange instructions and data between the VCD and the LRIS64K, in both directions. It is based on the concept of “VCD talks first”.

This means that an LRIS64K will not start transmitting unless it has received and properly decoded an instruction sent by the VCD. The protocol is based on an exchange of:

- a request from the VCD to the LRIS64K
- a response from the LRIS64K to the VCD

Each request and each response are contained in a frame. The frame delimiters (SOF, EOF) are described in [Section 10: LRIS64K to VCD frames](#).

Each request consists of:

- a request SOF (see [Figure 9](#) and [Figure 10](#))
- flags
- a command code
- parameters, depending on the command
- application data
- a 2-byte CRC
- a request EOF (see [Figure 11](#))

Each response consists of:

- an answer SOF (see [Figure 24](#) to [Figure 29](#))
- flags
- parameters, depending on the command
- application data
- a 2-byte CRC
- an answer EOF (see [Figure 30](#) to [Figure 35](#))

The protocol is bit-oriented. The number of bits transmitted in a frame is a multiple of eight (8), that is an integer number of bytes.

A single-byte field is transmitted least significant bit (LSBit) first. A multiple-byte field is transmitted least significant byte (LSByte) first, each byte is transmitted least significant bit (LSBit) first.

The setting of the flags indicates the presence of the optional fields. When the flag is set (to one), the field is present. When the flag is reset (to zero), the field is absent.

**Table 14. VCD request frame format**

Request SOF	Request_flags	Command code	Parameters	Data	2-byte CRC	Request EOF
-------------	---------------	--------------	------------	------	------------	-------------

**Table 15. LRIS64K Response frame format**

Response SOF	Response_flags	Parameters	Data	2-byte CRC	Response EOF
--------------	----------------	------------	------	------------	--------------

Figure 37. LRIS64K protocol timing

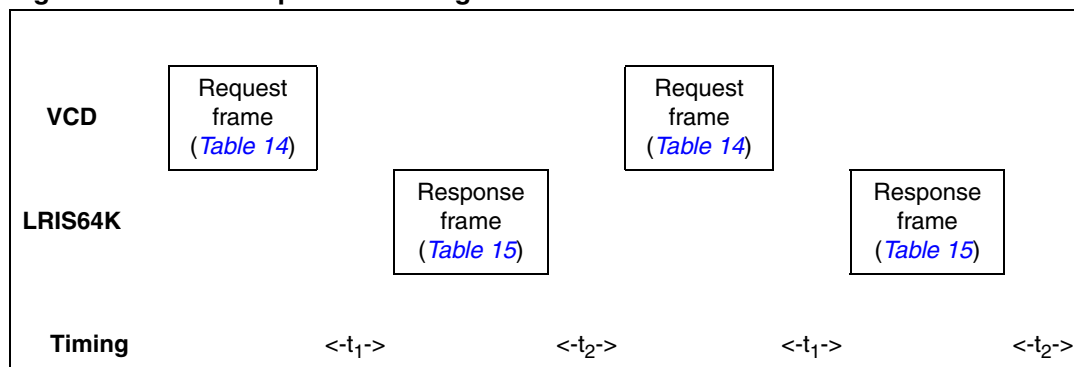

## 15 LRIS64K states

An LRIS64K can be in one of 4 states:

- Power-off
- Ready
- Quiet
- Selected

Transitions between these states are specified in [Figure 38: LRIS64K state transition diagram](#) and [Table 16: LRIS64K response depending on Request\\_flags](#).

### 15.1 Power-off state

The LRIS64K is in the Power-off state when it does not receive enough energy from the VCD.

### 15.2 Ready state

The LRIS64K is in the Ready state when it receives enough energy from the VCD. When in the Ready state, the LRIS64K answers any request where the Select\_flag is not set.

### 15.3 Quiet state

When in the Quiet state, the LRIS64K answers any request except for Inventory requests with the Address\_flag set.

### 15.4 Selected state

In the Selected state, the LRIS64K answers any request in all modes (see [Section 16: Modes](#)):

- Request in Select mode with the Select\_flag set
- Request in Addressed mode if the UID matches
- Request in Non-Addressed mode as it is the mode for general requests

**Table 16. LRIS64K response depending on Request\_flags**

Flags	Address_flag		Select_flag	
	1 Addressed	0 Non addressed	1 Selected	0 Non selected
LRIS64K in Ready or Selected state (Devices in Quiet state do not answer)		X		X
LRIS64K in Selected state		X	X	
LRIS64K in Ready, Quiet or Selected state (the device which matches the UID)	X			X
Error (03h)	X		X	

**Figure 38. LRIS64K state transition diagram**

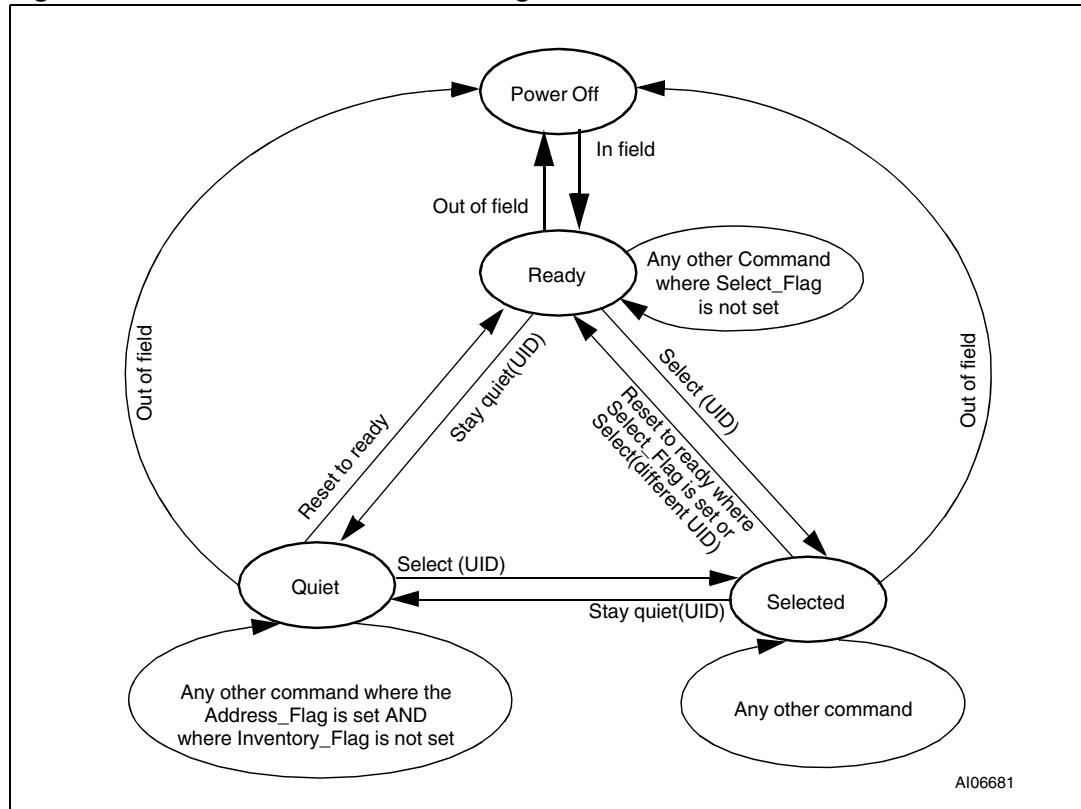

1. The intention of the state transition method is that only one LRIS64K should be in the selected state at a time.

## 16 Modes

The term “mode” refers to the mechanism used in a request to specify the set of LRIS64Ks that will answer the request.

### 16.1 Addressed mode

When the `Address_flag` is set to 1 (Addressed mode), the request contains the Unique ID (UID) of the addressed LRIS64K.

Any LRIS64K that receives a request with the `Address_flag` set to 1 compares the received Unique ID to its own. If it matches, then the LRIS64K executes the request (if possible) and returns a response to the VCD as specified in the command description.

If the UID does not match, then it remains silent.

### 16.2 Non-addressed mode (general request)

When the `Address_flag` is cleared to 0 (Non-Addressed mode), the request does not contain a Unique ID. Any LRIS64K receiving a request with the `Address_flag` cleared to 0 executes it and returns a response to the VCD as specified in the command description.

### 16.3 Select mode

When the `Select_flag` is set to 1 (Select mode), the request does not contain an LRIS64K Unique ID. The LRIS64K in the Selected state that receives a request with the `Select_flag` set to 1 executes it and returns a response to the VCD as specified in the command description.

Only LRIS64Ks in the Selected state answer a request where the `Select_flag` set to 1.

The system design ensures in theory that only one LRIS64K can be in the Select state at a time.

## 17 Request format

The request consists of:

- an SOF
- flags
- a command code
- parameters and data
- a CRC
- an EOF

**Table 17. General request format**

S O F	Request_flags	Command code	Parameters	Data	CRC	E O F
-------------	---------------	--------------	------------	------	-----	-------------

### 17.1 Request flags

In a request, the “flags” field specifies the actions to be performed by the LRIS64K and whether corresponding fields are present or not.

The flags field consists of eight bits. The bit 3 (Inventory\_flag) of the request flag defines the contents of the 4 MSBs (bits 5 to 8). When bit 3 is reset (0), bits 5 to 8 define the LRIS64K selection criteria. When bit 3 is set (1), bits 5 to 8 define the LRIS64K Inventory parameters.

**Table 18. Definition of request flags 1 to 4**

Bit No	Flag	Level	Description
Bit 1	Subcarrier_flag <sup>(1)</sup>	0	A single subcarrier frequency is used by the LRIS64K
		1	Two subcarrier are used by the LRIS64K
Bit 2	Data_rate_flag <sup>(2)</sup>	0	Low data rate is used
		1	High data rate is used
Bit 3	Inventory_flag	0	The meaning of flags 5 to 8 is described in <a href="#">Table 19</a>
		1	The meaning of flags 5 to 8 is described in <a href="#">Table 20</a>
Bit 4	Protocol_extension_flag	0	No Protocol format extension
		1	Protocol format extension

1. Subcarrier\_flag refers to the LRIS64K-to-VCD communication.

2. Data\_rate\_flag refers to the LRIS64K-to-VCD communication

**Table 19. Request flags 5 to 8 when Bit 3 = 0**

Bit No	Flag	Level	Description
Bit 5	Select flag <sup>(1)</sup>	0	Request is executed by any LRIS64K according to the setting of Address_flag
		1	Request is executed only by the LRIS64K in Selected state
Bit 6	Address flag <sup>(1)</sup>	0	Request is not addressed. UID field is not present. The request is executed by all LRIS64Ks.
		1	Request is addressed. UID field is present. The request is executed only by the LRIS64K whose UID matches the UID specified in the request.
Bit 7	Option flag	0	Option not activated.
		1	Option activated.
Bit 8	RFU	0	

1. If the Select\_flag is set to 1, the Address\_flag is set to 0 and the UID field is not present in the request.

**Table 20. Request flags 5 to 8 when Bit 3 = 1**

Bit No	Flag	Level	Description
Bit 5	AFI flag	0	AFI field is not present
		1	AFI field is present
Bit 6	Nb_slots flag	0	16 slots
		1	1 slot
Bit 7	Option flag	0	
Bit 8	RFU	0	

## 18 Response format

The response consists of:

- an SOF
- flags
- parameters and data
- a CRC
- an EOF

**Table 21. General response format**

S O F	Response_flags	Parameters	Data	CRC	E O F
-------------	----------------	------------	------	-----	-------------

### 18.1 Response flags

In a response, the flags indicate how actions have been performed by the LRIS64K and whether corresponding fields are present or not. The response flags consist of eight bits.

**Table 22. Definitions of response flags 1 to 8**

Bit No	Flag	Level	Description
Bit 1	Error_flag	0	No error
		1	Error detected. Error code is in the "Error" field.
Bit 2	RFU	0	
Bit 3	RFU	0	
Bit 4	Extension flag	0	No extension
Bit 5	RFU	0	
Bit 6	RFU	0	
Bit 7	RFU	0	
Bit 8	RFU	0	

## 18.2 Response error code

If the Error\_flag is set by the LRIS64K in the response, the Error code field is present and provides information about the error that occurred.

Error codes not specified in [Table 23](#) are reserved for future use.

**Table 23. Response error code definition**

Error code	Meaning
02h	The command is not recognized, for example a format error occurred
03h	The option is not supported
0Fh	Error with no information given
10h	The specified block is not available
11h	The specified block is already locked and thus cannot be locked again
12h	The specified block is locked and its contents cannot be changed.
13h	The specified block was not successfully programmed
14h	The specified block was not successfully locked
15h	The specified block is read-protected

## 19 Anticollision

The purpose of the anticollision sequence is to inventory the LRIS64Ks present in the VCD field using their unique ID (UID).

The VCD is the master of communications with one or several LRIS64Ks. It initiates LRIS64K communication by issuing the Inventory request.

The LRIS64K sends its response in the determined slot or does not respond.

### 19.1 Request parameters

When issuing the Inventory Command, the VCD:

- sets the Nb\_slots\_flag as desired
- adds the mask length and the mask value after the command field
- The mask length is the number of significant bits of the mask value.
- The mask value is contained in an integer number of bytes. The mask length indicates the number of significant bits. LSB is transmitted first
- If the mask length is not a multiple of 8 (bits), as many 0-bits as required will be added to the mask value MSB so that the mask value is contained in an integer number of bytes
- The next field starts at the next byte boundary.

**Table 24. Inventory request format**

MSB SOF	Request _flags	Command	Optional AFI <sup>(1)</sup>	Mask length	Mask value	CRC	LSB EOF
	8 bits	8 bits	8 bits	8 bits	0 to 8 bytes	16 bits	

1. Gray means that the field is optional.

In the example of the [Table 25](#) and [Figure 39](#), the mask length is 11 bits. Five 0-bits are added to the mask value MSB. The 11-bit Mask and the current slot number are compared to the UID.

**Table 25. Example of the addition of 0-bits to an 11-bit mask value**

(b <sub>15</sub> ) MSB	LSB (b <sub>0</sub> )
0000 0	100 1100 1111
0-bits added	11-bit mask value



## 20 Request processing by the LRIS64K

Upon reception of a valid request, the LRIS64K performs the following algorithm:

- NbS is the total number of slots (1 or 16)
- SN is the current slot number (0 to 15)
- LSB (value, n) function returns the n Less Significant Bits of value
- MSB (value, n) function returns the n Most Significant Bits of value
- “&” is the concatenation operator
- Slot\_Frame is either an SOF or an EOF

```
SN = 0
if (Nb_slots_flag)
  then NbS = 1
       SN_length = 0
       endif
  else NbS = 16
       SN_length = 4
       endif

label1:
if LSB(UID, SN_length + Mask_length) =
  LSB(SN, SN_length) & LSB(Mask, Mask_length)
  then answer to inventory request
  endif

wait (Slot_Frame)

if Slot_Frame = SOF
  then Stop Anticollision
       decode/process request
       exit
  endif

if Slot_Frame = EOF
  if SN < NbS-1
    then SN = SN + 1
         goto label1
         exit
    endif
  endif
```

## 21 Explanation of the possible cases

*Figure 40* summarizes the main possible cases that can occur during an anticollision sequence when the slot number is 16.

The different steps are:

- The VCD sends an Inventory request, in a frame terminated by an EOF. The number of slots is 16.
- LRIS64K\_1 transmits its response in Slot 0. It is the only one to do so, therefore no collision occurs and its UID is received and registered by the VCD;
- The VCD sends an EOF in order to switch to the next slot.
- In slot 1, two LRIS64Ks, LRIS64K\_2 and LRIS64K\_3 transmit a response, thus generating a collision. The VCD records the event and remembers that a collision was detected in Slot 1.
- The VCD sends an EOF in order to switch to the next slot.
- In Slot 2, no LRIS64K transmits a response. Therefore the VCD does not detect any LRIS64K SOF and decides to switch to the next slot by sending an EOF.
- In slot 3, there is another collision caused by responses from LRIS64K\_4 and LRIS64K\_5
- The VCD then decides to send a request (for instance a Read Block) to LRIS64K\_1 whose UID has already been correctly received.
- All LRIS64Ks detect an SOF and exit the anticollision sequence. They process this request and since the request is addressed to LRIS64K\_1, only LRIS64K\_1 transmits a response.
- All LRIS64Ks are ready to receive another request. If it is an Inventory command, the slot numbering sequence restarts from 0.

*Note:* *The decision to interrupt the anticollision sequence is made by the VCD. It could have continued to send EOFs until Slot 16 and only then sent the request to LRIS64K\_1.*

Figure 40. Description of a possible anticollision sequence

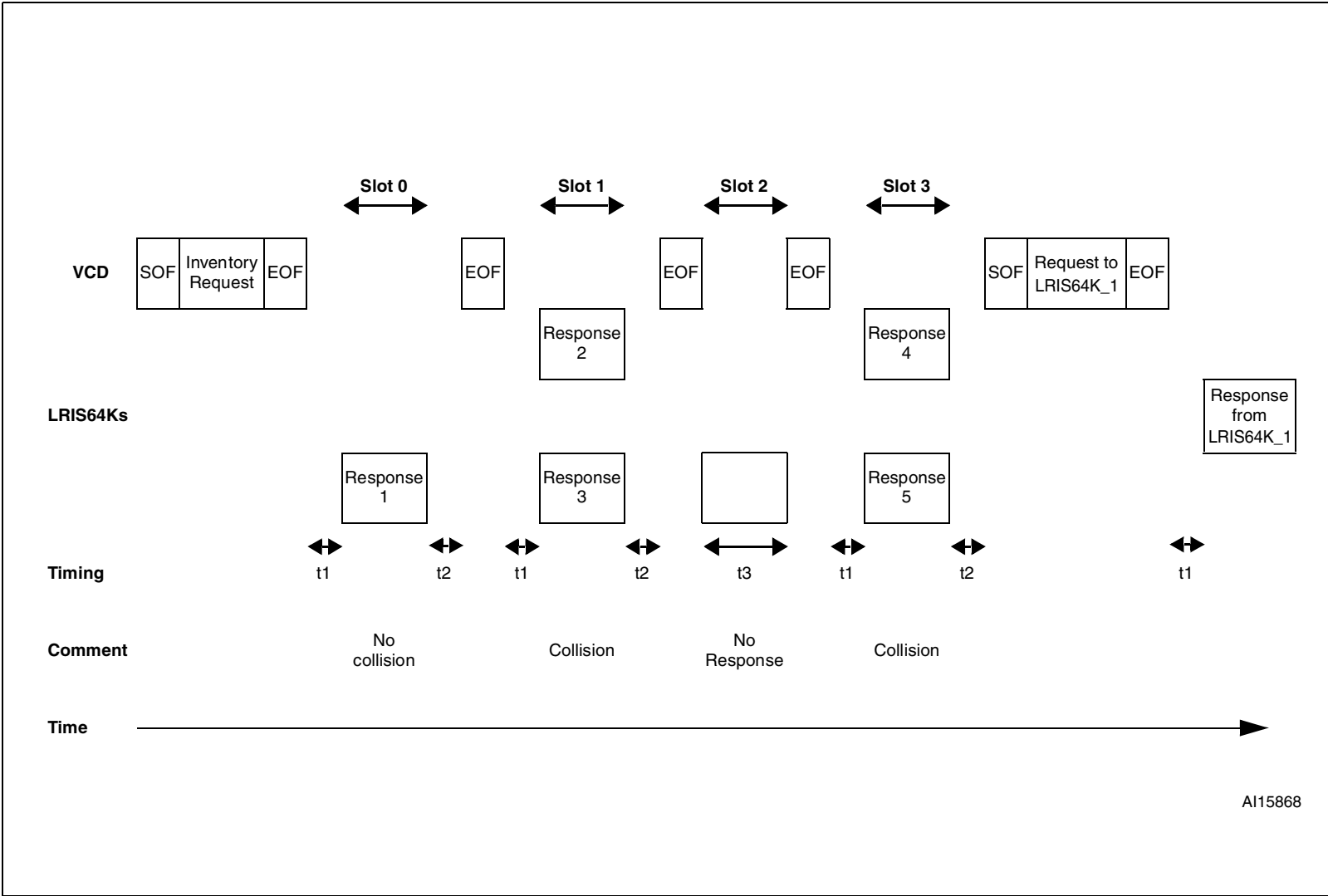

## 22 Inventory Initiated command

The LRIS64K provides a special feature to improve the inventory time response of moving tags using the `Initiate_flag` value. This flag, controlled by the `Initiate` command, allows tags to answer to `Inventory Initiated` commands.

For applications in which multiple tags are moving in front of a reader, it is possible to miss tags using the standard inventory command. The reason is that the inventory sequence has to be performed on a global tree search. For example, a tag with a particular UID value may have to wait the run of a long tree search before being inventoried. If the delay is too long, the tag may be out of the field before it has been detected.

Using the `Initiate` command, the inventory sequence is optimized. When multiple tags are moving in front of a reader, the ones which are within the reader field will be initiated by the `Initiate` command. In this case, a small batch of tags will answer to the `Inventory Initiated` command which will optimize the time necessary to identify all the tags. When finished, the reader has to issue a new `Initiate` command in order to initiate a new small batch of tags which are new inside the reader field.

It is also possible to reduce the inventory sequence time using the `Fast Initiate` and `Fast Inventory Initiated` commands. These commands allow the LRIS64Ks to increase their response data rate by a factor of 2, up to 53 Kbit/s.

## 23 Timing definition

### 23.1 $t_1$ : LRIS64K response delay

Upon detection of the rising edge of the EOF received from the VCD, the LRIS64K waits for a time  $t_{1nom}$  before transmitting its response to a VCD request or before switching to the next slot during an inventory process. Values of  $t_1$  are given in [Table 26](#). The EOF is defined in [Figure 11 on page 26](#).

### 23.2 $t_2$ : VCD new request delay

$t_2$  is the time after which the VCD may send an EOF to switch to the next slot when one or more LRIS64K responses have been received during an Inventory command. It starts from the reception of the EOF from the LRIS64Ks.

The EOF sent by the VCD may be either 10% or 100% modulated regardless of the modulation index used for transmitting the VCD request to the LRIS64K.

$t_2$  is also the time after which the VCD may send a new request to the LRIS64K as described in [Table 37: LRIS64K protocol timing](#).

Values of  $t_2$  are given in [Table 26](#).

### 23.3 $t_3$ : VCD new request delay in the absence of a response from the LRIS64K

$t_3$  is the time after which the VCD may send an EOF to switch to the next slot when no LRIS64K response has been received.

The EOF sent by the VCD may be either 10% or 100% modulated regardless of the modulation index used for transmitting the VCD request to the LRIS64K.

From the time the VCD has generated the rising edge of an EOF:

- If this EOF is 100% modulated, the VCD waits a time at least equal to  $t_{3min}$  before sending a new EOF.
- If this EOF is 10% modulated, the VCD waits a time at least equal to the sum of  $t_{3min}$  + the LRIS64K nominal response time (which depends on the LRIS64K data rate and subcarrier modulation mode) before sending a new EOF.

**Table 26. Timing values<sup>(1)</sup>**

	Minimum (min) values	Nominal (nom) values	Maximum (max) values
$t_1$	318.6 $\mu$ s	320.9 $\mu$ s	323.3 $\mu$ s
$t_2$	309.2 $\mu$ s	No $t_{nom}$	No $t_{max}$
$t_3$	$t_{1max}^{(2)} + t_{SOF}^{(3)}$	No $t_{nom}$	No $t_{max}$

1. The tolerance of specific timings is  $\pm 32/f_C$ .

2.  $t_{1max}$  does not apply for write alike requests. Timing conditions for write alike requests are defined in the command description.

3.  $t_{SOF}$  is the time taken by the LRIS64K to transmit an SOF to the VCD.  $t_{SOF}$  depends on the current data rate: High data rate or Low data rate.

## 24 Commands codes

The LRIS64K supports the commands described in this section. Their codes are given in [Table 27](#).

**Table 27. Command codes**

Command code standard	Function	Command code custom	Function
01h	Inventory	2Ch	Get Multiple Block Security Status
02h	Stay Quiet	B1h	Write-sector Password
20h	Read Single Block	B2h	Lock-sector Password
21h	Write Single Block	B3h	Present-sector Password
23h	Read Multiple Block	C0h	Fast Read Single Block
25h	Select	C1h	Fast Inventory Initiated
26h	Reset to Ready	C2h	Fast Initiate
27h	Write AFI	C3h	Fast Read Multiple Block
28h	Lock AFI	D1h	Inventory Initiated
29h	Write DSFID	D2h	Initiate
2Ah	Lock DSFID		
2Bh	Get System Info		

## 24.1 Inventory

When receiving the Inventory request, the LRIS64K runs the anticollision sequence. The Inventory\_flag is set to 1. The meaning of flags 5 to 8 is shown in [Table 20: Request flags 5 to 8 when Bit 3 = 1](#).

The request contains:

- the flags,
- the Inventory command code (see [Table 27: Command codes](#))
- the AFI if the AFI flag is set
- the mask length
- the mask value
- the CRC

The LRIS64K does not generate any answer in case of error.

**Table 28. Inventory request format**

Request SOF	Request_flags	Inventory	Optional AFI <sup>(1)</sup>	Mask length	Mask value	CRC16	Request EOF
	8 bits	01h	8 bits	8 bits	0 - 64 bits	16 bits	

1. Gray means that the field is optional.

The response contains:

- the flags
- the Unique ID

**Table 29. Inventory response format**

Response SOF	Response_flags	DSFID	UID	CRC16	Response EOF
	8 bits	8 bits	64 bits	16 bits	

During an Inventory process, if the VCD does not receive an RF LRIS64K response, it waits a time  $t_3$  before sending an EOF to switch to the next slot.  $t_3$  starts from the rising edge of the request EOF sent by the VCD.

- If the VCD sends a 100% modulated EOF, the minimum value of  $t_3$  is:  
 $t_{3min} = 4384/f_C (323.3\mu s) + t_{SOF}$
- If the VCD sends a 10% modulated EOF, the minimum value of  $t_3$  is:  
 $t_{3min} = 4384/f_C (323.3\mu s) + t_{NRT}$

where:

- $t_{SOF}$  is the time required by the LRIS64K to transmit an SOF to the VCD
- $t_{NRT}$  is the nominal response time of the LRIS64K

$t_{NRT}$  and  $t_{SOF}$  are dependent on the LRIS64K-to-VCD data rate and subcarrier modulation mode.

## 24.2 Stay Quiet

Command code = 0x02

On receiving the Stay Quiet command, the LRIS64K enters the Quiet State if no error occurs, and does NOT send back a response. There is NO response to the Stay Quiet command even if an error occurs.

When in the Quiet state:

- the LRIS64K does not process any request if the Inventory\_flag is set,
- the LRIS64K processes any Addressed request

The LRIS64K exits the Quiet State when:

- it is reset (power off),
- receiving a Select request. It then goes to the Selected state,
- receiving a Reset to Ready request. It then goes to the Ready state.

**Table 30. Stay Quiet request format**

Request SOF	Request flags	Stay Quiet	UID	CRC16	Request EOF
	8 bits	02h	64 bits	16 bits	

The Stay Quiet command must always be executed in Addressed mode (Select\_flag is reset to 0 and Address\_flag is set to 1).

**Figure 41. Stay Quiet frame exchange between VCD and LRIS64K**

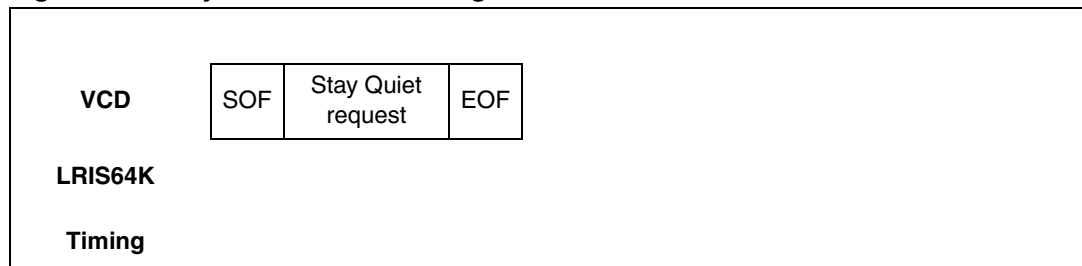

## 24.3 Read Single Block

On receiving the Read Single Block command, the LRIS64K reads the requested block and sends back its 32-bit value in the response. The Protocol\_extention\_flag should be set to 1 for the LRIS64K to operate correctly. If the Protocol\_extention\_flag is at 0, the LRIS64K answers with an error code. The Option\_flag is supported.

**Table 31. Read Single Block request format**

Request SOF	Request flags	Read Single Block	UID <sup>(1)</sup>	Block number	CRC16	Request EOF
	8 bits	20h	64 bits	16 bits	16 bits	

1. Gray means that the field is optional.

Request parameters:

- Option\_flag
- UID (optional)
- Block number

**Table 32. Read Single Block response format when Error\_flag is NOT set**

Response SOF	Response flags	Sector security status <sup>(1)</sup>	Data	CRC16	Response EOF
	8 bits	8 bits	32 bits	16 bits	

1. Gray means that the field is optional.

Response parameters:

- Sector security status if Option\_flag is set (see [Table 33: Sector security status](#))
- 4 bytes of block data

**Table 33. Sector security status**

b <sub>7</sub>	b <sub>6</sub>	b <sub>5</sub>	b <sub>4</sub>	b <sub>3</sub>	b <sub>2</sub>	b <sub>1</sub>	b <sub>0</sub>
Reserved for future use. All at 0			password control bits		Read / Write protection bits		0: Current sector not locked 1: Current sector locked

**Table 34. Read Single Block response format when Error\_flag is set**

Response SOF	Response flags	Error code	CRC16	Response EOF
	8 bits	8 bits	16 bits	

Response parameter:

- Error code as Error\_flag is set
  - 03h: the option is not supported
  - 0Fh: error with no information given
  - 10h: the specified block is not available
  - 15h: the specified block is read-protected

**Figure 42. Read Single Block frame exchange between VCD and LRIS64K**

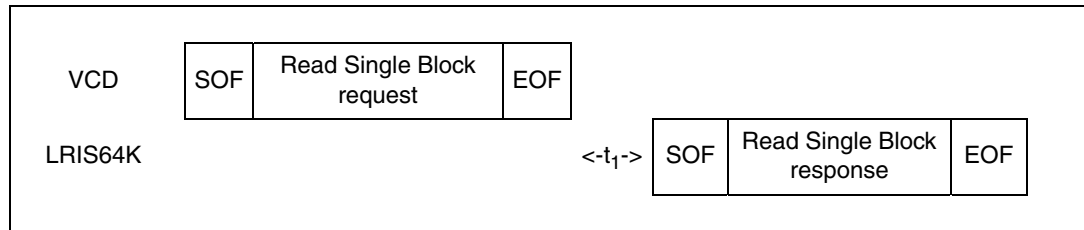

## 24.4 Write Single Block

On receiving the Write Single Block command, the LRIS64K writes the data contained in the request to the requested block and reports whether the write operation was successful in the response. The Protocol\_extention\_flag should be set to 1 for the LRIS64K to operate correctly. If the Protocol\_extention\_flag is at 0, the LRIS64K answers with an error code. The Option\_flag is supported.

During write cycle  $W_t$ , there should be no modulation (neither 100% nor 10%). Otherwise, the LRIS64K may not program correctly the data into the memory. The  $W_t$  time is equal to  $t_{1nom} + 18 \times 302 \mu s$ .

**Table 35. Write Single Block request format**

Request SOF	Request flags	Write Single Block	UID <sup>(1)</sup>	Block number	Data	CRC16	Request EOF
	8 bits	21h	64 bits	16 bits	32 bits	16 bits	

1. Gray means that the field is optional.

Request parameters:

- UID (optional)
- Block number
- Data

**Table 36. Write Single Block response format when Error\_flag is NOT set**

Response SOF	Response flags	CRC16	Response EOF
	8 bits	16 bits	

Response parameter:

- No parameter. The response is send back after the writing cycle.

**Table 37. Write Single Block response format when Error\_flag is set**

Response SOF	Response flags	Error code	CRC16	Response EOF
	8 bits	8 bits	16 bits	

Response parameter:

- Error code as Error\_flag is set:
  - 03h: the option is not supported
  - 0Fh: error with no information given
  - 10h: the specified block is not available
  - 12h: the specified block is locked and its contents cannot be changed.
  - 13h: the specified block was not successfully programmed

Figure 43. Write Single Block frame exchange between VCD and LRIS64K

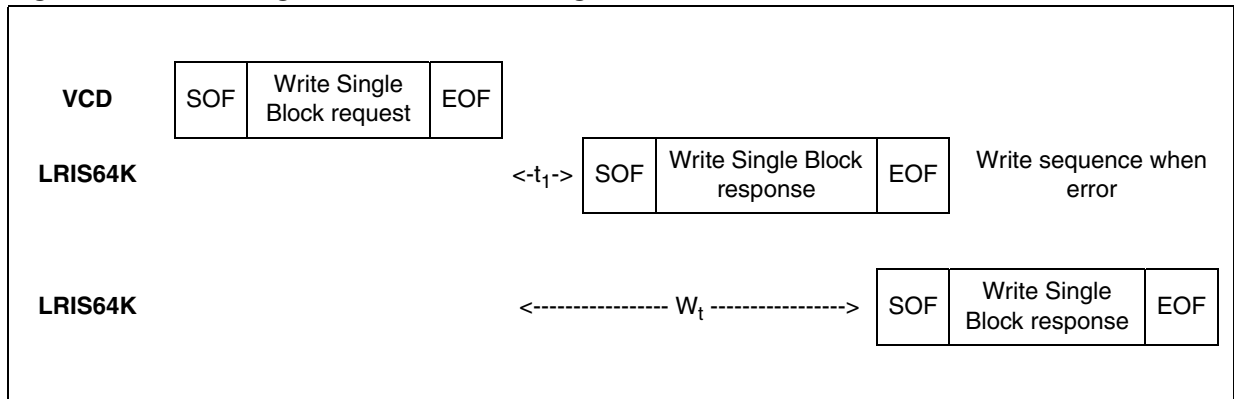

## 24.5 Read Multiple Block

When receiving the Read Multiple Block command, the LRIS64K reads the selected blocks and sends back their value in multiples of 32 bits in the response. The blocks are numbered from '00h to '7FFh' in the request and the value is minus one (-1) in the field. For example, if the “number of blocks” field contains the value 06h, 7 blocks are read. The maximum number of blocks is fixed at 32 assuming that they are all located in the same sector. If the number of blocks overlaps sectors, the LRIS64K returns an error code. The Protocol\_extention\_flag should be set to 1 for the LRIS64K to operate correctly. If the Protocol\_extention\_flag is at 0, the LRIS64K answers with an error code. The Option\_flag is supported.

**Table 38. Read Multiple Block request format**

Request SOF	Request flags	Read Multiple Block	UID <sup>(1)</sup>	First block number	Number of blocks	CRC16	Request EOF
	8 bits	23h	64 bits	16 bits	8 bits	16 bits	

1. Gray means that the field is optional.

Request parameters:

- Option\_flag
- UID (optional)
- First block number
- Number of blocks

**Table 39. Read Multiple Block response format when Error\_flag is NOT set**

Response SOF	Response flags	Sector security status <sup>(1)</sup>	Data	CRC16	Response EOF
	8 bits	8 bits <sup>(2)</sup>	32 bits <sup>(2)</sup>	16 bits	

1. Gray means that the field is optional.

2. Repeated as needed.

Response parameters:

- Sector security status if Option\_flag is set (see [Table 40: Sector security status](#))
- N blocks of data

**Table 40. Sector security status**

b <sub>7</sub>	b <sub>6</sub>	b <sub>5</sub>	b <sub>4</sub>	b <sub>3</sub>	b <sub>2</sub>	b <sub>1</sub>	b <sub>0</sub>
Reserved for future use. All at 0			password control bits		Read / Write protection bits		0: Current sector not locked 1: Current sector locked

**Table 41. Read Multiple Block response format when Error\_flag is set**

Response SOF	Response_flags	Error code	CRC16	Response EOF
	8 bits	8 bits	16 bits	

Response parameter:

- Error code as Error\_flag is set:
  - 03h: the option is not supported
  - 0Fh: error with no information given
  - 10h: the specified block is not available
  - 15h: the specified block is read-protected

**Figure 44. Read Multiple Block frame exchange between VCD and LRIS64K**

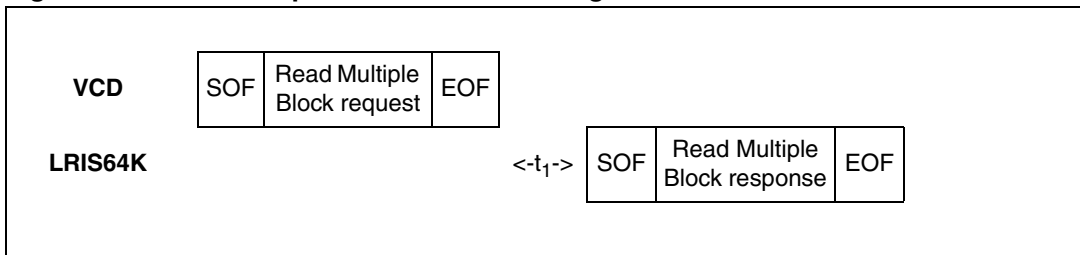

## 24.6 Select

When receiving the Select command:

- if the UID is equal to its own UID, the LRIS64K enters or stays in the Selected state and sends a response.
- if the UID does not match its own, the selected LRIS64K returns to the Ready state and does not send a response.

The LRIS64K answers an error code only if the UID is equal to its own UID. If not, no response is generated. If an error occurs, the LRIS64K remains in its current state.

**Table 42. Select request format**

Request SOF	Request flags	Select	UID	CRC16	Request EOF
	8 bits	25h	64 bits	16 bits	

Request parameter:

- UID

**Table 43. Select Block response format when Error\_flag is NOT set**

Response SOF	Response flags	CRC16	Response EOF
	8 bits	16 bits	

Response parameter:

- No parameter.

**Table 44. Select response format when Error\_flag is set**

Response SOF	Response flags	Error code	CRC16	Response EOF
	8 bits	8 bits	16 bits	

Response parameter:

- Error code as Error\_flag is set:
  - 03h: the option is not supported
  - 0Fh: error with no information given

**Figure 45. Select frame exchange between VCD and LRIS64K**

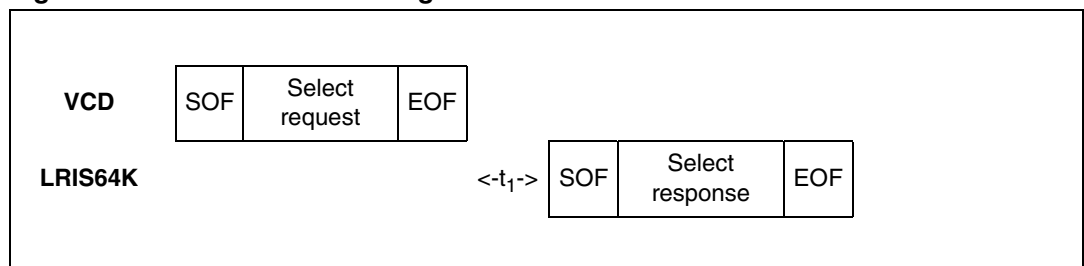

## 24.7 Reset to Ready

On receiving a Reset to Ready command, the LRIS64K returns to the Ready state if no error occurs. In the Addressed mode, the LRIS64K answers an error code only if the UID is equal to its own UID. If not, no response is generated.

**Table 45. Reset to Ready request format**

Request SOF	Request flags	Reset to Ready	UID <sup>(1)</sup>	CRC16	Request EOF
	8 bits	26h	64 bits	16 bits	

1. Gray means that the field is optional.

Request parameter:

- UID (optional)

**Table 46. Reset to Ready response format when Error\_flag is NOT set**

Response SOF	Response flags	CRC16	Response EOF
	8 bits	16 bits	

Response parameter:

- No parameter

**Table 47. Reset to ready response format when Error\_flag is set**

Response SOF	Response flags	Error code	CRC16	Response EOF
	8 bits	8 bits	16 bits	

Response parameter:

- Error code as Error\_flag is set:
  - 03h: the option is not supported
  - 0Fh: error with no information given

**Figure 46. Reset to Ready frame exchange between VCD and LRIS64K**

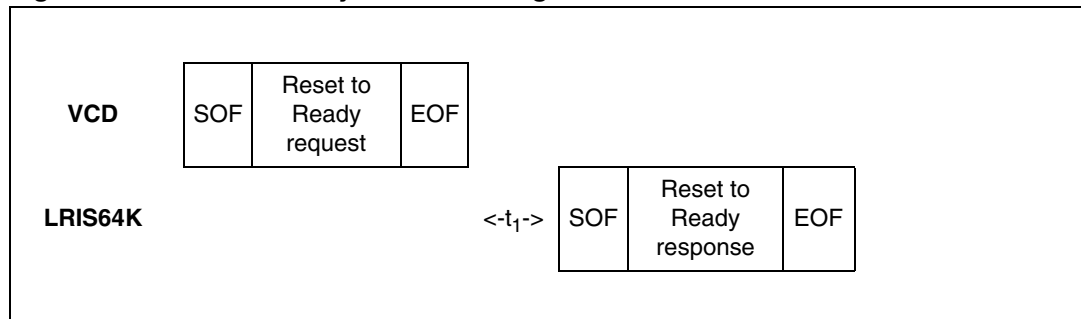

## 24.8 Write AFI

On receiving the Write AFI request, the LRIS64K programs the 8-bit AFI value to its memory. The Option\_flag is supported.

During write cycle  $W_t$ , there should be no modulation (neither 100% nor 10%). Otherwise, the LRIS64K may not write correctly the AFI value into the memory. The  $W_t$  time is equal to  $t_{1nom} + 18 \times 302 \mu s$ .

**Table 48. Write AFI request format**

Request SOF	Request _flags	Write AFI	UID <sup>(1)</sup>	AFI	CRC16	Request EOF
	8 bits	27h	64 bits	8 bits	16 bits	

1. Gray means that the field is optional.

Request parameter:

- UID (optional)
- AFI

**Table 49. Write AFI response format when Error\_flag is NOT set**

Response SOF	Response_flags	CRC16	Response EOF
	8 bits	16 bits	

Response parameter:

- No parameter.

**Table 50. Write AFI response format when Error\_flag is set**

Response SOF	Response_flags	Error code	CRC16	Response EOF
	8 bits	8 bits	16 bits	

Response parameter:

- Error code as Error\_flag is set
  - 03h: the option is not supported
  - 0Fh: error with no information given
  - 12h: the specified block is locked and its contents cannot be changed.
  - 13h: the specified block was not successfully programmed

Figure 47. Write AFI frame exchange between VCD and LRIS64K

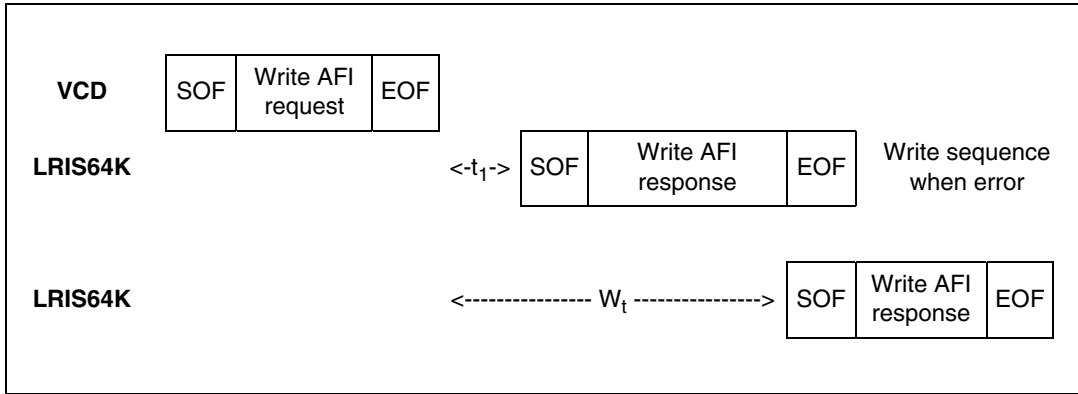

## 24.9 Lock AFI

On receiving the Lock AFI request, the LRIS64K locks the AFI value permanently. The Option\_flag is supported.

During write cycle  $W_t$ , there should be no modulation (neither 100% nor 10%). Otherwise, the LRIS64K may not Lock correctly the AFI value in memory. The  $W_t$  time is equal to  $t_{1nom} + 18 \times 302 \mu s$ .

**Table 51. Lock AFI request format**

Request SOF	Request flags	Lock AFI	UID <sup>(1)</sup>	CRC16	Request EOF
	8 bits	28h	64 bits	16 bits	

1. Gray means that the field is optional.

Request parameter:

- UID (optional)

**Table 52. Lock AFI response format when Error\_flag is NOT set**

Response SOF	Response flags	CRC16	Response EOF
	8 bits	16 bits	

Response parameter:

- No parameter

**Table 53. Lock AFI response format when Error\_flag is set**

Response SOF	Response flags	Error code	CRC16	Response EOF
	8 bits	8 bits	16 bits	

Response parameter:

- Error code as Error\_flag is set
  - 03h: the option is not supported
  - 0Fh: error with no information given
  - 11h: the specified block is already locked and thus cannot be locked again
  - 14h: the specified block was not successfully locked

Figure 48. Lock AFI frame exchange between VCD and LRIS64K

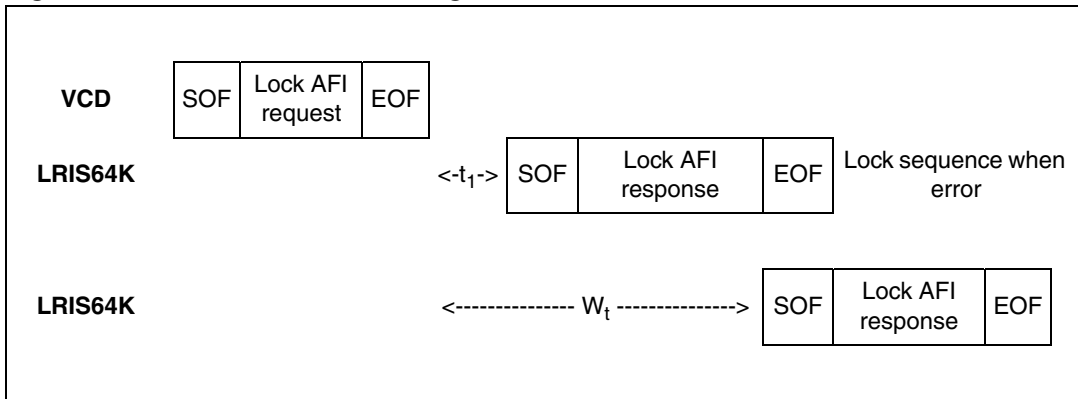

## 24.10 Write DSFID

On receiving the Write DSFID request, the LRIS64K programs the 8-bit DSFID value to its memory. The Option\_flag is supported.

During write cycle  $W_t$ , there should be no modulation (neither 100% nor 10%). Otherwise, the LRIS64K may not write correctly the DSFID value in memory. The  $W_t$  time is equal to  $t_{1nom} + 18 \times 302 \mu s$ .

**Table 54. Write DSFID request format**

Request SOF	Request_flags	Write DSFID	UID <sup>(1)</sup>	DSFID	CRC16	Request EOF
	8 bits	29h	64 bits	8 bits	16 bits	

1. Gray means that the field is optional.

Request parameter:

- UID (optional)
- DSFID

**Table 55. Write DSFID response format when Error\_flag is NOT set**

Response SOF	Response_flags	CRC16	Response EOF
	8 bits	16 bits	

Response parameter:

- No parameter

**Table 56. Write DSFID response format when Error\_flag is set**

Response SOF	Response_flags	Error code	CRC16	Response EOF
	8 bits	8 bits	16 bits	

Response parameter:

- Error code as Error\_flag is set
  - 03h: the option is not supported
  - 0Fh: error with no information given
  - 12h: the specified block is locked and its contents cannot be changed.
  - 13h: the specified block was not successfully programmed

Figure 49. Write DSFID frame exchange between VCD and LRIS64K

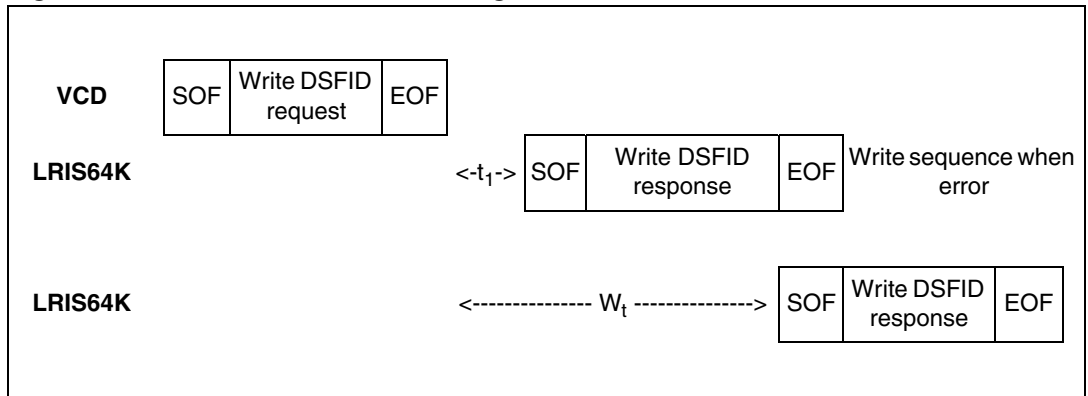

## 24.11 Lock DSFID

On receiving the Lock DSFID request, the LRIS64K locks the DSFID value permanently. The Option\_flag is supported.

During write cycle  $W_t$ , there should be no modulation (neither 100% nor 10%). Otherwise, the LRIS64K may not lock correctly the DSFID value in memory. The  $W_t$  time is equal to  $t_{1nom} + 18 \times 302 \mu s$ .

**Table 57. Lock DSFID request format**

Request SOF	Request_flags	Lock DSFID	UID <sup>(1)</sup>	CRC16	Request EOF
	8 bits	2Ah	64 bits	16 bits	

1. Gray means that the field is optional.

Request parameter:

- UID (optional)

**Table 58. Lock DSFID response format when Error\_flag is NOT set**

Response SOF	Response_flags	CRC16	Response EOF
	8 bits	16 bits	

Response parameter:

- No parameter.

**Table 59. Lock DSFID response format when Error\_flag is set**

Response SOF	Response_flags	Error code	CRC16	Response EOF
	8 bits	8 bits	16 bits	

Response parameter:

- Error code as Error\_flag is set:
  - 03h: the option is not supported
  - 0Fh: error with no information given
  - 11h: the specified block is already locked and thus cannot be locked again
  - 14h: the specified block was not successfully locked

Figure 50. Lock DSFID frame exchange between VCD and LRIS64K

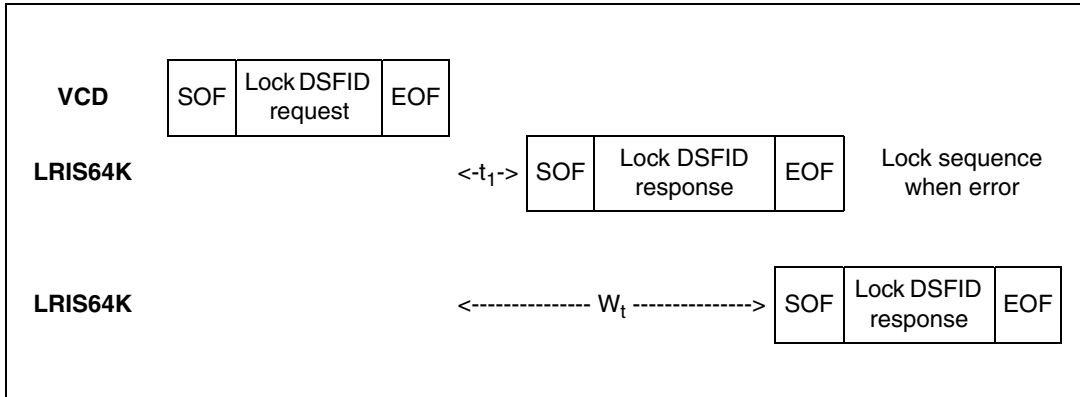

## 24.12 Get System Info

When receiving the Get System Info command, the LRIS64K sends back its information data in the response. The Option\_flag is supported and must be reset to 0. The Get System Info can be issued in both Addressed and Non Addressed modes.

The Protocol\_extention\_flag should be set to 1 for the LRIS64K to operate correctly. If the Protocol\_extention\_flag is at 0, the LRIS64K answers with an error code.

**Table 60. Get System Info request format**

Request SOF	Request _flags	Get System Info	UID <sup>(1)</sup>	CRC16	Request EOF
	8 bits	2Bh	64 bits	16 bits	

1. Gray means that the field is optional.

Request parameter:

- UID (optional)

**Table 61. Get System Info response format when Error\_flag is NOT set**

Response SOF	Response _flags	Information flags	UID	DSFID	AFI	Memory size	IC reference	CRC16	Response EOF
	00h	0Fh	64 bits	8 bits	8 bits	0307FFh	44h	16 bits	

Response parameters:

- Information flags set to 0Fh. DSFID, AFI, Memory Size and IC reference fields are present
- UID code on 64 bits
- DSFID value
- AFI value
- Memory size. The LRIS64K provides 2048 blocks (07FFh) of 4 byte (03h)
- IC reference. Only the 6 MSB are significant.

**Table 62. Get System Info response format when Error\_flag is set**

Response SOF	Response_flags	Error code	CRC16	Response EOF
	01h	8 bits	16 bits	

Response parameter:

- Error code as Error\_flag is set:
  - 03h: Option not supported
  - 0Fh: other error

Figure 51. Get System Info frame exchange between VCD and LRIS64K

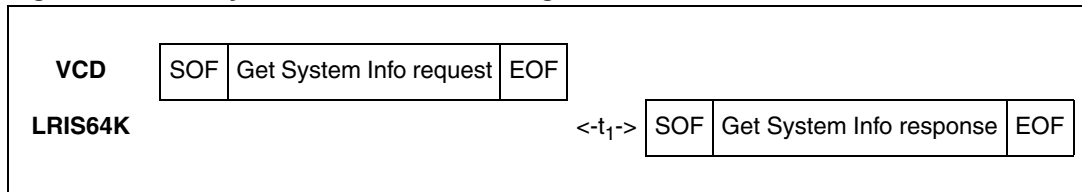

## 24.13 Get Multiple Block Security Status

When receiving the Get Multiple Block Security Status command, the LRIS64K sends back the sector security status. The blocks are numbered from '00h to '07FFh' in the request and the value is minus one (-1) in the field. For example, a value of '06' in the "Number of blocks" field requests to return the security status of 7 blocks.

The Protocol\_extention\_flag should be set to 1 for the LRIS64K to operate correctly. If the Protocol\_extention\_flag is at 0, the LRIS64K answers with an error code.

During the LRIS64K response, if the internal block address counter reaches 07FFh, it rolls over to 0000h and the Sector Security Status bytes for that location are sent back to the reader.

**Table 63. Get Multiple Block Security Status request format**

Request SOF	Request _flags	Get Multiple Block Security Status	UID <sup>(1)</sup>	First block number	Number of blocks	CRC16	Request EOF
	8 bits	2Ch	64 bits	16 bits	16 bits	16 bits	

1. Gray means that the field is optional.

Request parameter:

- UID (optional)
- First block number
- Number of blocks

**Table 64. Get Multiple Block Security Status response format when Error\_flag is NOT set**

Response SOF	Response _flags	Sector security status	CRC16	Response EOF
	8 bits	8 bits <sup>(1)</sup>	16 bits	

1. Repeated as needed.

Response parameters:

- Sector security status (see [Table 65: Sector security status](#))

**Table 65. Sector security status**

b <sub>7</sub>	b <sub>6</sub>	b <sub>5</sub>	b <sub>4</sub>	b <sub>3</sub>	b <sub>2</sub>	b <sub>1</sub>	b <sub>0</sub>
Reserved for future use. All at 0			password control bits		Read / Write protection bits		0: Current sector not locked 1: Current sector locked

**Table 66. Get Multiple Block Security Status response format when Error\_flag is set**

Response SOF	Response_flags	Error code	CRC16	Response EOF
	8 bits	8 bits	16 bits	

Response parameter:

- Error code as Error\_flag is set:
  - 03h: the option is not supported
  - 0Fh: error with no information given
  - 10h: the specified block is not available

**Figure 52. Get Multiple Block Security Status frame exchange between VCD and LRIS64K**

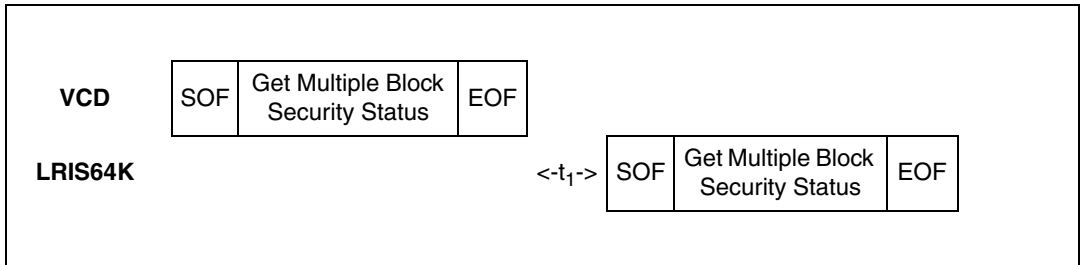

## 24.14 Write-sector Password

On receiving the Write-sector Password command, the LRIS64K uses the data contained in the request to write the password and reports whether the operation was successful in the response. The Option\_flag is supported.

During write cycle time  $W_t$ , there must be no modulation at all (neither 100% nor 10%). Otherwise, the LRIS64K may not correctly program the data into the memory. The  $W_t$  time is equal to  $t_{1nom} + 18 \times 302 \mu s$ . After a successful write, the new value of the selected password is automatically activated. It is not required to present the new password value until LRIS64K power-down.

**Table 67. Write-sector Password request format**

Request SOF	Request_flags	Write-sector Password	IC Mfg code	UID <sup>(1)</sup>	Password number	Data	CRC16	Request EOF
	8 bits	B1h	02h	64 bits	8 bits	32 bits	16 bits	

1. Gray means that the field is optional.

Request parameter:

- UID (optional)
- Password number (01h = Pswd1, 02h = Pswd2, 03h = Pswd3, other = Error)
- Data

**Table 68. Write-sector Password response format when Error\_flag is NOT set**

Response SOF	Response_flags	CRC16	Response EOF
	8 bits	16 bits	

Response parameter:

- 32-bit password value. The response is sent back after the write cycle.

**Table 69. Write-sector Password response format when Error\_flag is set**

Response SOF	Response_flags	Error code	CRC16	Response EOF
	8 bits	8 bits	16 bits	

Response parameter:

- Error code as Error\_flag is set:
  - 02h: the command is not recognized, for example: a format error occurred
  - 03h: the option is not supported
  - 0Fh: error with no information given
  - 10h: the specified block is not available
  - 12h: the specified block is locked and its contents cannot be changed.
  - 13h: the specified block was not successfully programmed

Figure 53. Write-sector Password frame exchange between VCD and LRIS64K

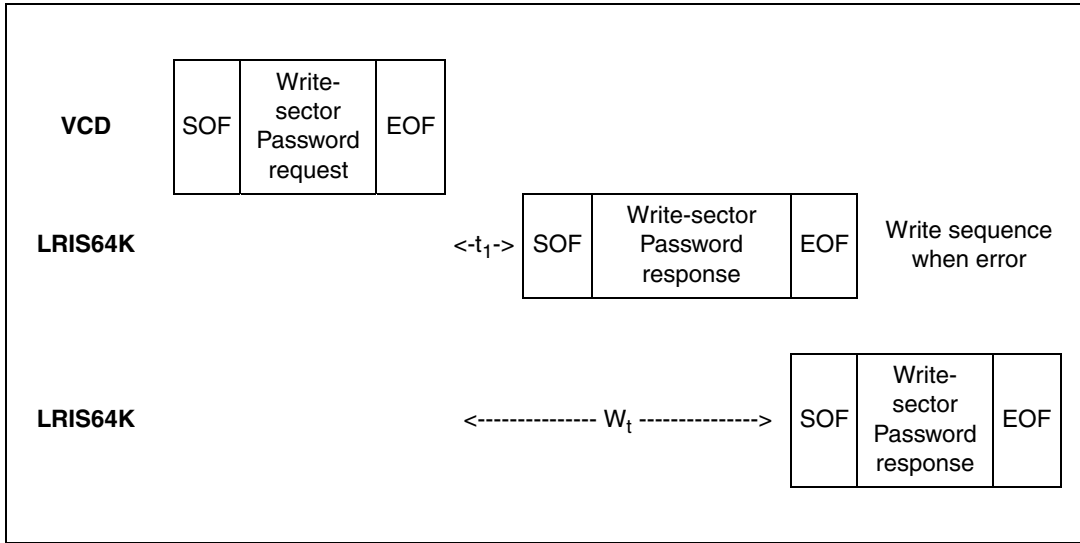

## 24.15 Lock-sector Password

On receiving the Lock-sector Password command, the LRIS64K sets the access rights and permanently locks the selected sector. The Option\_flag is supported.

A sector is selected by giving the address of one of its blocks in the Lock-sector Password request (Sector number field). For example, addresses 0 to 31 are used to select sector 0 and addresses 32 to 63 are used to select sector 1. Care must be taken when issuing the Lock-sector Password command as all the blocks belonging to the same sector are automatically locked by a single command.

The Protocol\_extention\_flag should be set to 1 for the LRIS64K to operate correctly. If the Protocol\_extention\_flag is at 0, the LRIS64K answers with an error code.

During write cycle  $W_t$ , there should be no modulation (neither 100% nor 10%) otherwise, the LRIS64K may not correctly lock the memory block.

The  $W_t$  time is equal to  $t_{1nom} + 18 \times 302 \mu s$ .

**Table 70. Lock-sector Password request format**

Request SOF	Request_flags	Lock-sector Password	IC Mfg code	UID <sup>(1)</sup>	Sector number	Sector security status	CRC16	Request EOF
	8 bits	B2h	02h	64 bits	16 bits	8 bits	16 bits	

1. Gray means that the field is optional.

Request parameters:

- (optional) UID
- Sector number
- Sector security status (refer to [Table 71](#))

**Table 71. Sector security status**

b <sub>7</sub>	b <sub>6</sub>	b <sub>5</sub>	b <sub>4</sub>	b <sub>3</sub>	b <sub>2</sub>	b <sub>1</sub>	b <sub>0</sub>
0	0	0	password control bits		Read / Write protection bits		1

**Table 72. Lock-sector Password response format when Error\_flag is NOT set**

Response SOF	Response_flags	CRC16	Response EOF
	8 bits	16 bits	

Response parameter:

- No parameter.

**Table 73. Lock-sector Password response format when Error\_flag is set**

Response SOF	Response_flags	Error code	CRC16	Response EOF
	8 bits	8 bits	16 bits	

Response parameter:

- Error code as Error\_flag is set:
  - 02h: the command is not recognized, for example: a format error occurred
  - 03h: the option is not supported
  - 0Fh: error with no information given
  - 10h: the specified block is not available
  - 11h: the specified block is already locked and thus cannot be locked again
  - 14h: the specified block was not successfully locked

**Figure 54. Lock-sector Password frame exchange between VCD and LRIS64K**

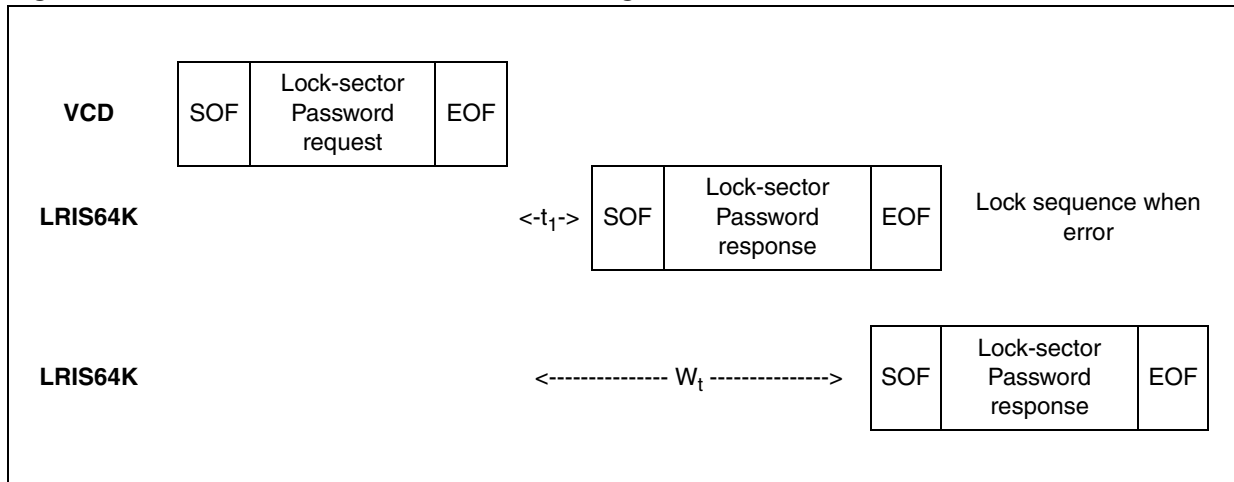

## 24.16 Present-sector Password

On receiving the Present-sector Password command, the LRIS64K compares the requested password with the data contained in the request and reports whether the operation has been successful in the response. The Option\_flag is supported.

During the  $W_t$  comparison cycle time, there should be no modulation (neither 100% nor 10%) otherwise, the LRIS64K Password value may not be correctly compared.

The  $W_t$  time is equal to  $t_{1nom} + 18 \times 302 \mu s$ .

After a successful command, the access to all the memory blocks linked to the password is changed as described in [Section 3.1: LRIS64K RF block security](#).

**Table 74. Present-sector Password request format**

Request SOF	Request_flags	Present-sector Password	IC Mfg code	UID <sup>(1)</sup>	Password number	Data	CRC16	Request EOF
	8 bits	B3h	02h	64 bits	8 bits	32 bits	16 bits	

1. Gray means that the field is optional.

Request parameter:

- UID (optional)
- Password Number (0x01 = Pswd1, 0x02 = Pswd2, 0x03 = Pswd3, other = Error)
- Data

**Table 75. Present-sector Password response format when Error\_flag is NOT set**

Response SOF	Response_flags	CRC16	Response EOF
	8 bits	16 bits	

Response parameter:

- No parameter. The response is send back after the writing cycle

**Table 76. Present-sector Password response format when Error\_flag is set**

Response SOF	Response_flags	Error code	CRC16	Response EOF
	8 bits	8 bits	16 bits	

Response parameter:

- Error code as Error\_flag is set:
  - 02h: the command is not recognized, for example: a format error occurred
  - 03h: the option is not supported
  - 0Fh: error with no information given
  - 10h: the specified block is not available

Figure 55. Present-sector Password frame exchange between VCD and LRIS64K

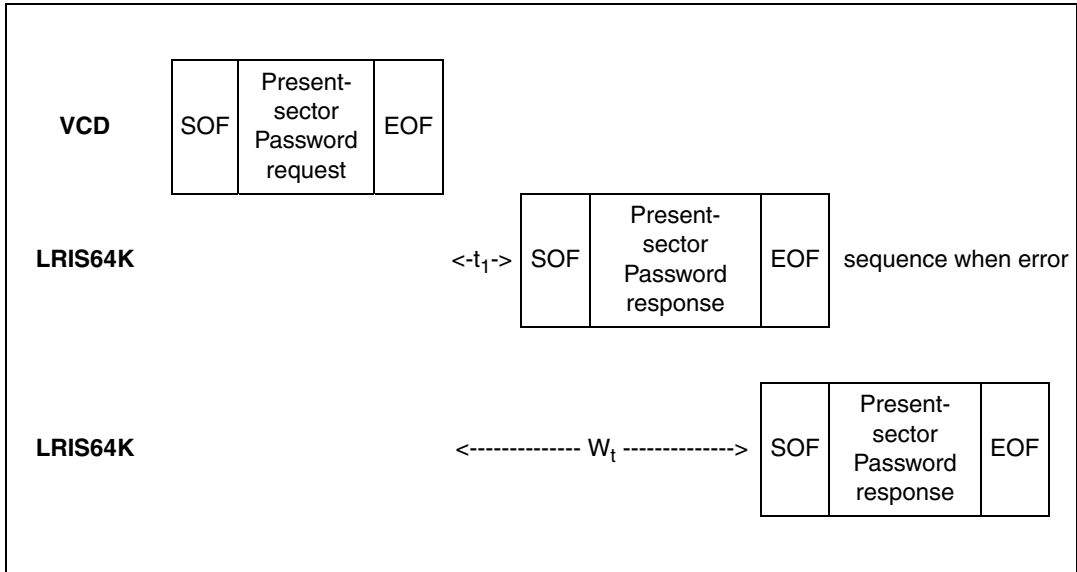

## 24.17 Fast Read Single Block

On receiving the Fast Read Single Block command, the LRIS64K reads the requested block and sends back its 32-bit value in the response. The Option\_flag is supported. The data rate of the response is multiplied by 2.

The Protocol\_extention\_flag should be set to 1 for the LRIS64K to operate correctly. If the Protocol\_extention\_flag is at 0, the LRIS64K answers with an error code.

**Table 77. Fast Read Single Block request format**

Request SOF	Request flags	Fast Read Single Block	IC Mfg code	UID <sup>(1)</sup>	Block number	CRC16	Request EOF
	8 bits	C0h	02h	64 bits	16 bits	16 bits	

1. Gray means that the field is optional.

Request parameters:

- Option\_flag
- UID (optional)
- Block number

**Table 78. Fast Read Single Block response format when Error\_flag is NOT set**

Response SOF	Response flags	Sector security status <sup>(1)</sup>	Data	CRC16	Response EOF
	8 bits	8 bits	32 bits	16 bits	

1. Gray means that the field is optional.

Response parameters:

- Sector security status if Option\_flag is set (see [Table 79](#))
- 4 bytes of block data

**Table 79. Sector security status**

b <sub>7</sub>	b <sub>6</sub>	b <sub>5</sub>	b <sub>4</sub>	b <sub>3</sub>	b <sub>2</sub>	b <sub>1</sub>	b <sub>0</sub>
Reserved for future used. All at 0			password control bits		Read / Write protection bits		0: Current sector not locked 1: Current sector locked

**Table 80. Fast Read Single Block response format when Error\_flag is set**

Response SOF	Response flags	Error code	CRC16	Response EOF
	8 bits	8 bits	16 bits	

Response parameter:

- Error code as Error\_flag is set:
  - 02h: the command is not recognized, for example: a format error occurred
  - 03h: the option is not supported
  - 0Fh: error with no information given
  - 10h: the specified block is not available
  - 15h: the specified block is read protected

**Figure 56. Fast Read Single Block frame exchange between VCD and LRIS64K**

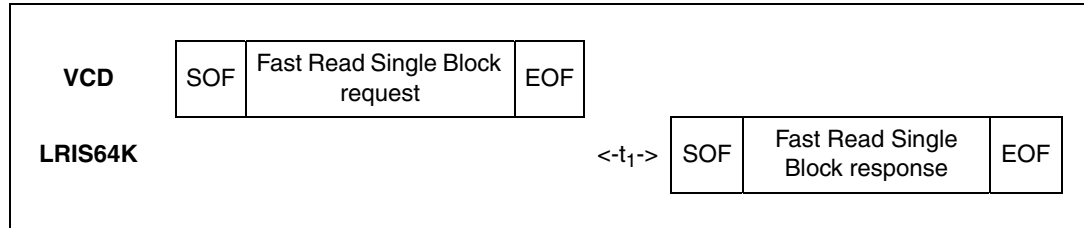

## 24.18 Fast Inventory Initiated

Before receiving the Fast Inventory Initiated command, the LRIS64K must have received an Initiate or a Fast Initiate command in order to set the Initiate\_ flag. If not, the LRIS64K does not answer to the Fast Inventory Initiated command.

On receiving the Fast Inventory Initiated request, the LRIS64K runs the anticollision sequence. The Inventory\_flag must be set to 1. The meaning of flags 5 to 8 is shown in [Table 20: Request flags 5 to 8 when Bit 3 = 1](#). The data rate of the response is multiplied by 2.

The request contains:

- the flags,
- the Inventory command code
- the AFI if the AFI flag is set
- the mask length
- the mask value
- the CRC

The LRIS64K does not generate any answer in case of error.

**Table 81. Fast Inventory Initiated request format**

Request SOF	Request _flags	Fast Inventory Initiated	IC Mfg code	Optional AFI <sup>(1)</sup>	Mask length	Mask value	CRC16	Request EOF
	8 bits	C1h	02h	8 bits	8 bits	0 - 64 bits	16 bits	

1. Gray means that the field is optional.

The Response contains:

- the flags
- the Unique ID

**Table 82. Fast Inventory Initiated response format**

Response SOF	Response _flags	DSFID	UID	CRC16	Response EOF
	8 bits	8 bits	64 bits	16 bits	

During an Inventory process, if the VCD does not receive an RF LRIS64K response, it waits a time  $t_3$  before sending an EOF to switch to the next slot.  $t_3$  starts from the rising edge of the request EOF sent by the VCD.

- If the VCD sends a 100% modulated EOF, the minimum value of  $t_3$  is:  
 $t_{3min} = 4384/f_C (323.3\mu s) + t_{SOF}$
- If the VCD sends a 10% modulated EOF, the minimum value of  $t_3$  is:  
 $t_{3min} = 4384/f_C (323.3\mu s) + t_{NRT}$

where:

- $t_{SOF}$  is the time required by the LRIS64K to transmit an SOF to the VCD
- $t_{NRT}$  is the nominal response time of the LRIS64K

$t_{NRT}$  and  $t_{SOF}$  are dependent on the LRIS64K-to-VCD data rate and subcarrier modulation mode.

## 24.19 Fast Initiate

On receiving the Fast Initiate command, the LRIS64K will set the internal Initiate\_flag and send back a response only if it is in the Ready state. The command has to be issued in the Non Addressed mode only (Select\_flag is reset to 0 and Address\_flag is reset to 0). If an error occurs, the LRIS64K does not generate any answer. The Initiate\_flag is reset after a power off of the LRIS64K. The data rate of the response is multiplied by 2.

The request contains:

- No data

**Table 83. Fast Initiate request format**

Request SOF	Request_flags	Fast Initiate	IC Mfg Code	CRC16	Request EOF
	8 bits	C2h	02h	16 bits	

The response contains:

- the flags
- the Unique ID

**Table 84. Fast Initiate response format**

Response SOF	Response_flags	DSFID	UID	CRC16	Response EOF
	8 bits	8 bits	64 bits	16 bits	

**Figure 57. Fast Initiate frame exchange between VCD and LRIS64K**

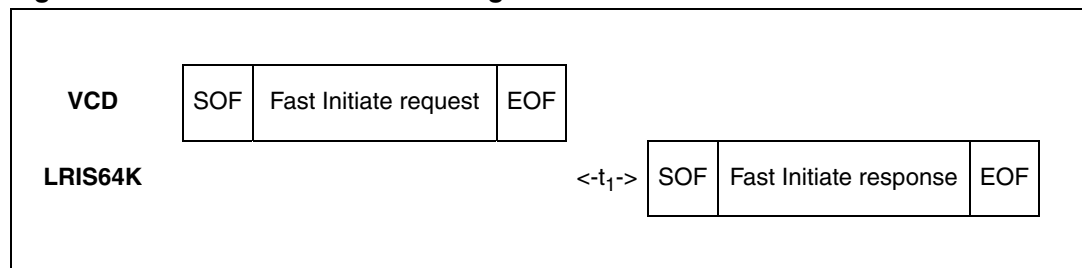

## 24.20 Fast Read Multiple Block

On receiving the Fast Read Multiple Block command, the LRIS64K reads the selected blocks and sends back their value in multiples of 32 bits in the response. The blocks are numbered from '00h to '7FFh' in the request and the value is minus one (–1) in the field. For example, if the “number of blocks” field contains the value 06h, 7 blocks are read. The maximum number of blocks is fixed to 32 assuming that they are all located in the same sector. If the number of blocks overlaps sectors, the LRIS64K returns an error code.

The Protocol\_extention\_flag should be set to 1 for the LRIS64K to operate correctly. If the Protocol\_extention\_flag is at 0, the LRIS64K answers with an error code.

The Option\_flag is supported. The data rate of the response is multiplied by 2.

**Table 85. Fast Read Multiple Block request format**

Request SOF	Request flags	Fast Read Multiple Block	ICMfg code	UID <sup>(1)</sup>	First block number	Number of blocks	CRC16	Request EOF
	8 bits	C3h	02h	64 bits	16 bits	8 bits	16 bits	

1. Gray means that the field is optional.

Request parameters:

- Option\_flag
- UID (Optional)
- First block number
- Number of blocks

**Table 86. Fast Read Multiple Block response format when Error\_flag is NOT set**

Response SOF	Response flags	Sector security status <sup>(1)</sup>	Data	CRC16	Response EOF
	8 bits	8 bits <sup>(2)</sup>	32 bits <sup>(2)</sup>	16 bits	

1. Gray means that the field is optional.

2. Repeated as needed.

Response parameters:

- Sector security status if Option\_flag is set (see [Table 87: Sector security status if Option\\_flag is set](#))
- N block of data

**Table 87. Sector security status if Option\_flag is set**

b <sub>7</sub>	b <sub>6</sub>	b <sub>5</sub>	b <sub>4</sub>	b <sub>3</sub>	b <sub>2</sub>	b <sub>1</sub>	b <sub>0</sub>
Reserved for future use. All at 0			password control bits		Read / Write protection bits		0: Current sector not locked 1: Current sector locked

**Table 88. Fast Read Multiple Block response format when Error\_flag is set**

Response SOF	Response_flags	Error code	CRC16	Response EOF
	8 bits	8 bits	16 bits	

Response parameter:

- Error code as Error\_flag is set:
  - 0Fh: other error
  - 10h: block address not available

**Figure 58. Fast Read Multiple Block frame exchange between VCD and LRIS64K**

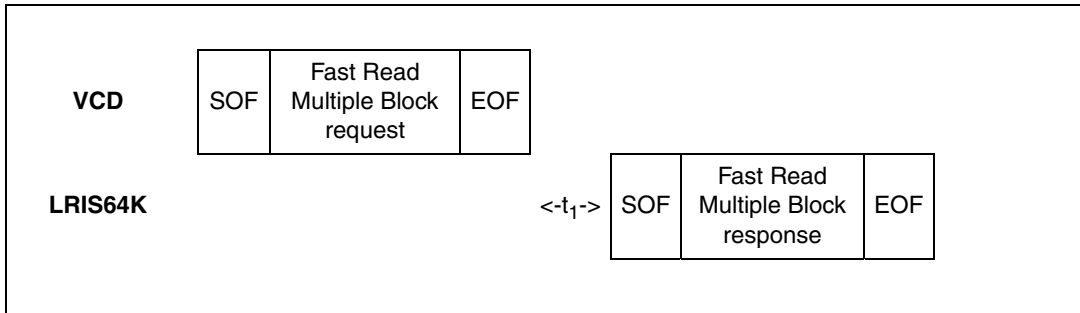

## 24.21 Inventory Initiated

Before receiving the Inventory Initiated command, the LRIS64K must have received an Initiate or a Fast Initiate command in order to set the Initiate\_ flag. If not, the LRIS64K does not answer to the Inventory Initiated command.

On receiving the Inventory Initiated request, the LRIS64K runs the anticollision sequence. The Inventory\_flag must be set to 1. The meaning of flags 5 to 8 is given in [Table 20: Request flags 5 to 8 when Bit 3 = 1](#).

The request contains:

- the flags,
- the Inventory Command code
- the AFI if the AFI flag is set
- the mask length
- the mask value
- the CRC

The LRIS64K does not generate any answer in case of error.

**Table 89. Inventory Initiated request format**

Request SOF	Request _flags	Inventory Initiated	IC Mfg code	Optional AFI	Mask length	Mask value	CRC16	Request EOF
	8 bits	D1h	02h	8 bits	8 bits	0 - 64 bits	16 bits	

The response contains:

- the flags
- the Unique ID

**Table 90. Inventory Initiated response format**

Response SOF	Response _flags	DSFID	UID	CRC16	Response EOF
	8 bits	8 bits	64 bits	16 bits	

During an Inventory process, if the VCD does not receive an RF LRIS64K response, it waits a time  $t_3$  before sending an EOF to switch to the next slot.  $t_3$  starts from the rising edge of the request EOF sent by the VCD.

- If the VCD sends a 100% modulated EOF, the minimum value of  $t_3$  is:  
 $t_{3min} = 4384/f_C (323.3\mu s) + t_{SOF}$
- If the VCD sends a 10% modulated EOF, the minimum value of  $t_3$  is:  
 $t_{3min} = 4384/f_C (323.3\mu s) + t_{NRT}$

where:

- $t_{SOF}$  is the time required by the LRIS64K to transmit an SOF to the VCD
- $t_{NRT}$  is the nominal response time of the LRIS64K

$t_{NRT}$  and  $t_{SOF}$  are dependent on the LRIS64K-to-VCD data rate and subcarrier modulation mode.

## 24.22 Initiate

On receiving the Initiate command, the LRIS64K will set the internal Initiate\_flag and send back a response only if it is in the ready state. The command has to be issued in the Non Addressed mode only (Select\_flag is reset to 0 and Address\_flag is reset to 0). If an error occurs, the LRIS64K does not generate any answer. The Initiate\_flag is reset after a power off of the LRIS64K.

The request contains:

- No data

**Table 91. Initiate request format**

Request SOF	Request_flags	Initiate	IC Mfg code	CRC16	Request EOF
	8 bits	D2h	02h	16 bits	

The response contains:

- the flags
- the Unique ID

**Table 92. Initiate Initiated response format**

Response SOF	Response_flags	DSFID	UID	CRC16	Response EOF
	8 bits	8 bits	64 bits	16 bits	

**Figure 59. Initiate frame exchange between VCD and LRIS64K**

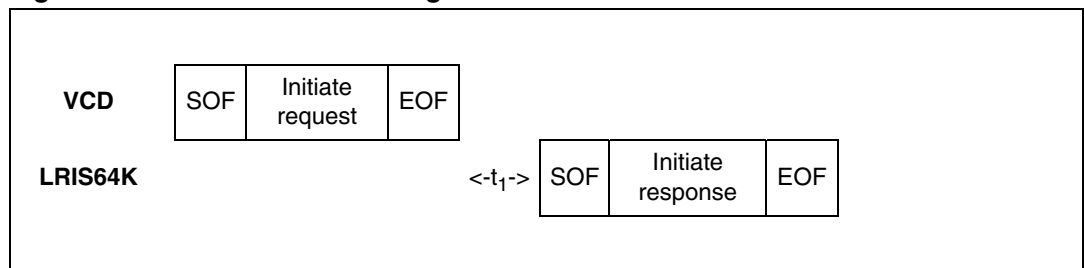

## 25 Maximum rating

Stressing the device above the rating listed in the absolute maximum ratings table may cause permanent damage to the device. These are stress ratings only and operation of the device at these or any other conditions above those indicated in the operating sections of this specification is not implied. Exposure to absolute maximum rating conditions for extended periods may affect device reliability. Refer also to the STMicroelectronics SURE Program and other relevant quality documents.

**Table 93. Absolute maximum ratings**

Symbol	Parameter		Min.	Max.	Unit
T <sub>STG</sub>	Storage conditions	Sawn Bumped Wafer (kept in its antistatic bag)	15	25	°C
t <sub>STG</sub>	Storage time			6	months
I <sub>CC</sub>	Supply current on AC0 / AC1		-20	20	mA
V <sub>MAX</sub>	Input voltage on AC0 / AC1		-7	7	V
V <sub>ESD</sub>	Electrostatic discharge voltage	AC0 - AC1 (HBM) <sup>(1)</sup>	-800	800	V
		AC0 - AC1 (MM)	-100	100	V

1. AEC-Q100-002 (compliant with JEDEC Std JESD22-A114A, C1 = 100 pF, R1 = 1500 Ω, R2 = 500 Ω).

## 26 RF DC and AC parameters

This section summarizes the operating and measurement conditions, and the DC and AC characteristics of the device in RF mode. The parameters in the DC and AC Characteristic tables that follow are derived from tests performed under the Measurement Conditions summarized in the relevant tables. Designers should check that the operating conditions in their circuit match the measurement conditions when relying on the quoted parameters.

**Table 94. RF AC characteristics<sup>(1) (2)</sup>**

Symbol	Parameter	Condition	Min	Typ	Max	Unit
$f_{CC}$	External RF signal frequency		13.553	13.56	13.567	MHz
H_ISO	Operating field according to ISO	$T_A = 0\text{ °C to }50\text{ °C}$	150		5000	mA/m
H_Extended	Operating field in extended temperature range	$T_A = -40\text{ °C to }85\text{ °C}$	150		3500	mA/m
MI <sub>CARRIER</sub>	10% carrier modulation index <sup>(3) (4)</sup> $MI=(A-B)/(A+B)$	$150\text{ mA/m} > H\_ISO > 1000\text{ mA/m}$	15		30	%
		$H\_ISO > 1000\text{ mA/m}$	10		30	
$t_{RFR}, t_{RFF}$	10% rise and fall time		0.5		3.0	$\mu\text{s}$
$t_{RFSBL}$	10% minimum pulse width for bit		7.1		9.44	$\mu\text{s}$
MI <sub>CARRIER</sub>	100% carrier modulation index	$MI=(A-B)/(A+B)$	95		100	%
$t_{RFR}, t_{RFF}$	100% rise and fall time		0.5		3.5	$\mu\text{s}$
$t_{RFSBL}$	100% minimum pulse width for bit		7.1		9.44	$\mu\text{s}$
$t_{JIT}$	Bit pulse jitter		-2		+2	$\mu\text{s}$
$t_{MIN\ CD}$	Minimum time from carrier generation to first data	From H-field min		0.1	1	ms
$f_{SH}$	Subcarrier frequency high	$f_{CC}/32$		423.75		kHz
$f_{SL}$	Subcarrier frequency low	$f_{CC}/28$		484.28		kHz
$t_1$	Time for LRIS64K response	$4224/f_S$	318.6	320.9	323.3	$\mu\text{s}$
$t_2$	Time between commands	$4224/f_S$	309	311.5	314	$\mu\text{s}$
$W_t$	RF write time (including internal Verify)			5.75		ms

1.  $T_A = -40$  to  $85\text{ °C}$ .

2. All timing measurements were performed between  $0\text{ °C}$  and  $50\text{ °C}$  on a reference antenna with the following characteristics:

External size: 75 mm x 48 mm  
 Number of turns: 5  
 Width of conductor: 0.5 mm  
 Space between 2 conductors: 0.3 mm  
 Value of the tuning capacitor in SO8: 27.5 pF (LRIS64K)  
 Value of the coil: 5  $\mu\text{H}$   
 Tuning frequency: 13.56 MHz.

3. Characterized only, not 100% tested

4. 15% (or more) carrier modulation index offers a better signal/noise ratio and therefore a wider operating range with a better noise immunity

**Table 95. RF DC characteristics<sup>(1)</sup>**

Symbol	Parameter	Test conditions	Min.	Typ.	Max.	Unit
V <sub>CC</sub>	Limited voltage				2.0	V
V <sub>BACK</sub>	Backscattered level as defined by ISO test	ISO/IEC 10373-7	10			mV
I <sub>CC</sub>	Supply current	Read	V <sub>CC</sub> = 2.0 V		50	μA
		Write	V <sub>CC</sub> = 2.0 V		150	μA
C <sub>TUN</sub>	Internal tuning capacitor <sup>(2)</sup>	f = 13.56 MHz	24.8	27.5	30.2	pF

1. T<sub>A</sub> = -40 to 85 °C.

2. Characterised only, at room temperature only, measured at V<sub>AC0-AC1</sub> = 0.5 V peak.

**Table 96. Operating conditions**

Symbol	Parameter	Min.	Max.	Unit
T <sub>A</sub>	Ambient operating temperature	-40	85	°C

Figure 60 shows an ASK modulated signal, from the VCD to the LRIS64K. The test condition for the AC/DC parameters are:

- Close coupling condition with tester antenna (1mm)
- LRIS64K performance measured at the tag antenna

**Figure 60. LRIS64K synchronous timing, transmit and receive**

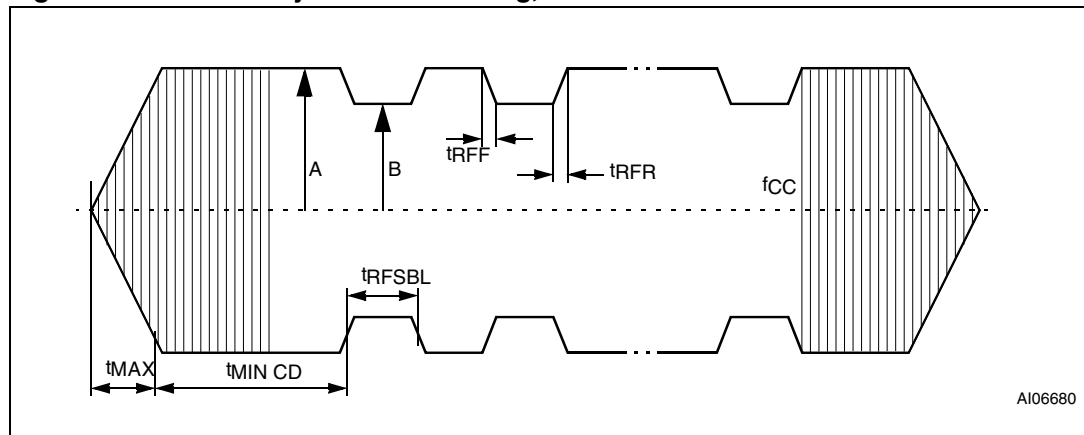

## 27 Part numbering

**Table 97. Ordering information scheme**

Example:	LRIS64K -	SBN18/	2
<b>Device type</b>			
LRIS64K (long-range tag with 64 Kbit EEPROM)			
<b>Package</b>			
SBN18 = 180 μm ± 15 μm bumped and sawn wafer on 8-inch frame			
<b>Tuning capacitance</b>			
2= 27.5 pF			

For a list of available options (speed, package, etc.) or for further information on any aspect of this device, please contact your nearest ST sales office.

## Appendix A Anticollision algorithm

The following pseudocode describes how anticollision could be implemented on the VCD, using recursivity.

### A.1 Algorithm for pulsed slots

```

function push (mask, address); pushes on private stack
function pop (mask, address); pops from private stack
function pulse_next_pause; generates a power pulse
function store(LRIS64K_UID); stores LRIS64K_UID

function poll_loop (sub_address_size as integer)
  pop (mask, address)
  mask = address & mask; generates new mask
    ; send the request
  mode = anticollision
  send_Request (Request_cmd, mode, mask length, mask value)
  for sub_address = 0 to (2^sub_address_size - 1)
    pulse_next_pause
    if no_collision_is_detected ; LRIS64K is inventoried
      then
        store (LRIS64K_UID)
      else ; remember a collision was detected
        push(mask,address)
      endif
    next sub_address

    if stack_not_empty ; if some collisions have been detected and
      then ; not yet processed, the function calls itself
        poll_loop (sub_address_size); recursively to process the
last stored collision
      endif
end poll_loop

main_cycle:
  mask = null
  address = null
  push (mask, address)
  poll_loop(sub_address_size)
end_main_cycle

```

## Appendix B CRC

### B.1 CRC error detection method

The cyclic redundancy check (CRC) is calculated on all data contained in a message, from the start of the flags through to the end of Data. The CRC is used from VCD to LRIS64K and from LRIS64K to VCD.

**Table 98. CRC definition**

CRC definition					
CRC type	Length	Polynomial	Direction	Preset	Residue
ISO/IEC 13239	16 bits	$X^{16} + X^{12} + X^5 + 1 = 8408h$	Backward	FFFFh	F0B8h

To add extra protection against shifting errors, a further transformation on the calculated CRC is made. The One's Complement of the calculated CRC is the value attached to the message for transmission.

To check received messages the 2 CRC bytes are often also included in the re-calculation, for ease of use. In this case, the expected value for the generated CRC is the residue F0B8h.

### B.2 CRC calculation example

This example in C language illustrates one method of calculating the CRC on a given set of bytes comprising a message.

#### C-example to calculate or check the CRC16 according to ISO/IEC 13239

```
#define POLYNOMIAL0x8408// x^16 + x^12 + x^5 + 1
#define PRESET_VALUE0xFFFF
#define CHECK_VALUE0xF0B8

#define NUMBER_OF_BYTES4// Example: 4 data bytes
#define CALC_CRC1
#define CHECK_CRC0

void main()
{
    unsigned int current_crc_value;
    unsigned char array_of_databytes[NUMBER_OF_BYTES + 2] = {1, 2, 3,
4, 0x91, 0x39};
    int number_of_databytes = NUMBER_OF_BYTES;
    int calculate_or_check_crc;
    int i, j;
    calculate_or_check_crc = CALC_CRC;
    // calculate_or_check_crc = CHECK_CRC;// This could be an other
example
    if (calculate_or_check_crc == CALC_CRC)
    {
```

```

        number_of_databytes = NUMBER_OF_BYTES;
    }
    else    // check CRC
    {
        number_of_databytes = NUMBER_OF_BYTES + 2;
    }

    current_crc_value = PRESET_VALUE;

    for (i = 0; i < number_of_databytes; i++)
    {
        current_crc_value = current_crc_value ^ ((unsigned
int)array_of_databytes[i]);

        for (j = 0; j < 8; j++)
        {
            if (current_crc_value & 0x0001)
            {
                current_crc_value = (current_crc_value >> 1) ^
POLYNOMIAL;
            }
            else
            {
                current_crc_value = (current_crc_value >> 1);
            }
        }
    }

    if (calculate_or_check_crc == CALC_CRC)
    {
        current_crc_value = ~current_crc_value;

        printf ("Generated CRC is 0x%04X\n", current_crc_value);

        // current_crc_value is now ready to be appended to the data
stream
        // (first LSByte, then MSByte)
    }
    else    // check CRC
    {
        if (current_crc_value == CHECK_VALUE)
        {
            printf ("Checked CRC is ok (0x%04X)\n",
current_crc_value);
        }
        else
        {
            printf ("Checked CRC is NOT ok (0x%04X)\n",
current_crc_value);
        }
    }
}

```

## Appendix C Application family identifier (AFI)

The AFI (application family identifier) represents the type of application targeted by the VCD and is used to extract from all the LRIS64K present only the LRIS64K meeting the required application criteria.

It is programmed by the LRIS64K issuer (the purchaser of the LRIS64K). Once locked, it cannot be modified.

The most significant nibble of the AFI is used to code one specific or all application families, as defined in [Table 99](#).

The least significant nibble of the AFI is used to code one specific or all application subfamilies. Subfamily codes different from 0 are proprietary.

**Table 99. AFI coding<sup>(1)</sup>**

AFI Most significant nibble	AFI Least significant nibble	Meaning VICCs respond from	Examples / Note
'0'	'0'	All families and subfamilies	No applicative preselection
'X'	'0'	'All subfamilies of family X	Wide applicative preselection
'X	"Y'	Only the Yth subfamily of family X	
'0'	'Y'	Proprietary subfamily Y only	
'1	"0', 'Y'	Transport	Mass transit, bus, airline, etc.
'2	"0', 'Y'	Financial	IEP, banking, retail, etc.
'3	"0', 'Y'	Identification	Access control, etc.
'4	"0', 'Y'	Telecommunication	Public telephony, GSM, etc.
'5'	'0', 'Y'	Medical	
'6	"0', 'Y'	Multimedia	Internet services, etc.
'7	"0', 'Y'	Gaming	
8	"0', 'Y'	Data storage	Portable files, etc.
'9	"0', 'Y'	Item management	
'A	"0', 'Y'	Express parcels	
'B	"0', 'Y'	Postal services	
'C	"0', 'Y'	Airline bags	
'D	"0', 'Y'	RFU	
'E	"0', 'Y'	RFU	
'F'	'0', 'Y'	RFU	

1. X = '1' to 'F', Y = '1' to 'F'

## Revision history

**Table 100. Document revision history**

Date	Revision	Changes
26-Jan-2009	1	Initial release.
05-Feb-2009	2	TSSOP8 package removed. Wafer silhouette added <a href="#">on page 1</a> .
13-Feb-2009	3	Device programming time corrected.
02-Apr-2009	4	Revision history corrected (revision 3 added). Figure 2: UFDFPN8 connections corrected.
16-Jul-2009	5	Document status promoted from Target specification to Preliminary data. $V_{ESD}$ modified in <a href="#">Table 93: Absolute maximum ratings</a> .
17-Sep-2009	6	$V_{ESD}$ modified in <a href="#">Table 93: Absolute maximum ratings</a> .
25-Aug-2010	7	Updated <a href="#">Features on page 1</a> . Removed all references to packages. Removed Figure 2: UFDFPN8 connections. Updated <a href="#">Section 4: Initial delivery state on page 18</a> . Updated <a href="#">Figure 3</a> , <a href="#">Figure 4</a> , <a href="#">Table 94</a> , and <a href="#">Table 95</a> . Updated storage time ( $t_{STG}$ ) in <a href="#">Table 93: Absolute maximum ratings on page 91</a> .
05-Oct-2010	8	Document classification changed to public. Updated DSFID value in <a href="#">Section 4: Initial delivery state</a>
08-Nov-2010	9	Updated document status from preliminary status to public.
19-Sep-2011	10	Modified <a href="#">Section 1: Description</a> Updated disclaimer on last page.
27-Oct-2011	11	Updated footnote <sup>(2)</sup> of <a href="#">Table 94: RF AC characteristics</a> .

**Please Read Carefully:**

Information in this document is provided solely in connection with ST products. STMicroelectronics NV and its subsidiaries ("ST") reserve the right to make changes, corrections, modifications or improvements, to this document, and the products and services described herein at any time, without notice.

All ST products are sold pursuant to ST's terms and conditions of sale.

Purchasers are solely responsible for the choice, selection and use of the ST products and services described herein, and ST assumes no liability whatsoever relating to the choice, selection or use of the ST products and services described herein.

No license, express or implied, by estoppel or otherwise, to any intellectual property rights is granted under this document. If any part of this document refers to any third party products or services it shall not be deemed a license grant by ST for the use of such third party products or services, or any intellectual property contained therein or considered as a warranty covering the use in any manner whatsoever of such third party products or services or any intellectual property contained therein.

**UNLESS OTHERWISE SET FORTH IN ST'S TERMS AND CONDITIONS OF SALE ST DISCLAIMS ANY EXPRESS OR IMPLIED WARRANTY WITH RESPECT TO THE USE AND/OR SALE OF ST PRODUCTS INCLUDING WITHOUT LIMITATION IMPLIED WARRANTIES OF MERCHANTABILITY, FITNESS FOR A PARTICULAR PURPOSE (AND THEIR EQUIVALENTS UNDER THE LAWS OF ANY JURISDICTION), OR INFRINGEMENT OF ANY PATENT, COPYRIGHT OR OTHER INTELLECTUAL PROPERTY RIGHT.**

**UNLESS EXPRESSLY APPROVED IN WRITING BY TWO AUTHORIZED ST REPRESENTATIVES, ST PRODUCTS ARE NOT RECOMMENDED, AUTHORIZED OR WARRANTED FOR USE IN MILITARY, AIR CRAFT, SPACE, LIFE SAVING, OR LIFE SUSTAINING APPLICATIONS, NOR IN PRODUCTS OR SYSTEMS WHERE FAILURE OR MALFUNCTION MAY RESULT IN PERSONAL INJURY, DEATH, OR SEVERE PROPERTY OR ENVIRONMENTAL DAMAGE. ST PRODUCTS WHICH ARE NOT SPECIFIED AS "AUTOMOTIVE GRADE" MAY ONLY BE USED IN AUTOMOTIVE APPLICATIONS AT USER'S OWN RISK.**

Resale of ST products with provisions different from the statements and/or technical features set forth in this document shall immediately void any warranty granted by ST for the ST product or service described herein and shall not create or extend in any manner whatsoever, any liability of ST.

ST and the ST logo are trademarks or registered trademarks of ST in various countries.

Information in this document supersedes and replaces all information previously supplied.

The ST logo is a registered trademark of STMicroelectronics. All other names are the property of their respective owners.

© 2011 STMicroelectronics - All rights reserved

STMicroelectronics group of companies

Australia - Belgium - Brazil - Canada - China - Czech Republic - Finland - France - Germany - Hong Kong - India - Israel - Italy - Japan - Malaysia - Malta - Morocco - Philippines - Singapore - Spain - Sweden - Switzerland - United Kingdom - United States of America

[www.st.com](http://www.st.com)