



M950x0 M950x0-W M950x0-R

4 Kbit, 2 Kbit and 1 Kbit serial SPI bus EEPROM
with high-speed clock

Features

- Compatible with SPI bus serial interface (Positive clock SPI modes)
- Single supply voltage:
 - 4.5 V to 5.5 V for M950x0
 - 2.5 V to 5.5 V for M950x0-W
 - 1.8 V to 5.5 V for M950x0-R
- High speed
 - 10 MHz Clock rate, 5 ms write time
- Status Register
- Byte and Page Write (up to 16 bytes)
- Self-timed programming cycle
- Adjustable size read-only EEPROM area
- Enhanced ESD protection
- More than 1 Million write cycles
- More than 40-year data retention
- Packages
 - RoHS-compliant and Halogen-free (ECOPACK2®)

Table 1. Device summary

Reference	Part number
M95040	M95040
	M95040-W
	M95040-R
M95020	M95020
	M95020-W
	M95020-R
M95010	M95010
	M95010-W
	M95010-R



SO8 (MN)
150 mil width



TSSOP8 (DW)
169 mil width



UFD8 (MB or MC)
2 × 3 mm

Contents

- 1 Description 6**
- 2 Signal description 8**
 - 2.1 Serial Data output (Q) 8
 - 2.2 Serial Data input (D) 8
 - 2.3 Serial Clock (C) 8
 - 2.4 Chip Select (\overline{S}) 8
 - 2.5 Hold (\overline{HOLD}) 8
 - 2.6 Write Protect (\overline{W}) 9
 - 2.7 V_{SS} ground 9
 - 2.8 Supply voltage (V_{CC}) 9
 - 2.9 Supply voltage (V_{CC}) 9
 - 2.9.1 Operating supply voltage V_{CC} 9
 - 2.9.2 Device reset 9
 - 2.9.3 Power-up conditions 10
 - 2.9.4 Power-down 10
- 3 Connecting to the SPI bus 11**
 - 3.1 SPI modes 12
- 4 Operating features 13**
 - 4.1 Hold condition 13
 - 4.2 Status register 13
 - 4.3 Data protection and protocol control 14
- 5 Memory organization 15**
- 6 Instructions 16**
 - 6.1 Write Enable (WREN) 16
 - 6.2 Write Disable (WRDI) 17
 - 6.3 Read Status Register (RDSR) 18
 - 6.3.1 WIP bit 18
 - 6.3.2 WEL bit 18

6.3.3	BP1, BP0 bits	18
6.4	Write Status Register (WRSR)	20
6.5	Read from Memory Array (READ)	22
6.6	Write to Memory Array (WRITE)	23
7	Power-up and delivery states	25
7.1	Power-up state	25
7.2	Initial delivery state	25
8	Maximum rating	26
9	DC and AC parameters	27
10	Package mechanical data	37
11	Part numbering	40
12	Revision history	41

List of tables

Table 1.	Device summary	1
Table 2.	Signal names	7
Table 3.	Write-protected block size	14
Table 4.	Instruction set	16
Table 5.	Status register format	18
Table 6.	Address range bits	22
Table 7.	Absolute maximum ratings	26
Table 8.	Operating conditions (M950x0)	27
Table 9.	Operating conditions (M950x0-W)	27
Table 10.	Operating conditions (M950x0-R)	27
Table 11.	AC test measurement conditions	27
Table 12.	Capacitance	28
Table 13.	DC characteristics (M950x0, device grade 3)	28
Table 14.	DC characteristics (M950x0-W, device grade 6)	29
Table 15.	DC characteristics (M950x0-W, device grade 3)	30
Table 16.	DC characteristics (M950x0-R, device grade 6)	30
Table 17.	AC characteristics (M950x0, device grade 3)	31
Table 18.	AC characteristics (M950x0-W, device grade 6)	32
Table 19.	AC characteristics (M950x0-W, device grade 3)	33
Table 20.	AC characteristics (M950x0-R, device grade 6)	34
Table 21.	SO8N — 8-lead plastic small outline, 150 mils body width, package mechanical data	37
Table 22.	TSSOP8 — 8-lead thin shrink small outline, package mechanical data	38
Table 23.	UFDFPN8 (MLP8) 8-lead ultra thin fine pitch dual flat package no lead 2 × 3mm, data	39
Table 24.	Ordering information scheme	40
Table 25.	Document revision history	41

List of figures

Figure 1.	Logic diagram	6
Figure 2.	8-pin package connections	6
Figure 3.	Bus master and memory devices on the SPI bus	11
Figure 4.	SPI modes supported	12
Figure 5.	Hold condition activation	13
Figure 6.	Block diagram	15
Figure 7.	Write Enable (WREN) sequence	16
Figure 8.	Write Disable (WRDI) sequence	17
Figure 9.	Read Status Register (RDSR) sequence	19
Figure 10.	Write Status Register (WRSR) sequence	20
Figure 11.	Read from Memory Array (READ) sequence	22
Figure 12.	Byte Write (WRITE) sequence	23
Figure 13.	Page Write (WRITE) sequence	24
Figure 14.	AC test measurement I/O waveform	28
Figure 15.	Serial input timing	35
Figure 16.	Hold timing	35
Figure 17.	Serial output timing	36
Figure 18.	SO8N — 8-lead plastic small outline 150 mils body width, package outline	37
Figure 19.	TSSOP8 — 8-lead thin shrink small outline, package outline	38
Figure 20.	UFDFPN8 (MLP8) 8-lead ultra thin fine pitch dual flat package no lead 2 × 3mm, outline	39

1 Description

The M95040 is a 4 Kbit (512 x 8) electrically erasable programmable memory (EEPROM), accessed by a high-speed SPI-compatible bus. The other members of the family (M95020 and M95010) are identical, though proportionally smaller (2 and 1 Kbit, respectively).

Each device is accessed by a simple serial interface that is SPI-compatible. The bus signals are C, D and Q.

The device is selected when Chip Select (\bar{S}) is taken low. Communications with the device can be interrupted using Hold (\overline{HOLD}). WRITE instructions are disabled by Write Protect (\bar{W}).

Figure 1. Logic diagram

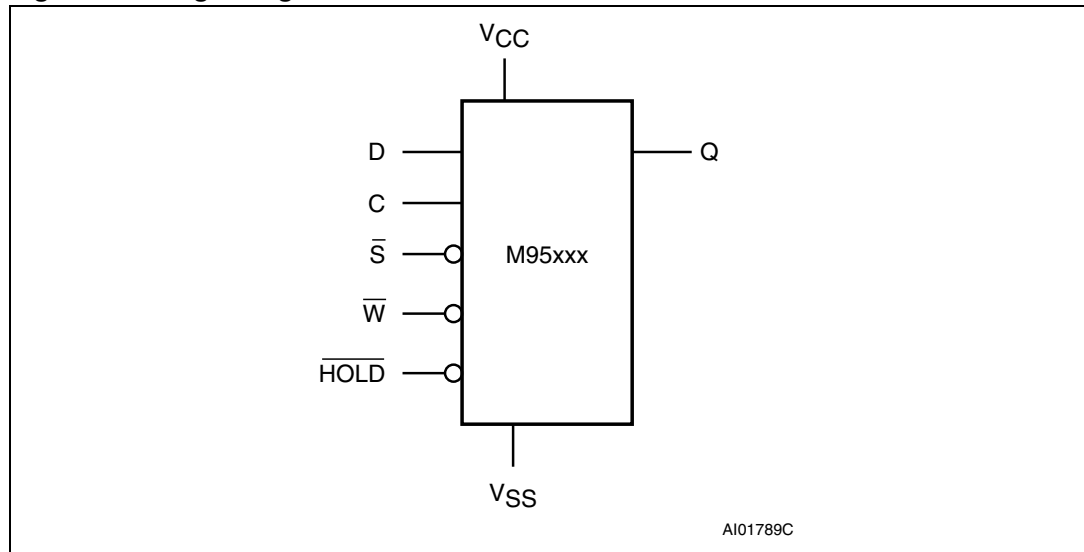
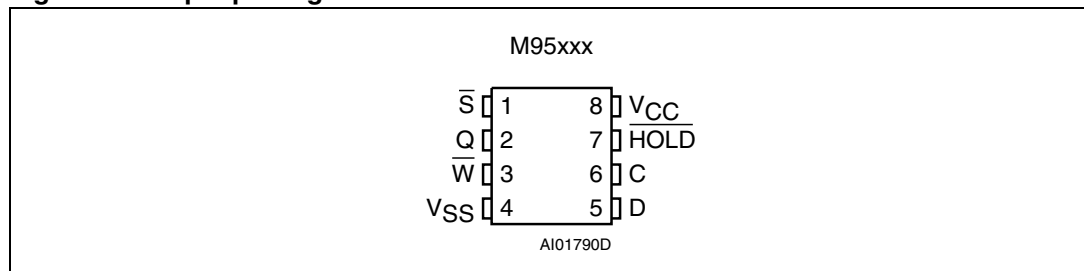

Figure 2. 8-pin package connections



1. See [Section 10: Package mechanical data](#) for package dimensions, and how to identify pin-1.

Table 2. Signal names

Signal name	Function
C	Serial Clock
D	Serial Data input
Q	Serial Data output
\overline{S}	Chip Select
\overline{W}	Write Protect
\overline{HOLD}	Hold
V _{CC}	Supply voltage
V _{SS}	Ground

2 Signal description

During all operations, V_{CC} must be held stable and within the specified valid range: $V_{CC}(\min)$ to $V_{CC}(\max)$.

All of the input and output signals can be held high or low (according to voltages of V_{IH} , V_{OH} , V_{IL} or V_{OL} , as specified in [Table 13: DC characteristics \(M950x0, device grade 3\)](#) to [Table 16: DC characteristics \(M950x0-R, device grade 6\)](#)). These signals are described next.

2.1 Serial Data output (Q)

This output signal is used to transfer data serially out of the device. Data is shifted out on the falling edge of Serial Clock (C).

2.2 Serial Data input (D)

This input signal is used to transfer data serially into the device. It receives instructions, addresses, and the data to be written. Values are latched on the rising edge of Serial Clock (C).

2.3 Serial Clock (C)

This input signal provides the timing of the serial interface. Instructions, addresses, or data present at Serial Data Input (D) are latched on the rising edge of Serial Clock (C). Data on Serial Data Output (Q) changes after the falling edge of Serial Clock (C).

2.4 Chip Select (\overline{S})

When this input signal is high, the device is deselected and Serial Data Output (Q) is at high impedance. Unless an internal Write cycle is in progress, the device will be in the Standby Power mode. Driving Chip Select (\overline{S}) low selects the device, placing it in the Active Power mode.

After Power-up, a falling edge on Chip Select (\overline{S}) is required prior to the start of any instruction.

2.5 Hold (\overline{HOLD})

The Hold (\overline{HOLD}) signal is used to pause any serial communications with the device without deselecting the device.

During the Hold condition, the Serial Data Output (Q) is high impedance, and Serial Data Input (D) and Serial Clock (C) are Don't Care.

To start the Hold condition, the device must be selected, with Chip Select (\overline{S}) driven low.

2.6 Write Protect (\overline{W})

This input signal is used to control whether the memory is write protected. When Write Protect (\overline{W}) is held low, writes to the memory are disabled, but other operations remain enabled. Write Protect (\overline{W}) must either be driven high or low, but must not be left floating.

2.7 V_{SS} ground

V_{SS} is the reference for the V_{CC} supply voltage.

2.8 Supply voltage (V_{CC})

2.9 Supply voltage (V_{CC})

2.9.1 Operating supply voltage V_{CC}

Prior to selecting the memory and issuing instructions to it, a valid and stable V_{CC} voltage within the specified [$V_{CC}(\text{min})$, $V_{CC}(\text{max})$] range must be applied (see [Table 8: Operating conditions \(M950x0\)](#), [Table 9: Operating conditions \(M950x0-W\)](#) and [Table 10: Operating conditions \(M950x0-R\)](#)). This voltage must remain stable and valid until the end of the transmission of the instruction and, for a Write instruction, until the completion of the internal write cycle (t_W). In order to secure a stable DC supply voltage, it is recommended to decouple the V_{CC} line with a suitable capacitor (usually of the order of 10 nF to 100 nF) close to the V_{CC}/V_{SS} package pins.

2.9.2 Device reset

In order to prevent inadvertent write operations during power-up, a power-on-reset (POR) circuit is included. At power-up, the device does not respond to any instruction until V_{CC} reaches the internal reset threshold voltage (this threshold is defined in [Table 8: Operating conditions \(M950x0\)](#), [Table 9: Operating conditions \(M950x0-W\)](#) and [Table 10: Operating conditions \(M950x0-R\)](#) as V_{RES}).

When V_{CC} passes over the POR threshold, the device is reset and is in the following state:

- in Standby Power mode
- deselected (note that, to be executed, an instruction must be preceded by a falling edge on Chip Select (\overline{S}))
- Status register value:
 - the Write Enable Latch (WEL) is reset to 0
 - Write In Progress (WIP) is reset to 0
 - The SRWD, BP1 and BP0 bits remain unchanged (non-volatile bits)

When V_{CC} passes over the POR threshold, the device is reset and enters the Standby Power mode. The device must not be accessed until V_{CC} reaches a valid and stable V_{CC} voltage within the specified [$V_{CC}(\text{min})$, $V_{CC}(\text{max})$] range defined in [Table 8: Operating conditions \(M950x0\)](#), [Table 9: Operating conditions \(M950x0-W\)](#) and [Table 10: Operating conditions \(M950x0-R\)](#).

2.9.3 Power-up conditions

When the power supply is turned on, V_{CC} rises continuously from V_{SS} to V_{CC} . During this time, the Chip Select (\overline{S}) line is not allowed to float but should follow the V_{CC} voltage. It is therefore recommended to connect the \overline{S} line to V_{CC} via a suitable pull-up resistor (see [Figure 3: Bus master and memory devices on the SPI bus](#)).

In addition, the Chip Select (\overline{S}) input offers a built-in safety feature, as the \overline{S} input is edge sensitive as well as level sensitive: after power-up, the device does not become selected until a falling edge has first been detected on Chip Select (\overline{S}). This ensures that Chip Select (\overline{S}) must have been high, prior to going low to start the first operation.

The V_{CC} voltage has to rise continuously from 0 V up to the minimum V_{CC} operating voltage defined in [Table 8: Operating conditions \(M950x0\)](#), [Table 9: Operating conditions \(M950x0-W\)](#) and [Table 10: Operating conditions \(M950x0-R\)](#) and the rise time must not vary faster than 1 V/ μ s.

2.9.4 Power-down

During power-down (continuous decrease in the V_{CC} supply voltage below the minimum V_{CC} operating voltage defined in [Table 8: Operating conditions \(M950x0\)](#), [Table 9: Operating conditions \(M950x0-W\)](#) and [Table 10: Operating conditions \(M950x0-R\)](#)), the device must be:

- deselected (Chip Select \overline{S} should be allowed to follow the voltage applied on V_{CC})
- in Standby Power mode (there should not be any internal write cycle in progress).

3 Connecting to the SPI bus

The device is fully compatible with the SPI protocol.

All instructions, addresses and input data bytes are shifted in to the device, most significant bit first. The Serial Data Input (D) is sampled on the first rising edge of the Serial Clock (C) after Chip Select (\bar{S}) goes low.

All output data bytes are shifted out of the device, most significant bit first. The Serial Data Output (Q) is latched on the first falling edge of the Serial Clock (C) after the instruction (such as the Read from Memory Array and Read Status Register instructions) have been clocked into the device.

Figure 3: Bus master and memory devices on the SPI bus shows an example of three memory devices connected to an MCU, on an SPI bus. Only one memory device is selected at a time, so only one memory device drives the Serial Data output (Q) line at a time, the other memory devices are high impedance.

The pull-up resistor R (represented in *Figure 3: Bus master and memory devices on the SPI bus*) ensures that a device is not selected if the bus master leaves the \bar{S} line in the high impedance state.

In applications where the bus master might enter a state where all SPI bus inputs/outputs would be in high impedance at the same time (for example, if the bus master is reset during the transmission of an Instruction), the clock line (C) must be connected to an external pull-down resistor so that, if all inputs/outputs become high impedance, the C line is pulled low (while the \bar{S} line is pulled high): this ensures that \bar{S} and C do not become high at the same time, and so, that the t_{SHCH} requirement is met. The typical value of R is 100 k Ω .

Figure 3. Bus master and memory devices on the SPI bus

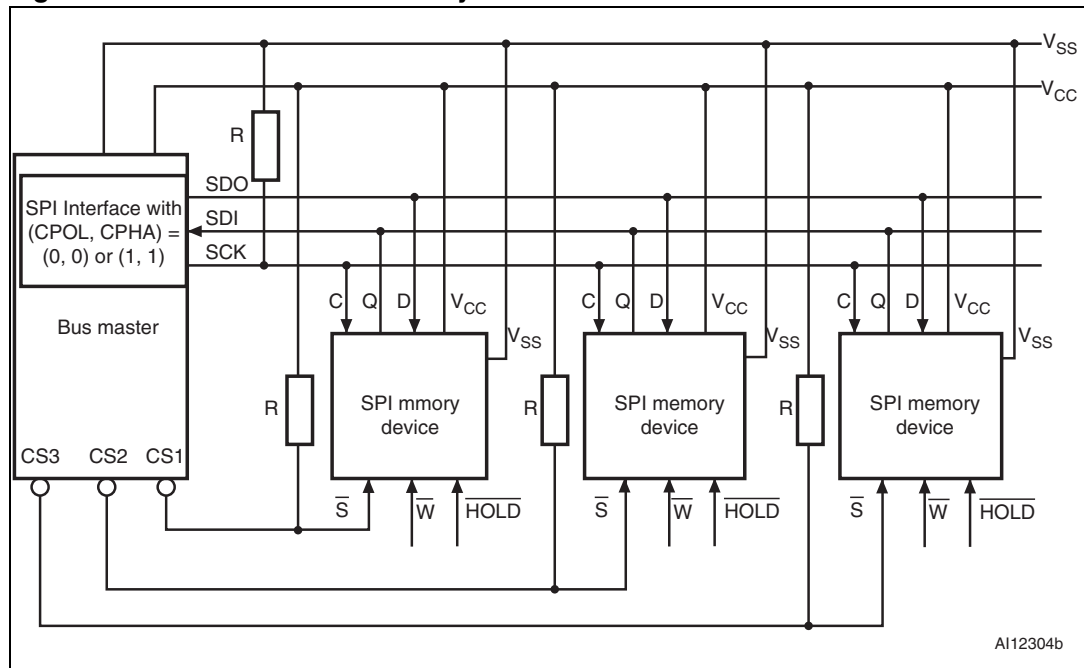

1. The Write Protect (\bar{W}) and Hold (\overline{HOLD}) signals should be driven, high or low as appropriate.

3.1 SPI modes

The device can be driven by a microcontroller with its SPI peripheral running in either of the two following modes:

- CPOL=0, CPHA=0
- CPOL=1, CPHA=1

For these two modes, input data is latched in on the rising edge of Serial Clock (C), and output data is available from the falling edge of Serial Clock (C).

The difference between the two modes, as shown in *Figure 4: SPI modes supported*, is the clock polarity when the bus master is in Stand-by mode and not transferring data:

- C remains at 0 for (CPOL=0, CPHA=0)
- C remains at 1 for (CPOL=1, CPHA=1)

Figure 4. SPI modes supported

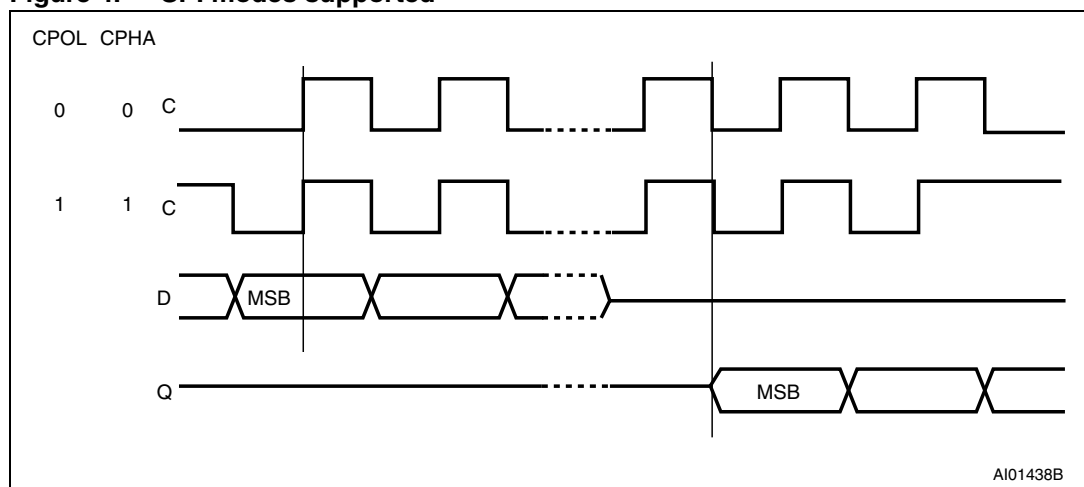

4 Operating features

4.1 Hold condition

The Hold ($\overline{\text{HOLD}}$) signal is used to pause any serial communications with the device without resetting the clocking sequence.

During the Hold condition, the Serial Data Output (Q) is high impedance, and Serial Data Input (D) and Serial Clock (C) are Don't Care.

To enter the Hold condition, the device must be selected, with Chip Select ($\overline{\text{S}}$) low.

Normally, the device is kept selected, for the whole duration of the Hold condition. Deselecting the device while it is in the Hold condition has the effect of resetting the state of the device, and this mechanism can be used if it is required to reset any processes that had been in progress.

The Hold condition starts when the Hold ($\overline{\text{HOLD}}$) signal is driven low at the same time as Serial Clock (C) already being low (as shown in [Figure 5: Hold condition activation](#)).

The Hold condition ends when the Hold ($\overline{\text{HOLD}}$) signal is driven high at the same time as Serial Clock (C) already being low.

[Figure 5: Hold condition activation](#) also shows what happens if the rising and falling edges are not timed to coincide with Serial Clock (C) being low.

Figure 5. Hold condition activation

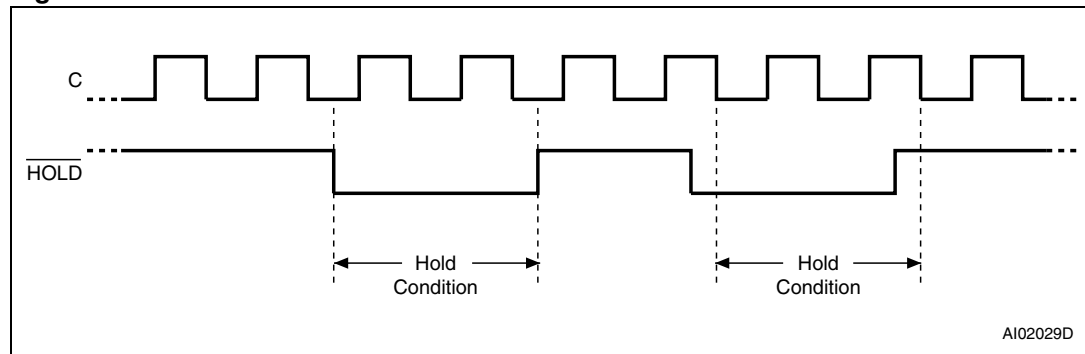

4.2 Status register

[Figure 6: Block diagram](#) shows the position of the Status register in the control logic of the device. This register contains a number of control bits and status bits, as shown in [Table 5: Status register format](#). For a detailed description of the Status register bits, see [Section 6.3: Read Status Register \(RDSR\)](#).

4.3 Data protection and protocol control

To help protect the device from data corruption in noisy or poorly controlled environments, a number of safety features have been built in to the device. The main security measures can be summarized as follows:

- The WEL bit is reset at power-up.
- Chip Select (\overline{S}) must rise after the eighth clock count (or multiple thereof) in order to start a non-volatile Write cycle (in the memory array or in the Status register).
- Accesses to the memory array are ignored during the non-volatile programming cycle, and the programming cycle continues unaffected.
- Invalid Chip Select (\overline{S}) and Hold (\overline{HOLD}) transitions are ignored.

For any instruction to be accepted and executed, Chip Select (\overline{S}) must be driven high after the rising edge of Serial Clock (C) that latches the last bit of the instruction, and before the next rising edge of Serial Clock (C).

For this, “the last bit of the instruction” can be the eighth bit of the instruction code, or the eighth bit of a data byte, depending on the instruction (except in the case of RDSR and READ instructions). Moreover, the “next rising edge of CLOCK” might (or might not) be the next bus transaction for some other device on the bus.

When a Write cycle is in progress, the device protects it against external interruption by ignoring any subsequent READ, WRITE or WRSR instruction until the present cycle is complete.

Table 3. Write-protected block size

Status register bits		Protected block	Protected array addresses		
BP1	BP0		M95040	M95020	M95010
0	0	none	none	none	none
0	1	Upper quarter	180h - 1FFh	C0h - FFh	60h - 7Fh
1	0	Upper half	100h - 1FFh	80h - FFh	40h - 7Fh
1	1	Whole memory	000h - 1FFh	00h - FFh	00h - 7Fh

5 Memory organization

The memory is organized as shown in *Figure 6: Block diagram*.

Figure 6. Block diagram

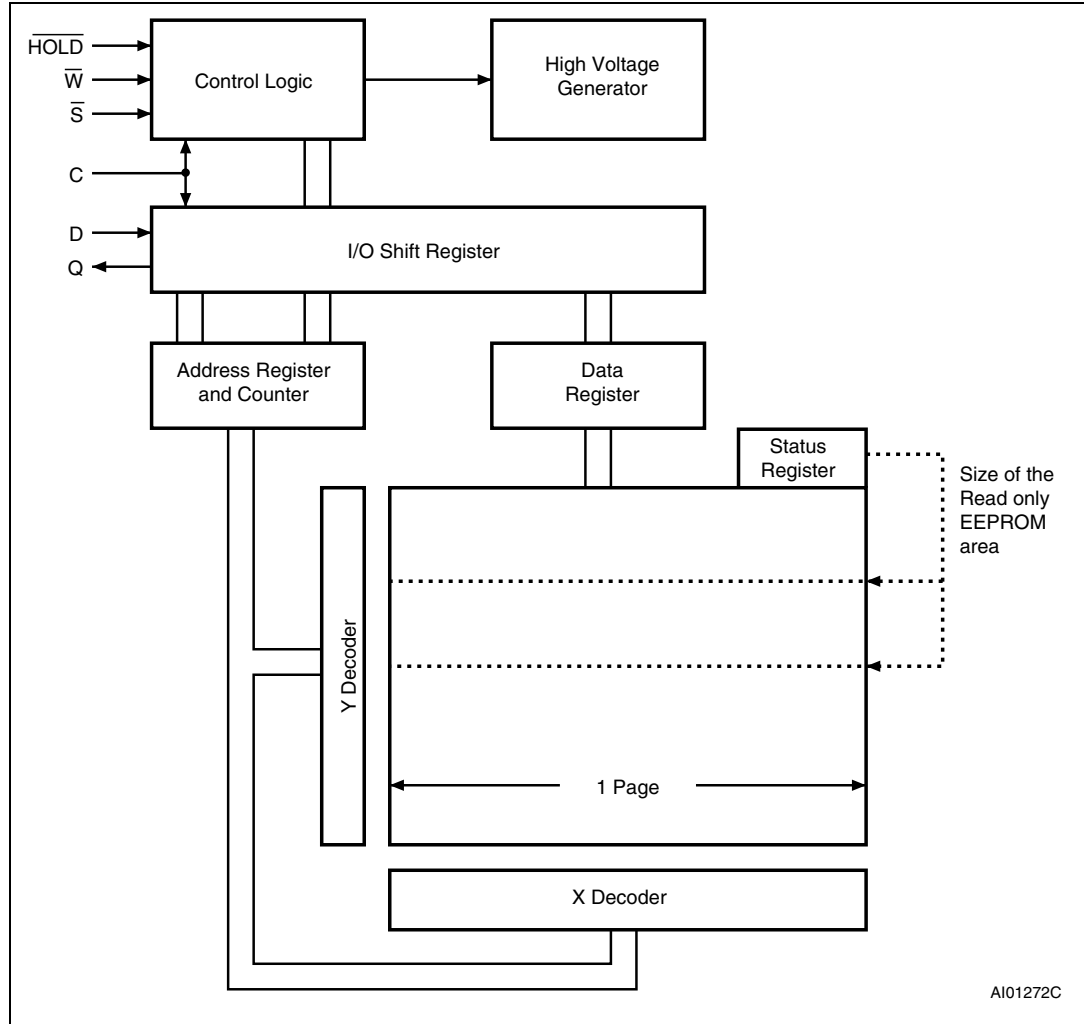

6 Instructions

Each instruction starts with a single-byte code, as summarized in [Table 4: Instruction set](#).

If an invalid instruction is sent (one not contained in [Table 4: Instruction set](#)), the device automatically deselects itself.

Table 4. Instruction set

Instruction	Description	Instruction Format
WREN	Write Enable	0000 X110 ⁽¹⁾
WRDI	Write Disable	0000 X100 ⁽¹⁾
RDSR	Read Status Register	0000 X101 ⁽¹⁾
WRSR	Write Status Register	0000 X001 ⁽¹⁾
READ	Read from Memory Array	0000 A ₈ 011 ⁽²⁾
WRITE	Write to Memory Array	0000 A ₈ 010 ⁽²⁾

1. X = Don't Care.
2. A₈ = 1 for the upper half of the memory array of the M95040, and 0 for the lower half, and is Don't Care for other devices.

6.1 Write Enable (WREN)

The Write Enable Latch (WEL) bit must be set prior to each WRITE and WRSR instruction. The only way to do this is to send a Write Enable instruction to the device.

As shown in [Figure 7: Write Enable \(WREN\) sequence](#), to send this instruction to the device, Chip Select (\bar{S}) is driven low, and the bits of the instruction byte are shifted in, on Serial Data Input (D). The device then enters a wait state. It waits for the device to be deselected, by Chip Select (\bar{S}) being driven high.

Figure 7. Write Enable (WREN) sequence

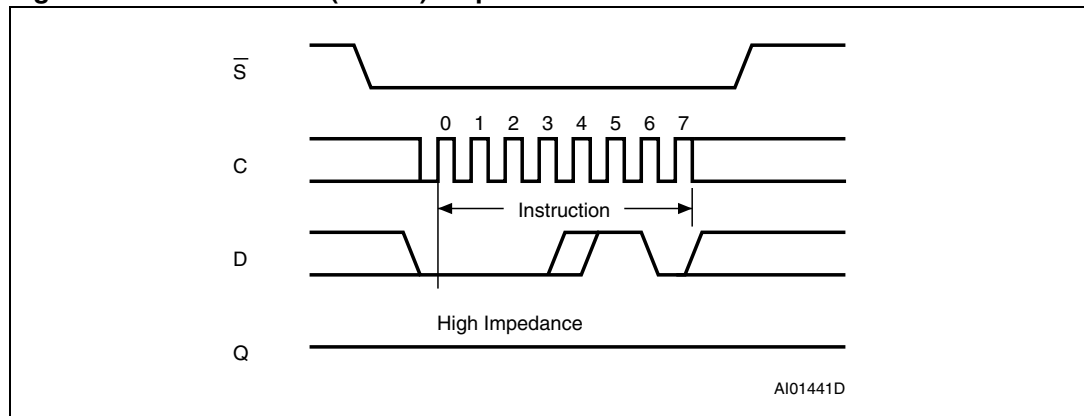

6.2 Write Disable (WRDI)

One way of resetting the Write Enable Latch (WEL) bit is to send a Write Disable instruction to the device.

As shown in [Figure 8: Write Disable \(WRDI\) sequence](#), to send this instruction to the device, Chip Select (\overline{S}) is driven low, and the bits of the instruction byte are shifted in, on Serial Data Input (D).

The device then enters a wait state. It waits for a the device to be deselected, by Chip Select (\overline{S}) being driven high.

The Write Enable Latch (WEL) bit, in fact, becomes reset by any of the following events:

- Power-up
- WRDI instruction execution
- WRSR instruction completion
- WRITE instruction completion
- Write Protect (\overline{W}) line being held low.

Figure 8. Write Disable (WRDI) sequence

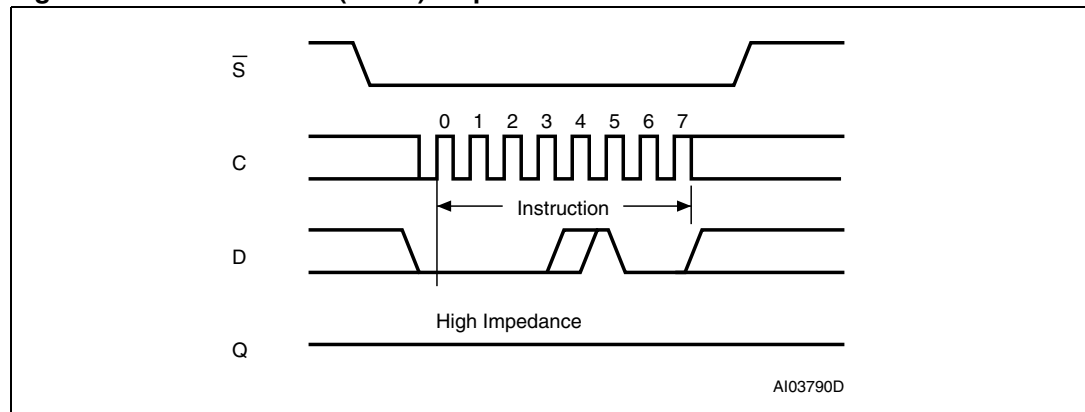

6.3 Read Status Register (RDSR)

The Read Status Register instruction is used to read the Status Register.

As shown in [Figure 9](#), to send this instruction to the device, Chip Select (\bar{S}) is first driven low. The bits of the instruction byte are then shifted in, on Serial Data Input (D). The current state of the bits in the Status register is shifted out, on Serial Data Out (Q). The Read Cycle is terminated by driving Chip Select (\bar{S}) high.

The Status Register is always readable, even if a Write or Write Status Register cycle is in progress. During a Write Status Register cycle, the values of the non-volatile bits (BP0, BP1) become available when a new RDSR instruction is executed, after completion of the Write cycle. On the other hand, the two read-only bits (Write Enable Latch (WEL), Write In Progress (WIP)) are dynamically updated during the ongoing Write cycle.

It is also possible to read the Status Register contents continuously, as described in [Figure 9](#).

Bits b7, b6, b5 and b4 are always read as 1. The status and control bits of the Status register are as follows:

Table 5. Status register format

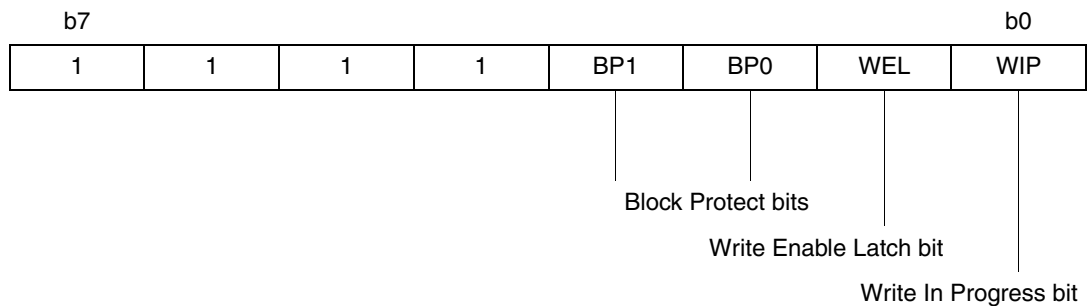

6.3.1 WIP bit

The Write In Progress (WIP) bit indicates whether the memory is busy with a Write or Write Status register cycle. When set to 1, such a cycle is in progress, when reset to 0 no such cycle is in progress.

6.3.2 WEL bit

The Write Enable Latch (WEL) bit indicates the status of the internal Write Enable Latch. When set to 1 the internal Write Enable Latch is set, when set to 0 the internal Write Enable Latch is reset and no Write or Write Status Register instruction is accepted.

6.3.3 BP1, BP0 bits

The Block Protect (BP1, BP0) bits are non-volatile. They define the size of the area to be software protected against Write instructions. These bits are written with the Write Status Register (WRSR) instruction. When one or both of the Block Protect (BP1, BP0) bits is set to 1, the relevant memory area (as defined in [Table 3: Write-protected block size](#)) becomes protected against Write (WRITE) instructions. The Block Protect (BP1, BP0) bits can be written provided that the Hardware Protected mode has not been set.

Figure 9. Read Status Register (RDSR) sequence

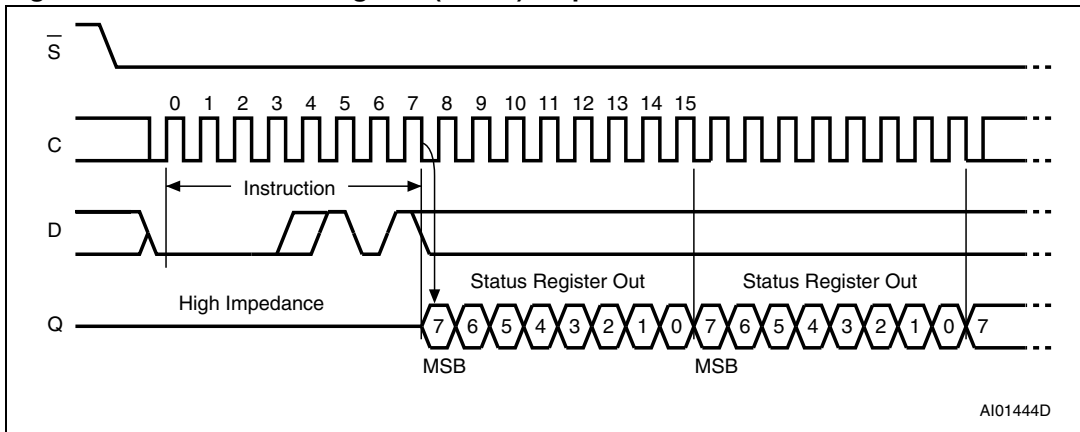

6.4 Write Status Register (WRSR)

The Write Status Register (WRSR) instruction allows new values to be written to the Status register. Before it can be accepted, a Write Enable (WREN) instruction must previously have been executed.

The Write Status Register (WRSR) instruction is entered by driving Chip Select (\bar{S}) low, sending the instruction code followed by the data byte on Serial Data input (D), and driving the Chip Select (\bar{S}) signal high. Chip Select (\bar{S}) must be driven high after the rising edge of Serial Clock (C) that latches in the eighth bit of the data byte, and before the next rising edge of Serial Clock (C). Otherwise, the Write Status Register (WRSR) instruction is not executed.

Driving the Chip Select (\bar{S}) signal high at a byte boundary of the input data triggers the self-timed write cycle that takes t_W to complete (as specified in [Table 13: DC characteristics \(M950x0, device grade 3\)](#) to [Table 20: AC characteristics \(M950x0-R, device grade 6\)](#)). The instruction sequence is shown in [Figure 10: Write Status Register \(WRSR\) sequence](#).

While the Write Status Register cycle is in progress, the Status register may still be read to check the value of the Write in progress (WIP) bit: the WIP bit is 1 during the self-timed write cycle t_W , and, 0 when the write cycle is complete. The WEL bit (Write enable latch) is also reset at the end of the write cycle t_W .

The Write Status Register (WRSR) instruction allows the user to change the values of the BP1, BP0 bits which define the size of the area that is to be treated as read only, as defined in [Table 3: Write-protected block size](#).

The contents of the BP1, BP0 bits are updated after the completion of the WRSR instruction, including the t_W write cycle.

The Write Status Register (WRSR) instruction has no effect on the b7, b6, b5, b4, b1 and b0 bits in the Status register. Bits b7, b6, b5, b4 are always read as 0.

Figure 10. Write Status Register (WRSR) sequence

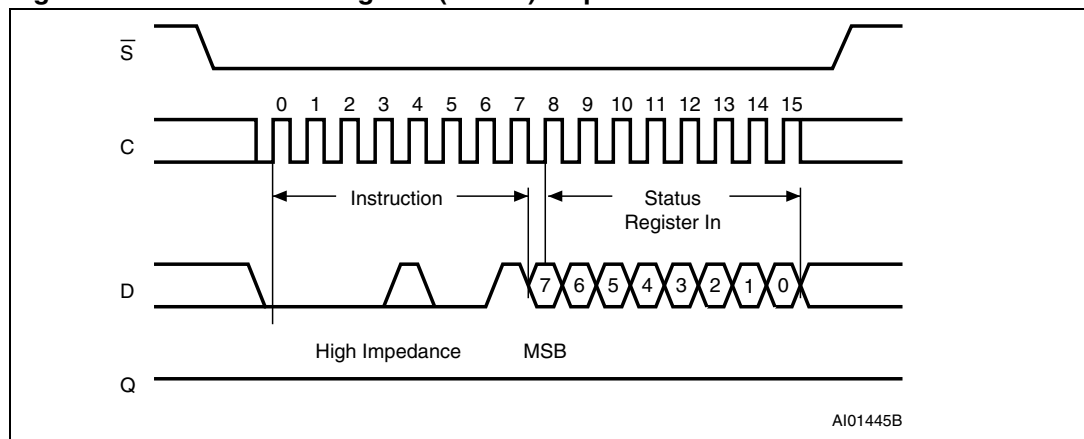

The instruction is not accepted, and is not executed, under the following conditions:

- if the Write Enable Latch (WEL) bit has not been set to 1 (by executing a Write Enable instruction just before)
- if a write cycle is already in progress
- if the device has not been deselected, by Chip Select (\overline{S}) being driven high, after the eighth bit, b0, of the data byte has been latched in
- if Write Protect (\overline{WP}) is low during the WRSR command (instruction, address and data)

6.5 Read from Memory Array (READ)

As shown in *Figure 11: Read from Memory Array (READ) sequence*, to send this instruction to the device, Chip Select (\bar{S}) is first driven low. The bits of the instruction byte and address byte are then shifted in, on Serial Data Input (D). For the M95040, the most significant address bit, A8, is incorporated as bit b3 of the instruction byte, as shown in *Table 4: Instruction set*. The address is loaded into an internal address register, and the byte of data at that address is shifted out, on Serial Data Output (Q).

If Chip Select (\bar{S}) continues to be driven low, an internal bit-pointer is automatically incremented at each clock cycle, and the corresponding data bit is shifted out.

When the highest address is reached, the address counter rolls over to zero, allowing the Read cycle to be continued indefinitely. The whole memory can, therefore, be read with a single READ instruction.

The Read cycle is terminated by driving Chip Select (\bar{S}) high. The rising edge of the Chip Select (\bar{S}) signal can occur at any time during the cycle.

The first byte addressed can be any byte within any page.

The instruction is not accepted, and is not executed, if a Write cycle is currently in progress.

Table 6. Address range bits

Device	M95040	M95020	M95010
Address Bits	A8-A0	A7-A0	A6-A0

Figure 11. Read from Memory Array (READ) sequence

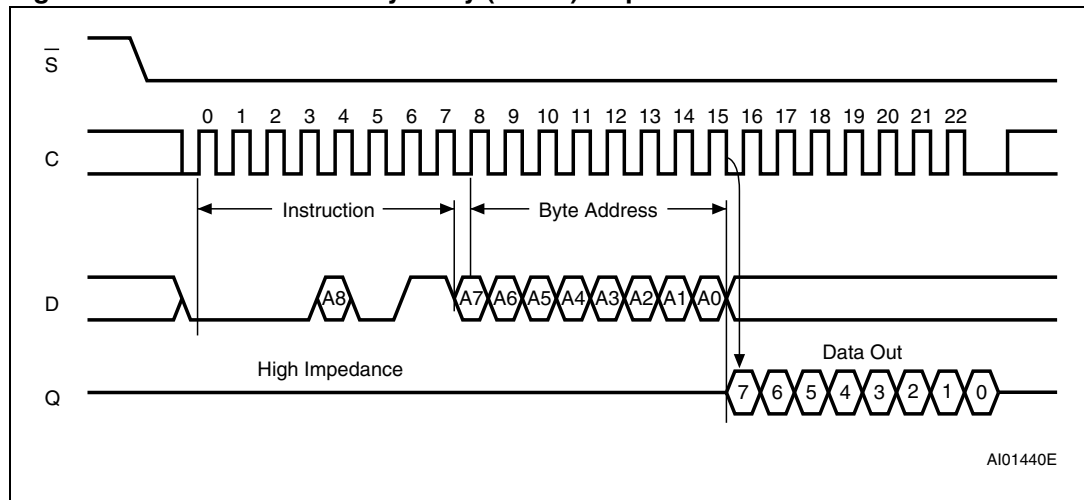

1. Depending on the memory size, as shown in *Table 6: Address range bits*, the most significant address bits are Don't Care.

6.6 Write to Memory Array (WRITE)

As shown in *Figure 12: Byte Write (WRITE) sequence*, to send this instruction to the device, Chip Select (\overline{S}) is first driven low. The bits of the instruction byte, address byte, and at least one data byte are then shifted in, on Serial Data input (D). The instruction is terminated by driving Chip Select (\overline{S}) high at a byte boundary of the input data. The self-timed Write cycle, triggered by the rising edge of Chip Select (\overline{S}), continues for a period t_W (as specified in *Table 13: DC characteristics (M950x0, device grade 3)* to *Table 20: AC characteristics (M950x0-R, device grade 6)*). After this time, the Write in Progress (WIP) bit is reset to 0.

In the case of *Figure 12: Byte Write (WRITE) sequence*, Chip Select (\overline{S}) is driven high after the eighth bit of the data byte has been latched in, indicating that the instruction is being used to write a single byte. If, though, Chip Select (\overline{S}) continues to be driven low, as shown in *Figure 13: Page Write (WRITE) sequence*, the next byte of input data is shifted in, so that more than a single byte, starting from the given address towards the end of the same page, can be written in a single internal Write cycle. If Chip Select (\overline{S}) still continues to be driven low, the next byte of input data is shifted in, and used to overwrite the byte at the start of the current page.

The instruction is not accepted, and is not executed, under the following conditions:

- if the Write Enable Latch (WEL) bit has not been set to 1 (by executing a Write Enable instruction just before)
- if a Write cycle is already in progress
- if the device has not been deselected, by Chip Select (\overline{S}) being driven high, at a byte boundary (after the rising edge of Serial Clock (C) that latches the last data bit, and before the next rising edge of Serial Clock (C) occurs anywhere on the bus)
- if Write Protect (\overline{WP}) is low or if the addressed page is in the area protected by the Block Protect (BP1 and BP0) bits

Note: The self-timed write cycle t_W is internally executed as a sequence of two consecutive events: [Erase addressed byte(s)], followed by [Program addressed byte(s)]. An erased bit is read as “0” and a programmed bit is read as “1”.

Figure 12. Byte Write (WRITE) sequence

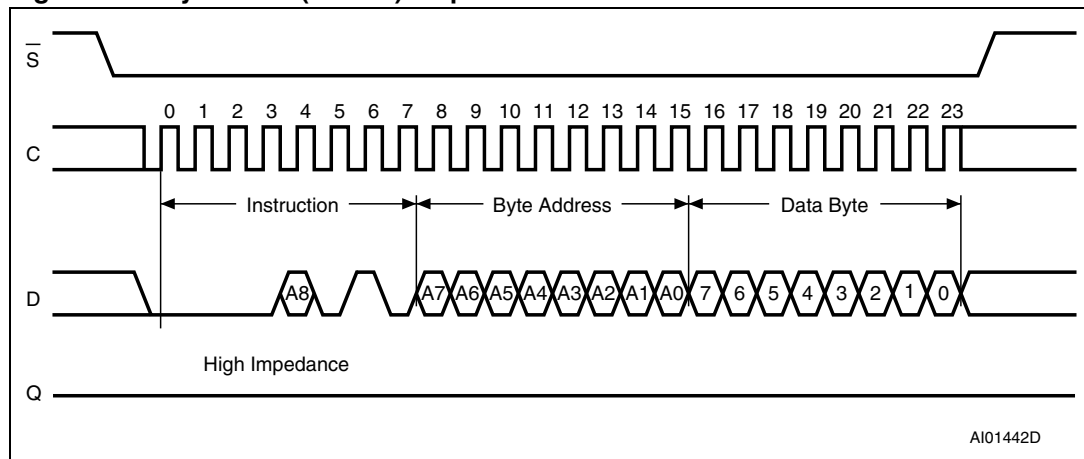

1. Depending on the memory size, as shown in *Table 6: Address range bits*, the most significant address bits are Don't Care.

Figure 13. Page Write (WRITE) sequence

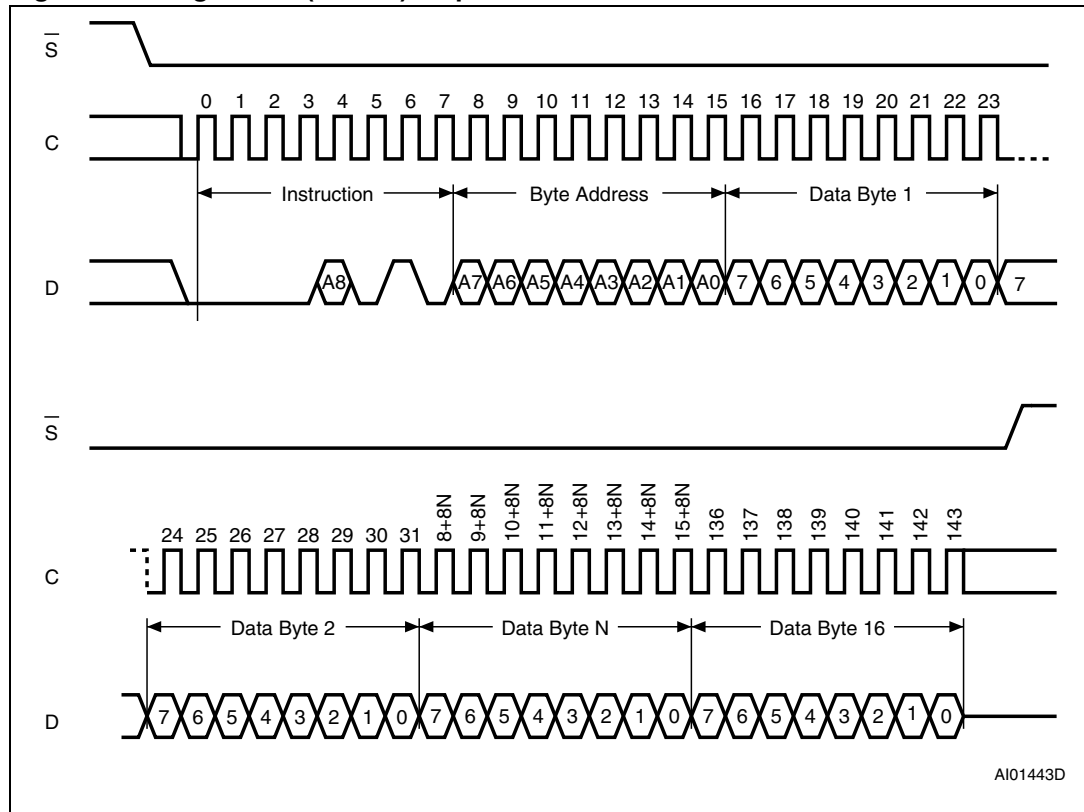

1. Depending on the memory size, as shown in [Table 6: Address range bits](#), the most significant address bits are Don't Care.

7 Power-up and delivery states

7.1 Power-up state

After Power-up, the device is in the following state:

- low power Standby Power mode
- deselected (after Power-up, a falling edge is required on Chip Select (\overline{S}) before any instructions can be started).
- not in the Hold Condition
- the Write Enable Latch (WEL) is reset to 0
- Write In Progress (WIP) is reset to 0

The BP1 and BP0 bits of the Status register are unchanged from the previous power-down (they are non-volatile bits).

7.2 Initial delivery state

The device is delivered with the memory array set at all 1s (FFh). The Block Protect (BP1 and BP0) bits are initialized to 0.

8 Maximum rating

Stressing the device outside the ratings listed in [Table 7: Absolute maximum ratings](#) may cause permanent damage to the device. These are stress ratings only, and operation of the device at these, or any other conditions outside those indicated in the operating sections of this specification, is not implied. Exposure to absolute maximum rating conditions for extended periods may affect device reliability. Refer also to the STMicroelectronics SURE Program and other relevant quality documents.

Table 7. Absolute maximum ratings

Symbol	Parameter	Min.	Max.	Unit
	Ambient operating temperature	-40	130	°C
T _{STG}	Storage temperature	-65	150	°C
T _{LEAD}	Lead temperature during soldering	see note ⁽¹⁾		°C
V _O	Output voltage	-0.50	V _{CC} +0.6	V
V _I	Input voltage	-0.50	V _{CC} +1.0	V
I _{OL}	DC output current (Q = 0)	-	5	mA
I _{IH}	DC output current (Q = 1)	-	5	mA
V _{CC}	Supply voltage	-0.50	6.5	V
V _{ESD}	Electrostatic pulse (Human Body Model) voltage ⁽²⁾	-	4000	V

1. Compliant with JEDEC Std J-STD-020C (for small body, Sn-Pb or Pb assembly), the ST ECOPACK® 7191395 specification, and the European directive on Restrictions on Hazardous Substances (RoHS) 2002/95/EU.
2. Positive and negative pulses applied on pin pairs, according to the AEC-Q100-002 (compliant with JEDEC Std JESD22-A114, C1=100pF, R1=1500Ω, R2=500Ω)

9 DC and AC parameters

This section summarizes the operating and measurement conditions, and the DC and AC characteristics of the device. The parameters in the DC and AC characteristic tables that follow are derived from tests performed under the measurement conditions summarized in the relevant tables. Designers should check that the operating conditions in their circuit match the measurement conditions when relying on the quoted parameters.

Table 8. Operating conditions (M950x0)

Symbol	Parameter	Min.	Max.	Unit
V_{CC}	Supply voltage	4.5	5.5	V
T_A	Ambient operating temperature (device grade 3)	-40	125	°C

Table 9. Operating conditions (M950x0-W)

Symbol	Parameter	Min.	Max.	Unit
V_{CC}	Supply voltage	2.5	5.5	V
T_A	Ambient operating temperature (device grade 6)	-40	85	°C
	Ambient operating temperature (device grade 3)	-40	125	°C

Table 10. Operating conditions (M950x0-R)

Symbol	Parameter	Min.	Max.	Unit
V_{CC}	Supply voltage	1.8	5.5	V
T_A	Ambient operating temperature	-40	85	°C

Table 11. AC test measurement conditions

Symbol	Parameter	Min.	Max.	Unit
C_L	Load capacitance	30		pF
	Input rise and fall times	-	50	ns
	Input pulse voltages	0.2 V_{CC} to 0.8 V_{CC}		V
	Input and output timing reference voltages	0.3 V_{CC} to 0.7 V_{CC}		V

1. Output Hi-Z is defined as the point where data out is no longer driven.

Figure 14. AC test measurement I/O waveform

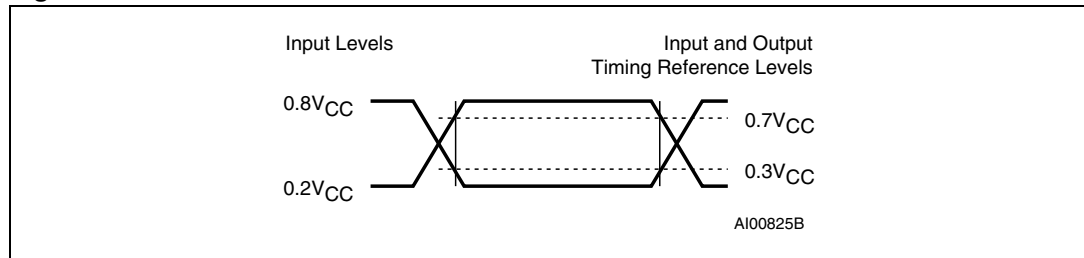

Table 12. Capacitance

Symbol	Parameter	Test condition	Min.	Max.	Unit
C_{OUT}	Output capacitance (Q)	$V_{OUT} = 0\text{ V}$	-	8	pF
C_{IN}	Input capacitance (D)	$V_{IN} = 0\text{ V}$	-	8	pF
	Input capacitance (other pins)	$V_{IN} = 0\text{ V}$	-	6	pF

1. Sampled only, not 100% tested, at $T_A=25^\circ\text{C}$ and a frequency of 5MHz.

Table 13. DC characteristics (M950x0, device grade 3)

Symbol	Parameter	Test condition	Min.	Max.	Unit
I_{LI}	Input leakage current	$V_{IN} = V_{SS}$ or V_{CC}	-	± 2	μA
I_{LO}	Output leakage current	$\bar{S} = V_{CC}$, $V_{OUT} = V_{SS}$ or V_{CC}	-	± 2	μA
I_{CC}	Supply current	$C = 0.1V_{CC}/0.9V_{CC}$ at 5 MHz, $V_{CC} = 5\text{ V}$, Q = open	-	3	mA
I_{CC1}	Supply current (Standby Power mode)	$\bar{S} = V_{CC}$, $V_{IN} = V_{SS}$ or V_{CC} $V_{CC} = 5\text{ V}$	-	5	μA
V_{IL}	Input low voltage		-0.45	$0.3 V_{CC}$	V
V_{IH}	Input high voltage		$0.7 V_{CC}$	$V_{CC}+1$	V
V_{OL}	Output low voltage	$I_{OL} = 2\text{ mA}$, $V_{CC} = 5\text{ V}$	-	0.4	V
V_{OH}	Output high voltage	$I_{OH} = -2\text{ mA}$, $V_{CC} = 5\text{ V}$	$0.8 V_{CC}$	-	V
$V_{RES}^{(1)}$	Internal reset threshold voltage		2.5	4.0	V

1. Characterized only, not 100% tested.

Table 14. DC characteristics (M950x0-W, device grade 6)

Symbol	Parameter	Test condition	Min.	Max.	Unit
I_{LI}	Input leakage current	$V_{IN} = V_{SS} \text{ or } V_{CC}$	-	± 2	μA
I_{LO}	Output leakage current	$\bar{S} = V_{CC}, V_{OUT} = V_{SS} \text{ or } V_{CC}$	-	± 2	μA
I_{CC}	Supply current	$C = 0.1V_{CC}/0.9V_{CC}$ at 5 MHz, $V_{CC} = 2.5 \text{ V}, Q = \text{open}$	-	2	mA
I_{CC1}	Supply current (Standby Power mode)	$\bar{S} = V_{CC}, V_{IN} = V_{SS} \text{ or } V_{CC}$ $V_{CC} = 2.5 \text{ V}$	-	1	μA
V_{IL}	Input low voltage		-0.45	$0.3 V_{CC}$	V
V_{IH}	Input high voltage		$0.7 V_{CC}$	$V_{CC}+1$	V
V_{OL}	Output low voltage	$I_{OL} = 1.5 \text{ mA}, V_{CC} = 2.5 \text{ V}$	-	0.4	V
V_{OH}	Output high voltage	$I_{OH} = -0.4 \text{ mA}, V_{CC} = 2.5 \text{ V}$	$0.8 V_{CC}$	-	V
$V_{RES}^{(1)}$	Internal reset threshold voltage		1.0	1.65	V

1. Characterized only, not 100% tested.

Table 15. DC characteristics (M950x0-W, device grade 3)

Symbol	Parameter	Test condition	Min.	Max.	Unit
I_{LI}	Input leakage current	$V_{IN} = V_{SS}$ or V_{CC}	-	± 2	μA
I_{LO}	Output leakage current	$\bar{S} = V_{CC}$, $V_{OUT} = V_{SS}$ or V_{CC}	-	± 2	μA
I_{CC}	Supply current	$C = 0.1V_{CC}/0.9V_{CC}$ at 5 MHz, $V_{CC} = 2.5 V$, Q = open	-	2	mA
I_{CC1}	Supply current (Standby Power mode)	$\bar{S} = V_{CC}$, $V_{IN} = V_{SS}$ or V_{CC} $V_{CC} = 2.5 V$	-	2	μA
V_{IL}	Input low voltage		-0.45	$0.3 V_{CC}$	V
V_{IH}	Input high voltage		$0.7 V_{CC}$	$V_{CC}+1$	V
V_{OL}	Output low voltage	$I_{OL} = 1.5 mA$, $V_{CC} = 2.5 V$	-	0.4	V
V_{OH}	Output high voltage	$I_{OH} = -0.4 mA$, $V_{CC} = 2.5 V$	$0.8 V_{CC}$	-	V
$V_{RES}^{(1)}$	Internal reset threshold voltage		1.0	1.65	V

1. Characterized only, not 100% tested.

Table 16. DC characteristics (M950x0-R, device grade 6)

Symbol	Parameter	Test condition	Min.	Max.	Unit
I_{LI}	Input leakage current	$V_{IN} = V_{SS}$ or V_{CC}	-	± 2	μA
I_{LO}	Output leakage current	$S = V_{CC}$, voltage applied on Q = V_{SS} or V_{CC}	-	± 2	μA
I_{CCR}	Supply current (Read)	$V_{CC} = 2.5 V$, $C = 0.1 V_{CC}$ or $0.9V_{CC}$, $f_C = 5 MHz$, Q = open	-	3	mA
		$V_{CC} = 1.8 V$, $C = 0.1V_{CC}$ or $0.9V_{CC}$ at max clock frequency, Q = open	-	2	mA
I_{CC1}	Supply current (Standby)	$V_{CC} = 5.0 V$, $\bar{S} = V_{CC}$, $V_{IN} = V_{SS}$ or V_{CC}	-	2	μA
		$V_{CC} = 2.5 V$, $\bar{S} = V_{CC}$, $V_{IN} = V_{SS}$ or V_{CC}	-	1	μA
		$V_{CC} = 1.8 V$, $\bar{S} = V_{CC}$, $V_{IN} = V_{SS}$ or V_{CC}	-	1	μA
V_{IL}	Input low voltage	$2.5 V < V_{CC} < 5.5 V$	-0.45	$0.3V_{CC}$	V
		$1.8 V < V_{CC} < 2.5 V$	-0.45	$0.25V_{CC}$	V
V_{IH}	Input high voltage	$2.5 V < V_{CC} < 5.5 V$	$0.7V_{CC}$	$V_{CC}+1$	V
		$1.8 V < V_{CC} < 2.5 V$	$0.75V_{CC}$	$V_{CC}+1$	V
V_{OL}	Output low voltage	$V_{CC} = 2.5 V$, $I_{OL} = 1.5 mA$, or $V_{CC} = 5.5 V$, $I_{OL} = 2 mA$	-	$0.2V_{CC}$	V
		$V_{CC} = 1.8 V$, $I_{OL} = 0.15 mA$	-	0.3	V
V_{OH}	Output high voltage	$V_{CC} = 2.5 V$, $I_{OH} = -0.4 mA$, or $V_{CC} = 5.5 V$, $I_{OH} = -2 mA$, or $V_{CC} = 1.8 V$, $I_{OH} = -0.1 mA$	$0.8V_{CC}$	-	V
$V_{RES}^{(1)}$	Internal reset threshold voltage		1.0	1.65	V

1. Characterized only, not 100% tested.

Table 17. AC characteristics (M950x0, device grade 3)

Test conditions specified in Table 11 and Table 8					
Symbol	Alt.	Parameter	Min.	Max.	Unit
f_C	f_{SCK}	Clock frequency	D.C.	5	MHz
t_{SLCH}	t_{CSS1}	\overline{S} active setup time	90	-	ns
t_{SHCH}	t_{CSS2}	\overline{S} not active setup time	90	-	ns
t_{SHSL}	t_{CS}	\overline{S} deselect time	100	-	ns
t_{CHSH}	t_{CSH}	\overline{S} active hold time	90	-	ns
t_{CHSL}		\overline{S} not active hold time	90	-	ns
$t_{CH}^{(1)}$	t_{CLH}	Clock high time	90	-	ns
$t_{CL}^{(1)}$	t_{CLL}	Clock low time	90	-	ns
$t_{CLCH}^{(2)}$	t_{RC}	Clock rise time		1	μ s
$t_{CHCL}^{(2)}$	t_{FC}	Clock fall time		1	μ s
t_{DVCH}	t_{DSU}	Data in setup time	20	-	ns
t_{CHDX}	t_{DH}	Data in hold time	30	-	ns
t_{HHCH}		Clock low hold time after \overline{HOLD} not active	70	-	ns
t_{HLCH}		Clock low hold time after \overline{HOLD} active	40	-	ns
t_{CLHL}		Clock low setup time before \overline{HOLD} active	0	-	ns
t_{CLHH}		Clock low setup time before \overline{HOLD} not active	0	-	ns
$t_{SHQZ}^{(2)}$	t_{DIS}	Output disable time	-	100	ns
t_{CLQV}	t_V	Clock low to output valid	-	60	ns
t_{CLQX}	t_{HO}	Output hold time	0	-	ns
$t_{QLQH}^{(2)}$	t_{RO}	Output rise time	-	50	ns
$t_{QHQL}^{(2)}$	t_{FO}	Output fall time	-	50	ns
t_{HHQV}	t_{LZ}	\overline{HOLD} high to output valid	-	50	ns
$t_{HLQZ}^{(2)}$	t_{HZ}	\overline{HOLD} low to output high-Z	-	100	ns
t_W	t_{WC}	Write time	-	5	ms

1. $t_{CH} + t_{CL}$ must never be less than the shortest possible clock period, $1 / f_C(\max)$

2. Value guaranteed by characterization, not 100% tested in production.

Table 18. AC characteristics (M950x0-W, device grade 6)

Test conditions specified in Table 11 and Table 9					
Symbol	Alt.	Parameter	Min.	Max.	Unit
f_C	f_{SCK}	Clock frequency	D.C.	10	MHz
t_{SLCH}	t_{CSS1}	\overline{S} active setup time	15	-	ns
t_{SHCH}	t_{CSS2}	\overline{S} not active setup time	15	-	ns
t_{SHSL}	t_{CS}	\overline{S} deselect time	40	-	ns
t_{CHSH}	t_{CSH}	\overline{S} active hold time	25	-	ns
t_{CHSL}		\overline{S} not active hold time	15	-	ns
$t_{CH}^{(1)}$	t_{CLH}	Clock high time	40	-	ns
$t_{CL}^{(1)}$	t_{CLL}	Clock low time	40	-	ns
$t_{CLCH}^{(2)}$	t_{RC}	Clock rise time	-	1	μ s
$t_{CHCL}^{(2)}$	t_{FC}	Clock fall time	-	1	μ s
t_{DVCH}	t_{DSU}	Data in setup time	15	-	ns
t_{CHDX}	t_{DH}	Data in hold time	15	-	ns
t_{HHCH}		Clock low hold time after \overline{HOLD} not active	15	-	ns
t_{HLCH}		Clock low hold time after \overline{HOLD} active	20	-	ns
t_{CLHL}		Clock low setup time before \overline{HOLD} active	0	-	ns
t_{CLHH}		Clock low setup time before \overline{HOLD} not active	0	-	ns
$t_{SHQZ}^{(2)}$	t_{DIS}	Output disable time	-	25	ns
t_{CLQV}	t_V	Clock low to output valid	-	35	ns
t_{CLQX}	t_{HO}	Output hold time	0	-	ns
$t_{QLQH}^{(2)}$	t_{RO}	Output rise time	-	20	ns
$t_{QHQL}^{(2)}$	t_{FO}	Output fall time	-	20	ns
t_{HHQV}	t_{LZ}	\overline{HOLD} high to output valid	-	25	ns
$t_{HLQZ}^{(2)}$	t_{HZ}	\overline{HOLD} low to output high-Z	-	35	ns
t_W	t_{WC}	Write time	-	5	ms

1. $t_{CH} + t_{CL}$ must never be less than the shortest possible clock period, $1 / f_C(\max)$

2. Value guaranteed by characterization, not 100% tested in production.

Table 19. AC characteristics (M950x0-W, device grade 3)

Test conditions specified in Table 11 and Table 9					
Symbol	Alt.	Parameter	Min.	Max.	Unit
f_C	f_{SCK}	Clock frequency	D.C.	5	MHz
t_{SLCH}	t_{CSS1}	\overline{S} active setup time	90	-	ns
t_{SHCH}	t_{CSS2}	\overline{S} not active setup time	90	-	ns
t_{SHSL}	t_{CS}	\overline{S} deselect time	100	-	ns
t_{CHSH}	t_{CSH}	\overline{S} active hold time	90	-	ns
t_{CHSL}		\overline{S} not active hold time	90	-	ns
$t_{CH}^{(1)}$	t_{CLH}	Clock high time	90	-	ns
$t_{CL}^{(1)}$	t_{CLL}	Clock low time	90	-	ns
$t_{CLCH}^{(2)}$	t_{RC}	Clock rise time	-	1	μ s
$t_{CHCL}^{(2)}$	t_{FC}	Clock fall time	-	1	μ s
t_{DVCH}	t_{DSU}	Data in setup time	20	-	ns
t_{CHDX}	t_{DH}	Data in hold time	30	-	ns
t_{HHCH}		Clock low hold time after \overline{HOLD} not active	70	-	ns
t_{HLCH}		Clock low hold time after \overline{HOLD} active	40	-	ns
t_{CLHL}		Clock low setup time before \overline{HOLD} active	0	-	ns
t_{CLHH}		Clock low setup time before \overline{HOLD} not active	0	-	ns
$t_{SHQZ}^{(2)}$	t_{DIS}	Output disable time	-	100	ns
t_{CLQV}	t_V	Clock low to output valid	-	60	ns
t_{CLQX}	t_{HO}	Output hold time	0	-	ns
$t_{QLQH}^{(2)}$	t_{RO}	Output rise time	-	50	ns
$t_{QHQL}^{(2)}$	t_{FO}	Output fall time	-	50	ns
t_{HHQV}	t_{LZ}	\overline{HOLD} high to output valid	-	50	ns
$t_{HLQZ}^{(2)}$	t_{HZ}	\overline{HOLD} low to output high-Z	-	100	ns
t_W	t_{WC}	Write time	-	5	ms

- $t_{CH} + t_{CL}$ must never be less than the shortest possible clock period, $1 / f_C(\max)$
- Value guaranteed by characterization, not 100% tested in production.

Table 20. AC characteristics (M950x0-R, device grade 6)

Test conditions specified in Table 11 and Table 10 ⁽¹⁾					
Symbol	Alt.	Parameter	Min.	Max.	Unit
f_C	f_{SCK}	Clock frequency	D.C.	5	MHz
t_{SLCH}	t_{CSS1}	\overline{S} active setup time	90	-	ns
t_{SHCH}	t_{CSS2}	\overline{S} not active setup time	90	-	ns
t_{SHSL}	t_{CS}	\overline{S} deselect time	100	-	ns
t_{CHSH}	t_{CSH}	\overline{S} active hold time	90	-	ns
t_{CHSL}		\overline{S} not active hold time	90	-	ns
$t_{CH}^{(2)}$	t_{CLH}	Clock high time	90	-	ns
$t_{CL}^{(1)}$	t_{CLL}	Clock low time	90	-	ns
$t_{CLCH}^{(3)}$	t_{RC}	Clock rise time	-	1	μ s
$t_{CHCL}^{(2)}$	t_{FC}	Clock fall time	-	1	μ s
t_{DVCH}	t_{DSU}	Data in setup time	20	-	ns
t_{CHDX}	t_{DH}	Data in hold time	30	-	ns
t_{HHCH}		Clock low hold time after \overline{HOLD} not active	70	-	ns
t_{HLCH}		Clock low hold time after \overline{HOLD} active	40	-	ns
t_{CLHL}		Clock low setup time before \overline{HOLD} active	0	-	ns
t_{CLHH}		Clock low setup time before \overline{HOLD} not active	0	-	ns
$t_{SHQZ}^{(2)}$	t_{DIS}	Output disable time	-	100	ns
t_{CLQV}	t_V	Clock low to output valid	-	80	ns
t_{CLQX}	t_{HO}	Output hold time	0	-	ns
$t_{QLQH}^{(2)}$	t_{RO}	Output rise time	-	50	ns
$t_{QHQL}^{(2)}$	t_{FO}	Output fall time	-	50	ns
t_{HHQV}	t_{LZ}	\overline{HOLD} high to output valid	-	50	ns
$t_{HLQZ}^{(2)}$	t_{HZ}	\overline{HOLD} low to output high-Z	-	100	ns
t_W	t_{WC}	Write time	-	5	ms

1. The test flow guarantees the AC parameter values defined in this table (when $V_{CC} = 1.8$ V) and the AC parameter values defined in [Table 18: AC characteristics \(M950x0-W, device grade 6\)](#) (when $V_{CC} = 2.5$ or when $V_{CC} = 5.0$ V).
2. $t_{CH} + t_{CL}$ must never be less than the shortest possible clock period, $1 / f_C(\max)$
3. Value guaranteed by characterization, not 100% tested in production.

Figure 15. Serial input timing

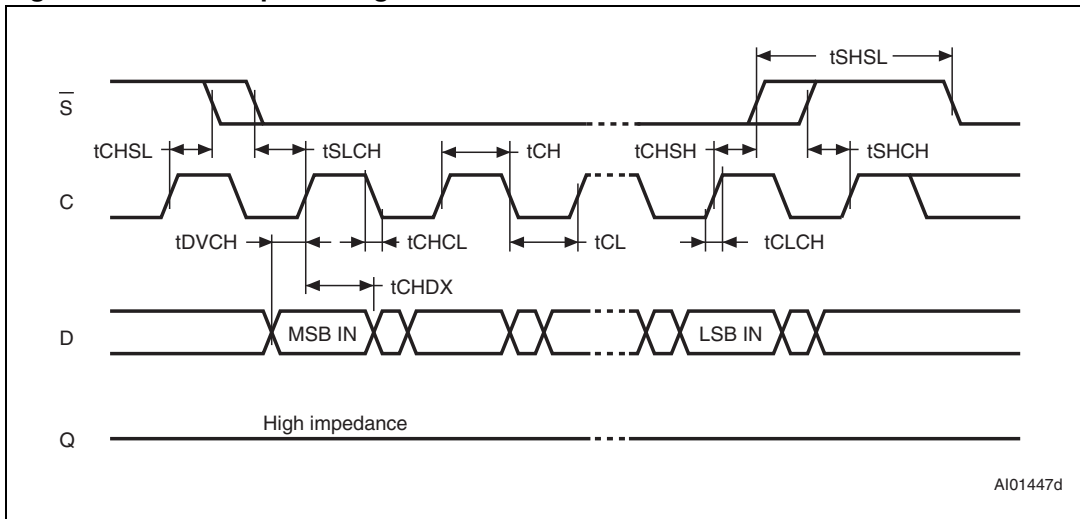

AI01447d

Figure 16. Hold timing

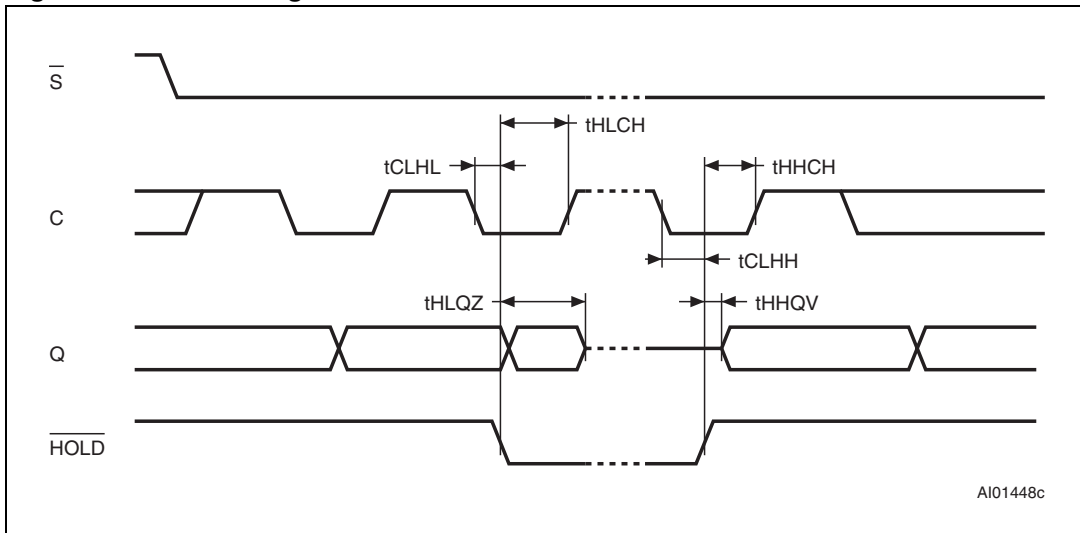

AI01448c

Figure 17. Serial output timing

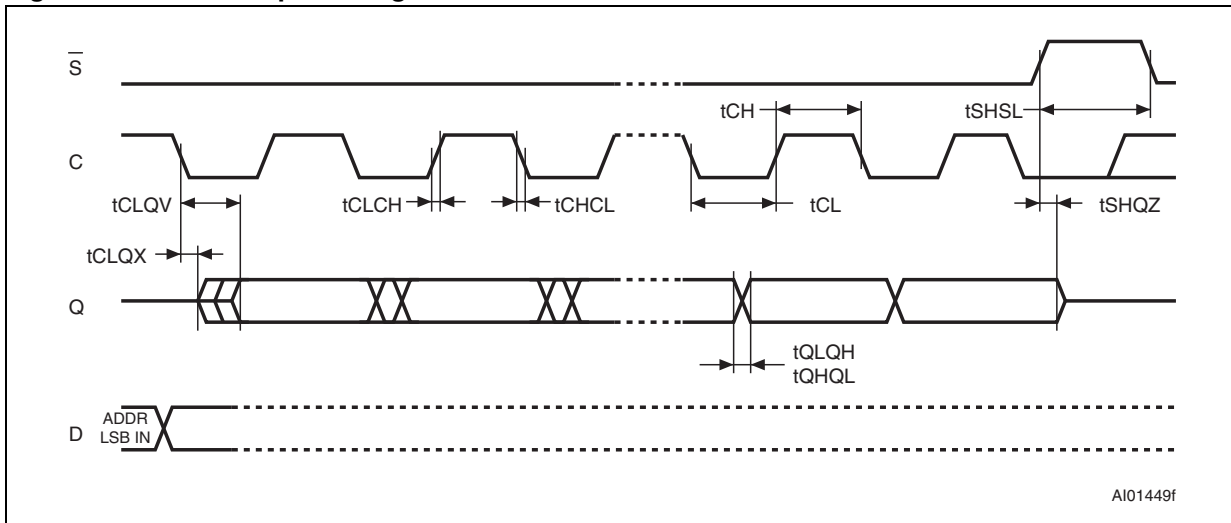

10 Package mechanical data

In order to meet environmental requirements, ST offers the device in different grades of ECOPACK® packages, depending on their level of environmental compliance. ECOPACK® specifications, grade definitions and product status are available at: www.st.com. ECOPACK® is an ST trademark.

Figure 18. SO8N — 8-lead plastic small outline 150 mils body width, package outline

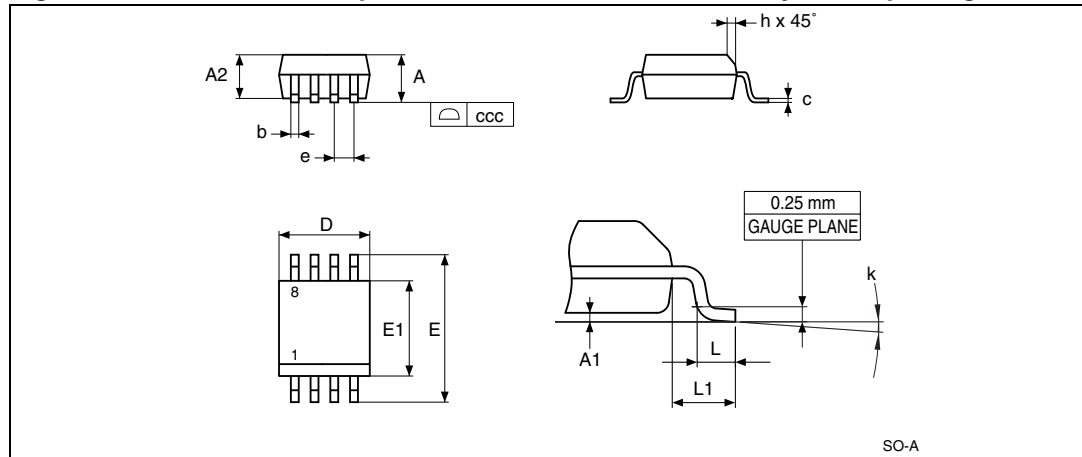

1. Drawing is not to scale.

Table 21. SO8N — 8-lead plastic small outline, 150 mils body width, package mechanical data

Symbol	millimeters			inches ⁽¹⁾		
	Typ	Min	Max	Typ	Min	Max
A	-	-	1.75	-	-	0.0689
A1	-	0.1	0.25	-	0.0039	0.0098
A2	-	1.25	-	-	0.0492	-
b	-	0.28	0.48	-	0.011	0.0189
c	-	0.17	0.23	-	0.0067	0.0091
ccc	-	-	0.1	-	-	0.0039
D	4.9	4.8	5	0.1929	0.189	0.1969
E	6	5.8	6.2	0.2362	0.2283	0.2441
E1	3.9	3.8	4	0.1535	0.1496	0.1575
e	1.27	-	-	0.05	-	-
h	-	0.25	0.5	-	0.0098	0.0197
k	-	0°	8°	-	0°	8°
L	-	0.4	1.27	-	0.0157	0.05
L1	1.04	-	-	0.0409	-	-

1. Values in inches are converted from mm and rounded to 4 decimal digits.

Figure 19. TSSOP8 — 8-lead thin shrink small outline, package outline

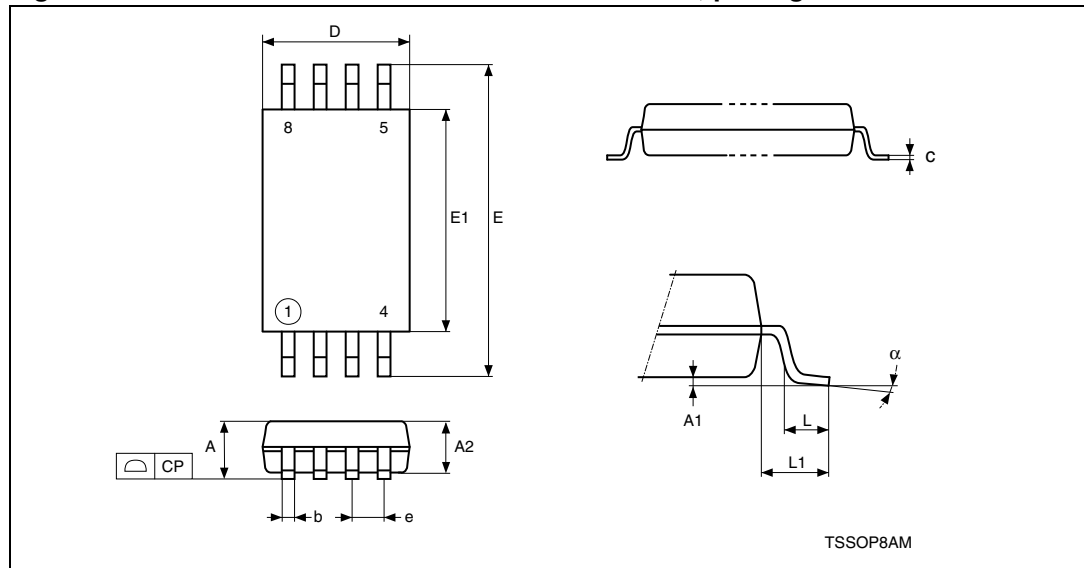

1. Drawing is not to scale.

Table 22. TSSOP8 — 8-lead thin shrink small outline, package mechanical data

Symbol	millimeters			inches ⁽¹⁾		
	Typ	Min	Max	Typ	Min	Max
A	-	-	1.2	-	-	0.0472
A1	-	0.05	0.15	-	0.002	0.0059
A2	1	0.8	1.05	0.0394	0.0315	0.0413
b	-	0.19	0.3	-	0.0075	0.0118
c	-	0.09	0.2	-	0.0035	0.0079
CP	-	-	0.1	-	-	0.0039
D	3	2.9	3.1	0.1181	0.1142	0.122
e	0.65	-	-	0.0256	-	-
E	6.4	6.2	6.6	0.252	0.2441	0.2598
E1	4.4	4.3	4.5	0.1732	0.1693	0.1772
L	0.6	0.45	0.75	0.0236	0.0177	0.0295
L1	1	-	-	0.0394	-	-
α	-	0°	8°	-	0°	8°
N (number of leads)	8			8		

1. Values in inches are converted from mm and rounded to 4 decimal digits.

Figure 20. UFDFPN8 (MLP8) 8-lead ultra thin fine pitch dual flat package no lead 2 × 3mm, outline

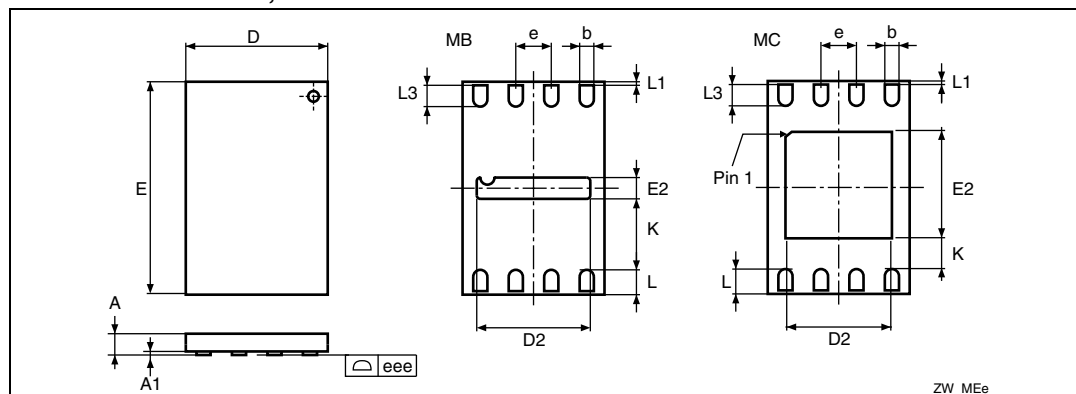

1. Drawing is not to scale.
2. The central pad (the area E2 by D2 in the above illustration) is pulled, internally, to V_{SS} . It must not be allowed to be connected to any other voltage or signal line on the PCB, for example during the soldering process.
3. The circle in the top view of the package indicates the position of pin 1.

Table 23. UFDFPN8 (MLP8) 8-lead ultra thin fine pitch dual flat package no lead 2 × 3mm, data

Symbol	millimeters			inches ⁽¹⁾		
	Typ	Min	Max	Typ	Min	Max
A	0.550	0.450	0.600	0.0217	0.0177	0.0236
A1	0.020	0.000	0.050	0.0008	0.0000	0.0020
b	0.250	0.200	0.300	0.0098	0.0079	0.0118
D	2.000	1.900	2.100	0.0787	0.0748	0.0827
D2 (rev MB)	1.600	1.500	1.700	0.0630	0.0591	0.0669
D2 (rev MC)	-	1.200	1.600	-	0.0472	0.0630
E	3.000	2.900	3.100	0.1181	0.1142	0.1220
E2 (rev MB)	0.200	0.100	0.300	0.0079	0.0039	0.0118
E2 (rev MC)	-	1.200	1.600	-	0.0472	0.0630
e	0.500	-	-	0.0197	-	-
K (rev MB)	-	0.800	-	-	0.0315	-
K (rev MC)	-	0.300	-	-	0.0118	-
L (rev MB)	0.450	0.400	0.500	0.0177	0.0157	0.0197
L (rev MC)	-	0.300	0.500	-	0.0118	0.0197
L1	-	-	0.150	-	-	0.0059
L3	-	0.300	-	-	0.0118	-
eee ⁽²⁾	0.080			0.0031		

1. Values in inches are converted from mm and rounded to 4 decimal digits.
2. Applied for exposed die paddle and terminals. Exclude embedding part of exposed die paddle from measuring.

11 Part numbering

Table 24. Ordering information scheme

Example:	M95040	-	W	MN	6	T	P /G
Device type M95 = SPI serial access EEPROM							
Device function 040 = 4 Kbit (512 x 8) 020 = 2 Kbit (256 x 8) 010 = 1 Kbit (128 x 8)							
Operating voltage blank = V _{CC} = 4.5 to 5.5V W = V _{CC} = 2.5 to 5.5V R = V _{CC} = 1.8 to 5.5V							
Package MN = SO8 (150 mil width) DW = TSSOP8 (169 mil width) MB or MC = UDFPN8 (MLP8) 2 x 3mm							
Device grade 6 = Industrial temperature range, -40 to 85 °C. Device tested with standard test flow 3 = Device tested with high reliability certified flow ⁽¹⁾ . Automotive temperature range (-40 to 125 °C)							
Option blank = Standard packing T = Tape and reel packing							
Plating technology P or G = ECOPACK [®] (RoHS compliant)							
Process⁽²⁾ /G or /S = F6SP36%							

1. ST strongly recommends the use of the Automotive Grade devices for use in an automotive environment. The high reliability certified flow (HRCF) is described in the quality note QNEE9801. Please ask your nearest ST sales office for a copy.
2. Used only for device grade 3

For a list of available options (speed, package, etc.) or for further information on any aspect of this device, please contact your nearest ST sales office.

12 Revision history

Table 25. Document revision history

Date	Version	Changes
10-May-2000	2.2	s/issuing three bytes/issuing two bytes/ in the 2nd sentence of the Byte Write Operation
16-Mar-2001	2.3	Human Body Model meets JEDEC std (Table 2). Minor adjustments to Figs 7,9,10,11 & Tab 9. Wording changes, according to the standard glossary Illustrations and Package Mechanical data updated
19-Jul-2001	2.4	Temperature range '3' added to the -W supply voltage range in DC and AC characteristics
11-Oct-2001	3.0	Document reformatted using the new template
26-Feb-2002	3.1	Description of chip deselect after 8th clock pulse made more explicit
27-Sep-2002	3.2	Position of A8 in Read Instruction Sequence Figure corrected. Load Capacitance C_L changed
24-Oct-2002	3.3	Minimum values for t_{CHHL} and t_{CHHH} changed.
24-Feb-2003	3.4	Description of Read from Memory Array (READ) instruction corrected, and clarified
28-May-2003	3.5	New products, identified by the process letter W, added
25-Jun-2003	3.6	Correction to current products, identified by the process letter K not L. I_{CC} changed in DC characteristics, and t_{CHHL} , t_{CHHH} substituted in AC characteristics Voltage range -S upgraded by removing it, and adding the -R voltage range in its place Temperature range 5 removed.
21-Nov-2003	4.0	Table of contents, and Pb-free options added. $V_{IL}(\min)$ improved to -0.45V
02-Feb-2004	4.1	$V_{IL}(\max)$ and $t_{CLQV}(\max)$ changed
01-Mar-2004	5.0	Absolute Maximum Ratings for $V_{IO}(\min)$ and $V_{CC}(\min)$ improved. Soldering temperature information clarified for RoHS compliant devices. New 5V and 2.5V devices, with process letter W, promoted from preliminary data to full data. Device Grade 3 clarified, with reference to HRCF and automotive environments
05-Oct-2004	6.0	Product List summary table added. Process identification letter "G" information added. Order information for Tape and Reel changed to T. AEC-Q100-002 compliance. Device Grade information clarified. t_{HHQX} corrected to t_{HHQV} . Signal Description updated. 10MHz, 5ms Write is now the present product. $t_{CH}+t_{CL}<1/f_C$ constraint clarified

Table 25. Document revision history

Date	Version	Changes
06-Nov-2006	7	<p>Document converted to new template, Table 5: Status register format moved to below Section 6.3: Read Status Register (RDSR).</p> <p>PDIP package removed. UDFPN8 (MB) package added (see Figure 20 and Table 23) and SO8N package specifications updated (see Figure 18 and Table 21). Packages are ECOPACK® compliant.</p> <p>Section 6.7: Cycling added. Section 2.8: Supply voltage (VCC) added and information removed below Section 4: Operating features.</p> <p>Figure 3: Bus master and memory devices on the SPI bus modified.</p> <p>T_{LEAD} parameter modified, Note 1 changed, and T_A added to Table 7: Absolute maximum ratings.</p> <p>Characteristics of previous product identified by process letter K removed. CL modified in Table 11: AC test measurement conditions. Note removed below Table 13 and Table 13.</p> <p>Information in Table 16 is no longer Preliminary data, I_{CC}, I_{CC1} and V_{IL} modified. End timing line of t_{SHQZ} moved in Figure 17.</p> <p>t_{CHHL} and t_{CHHH} changed to t_{CLHL} and t_{CLHH}, respectively in Figure 16, Table 18, Table 17, Table 18, Table 19 and Table 20.</p> <p>Plating technology and Process updated in Table 24: Ordering information scheme.</p>
20-Mar-2008	8	<p>Section 2.8: Supply voltage (VCC) updated.</p> <p>Section 3: Connecting to the SPI bus modified.</p> <p>Section 6.6: Write to Memory Array (WRITE) modified.</p> <p>Device grade 6 removed in the 4.5 to 5.5 V V_{CC} range (see Table 8).</p> <p>Table 16: DC characteristics (M950x0-R, device grade 6) modified.</p> <p>Table 18: AC characteristics (M950x0-W, device grade 6) modified: frequency changed from 5 MHz to 10 MHz.</p> <p>Table 20: AC characteristics (M950x0-R, device grade 6) modified: frequency changed from 2 MHz to 5 MHz.</p> <p>Section 10: Package mechanical data:</p> <ul style="list-style-type: none"> – Inches are calculated from millimeters and rounded to the third decimal digit. – UDFPN8 package specifications modified. <p>Blank option removed below Plating technology in Table 24: Ordering information scheme. Table 25, Table 26 and Table 27 added.</p>

Table 25. Document revision history

Date	Version	Changes
24-Sep-2009	9	<p><i>Section 2.8: Supply voltage (VCC)</i> and <i>Section 6.4: Write Status Register (WRSR)</i> updated.</p> <p><i>Section 6.6: Write to Memory Array (WRITE)</i> clarified.</p> <p>I_{OL} and I_{OH} added to <i>Table 7: Absolute maximum ratings</i>.</p> <p>V_{RES} added to DC characteristics tables <i>13, 14, 15</i> and <i>16</i>. t_{CLQV} modified in <i>Figure 20: AC characteristics (M950x0-R, device grade 6)</i>.</p> <p>Note added to <i>Table 20: AC characteristics (M950x0-R, device grade 6)</i>.</p> <p><i>Figure 15: Serial input timing, Figure 16: Hold timing</i> and <i>Figure 17: Serial output timing</i> updated.</p> <p>Note added below <i>Figure 20: UFDFPN8 (MLP8) 8-lead ultra thin fine pitch dual flat package no lead 2 × 3mm, outline</i>.</p> <p>/W process option removed from <i>Table 24: Ordering information scheme</i>.</p> <p>ECOPACK text updated. Small text changes.</p>
02-Feb-2012	10	<p>Document renamed from “M95040 M95020 M95010” to “M950x0 M950x0-W M950x0-R”</p> <p>Silhouette of UFDFPN8 (MB or MC) on the cover page updated.</p> <p><i>Section 6.3: Read Status Register (RDSR)</i> updated.</p> <p>Text modified in <i>Section 6.3.1: WIP bit</i>.</p> <p><i>Table 7: Absolute maximum ratings</i> updated.</p> <p><i>Figure 20: UFDFPN8 (MLP8) 8-lead ultra thin fine pitch dual flat package no lead 2 × 3mm, outline</i> modified.</p> <p><i>Table 23: UFDFPN8 (MLP8) 8-lead ultra thin fine pitch dual flat package no lead 2 × 3mm, data</i> updated.</p> <p>Removed tables of available products from <i>Section 11: Part numbering</i>.</p>

Please Read Carefully:

Information in this document is provided solely in connection with ST products. STMicroelectronics NV and its subsidiaries ("ST") reserve the right to make changes, corrections, modifications or improvements, to this document, and the products and services described herein at any time, without notice.

All ST products are sold pursuant to ST's terms and conditions of sale.

Purchasers are solely responsible for the choice, selection and use of the ST products and services described herein, and ST assumes no liability whatsoever relating to the choice, selection or use of the ST products and services described herein.

No license, express or implied, by estoppel or otherwise, to any intellectual property rights is granted under this document. If any part of this document refers to any third party products or services it shall not be deemed a license grant by ST for the use of such third party products or services, or any intellectual property contained therein or considered as a warranty covering the use in any manner whatsoever of such third party products or services or any intellectual property contained therein.

UNLESS OTHERWISE SET FORTH IN ST'S TERMS AND CONDITIONS OF SALE ST DISCLAIMS ANY EXPRESS OR IMPLIED WARRANTY WITH RESPECT TO THE USE AND/OR SALE OF ST PRODUCTS INCLUDING WITHOUT LIMITATION IMPLIED WARRANTIES OF MERCHANTABILITY, FITNESS FOR A PARTICULAR PURPOSE (AND THEIR EQUIVALENTS UNDER THE LAWS OF ANY JURISDICTION), OR INFRINGEMENT OF ANY PATENT, COPYRIGHT OR OTHER INTELLECTUAL PROPERTY RIGHT.

UNLESS EXPRESSLY APPROVED IN WRITING BY TWO AUTHORIZED ST REPRESENTATIVES, ST PRODUCTS ARE NOT RECOMMENDED, AUTHORIZED OR WARRANTED FOR USE IN MILITARY, AIR CRAFT, SPACE, LIFE SAVING, OR LIFE SUSTAINING APPLICATIONS, NOR IN PRODUCTS OR SYSTEMS WHERE FAILURE OR MALFUNCTION MAY RESULT IN PERSONAL INJURY, DEATH, OR SEVERE PROPERTY OR ENVIRONMENTAL DAMAGE. ST PRODUCTS WHICH ARE NOT SPECIFIED AS "AUTOMOTIVE GRADE" MAY ONLY BE USED IN AUTOMOTIVE APPLICATIONS AT USER'S OWN RISK.

Resale of ST products with provisions different from the statements and/or technical features set forth in this document shall immediately void any warranty granted by ST for the ST product or service described herein and shall not create or extend in any manner whatsoever, any liability of ST.

ST and the ST logo are trademarks or registered trademarks of ST in various countries.

Information in this document supersedes and replaces all information previously supplied.

The ST logo is a registered trademark of STMicroelectronics. All other names are the property of their respective owners.

© 2012 STMicroelectronics - All rights reserved

STMicroelectronics group of companies

Australia - Belgium - Brazil - Canada - China - Czech Republic - Finland - France - Germany - Hong Kong - India - Israel - Italy - Japan - Malaysia - Malta - Morocco - Philippines - Singapore - Spain - Sweden - Switzerland - United Kingdom - United States of America

www.st.com