



M24C16-x M24C08-x M24C04-x M24C02-x M24C01-x

16 Kbit, 8 Kbit, 4 Kbit, 2 Kbit and 1 Kbit serial I²C bus EEPROM

Features

- Supports both the 100 kHz I²C Standard-mode and the 400 kHz I²C Fast-mode
- Single supply voltage:
 - 2.5 V to 5.5 V for M24Cxx-W
 - 1.8 V to 5.5 V for M24Cxx
 - 1.7 V to 5.5 V for M24Cxx-F
- Write Control input
- Byte and Page Write (up to 16 bytes)
- Random and Sequential Read modes
- Self-timed programming cycle
- Automatic address incrementing
- Enhanced ESD/latch-up protection
- More than 1 million write cycles
- More than 40-year data retention
- Packages:
 - SO8, TSSOP8, UDFPN8: ECOPACK2[®] (RoHS-compliant and Halogen-free)
 - PDIP8: ECOPACK1[®] (RoHS-compliant)

Table 1. Device summary

Reference	Part number
M24C16-x	M24C16-W
	M24C16-R
	M24C16-F
M24C08-x	M24C08-W
	M24C08-R
	M24C08-F
M24C04-x	M24C04-W
	M24C04-R
	M24C04-F
M24C02-x	M24C02-W
	M24C02-R
M24C01-x	M24C01-W
	M24C01-R

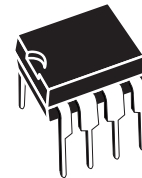

PDIP8 (BN)



SO8 (MN)
150 mils width



TSSOP8 (DW)
169 mils width

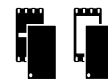

UDFPN8 (MB, MC)
2 x 3 mm (MLP)



WLCSP (CS)⁽¹⁾
Thin WLCSP (CT)⁽²⁾

1. Only M24C08-F and M24C16-F devices are offered in the WLCSP package.
2. Only M24C08-F devices are offered in the Thin WLCSP package.

Contents

1	Description	6
2	Signal description	8
2.1	Serial Clock (SCL)	8
2.2	Serial Data (SDA)	8
2.3	Chip Enable (E0, E1, E2)	8
2.3.1	Write Control (WC)	8
2.4	Supply voltage (V_{CC})	9
2.4.1	Operating supply voltage V_{CC}	9
2.4.2	Power-up conditions	9
2.4.3	Device reset	9
2.4.4	Power-down conditions	9
3	Device operation	11
3.1	Start condition	11
3.2	Stop condition	11
3.3	Acknowledge bit (ACK)	11
3.4	Data input	11
3.5	Memory addressing	12
3.6	Write operations	13
3.6.1	Byte Write	14
3.6.2	Page Write	14
3.6.3	Minimizing system delays by polling on ACK	16
3.7	Read operations	17
3.7.1	Random Address Read	17
3.7.2	Current Address Read	18
3.7.3	Sequential Read	18
3.7.4	Acknowledge in Read mode	18
4	Initial delivery state	19
5	Maximum rating	19
6	DC and AC parameters	20

7	Package mechanical data	27
8	Part numbering	33
9	Revision history	34

List of tables

Table 1.	Device summary	1
Table 2.	Signal names	6
Table 3.	Device select code	10
Table 4.	Operating modes	12
Table 5.	Absolute maximum ratings	19
Table 6.	Operating conditions (M24Cxx-W)	20
Table 7.	Operating conditions (M24Cxx-R)	20
Table 8.	Operating conditions (M24Cxx-F)	20
Table 9.	DC characteristics (M24Cxx-W, device grade 6)	21
Table 10.	DC characteristics (M24Cxx-W, device grade 3)	21
Table 11.	DC characteristics (M24Cxx-R)	22
Table 12.	DC characteristics (M24Cxx-F)	23
Table 13.	AC measurement conditions.	23
Table 14.	Input parameters.	23
Table 15.	AC characteristics at 400 kHz (I^2C Fast-mode) (M24Cxx-W, M24Cxx-R, M24Cxx-F)	24
Table 16.	AC characteristics at 100 kHz (I^2C Standard-mode) (M24Cxx-W, M24Cxx-R, M24Cxx-F)	25
Table 17.	M24C08: WLCSP (0.5 mm height) 0.4 mm pitch, 5 bumps, package data	27
Table 18.	M24C08: Thin WLCSP (0.3 mm height), 0.4 mm pitch, 5 bumps, package data	28
Table 19.	M24C16: WLCSP (0.5 mm height) 0.4 mm pitch, 5 bumps, package data	28
Table 20.	SO8 narrow – 8 lead plastic small outline, 150 mils body width, package mechanical data	29
Table 21.	UFDFPN8 (MLP8) 8-lead ultra thin fine pitch dual flat package no lead 2 x 3 mm, data	30
Table 22.	TSSOP8 – 8 lead thin shrink small outline, package mechanical data	31
Table 23.	PDIP8 – 8 pin plastic DIP, 0.25 mm lead frame, package mechanical data	32
Table 24.	Ordering information scheme	33
Table 25.	Document revision history	34

List of figures

Figure 1.	Logic diagram	6
Figure 2.	8-pin package connections (top view)	7
Figure 3.	WLCSP and thin WLCSP connections (top view, marking side, with balls on the underside)	7
Figure 4.	Device select code	8
Figure 5.	Maximum R_P value versus bus parasitic capacitance (C) for an I ² C bus	9
Figure 6.	I ² C bus protocol	10
Figure 7.	Write mode sequences with $\overline{WC} = 1$ (data write inhibited)	13
Figure 8.	Write mode sequences with $\overline{WC} = 0$ (data write enabled)	15
Figure 9.	Write cycle polling flowchart using ACK	16
Figure 10.	Read mode sequences	17
Figure 11.	AC measurement I/O waveform	23
Figure 12.	AC waveforms	26
Figure 13.	WLCSP (0.5 mm) and Thin WLCSP (0.3 mm) 0.4 mm pitch 5 bumps, package outline	27
Figure 14.	SO8 narrow – 8 lead plastic small outline, 150 mils body width, package outline	29
Figure 15.	UFDFPN8 (MLP8) 8-lead ultra thin fine pitch dual flat package no lead 2 x 3 mm, outline	30
Figure 16.	TSSOP8 – 8 lead thin shrink small outline, package outline	31
Figure 17.	PDIP8 – 8 pin plastic DIP, 0.25 mm lead frame, package outline	32

1 Description

These I²C-compatible electrically erasable programmable memory (EEPROM) devices are organized as 2048/1024/512/256/128 x 8 (M24C16, M24C08, M24C04, M24C02 and M24C01).

Figure 1. Logic diagram

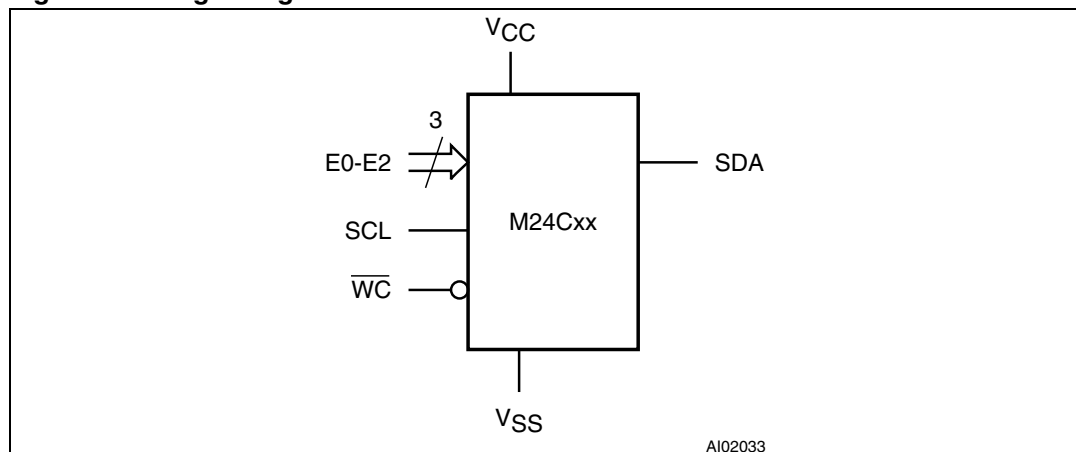

I²C uses a two-wire serial interface, comprising a bidirectional data line and a clock line. The devices carry a built-in 4-bit Device Type Identifier code (1010) in accordance with the I²C bus definition.

The device behaves as a slave in the I²C protocol, with all memory operations synchronized by the serial clock. Read and Write operations are initiated by a Start condition, generated by the bus master. The Start condition is followed by a device select code and Read/Write bit (\overline{RW}) (as described in [Table 3](#)), terminated by an acknowledge bit.

When writing data to the memory, the device inserts an acknowledge bit during the 9th bit time, following the bus master's 8-bit transmission. When data is read by the bus master, the bus master acknowledges the receipt of the data byte in the same way. Data transfers are terminated by a Stop condition after an Ack for Write, and after a NoAck for Read.

Table 2. Signal names

Signal name	Function	Direction
E0, E1, E2	Chip Enable	Input
SDA	Serial Data	Input/output
SCL	Serial Clock	Input
\overline{WC}	Write Control	Input
V _{CC}	Supply voltage	
V _{SS}	Ground	

Figure 2. 8-pin package connections (top view)

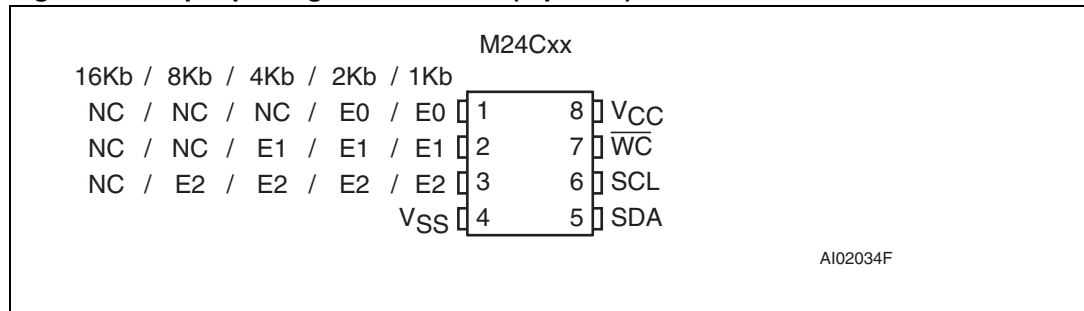

1. NC = Not connected
2. See [Section 7: Package mechanical data](#) for package dimensions, and how to identify pin-1.
3. The Ei inputs are not decoded, and are therefore decoded as "0" (See [Section 2.3: Chip Enable \(E0, E1, E2\)](#) for more information).

Figure 3. WLCSP and thin WLCSP connections (top view, marking side, with balls on the underside)

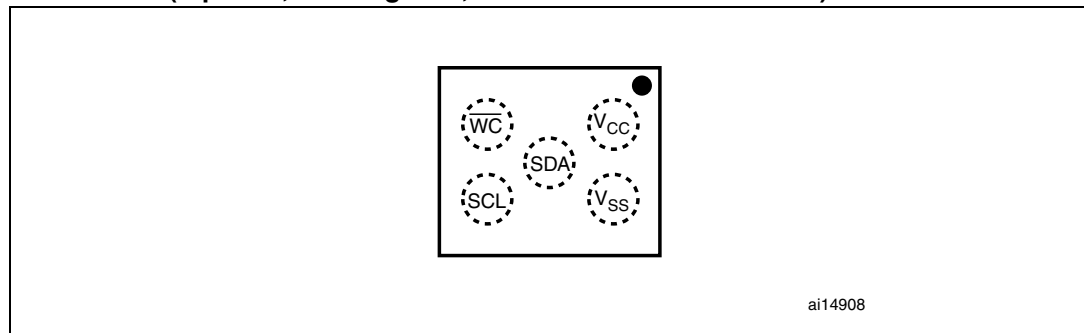

1. For devices of less than 16Kb (see [Figure 2: 8-pin package connections \(top view\)](#)), the Ei inputs are not connected to a ball, therefore the Ei input is decoded as "0" (see also [Section 2.3: Chip Enable \(E0, E1, E2\)](#))

Caution: EEPROM dice delivered in wafer form or in WLCSP package by STMicroelectronics must never be exposed to ultra violet (UV) light, since EEPROM cells loose their charge (and so their binary value) when exposed to UV light.

2 Signal description

2.1 Serial Clock (SCL)

This input signal is used to strobe all data in and out of the device. In applications where this signal is used by slave devices to synchronize the bus to a slower clock, the bus master must have an open drain output, and a pull-up resistor can be connected from Serial Clock (SCL) to V_{CC} . ([Figure 5](#) indicates how the value of the pull-up resistor can be calculated). In most applications, though, this method of synchronization is not employed, and so the pull-up resistor is not necessary, provided that the bus master has a push-pull (rather than open drain) output.

2.2 Serial Data (SDA)

This bidirectional signal is used to transfer data in or out of the device. It is an open drain output that may be wire-ORed with other open drain or open collector signals on the bus. A pull up resistor must be connected from Serial Data (SDA) to V_{CC} . ([Figure 5](#) indicates how the value of the pull-up resistor can be calculated).

2.3 Chip Enable (E0, E1, E2)

These input signals are used to set the value that is to be looked for on the least significant bits of the 7-bit device select code. These inputs must be tied to V_{CC} or V_{SS} , to establish the device select code as shown in [Figure 4](#). When not connected (left floating), E_i inputs are read as low (0).

Figure 4. Device select code

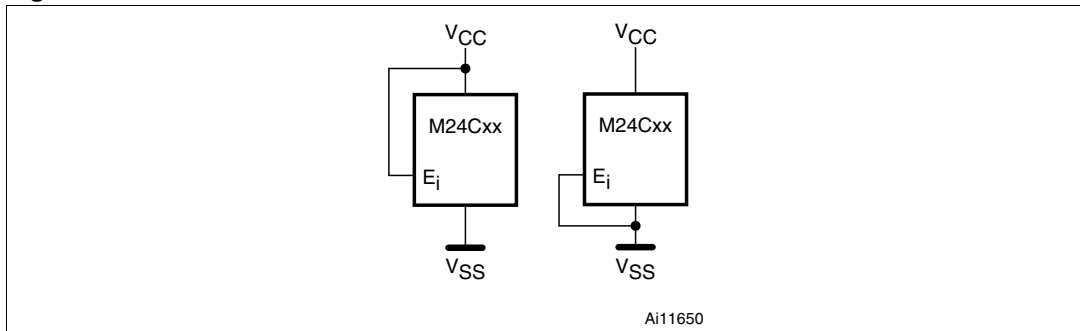

2.3.1 Write Control (\overline{WC})

This input signal is useful for protecting the entire contents of the memory from inadvertent write operations. Write operations are disabled to the entire memory array when Write Control (\overline{WC}) is driven High. When unconnected, the signal is internally read as V_{IL} , and Write operations are allowed.

When Write Control (\overline{WC}) is driven High, device select and address bytes are acknowledged, data bytes are not acknowledged.

2.4 Supply voltage (V_{CC})

2.4.1 Operating supply voltage V_{CC}

Prior to selecting the memory and issuing instructions to it, a valid and stable V_{CC} voltage within the specified [$V_{CC}(\min)$, $V_{CC}(\max)$] range must be applied (see [Table 6](#), [Table 7](#) and [Table 8](#)). In order to secure a stable DC supply voltage, it is recommended to decouple the V_{CC} line with a suitable capacitor (usually of the order of 10 nF to 100 nF) close to the V_{CC}/V_{SS} package pins.

This voltage must remain stable and valid until the end of the transmission of the instruction and, for a Write instruction, until the completion of the internal write cycle (t_W).

2.4.2 Power-up conditions

The V_{CC} voltage has to rise continuously from 0 V up to the minimum V_{CC} operating voltage defined in [Table 6](#), [Table 7](#) and [Table 8](#) and the rise time must *not* vary faster than 1 V/ μ s.

2.4.3 Device reset

In order to prevent inadvertent write operations during power-up, a power-on-reset (POR) circuit is included. At power-up (continuous rise of V_{CC}), the device does not respond to any instruction until V_{CC} reaches the power-on-reset threshold voltage (this threshold is lower than the minimum V_{CC} operating voltage defined in [Table 6](#), [Table 7](#) and [Table 8](#)). When V_{CC} passes over the POR threshold, the device is reset and enters the Standby Power mode. The device, however, must not be accessed until V_{CC} reaches a valid and stable V_{CC} voltage within the specified [$V_{CC}(\min)$, $V_{CC}(\max)$] range.

In a similar way, during power-down (continuous decrease in V_{CC}), as soon as V_{CC} drops below the power-on-reset threshold voltage, the device stops responding to any instruction sent to it.

2.4.4 Power-down conditions

During power-down (continuous decrease in V_{CC}), the device must be in the Standby Power mode (mode reached after decoding a Stop condition, assuming that there is no internal write cycle in progress).

Figure 5. Maximum R_p value versus bus parasitic capacitance (C) for an I²C bus

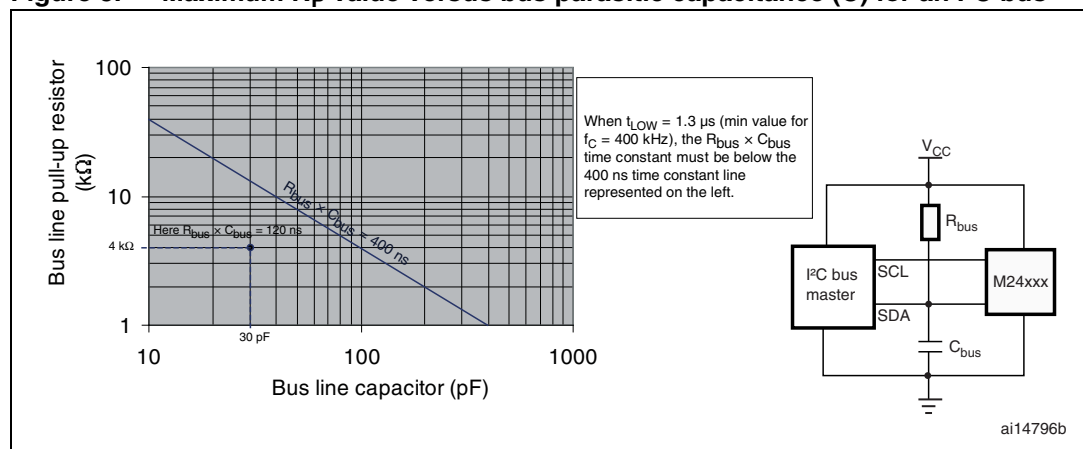

Figure 6. I²C bus protocol

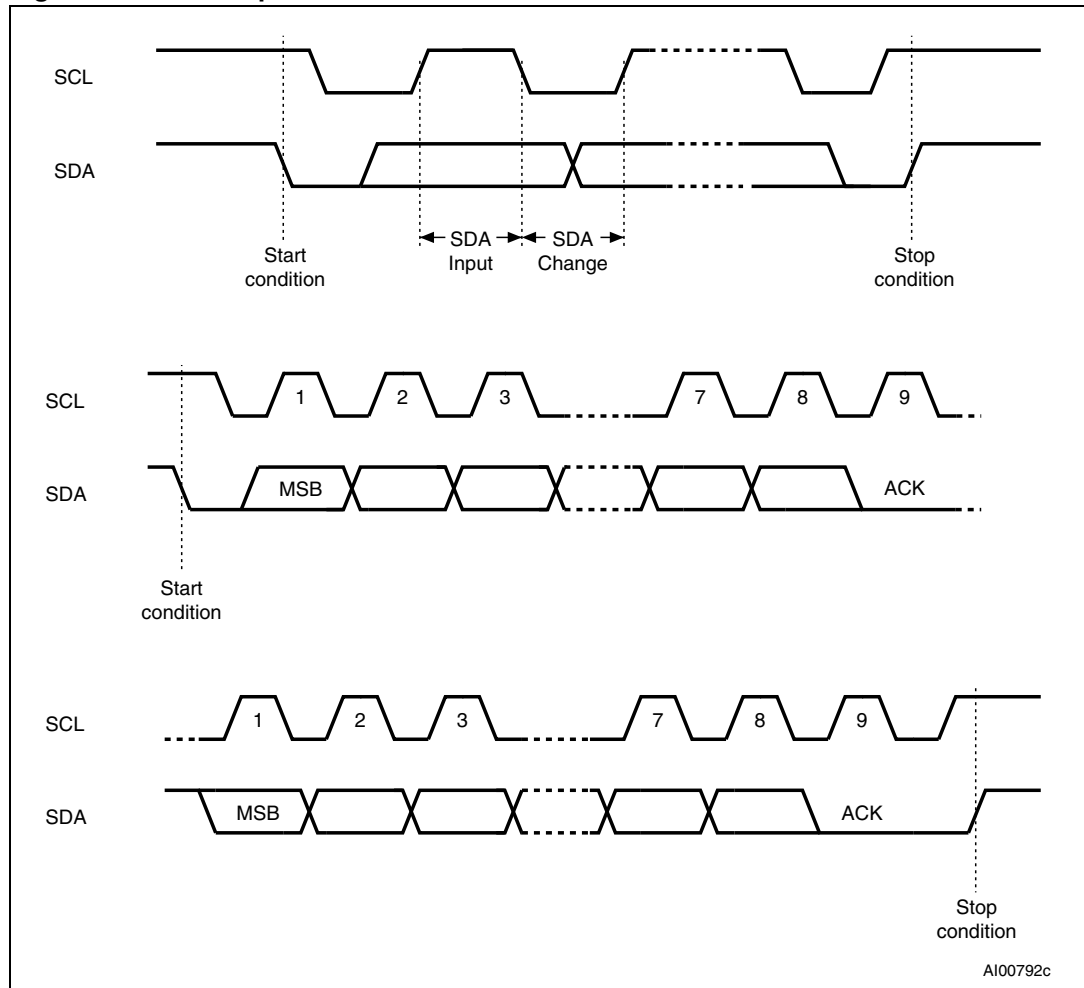

Table 3. Device select code

	Device type identifier ⁽¹⁾				Chip Enable ^{(2),(3)}			R \bar{W}
	b7	b6	b5	b4	b3	b2	b1	b0
M24C01 select code	1	0	1	0	E2	E1	E0	R \bar{W}
M24C02 select code	1	0	1	0	E2	E1	E0	R \bar{W}
M24C04 select code	1	0	1	0	E2	E1	A8	R \bar{W}
M24C08 select code	1	0	1	0	E2	A9	A8	R \bar{W}
M24C16 select code	1	0	1	0	A10	A9	A8	R \bar{W}

1. The most significant bit, b7, is sent first.
2. E0, E1 and E2 are compared against the respective external pins on the memory device.
3. A10, A9 and A8 represent most significant bits of the address.

3 Device operation

The device supports the I²C protocol. This is summarized in [Figure 6](#). Any device that sends data on to the bus is defined to be a transmitter, and any device that reads the data to be a receiver. The device that controls the data transfer is known as the bus master, and the other as the slave device. A data transfer can only be initiated by the bus master, which will also provide the serial clock for synchronization. The device is always a slave in all communication.

3.1 Start condition

Start is identified by a falling edge of Serial Data (SDA) while Serial Clock (SCL) is stable in the High state. A Start condition must precede any data transfer command. The device continuously monitors (except during a Write cycle) Serial Data (SDA) and Serial Clock (SCL) for a Start condition.

3.2 Stop condition

Stop is identified by a rising edge of Serial Data (SDA) while Serial Clock (SCL) is stable and driven High. A Stop condition terminates communication between the device and the bus master. A Read command that is followed by NoAck can be followed by a Stop condition to force the device into the Standby mode. A Stop condition at the end of a Write command triggers the internal Write cycle.

3.3 Acknowledge bit (ACK)

The acknowledge bit is used to indicate a successful byte transfer. The bus transmitter, whether it be bus master or slave device, releases Serial Data (SDA) after sending eight bits of data. During the 9th clock pulse period, the receiver pulls Serial Data (SDA) Low to acknowledge the receipt of the eight data bits.

3.4 Data input

During data input, the device samples Serial Data (SDA) on the rising edge of Serial Clock (SCL). For correct device operation, Serial Data (SDA) must be stable during the rising edge of Serial Clock (SCL), and the Serial Data (SDA) signal must change *only* when Serial Clock (SCL) is driven Low.

3.5 Memory addressing

To start communication between the bus master and the slave device, the bus master must initiate a Start condition. Following this, the bus master sends the device select code, shown in [Table 3](#) (on Serial Data (SDA), most significant bit first).

The device select code consists of a 4-bit Device Type Identifier, and a 3-bit Chip Enable “Address” (E2, E1, E0). To address the memory array, the 4-bit Device Type Identifier is 1010b.

Each device is given a unique 3-bit code on the Chip Enable (E0, E1, E2) inputs. When the device select code is received, the device only responds if the Chip Enable Address is the same as the value on the Chip Enable (E0, E1, E2) inputs. However, those devices with larger memory capacities (the M24C16, M24C08 and M24C04) need more address bits. E0 is not available for use on devices that need to use address line A8; E1 is not available for devices that need to use address line A9, and E2 is not available for devices that need to use address line A10 (see [Figure 2](#) and [Table 3](#) for details). Using the E0, E1 and E2 inputs, up to eight M24C02 (or M24C01), four M24C04, two M24C08 or one M24C16 devices can be connected to one I²C bus. In each case, and in the hybrid cases, this gives a total memory capacity of 16 Kbits, 2 KBytes (except where M24C01 devices are used).

The 8th bit is the Read/Write bit (\overline{RW}). This bit is set to 1 for Read and 0 for Write operations.

If a match occurs on the device select code, the corresponding device gives an acknowledgment on Serial Data (SDA) during the 9th bit time. If the device does not match the device select code, it deselects itself from the bus, and goes into Standby mode.

Table 4. Operating modes

Mode	\overline{RW} bit	$\overline{WC}^{(1)}$	Bytes	Initial sequence
Current Address Read	1	X	1	Start, Device Select, $\overline{RW} = 1$
Random Address Read	0	X	1	Start, Device Select, $\overline{RW} = 0$, Address
	1	X		reStart, Device Select, $\overline{RW} = 1$
Sequential Read	1	X	≥ 1	Similar to Current or Random Address Read
Byte Write	0	V_{IL}	1	Start, Device Select, $\overline{RW} = 0$
Page Write	0	V_{IL}	≤ 16	Start, Device Select, $\overline{RW} = 0$

1. X = V_{IH} or V_{IL} .

Figure 7. Write mode sequences with $\overline{WC} = 1$ (data write inhibited)

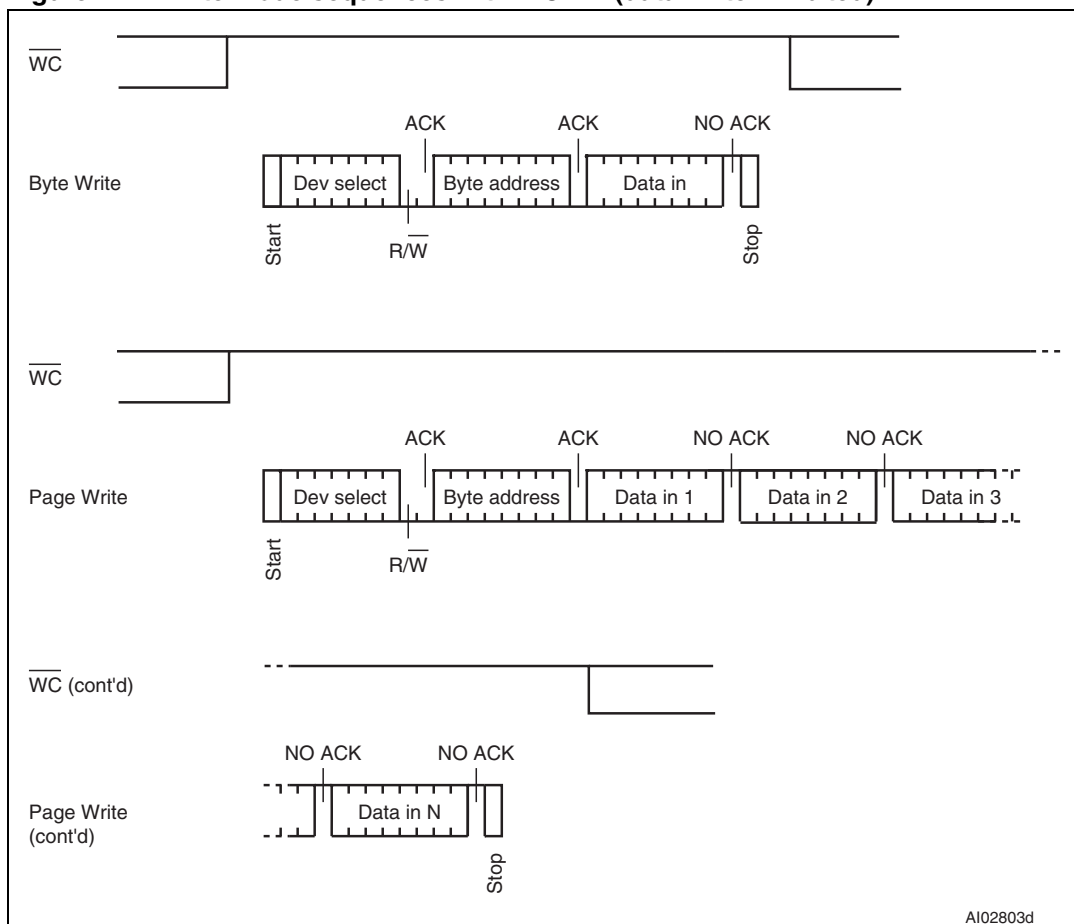

3.6 Write operations

Following a Start condition the bus master sends a device select code with the Read/Write bit ($\overline{R/W}$) reset to 0. The device acknowledges this, as shown in [Figure 8](#), and waits for an address byte. The device responds to the address byte with an acknowledge bit, and then waits for the data byte.

When the bus master generates a Stop condition immediately after a data byte Ack bit (in the “10th bit” time slot), either at the end of a Byte Write or a Page Write, the internal write cycle is triggered. A Stop condition at any other time slot does not trigger the internal write cycle.

After the Stop condition, the t_w delay, and the successful completion of a Write operation, the device internal address counter is automatically incremented, to point to the next byte address after the last one that was modified. During the internal Write cycle, Serial Data (SDA) is disabled internally, and the device does not respond to any request.

If the Write Control (\overline{WC}) input is driven High, the Write instruction is not executed and the corresponding data bytes are not acknowledged as shown in [Figure 7](#).

3.6.1 Byte Write

After the device select code and the address byte, the bus master sends one data byte. If the addressed location is Write-protected, by Write Control (\overline{WC}) being driven High, the device replies to the data byte with NoAck, as shown in [Figure 7](#), and the location is not modified. If, instead, the addressed location is not Write-protected, the device replies with Ack. The bus master terminates the transfer by generating a Stop condition, as shown in [Figure 8](#).

3.6.2 Page Write

The Page Write mode allows up to 16 bytes to be written in a single Write cycle, provided that they are all located in the same page in the memory: that is, the most significant memory address bits are the same. If more bytes are sent than will fit up to the end of the page, a condition known as 'roll-over' occurs. This should be avoided, as data starts to become overwritten in an implementation dependent way.

The bus master sends from 1 to 16 bytes of data, each of which is acknowledged by the device if Write Control (\overline{WC}) is Low. If the addressed location is Write-protected, by Write Control (\overline{WC}) being driven High, the device replies to the data bytes with NoAck, as shown in [Figure 7](#), and the locations are not modified. After each byte is transferred, the internal byte address counter (the 4 least significant address bits only) is incremented. The transfer is terminated by the bus master generating a Stop condition.

Figure 8. Write mode sequences with $\overline{WC} = 0$ (data write enabled)

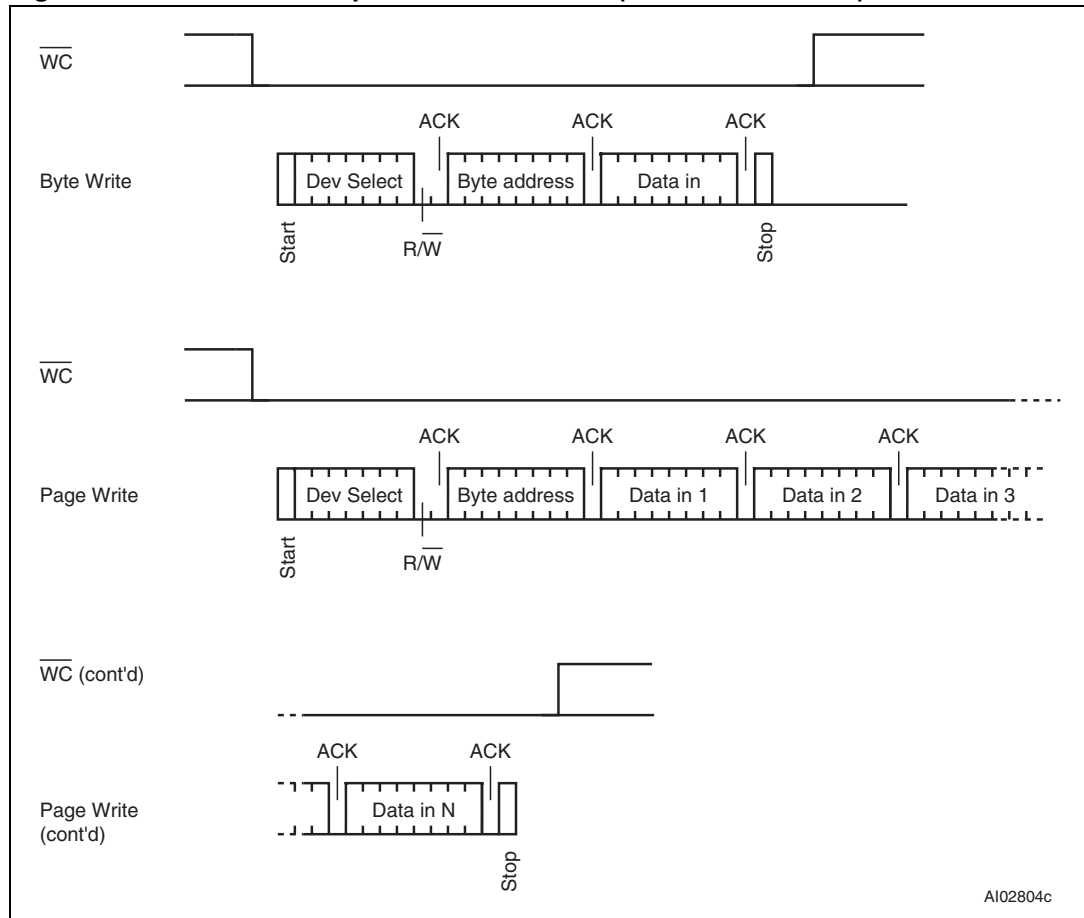
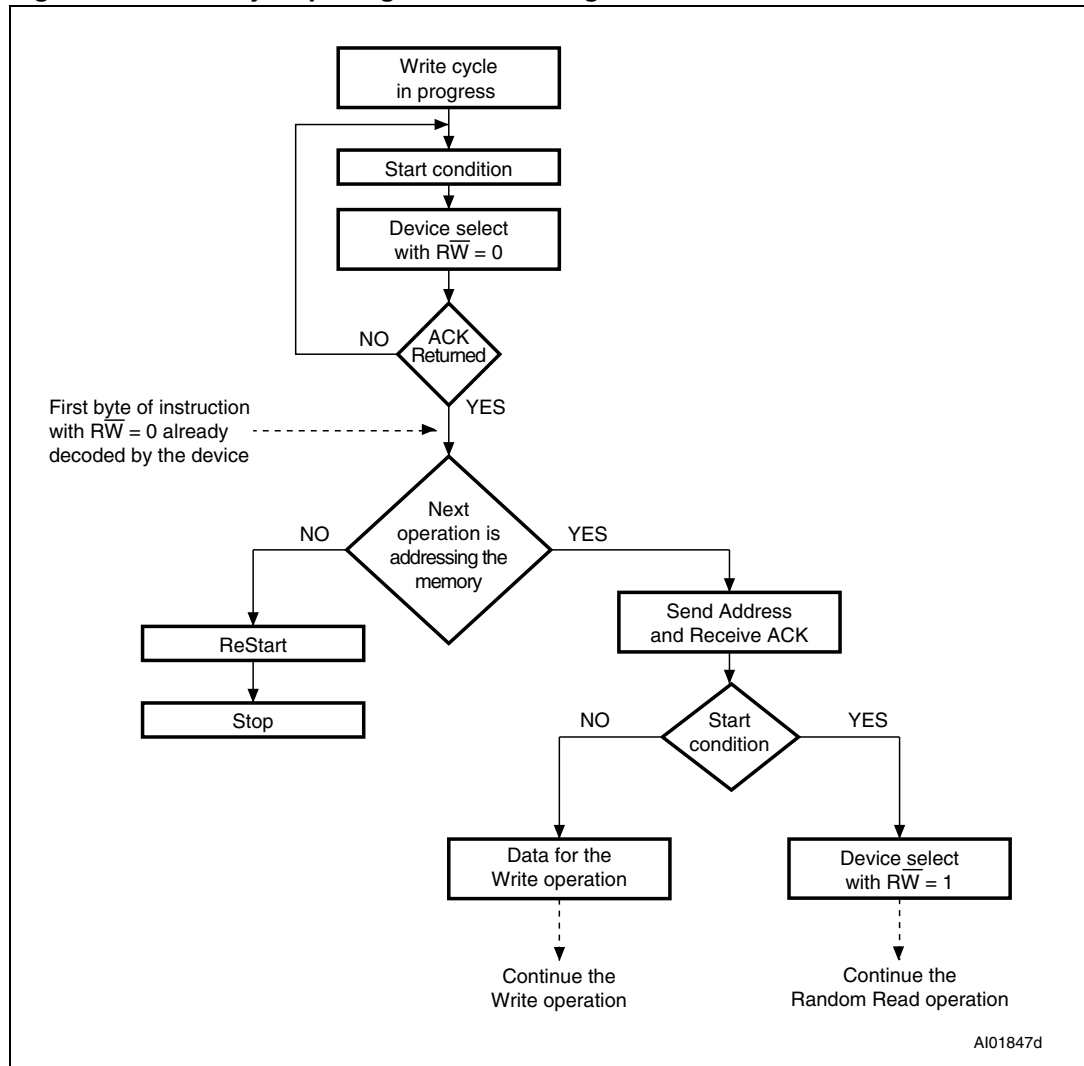

Figure 9. Write cycle polling flowchart using ACK



3.6.3 Minimizing system delays by polling on ACK

During the internal Write cycle, the device disconnects itself from the bus, and writes a copy of the data from its internal latches to the memory cells. The maximum Write time (t_w) is shown in [Table 15](#), but the typical time is shorter. To make use of this, a polling sequence can be used by the bus master.

The sequence, as shown in [Figure 9](#), is:

- Initial condition: a Write cycle is in progress.
- Step 1: the bus master issues a Start condition followed by a device select code (the first byte of the new instruction).
- Step 2: if the device is busy with the internal Write cycle, no Ack will be returned and the bus master goes back to Step 1. If the device has terminated the internal Write cycle, it responds with an Ack, indicating that the device is ready to receive the second part of the instruction (the first byte of this instruction having been sent during Step 1).

Figure 10. Read mode sequences

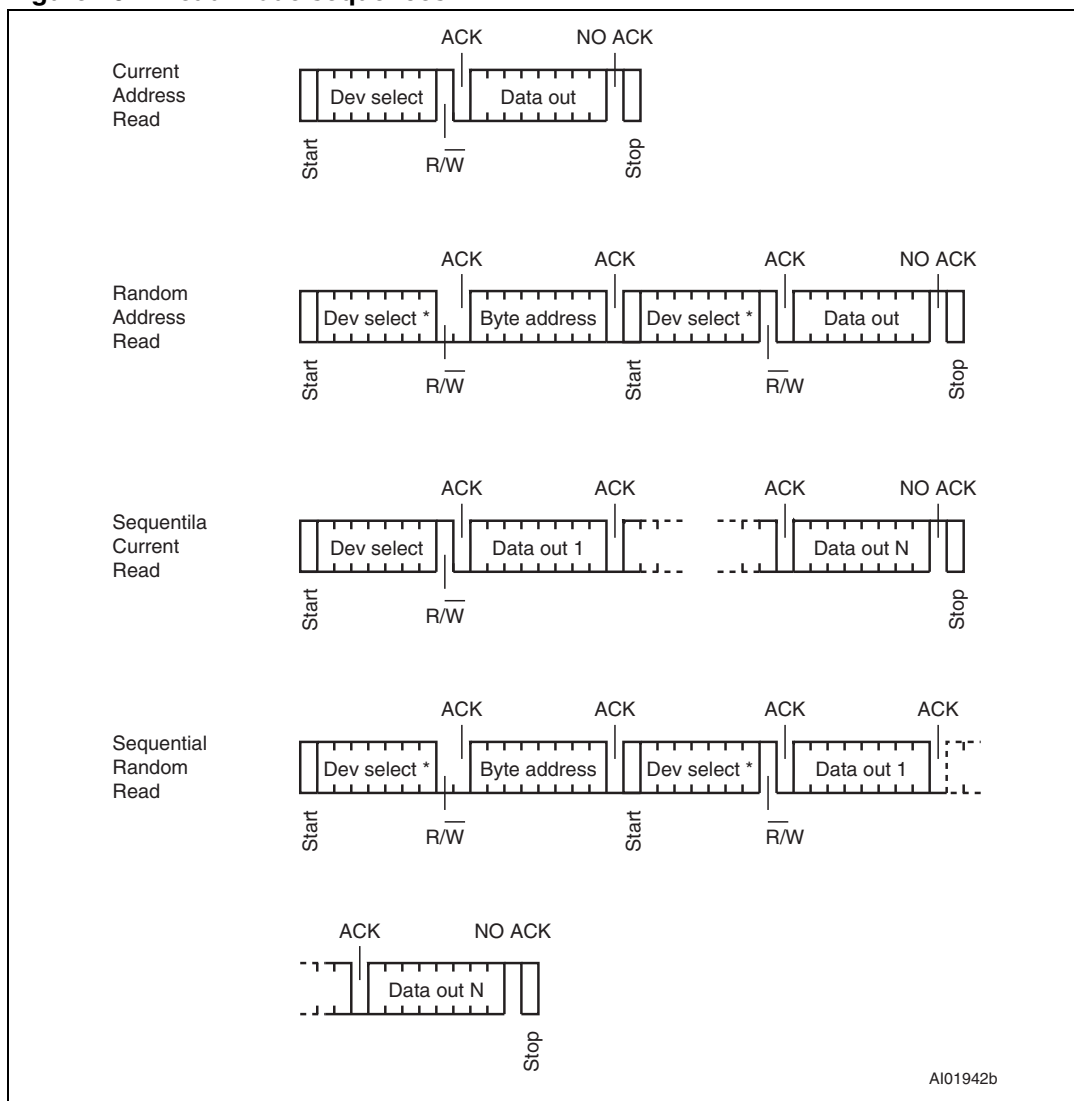

1. The seven most significant bits of the device select code of a Random Read (in the 1st and 3rd bytes) must be identical.

3.7 Read operations

Read operations are performed independently of the state of the Write Control (\overline{WC}) signal. The device has an internal address counter which is incremented each time a byte is read.

3.7.1 Random Address Read

A dummy Write is first performed to load the address into this address counter (as shown in [Figure 10](#)) but *without* sending a Stop condition. Then, the bus master sends another Start condition, and repeats the device select code, with the Read/Write bit (\overline{RW}) set to 1. The device acknowledges this, and outputs the contents of the addressed byte. The bus master must *not* acknowledge the byte, and terminates the transfer with a Stop condition.

3.7.2 Current Address Read

For the Current Address Read operation, following a Start condition, the bus master only sends a device select code with the Read/Write bit (\overline{RW}) set to 1. The device acknowledges this, and outputs the byte addressed by the internal address counter. The counter is then incremented. The bus master terminates the transfer with a Stop condition, as shown in [Figure 10](#), without acknowledging the byte.

3.7.3 Sequential Read

This operation can be used after a Current Address Read or a Random Address Read. The bus master *does* acknowledge the data byte output, and sends additional clock pulses so that the device continues to output the next byte in sequence. To terminate the stream of bytes, the bus master must *not* acknowledge the last byte, and *must* generate a Stop condition, as shown in [Figure 10](#).

The output data comes from consecutive addresses, with the internal address counter automatically incremented after each byte output. After the last memory address, the address counter 'rolls-over', and the device continues to output data from memory address 00h.

3.7.4 Acknowledge in Read mode

For all Read commands, the device waits, after each byte read, for an acknowledgment during the 9th bit time. If the bus master does not drive Serial Data (SDA) Low during this time, the device terminates the data transfer and switches to its Standby mode.

4 Initial delivery state

The device is delivered with all bits in the memory array set to 1 (each byte contains FFh).

5 Maximum rating

Stressing the device outside the ratings listed in [Table 5](#) may cause permanent damage to the device. These are stress ratings only, and operation of the device at these, or any other conditions outside those indicated in the operating sections of this specification, is not implied. Exposure to absolute maximum rating conditions for extended periods may affect device reliability. Refer also to the STMicroelectronics SURE program and other relevant quality documents.

Table 5. Absolute maximum ratings

Symbol	Parameter	Min.	Max.	Unit
	Ambient operating temperature	-40	130	°C
T _{STG}	Storage temperature	-65	150	°C
T _{LEAD}	Lead temperature during soldering	see note ⁽¹⁾		°C
	PDIP-specific lead temperature during soldering	-	260 ⁽²⁾	°C
I _{OL}	DC output current (SDA = 0)	-	5	mA
V _{IO}	Input or output range	-0.50	6.5	V
V _{CC}	Supply voltage	-0.50	6.5	V
V _{ESD}	Electrostatic discharge voltage (human body model) ⁽³⁾	-	4000	V

1. Compliant with JEDEC Std J-STD-020C (for small body, Sn-Pb or Pb assembly), the ST ECOPACK[®] 7191395 specification, and the European directive on Restrictions on Hazardous Substances (RoHS) 2002/95/EU.
2. T_{LEAD} max must not be applied for more than 10 s.
3. AEC-Q100-002 (compliant with JEDEC Std JESD22-A114, C1 = 100 pF, R1 = 1500 Ω, R2 = 500 Ω).

6 DC and AC parameters

This section summarizes the operating and measurement conditions, and the DC and AC characteristics of the device. The parameters in the DC and AC characteristic tables that follow are derived from tests performed under the measurement conditions summarized in the relevant tables. Designers should check that the operating conditions in their circuit match the measurement conditions when relying on the quoted parameters.

Table 6. Operating conditions (M24Cxx-W)

Symbol	Parameter	Min.	Max.	Unit
V_{CC}	Supply voltage	2.5	5.5	V
	Ambient operating temperature (device grade 6)	-40	85	°C
	Ambient operating temperature (device grade 3)	-40	125	°C

Table 7. Operating conditions (M24Cxx-R)

Symbol	Parameter	Min.	Max.	Unit
V_{CC}	Supply voltage	1.8	5.5	V
	Ambient operating temperature	-40	85	°C

Table 8. Operating conditions (M24Cxx-F)

Symbol	Parameter	Min.	Max.	Unit
V_{CC}	Supply voltage	1.7	5.5	V
	Ambient operating temperature	-20	85	°C

Table 9. DC characteristics (M24Cxx-W, device grade 6)

Symbol	Parameter	Test conditions (in addition to those in Table 6)	Min.	Max.	Unit
I_{LI}	Input leakage current (SCL, SDA, E0, E1, and E2)	$V_{IN} = V_{SS}$ or V_{CC} , device in Standby mode	-	± 2	μA
I_{LO}	Output leakage current	SDA in Hi-Z, external voltage applied on SDA: V_{SS} or V_{CC}	-	± 2	μA
I_{CC}	Supply current	$V_{CC} = 5 V$, $f_c = 400 kHz$ (rise/fall time < 50 ns)	-	2	mA
		$V_{CC} = 2.5 V$, $f_c = 400 kHz$ (rise/fall time < 50 ns)	-	1	mA
I_{CC1}	Standby supply current	Device not selected ⁽¹⁾ , $V_{IN} = V_{SS}$ or V_{CC} , for $2.5 V < V_{CC} \leq 5.5 V$	-	1	μA
V_{IL}	Input low voltage (SDA, SCL, \overline{WC})		-0.45	$0.3V_{CC}$	V
V_{IH}	Input high voltage (SDA, SCL, \overline{WC})		$0.7V_{CC}$	$V_{CC}+1$	V
V_{OL}	Output low voltage	$I_{OL} = 2.1 mA$ when $V_{CC} = 2.5 V$ or $I_{OL} = 3 mA$ when $V_{CC} = 5.5 V$	-	0.4	V

1. The device is not selected after a power-up, after a read command (after the Stop condition), or after the completion of the internal write cycle t_w (t_w is triggered by the correct decoding of a write command).

Table 10. DC characteristics (M24Cxx-W, device grade 3)

Symbol	Parameter	Test condition (in addition to those in Table 6)	Min.	Max.	Unit
I_{LI}	Input leakage current (SCL, SDA, E0, E1, and E2)	$V_{IN} = V_{SS}$ or V_{CC} , device in Standby mode	-	± 2	μA
I_{LO}	Output leakage current	SDA in Hi-Z, external voltage applied on SDA: V_{SS} or V_{CC}	-	± 2	μA
I_{CC}	Supply current	$V_{CC} = 5 V$, $f_c = 400 kHz$ (rise/fall time < 50 ns)	-	3	mA
		$V_{CC} = 2.5 V$, $f_c = 400 kHz$ (rise/fall time < 50 ns)	-	3	mA
I_{CC1}	Standby supply current	Device not selected ⁽¹⁾ , $V_{IN} = V_{SS}$ or V_{CC} , $V_{CC} = 5 V$	-	5	μA
		Device not selected ⁽¹⁾ , $V_{IN} = V_{SS}$ or V_{CC} , $V_{CC} = 2.5 V$	-	2	μA
V_{IL}	Input low voltage (SDA, SCL, \overline{WC})		-0.45	$0.3V_{CC}$	V
V_{IH}	Input high voltage (SDA, SCL, \overline{WC})		$0.7V_{CC}$	$V_{CC}+1$	V
V_{OL}	Output low voltage	$I_{OL} = 2.1 mA$ when $V_{CC} = 2.5 V$ or $I_{OL} = 3 mA$ when $V_{CC} = 5.5 V$	-	0.4	V

1. The device is not selected after a power-up, after a read command (after the Stop condition), or after the completion of the internal write cycle t_w (t_w is triggered by the correct decoding of a write command).

Table 11. DC characteristics (M24Cxx-R)

Symbol	Parameter	Test condition (in addition to those in Table 7)	Min.	Max.	Unit
I_{LI}	Input leakage current (SCL, SDA, E0, E1, and E2)	$V_{IN} = V_{SS}$ or V_{CC} , device in Standby mode	-	± 2	μA
I_{LO}	Output leakage current	SDA in Hi-Z, external voltage applied on SDA: V_{SS} or V_{CC}	-	± 2	μA
I_{CC}	Supply current	$V_{CC} = 1.8 V$, $f_c = 400 kHz$ (rise/fall time < 50 ns)	-	0.8	mA
I_{CC1}	Standby supply current	Device not selected ⁽¹⁾ , $V_{IN} = V_{SS}$ or V_{CC} , $V_{CC} = 1.8 V$	-	1	μA
V_{IL}	Input low voltage (SDA, SCL, \overline{WC})	$2.5 V \leq V_{CC}$	-0.45	$0.3 V_{CC}$	V
		$1.8 V \leq V_{CC} < 2.5 V$	-0.45	$0.25 V_{CC}$	V
V_{IH}	Input high voltage (SDA, SCL, \overline{WC})		$0.7V_{CC}$	$V_{CC}+1$	V
V_{OL}	Output low voltage	$I_{OL} = 0.7 mA$, $V_{CC} = 1.8 V$	-	0.2	V

1. The device is not selected after a power-up, after a read command (after the Stop condition), or after the completion of the internal write cycle t_W (t_W is triggered by the correct decoding of a write command).

Table 12. DC characteristics (M24Cxx-F)

Symbol	Parameter	Test condition (in addition to those in Table 8)	Min.	Max.	Unit
I_{LI}	Input leakage current (SCL, SDA, E0, E1, and E2)	$V_{IN} = V_{SS}$ or V_{CC} , device in Standby mode	-	± 2	μA
I_{LO}	Output leakage current	$V_{OUT} = V_{SS}$ or V_{CC} , SDA in Hi-Z	-	± 2	μA
I_{CC}	Supply current	$V_{CC} = 1.7 V$, $f_c = 400 kHz$ (rise/fall time < 50 ns)	-	0.8	mA
I_{CC1}	Standby supply current	Device not selected ⁽¹⁾ , $V_{IN} = V_{SS}$ or V_{CC} , $V_{CC} = 1.7 V$	-	1	μA
V_{IL}	Input low voltage (SDA, SCL, \overline{WC})	$2.5 V \leq V_{CC}$	-0.45	$0.3 V_{CC}$	V
		$1.7 V \leq V_{CC} < 2.5 V$	-0.45	$0.25 V_{CC}$	V
V_{IH}	Input high voltage (SDA, SCL, \overline{WC})		$0.7V_{CC}$	$V_{CC}+1$	V
V_{OL}	Output low voltage	$I_{OL} = 0.7 mA$, $V_{CC} = 1.7 V$	-	0.2	V

1. The device is not selected after a power-up, after a read command (after the Stop condition), or after the completion of the internal write cycle t_W (t_W is triggered by the correct decoding of a write command).

Table 13. AC measurement conditions

Symbol	Parameter	Min.	Max.	Unit
C_{bus}	Load capacitance	100		pF
	SCL input rise/fall time, SDA input fall time	-	50	ns
	Input levels	$0.2V_{CC}$ to $0.8V_{CC}$		V
	Input and output timing reference levels	$0.3V_{CC}$ to $0.7V_{CC}$		V

Figure 11. AC measurement I/O waveform

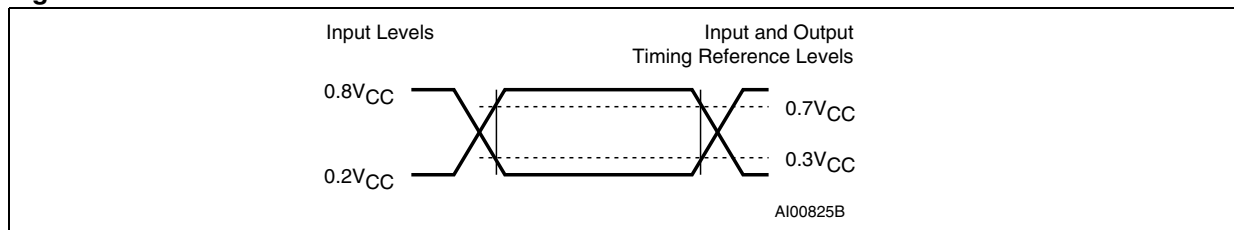

Table 14. Input parameters

Symbol	Parameter ⁽¹⁾	Test condition	Min.	Max.	Unit
C_{IN}	Input capacitance (SDA)		-	8	pF
C_{IN}	Input capacitance (other pins)		-	6	pF
Z_{WCL}	\overline{WC} input impedance	$V_{IN} < 0.3 V$	15	70	$k\Omega$
Z_{WCH}	\overline{WC} input impedance	$V_{IN} > 0.7V_{CC}$	500	-	$k\Omega$
t_{NS}	Pulse width ignored (input filter on SCL and SDA)	Single glitch	-	100	ns

1. Characterized only.

Table 15. AC characteristics at 400 kHz (I²C Fast-mode) (M24Cxx-W, M24Cxx-R, M24Cxx-F)

Test conditions specified in either Table 6 , Table 7 or Table 8 and Table 13					
Symbol	Alt.	Parameter	Min. ⁽¹⁾	Max. ⁽¹⁾	Unit
f _C	f _{SCL}	Clock frequency	-	400	kHz
t _{CHCL}	t _{HIGH}	Clock pulse width high	600	-	ns
t _{CLCH}	t _{LOW}	Clock pulse width low	1300	-	ns
t _{QL1QL2} ⁽²⁾	t _F	SDA (out) fall time	20 ⁽³⁾	120	ns
t _{XH1XH2}	t _R	Input signal rise time	(4)	(4)	ns
t _{XL1XL2}	t _F	Input signal fall time	(4)	(4)	ns
t _{DXCX}	t _{SU:DAT}	Data in set up time	100	-	ns
t _{CLDX}	t _{HD:DAT}	Data in hold time	0	-	ns
t _{CLQX}	t _{DH}	Data out hold time	100	-	ns
t _{CLQV} ⁽⁵⁾⁽⁶⁾	t _{AA}	Clock low to next data valid (access time)	200	900	ns
t _{CHDL}	t _{SU:STA}	Start condition setup time	600	-	ns
t _{DLCL}	t _{HD:STA}	Start condition hold time	600	-	ns
t _{CHDH}	t _{SU:STO}	Stop condition set up time	600	-	ns
t _{DHDL}	t _{BUF}	Time between Stop condition and next Start condition	1300	-	ns
t _W	t _{WR}	Write time	-	5	ms

1. All values are referred to V_{IL}(max) and V_{IH}(min).
2. Characterized only, not tested in production.
3. With C_L = 10 pF.
4. There is no min. or max. values for the input signal rise and fall times. It is however recommended by the I²C specification that the input signal rise and fall times be more than 20 ns and less than 300 ns when f_C < 400 kHz.
5. To avoid spurious Start and Stop conditions, a minimum delay is placed between SCL=1 and the falling or rising edge of SDA.
6. t_{CLQV} is the time (from the falling edge of SCL) required by the SDA bus line to reach either 0.3V_{CC} or 0.7V_{CC}, assuming that R_{bus} × C_{bus} time constant is within the values specified in [Figure 5](#).

Table 16. AC characteristics at 100 kHz (I²C Standard-mode)⁽¹⁾ (M24Cxx-W, M24Cxx-R, M24Cxx-F)

Test conditions specified in either Table 6 , Table 7 or Table 8 and Table 13					
Symbol	Alt.	Parameter	Min.	Max.	Unit
f _C	f _{SCL}	Clock frequency	-	100	kHz
t _{CHCL}	t _{HIGH}	Clock pulse width high	4	-	μs
t _{CLCH}	t _{LOW}	Clock pulse width low	4.7	-	μs
t _{XH1XH2}	t _R	Input signal rise time	-	1	μs
t _{XL1XL2}	t _F	Input signal fall time	-	300	ns
t _{QL1QL2} ⁽²⁾	t _F	SDA fall time	-	300	ns
t _{DXCX}	t _{SU:DAT}	Data in setup time	250	-	ns
t _{CLDX}	t _{HD:DAT}	Data in hold time	0	-	ns
t _{CLQX}	t _{DH}	Data out hold time	200	-	ns
t _{CLQV} ⁽³⁾	t _{AA}	Clock low to next data valid (access time)	200	3450	ns
t _{CHDX} ⁽⁴⁾	t _{SU:STA}	Start condition setup time	4.7	-	μs
t _{DLCL}	t _{HD:STA}	Start condition hold time	4	-	μs
t _{CHDH}	t _{SU:STO}	Stop condition setup time	4	-	μs
t _{DHDL}	t _{BUF}	Time between Stop condition and next Start condition	4.7	-	μs
t _W	t _{WR}	Write time	-	5	ms

1. Values recommended by the I²C bus Standard-mode specification for a robust design of the I²C bus application. Note that the M24xxx devices decode correctly faster timings as specified in [Table 15: AC characteristics at 400 kHz \(I²C Fast-mode\) \(M24Cxx-W, M24Cxx-R, M24Cxx-F\)](#).
2. Characterized only.
3. To avoid spurious Start and Stop conditions, a minimum delay is placed between SCL=1 and the falling or rising edge of SDA.
4. For a reStart condition, or following a Write cycle.

Figure 12. AC waveforms

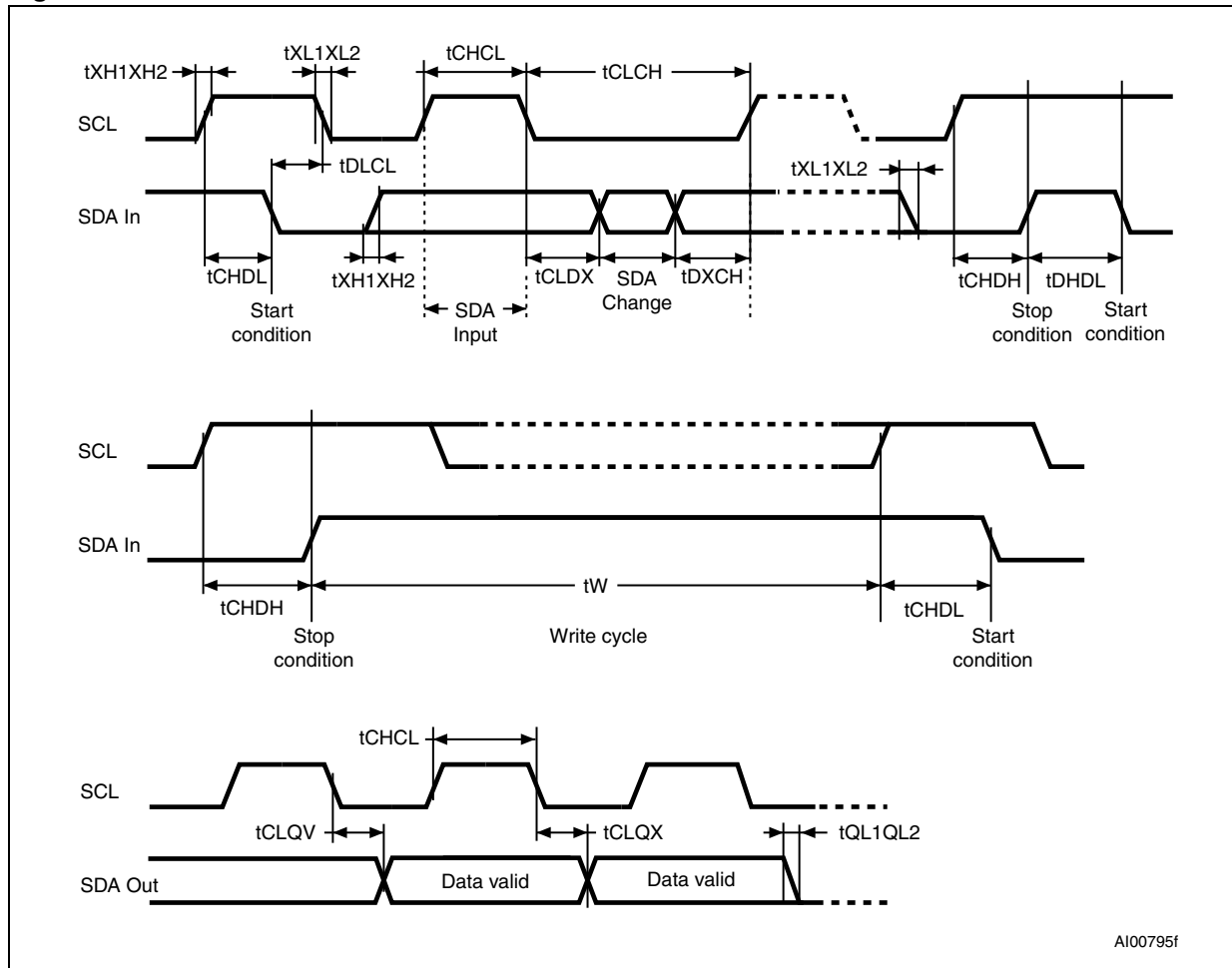

7 Package mechanical data

In order to meet environmental requirements, ST offers these devices in different grades of ECOPACK[®] packages, depending on their level of environmental compliance. ECOPACK[®] specifications, grade definitions and product status are available at: www.st.com. ECOPACK[®] is an ST trademark.

Figure 13. WLCSP (0.5 mm) and Thin WLCSP (0.3 mm) 0.4 mm pitch 5 bumps, package outline

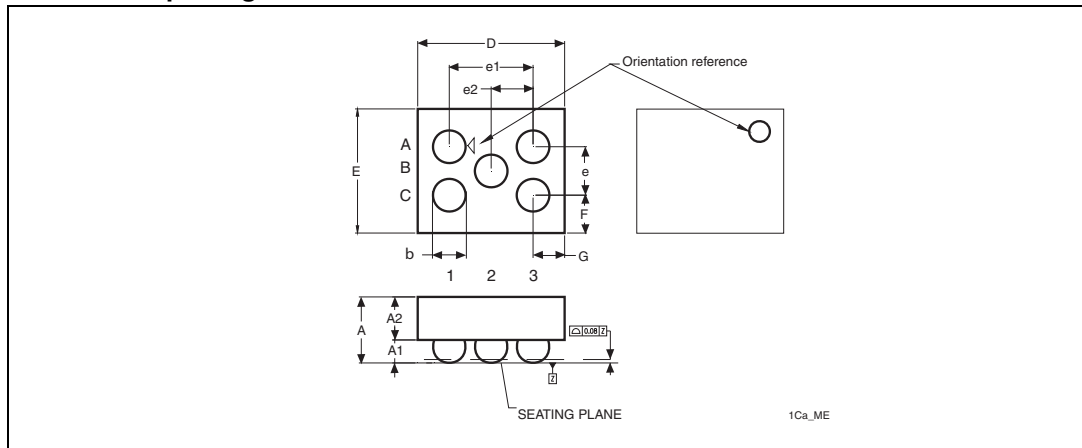

1. Drawing is not to scale.

Table 17. M24C08: WLCSP (0.5 mm height) 0.4 mm pitch, 5 bumps, package data

Symbol	millimeters			inches ⁽¹⁾		
	Typ	Min	Max	Typ	Min	Max
A	0.545	0.495	0.595	0.0215	0.0195	0.0234
A1	0.190	0.165	0.215	0.0075	0.0065	0.0085
A2	0.355	0.330	0.380	0.0140	0.0130	0.0150
b	0.270	0.240	0.300	0.0106	0.0094	0.0118
D	1.215	1.195	1.235	0.0478	0.0470	0.0486
E	1.025	1.005	1.045	0.0404	0.0396	0.0411
e	0.400	-	-	0.0157	-	-
e1	0.693	-	-	0.0273	-	-
e2	0.346	-	-	0.0136	-	-
F	0.313	-	-	0.0123	-	-
G	0.261	-	-	0.0103	-	-
N ⁽²⁾	5			5		

1. Values in inches are converted from mm and rounded to 4 decimal digits.

2. N is the total number of terminals.

Table 18. M24C08: Thin WLCSP (0.3 mm height), 0.4 mm pitch, 5 bumps, package data⁽¹⁾

Symbol	millimeters			inches ⁽²⁾		
	Typ	Min	Max	Typ	Min	Max
A	0.300	0.270	0.330	0.0118	0.0096	0.0140
A1	0.100	-	-	0.0039	-	-
A2	0.200	-	-	0.0079	-	-
b	0.160	-	-	0.0063	-	-
D	1.215	-	1.340	0.0478	-	0.0528
E	1.025	-	1.150	0.0404	-	0.0453
e	0.400	-	-	0.0157	-	-
e1	0.693	-	-	0.0273	-	-
e2	0.346	-	-	0.0136	-	-
F	0.313	-	-	0.0123	-	-
G	0.261	-	-	0.0103	-	-
N ⁽³⁾	5			5		

1. Preliminary data.
2. Values in inches are converted from mm and rounded to 4 decimal digits.
3. N is the total number of terminals.

Table 19. M24C16: WLCSP (0.5 mm height) 0.4 mm pitch, 5 bumps, package data⁽¹⁾

Symbol	millimeters			inches ⁽²⁾		
	Typ	Min	Max	Typ	Min	Max
A	0.545	0.495	0.595	0.0215	0.0195	0.0234
A1	0.190	0.165	0.215	0.0075	0.0065	0.0085
A2	0.355	0.330	0.380	0.0140	0.0130	0.0150
b	0.270	0.240	0.300	0.0106	0.0094	0.0118
D	1.255	1.235	1.275	0.0494	0.0486	0.0502
E	1.210	1.190	1.230	0.0476	0.0469	0.0484
e	0.400	-	-	0.0157	-	-
e1	0.693	-	-	0.0273	-	-
e2	0.346	-	-	0.0136	-	-
F	0.405	-	-	0.0159	-	-
G	0.281	-	-	0.0111	-	-
N ⁽³⁾	5			5		

1. Preliminary data.
2. Values in inches are converted from mm and rounded to 4 decimal digits.
3. N is the total number of terminals.

Figure 14. SO8 narrow – 8 lead plastic small outline, 150 mils body width, package outline

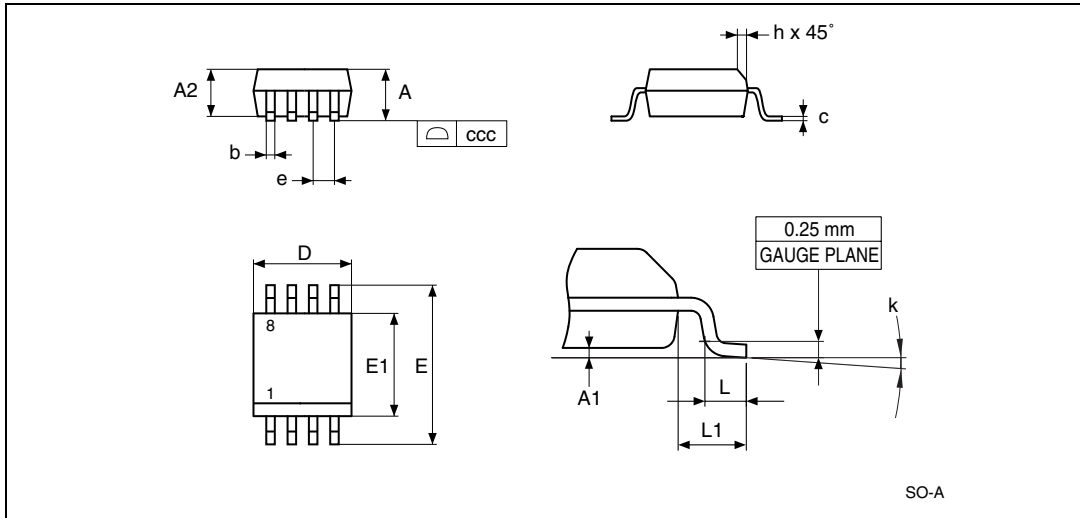

1. Drawing is not to scale.
2. The '1' that appears in the top view of the package shows the position of pin 1 and the 'N' indicates the total number of pins.

Table 20. SO8 narrow – 8 lead plastic small outline, 150 mils body width, package mechanical data

Symbol	millimeters			inches ⁽¹⁾		
	Typ	Min	Max	Typ	Min	Max
A	-	-	1.750	-	-	0.0689
A1	-	0.100	0.250	-	0.0039	0.0098
A2	-	1.250	-	-	0.0492	-
b	-	0.280	0.480	-	0.0110	0.0189
c	-	0.170	0.230	-	0.0067	0.0091
ccc	-	-	0.100	-	-	0.0039
D	4.900	4.800	5	0.1929	0.1890	0.1969
E	6.000	5.800	6.200	0.2362	0.2283	0.2441
E1	3.900	3.800	4.000	0.1535	0.1496	0.1575
e	1.270	-	-	0.0500	-	-
h	-	0.250	0.500	-	0.0098	0.0197
k	-	0°	8°	-	0°	8°
L	-	0.400	1.270	-	0.0157	0.0500
L1	1.040			0.0409		

1. Values in inches are converted from mm and rounded to 4 decimal digits.

Figure 15. UFDFPN8 (MLP8) 8-lead ultra thin fine pitch dual flat package no lead 2 x 3 mm, outline

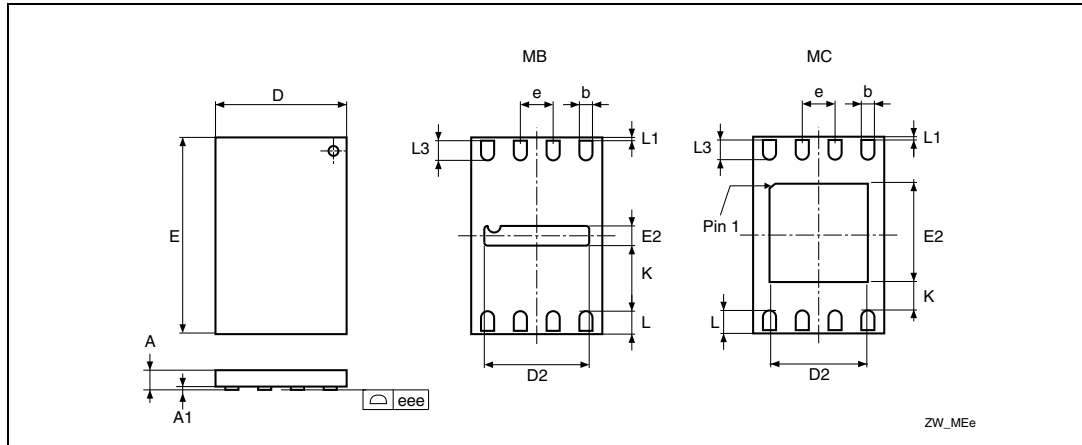

1. Drawing is not to scale.
2. The central pad (the area E2 by D2 in the above illustration) is pulled, internally, to V_{SS} . It must not be allowed to be connected to any other voltage or signal line on the PCB, for example during the soldering process.
3. The circle in the top view of the package indicates the position of pin 1.

Table 21. UFDFPN8 (MLP8) 8-lead ultra thin fine pitch dual flat package no lead 2 x 3 mm, data

Symbol	millimeters			inches ⁽¹⁾			Note
	Typ	Min	Max	Typ	Min	Max	
A	0.550	0.450	0.600	0.0217	0.0177	0.0236	
A1	0.020	0.000	0.050	0.0008	0.0000	0.0020	
b	0.250	0.200	0.300	0.0098	0.0079	0.0118	
D	2.000	1.900	2.100	0.0787	0.0748	0.0827	
D2 (MB)	1.600	1.500	1.700	0.0630	0.0591	0.0669	
D2 (MC)	-	1.200	1.600	-	0.0472	0.0630	
E	3.000	2.900	3.100	0.1181	0.1142	0.1220	
E2 (MB)	0.200	0.100	0.300	0.0079	0.0039	0.0118	
E2 (MC)	-	1.200	1.600	-	0.0472	0.0630	
e	0.500	-	-	0.0197	-	-	
K	-	0.300	-	-	0.0118	-	
L	-	0.300	0.500	-	0.0118	0.0197	
L1	-	-	0.150	-	-	0.0059	
L3	-	0.300	-	-	0.0118	-	
eee	0.080			0.0031			(2)

1. Values in inches are converted from mm and rounded to 4 decimal digits.
2. Applied for exposed die paddle and terminals. Excludes embedding part of exposed die paddle from measuring.

Figure 16. TSSOP8 – 8 lead thin shrink small outline, package outline

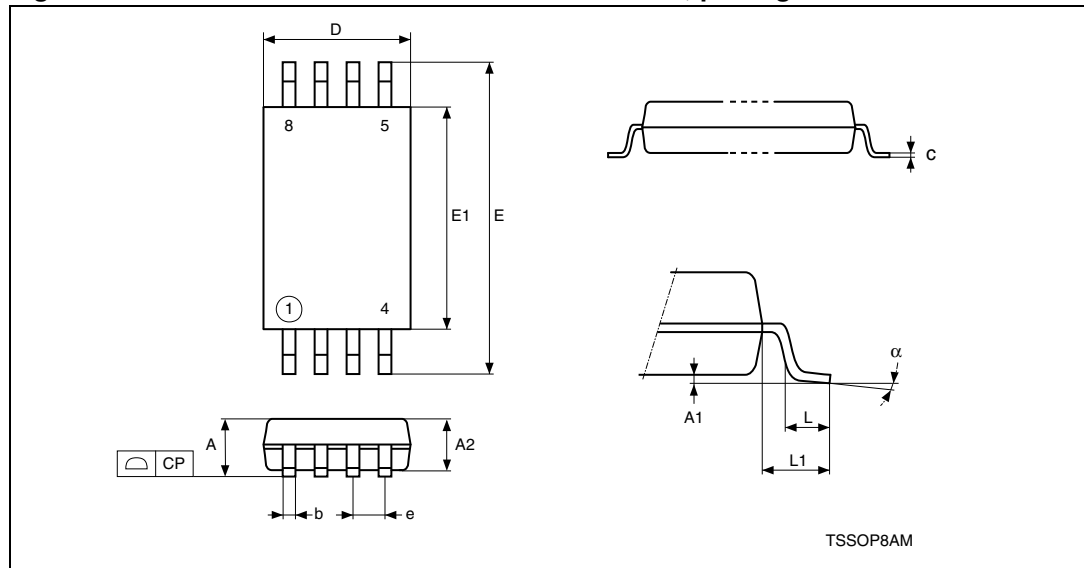

1. Drawing is not to scale.
2. The circle in the top view of the package indicates the position of pin 1.

Table 22. TSSOP8 – 8 lead thin shrink small outline, package mechanical data

Symbol	millimeters			inches ⁽¹⁾		
	Typ.	Min.	Max.	Typ.	Min.	Max.
A	-	-	1.200	-	-	0.0472
A1	-	0.050	0.150	-	0.0020	0.0059
A2	1.000	0.800	1.050	0.0394	0.0315	0.0413
b	-	0.190	0.300	-	0.0075	0.0118
c	-	0.090	0.200	-	0.0035	0.0079
CP	-	-	0.100	-	-	0.0039
D	3.000	2.900	3.100	0.1181	0.1142	0.1220
e	0.650	-	-	0.0256	-	-
E	6.400	6.200	6.600	0.2520	0.2441	0.2598
E1	4.400	4.300	4.500	0.1732	0.1693	0.1772
L	0.600	0.450	0.750	0.0236	0.0177	0.0295
L1	1.000	-	-	0.0394	-	-
α	-	0°	8°	-	0°	8°

1. Values in inches are converted from mm and rounded to 4 decimal digits.

Figure 17. PDIP8 – 8 pin plastic DIP, 0.25 mm lead frame, package outline

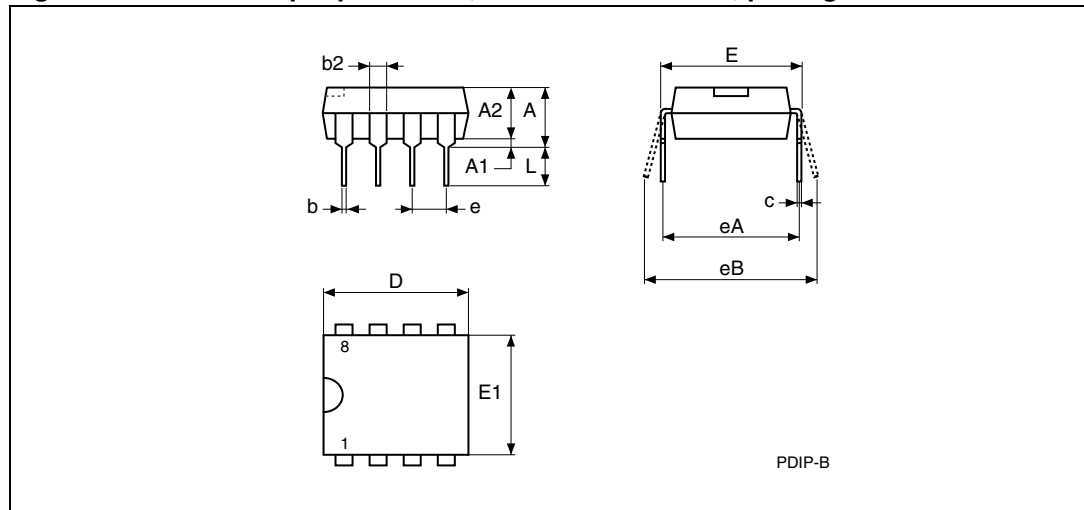

1. Drawing is not to scale.

Table 23. PDIP8 – 8 pin plastic DIP, 0.25 mm lead frame, package mechanical data

Symbol	millimeters			inches ⁽¹⁾		
	Typ.	Min.	Max.	Typ.	Min.	Max.
A	-	-	5.330	-	-	0.2098
A1	-	0.380	-	-	0.0150	-
A2	3.300	2.920	4.950	0.1299	0.1150	0.1949
b	0.460	0.360	0.560	0.0181	0.0142	0.0220
b2	1.520	1.140	1.780	0.0598	0.0449	0.0701
c	0.250	0.200	0.360	0.0098	0.0079	0.0142
D	9.270	9.020	10.160	0.3650	0.3551	0.4000
E	7.870	7.620	8.260	0.3098	0.3000	0.3252
E1	6.350	6.100	7.110	0.2500	0.2402	0.2799
e	2.540	-	-	0.1000	-	-
eA	7.600	-	-	0.3000	-	-
eB	-	-	10.920	-	-	0.4299
L	3.300	2.920	3.810	0.1299	0.1150	0.1500

1. Values in inches are converted from mm and rounded to 4 decimal digits.

8 Part numbering

Table 24. Ordering information scheme

Example:	M24C16	-	W	DW	3	T	P	/S
Device type M24 = I ² C serial access EEPROM								
Device Function 16 = 16 Kbit (2048 x 8) 08 = 8 Kbit (1024 x 8) 04 = 4 Kbit (512 x 8) 02 = 2 Kbit (256 x 8) 01 = 1 Kbit (128 x 8)								
Operating voltage W = V _{CC} = 2.5 V to 5.5 V (400 kHz) R = V _{CC} = 1.8 V to 5.5 V (400 kHz) F = V _{CC} = 1.7 V to 5.5 V (400 kHz)								
Package BN = PDIP8 MN = SO8 (150 mil width) MB or MC= UDFFPN8 (MLP8) DW = TSSOP8 (169 mil width) CS = WLCSP ⁽¹⁾ (Chip scale package) CT = Thin WLCSP ⁽²⁾ (Chip scale package)								
Device grade 6 = Industrial: device tested with standard test flow over -40 to 85 °C 3 = Automotive: device tested with high reliability certified flow ⁽³⁾ over -40 to 125 °C 5 = Consumer: device tested with standard test flow over -20 to 85 °C.								
Option T = Tape and reel packing								
Plating technology P or G = ECOPACK [®] (RoHS compliant)								
Process⁽⁴⁾ /S = F6SP36%								

1. Only M24C08 and M24C16 devices are offered in the WLCSP package.
2. Only M24C08-F devices are offered in the Thin WLCSP package.
3. ST strongly recommends the use of the Automotive Grade devices for use in an automotive environment. The High Reliability Certified Flow (HRCF) is described in the quality note QNEE9801. Please ask your nearest ST sales office for a copy.
4. Used only for device grade 3.

For a list of available options (speed, package, etc.) or for further information on any aspect of this device, please contact your nearest ST sales office.

9 Revision history

Table 25. Document revision history

Date	Version	Changes
10-Dec-1999	2.4	TSSOP8 Turned-Die package removed (p 2 and order information) Lead temperature added for TSSOP8 in table 2
18-Apr-2000	2.5	Labelling change to Fig-2D, correction of values for 'E' and main caption for Tab-13
05-May-2000	2.6	Extra labelling to Fig-2D
23-Nov-2000	3.0	SBGA package information removed to an annex document -R range changed to being the -S range, and the new -R range added
19-Feb-2001	3.1	SBGA package information put back in this document Lead Soldering Temperature in the Absolute Maximum Ratings table amended Write Cycle Polling Flow Chart using ACK illustration updated References to PSDIP changed to PDIP and Package Mechanical data updated Wording brought in to line with standard glossary
20-Apr-2001	3.2	Revision of DC and AC characteristics for the -S series
08-Oct-2001	3.3	Ball numbers added to the SBGA connections and package mechanical illustrations
09-Nov-2001	3.4	Specification of Test Condition for Leakage Currents in the DC Characteristics table improved
30-Jul-2002	3.5	Document reformatted using new template. SBGA5 package removed TSSOP8 (3x3mm ² body size) package (MSOP8) added. -L voltage range added
04-Feb-2003	3.6	Document title spelt out more fully. "W"-marked devices with $t_w=5ms$ added.
05-May-2003	3.7	-R voltage range upgraded to 400kHz working, and no longer preliminary data. 5V voltage range at temperature range 3 (-xx3) no longer preliminary data. -S voltage range removed. -Wxx3 voltage+temp ranged added as preliminary data.
07-Oct-2003	4.0	Table of contents, and Pb-free options added. Minor wording changes in Summary Description, Power-On Reset, Memory Addressing, Read Operations. $V_{IL}(min)$ improved to -0.45V. $t_W(max)$ value for -R voltage range corrected.
17-Mar-2004	5.0	MLP package added. Absolute Maximum Ratings for $V_{IO}(min)$ and $V_{CC}(min)$ changed. Soldering temperature information clarified for RoHS compliant devices. Device grade information clarified. Process identification letter "G" information added. 2.2-5.5V range is removed, and 4.5-5.5V range is now Not for New Design

Date	Version	Changes
7-Oct-2005	6.0	Product List summary table added. AEC-Q100-002 compliance. Device Grade information clarified. Updated Device internal reset section, Figure 4 , Figure 5 , Table 16 and Table 24 Added ECOPACK® information. Updated $t_W=5ms$ for the M24Cxx-W.
17-Jan-2006	7.0	Pin numbers removed from silhouettes (see on page 1). Internal Device Reset paragraph moved to below Section 2.4: Supply voltage (VCC) . Section 2.4: Supply voltage (VCC) added below Section 2: Signal description . Test conditions for V_{OL} updated in Table 9 and Table 10 SO8N package specifications updated (see Table 20) New definition of I_{CC1} over the whole V_{CC} range (see Tables 9, 10 and 11).
19-Sep-2006	8	Document converted to new ST template. SO8 and UFDFPN8 package specifications updated (see Section 7: Package mechanical data). Section 2.4: Supply voltage (VCC) clarified. I_{LI} value given with the device in Standby mode in Tables 9, 10 and 11 . Information given in Table 16: AC characteristics (M24Cxx-R and M24Cxx-F) are no longer preliminary data.
03-Aug-2007	9	1.7 V to 5.5 V V_{CC} voltage range added (M24C16-F, M24C08-F, M24C04-F part numbers added; Table 8 and Table 12 added). Section 2.4: Supply voltage (VCC) modified. Note 1 updated to latest standard revision in Table 5: Absolute maximum ratings . Rise/fall time conditions for I_{CC} modified in Table 9 , Table 10 and Table 11 . I_{CC1} conditions modified in Table 11: DC characteristics (M24Cxx-R) . Note removed below Table 14: Input parameters . t_W modified for M24Cxx-R in Table 16 , note added. TSSOP8 (DS) package specifications updated (see Table 23 and Figure 17). Added: Table 25 , Table 26 , Table 27 , Table 28 and Table 29 summarizing all available products. Table 24: Ordering information scheme : Blank option removed under Plating technology, /W removed under Process.
27-Sep-2007	10	Section 2.3: Chip Enable (E0, E1, E2) updated. Concerned signals specified for V_{IL} and V_{IH} parameters, and note removed in DC characteristics tables (Table 9 , Table 10 , Table 11 and Table 12). t_W modified in Table 16: AC characteristics (M24Cxx-R and M24Cxx-F) . M24C08-F and M24C04-F offered in UFDFPN8 package in the temperature range 5 (see Table 26 and Table 27).

Date	Version	Changes
30-Jan-2009	11	<p>Section 2.4: Supply voltage (VCC) clarified.</p> <p>Figure 5: Maximum RP value versus bus parasitic capacitance (C) for an I²C bus updated.</p> <p>I_{OL} added to Table 5: Absolute maximum ratings. ICC1 test conditions clarified in DC characteristics Table 9, Table 10, Table 11 and Table 12.</p> <p>Note modified below Table 14: Input parameters.</p> <p>t_{XH1XH2} and t_{XL1XL2} added to Table 15: AC characteristics at 400 kHz (I2C Fast-mode) (M24Cxx-W, M24Cxx-R, M24Cxx-F), note 4 removed.</p> <p>Figure 12: AC waveforms updated.</p> <p>WLCSP package added (refer to Figure 3 and Section 7: Package mechanical data).</p> <p>In Section 7: Package mechanical data:</p> <ul style="list-style-type: none"> – ECOPACK text added – inch values calculated from millimeters and rounded to four decimal digits – UDFPN package specifications updated <p>Small text changes.</p>
11-Mar-2009	12	<p>Timings for 100 kHz I²C Standard-mode added (see Table 16: AC characteristics at 100 kHz (I2C Standard-mode) (M24Cxx-W, M24Cxx-R, M24Cxx-F)).</p>
28-May-2009	13	<p>Added Thin WLCSP package.</p> <p>Added Table 19: M24C16: WLCSP (0.5 mm height) 0.4 mm pitch, 5 bumps, package data.</p> <p>Updated available devices in Table 25, Table 26, Table 27, Table 28, and Table 29.</p>
02-Mar-2010	14	<p>Package ECOPACK1 or ECOPACK2 category specified.</p> <p>Section 3.1: Start condition and Section 3.6: Write operations updated.</p> <p>I_{LO} test conditions modified in Table 9: DC characteristics (M24Cxx-W, device grade 6), Table 10: DC characteristics (M24Cxx-W, device grade 3) and Table 11: DC characteristics (M24Cxx-R).</p> <p>Table 15: AC characteristics at 400 kHz (I2C Fast-mode) (M24Cxx-W, M24Cxx-R, M24Cxx-F) modified.</p> <p>t_{DL1DL2} renamed as t_{QL1QL2} in Table 16: AC characteristics at 100 kHz (I2C Standard-mode) (M24Cxx-W, M24Cxx-R, M24Cxx-F).</p> <p>Figure 12: AC waveforms updated.</p>
01-Apr-2010	15	<p>Updated Figure 15: UDFPN8 (MLP8) 8-lead ultra thin fine pitch dual flat package no lead 2 x 3 mm, outline and Table 21 on page 30.</p> <p>Updated Table 13: AC measurement conditions.</p> <p>Updated Table 25 to Table 27.</p>

Date	Version	Changes
29-Apr-2010	16	<p>Deleted TSSOP8 3x3 mm package from cover page.</p> <p>Deleted Figure and Table relating to TSSOP8 3x3 mm package information.</p> <p>Deleted line and note in Table 24: Ordering information scheme concerning TSSOP8 3x3 mm package.</p> <p>In Table 26: Available M24C08 products (package, voltage range, temperature grade) updated UFDFPN8 (MC) package for M24C08-F range to 5 and deleted line concerning TSSOP8 3x3 mm package.</p> <p>In Table 27: Available M24C04 products (package, voltage range, temperature grade) updated UFDFPN8 (MC) package for M24C08-F range to 5.</p> <p>In Table 28: Available M24C02 products (package, voltage range, temperature grade) updated UFDRPN8 options to MB or MC.</p>
15-Apr-2011	17	<p>Updated:</p> <ul style="list-style-type: none"> - Text modified in Section 2.3: Chip Enable (E0, E1, E2). - Text modified in Section 3.6: Write operations. - V_{ESD} minimum value deleted of Table 5: Absolute maximum ratings. - Figure 15: UFDFPN8 (MLP8) 8-lead ultra thin fine pitch dual flat package no lead 2 x 3 mm, outline. - E2 (Rev MC): “ddd” has been changed to “eee” and its values modified in Table 21: UFDFPN8 (MLP8) 8-lead ultra thin fine pitch dual flat package no lead 2 x 3 mm, data. <p>Added:</p> <ul style="list-style-type: none"> - Note at the end of the Section 1: Description. - Figure footnote below the Figure 3: WLCSP and thin WLCSP connections (top view, marking side, with balls on the underside).

Please Read Carefully:

Information in this document is provided solely in connection with ST products. STMicroelectronics NV and its subsidiaries ("ST") reserve the right to make changes, corrections, modifications or improvements, to this document, and the products and services described herein at any time, without notice.

All ST products are sold pursuant to ST's terms and conditions of sale.

Purchasers are solely responsible for the choice, selection and use of the ST products and services described herein, and ST assumes no liability whatsoever relating to the choice, selection or use of the ST products and services described herein.

No license, express or implied, by estoppel or otherwise, to any intellectual property rights is granted under this document. If any part of this document refers to any third party products or services it shall not be deemed a license grant by ST for the use of such third party products or services, or any intellectual property contained therein or considered as a warranty covering the use in any manner whatsoever of such third party products or services or any intellectual property contained therein.

UNLESS OTHERWISE SET FORTH IN ST'S TERMS AND CONDITIONS OF SALE ST DISCLAIMS ANY EXPRESS OR IMPLIED WARRANTY WITH RESPECT TO THE USE AND/OR SALE OF ST PRODUCTS INCLUDING WITHOUT LIMITATION IMPLIED WARRANTIES OF MERCHANTABILITY, FITNESS FOR A PARTICULAR PURPOSE (AND THEIR EQUIVALENTS UNDER THE LAWS OF ANY JURISDICTION), OR INFRINGEMENT OF ANY PATENT, COPYRIGHT OR OTHER INTELLECTUAL PROPERTY RIGHT.

UNLESS EXPRESSLY APPROVED IN WRITING BY AN AUTHORIZED ST REPRESENTATIVE, ST PRODUCTS ARE NOT RECOMMENDED, AUTHORIZED OR WARRANTED FOR USE IN MILITARY, AIR CRAFT, SPACE, LIFE SAVING, OR LIFE SUSTAINING APPLICATIONS, NOR IN PRODUCTS OR SYSTEMS WHERE FAILURE OR MALFUNCTION MAY RESULT IN PERSONAL INJURY, DEATH, OR SEVERE PROPERTY OR ENVIRONMENTAL DAMAGE. ST PRODUCTS WHICH ARE NOT SPECIFIED AS "AUTOMOTIVE GRADE" MAY ONLY BE USED IN AUTOMOTIVE APPLICATIONS AT USER'S OWN RISK.

Resale of ST products with provisions different from the statements and/or technical features set forth in this document shall immediately void any warranty granted by ST for the ST product or service described herein and shall not create or extend in any manner whatsoever, any liability of ST.

ST and the ST logo are trademarks or registered trademarks of ST in various countries.

Information in this document supersedes and replaces all information previously supplied.

The ST logo is a registered trademark of STMicroelectronics. All other names are the property of their respective owners.

© 2011 STMicroelectronics - All rights reserved

STMicroelectronics group of companies

Australia - Belgium - Brazil - Canada - China - Czech Republic - Finland - France - Germany - Hong Kong - India - Israel - Italy - Japan - Malaysia - Malta - Morocco - Philippines - Singapore - Spain - Sweden - Switzerland - United Kingdom - United States of America

www.st.com