

3 Gbps, 2 differential-pair channel eSATA signal re-driver

Features

- Supports eSATA data rate of 1.5 Gbps and 3 Gbps
- Supports complete eSATA bus of two 2-wire differential-pair channels
- Squelch detector for validity of input differential signal
- Single operating supply (V_{CC}) range of $3.3\text{ V} \pm 10\%$
- Low power mode
- $100\ \Omega$ CML I/Os
- eSATA hot-plug capable
- Low capacitance on all channels
- 1-bit input equalizer regenerates the receiver attenuated signal
- 1-bit adjustable pre-emphasis and driver to drive the transmitter outputs over long PCB track lengths
- Low output skew and jitter
- Low ground bounce
- Available in QFN20 (4 x 4 mm) package footprint with flow-through pinout
- $-40\text{ }^{\circ}\text{C}$ to $85\text{ }^{\circ}\text{C}$ operating temperature range

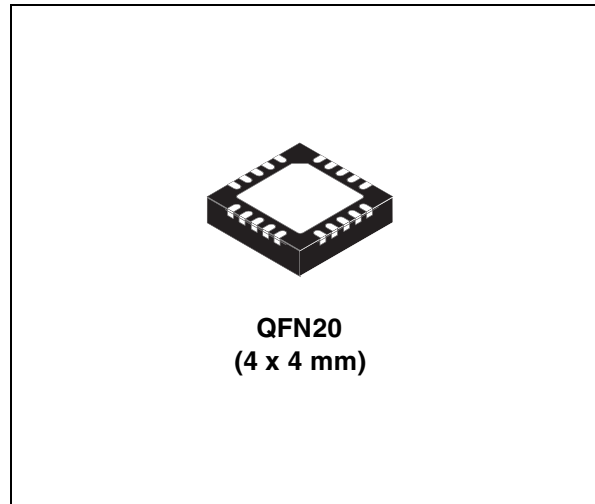

Table 1. Device summary

Order code	Package	Packing
STA1102RUTR	QFN20 (4 x 4 mm)	Tape and reel

Contents

- 1 Description 3**
- 2 Block diagram 4**
- 3 Functional description 7**
 - 3.1 Equalizer 7
 - 3.2 Pre-emphasis 7
 - 3.3 Input termination 8
 - 3.4 Low power modes 8
 - 3.4.1 Hardware low power mode 8
 - 3.4.2 Auto low power mode 8
 - 3.5 Squelch detector 8
- 4 Application diagram 9**
- 5 Absolute maximum ratings 10**
- 6 Thermal data 10**
- 7 Recommended operating conditions 11**
 - Electrical characteristics 11
- 8 Package mechanical data 14**
- 9 Revision history 17**



1 Description

The STA1102R is a serial data signal re-driver. It integrates two differential-pair channels suitable for eSATA signals up to a 3 Gbps data rate, in compliance with the SATA rev 2.6 specification.

An input detector is available at each channel, which constantly monitors the input signal level for output squelch functionality. If the detected differential input is below a defined threshold, the output is biased to the common mode voltage.

High-speed data paths and the flow-through pinout minimize internal device jitter and simplify board layout. The integrated input equalizer improves signal integrity at the receiver due to effects from lossy cables. A 1-bit adjustable pre-emphasis is also integrated to drive the transmitter outputs over long PCB track lengths.

The device can be set to a low-power mode by disabling the output current drivers through the EN pin.

2 Block diagram

Figure 1. STA1102R block diagram

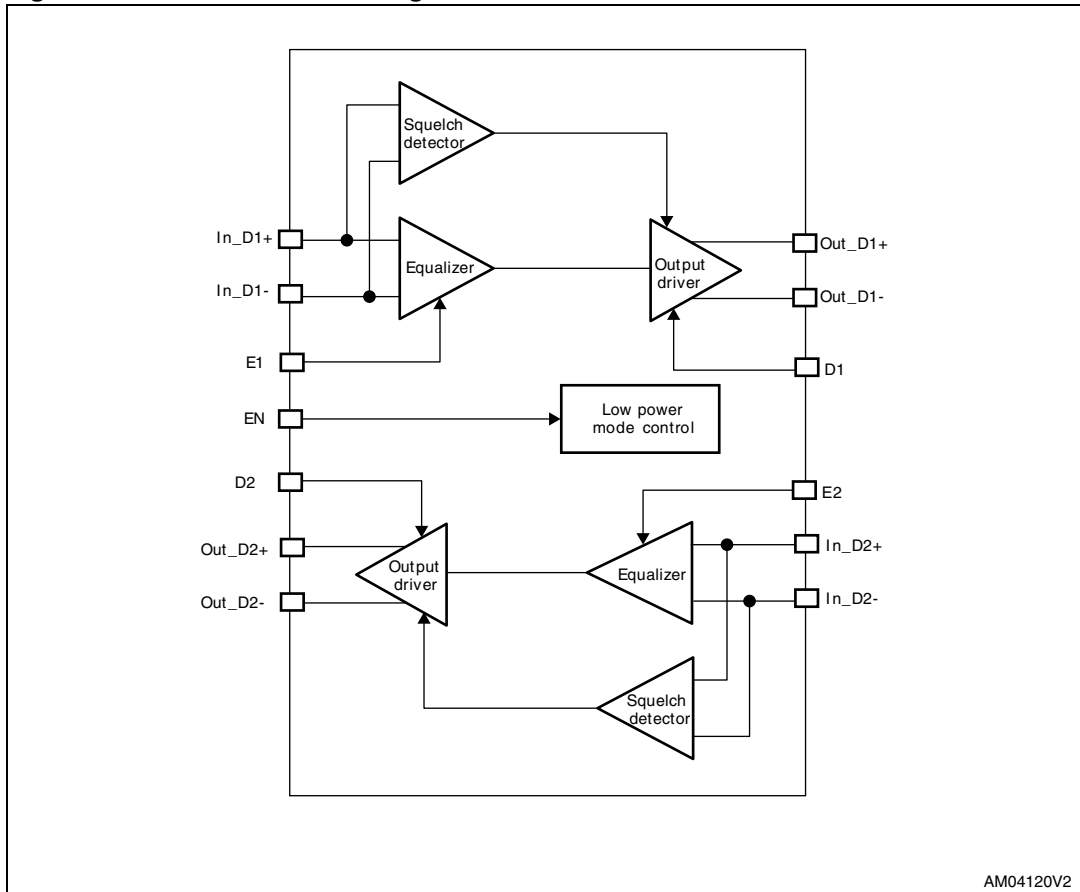

Figure 2. Pin configuration - top view

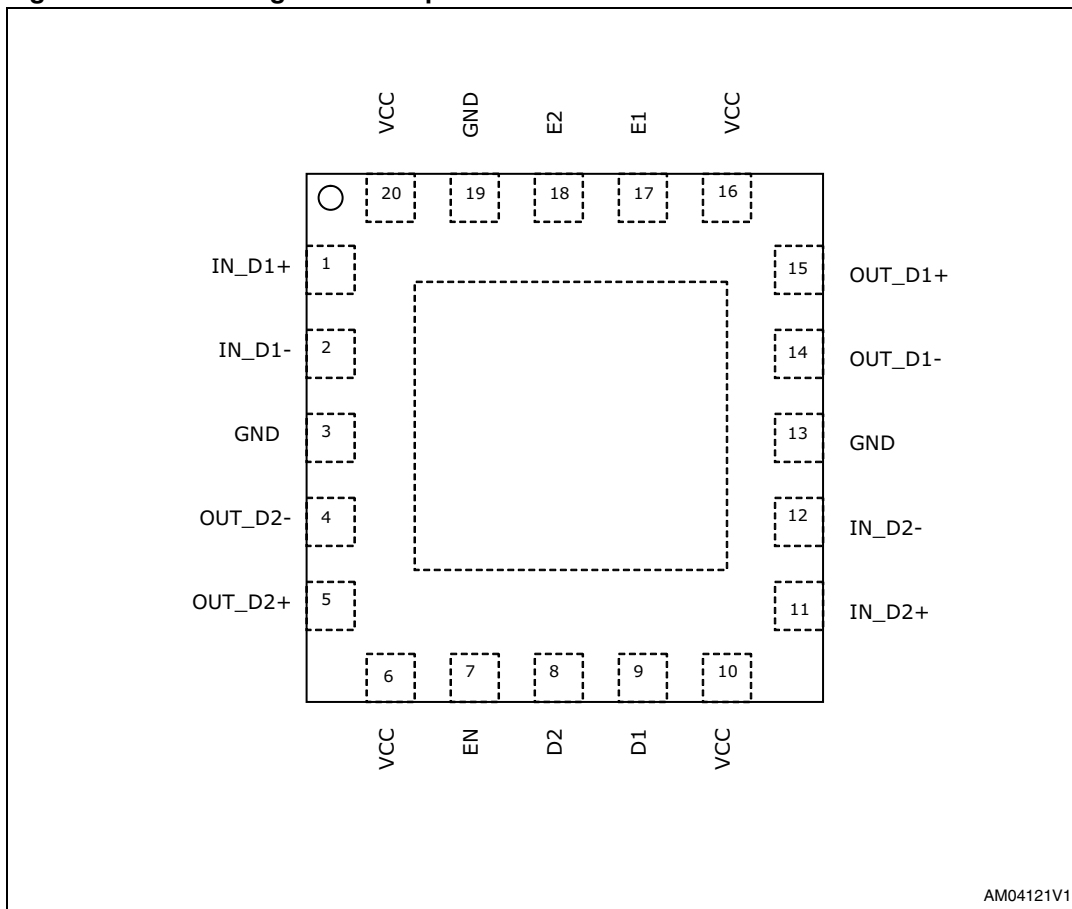

Table 2. Pin description

Pin number	Pin name	Type	Function
1	IN_D1+	Input	IN_D1+ makes a differential pair with IN_D1-
2	IN_D1-	Input	IN_D1- makes a differential pair with IN_D1+
3	GND	Power	Ground
4	OUT_D2-	Output	OUT_D2- makes a differential pair with OUT_D2+
5	OUT_D2+	Output	OUT_D2+ makes a differential pair with OUT_D2-
6	VCC	Power	3.3 V DC supply
7	EN	Input	Output driver enable pin; when low, device enters low power mode (internal 360 k Ω pull-up resistor to V _{CC})
8	D2	Input	Channel 2 pre-emphasis selection (internal 360 k Ω pull-down resistor to GND)
9	D1	Input	Channel 1 pre-emphasis selection (internal 360 k Ω pull-down resistor to GND)
10	VCC	Power	3.3 V DC supply
11	IN_D2+	Input	IN_D2+ makes a differential pair with IN_D2-
12	IN_D2-	Input	IN_D2- makes a differential pair with IN_D2+
13	GND	Power	Ground
14	OUT_D1-	Output	OUT_D1- makes a differential pair with OUT_D1+
15	OUT_D1+	Output	OUT_D1+ makes a differential pair with OUT_D1-
16	VCC	Power	3.3 V DC supply
17	E1	Input	Channel 1, input equalization selection (internal 360 k Ω pull down resistor to GND)
18	E2	Input	Channel 2, input equalization selection (internal 360 k Ω pull down resistor to GND)
19	GND	Power	Ground
20	VCC	Power	3.3 V DC supply

3 Functional description

3.1 Equalizer

The adjustable input equalizer reduces system jitter and attenuation from long or lossy cables. Shaping is performed by the gain stage of the equalizer to compensate the signal.

Table 3. Input equalizer truth table

EN	E1	E2	Function
0	x	x	Low power mode: input stage disabled for minimum power consumption
1	0	0	Normal operation mode: both CH1 and CH2 7dB EQ
1	0	1	Normal operation mode: CH1 7dB EQ; CH2 9dB EQ
1	1	0	Normal operation mode: CH1 9dB EQ; CH2 7dB EQ
1	1	1	Normal operation mode: both CH1 and CH2 9dB EQ

Note: 9 dB EQ is useful for signal recovery over long PCB track, e.g. 10" FR4.

3.2 Pre-emphasis

The STA1102R provides at each output a differential pair of 1-bit programmable pre-emphasis to compensate for losses across long PCB tracks and interconnects after the re-driver output. Below, the truth table of the pre-emphasis control is shown:

Table 4. Pre-emphasis truth table

EN	D1	D2	Functions
0	x	x	Low power mode: output driver disabled; output driven to HiZ
1	0	0	Normal operation mode: both CH1 and CH2 0 dB pre-emphasis
1	0	1	Normal operation mode: CH1 0 dB pre-emphasis; CH2 2.5 dB pre-emphasis
1	1	0	Normal operation mode: CH1 2.5 dB pre-emphasis; CH2 0 dB pre-emphasis
1	1	1	Normal operation mode: both CH1 and CH2 2.5 dB pre-emphasis

3.3 Input termination

The STA1102R integrates precise $50\ \Omega \pm 10\%$ termination resistors, pulled up to V_{CM} , on all its differential input channels. External terminations are not required. This gives improved performance and also minimizes the PCB board space. These on-chip termination resistors should match the differential characteristic impedance of the transmission line.

3.4 Low power modes

There are 2 types of low power modes in the STA1102R: hardware low and auto low power modes.

3.4.1 Hardware low power mode

The EN input activates a hardware low power mode. There is an internal pull-up resistor to maintain the EN in the default (HIGH) state. When this low power mode is activated (EN = L), all input and output buffers and internal bias circuitry are powered off and disabled. Outputs are driven to HiZ in low power mode. There is a delay associated with entering (max 2 μ s) and exiting (max 20 μ s) this hardware low power mode.

3.4.2 Auto low power mode

The auto low power mode is activated when differential voltage at either or both of the channels is $< 50\text{ mV}$ for more than 3 μ s. During this low power mode, output of the associated channel is driven to V_{cm} and the selective circuit block is disabled to lower power consumption. The delay associated with exiting the auto low power mode is 50 ns max.

3.5 Squelch detector

A squelch detector is integrated on the input of each of the 2 data paths. The squelch detector is a high-speed amplitude comparator that is turned on when EN = H. The differential input signal is monitored by the detector. When the differential input is detected to be less than or equal to 50 mV, the input signal is considered an invalid signal and is not passed to the output. When this happens, the corresponding output is biased to V_{CM} . When the differential input is greater than or equal to 150 mV, the input signal is considered valid signal and is passed to the output.

The integration of the squelch detector helps the system to prevent responding to noises. As such, it enables the device to fully support OOB signaling.

4 Application diagram

Figure 3. Typical application diagram

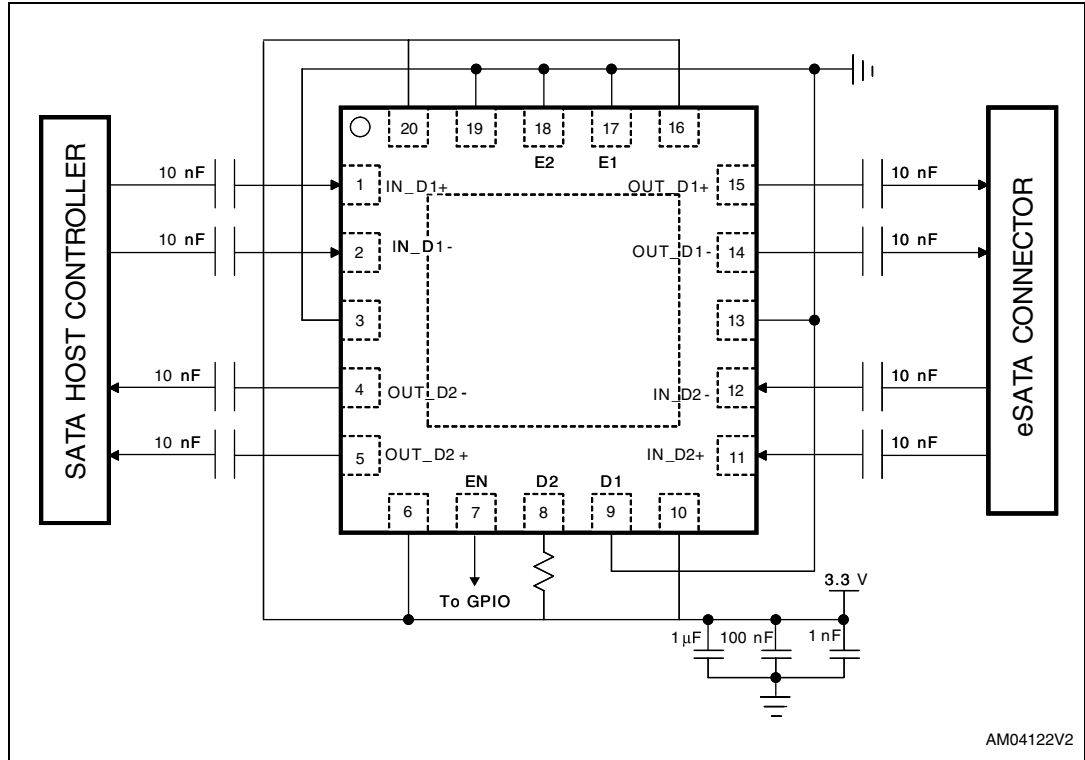

AM04122V2

Note: Typical circuit above is shown with CH1 Pre-Emp of 0 dB, EQ of 7 dB; CH2 Pre-Emp of 2.5 dB, EQ of 7 dB.

5 Absolute maximum ratings

Absolute maximum ratings are those values above which damage to the device may occur. Functional operation under these conditions is not implied. All voltages are referenced to GND.

Table 5. Absolute maximum ratings

Symbol	Parameter		Value	Unit
V_{CC}	Supply voltage to ground		-0.5 to + 4.0	V
V_I	Differential pair IOs voltage range		-0.5 to + 4.0	V
	Control IOs voltage range		-0.5 to + 4.0	V
T_{STG}	Storage temperature		-65 to + 150	°C
V_{ESD}	Electrostatic discharge voltage (human body model JESD22-A114C.01)	Differential input and output data pins	±12	kV
		All other pins	±8	

6 Thermal data

Table 6. QFN20 package thermal data

Symbol	Parameter	QFN20	Unit
θ_{JA}	Thermal coefficient (junction-ambient)	45	°C/Ω

7 Recommended operating conditions

Table 7. Recommended operating conditions

Symbol	Parameter	Test conditions	Min	Typ	Max	Unit
V_{CC}	Supply voltage	-	3.0	3.3	3.6	V
T_A	Operating ambient temperature	-	0	-	85	°C
C_C	Coupling capacitor	-	-	12	-	nF
D_R	Data rate	-	-	-	3.0	Gbps

Electrical characteristics

($T_A = 0$ to 85 °C, $V_{CC} = 3.0$ V to 3.6 V unless otherwise specified).

Table 8. DC electrical characteristic

Symbol	Parameter	Test conditions	Min	Typ	Max	Unit
General parameter characteristics						
$I_{CC_standby}$	Standby mode supply current	EN = L	-	-	300	μA
I_{CC_active}	Active mode supply current	$V_{DIFF_RX} = 700$ mV, K28.5 pattern running at 3 Gbps D1 = D2 = H	-	-	80	mA
$I_{CC_squelch}$		$V_{DIFF_RX} \leq V_{TH}$, EN = H D1 = D2 = H	-	-	45	mA
T_{PD}	Data propagation delay	-	-	-	400	ps
T_{DIS}	Device disable time	EN = H to L	-	-	2	μs
T_{EN}	Device enable time	EN = L to H	-	-	20	μs
Control logic characteristics						
V_{IH}	Input logic high voltage	-	1.4	-	-	V
V_{IL}	Input logic low voltage	-	-	-	0.5	V
I_{IH}	Input logic high current	-	-15	-	15	μA
I_{IL}	Input logic low current	-	-15	-	15	μA
Squelch detector characteristics						
V_{TH}	Squelch threshold voltage	-	50	-	150	mV _{pp}
T_{ENTER}	Squelch mode enter	-	-	-	5	ns
T_{EXIT}	Squelch mode exit	-	-	-	5	ns

Table 8. DC electrical characteristic (continued)

Symbol	Parameter	Test conditions	Min	Typ	Max	Unit
AC/DC specifications for receiver						
V_{DIFF_RX}	Differential input peak-to-peak voltage	$D_R = 3.0$ Gbps	200	-	1600	mV _{pp}
V_{CM_RX}	Common mode voltage	-	-	0	-	V
Z_{DIFF_RX}	Differential input impedance	-	85	100	115	Ω
Z_{SE_RX}	Single-ended input impedance	-	40	-	-	Ω
RL_{DIFF_RX}	Differential input return loss	f = 100 MHz to 300 MHz	18	-	-	dB
		f = 300 MHz to 600 MHz	14	-	-	dB
		f = 600 MHz to 1200 MHz	10	-	-	dB
		f = 1.2 GHz to 2.4 GHz	8	-	-	dB
		f = 2.4 GHz to 3.0 GHz	3	-	-	dB

Table 9. AC electrical characteristic

Symbol	Parameter	Test conditions	Min	Typ	Max	Unit
RL_{CM_RX}	Common mode input return loss	f = 100 MHz to 300 MHz	5	-	-	dB
		f = 300 MHz to 600 MHz	5	-	-	dB
		f = 600 MHz to 1200 MHz	2	-	-	dB
		f = 1.2 GHz to 2.4 GHz	1	-	-	dB
		f = 2.4 GHz to 3.0 GHz	1	-	-	dB
T_{R/F_RX}	Input rise/fall time	20% to 80%	67	-	136	ps
T_{Skew_RX}	Input differential skew	Mid-point of RX+ to mid-point of RX-	-	-	50	ps
AC/DC specifications for transmitter						
V_{DIFF_TX}	Differential output peak-to-peak voltage	f = 1.5 GHz; D1/D2 = L	400	-	600	mV _{pp}
		f = 1.5 GHz; D1/D2 = H	600	-	800	mV _{pp}
V_{CM_TX}	Common mode voltage	-	-	2.1	-	V
Z_{DIFF_TX}	Differential output impedance	-	85	100	115	Ω
Z_{SE_TX}	Single-ended output impedance	-	40	-	-	Ω
RL_{DIFF_TX}	Differential output return loss	f = 100 MHz to 300 MHz	14	-	-	dB
		f = 300 MHz to 600 MHz	8	-	-	dB
		f = 600 MHz to 1200 MHz	6	-	-	dB
		f = 1.2 GHz to 2.4 GHz	6	-	-	dB
		f = 2.4 GHz to 3.0 GHz	3	-	-	dB

Table 9. AC electrical characteristic (continued)

Symbol	Parameter	Test conditions	Min	Typ	Max	Unit
RL _{CM_TX}	Common mode output return loss	f = 100 MHz to 300 MHz	5	-	-	dB
		f = 300 MHz to 600 MHz	5	-	-	dB
		f = 600 MHz to 1200 MHz	2	-	-	dB
		f = 1.2 GHz to 2.4 GHz	1	-	-	dB
		f = 2.4 GHz to 3.0 GHz	1	-	-	dB
T _{R/F_TX}	Output rise/fall time	20% to 80%	67	-	136	ps
T _{Skew_TX}	Output differential skew	Mid-point of RX+ to mid-point of RX-	-	-	20	ps
T _{J_TX}	Total jitter	D _R = 3 Gbps; K28.5 pattern	-	0.2	0.3	U _{Ipp}
D _{J_TX}	Deterministic jitter	D _R = 3 Gbps; K28.5 pattern	-	0.13	0.2	U _{Ipp}
R _{J_TX}	Random jitter	D _R = 3 Gbps; K28.7 pattern	-	2.0	2.15	ps _{rms}

Figure 4. Jitter measurement setup

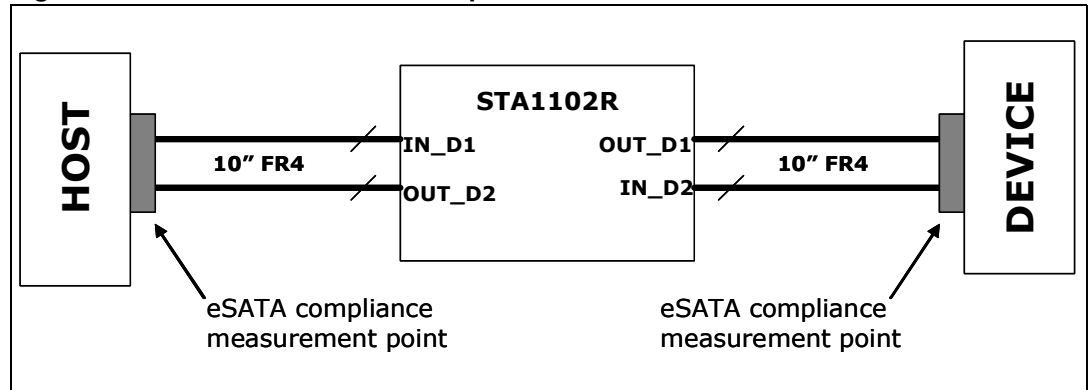

Table 10. STA1102RUTR
- mechanical data for QFN20 (4 x 4 x 0.8 mm) - pitch 0.5 mm

Symbol	Millimeters		
	Min	Typ	Max
A	0.70	0.75	0.80
A1	-	0.02	-
A2	-	0.65	-
A3	-	0.20	-
b	0.18	0.25	0.30
D	3.85	4.00	4.15
D2	See exposed pad variations		
E	3.85	4.00	4.15
E2	See exposed pad variations		
e	0.45	0.50	0.55
L	0.45	0.55	0.65

Table 11. STA1102RUTR - exposed pad variations

Variation	D2			E2		
	Min	Typ	Max	Min	Typ	Max
A	2.00	2.10	2.20	2.00	2.10	2.20

Figure 6. STA1102RUTR - footprint recommendation for QFN20 (4 x 4 x 0.8 mm) - pitch 0.5 mm

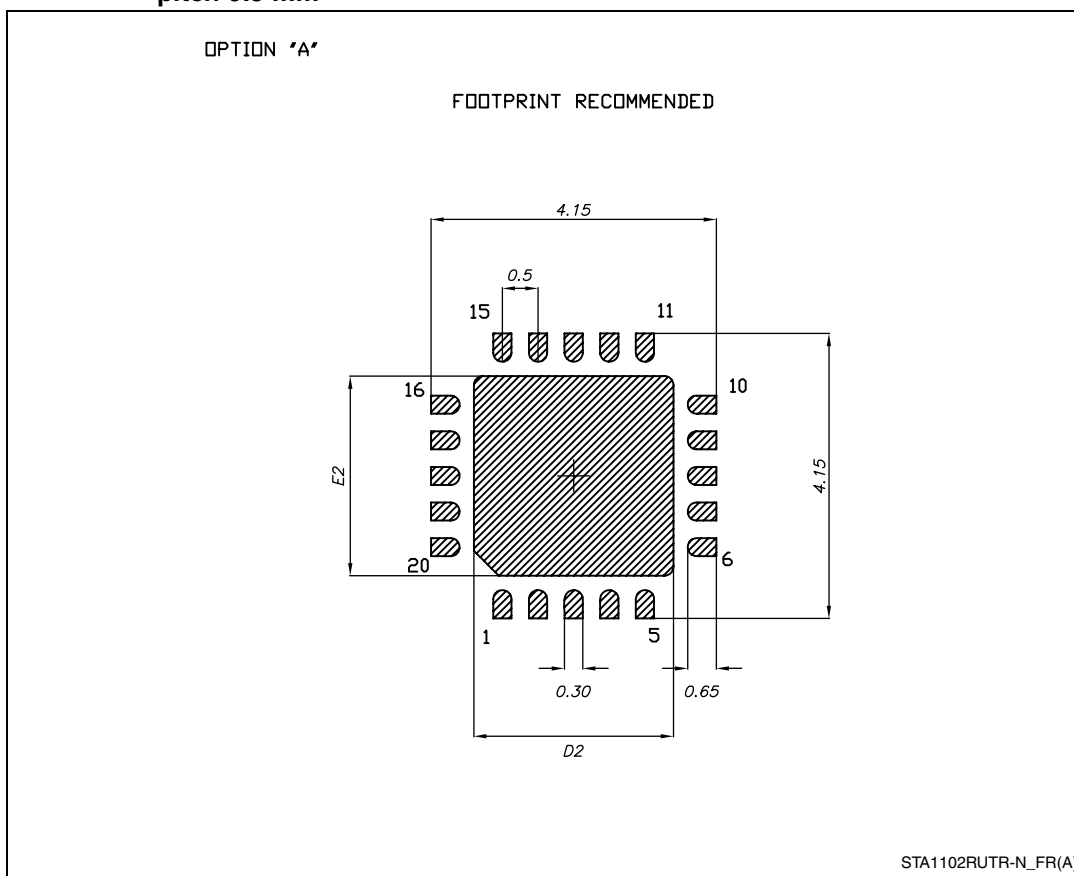

9 Revision history

Table 12. Document revision history

Date	Revision	Changes
19-Oct-2009	1	Initial release.
08-Jan-2010	2	Updated: Figure 1 , Figure 2 , Table 2 , Section 2.1 , Section Figure 3 . and Table 5 .
12-Mar-2010	3	Updated package information. Replaced D1 with D2 and D0 with D1.
04-Feb-2011	4	Document reformatted, added Contents , updated Table 5 , corrected typo in Figure 1 , Table 2 , Table 3 , Section 3.2 , Section 3.4.1 , Section 3.5 , Figure 3 , Figure 5 , Figure 6 , Table 8 , Table 11 .

Please Read Carefully:

Information in this document is provided solely in connection with ST products. STMicroelectronics NV and its subsidiaries ("ST") reserve the right to make changes, corrections, modifications or improvements, to this document, and the products and services described herein at any time, without notice.

All ST products are sold pursuant to ST's terms and conditions of sale.

Purchasers are solely responsible for the choice, selection and use of the ST products and services described herein, and ST assumes no liability whatsoever relating to the choice, selection or use of the ST products and services described herein.

No license, express or implied, by estoppel or otherwise, to any intellectual property rights is granted under this document. If any part of this document refers to any third party products or services it shall not be deemed a license grant by ST for the use of such third party products or services, or any intellectual property contained therein or considered as a warranty covering the use in any manner whatsoever of such third party products or services or any intellectual property contained therein.

UNLESS OTHERWISE SET FORTH IN ST'S TERMS AND CONDITIONS OF SALE ST DISCLAIMS ANY EXPRESS OR IMPLIED WARRANTY WITH RESPECT TO THE USE AND/OR SALE OF ST PRODUCTS INCLUDING WITHOUT LIMITATION IMPLIED WARRANTIES OF MERCHANTABILITY, FITNESS FOR A PARTICULAR PURPOSE (AND THEIR EQUIVALENTS UNDER THE LAWS OF ANY JURISDICTION), OR INFRINGEMENT OF ANY PATENT, COPYRIGHT OR OTHER INTELLECTUAL PROPERTY RIGHT.

UNLESS EXPRESSLY APPROVED IN WRITING BY AN AUTHORIZED ST REPRESENTATIVE, ST PRODUCTS ARE NOT RECOMMENDED, AUTHORIZED OR WARRANTED FOR USE IN MILITARY, AIR CRAFT, SPACE, LIFE SAVING, OR LIFE SUSTAINING APPLICATIONS, NOR IN PRODUCTS OR SYSTEMS WHERE FAILURE OR MALFUNCTION MAY RESULT IN PERSONAL INJURY, DEATH, OR SEVERE PROPERTY OR ENVIRONMENTAL DAMAGE. ST PRODUCTS WHICH ARE NOT SPECIFIED AS "AUTOMOTIVE GRADE" MAY ONLY BE USED IN AUTOMOTIVE APPLICATIONS AT USER'S OWN RISK.

Resale of ST products with provisions different from the statements and/or technical features set forth in this document shall immediately void any warranty granted by ST for the ST product or service described herein and shall not create or extend in any manner whatsoever, any liability of ST.

ST and the ST logo are trademarks or registered trademarks of ST in various countries.

Information in this document supersedes and replaces all information previously supplied.

The ST logo is a registered trademark of STMicroelectronics. All other names are the property of their respective owners.

© 2011 STMicroelectronics - All rights reserved

STMicroelectronics group of companies

Australia - Belgium - Brazil - Canada - China - Czech Republic - Finland - France - Germany - Hong Kong - India - Israel - Italy - Japan - Malaysia - Malta - Morocco - Philippines - Singapore - Spain - Sweden - Switzerland - United Kingdom - United States of America

www.st.com