

Low-voltage 0.6 Ω typ. single SPDT switch with break-before-make feature and 15 kV ESD protection

Datasheet – production data

Features

- Power-off and overvoltage protection
- Wide operating voltage range:
 $V_{CC} \text{ (opr)} = 1.65 \text{ to } 4.5 \text{ V}$
- Low ON-resistance $V_{IN} = 0 \text{ V}$:
 - $R_{ON} = 0.85 \Omega \text{ (max.) at } V_{CC} = 4.5 \text{ V}$
- Latch-up performance exceeds 300 mA JESD 17
- ESD performance tested on (D pin)
 - 8 kV IEC-61000-4-2 ESD, contact discharge
 - 15 kV IEC-61000-4-2 ESD, air discharge
- ESD performance test on all other pins
 - 3 kV human body model
 - 200 V machine model (IEC61340-3-2 level M2)
 - 1000 V charge device model (JESD22 C101)

Description

The STG4158 is a high-speed CMOS low-voltage single analog SPDT (single-pole dual throw) switch or 2:1 multiplexer/demultiplexer switch fabricated in silicon gate C²MOS technology. Designed to operate from 1.65 to 4.5 V, this device is ideal for portable applications.

It offers low ON-resistance (0.6 Ω) at $V_{CC} = 4.5 \text{ V}$ (typical $T_A = 25 \text{ }^\circ\text{C}$). The SEL input threshold is compatible with 1.8 V, and provides control to the switches.

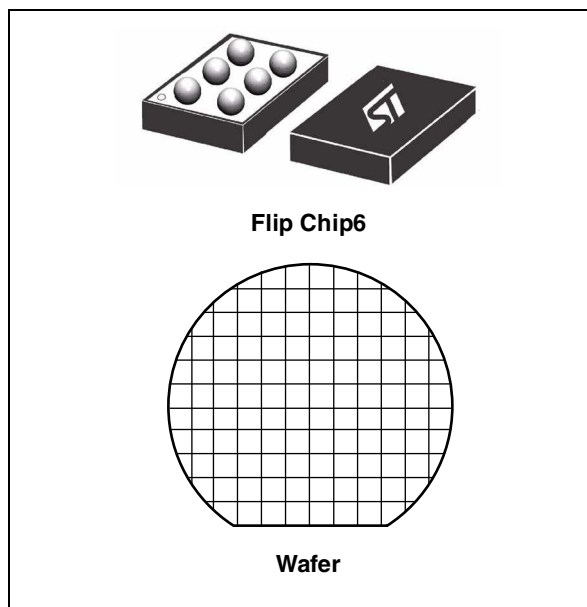

The switch S1 is ON (connected to common port D) when the SEL input is held high and OFF (high-impedance state exists between the two ports) when SEL is held low. The switch S2 is ON (connected to common port D) when the SEL input is held low and OFF (high-impedance state exists between the two ports) when SEL is held high.

The SEL input has an integrated weak pull-down resistor to prevent the SEL signal from floating. For low-power consumption, the SEL input must be grounded.

The STG4158 features power-off and overvoltage protection, enabling the device to be isolated during voltage fault events.

Table 1. Device summary

Order code	Package	Packing
STG4158BJR	Flip Chip6	Tape and reel
JSTG4158-CD1		Unsaun wafer

Contents

1	Logic diagram	5
2	Maximum rating	7
3	Electrical characteristics	8
4	Application information	12
5	Test circuits	13
6	Package mechanical data	17
7	Die description	21
8	Revision history	23

List of tables

Table 1.	Device summary	1
Table 2.	Truth table.	5
Table 3.	Pin description	6
Table 4.	Absolute maximum ratings	7
Table 5.	Recommended operating conditions	7
Table 6.	DC specifications	8
Table 7.	AC electrical characteristics ($C_L = 35 \text{ pF}$, $R_L = 50 \text{ } \Omega$, $t_r = t_f \leq 5 \text{ ns}$)	10
Table 8.	Analog switch characteristics ($C_L = 5 \text{ pF}$, $R_L = 50 \text{ } \Omega$, $T_A = 25 \text{ } ^\circ\text{C}$)	11
Table 9.	Voltage conditions	12
Table 10.	Flip Chip6 mechanical data	18
Table 11.	Pad information.	22
Table 12.	Document revision history	23

List of figures

Figure 1.	Functional diagram	5
Figure 2.	Input equivalent circuit	5
Figure 3.	Pin connection (bump side view)	6
Figure 4.	Voltage conditions	12
Figure 5.	ON-resistance	13
Figure 6.	Bandwidth	13
Figure 7.	OFF leakage	14
Figure 8.	Channel-to-channel crosstalk	14
Figure 9.	OFF isolation	15
Figure 10.	Test circuit	15
Figure 11.	Break-before-make time delay	16
Figure 12.	Switching time and charge injection ($V_{GEN} = 0\text{ V}$, $R_{GEN} = 0\ \Omega$, $R_L = 1\ \text{M}\Omega$, $C_L = 100\ \text{pF}$)	16
Figure 13.	Turn-ON, turn-OFF delay time	16
Figure 14.	Flip Chip6 package outline	17
Figure 15.	Footprint recommendation	18
Figure 16.	Flip Chip6 marking	18
Figure 17.	Flip Chip6 tape specification	19
Figure 18.	Flip Chip6 reel information	20
Figure 19.	JTS4158-CD1 die plot	21

1 Logic diagram

Figure 1. Functional diagram

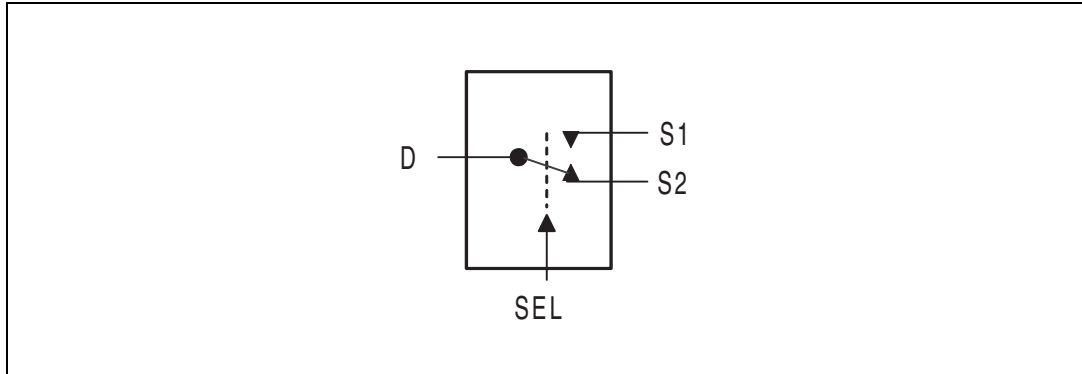
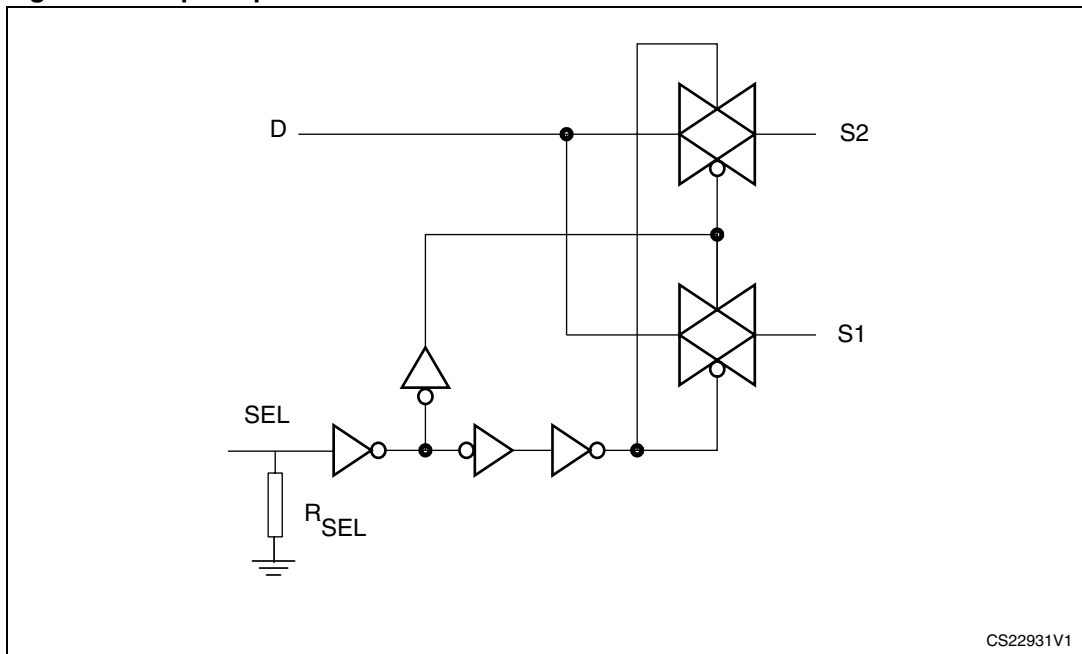

Figure 2. Input equivalent circuit



CS22931V1

Table 2. Truth table

SEL	Switch S1	Switch S2
H	ON	OFF ⁽¹⁾
L	OFF ⁽¹⁾	ON

1. High impedance.

Figure 3. Pin connection (bump side view)

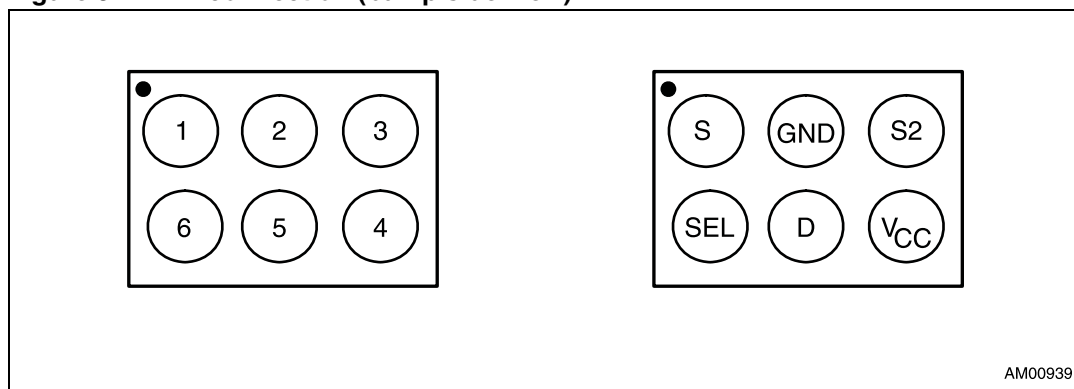

Table 3. Pin description

Flip Chip	Symbol	Name and function
1, 3	S1, S2	Independent channels
5	D	Common channel
6	SEL	Control
4	V _{CC}	Positive supply voltage
2	GND	Ground (0 V)

2 Maximum rating

Stressing the device above the ratings listed in [Table 4: Absolute maximum ratings](#) may cause permanent damage to the device. These are stress ratings only and operation of the device at these or any other conditions above those indicated in [Table 5: Recommended operating conditions](#) of this specification is not implied. Exposure to absolute maximum rating conditions for extended periods may affect device reliability. Refer also to the STMicroelectronics SURE program and other relevant quality documents.

Table 4. Absolute maximum ratings

Symbol	Parameter	Value	Unit
V_{CC}	Supply voltage	-0.5 to 5.5	V
V_I	DC input voltage	-0.5 to $V_{CC} + 0.5$	V
V_{IC}	DC control input voltage	-0.5 to 5.5	V
V_O	DC output voltage	-0.5 to $V_{CC} + 0.5$	V
I_{IKC}	DC input diode current on control pin ($V_{SEL} < 0$ V)	- 50	mA
I_{IK}	DC input diode current ($V_{SEL} < 0$ V)	± 50	mA
I_{OK}	DC output diode current	± 20	mA
I_O	DC output current	± 300	mA
I_{OP}	DC output current peak (pulse at 1 ms, 10% duty cycle)	± 500	mA
I_{CC} or I_{GND}	DC V_{CC} or ground current	± 100	mA
P_D	Power dissipation at $T_A = 70$ °C ⁽¹⁾	500	mW
T_{stg}	Storage temperature	-65 to 150	°C
T_L	Lead temperature (10 sec.)	260	°C

1. Derate above 70 °C by 18.5 mW/°C.

Table 5. Recommended operating conditions

Symbol	Parameter	Value	Unit
V_{CC}	Supply voltage	1.65 to 4.5	V
V_I	Input voltage	0 to V_{CC}	V
V_{IC}	Control input voltage	0 to V_{CC}	V
V_O	Output voltage	0 to V_{CC}	V
T_{op}	Operating temperature	-40 to 85	°C
dt/dv	Input rise and fall time control input	$V_{CC} = 1.65$ to 2.7 V	0 to 20
		$V_{CC} = 3.0$ to 4.5 V	0 to 10

3 Electrical characteristics

Table 6. DC specifications

Symbol	Parameter	V _{CC} (V)	Test condition	Value					Unit
				T _A = 25 °C			-40 to 85 °C		
				Min.	Typ.	Max.	Min.	Max.	
V _{IH}	High-level input voltage	1.65 – 1.95		0.9			0.9		V
		2.25 – 2.7		0.9			0.9		
		3.0 – 4.3		1.0			1.0		
		4.5		1.1			1.1		
V _{IL}	Low-level input voltage	1.65 – 1.95				0.6		0.6	V
		2.25 – 2.7				0.6		0.6	
		3.0 – 4.3				0.7		0.7	
		4.5				0.7		0.7	
R _{ON}	ON-resistance	1.65 – 2.20	V _S = 0 V to V _{CC} I _S = 100 mA		2.0			3.0	Ω
		2.25 – 3.6			0.9			1.3	
		3.7 – 4.5			0.6			0.85	
ΔR _{ON}	ON-resistance match between channels	1.65 – 2.20	V _S = 0 V to V _{CC} I _S = 100 mA		40			400	mΩ
		2.25 – 3.6			10			100	
		3.7 – 4.5			10			100	
R _{FLAT}	ON-resistance flatness	1.65 – 2.20	V _S = 0 V to V _{CC} I _S = 100 mA		1.2				Ω
		2.25 – 3.6			0.3			0.6	
		3.7 – 4.5			0.2			0.4	
R _{SEL}	SEL pull-down resistance	1.65 – 4.5			5000				kΩ
I _{OFF}	Sn OFF state leakage current	1.65 – 4.5	V _S = 0, V _D = V _{CC} V _S = V _{CC} , V _D = 0	-30		30	-300	300	nA
I _{ON}	Sn ON state leakage current	1.65 – 4.5	V _S = 0 to V _{CC} V _D = open	-20		20	-200	200	nA

Table 6. DC specifications (continued)

Symbol	Parameter	V _{CC} (V)	Test condition	Value					Unit
				T _A = 25 °C			-40 to 85 °C		
				Min.	Typ.	Max.	Min.	Max.	
I _D	D ON state leakage current	1.65 – 4.5	V _S = open V _D = 0 to V _{CC}	-30		30	-300	300	nA
		Floating	V _D = 0 - 4.5		10			25	μA
		0 – 0.5	V _D = 0 - 4.5		10			25	μA
		V _{CC} > 0.5	V _D ≥ V _{CC} + 0.4		10			25	μA
I _S	S ON state leakage current	1.65 – 4.5	V _S = 0 to V _{CC} V _D = open	-30		30	-300	300	nA
		Floating	V _S = 0 - 4.5		5			15	μA
		0 – 0.5	V _S = 0 - 4.5		5			15	μA
		V _{CC} > 0.5	V _S ≥ V _{CC} + 0.4		5			15	μA
I _{CC}	Quiescent supply current	2.5	V _{SEL} = V _{CC}		5.6			10	μA
		4.5			9			20	μA
		1.65 – 4.5	V _{SEL} = GND		0.05			0.1	μA
I _{SEL}	SEL leakage current	1.65 – 4.5	V _{SEL} = GND		0.1			1.0	μA
		2.5	V _{SEL} = V _{CC}		0.5			1.0	μA
		4.5	V _{SEL} = V _{CC}		1.0			2.0	μA
I _{CCLV}	Quiescent supply current low-voltage driving	4.5	V _{SEL} = 1.45 V		8			20	μA

Table 7. AC electrical characteristics ($C_L = 35 \text{ pF}$, $R_L = 50 \text{ } \Omega$, $t_r = t_f \leq 5 \text{ ns}$)

Symbol	Parameter	V_{CC} (V)	Test condition	Value					Unit
				$T_A = 25 \text{ } ^\circ\text{C}$			$-40 \text{ to } 85 \text{ } ^\circ\text{C}$		
				Min.	Typ.	Max.	Min.	Max.	
t_{PLH} , t_{PHL}	Propagation delay	1.65 – 1.95			0.13				ns
		2.25 – 2.7			0.15				
		3.0 – 3.6			0.16				
		3.7 – 4.5			0.16				
t_{ON}	Turn-on time	1.65 – 1.95	$V_S = V_{CC}$ $R_L = 50 \text{ } \Omega$ $C_L = 30 \text{ pF}$		112			160	ns
		2.25 – 2.7			64			86	
		3.0 – 3.6			43			58	
		3.7 – 4.5			28			38	
t_{OFF}	Turn-off time	1.65 – 1.95	$V_S = V_{CC}$ $R_L = 50 \text{ } \Omega$ $C_L = 30 \text{ pF}$		14			20	ns
		2.25 – 2.7			13			18	
		3.0 – 3.6			13			18	
		3.7 – 4.5			13			18	
t_D	Break-before-make time delay	1.65 – 1.95	$C_L = 35 \text{ pF}$ $R_L = 50 \text{ } \Omega$ $V_S = V_{CC}/2$	10	86				ns
		2.25 – 2.7		10	56				
		3.0 – 3.6		5	31				
		3.7 – 4.5		5	25				
Q	Charge injection	1.65 – 1.95	$C_L = 1 \text{ nF}$ $V_{GEN} = 0 \text{ V}$		70				pC
		2.25 – 2.7			140				
		3.0 – 3.6			190				
		3.7 – 4.5			230				

Table 8. Analog switch characteristics ($C_L = 5 \text{ pF}$, $R_L = 50 \text{ } \Omega$, $T_A = 25 \text{ } ^\circ\text{C}$)

Symbol	Parameter	V_{CC} (V)	Test condition	Value					Unit
				$T_A = 25 \text{ } ^\circ\text{C}$			$-40 \text{ to } 85 \text{ } ^\circ\text{C}$		
				Min.	Typ.	Max.	Min.	Max.	
OIRR	OFF-isolation (1)	1.65 – 4.5	$V_S = 1 \text{ V}_{RMS}$ $f = 100 \text{ kHz}$		-76				dB
			$V_S = 1 \text{ V}_{RMS}$ $f = 1 \text{ MHz}$		-55				
			$V_S = 1 \text{ V}_{RMS}$ $f = 5 \text{ MHz}$		-40				
Xtalk	Crosstalk	1.65 – 4.5	$V_S = 1 \text{ V}_{RMS}$ $f = 100 \text{ kHz}$		-81			dB	
			$V_S = 1 \text{ V}_{RMS}$ $f = 1 \text{ MHz}$		-61				
			$V_S = 1 \text{ V}_{RMS}$ $f = 5 \text{ MHz}$		-48				
THD	Total harmonic distortion	2.3 – 4.5	$R_L = 600 \text{ } \Omega$ $C_L = 50 \text{ pF}$ $V_S = V_{CC} V_{PP}$ $f = 600 \text{ Hz to } 20 \text{ kHz}$		0.015				%
BW	-3 dB bandwidth (switch ON)	1.65 – 4.5	$R_L = 50 \text{ } \Omega$		40				MHz
C_{SEL}	Control pin input capacitance	1.8 – 4.5	$V_L = V_{CC}$		30				pF
C_{Sn}	Sn port capacitance	1.8 – 4.5	$V_L = V_{CC}$		80				
C_D	D port capacitance when switch is enabled	1.8 – 4.5	$V_L = V_{CC}$		190				

1. OFF-isolation = $20 \log_{10} (V_D/V_S)$, V_D = output, V_S = input to OFF switch.

4 Application information

Power-off and overvoltage protection

The STG4158 has two operation modes:

1. Normal operation mode
2. Isolation mode

In normal operation mode, the switch functions as a normal SPDT, with the SEL pin that selects the switch to be either ON or OFF. Either S1 or S2 is connected to common channel D.

In isolation mode, all the switches are OFF. S1 or S2 are isolated from common channel D. The S1, S2, D ports have a 1 MΩ impedance to ground.

The operation modes are made possible by special detection circuitry that detects the voltage level at D, S1 and S2 supplies. Depending on these voltage levels, the device goes into isolation mode or normal operation mode accordingly.

Isolation mode is a feature of the device that is useful during fault conditions that occur in the application environment.

Table 9. Voltage conditions

V_{CC}	$V_{D,S}$ (voltage at common port D, S1 or S2)	Voltage condition	Mode
Floating	0 – 4.5 V	All switches OFF - S1, S2 and D are isolated from each other.	Isolation
0 – 0.5 V	0 – 4.5 V	All switches OFF - S1, S2 and D are isolated from each other.	Isolation
$V_{CC} > 0.5$	$V_{D,S} > V_{CC} + 0.4$	All switches OFF - S1, S2 and D are isolated from each other.	Isolation
1.65 – 4.5 V	0 – V_{CC}	Either S1 or S2 is connected to D, depending on SEL input.	Normal

Figure 4. Voltage conditions

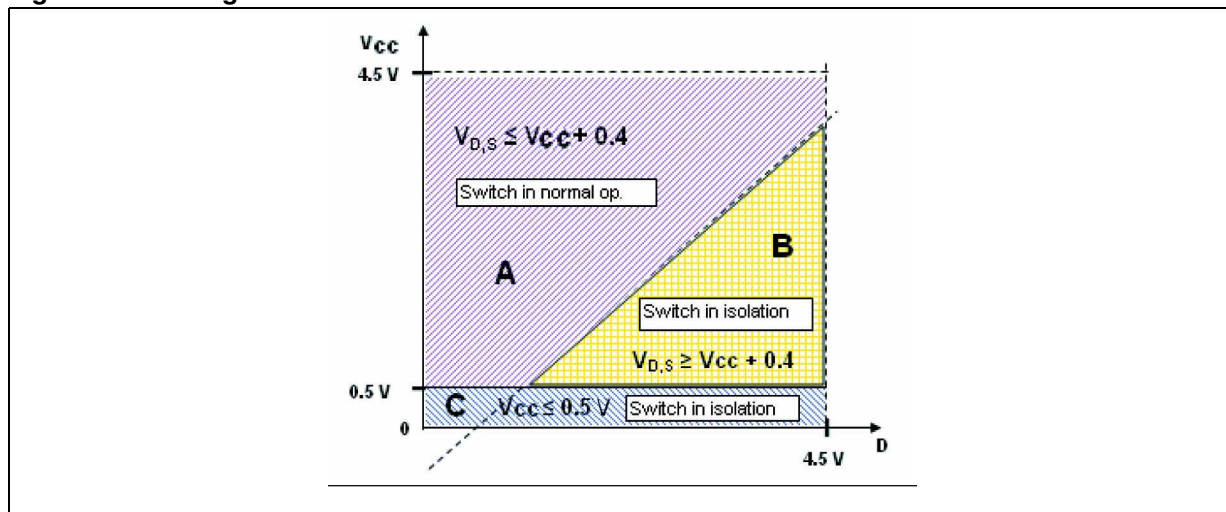

The SEL input has an integrated weak pull-down resistor R_{SEL} to prevent the SEL signal from floating. For lower power consumption, the SEL input must be grounded.

5 Test circuits

Figure 5. ON-resistance

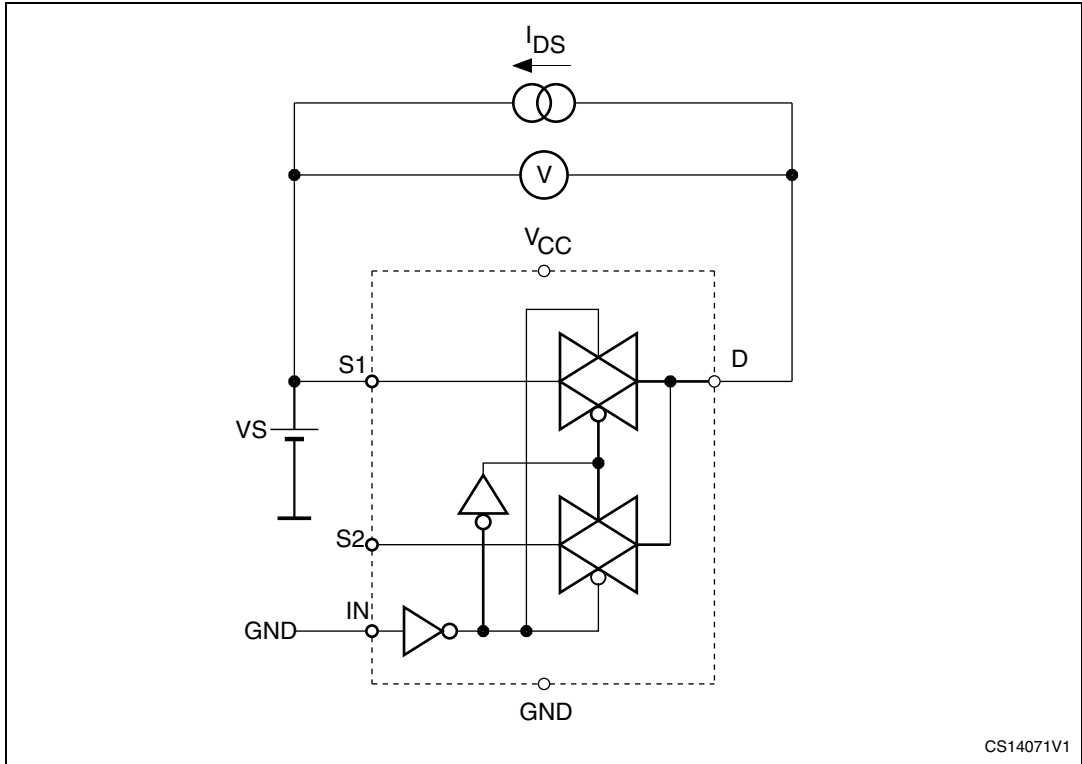

Figure 6. Bandwidth

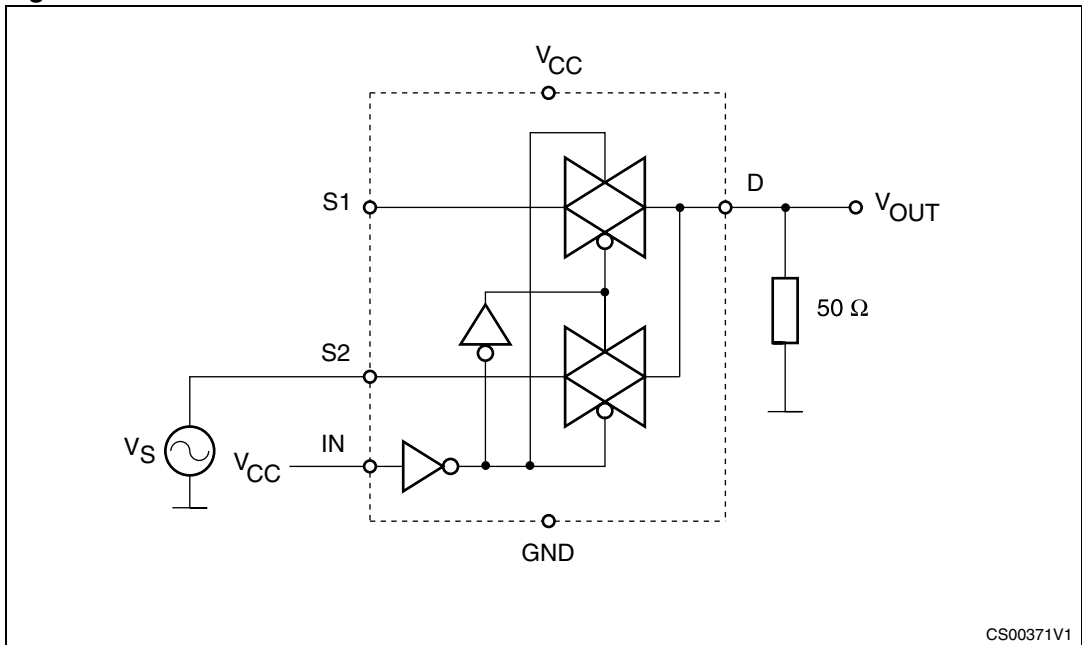

Figure 7. OFF leakage

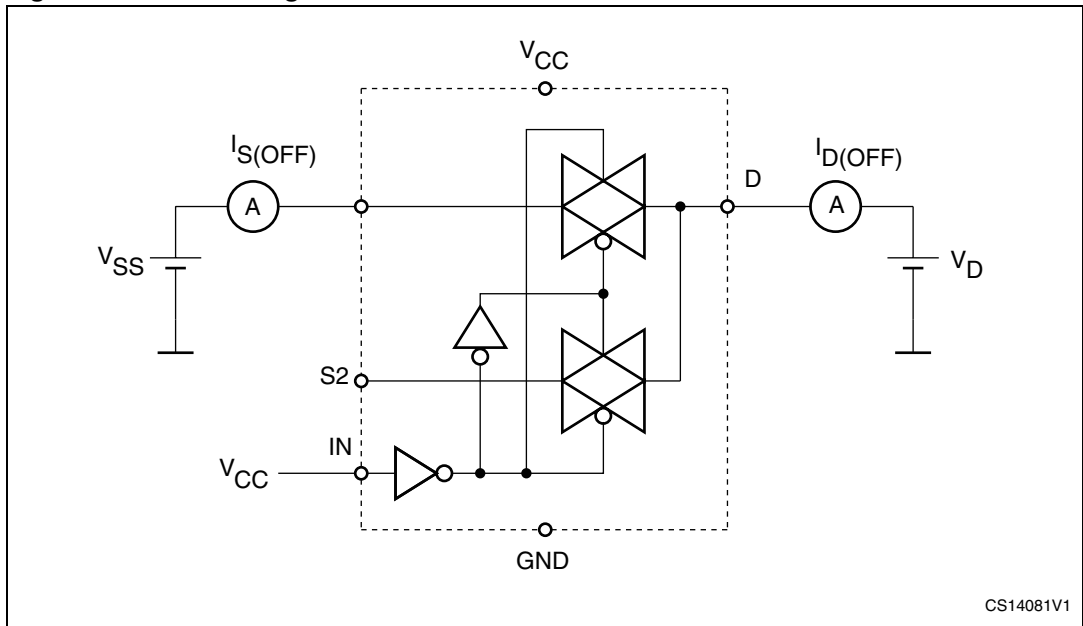

Figure 8. Channel-to-channel crosstalk

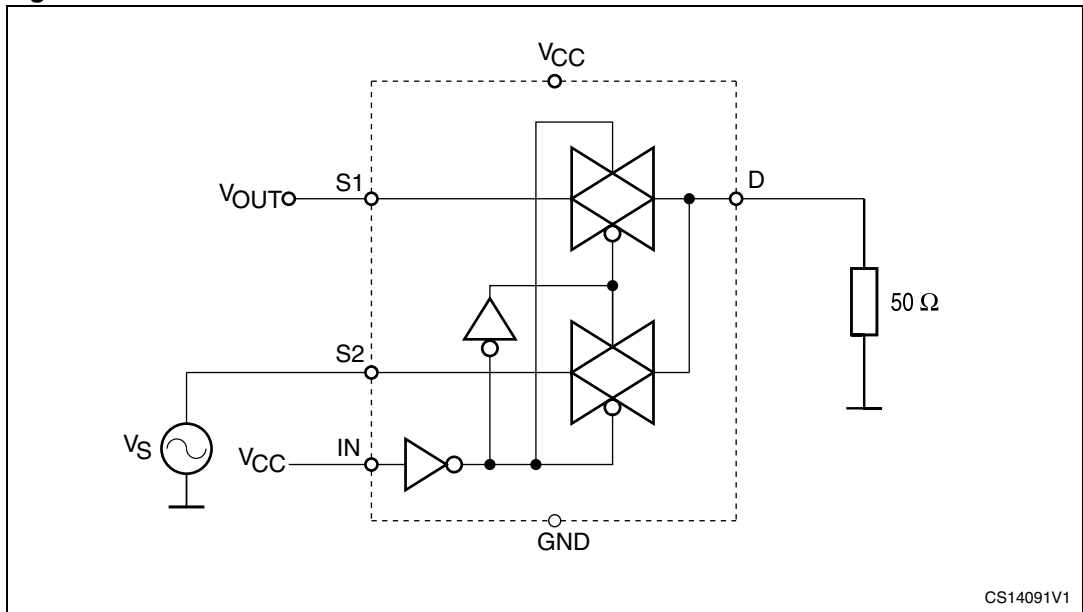

Figure 9. OFF isolation

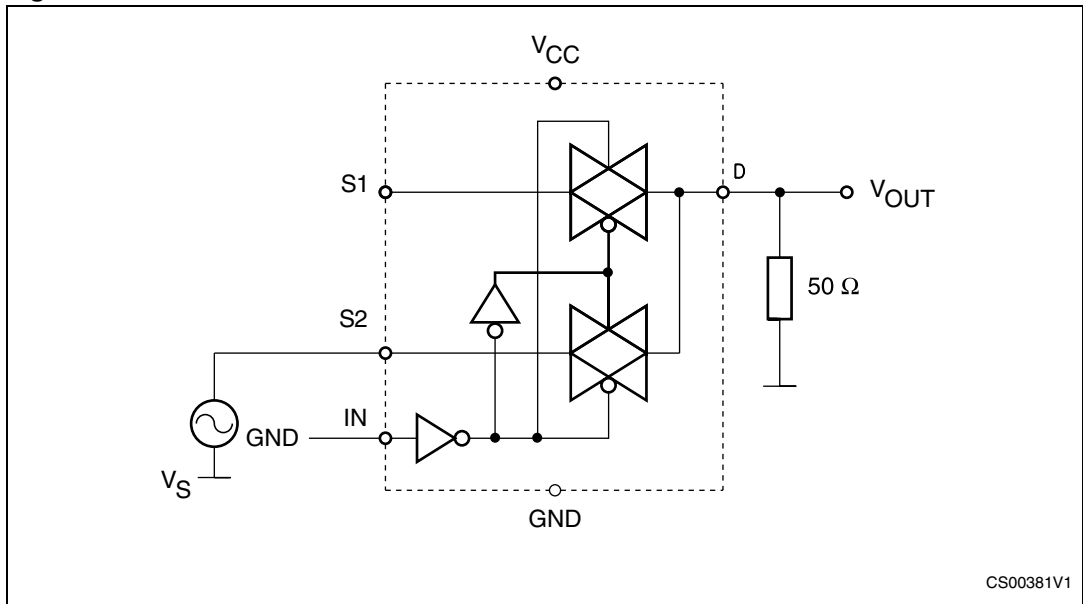
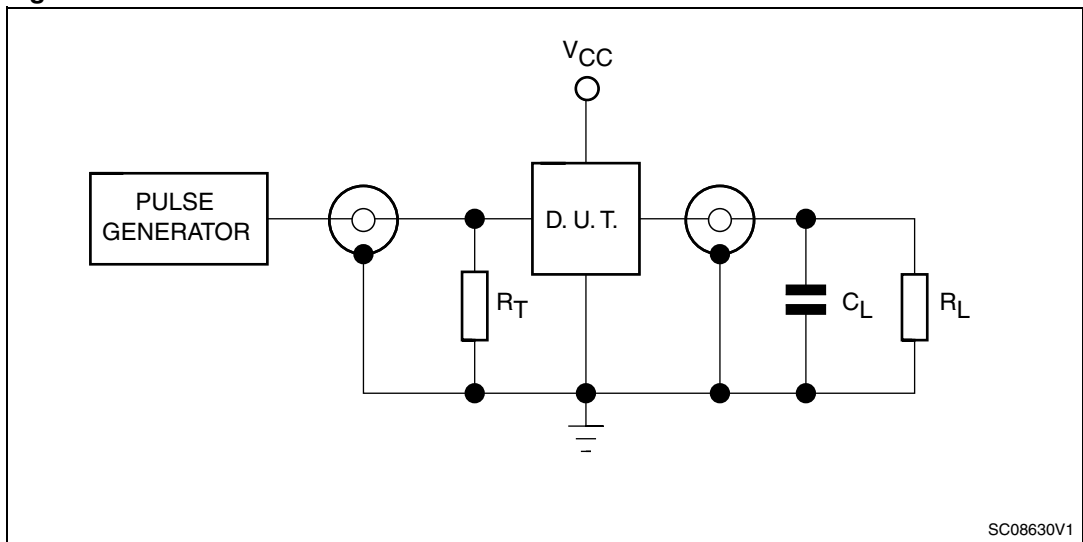

Figure 10. Test circuit



1. $C_L = 5/35\ \text{pF}$ or equivalent: (includes jig capacitance).
2. $R_L = 50\ \Omega$ or equivalent.
3. $R_T = Z_{OUT}$ of pulse generator (typically $50\ \Omega$).

Figure 11. Break-before-make time delay

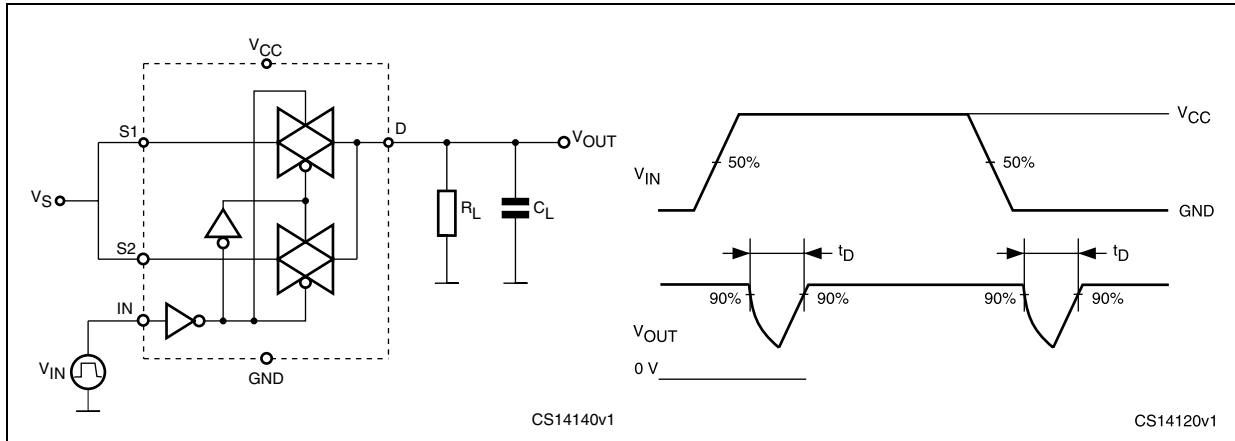

Figure 12. Switching time and charge injection
 ($V_{GEN} = 0\text{ V}$, $R_{GEN} = 0\ \Omega$, $R_L = 1\text{ M}\Omega$, $C_L = 100\text{ pF}$)

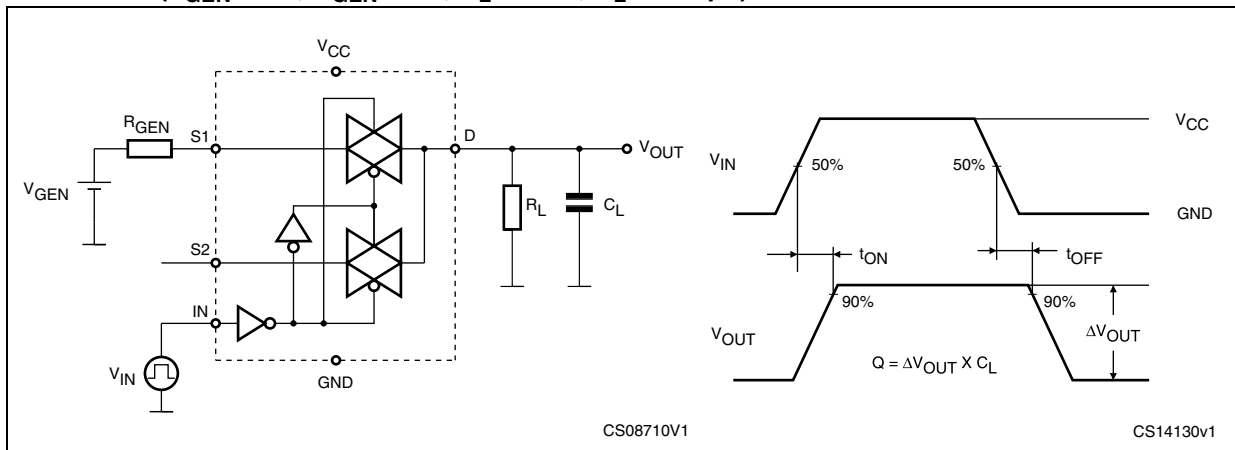
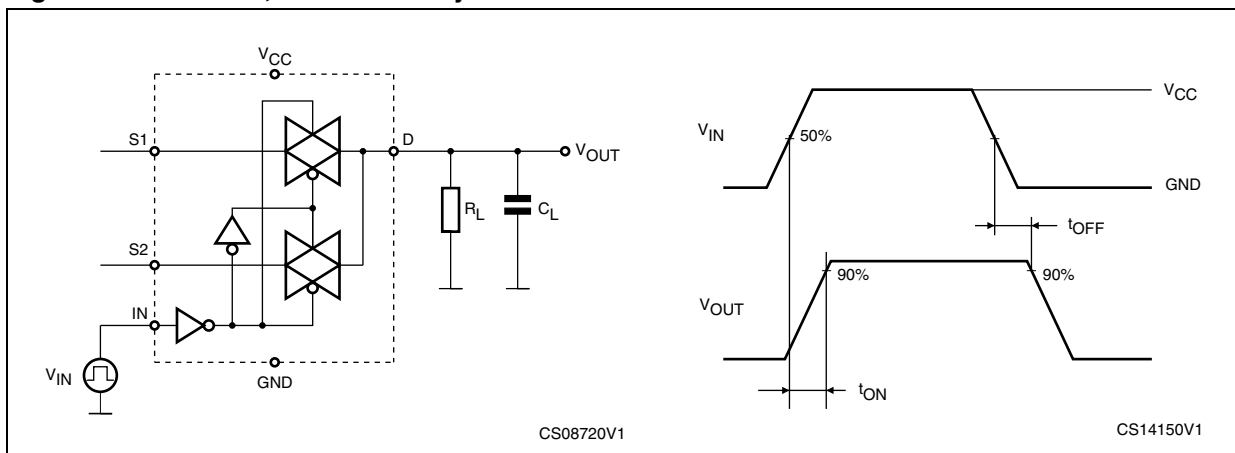

Figure 13. Turn-ON, turn-OFF delay time



6 Package mechanical data

In order to meet environmental requirements, ST offers these devices in different grades of ECOPACK® packages, depending on their level of environmental compliance. ECOPACK® specifications, grade definitions and product status are available at: www.st.com. ECOPACK® is an ST trademark.

Figure 14. Flip Chip6 package outline

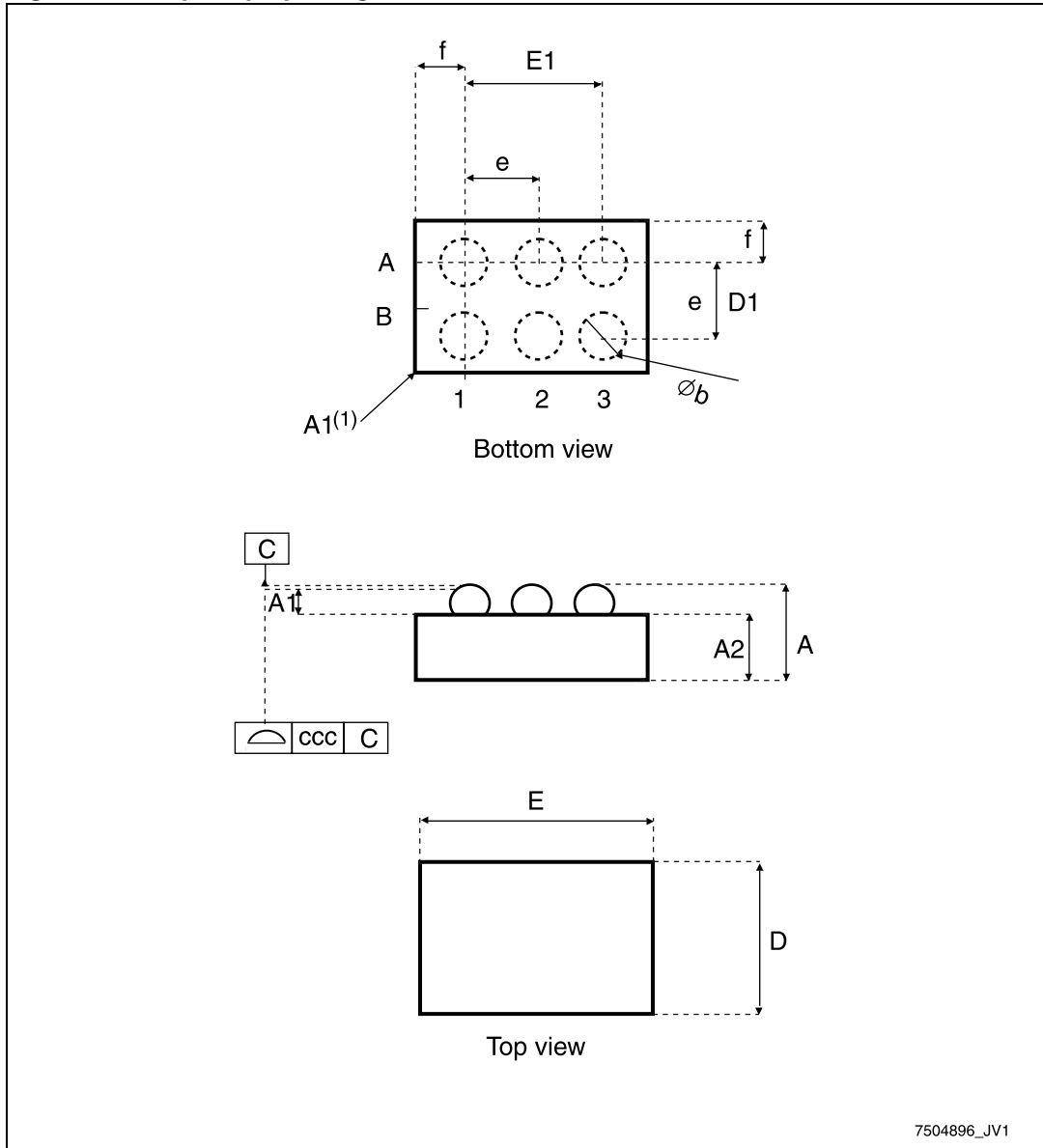

1. The terminal pin 1 on the bumps side is identified by a distinguishing feature (for instance by a circular "clear area" - typically 0.1 mm diameter). The terminal pin 1 on the backside of the product is identified by a distinguishing feature (for instance by a circular "dot" - typically 0.5 mm diameter).
2. Drawing not to scale.

Table 10. Flip Chip6 mechanical data

Symbol	Dimensions (mm.)		
	Min.	Typ.	Max.
A	0.545	0.6	0.655
A1	0.17	0.2	0.23
A2	0.375	0.4	0.425
b	0.23	0.255	0.28
D	0.813	0.828	0.843
D1	0.39	0.4	0.41
E	1.213	1.228	1.243
E1	0.79	0.8	0.81
e	0.36	0.4	0.44
f	0.204	0.214	0.224
ccc		0.05	

Figure 15. Footprint recommendation

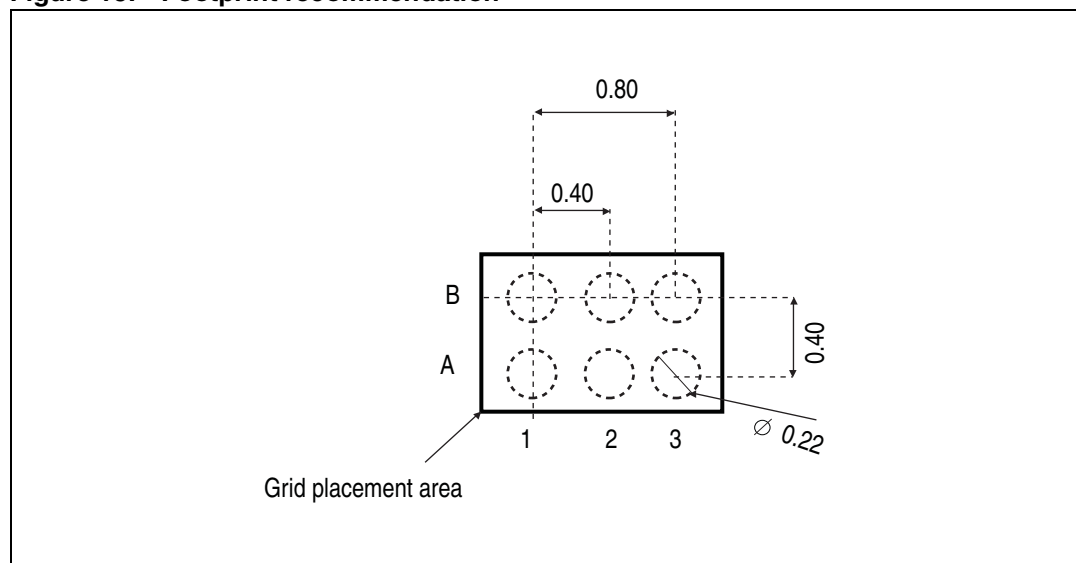

Figure 16. Flip Chip6 marking

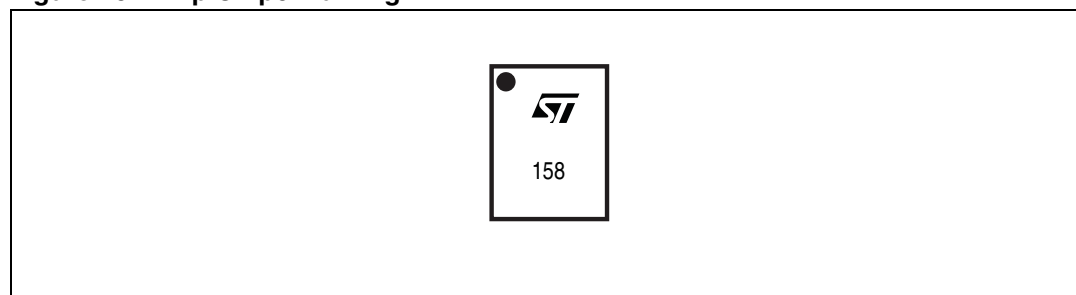
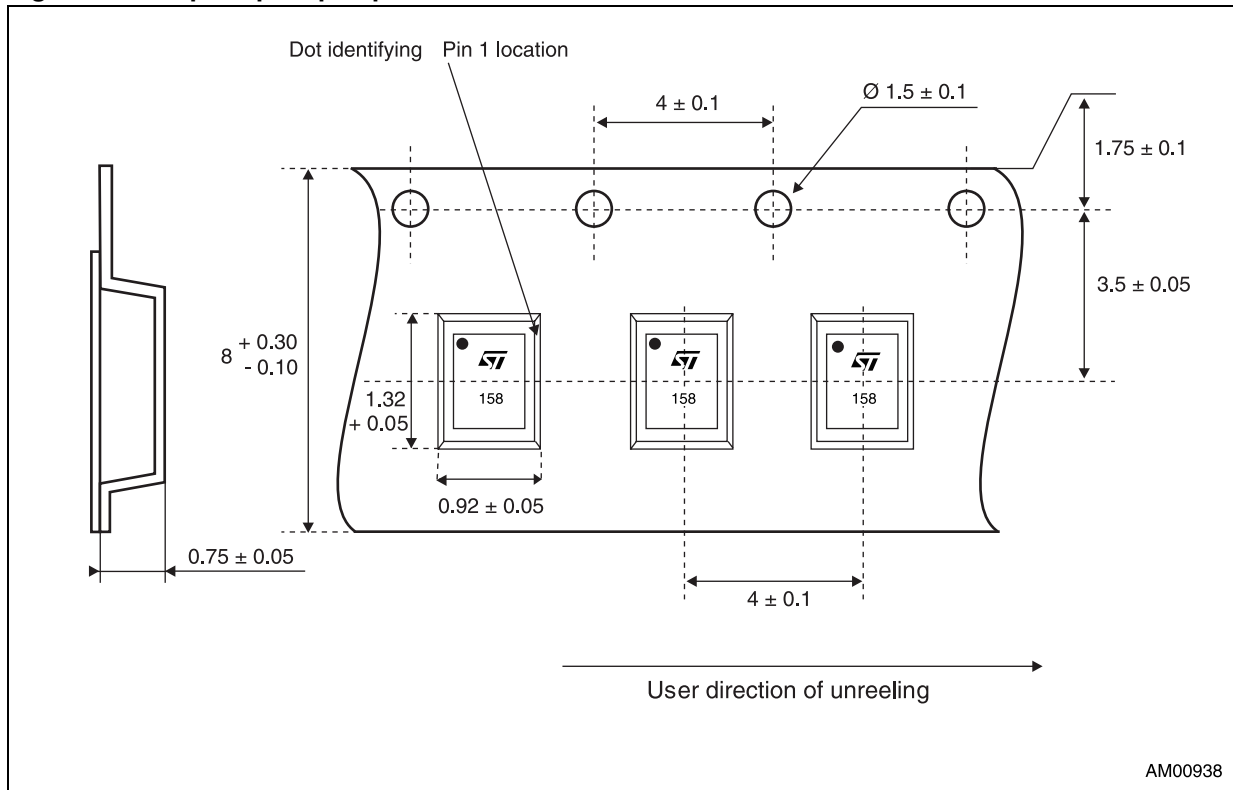
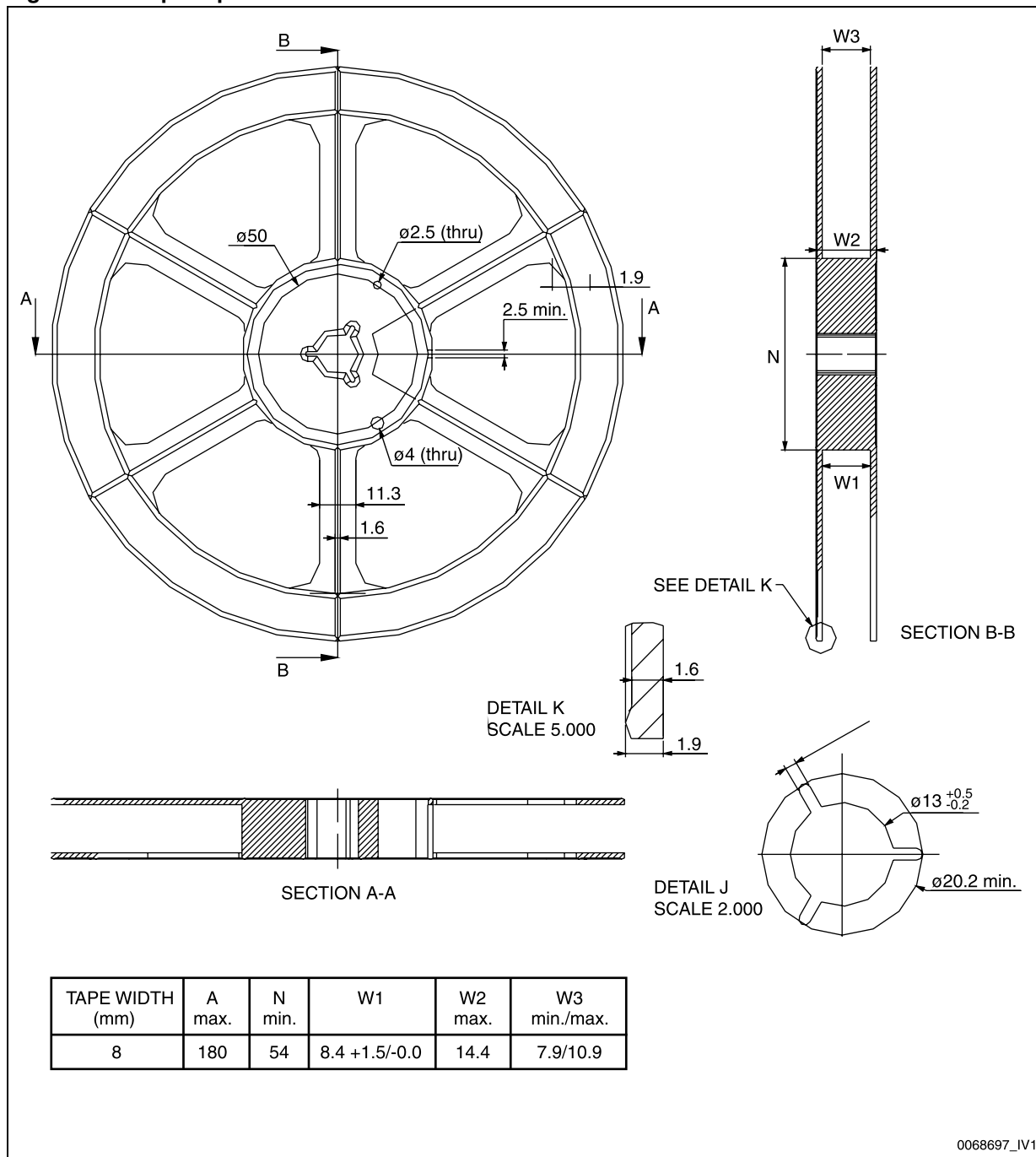

Figure 17. Flip Chip6 tape specification



1. All dimensions in mm.

Figure 18. Flip Chip6 reel information



- Material properties:
 - Antistatic (white or blue).
 - Conductive (black).

7 Die description

Product JSTG4158-CD1

- Wafer size: 203 mm (8 inches)
- Wafer thickness: 725 μm + 20 μm
- Die identification: UP98A.

Die layout

- Design die size (X x Y): 1128 x 728 μm
- Scribe line: 100 x 100 μm
- Stepping die size: 1228 x 828 μm
- Pad opening: 184 x 184 μm
- DI: die identification (at the position shown in [Figure 19](#))
- Pads: pad contact (at the position shown in [Figure 19](#) and [Table 11](#)).

Figure 19. JSTG4158-CD1 die plot

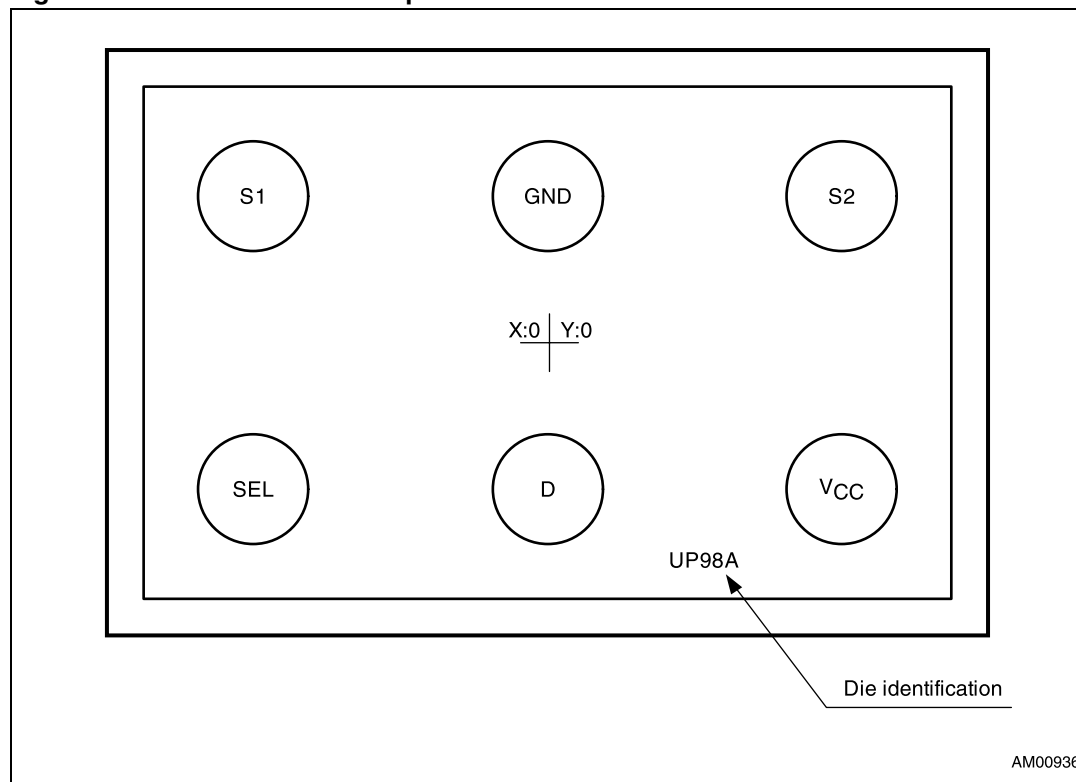

Refer to [Table 11](#) for the pad locations.

Table 11. Pad information

Pad function	X (μm)	Y(μm)
S1	-400	200
GND	0	200
S2	400	200
V _{CC}	400	-200
D	0	-200
SEL	-400	-200

Pad locations are measured relative to the die center (where X and Y are the horizontal and vertical axis, respectively, measured in μm). Refer to [Figure 19](#).

8 Revision history

Table 12. Document revision history

Date	Revision	Changes
12-Nov-2007	1	Initial release
24-Apr-2012	2	Added wafer JSTG4158-CD1, Section 7: Die description , updated Table 1 , Section 2: Maximum rating , ECOPACK [®] , Figure 17 , Figure 18 and Disclaimer, minor text corrections throughout document.

Please Read Carefully:

Information in this document is provided solely in connection with ST products. STMicroelectronics NV and its subsidiaries ("ST") reserve the right to make changes, corrections, modifications or improvements, to this document, and the products and services described herein at any time, without notice.

All ST products are sold pursuant to ST's terms and conditions of sale.

Purchasers are solely responsible for the choice, selection and use of the ST products and services described herein, and ST assumes no liability whatsoever relating to the choice, selection or use of the ST products and services described herein.

No license, express or implied, by estoppel or otherwise, to any intellectual property rights is granted under this document. If any part of this document refers to any third party products or services it shall not be deemed a license grant by ST for the use of such third party products or services, or any intellectual property contained therein or considered as a warranty covering the use in any manner whatsoever of such third party products or services or any intellectual property contained therein.

UNLESS OTHERWISE SET FORTH IN ST'S TERMS AND CONDITIONS OF SALE ST DISCLAIMS ANY EXPRESS OR IMPLIED WARRANTY WITH RESPECT TO THE USE AND/OR SALE OF ST PRODUCTS INCLUDING WITHOUT LIMITATION IMPLIED WARRANTIES OF MERCHANTABILITY, FITNESS FOR A PARTICULAR PURPOSE (AND THEIR EQUIVALENTS UNDER THE LAWS OF ANY JURISDICTION), OR INFRINGEMENT OF ANY PATENT, COPYRIGHT OR OTHER INTELLECTUAL PROPERTY RIGHT.

UNLESS EXPRESSLY APPROVED IN WRITING BY TWO AUTHORIZED ST REPRESENTATIVES, ST PRODUCTS ARE NOT RECOMMENDED, AUTHORIZED OR WARRANTED FOR USE IN MILITARY, AIR CRAFT, SPACE, LIFE SAVING, OR LIFE SUSTAINING APPLICATIONS, NOR IN PRODUCTS OR SYSTEMS WHERE FAILURE OR MALFUNCTION MAY RESULT IN PERSONAL INJURY, DEATH, OR SEVERE PROPERTY OR ENVIRONMENTAL DAMAGE. ST PRODUCTS WHICH ARE NOT SPECIFIED AS "AUTOMOTIVE GRADE" MAY ONLY BE USED IN AUTOMOTIVE APPLICATIONS AT USER'S OWN RISK.

Resale of ST products with provisions different from the statements and/or technical features set forth in this document shall immediately void any warranty granted by ST for the ST product or service described herein and shall not create or extend in any manner whatsoever, any liability of ST.

ST and the ST logo are trademarks or registered trademarks of ST in various countries.

Information in this document supersedes and replaces all information previously supplied.

The ST logo is a registered trademark of STMicroelectronics. All other names are the property of their respective owners.

© 2012 STMicroelectronics - All rights reserved

STMicroelectronics group of companies

Australia - Belgium - Brazil - Canada - China - Czech Republic - Finland - France - Germany - Hong Kong - India - Israel - Italy - Japan - Malaysia - Malta - Morocco - Philippines - Singapore - Spain - Sweden - Switzerland - United Kingdom - United States of America

www.st.com