



ST1G3234B

1-bit dual supply bus buffer level translator with A-side series resistor

Features

- High speed: $t_{PD} = 4.0$ ns (max.) at $T_A = 85$ °C
 $V_{CCB} = 1.65$ V; $V_{CCA} = 3.0$ V
- Low power dissipation:
 $I_{CCA} = I_{CCB} = 5$ μ A (max.) at $T_A = 85$ °C
- Symmetrical output impedance:
 $I_{OHA} = I_{OLA} = 10$ mA min at
 $V_{CCA} = 2.75$ V; $V_{CCB} = 1.4$ to 3.6 V
 $I_{OHA} = I_{OLA} = 6$ mA min. at
 $V_{CCA} = 2.3$ V; $V_{CCB} = 1.4$ to 3.6 V
- Balanced propagation delays:
 $t_{PLH} \cong t_{PHL}$
- Power-down protection on inputs and outputs
- 26 Ω series resistor on A-side outputs
- Operating voltage range:
 - V_{CCA} (opr.) = 1.4 to 3.6 V
 - V_{CCB} (opr.) = 1.4 to 3.6 V
- Allows partial power-down when $V_{CCA} = 0$,
device consumes very low quiescent current
- Max data rates:
 - 380 Mbps (1.8 to 3.3 V translation)
 - 260 Mbps (<1.8 to 3.3 V translation)
 - 260 Mbps (translates to 2.5 V)
 - 210 Mbps (translates to 1.5 V)
- Latch-up performance exceeds 500 mA
(JESD 17)
- ESD performance:
HBM > 2000 V (MIL STD 883 method 3015);
MM > 200 V
- RoHS compliant to Flip-Chip package

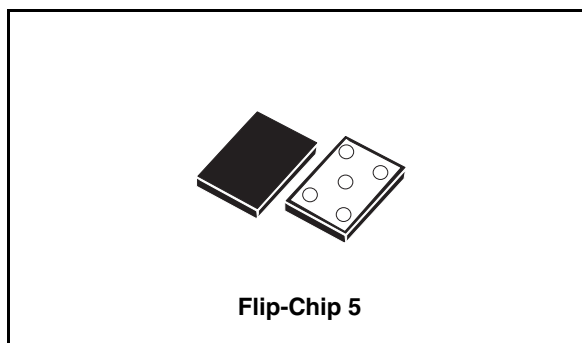

Description

The ST1G3234B is a dual supply low voltage CMOS 1-bit bus buffer level translator fabricated with sub-micron silicon gate and five-layer metal wiring C²MOS technology. Designed for use as an interface between a 3.3 V bus and a 2.5 V or 1.8 V bus in a mixed 3.3 V/ 1.8 V, 3.3 V/ 2.5 V, 1.8 V/ 1.4 V and 2.5 V/ 1.8 V supply systems, it achieves high speed operation while maintaining the CMOS low power dissipation.

The ST1G3234B is intended for one-way asynchronous communication between data buses. The input and output power-down protections disable the device when both power supply are down, so that the buses are effectively isolated.

The input tolerant buffers allow to translate V_{CCB} compatible signals and greater signals than V_{CCB} up/down to V_{CCA} . All inputs are equipped with protection circuits against static discharge, giving them ESD immunity and transient excess voltage.

The ST1G3234B is $V_{CCA} = 0$ V tolerant, achieving very low current consumption when the V_{CCA} is grounded.

Table 1. Device summary

Order code	Package	Comments
ST1G3234BBJR	Flip-Chip 5	4000 parts per reel

Contents

1	Pin settings	3
	1.1 Pin connection	3
	1.2 Pin description	3
2	Device summary	4
3	Maximum rating	5
	3.1 Recommended operating conditions	6
4	Electrical characteristics	7
5	Test circuit	10
6	Waveforms	11
7	Package mechanical data	12
8	Revision history	16

1 Pin settings

1.1 Pin connection

Figure 1. Pin connection (top through view)

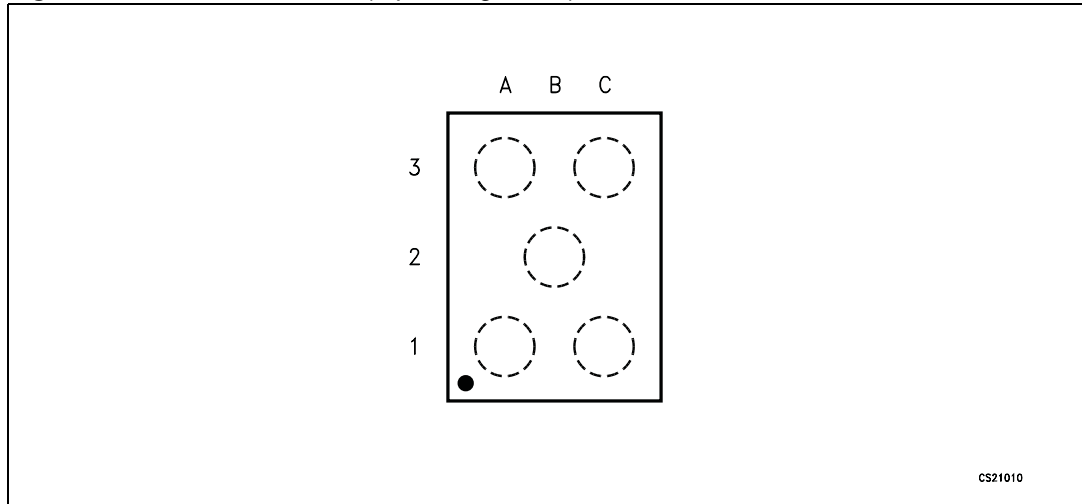

1.2 Pin description

Table 2. Pin description

Pin number	Symbol	Name and function
A1	A1	Data output (V_{CCA} referred)
C1	B1	Data input (V_{CCB} referred)
B2	GND	Ground (0V)
A3	V_{CCA}	Positive supply voltage
C3	V_{CCB}	Positive supply voltage

2 Device summary

Figure 2. Input equivalent circuit

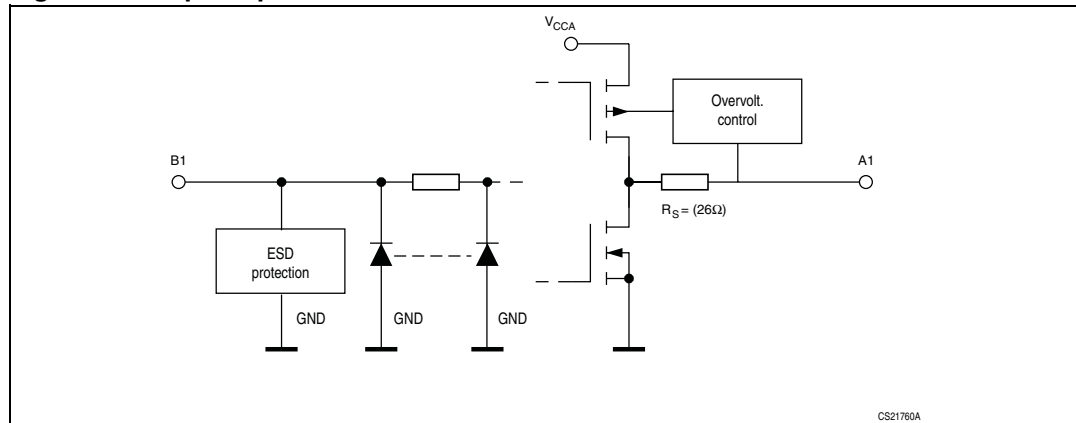

Figure 3. Logic diagram

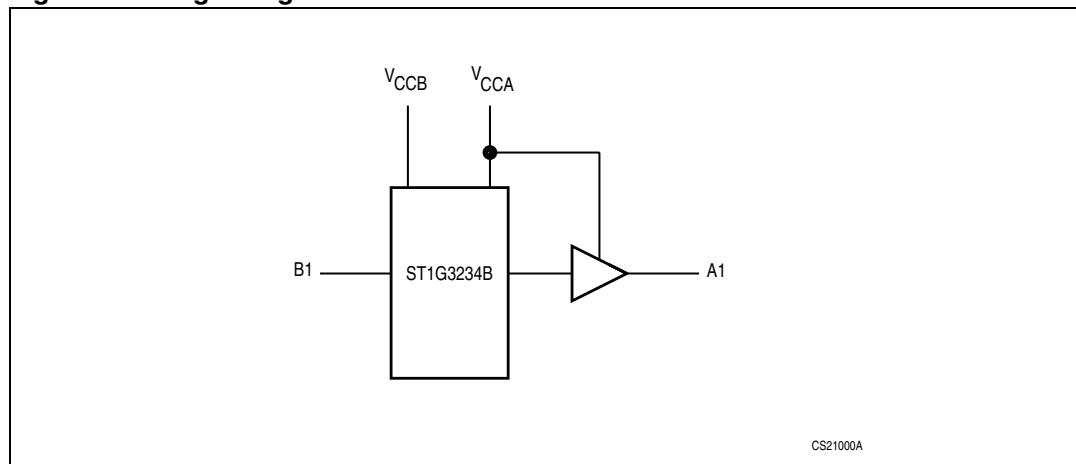

Table 3. Truth table

Inputs B1 (V_{CCB} referred)	Outputs A1 (V_{CCA} referred)
L	L
H	H

3 Maximum rating

Stressing the device above the rating listed in the “Absolute maximum ratings” table may cause permanent damage to the device. These are stress ratings only and operation of the device at these or any other conditions above those indicated in the Operating sections of this specification is not implied. Exposure to absolute maximum rating conditions for extended periods may affect device reliability. Refer also to the STMicroelectronics SURE Program and other relevant quality documents.

Table 4. Absolute maximum ratings

Symbol	Parameter	Value	Unit
V_{CCA}	Output supply voltage	-0.5 to +4.6	V
V_{CCB}	Input supply voltage	-0.5 to + 4.6	V
V_{OA}	DC output voltage (power down mode: $V_{CCA}=V_{CCB}=Gnd$)	-0.5 to +4.6	V
V_{IB}	DC input voltage (power down mode: $V_{CCA}=V_{CCB}=Gnd$)	-0.5 to +4.6	V
V_{OA}	DC output voltage	-0.5 to $V_{CCA} + 0.5$	V
V_{IB}	DC input voltage	-0.5 to + 4.6	V
I_{IK}	DC input diode current	-20	mA
I_{OK}	DC output diode current	-50	mA
I_{OA}	DC output current	± 50	mA
I_{CCA}	DC V_{CCA} or ground current	± 100	mA
I_{CCB}	DC V_{CCB} or ground current	± 100	mA
P_d	Power dissipation	200	mW
T_{stg}	Storage temperature	-65 to +150	°C
T_L	Lead temperature (10 sec)	260	°C

3.1 Recommended operating conditions

Table 5. Recommended operating conditions

Symbol	Parameter		Value	Unit
V_{CCA}	Supply voltage		1.4 to 3.6	V
V_{CCB}	Supply voltage		1.4 to 3.6	V
V_{IB}	Input voltage (B1)		0 to V_{CCB}	V
V_{OA}	Output voltage (A1)		0 to V_{CCA}	V
T_{op}	Operating temperature		-40 to 85	°C
dt/dv	Input rise and fall time	$V_{CCB} = 3.0$ to 3.6 V	0 to 10	ns/V
		$V_{CCB} = 2.3$ to 2.7 V	0 to 20	ns/V
		$V_{CCB} = 1.2$ to 1.95 V	0 to 100	ns/V

4 Electrical characteristics

Table 6. DC specification

Symbol	Parameter	Test condition			Value				Unit
		V_{CCB} (V) ⁽¹⁾	V_{CCA} (V) ⁽¹⁾		$T_A = 25\text{ }^\circ\text{C}$		-40 to 85 °C		
					Min	Max	Min	Max	
V_{IHB}	High level input voltage	1.4	1.4 to 3.6		0.65 V_{CCB}		0.65 V_{CCB}		V
		1.8		0.65 V_{CCB}		0.65 V_{CCB}			
		2.5		1.6		1.6			
		3.3		2.0		2.0			
V_{ILB}	Low level input voltage	1.4	1.4 to 3.6			0.35 V_{CCB}		0.35 V_{CCB}	V
		1.8			0.35 V_{CCB}		0.35 V_{CCB}		
		2.5			0.7		0.7		
		3.3			0.8		0.8		
V_{OHA}	High level output voltage	1.4 to 3.6	1.4	$I_O = -100\text{ }\mu\text{A}$	1.2		1.2		V
			2.75	$I_O = -10\text{ mA}$	2.2		2.2		
			2.3	$I_O = -6\text{ mA}$	1.8		1.8		
			1.65	$I_O = -2\text{ mA}$	1.4		1.4		
			1.4	$I_O = -1\text{ mA}$	1.1		1.1		
V_{OLA}	Low level output voltage	1.4 to 3.6	1.4	$I_O = -100\text{ }\mu\text{A}$		0.20		0.20	V
			2.75	$I_O = 1\text{ mA}$		0.40		0.40	
			2.75	$I_O = 10\text{ mA}$		0.55		0.55	
			2.3	$I_O = 6\text{ mA}$		0.40		0.40	
			1.65	$I_O = 2\text{ mA}$		0.25		0.25	
			1.4	$I_O = 1\text{ mA}$		0.20		0.20	
I_{IB}	Input leakage current	2.7	3.6	$V_{IB} = V_{CCB}$ or GND		± 0.5		± 5	μA
		1.4	2.7	$V_{IB} = 3.6\text{ V}$ or GND		± 0.5		± 5	μA
I_{OFF}	Power OFF leakage current	0	0	$V_{IB} = \text{GND to } 3.6\text{ V}$ $V_{OA} = \text{GND to } 3.6\text{ V}$		± 1.0		± 10	μA

Table 6. DC specification (continued)

Symbol	Parameter	Test condition			Value				Unit
		V _{CCB} (V) ⁽¹⁾	V _{CCA} (V) ⁽¹⁾	V _{IB} = V _{CCB} or GND	T _A = 25 °C		-40 to 85 °C		
					Min	Max	Min	Max	
I _{CCB}	Quiescent supply current	1.4 to 3.6	1.4 to 3.6	V _{IB} = V _{CCB} or GND	0.5		5	μA	
		1.4 to 3.6	0						
I _{CCA}	Quiescent supply current	1.4 to 3.6	1.4 to 3.6	V _{IB} = V _{CCB} or GND	0.5		5	μA	

1. V_{CC} range = 1.8 ± 0.15 V; 2.5 ± 0.2 V; 3.3 ± 0.3 V

Table 7. AC electrical characteristics

Symbol	Parameter	Test condition			Value		Unit
		V _{CCB} (V)	V _{CCA} (V)	C _L	-40 to 85 °C		
					Min	Max	
t _{PLH} t _{PHL}	Propagation delay time B1 to A1	2.3 to 3.6	1.4	C _L = 10 pF	2.0	5.0	ns
		1.4 to 1.95	1.4		2.0	5.0	
		2.3 to 3.6	1.65 to 1.95		2.0	4.5	
		1.4 to 1.95	1.65 to 1.95		2.0	4.8	
		1.4 to 1.95	2.3 to 2.7		2.0	3.5	
		1.4 to 1.95	3.0 to 3.6		2.0	3.5	
		2.3 to 2.7	3.0 to 3.6		1.0	3.0	
t _{PLH} t _{PHL}	Propagation delay time B1 to A1	2.3 to 3.6	1.4	C _L = 30 pF R _L = 500 Ω	2.0	5.5	ns
		1.4 to 1.95	1.4		2.0	5.5	
		2.3 to 3.6	1.65 to 1.95		2.0	5.0	
		1.4 to 1.95	1.65 to 1.95		2.0	5.2	
		1.4 to 1.95	2.3 to 2.7		2.0	4.0	
		1.4 to 1.95	3.0 to 3.6		2.0	4.0	
		2.3 to 2.7	3.0 to 3.6		1.0	3.5	

Table 8. Capacitance characteristics

Symbol	Parameter	Test condition			Value					Unit
		V _{CCB} (V)	V _{CCA} (V)		T _A = 25 °C			-40 to 85 °C		
					Min	Typ	Max	Min	Max	
C _{INB}	Input capacitance	open	open			5				pF
C _O	Output capacitance	2.5	3.3			6				pF
C _{PD}	Power dissipation capacitance	2.5	3.3	f = 10 MHz		27				pF
		1.8	3.3			27				
		1.4	2.5			23				
		1.4	1.8			20				
		3.3	1.8			27				

Note: 1 C_{PD} is defined as the value of the device's internal equivalent capacitance which is calculated from the operating current consumption without load. (Refer to Test Circuit). Average current can be obtained by the following equation: $I_{CC(opr)} = C_{PD} \times V_{CC} \times f_{IN} + I_{CC}/4$ (per circuit)

5 Test circuit

Figure 4. Test circuit

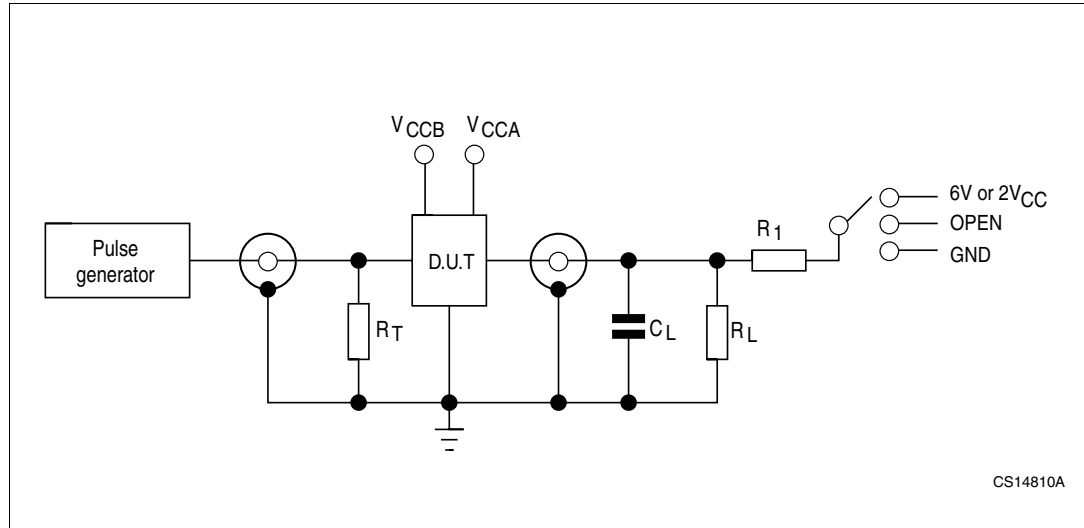

Table 9. Test circuit

Test	Switch
t_{PLH} , t_{PHL}	Open

$C_L = 10/30$ pF or equivalent (includes jig and probe capacitance)

$R_L = R_1 = 500 \Omega$ or equivalent

$R_T = Z_{OUT}$ of pulse generator (typically 50Ω)

6 Waveforms

Table 10. Waveform symbol value

Symbol	V _{CC}		
	3.0 to 3.6 V	2.3 to 2.7 V	1.65 to 1.95 V
V _{IH}	V _{CC}	V _{CC}	V _{CC}
V _M	1.5 V	V _{CC} /2	V _{CC} /2

Figure 5. Waveform - propagation delay (f = 1 MHz; 50 % duty cycle)

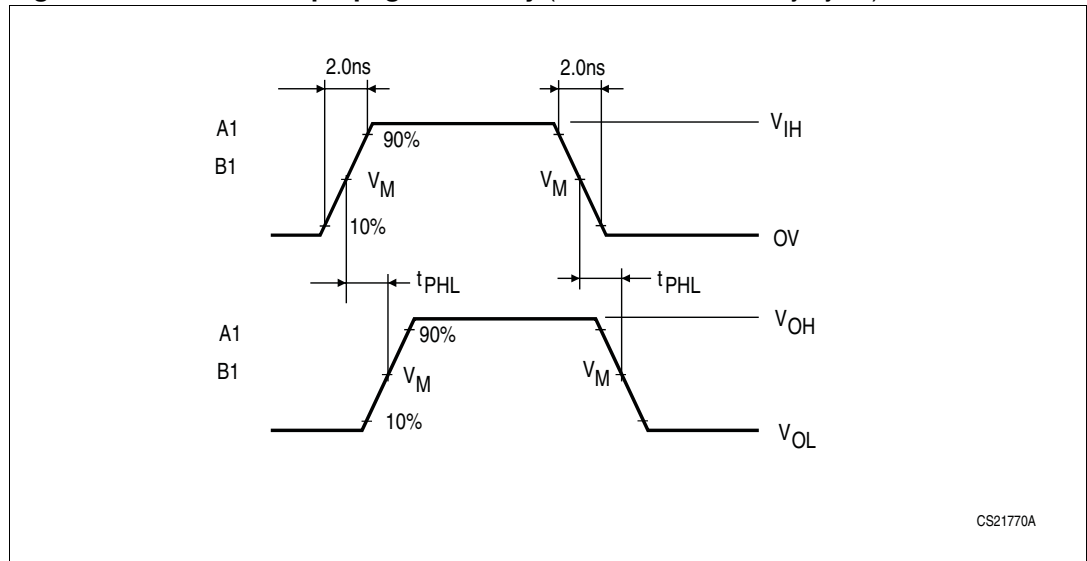

7 Package mechanical data

In order to meet environmental requirements, ST offers these devices in ECOPACK[®] packages. These packages have a Lead-free second level interconnect . The category of second level interconnect is marked on the package and on the inner box label, in compliance with JEDEC Standard JESD97. The maximum ratings related to soldering conditions are also marked on the inner box label. ECOPACK is an ST trademark. ECOPACK specifications are available at: www.st.com.

Figure 6. Marking

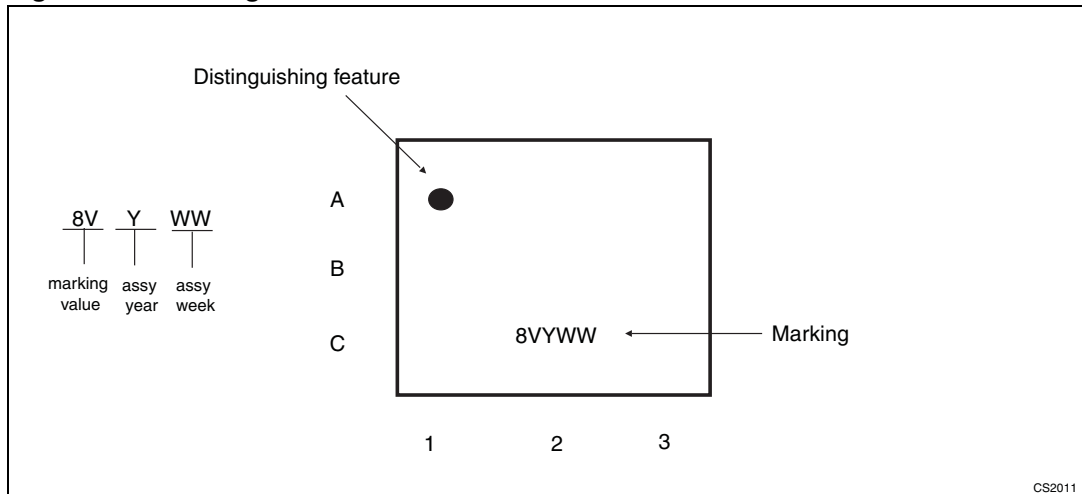

Figure 7. Flip-Chip 5 package outline

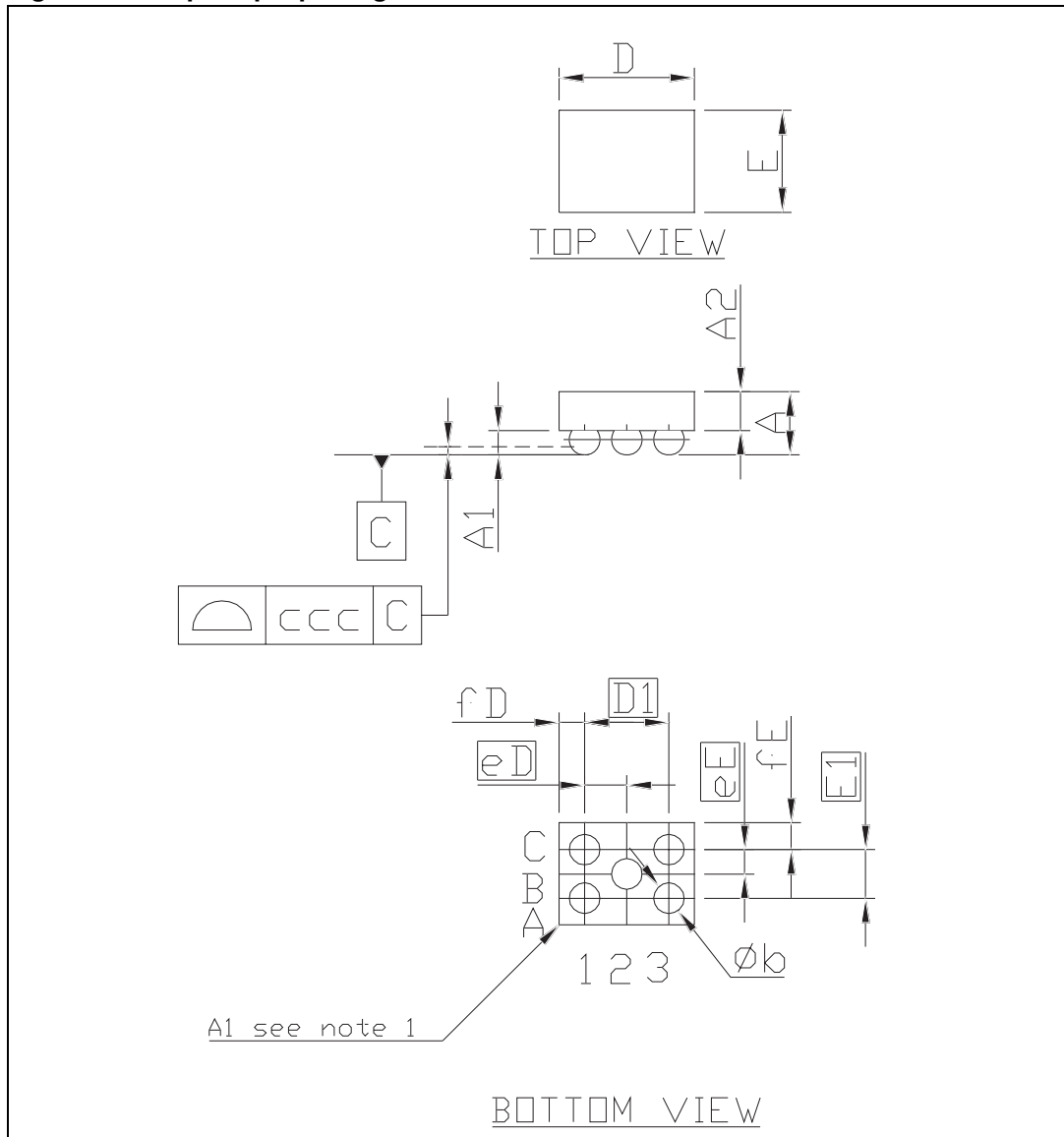
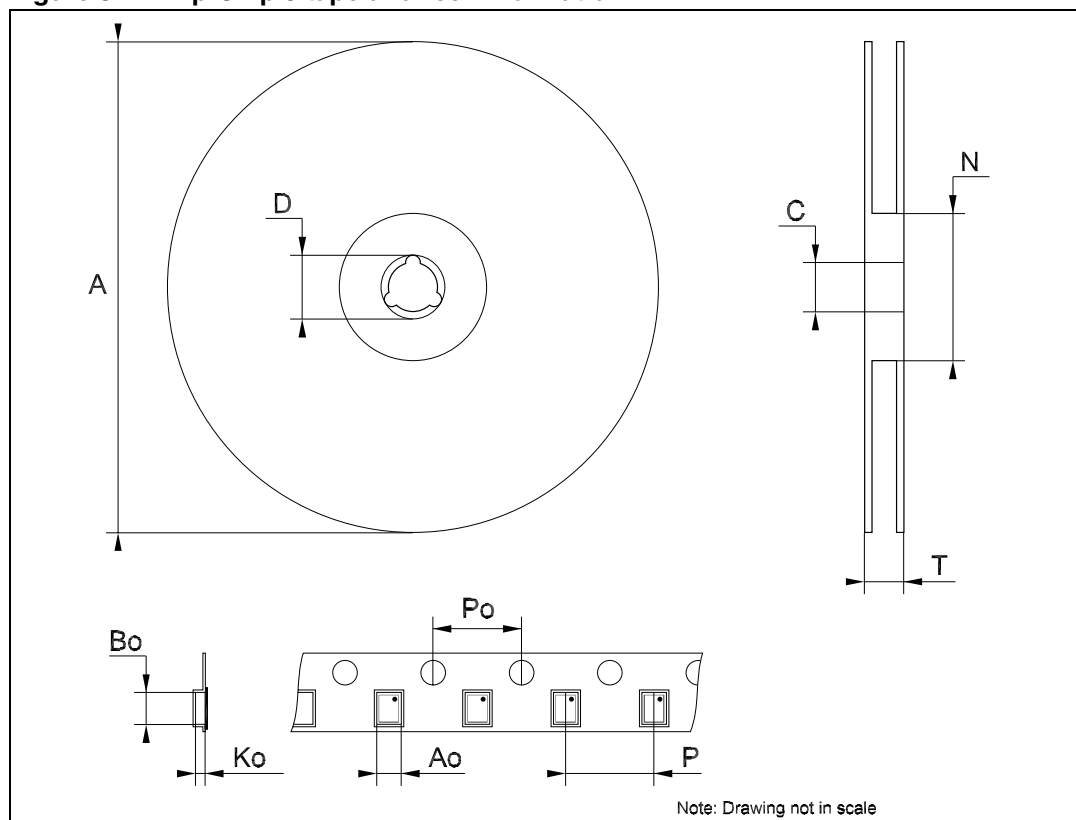

Table 11. Flip-Chip 5 mechanical data

Symbol	millimeters			mils		
	Min	Typ	Max	Min	Typ	Max
A	0.585	0.65	0.714	23.0	25.6	28.1
A1	0.21	0.25	0.29	8.3	9.8	11.4
a2		0.40			15.7	
b	0.265	0.315	0.365	10.4	12.4	14.4
D	1.31	1.36	1.41	51.6	53.5	55.5
D1		9.866			34.1	
E	0.97	1.02	1.07	38.2	40.2	42.1
E1		0.5			19.7	
eD	0.383	0.433	0.483	15.1	17.0	19.0
eE	0.20	0.25	0.30	7.9	9.8	11.8
fD		0.247			9.7	
fE		0.260			10.2	
ccc		0.080			3.1	

Figure 8. Flip-Chip 5 tape and reel information



1. Drawing not to scale.

Table 12. Flip-Chip 5 tape and reel mechanical data

Symbol	millimeters			inches		
	Min	Typ	Max	Min	Typ	Max
A			178			6.926
C	12.8		13.2	0.504		0.519
D	20.2			0.795		
N	49	50	51	1.929	1.969	2.008
T			12.4			0.488
Ao	1.60	1.65	1.70	0.063	0.065	0.067
Bo	1.27	1.32	1.37	0.050	0.052	0.054
Ko	0.76	0.81	0.86	0.030	0.032	0.034
Po	3.9	4	4.1	0.153	0.157	0.161
P	3.9	4	4.1	0.153	0.157	0.161

8 Revision history

Table 13. Document revision history

Date	Revision	Changes
1-Aug-2007	1	Initial release.
3-Dec-2007	2	Changed t_{PD} value from 4.4 ns to 4.0 ns, removed footnote in Table 5: Recommended operating conditions on page 6 , updated V_{OLA} value at $V_{CCA} = 1.4$ V, changed symbol names for quiescent supply current and minor text changes in Table 6: DC specification on page 7 , removed V_X and V_Y waveforms data in Table 10: Waveform symbol value on page 11 , replaced Figure 6: Marking on page 12 and enlarged Figure 7: Flip-Chip 5 package outline on page 13 to improve readability.

Please Read Carefully:

Information in this document is provided solely in connection with ST products. STMicroelectronics NV and its subsidiaries ("ST") reserve the right to make changes, corrections, modifications or improvements, to this document, and the products and services described herein at any time, without notice.

All ST products are sold pursuant to ST's terms and conditions of sale.

Purchasers are solely responsible for the choice, selection and use of the ST products and services described herein, and ST assumes no liability whatsoever relating to the choice, selection or use of the ST products and services described herein.

No license, express or implied, by estoppel or otherwise, to any intellectual property rights is granted under this document. If any part of this document refers to any third party products or services it shall not be deemed a license grant by ST for the use of such third party products or services, or any intellectual property contained therein or considered as a warranty covering the use in any manner whatsoever of such third party products or services or any intellectual property contained therein.

UNLESS OTHERWISE SET FORTH IN ST'S TERMS AND CONDITIONS OF SALE ST DISCLAIMS ANY EXPRESS OR IMPLIED WARRANTY WITH RESPECT TO THE USE AND/OR SALE OF ST PRODUCTS INCLUDING WITHOUT LIMITATION IMPLIED WARRANTIES OF MERCHANTABILITY, FITNESS FOR A PARTICULAR PURPOSE (AND THEIR EQUIVALENTS UNDER THE LAWS OF ANY JURISDICTION), OR INFRINGEMENT OF ANY PATENT, COPYRIGHT OR OTHER INTELLECTUAL PROPERTY RIGHT.

UNLESS EXPRESSLY APPROVED IN WRITING BY AN AUTHORIZED ST REPRESENTATIVE, ST PRODUCTS ARE NOT RECOMMENDED, AUTHORIZED OR WARRANTED FOR USE IN MILITARY, AIR CRAFT, SPACE, LIFE SAVING, OR LIFE SUSTAINING APPLICATIONS, NOR IN PRODUCTS OR SYSTEMS WHERE FAILURE OR MALFUNCTION MAY RESULT IN PERSONAL INJURY, DEATH, OR SEVERE PROPERTY OR ENVIRONMENTAL DAMAGE. ST PRODUCTS WHICH ARE NOT SPECIFIED AS "AUTOMOTIVE GRADE" MAY ONLY BE USED IN AUTOMOTIVE APPLICATIONS AT USER'S OWN RISK.

Resale of ST products with provisions different from the statements and/or technical features set forth in this document shall immediately void any warranty granted by ST for the ST product or service described herein and shall not create or extend in any manner whatsoever, any liability of ST.

ST and the ST logo are trademarks or registered trademarks of ST in various countries.

Information in this document supersedes and replaces all information previously supplied.

The ST logo is a registered trademark of STMicroelectronics. All other names are the property of their respective owners.

© 2007 STMicroelectronics - All rights reserved

STMicroelectronics group of companies

Australia - Belgium - Brazil - Canada - China - Czech Republic - Finland - France - Germany - Hong Kong - India - Israel - Italy - Japan - Malaysia - Malta - Morocco - Singapore - Spain - Sweden - Switzerland - United Kingdom - United States of America

www.st.com