



ST6G3238BE

Dual supply level translator for SD/ MINISD/ T-FLASH With $\pm 8\text{KV}$ contact discharge ESD protection

Features

- High speed: $t_{PD} = 4.4\text{ns}$ (Typ.) at $T_A = 85^\circ\text{C}$
 $V_{CCB} = 2.7\text{V}$ $V_{CCA} = 1.8\text{V}$
- Low power dissipation:
 $I_{CCA} = I_{CCB} = 5\mu\text{A}$ (Max.) at $T_A = 85^\circ\text{C}$
- Balanced propagation delays: $T_{PLH} \approx T_{PHL}$
- Power down protection on inputs and outputs
- 26Ω series resistor on A-Side
- EMI filter on B side
- Integrated pull-up and pull-down resistor on B side
- Operating voltage range:
 - V_{CCA} (Opr) = 1.4V to V_{CCB}
 - V_{CCB} (Opr) = 1.4V to 3.6V
- Latch-up performance exceeds 500mA (JESD17)
- ESD protection for card side (B port, CD and WP pins) $\pm 8\text{kV}$, IEC 61000-4-2 ESD or contact discharge:
HBM $> \pm 15\text{kV}$ (MIL STD 883 method 3015);
- ESD protection for A-port:
HBM $> \pm 2\text{kV}$ (MIL STD 883 method 3015);
- RoHS Compliant for $\mu\text{TFBGA}25$ Package

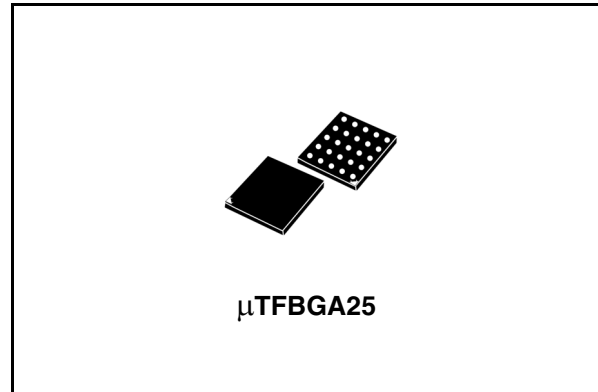

Description

The ST6G3238BE is a dual supply low voltage CMOS Level Translator for SD/ MiniSD/ T-Flash fabricated with sub-micron silicon gate and five-layer metal wiring C²MOS technology. Designed for use as an interface between a 3.3V bus and a 2.5V or 1.8V bus in a mixed 3.3V/1.8V, 3.3V/2.5V and 2.5V/1.8V supply systems, it achieves high speed operation while maintaining the CMOS low power dissipation. The A port is designed to track V_{CCB} . The B port is designed to track V_{CCA} .

This device is intended for two-way asynchronous communication between data buses and the direction of data transmission is determined by CMD-dir/ DATA0-dir/ DAT123-dir inputs. The B-port interfaces with the 3V bus, the A-port with the 2.5V and 1.8V bus.

All inputs are equipped with protection circuits against static discharge, giving them $\pm 2\text{kV}$ (on A-side except CD and WP pins) and $\pm 15\text{kV}$ on (B side, CD and WP pins) ESD immunity and transient excess voltage. See the section on integrated ESD protections and resistors for more information.

Order code

Part Number	Package	Packaging
ST6G3238BE	$\mu\text{TFBGA}25$	Tube
ST6G3238BETBR	$\mu\text{TFBGA}25$	Tape and Reel

Contents

1	Logic diagram	3
2	Pin connection and function	4
	2.1 Pin function	5
3	Summary description	6
4	Maximum rating	7
5	DC and AC parameters	8
6	I/O and test circuit	11
7	Waveforms	12
8	Package mechanical data	13
9	Revision history	16

1 Logic diagram

Figure 1. Block diagram

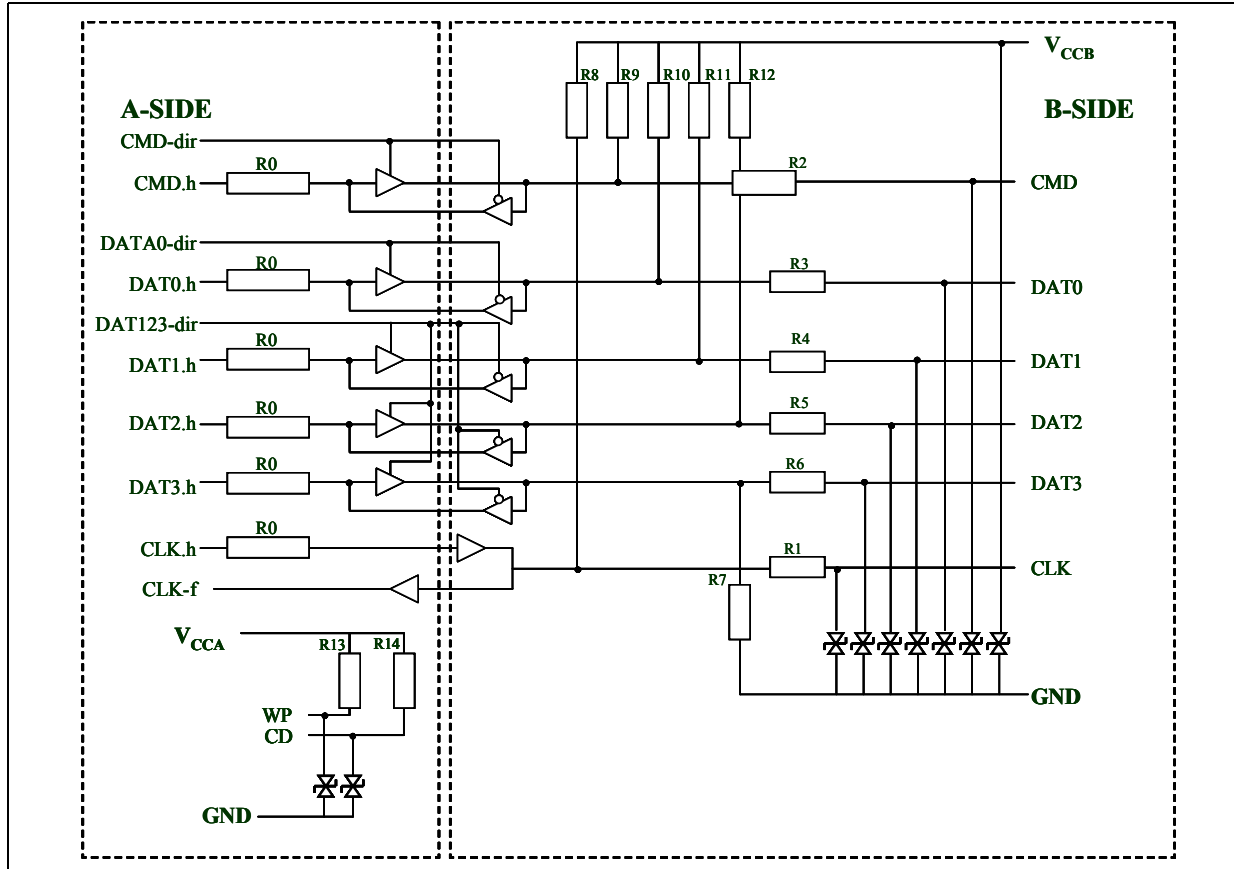

Table 1. Integrated ESD protection and resistor on B-Side

Resistors	Value	Bi-directional Zener diodes	
R1, R2, R3, R4, R5, R6	40Ω	Vbr min.	14V @ 1mA
R0	25Ω	Line capacitance	< 20 pF
Tolerance	±20%		
R10, R11, R12	70kΩ		
R9	15kΩ		
R7	470kΩ		
Tolerance	±30%		

Table 2. Integrated pull-up resistors on WP and CD pins on A-Side

Resistors	Value
R13	100kΩ
R14	100kΩ
Tolerance	±30%

2 Pin connection and function

Figure 2. Pin connection (top through view for μ TFBGA)

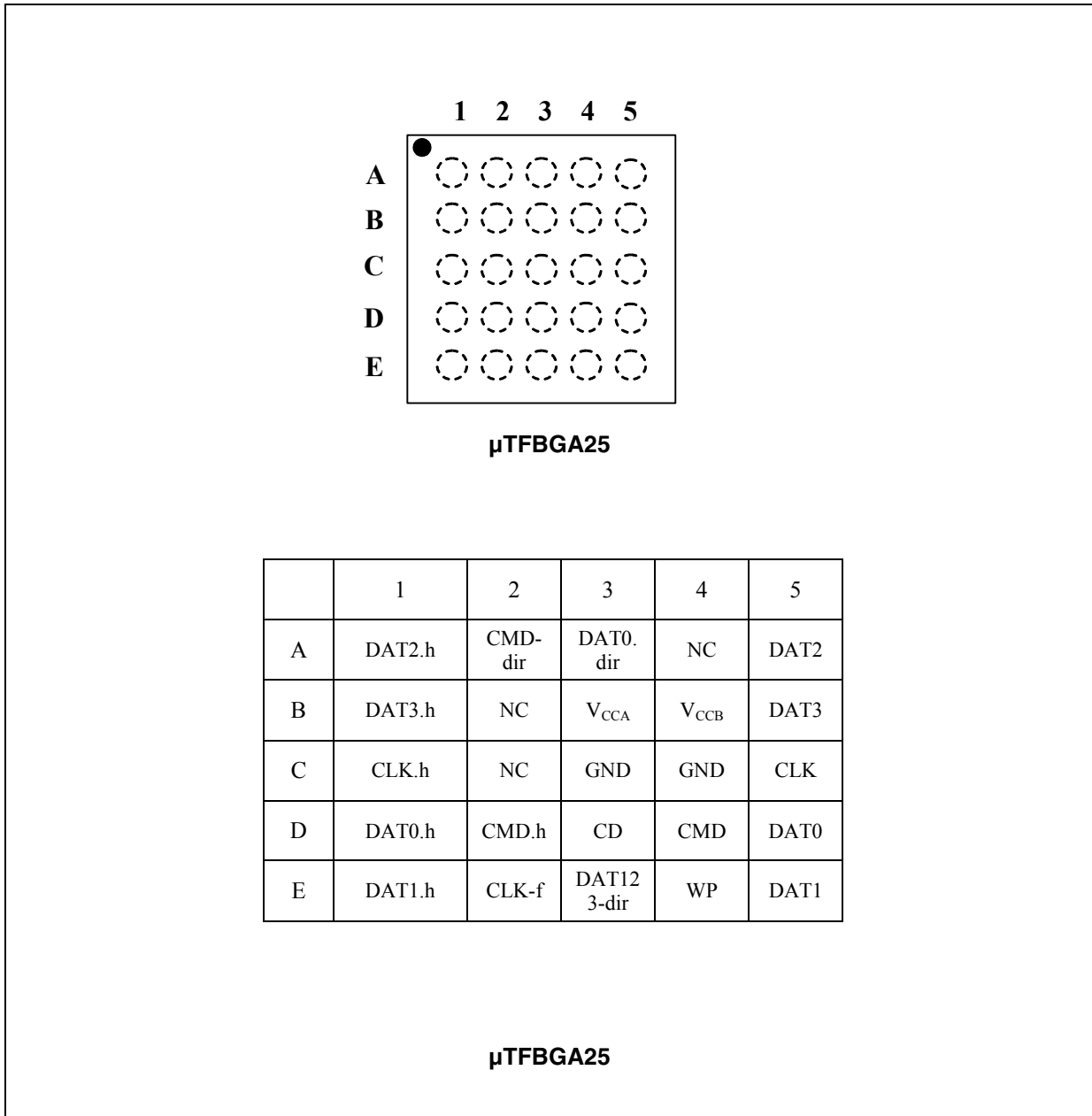

2.1 Pin function

- CMD, Command is a bi-directional line. The host and card drivers are operating in push-pull.
- DAT0-3, Data lines are bi-directional lines. The host and the card drivers are operating in push-pull mode.
- CLK, Clock is a host to card signal. CLK operates in push-pull mode.
- Feedback (return) Clock is feedback clock signal from level shifter to host for controlling delays.
- CD, Card detect, pulls HIGH state of input to V_{CCA} . This pin is protected against ESD up to 8kV contact.
- WP, Write protect, pulls HIGH state of input to V_{CCA} . This pin is protected against ESD up to 8kV contact.

Table 3. Pin description

μ TFBGA Pin N°	Type	Side	Symbol	Name and function
A2	I	A-side	CMD-dir	Command direction HIGH = A to B LOW = B to A
D2	I/O	A-side	CMD.h	A-side Command
D4	I/O	B-Side	CMD	B-side Command
A3	I	A-Side	DAT0-dir	Data Direction HIGH = A to B (write) LOW = B to A (read)
D1	I/O	A-Side	DAT0.h	Data Input / Output
D5	I/O	B-Side	DAT0	Data Input / Output
E3	I	A-Side	DAT123-dir	Data Direction HIGH = A to B (write) LOW = B to A (read)
E1	I/O	A-Side	DAT1.h	Data Input / Output
A1	I/O	A-Side	DAT2.h	Data Input / Output
B1	I/O	A-Side	DAT3.h	Data Input / Output
E5	I/O	B-Side	DAT1	Data Input / Output
A5	I/O	B-Side	DAT2	Data Input / Output
B5	I/O	B-Side	DAT3	Data Input / Output
C1	I	A-Side	CLK.h	Clock Input
C5	O	B-Side	CLK	Clock Output
E2	O	A-Side	CLK-f	Clock Feedback
D3	-	A-Side	CD	Card Detect
E4	-	A-Side	WP	Write Protect
B3	-	A-Side	V_{CCA}	Power supply
B4	-	B-Side	V_{CCB}	Power supply
C3, C4	-	-	GND	Ground (0V)
A4, B2, C2	-	-	NC	No connect

3 Summary description

Table 4. Truth table

Function									Output
CMD-dir	DAT0-dir	DAT123-dir	CMD.h	CMD	DAT0.h	DAT0	DAT1.h DAT2.h DAT3.h	DAT1 DAT2 DAT3	
H	X	X	INPUT	OUTPUT	X	X	X	X	B = A
L	X	X	OUTPUT	INPUT	X	X	X	X	A = B
X	H	X	X	X	INPUT	OUTPUT	X	X	B = A
X	L	X	X	X	OUTPUT	INPUT	X	X	A = B
X	X	H	X	X	X	X	INPUT	OUTPUT	B = A
X	X	L	X	X	X	X	OUTPUT	INPUT	A = B

Note: X = Don't care; Z = High Impedance

4 Maximum rating

Stressing the device above the rating listed in the “Absolute Maximum Ratings” table may cause permanent damage to the device. These are stress ratings only and operation of the device at these or any other conditions above those indicated in the Operating sections of this specification is not implied. Exposure to Absolute Maximum Rating conditions for extended periods may affect device reliability. Refer also to the STMicroelectronics SURE Program and other relevant quality documents.

Table 5. Absolute maximum ratings

Symbol	Parameter	Value	Unit
V_{CCA}	Supply voltage	-0.5 to 4.6	V
V_{CCB}	Supply voltage	-0.5 to 4.6	V
V_I	DC input voltage	-0.5 to 4.6	V
$V_{I/OA}$	DC I/O voltage (output disabled)	-0.5 to 4.6	V
$V_{I/OB}$	DC I/O voltage (output disabled)	-0.5 to 4.6	V
$V_{I/OA}$	DC output voltage	-0.5 to $V_{CCA} + 0.5$	V
$V_{I/OB}$	DC output voltage	-0.5 to $V_{CCB} + 0.5$	V
I_{IK}	DC input diode current	-20	mA
I_{OK}	DC output diode current	-50	mA
I_{OA}	DC output current	± 50	mA
I_{OB}	DC output current	± 50	mA
I_{CCA}	DC V_{CC} or ground current	± 100	mA
I_{CCB}	DC V_{CC} or ground current	± 100	mA
P_D	Power dissipation	400	mW
T_{stg}	Storage temperature	-65 to +150	°C
T_L	Lead temperature (10 sec)	260	°C

Table 6. Recommended operating conditions

Symbol	Parameter	Value	Unit
V_{CCA}	Supply voltage	1.4 to V_{CCB}	V
V_{CCB}	Supply voltage	1.4 to 3.6	V
V_I	Input voltage (CMD-dir/DAT0-dir/DAT123-dir)	0 to V_{CCA}	V
$V_{I/OA}$	I/O voltage	0 to V_{CCA}	V
$V_{I/OB}$	I/O voltage	0 to V_{CCB}	V
T_{op}	Operating temperature	-40 to +85	°C
dt/dv	Input rise and fall time ⁽¹⁾	0 to 10	ns/V

1. V_{IN} from 0.8V to 2.0V at $V_{CC} = 3.0V$

5 DC and AC parameters

Table 7. DC specification

Symbol	Parameter	Test conditions			Value				Unit
		V _{CCA} (V)	V _{CCB} (V)		T _A = 25°C		-40 to 85°C		
					Min.	Max.	Min.	Max.	
V _{IH} (A port)	High level input voltage	1.4-1.95	V _{CCA} to 3.6		0.65V _{CCA}		0.65V _{CCA}		V
		1.95-2.7		1.7		1.7			
		2.7-3.6		2.0		2.0			
V _{IL} (A port)	Low level input voltage	1.4-1.95	V _{CCA} to 3.6			0.35V _{CCA}		0.35V _{CCA}	V
		1.95-2.7			0.7		0.7		
		2.7-3.6			0.8		0.8		
V _{IH} (B port)	High level input voltage	1.4 to V _{CCB}	1.4-1.95		0.65V _{CCB}		0.65V _{CCB}		V
			1.95-2.7	1.7		1.7			
			2.7-3.6	2.0		2.0			
V _{IL} (B port)	Low level input voltage	1.4 to V _{CCB}	1.4-1.95			0.35V _{CCB}		0.35V _{CCB}	V
			1.95-2.7		0.7		0.7		
			2.7-3.6		0.8		0.8		
V _{OH} (A port)	High level output voltage	1.4-3.6	1.4-3.6	I _{OH} = -100µA	V _{CCA} -0.1		V _{CCA} -0.1		V
		1.4	1.4	I _{OH} = -1 mA	1.20		1.20		
		1.65	1.65	I _{OH} = -2 mA	1.40		1.40		
		2.3	2.3	I _{OH} = -4 mA	1.90		1.90		
		3	3	I _{OH} = -8 mA	2.45		2.45		
V _{OL} (A port)	Low level output voltage	1.4-3.6	1.4-3.6	I _{OL} = 100µA		0.10		0.10	V
		1.4	1.4	I _{OL} = 1 mA		0.20		0.20	
		1.65	1.65	I _{OL} = 2 mA		0.25		0.25	
		2.3	2.3	I _{OL} = 4 mA		0.40		0.40	
		3	3	I _{OL} = 8 mA		0.55		0.55	
V _{OH} (B port)	High level output voltage	1.4-3.6	1.4-3.6	I _{OH} = -100µA	V _{CCA} -0.2		V _{CCA} -0.2		V
		1.4	1.4	I _{OH} = -1 mA	1.05		1.05		
		1.65	1.65	I _{OH} = -4 mA	1.20		1.20		
		2.3	2.3	I _{OH} = -6 mA	1.75		1.75		
		3	3	I _{OH} = -8 mA	2.30		2.30		

Note: All A-port I/Os and control inputs are powered by V_{CCA}. All B-port I/Os are powered by V_{CCB}.

Table 7. DC specification (continued)

Symbol	Parameter	Test conditions			Value				Unit
		V _{CCA} (V)	V _{CCB} (V)		T _A = 25°C		-40 to 85°C		
					Min.	Max.	Min.	Max.	
V _{OL} (B port)	Low level output voltage	1.4-3.6	1.4-3.6	I _{OL} = 100µA		0.20		0.20	V
		1.4	1.4	I _{OL} = 1 mA		0.35		0.35	
		1.65	1.65	I _{OL} = 4 mA		0.45		0.45	
		2.3	2.3	I _{OL} = 6 mA		0.55		0.55	
		3	3	I _{OL} = 8 mA		0.70		0.70	
I _{IA}	Input leakage current for A-side	1.8	2.9	V _{IA} =V _{CC} or GND DIR=HIGH V _{CD} =V _{WP} =V _{CCA}		±0.5		±5	µA
I _{IB}	Input leakage current for B-side	1.8	2.9	V _{CLK,h} =V _{CCA} V _{CMD} =V _{CCB} V _{DAT0,DAT1,DAT2} =V _{CCB} V _{DAT3} =GND DIR=LOW V _{CD} =V _{WP} =V _{CCA}		±0.5		±5	µA
I _{CCA}	Quiescent supply current for A-side	1.4	1.4 - 3.6	V _{IA} =V _{CCA} or GND V _{CD} =V _{WP} =V _{CCA} DIR = A to B		0.5		5	µA
		1.4 - 3.6	0						
		1.4 - 3.6	3.6						
I _{CCB}	Quiescent supply current for B-side	1.4	1.4 - 3.6	V _{CLK,h} =V _{CCA} or GND V _{IB} =OPEN DIR = B to A V _{CD} =V _{WP} =V _{CCA}		0.5		5	µA
		1.4 - 3.6	3.6						
I _{WP}	WP pin input leakage current	1.8	3.0	V _{IA} =V _{CCA} or GND DIR=HIGH V _{WP} =GND		36			µA
I _{CD}	CD pin input leakage current	1.8	3.0	V _{IA} =V _{CCA} or GND DIR=HIGH V _{CD} =GND		36			µA

Table 8. AC electrical characteristics (f = 1MHz, 50% duty cycle, C_L = 30pF, R_L = 500Ω)

Symbol	Parameter	Test condition T _A = -40 to 85 °C						Unit	
		V _{CCA} = 1.8 ± 0.15V		V _{CCA} =1.8 ± 0.15V		V _{CCA} =2.5 ± 0.2V			
		V _{CCB} =2.5 ± 0.2V		V _{CCB} =2.7 ± 0.3V		V _{CCB} =2.7 ± 0.3V			
		Min.	Max.	Min.	Max.	Min.	Max.		
t _{PLH} t _{PHL}	Propagation delay time An to Bn	1.0	7.2	1.0	6.6	1.0	6.1	ns	
t _{PLH} t _{PHL}	Propagation delay time Bn to An	1.0	5.8	1.0	5.4	1.0	4.8		
t _{OSLH} t _{OSHL}	Output to output skew time ⁽¹⁾⁽²⁾		0.5		0.5		0.5	ns	
t _{CDLH} t _{CDHL}	Clock and data skew time		0.5		0.5		0.5	ns	
f _{max}	Clock	From A to B	52		52		52		MHz
		From B to A	52		52		52		
	Data	From A to B	52		52		52		Mbps
		From B to A	52		52		52		

1. Skew is defined as the absolute value of the difference between the actual propagation delay for any two outputs of the same device switching in the same direction, either HIGH or LOW (t_{OSLH} = | t_{PLHm} - t_{PLHn} |, t_{OSHL} = | t_{PHLm} - t_{PHLn} |)
2. Parameter guaranteed by design.

Table 9. Output slew rate (f = 1MHz, 50% duty cycle, CL=30pF, RL=500Ω)

Symbol	Parameter	From	To	Test condition T _A = -40 to 85 °C		Unit
				V _{CCA} = 1.8V ± 0.15V V _{CCB} = 3V ± 0.3V		
				Min.	Max.	
t _r	Rise time	20%	80%		3	ns
t _f	Fall time	80%	20%		3	ns

Table 10. Capacitance characteristics

Symbol	Parameter	Test condition			Value					Unit
		V _{CCB} (V)	V _{CCA} (V)		T _A = 25 °C			-40 to 85 °C		
					Min.	Typ.	Max.	Min.	Max.	
C _{INB}	Input capacitance	open	open			9				pF
C _{I/OA}	Input/Output capacitance for A-SIDE	3.3	2.5			17				pF
C _{I/OB}	Input/Output capacitance for B-SIDE	3.3	2.5			33				pF
C _{PD} ⁽¹⁾	Power dissipation capacitance	3.3	2.5	f = 10MHz		29				pF
		3.3	1.8			29				

1. C_{PD} is defined as the value of the IC's internal equivalent capacitance which is calculated from the operating current consumption without load. (Refer to Test Circuit). Average current can be obtained by the following equation. I_{CC(opr)} - C_{PD} x V_{CC} x f_{IN} + I_{CC/16} (per circuit)

Note: V_{IA} = Input I/Os including CLK.h, CMD.h, DAT0.h, DAT1.h, DAT2.h, DAT3.h

10/17 V_{IB} = Input I/Os including CMD, DAT0, DAT1, DAT2, DAT3



6 I/O and test circuit

Figure 3. Input and output equivalent circuit

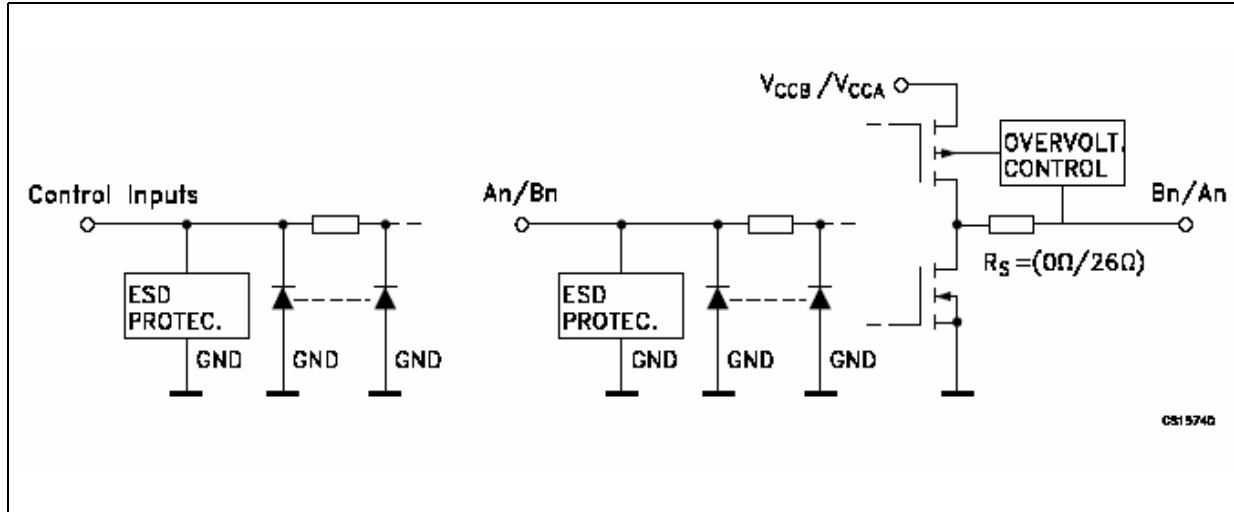

Figure 4. Test circuit

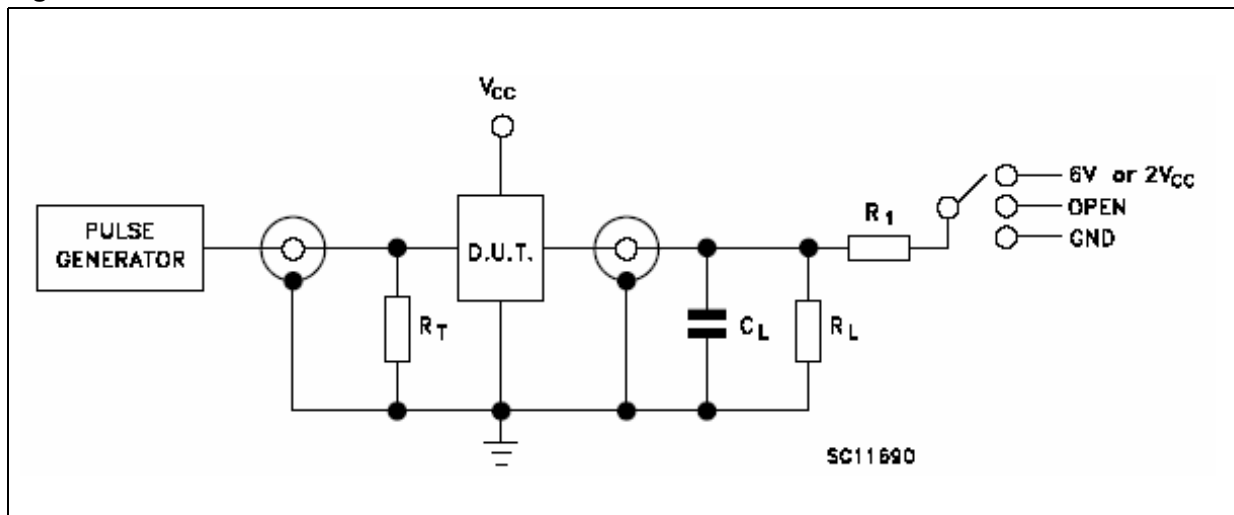

Table 11. Test values

Test	Switch
t_{PLH} , t_{PHL}	Open
t_{PZL} , t_{PLZ} ($V_{CC} = 3.0$ to $3.6V$)	6V
t_{PZL} , t_{PLZ} ($V_{CC} = 2.3$ to $2.7V$ or $V_{CC} = 1.6$ to $1.95V$)	$2V_{CC}$
t_{PZH} , t_{PHZ}	GND

7 Waveforms

Figure 5. Waveform - propagation delay (f = 1 MHz, 50% duty cycle)

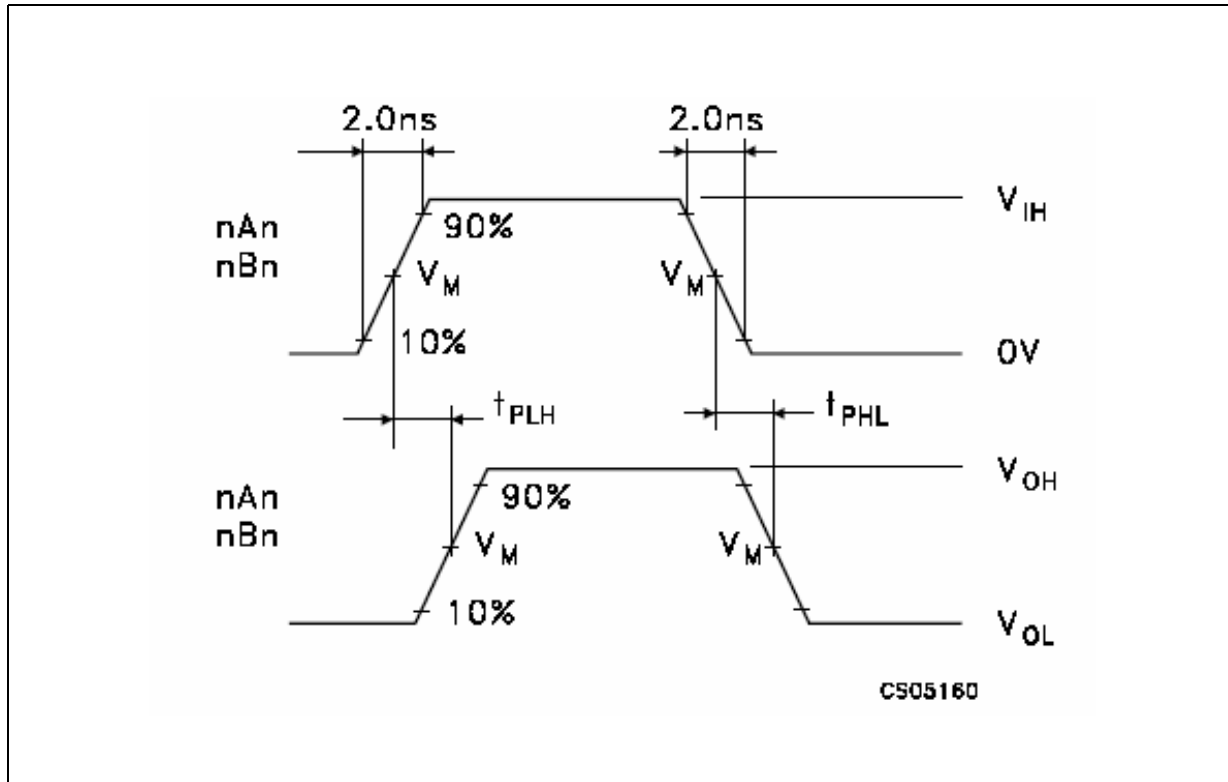

Table 12. Waveform symbol value

Symbol	V_{CC}		
	3.0 to 3.6V	2.3 to 2.7V	1.65 to 1.95V
V_{IH}	V_{CC}	V_{CC}	V_{CC}
V_M	1.5V	$V_{CC}/2$	$V_{CC}/2$
V_X	$V_{OL}+0.3V$	$V_{OL}+0.15V$	$V_{OL}+0.15V$
V_Y	$V_{OL}-0.3V$	$V_{OL}-0.15V$	$V_{OL}-0.15V$

Note: $C_L = 30pF$ or equivalent (includes jig and probe capacitance)
 $R_L = R1 = 500\Omega$ or equivalent
 $R_T = Z_{OUT}$ of pulse generator (typically 50Ω)

8 Package mechanical data

In order to meet environmental requirements, ST offers these devices in ECOPACK® packages. These packages have a Lead-free second level interconnect. The category of second Level Interconnect is marked on the package and on the inner box label, in compliance with JEDEC Standard JESD97. The maximum ratings related to soldering conditions are also marked on the inner box label. ECOPACK is an ST trademark. ECOPACK specifications are available at: www.st.com.

Table 13. μ TFBGA25 mechanical data

Dim Ref	Dimension (mm)			Dimension (inch)		
	Min.	Typ.	Max	Min.	Typ.	Max
A	1.0	1.10	1.16	0.039	0.043	0.046
A1			0.25			0.010
A2	0.78		0.86	0.031		0.034
b	0.25	0.30	0.35	0.010	0.012	0.014
D	2.90	3.0	3.10	0.114	0.118	0.122
D1		2.0			0.079	
E	2.90	3.0	3.10	0.114	0.118	0.122
E1		2.0			0.079	
e		0.50			0.020	
SE		0.25			0.010	

Figure 6. Package dimensions

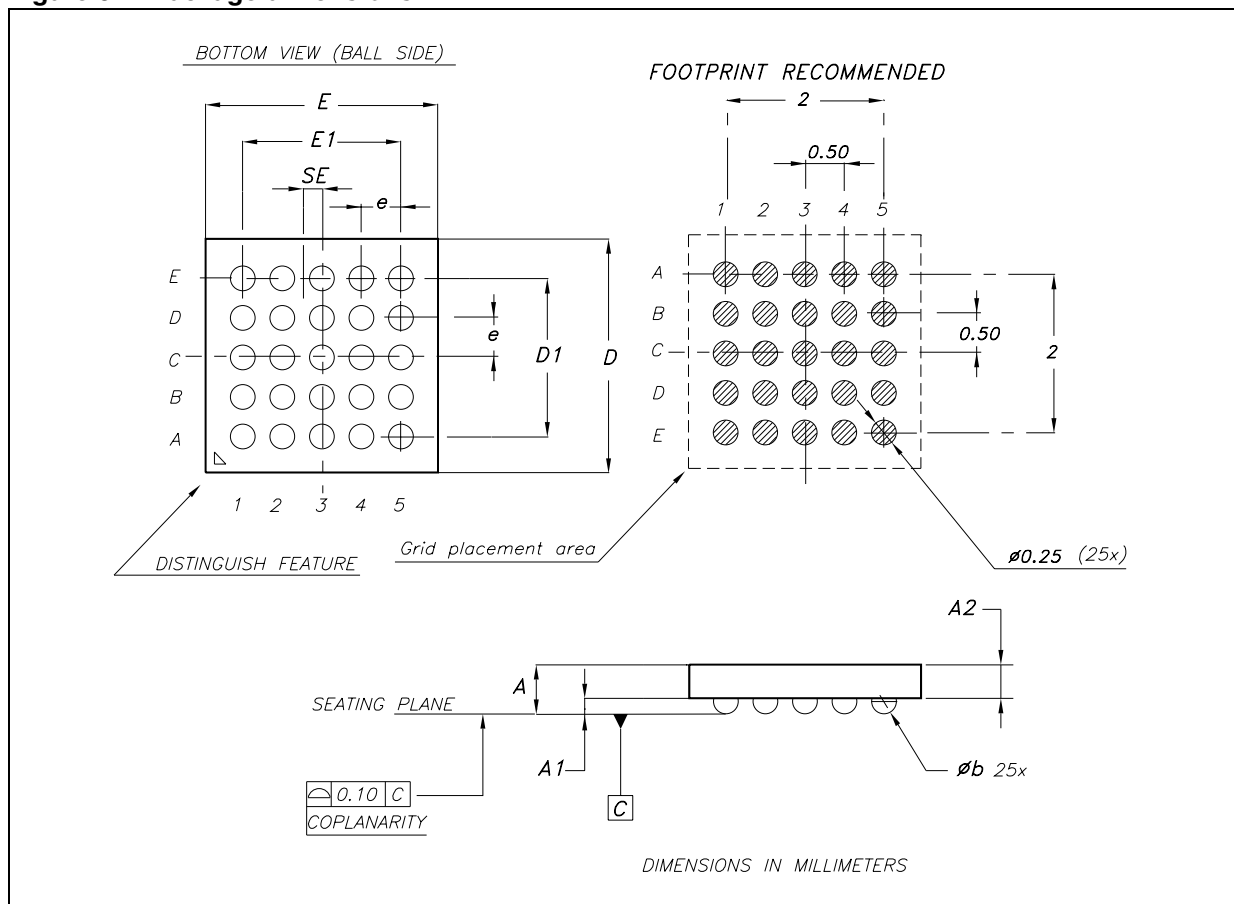
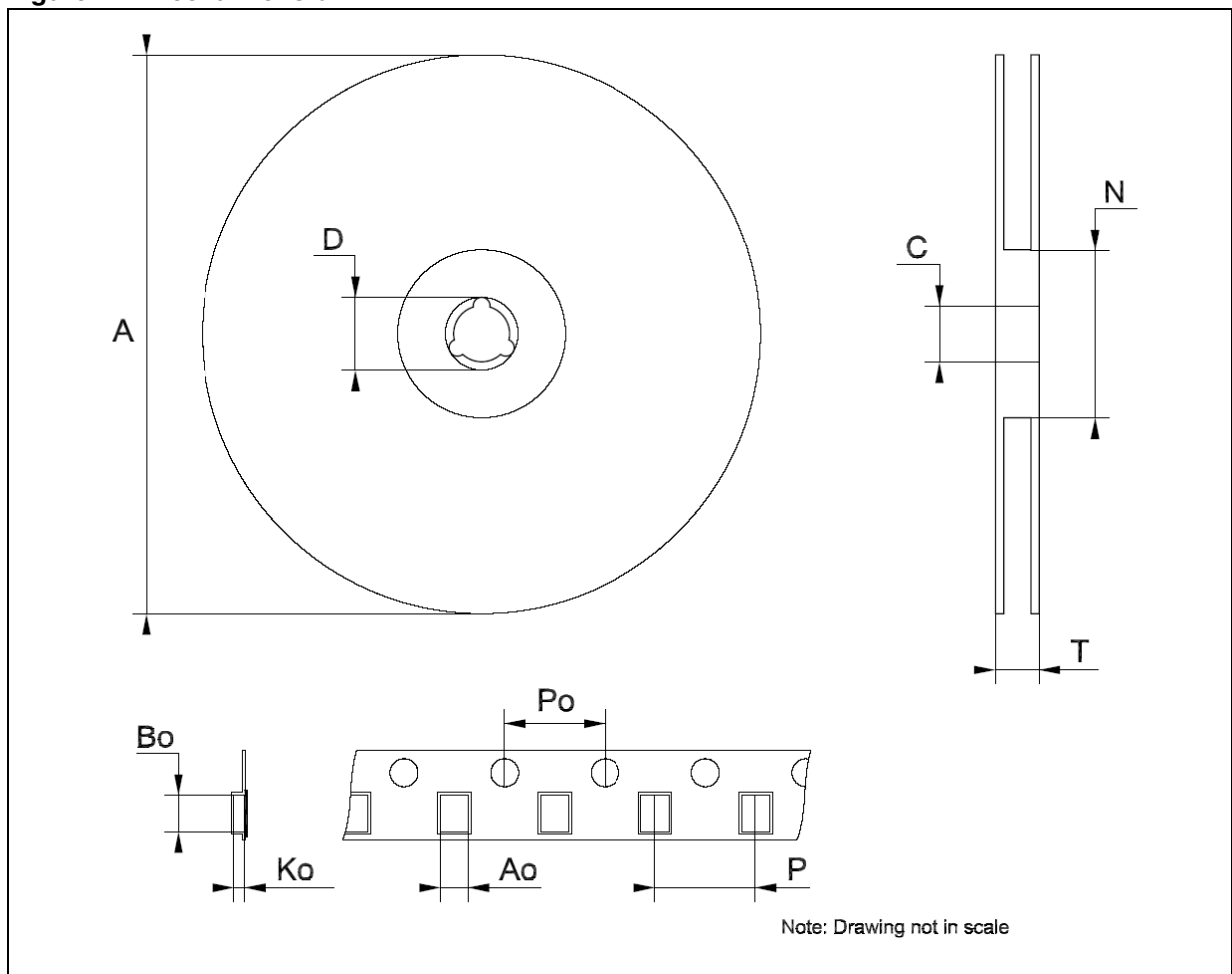

Table 14. μ TFBGA25 tape and reel information

Dim Ref	Dimension (mm)			Dimension (inch)		
	Min.	Typ.	Max	Min.	Typ.	Max
A			330			12.992
C	12.8		13.2	0.504		0.519
D	20.2			0.795		
N	60			2.362		
T			14.4			0.567
Ao		3.3			0.130	
Bo		3.3			0.130	
Ko		1.60			0.063	
Po	3.9		4.1	0.153		0.161
P	7.9		8.1	0.311		0.319

Figure 7. Reel dimension



9 Revision history

Table 15. Revision history

Date	Revision	Change
22-Mar-2007	1	First release

Please Read Carefully:

Information in this document is provided solely in connection with ST products. STMicroelectronics NV and its subsidiaries ("ST") reserve the right to make changes, corrections, modifications or improvements, to this document, and the products and services described herein at any time, without notice.

All ST products are sold pursuant to ST's terms and conditions of sale.

Purchasers are solely responsible for the choice, selection and use of the ST products and services described herein, and ST assumes no liability whatsoever relating to the choice, selection or use of the ST products and services described herein.

No license, express or implied, by estoppel or otherwise, to any intellectual property rights is granted under this document. If any part of this document refers to any third party products or services it shall not be deemed a license grant by ST for the use of such third party products or services, or any intellectual property contained therein or considered as a warranty covering the use in any manner whatsoever of such third party products or services or any intellectual property contained therein.

UNLESS OTHERWISE SET FORTH IN ST'S TERMS AND CONDITIONS OF SALE ST DISCLAIMS ANY EXPRESS OR IMPLIED WARRANTY WITH RESPECT TO THE USE AND/OR SALE OF ST PRODUCTS INCLUDING WITHOUT LIMITATION IMPLIED WARRANTIES OF MERCHANTABILITY, FITNESS FOR A PARTICULAR PURPOSE (AND THEIR EQUIVALENTS UNDER THE LAWS OF ANY JURISDICTION), OR INFRINGEMENT OF ANY PATENT, COPYRIGHT OR OTHER INTELLECTUAL PROPERTY RIGHT.

UNLESS EXPRESSLY APPROVED IN WRITING BY AN AUTHORIZED ST REPRESENTATIVE, ST PRODUCTS ARE NOT RECOMMENDED, AUTHORIZED OR WARRANTED FOR USE IN MILITARY, AIR CRAFT, SPACE, LIFE SAVING, OR LIFE SUSTAINING APPLICATIONS, NOR IN PRODUCTS OR SYSTEMS WHERE FAILURE OR MALFUNCTION MAY RESULT IN PERSONAL INJURY, DEATH, OR SEVERE PROPERTY OR ENVIRONMENTAL DAMAGE. ST PRODUCTS WHICH ARE NOT SPECIFIED AS "AUTOMOTIVE GRADE" MAY ONLY BE USED IN AUTOMOTIVE APPLICATIONS AT USER'S OWN RISK.

Resale of ST products with provisions different from the statements and/or technical features set forth in this document shall immediately void any warranty granted by ST for the ST product or service described herein and shall not create or extend in any manner whatsoever, any liability of ST.

ST and the ST logo are trademarks or registered trademarks of ST in various countries.

Information in this document supersedes and replaces all information previously supplied.

The ST logo is a registered trademark of STMicroelectronics. All other names are the property of their respective owners.

© 2007 STMicroelectronics - All rights reserved

STMicroelectronics group of companies

Australia - Belgium - Brazil - Canada - China - Czech Republic - Finland - France - Germany - Hong Kong - India - Israel - Italy - Japan - Malaysia - Malta - Morocco - Singapore - Spain - Sweden - Switzerland - United Kingdom - United States of America

www.st.com