

Low voltage dual SP4T switch

Features

- Ultra low power dissipation:
 - $I_{CC} = 0.1 \mu\text{A}$ (max.) at $T_A = 25 \text{ }^\circ\text{C}$
- Low “ON” resistance:
 - $R_{ON} = 4.6 \Omega$ ($T_A = 25 \text{ }^\circ\text{C}$) at $V_{CC} = 4.3 \text{ V}$
 - $R_{ON} = 5.8 \Omega$ ($T_A = 25 \text{ }^\circ\text{C}$) at $V_{CC} = 3.0 \text{ V}$
- Wide operating voltage range:
 - $V_{CC} \text{ (Opr)} = 1.65 \text{ to } 4.3 \text{ V}$ single supply
- 4.3 V tolerant and 1.8 V compatible threshold on digital control input at $V_{CC} = 2.3 \text{ to } 3.0 \text{ V}$
- Typical bandwidth (-3dB) at 300 MHz on all channels
- Latch-up performance exceeds 300 mA per JESD 78, Class II
- ESD performance exceeds JESD22
 - 2000-V Human body model (A114-A)

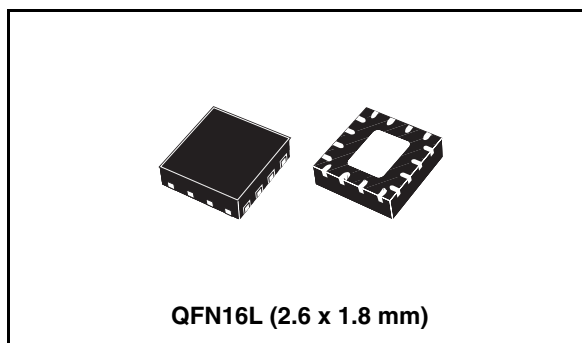

Description

The STG3482 is a high-speed CMOS low voltage dual analog SP4T (single pole four throw) switch or 4:1 multiplexer/demultiplexer switch fabricated in silicon gate C²MOS technology. It is designed to operate from 1.65 to 4.3 V, making this device ideal for portable applications.

By controlling the SEL1 and SEL2, one of the independent channels will be connected to the common channel. An /OE pin is also available in this device to disconnect all the switches.

Additional key features are fast switching speed, break-before-make delay time and ultra low power consumption. All inputs and outputs are equipped with protection circuits against static discharge, giving them ESD immunity and transient excess voltage.

Table 1. Device summary

| Order code | Package | Packaging |
|------------|-----------------------|---------------|
| STG3482QTR | QFN16L (2.6 x 1.8 mm) | Tape and reel |

Contents

| | | |
|----------|--------------------------------------------|-----------|
| 1 | Pin settings | 3 |
| | 1.1 Pin description | 3 |
| 2 | Device summary | 4 |
| 3 | Maximum rating | 5 |
| | 3.1 Recommended operating conditions | 5 |
| 4 | Electrical characteristics | 6 |
| 5 | Package mechanical data | 10 |
| 6 | Revision history | 13 |

1 Pin settings

Figure 1. Pin connection (top through view)

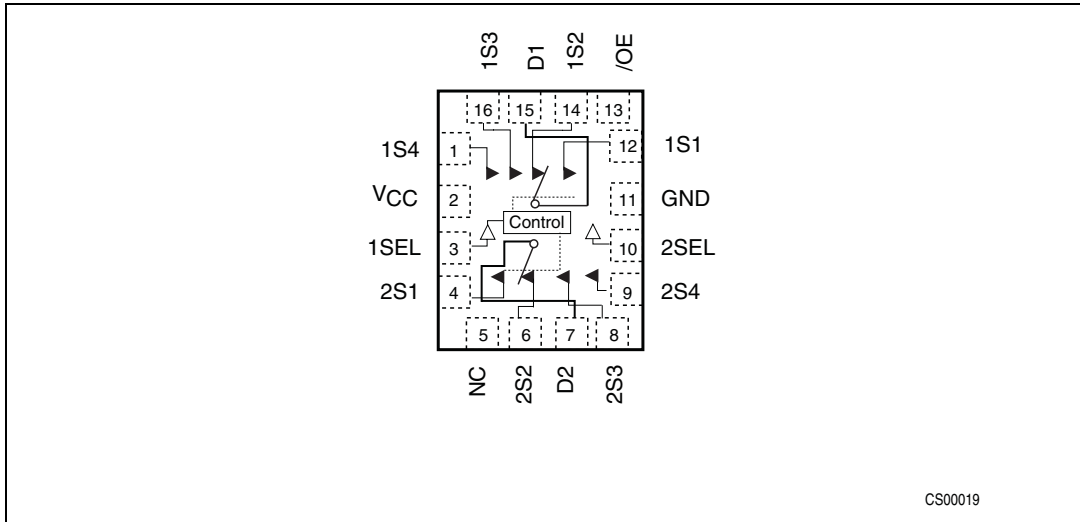

CS00019

1.1 Pin description

Table 2. Pin description

| Pin number | Symbol | Name and function |
|------------|-----------------|----------------------------|
| 1 | 1S4 | Independent channel |
| 2 | V _{CC} | Positive supply voltage |
| 3 | 1SEL | Control |
| 4 | 2S1 | Independent channel |
| 5 | NC | No connect |
| 6 | 2S2 | Independent channel |
| 7 | D2 | Common channels |
| 8 | 2S3 | Independent channel |
| 9 | 2S4 | Independent channel |
| 10 | 2SEL | Control |
| 11 | GND | Ground (0V) |
| 12 | 1S1 | Independent channel |
| 13 | /OE | Output enable (active low) |
| 14 | 1S2 | Independent channel |
| 15 | D1 | Common channel |
| 16 | 1S3 | Independent channel |

Note: Exposed pad must be soldered to a floating plane. Do NOT connect to power or ground.

2 Device summary

Figure 2. Input equivalent circuit

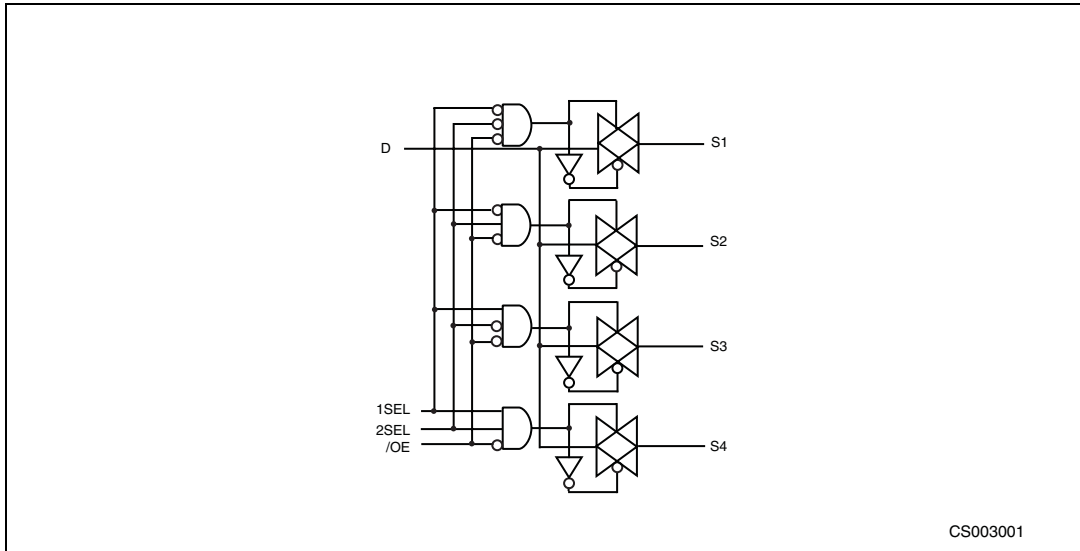

Table 3. Truth table

| /OE | 1SEL | 2SEL | Switch connection |
|-----|------|------|-------------------|
| H | X | X | High-Z |
| L | L | L | D1-1S1, D2-2S1 |
| L | L | H | D1-1S2, D2-2S2 |
| L | H | L | D1-1S3, D2-2S3 |
| L | H | H | D1-1S4, D2-2S4 |

3 Maximum rating

Stressing the device above the rating listed in the “Absolute maximum ratings” table may cause permanent damage to the device. These are stress ratings only and operation of the device at these or any other conditions above those indicated in the Operating sections of this specification is not implied. Exposure to absolute maximum rating conditions for extended periods may affect device reliability. Refer also to the STMicroelectronics SURE Program and other relevant quality documents.

Table 4. Absolute maximum ratings

| Symbol | Parameter | Value | Unit |
|-----------------------|----------------------------------------------------------|------------------------|------------|
| V_{CC} | Supply voltage | -0.5 to 5.5 | V |
| V_I | DC input voltage | -0.5 to $V_{CC} + 0.5$ | V |
| V_{IC} | DC control input voltage | -0.5 to 5.5 | V |
| V_O | DC output voltage | -0.5 to $V_{CC} + 0.5$ | V |
| I_{IKC} | DC input diode current on control pin ($V_{SEL} < 0V$) | -50 | mA |
| I_{IK} | DC input diode current ($V_{SEL} < 0V$) | ± 50 | mA |
| I_{OK} | DC output diode current | ± 20 | mA |
| I_O | DC output current | ± 128 | mA |
| I_{OP} | DC output current peak (pulse at 1ms, 10% duty cycle) | ± 300 | mA |
| I_{CC} or I_{GND} | DC V_{CC} or ground current | ± 100 | mA |
| P_D | Power dissipation at $T_A = 70^\circ C^{(1)}$ | 1120 | mW |
| T_{stg} | Storage temperature | -65 to 150 | $^\circ C$ |
| T_L | Lead temperature (10 sec) | 300 | $^\circ C$ |

1. Derate above 70 $^\circ C$ by 18.5 mW/ $^\circ C$

3.1 Recommended operating conditions

Table 5. Recommended operating conditions

| Symbol | Parameter | Value | Unit |
|----------|----------------------------------------|----------------------------|------------|
| V_{CC} | Supply voltage | 1.65 to 4.3 | V |
| V_I | Input voltage | 0 to V_{CC} | V |
| V_{IC} | Control input voltage | 0 to 4.3 | V |
| V_O | Output voltage | 0 to V_{CC} | V |
| T_{op} | Operating temperature | -40 to 85 | $^\circ C$ |
| dt/dv | Input rise and fall time control input | $V_{CC} = 1.65$ to 2.7 V | 0 to 20 |
| | | $V_{CC} = 3.0$ to 4.3 V | 0 to 10 |
| | | | ns/V |

4 Electrical characteristics

Table 6. DC specifications

| Symbol | Parameter | Test conditions | | Value | | | | Unit |
|-------------------|-----------------------------------------------------|------------------------|------------------------------------------------------------------|------------|------|----------------------|------|------|
| | | V _{CC} (V) | | TA = 25 °C | | -40 to 85 °C | | |
| | | | | Typ | Max | Min | Max | |
| V _{IH} | High level input voltage | 1.65 –1.95 | | | | 0.65 V _{CC} | | V |
| | | 2.3 –2.5 | | | | 1.2 | | |
| | | 2.7 –3.0 | | | | 1.3 | | |
| | | 3.3 –3.6 | | | | 1.4 | | |
| | | 4.3 | | | | 1.6 | | |
| V _{IL} | Low level input voltage | 1.65 –1.95 | | | 0.25 | | 0.25 | V |
| | | 2.3 –2.5 | | | 0.25 | | 0.25 | |
| | | 2.7 –3.0 | | | 0.25 | | 0.25 | |
| | | 3.3 –3.6 | | | 0.30 | | 0.30 | |
| | | 4.3 | | | 0.40 | | 0.40 | |
| R _{PEAK} | Switch on peak resistance | 1.8 | V _S = 0 V to V _{CC} I _S = 8 mA | 12.0 | 16.0 | | | Ω |
| | | 2.7 | | 6.3 | 8.0 | | | |
| | | 3.0 | | 5.8 | 7.5 | | | |
| | | 3.7 | | 5.0 | 6.5 | | | |
| | | 4.3 | | 4.6 | 6.0 | | | |
| R _{ON} | Switch ON resistance | 3.0 | V _S = 3 V I _S = 8 mA | 4.0 | 5.2 | | | Ω |
| | | 3.0 | V _S = 0.8 V I _S = 8 mA | 5.0 | 6.5 | | | |
| ΔR _{ON} | ON resistance match between channels ⁽¹⁾ | 1.8 | V _S @ R _{ON} Max I _S = 8mA | 0.3 | | | | Ω |
| | | 2.7 | | 0.3 | | | | |
| | | 3.0 | | 0.3 | | | | |
| | | 3.7 | | 0.3 | | | | |
| | | 4.3 | | 0.3 | | | | |
| R _{FLAT} | ON resistance flatness ⁽²⁾ | 1.8 | V _S = 0V to V _{CC} I _S = 8mA | 5.9 | | | | Ω |
| | | 2.7 | | 1.9 | | | | |
| | | 3.0 | | 1.6 | | | | |
| | | 3.7 | | 1.4 | | | | |
| | | 4.3 | | 1.6 | | | | |

Table 6. DC specifications

| Symbol | Parameter | Test conditions | | Value | | | | Unit |
|-------------------|----------------------------------------------|------------------------|-----------------------------------------------------------------------|------------|------|--------------|------|------|
| | | V _{CC} (V) | | TA = 25 °C | | -40 to 85 °C | | |
| | | | | Typ | Max | Min | Max | |
| I _{OFF} | OFF state leakage current (SN), (D) | 4.3 | V _S = 0.3 or 4 V | | ±20 | | ±100 | nA |
| I _{IN} | Input leakage current | 0 to 4.3 | V _{SEL} = 0 to 4.3 V | | ±0.1 | | ±1 | μA |
| I _{CC} | Quiescent supply current | 1.65 to 4.3 | V _{SEL} = V _{CC} or GND | | ±0.1 | | ±1.0 | μA |
| I _{CCLV} | Quiescent supply current low voltage driving | 4.3 | V _{1SEL} , V _{2SEL} = 1.65 V | ±37 | ±50 | | ±100 | μA |
| | | | V _{1SEL} , V _{2SEL} = 1.80 V | ±33 | ±40 | | ±50 | |
| | | | V _{1SEL} , V _{2SEL} = 2.60 V | ±12 | ±20 | | ±30 | |
| | | | V _{1SEL} , V _{2SEL} = 0 V _{OE} = 1.65 V | ±19 | ±25 | | ±50 | |
| | | | V _{1SEL} , V _{2SEL} = 0 V _{OE} = 1.80 V | ±17 | ±20 | | ±25 | |
| | | | V _{1SEL} , V _{2SEL} = 0 V _{OE} = 2.60 V | ±6 | ±10 | | ±15 | |

1. $\Delta R_{on} = R_{on(max)} - R_{on(Min)}$
2. Flatness is defined as the difference between the maximum and minimum value of on-resistance as measured over the specified analog signal ranges.

Table 7. AC electrical characteristics ($C_L = 35 \text{ pF}$, $R_L = 50 \text{ } \Omega$, $t_r = t_f \leq 5 \text{ ns}$)

| Symbol | Parameter | Test conditions | | Value | | | | | Unit |
|-------------------------------------|------------------------------|-----------------|-----------------------------------------------------------------------------|------------------------|------|-----|--------------|-----|------|
| | | Vcc (V) | | T _A = 25 °C | | | -40 to 85 °C | | |
| | | | | Min | Typ | Max | Min | Max | |
| t _{PLH} , t _{PHL} | Propagation delay | 1.65 – 1.95 | | | 0.30 | | | | ns |
| | | 2.3 – 2.7 | | | 0.30 | | | | |
| | | 3.0 – 3.3 | | | 0.27 | | | | |
| | | 3.6 – 4.3 | | | 0.28 | | | | |
| t _{ON} | Turn-ON time | 1.65 – 1.95 | V _S = 0.8 V | | 37 | | | ns | |
| | | 2.3 – 2.7 | | | 20 | 30 | | | 34 |
| | | 3.0 – 3.3 | V _S = 1.5 V | | 15 | 25 | | | 26 |
| | | 3.6 – 4.3 | | | 12 | 18 | | | 20 |
| t _{OFF} | Turn-OFF time | 1.65 – 1.95 | V _S = 0.8 | | 23 | | | ns | |
| | | 2.3 – 2.7 | | | 17 | 23 | | | 17 |
| | | 3.0 – 3.3 | V _S = 1.5 V | | 12 | 18 | | | 12 |
| | | 3.6 – 4.3 | | | 10 | 15 | | | 10 |
| t _D | Break before make time delay | 1.65 – 1.95 | | 1 | 24 | | | ns | |
| | | 2.3 – 2.7 | C _L = 35 pF R _L = 50 Ω V _S = 1.5 V | 1 | 15 | | | | |
| | | 3.0 – 3.3 | | 1 | 11 | | | | |
| | | 3.6 – 4.3 | | 1 | 9 | | | | |
| Q | Charge injection | 1.65 | | | 10 | | | pC | |
| | | 2.3 | C _L = 100 pF V _{GEN} = 0 V R _{GEN} = 0 Ω | | 11 | | | | |
| | | 3.0 | | | 11 | | | | |
| | | 4.3 | | | 11 | | | | |

Table 8. Analog switch characteristics ($C_L = 5\text{pF}$, $R_L = 50\Omega$, $T_A = 25^\circ\text{C}$)

| Symbol | Parameter | Test conditions | | Value | | | | | Unit |
|------------------|---------------------------------------------|------------------------|-------------------------------------------------------------------------------------------------------------------------------------------------------|------------------------|------|------|--------------|-----|------|
| | | V _{CC} (V) | | T _A = 25 °C | | | -40 to 85 °C | | |
| | | | | Min | Typ | Max | Min | Max | |
| OIRR | OFF Isolation ⁽¹⁾ | 1.65 — 4.3 | V _S = 1V _{RMS} , f = 1 MHz Signal = 0 dBm | | -75 | | | | dB |
| | | | V _S = 1V _{RMS} , f = 10 MHz Signal = 0 dBm | | -58 | | | | |
| Xtalk | Crosstalk | 1.65 — 4.3 | V _S = 1V _{RMS} , f = 1 MHz Signal = 0 dBm | | -77 | | | | dB |
| | | | V _S = 1V _{RMS} , f = 10 MHz Signal = 0 dBm | | -60 | | | | |
| THD | Total harmonic distortion | 3.7 | f = 20 Hz to 20 kHz R _L = 32 Ω, C _L = 50 Ω V _{IN} = 2.8 V _{P-P} V _{DC} = V _{CC} /2 | | 0.01 | 0.02 | | | % |
| PSRR | Power supply rejection ratio | 3.7 | f = 217 Hz, R _L = 32 Ω, C _L = 50 Ω V _{ripple} = 150 mV V _{DC} = V _{CC} /2 | | -60 | | | | dB |
| BW | -3dB bandwidth | 3.0 — 4.3 | R _L = 50 Ω Bias = 1 V | | 300 | | | | MHz |
| D _G | Differential gain | 3.0 — 4.3 | R _L = 150 Ω | | 0.64 | | | | % |
| D _P | Differential phase | 3.0 — 4.3 | R _L = 150 Ω | | 0.1 | | | | deg |
| C _{IN} | Control pin input capacitance | | V _{CC} = 0 V | | 1.5 | | | | pF |
| C _{ON} | Sn port capacitance when switch is enabled | 3.3 | f = 1 MHz | | 6.7 | | | | |
| C _{OFF} | Sn port capacitance when switch is disabled | 3.3 | f = 1 MHz | | 2.8 | | | | |

1. Off Isolation = $20\text{Log}_{10}(V_D/V_S)$, V_D = output. V_S = input to off switch.

5 Package mechanical data

In order to meet environmental requirements, ST offers these devices in ECOPACK® packages. These packages have a Lead-free second level interconnect. The category of second level interconnect is marked on the package and on the inner box label, in compliance with JEDEC Standard JESD97. The maximum ratings related to soldering conditions are also marked on the inner box label. ECOPACK is an ST trademark. ECOPACK specifications are available at: www.st.com.

Figure 3. QFN16L (2.6 x 1.8 mm) package outline

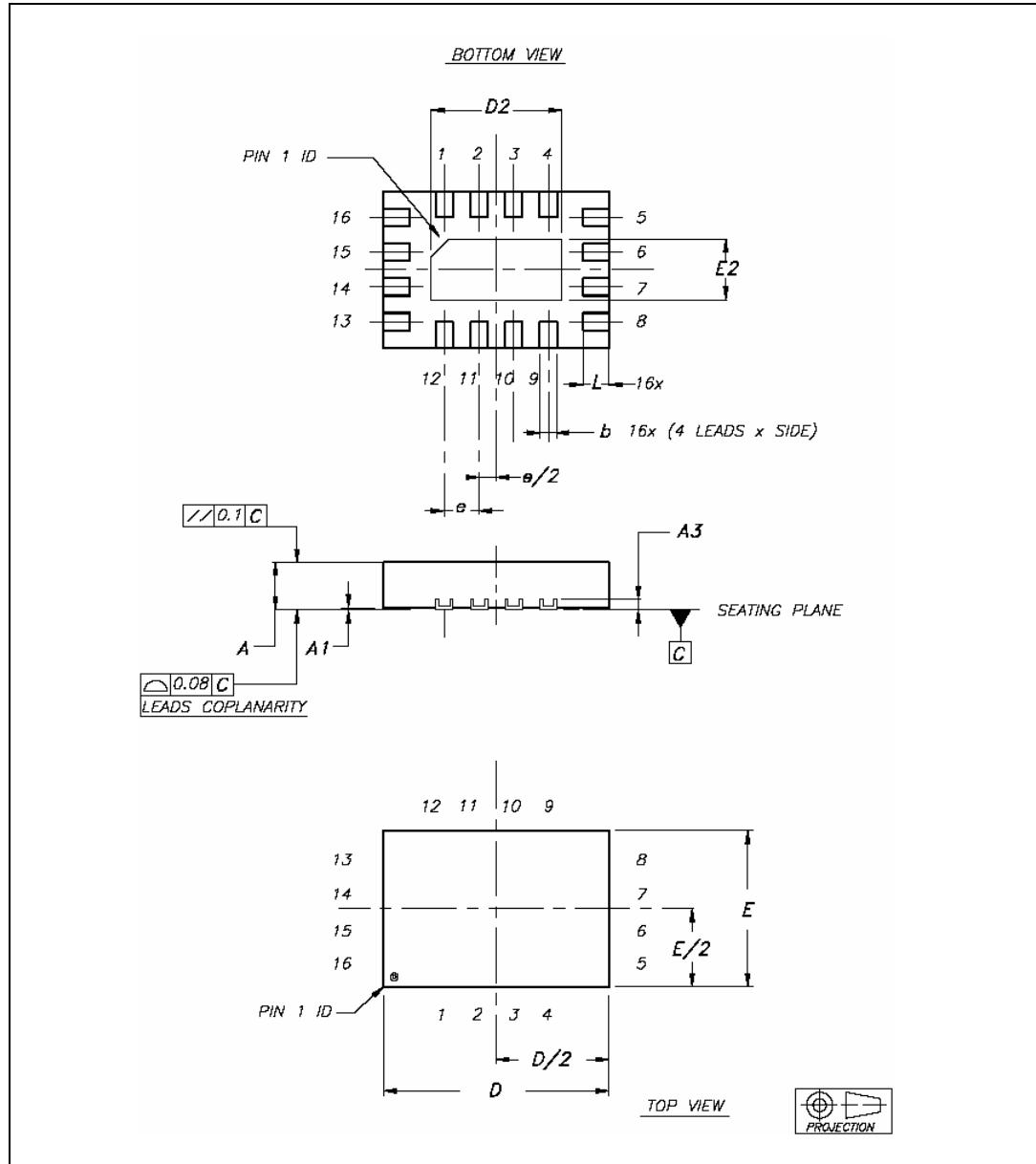
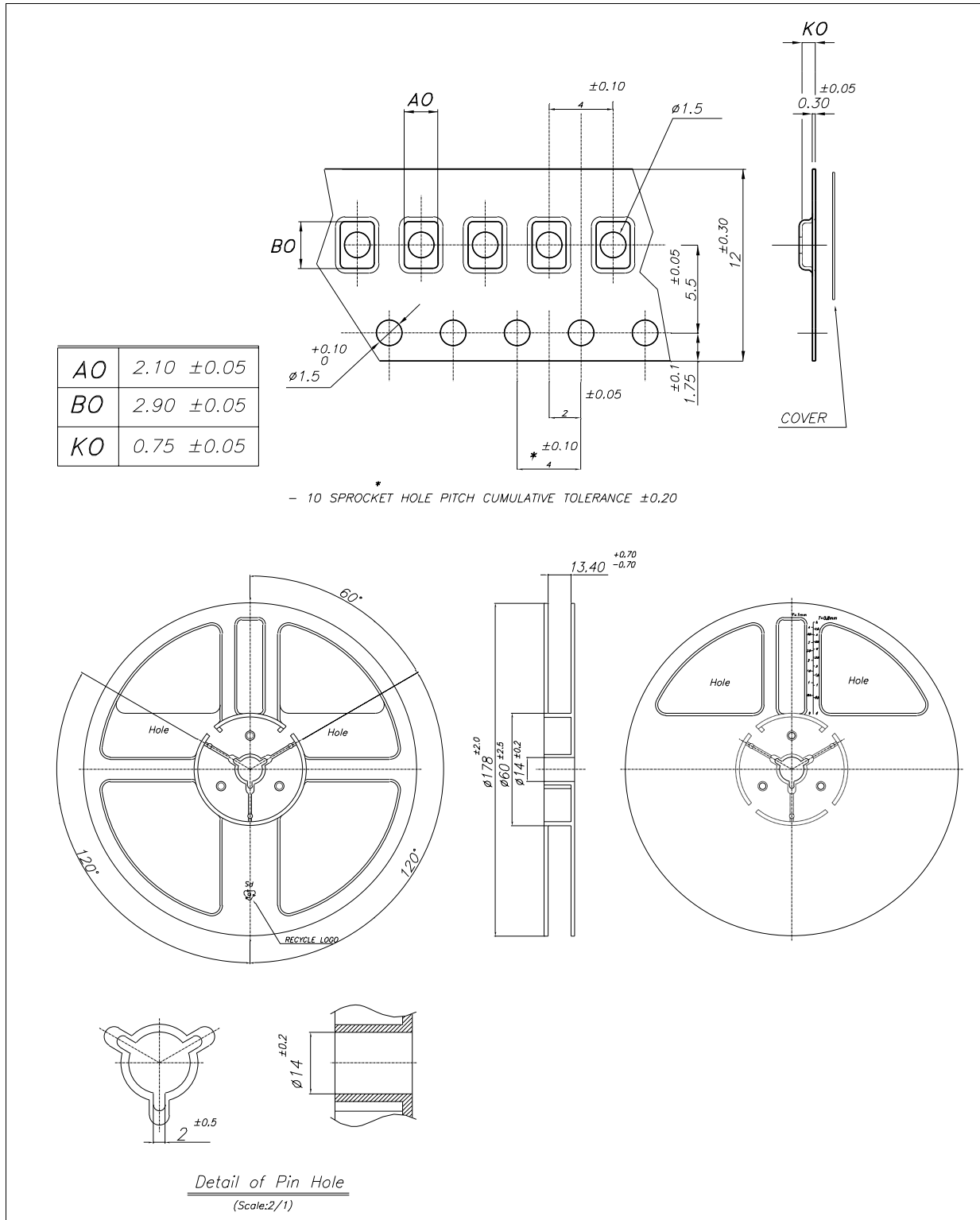

Table 9. QFN16L (2.6 x 1.8 mm) mechanical data

| Symbol | Millimeters | | |
|--------|-------------|------|------|
| | Typ | Min | Max |
| A | 0.50 | 0.45 | 0.55 |
| A1 | 0.02 | 0 | 0.05 |
| A3 | 0.127 | | |
| b | 0.20 | 0.15 | 0.25 |
| D | 2.60 | 2.50 | 2.70 |
| D2 | 1.50 | 1.40 | 1.60 |
| E | 1.80 | 1.70 | 1.90 |
| E2 | 0.70 | 0.60 | 0.80 |
| e | 0.40 | | |
| L | 0.30 | 0.25 | 0.35 |

1. VFQFPN - standard for thermally enhanced very fine pitch quad flat package no leads.
2. The leads size is comprehensive of the thickness of the leads finishing material.
3. Dimensions do not include mold protrusion.
4. Package outline exclusive of metal burrs dimensions.
5. Shipping media tape and reel units: 3000

Figure 4. QFN16L (2.6 x 1.8 mm) tape and reel



6 Revision history

Table 10. Document revision history

| Date | Revision | Changes |
|-------------|----------|-----------------------------------------------------------------------------------------------------------------------------------------------------------------------------------------------------------------------------------------------|
| 21-Nov-2006 | 1 | Initial release. |
| 20-Nov-2007 | 2 | Updated latch-up performance value in <i>Features section n on page 1</i> , minor text changes, updated <i>Figure 1 on page 3</i> , <i>Table 2 on page 3</i> , <i>Table 5 on page 5</i> , <i>Table 6 on page 6</i> , <i>Table 7 on page 8</i> |

Please Read Carefully:

Information in this document is provided solely in connection with ST products. STMicroelectronics NV and its subsidiaries ("ST") reserve the right to make changes, corrections, modifications or improvements, to this document, and the products and services described herein at any time, without notice.

All ST products are sold pursuant to ST's terms and conditions of sale.

Purchasers are solely responsible for the choice, selection and use of the ST products and services described herein, and ST assumes no liability whatsoever relating to the choice, selection or use of the ST products and services described herein.

No license, express or implied, by estoppel or otherwise, to any intellectual property rights is granted under this document. If any part of this document refers to any third party products or services it shall not be deemed a license grant by ST for the use of such third party products or services, or any intellectual property contained therein or considered as a warranty covering the use in any manner whatsoever of such third party products or services or any intellectual property contained therein.

UNLESS OTHERWISE SET FORTH IN ST'S TERMS AND CONDITIONS OF SALE ST DISCLAIMS ANY EXPRESS OR IMPLIED WARRANTY WITH RESPECT TO THE USE AND/OR SALE OF ST PRODUCTS INCLUDING WITHOUT LIMITATION IMPLIED WARRANTIES OF MERCHANTABILITY, FITNESS FOR A PARTICULAR PURPOSE (AND THEIR EQUIVALENTS UNDER THE LAWS OF ANY JURISDICTION), OR INFRINGEMENT OF ANY PATENT, COPYRIGHT OR OTHER INTELLECTUAL PROPERTY RIGHT.

UNLESS EXPRESSLY APPROVED IN WRITING BY AN AUTHORIZED ST REPRESENTATIVE, ST PRODUCTS ARE NOT RECOMMENDED, AUTHORIZED OR WARRANTED FOR USE IN MILITARY, AIR CRAFT, SPACE, LIFE SAVING, OR LIFE SUSTAINING APPLICATIONS, NOR IN PRODUCTS OR SYSTEMS WHERE FAILURE OR MALFUNCTION MAY RESULT IN PERSONAL INJURY, DEATH, OR SEVERE PROPERTY OR ENVIRONMENTAL DAMAGE. ST PRODUCTS WHICH ARE NOT SPECIFIED AS "AUTOMOTIVE GRADE" MAY ONLY BE USED IN AUTOMOTIVE APPLICATIONS AT USER'S OWN RISK.

Resale of ST products with provisions different from the statements and/or technical features set forth in this document shall immediately void any warranty granted by ST for the ST product or service described herein and shall not create or extend in any manner whatsoever, any liability of ST.

ST and the ST logo are trademarks or registered trademarks of ST in various countries.

Information in this document supersedes and replaces all information previously supplied.

The ST logo is a registered trademark of STMicroelectronics. All other names are the property of their respective owners.

© 2007 STMicroelectronics - All rights reserved

STMicroelectronics group of companies

Australia - Belgium - Brazil - Canada - China - Czech Republic - Finland - France - Germany - Hong Kong - India - Israel - Italy - Japan - Malaysia - Malta - Morocco - Singapore - Spain - Sweden - Switzerland - United Kingdom - United States of America

www.st.com