

Front panel controller/driver with standby power management

Datasheet – not recommended for new design

Features

- IC front panel controller/driver
- Timing power standby management controller
- IC power supply from 3.3V (V_{DD}) to -30V (V_{SS})
- Integrated VFD driver and controller
- Infrared (IR) Remote Control (RC) Decoder (Philips or NEC format)
- Drives many display modes (12 segments/16 digits to 20 segments/8 digits)
- High voltage outputs ($V_{DD} - 33.3V$ max)
- No external resistors necessary for driver outputs (P-channel open-drain with pull-down resistor outputs)
- Key scanning (up to 12mm x 2mm matrix)
- LED ports (4 channels, 20mA, max)
- Serial interface (STB, CLK, D_{IN} , and D_{OUT}) communication protocol
- Dimming circuit (adjustable up to 8 steps)
- Supports auto-increment of display digit, which lightens the load on the MCU
- Programmable 8 hot keys for the IR remote control command
- Programmable 8 hot keys for key scan command
- Low power consumption in standby mode
- 2 general-purpose input ports (SW1, SW2)
- Available in PQFP-52 package

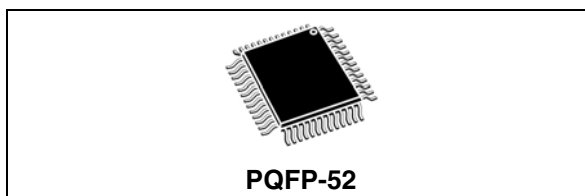

Description

The STFPC311 is a complete, low-cost, integrated solution for controlling and driving a front panel Vacuum Fluorescent Display (VFD). It is ideal for decreasing power consumption in standby mode by reducing the application standby current to a minimum. It also contains a built-in remote control decoder module.

While in standby mode of operation, a valid key press or signal from the infrared decoder will start a proper power-up (see [Figure 6 on page 13](#)).

The STFPC311 integrates a VFD controller with a driver that is run on a 1/8 to 1/16-duty factor. It consists of 12 segment output lines, 8 grid output lines, 8 shared segments/grid output drive lines, a display memory, a control circuit, and a key scan circuit. Serial data is input to the STFPC311 through the SPI interface of a microcontroller (STB, D_{IN} , D_{OUT} , and CLK).

Additionally, this IC can support two general-purpose input switches (SW1 and SW2).

Applications

- DVD players
- VCD players
- AV equipment like Home Stereo
- POS Systems

Table 1. Device summary

Part number	Temperature range	Package
STFPC311	-40°C to 85°C	PQFP-52

Contents

1	Functional description	4
1.1	Block diagram	5
2	Pin connections	6
2.1	Pin description	7
3	Initialization	8
3.1	Normal mode of operation	8
3.2	Receive operation	8
3.3	Transmit operation	8
3.4	Standby or power-down mode	9
3.5	IR decoding	9
3.6	Watchdog timer	9
3.6.1	Watchdog timer operation during power-up	10
3.6.2	Watchdog timer operation during power-down	11
3.6.3	Watchdog timer operation during standby	12
3.7	Flowcharts	13
4	Display RAM address and display mode	16
5	Data	18
5.1	LED port	18
5.2	SW data	18
6	Commands	19
6.1	Configuration mode setting command	19
6.2	Data setting command	20
6.3	Address setting command	21
6.4	Display control and hotkey setting command	21
7	Programmable hotkeys	23
7.1	IR Remote control	23
7.2	Front panel keys	23

8	Default status	25
8.1	Power-up default status	25
8.2	STANDBY status	25
9	Remote control protocols	26
9.1	RC-5 remote control	26
9.2	SPI interface IR data transmission	27
9.3	NEC remote control	27
10	Maximum rating	28
10.1	Power consumption estimation	29
11	Electrical characteristics	30
12	Timing characteristics	31
13	Serial communication format	32
14	Typical application diagram	35
15	Package mechanical data	36
16	Revision history	38

1 Functional description

The STFPC311 receives serial data from the microcontroller through the SPI interface, latches the data, and then masks the inputs from the MCU. This data consists of commands followed by data. There are 4 types of commands:

- configuration,
- data,
- address, and
- display.

The STFPC311 integrates the supply standby power management functionality, remote control decoder, and a 28-bit VFD driver. Microcontrollers usually run the first two tasks.

This device reduces the stand-by power consumption of the whole Front Panel application as well as the hardware by integrating the infrared (IR) remote control decoder.

A dedicated supply voltage powers the STFPC311 directly from the main supply board. When power is plugged in, control of the power supply management is done using the following pins:

1. STBY,
2. IR_DATA_IN, and
3. READY.

1.1 Block diagram

Figure 1. Block diagram

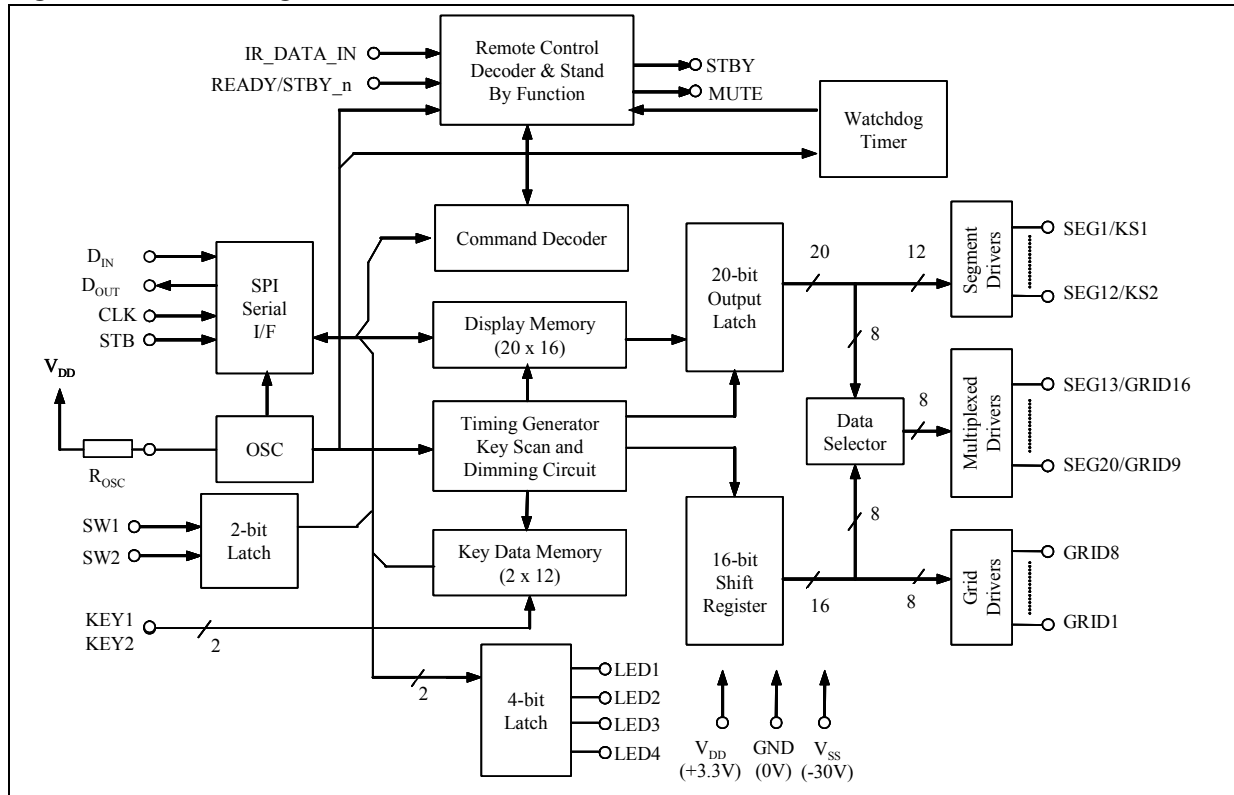

2 Pin connections

Figure 2. Connection diagram (top view PQFP-52)

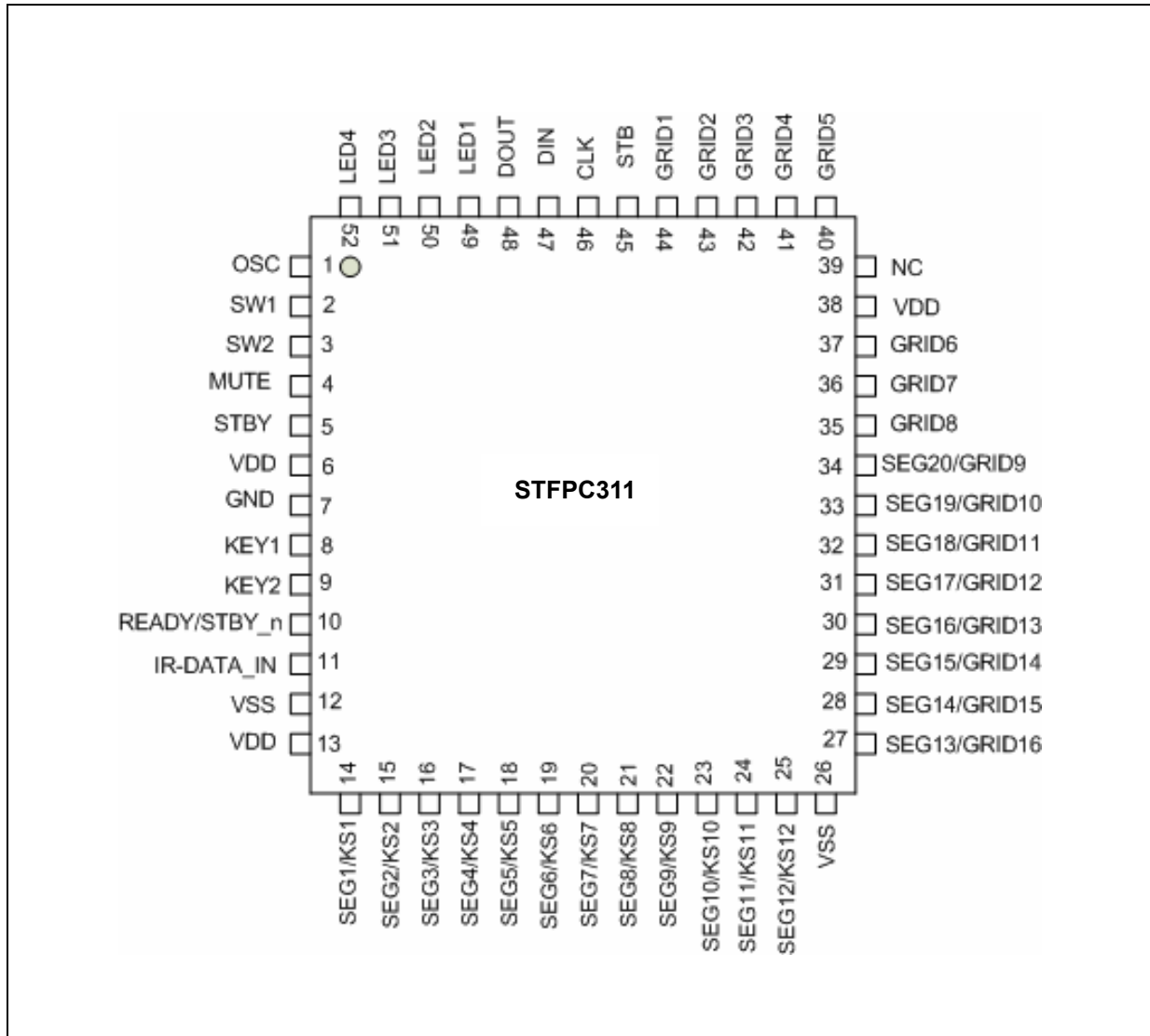

Note: For a description of the behavior of each pin, refer to the [Table 2: Pin description on page 7](#).

2.1 Pin description

Table 2. Pin description

Pin N°	Symbol	Type	Name and function
1	OSC	I	This is the oscillator input pin. Connect this pin to an external resistor.
2, 3	SW1, SW2	I	General purpose switch input ports.
4	MUTE	O	High level indicates mute status for audio. Low level indicates normal working. See Note :
5S	TBY	O	there is a typo. Pin5 and name is STBY. Standby output to put the MCU in low power mode. It is a command to the main power board. High level indicates stand-by status. Low level indicates normal working. See Note :
7	GND	POWER	Connect this pin to system GND.
8, 9	KEY1, KEY2	I	Input data to these pins from external keyboard are latched at end of the display cycle (maximum keyboard size is 12 x 2).
10	READY	I	High level on this pin means that main board chip has been working normally. See Note : This pin should never float. It is recommended have a pull-down resistor on this input.
1	IR_DATA_IN	I	Remote control input. Feeds the IR data from photodiode to this pin.
14 to 25	SEG1/KS1 to SEG12/KS12	O	Segment output pins (dual function as key source).
12, 26	V _{SS}	POWER	V _{FD} outputs high voltage pull-down level. V _{DD} --33.3V max.
27 to 34	SEG13/GRID16 to SEG20/GRID9	O	These pins are selectable for segment or grid driving.
35 to 37	GRID8 to GRID6	O	Grid output pins.
6, 13,38	V _{DD}	POWER	3.3V ± 0.3V Core main supply voltage.
39	NC	O	Not used. Left unconnected.
40 to 44	GRID5 to GRID1	O	Grid output pins.
45	STB	I	Initializes the serial interface at the rising or falling edge to make the STFPC31 wait for reception of command. The data input after the falling edge of STB is processed as a command. While the command data is processed, current processing is stopped, and the serial interface is initialized. While STB is high, CLK is ignored and any instruction from the MCU is neglected.
46	CLK	I	Reads serial data at the rising edge, and outputs data at the falling edge.
47	D _{IN}	I	Inputs serial data at the rising edge of the shift clock, starting from the lower bit.
48	D _{OUT}	O	Outputs serial data at the falling edge of the shift clock, starting from the lower bit. This is the N-channel opendrain output pin.
49-52	LED1, LED2, LED3, LED4	O	CMOS outputs (20mA, max).

Note: For a detailed behavioral description of these pins, refer to the “STFPC311 Timing Power Stand-by Sequencer Flow-Chart”. See [Table 6 on page 13](#).

3 Initialization

After the power is plugged in, the device will supply power to all of the components (including the host processor) by setting STBY to logic low in order to allow the host processor to program the STFPC311. Once the STBY is set to low, the watchdog timer starts to count up to 10s (10s is the default value of the watchdog timer upon power-up). When the READY is asserted within this time, it indicates that the system has booted up well. If the READY pin is not asserted (logic high) within this time (10s), the STFPC311 will put the system into standby mode again by setting STBY to logic high.

If READY is detected as logic high, the watchdog timer will be turned OFF. The main processor should program the remote control hot key and initialize the other parameters of the STFPC311 in preparation for normal operation before the system goes into standby mode. After all of the STFPC311 configuration is finished, the host processor may set the READY to low so that the STFPC311 enters standby mode. The STFPC311 then sets the MUTE pin to logic high to mute the audio output as well as the STBY pin to logic high. As a consequence of this action, the main supply voltage is turned off.

3.1 Normal mode of operation

After the power is plugged in, the device will supply power to all of the components (including the host processor) by setting STBY to logic low in order to allow the host processor to program the STFPC311. Once the STBY is set to low, the watchdog timer starts to count up to 10s (10s is the default value of the watchdog timer upon power-up). When the READY is asserted within this time, it indicates that the system has booted up well. If the READY pin is not asserted (logic high) within this time (10s), the STFPC311 will put the system into standby mode again by setting STBY to logic high.

If READY is detected as logic high, the watchdog timer will be turned OFF. The main processor should program the remote control hot key and initialize the other parameters of the STFPC311 in preparation for normal operation before the system goes into standby mode. After all of the STFPC311 configuration is finished, the host processor may set the READY to low so that the STFPC311 enters standby mode. The STFPC311 then sets the MUTE pin to logic high to mute the audio output as well as the STBY pin to logic high. As a consequence of this action, the main supply voltage is turned off.

3.2 Receive operation

In receive condition, the STFPC311 waits for a valid command from the MCU. The receive circuit of STFPC311 receives 8 bit serial data, latches the data and then masks the inputs from the MCU. Refer to [Figure 30 on page 32](#) for receive timing.

3.3 Transmit operation

In transmit condition, the STFPC311 sends the 8-bit serial data (LSB transmitted first) whenever a key is pressed or IR data is received. STFPC311 transmits data on the falling edge of CLK. Refer to [Figure 31 on page 32](#) for transmit timing.

3.4 Standby or power-down mode

Once the STFPC311 detects the status change of the READY to a logic low or after the preset waiting time (1s to 15s) has elapsed, the STFPC311 sets the STBY pin to a logic high to turn off the power. The MUTE signal is set to high before the power is turned off. The STFPC311 always senses the level on the READY pin during normal operation.

3.5 IR decoding

Encoded IR data from photodiode is supplied to the IR_DATA_IN input pin. The data is decoded by the internal remote control decoder module of STFPC311. In standby mode, the remote control decoder recognizes a set of predefined commands (such as STANDBY, PLAY, and OPEN/CLOSE), and takes appropriate action to manage the power supply.

These predefined commands are known as "hot keys" and are programmable. The decoded IR commands are passed on to the main processor through the SPI interface by sending 3 bytes of data on the D_{OUT} pin.

3.6 Watchdog timer

The watchdog timer is used to detect an out-of-control microprocessor. The watch dog timer is implemented in the STFPC311 to detect the abnormal processor behavior or processor-hung condition. The default state of the watchdog timer is 10s when the device powers-up. It is initialized by writing to the watchdog register and can be programmed to up to 15s (4-bit watchdog timer, present in the configuration mode setting command).

If the processor does not reset the timer within the specified period, the STFPC311 will put the entire system into standby mode to reset the appliance that has stopped abnormally. The action to take when the watchdog timer has reached its count is to set the Watchdog Action register. The watchdog timer can be reset by the host processor by sending a command to reset the watchdog timer. The time-out period then starts over again. If the processor needs to be reset as a result of a hung condition (signalled using the STBY output of the STFPC311), the watchdog timer uses the amount of the time-out programmed into the Watchdog Register by the user to generate an interrupt.

Note: The accuracy of the timer is within $\pm 10\%$ the selected resolution. This depends on the value of the external bias resistor, as it determines the internal clock frequency.

The watchdog function is automatically set to 10s upon power-up and the Watchdog Interrupt is cleared. This boot-up watchdog timer is used to make sure that if the host processor hangs during the first boot-up, the STFPC311 will put the system to standby mode. During the first boot-up, the watchdog timer is disabled after the first READY signal is received.

3.6.1 Watchdog timer operation during power-up

Figure 3. Power-up condition

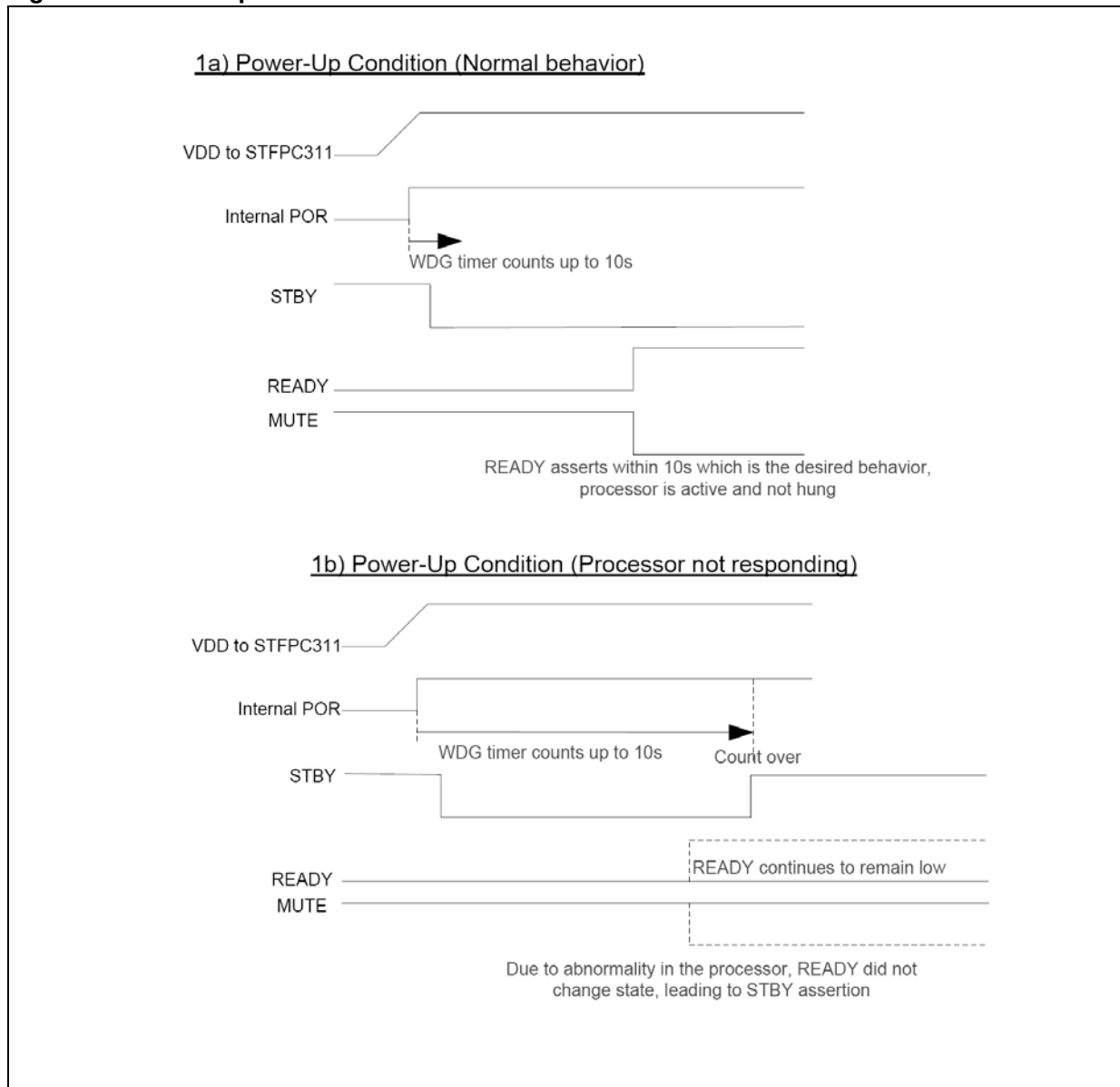

Note: Watchdog timer is turned off by default upon READY assertion.

If Watchdog is to be kept on during READY high condition, the WDG registers must be set accordingly by proper commands through SPI bus.

In this power-up condition, the watchdog timer is triggered by internal POR pulse.

During power-up, the watchdog timer value is 10 s.

3.6.2 Watchdog timer operation during power-down

Figure 4. Power-down condition

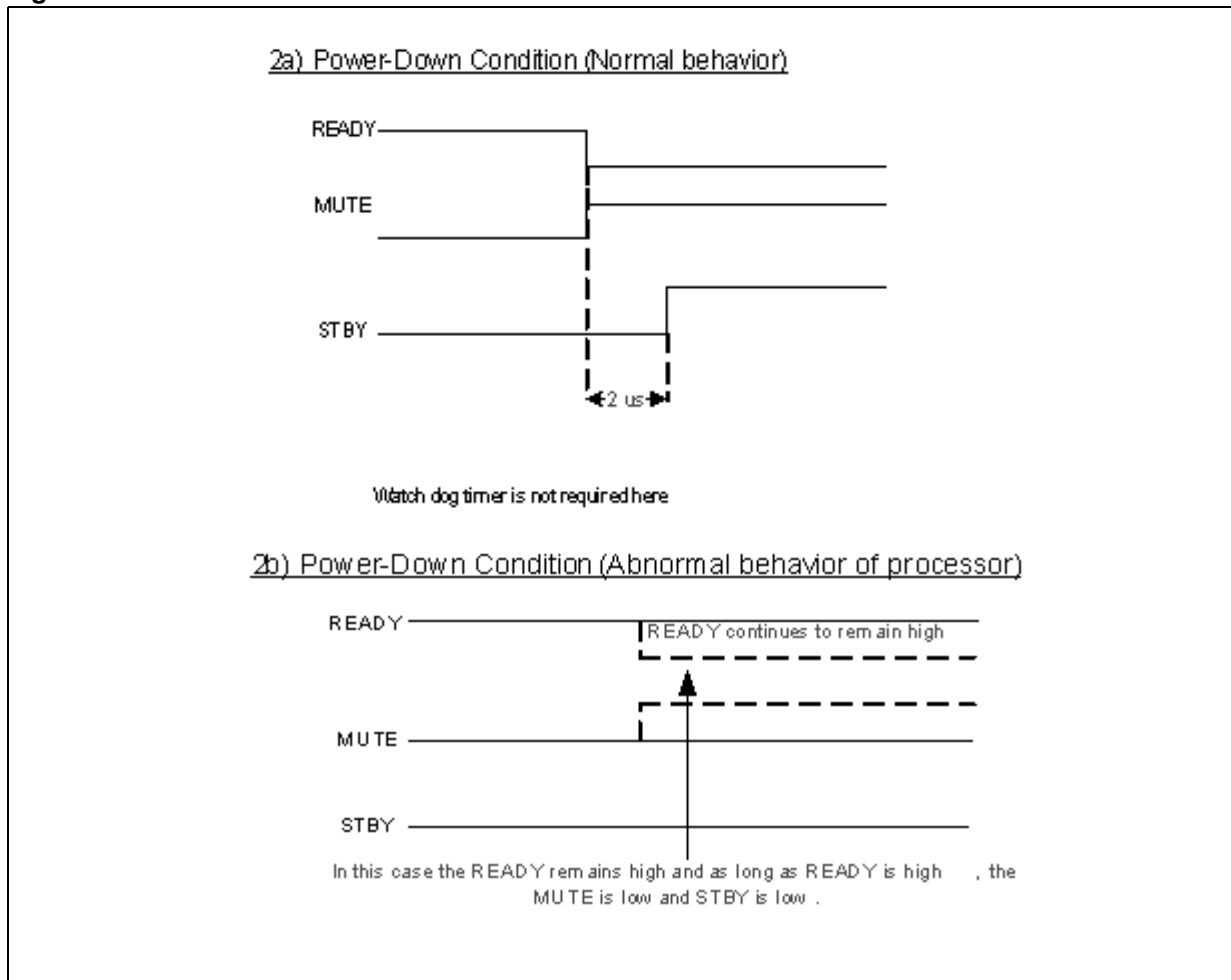

Note: The watchdog timer can be kept on during normal conditions when READY is high (depending on the user's settings).

In this condition, the watchdog timer can be disabled or enabled. If the watchdog timer is enabled, the timer needs to be cleared before the programmed count of the timer is reached. If the programmed count is reached, the STBY will be asserted.

Caution: It is advisable not to enable the watchdog timer during normal operation.

3.6.3 Watchdog timer operation during standby

- When a hot-key signal is detected either from the front panel or remote control during standby, the STBY de-asserts.
- The de-assertion of the STBY triggers the watchdog timer.
- The timer value is the programmed value that is set by the user (1s-15s). If the user did not change the value before entering standby, then it remains 10s.
- Also note: that The watchdog timer is off when the STFPC311 is in the standby mode to save power.

Figure 5. Standby condition

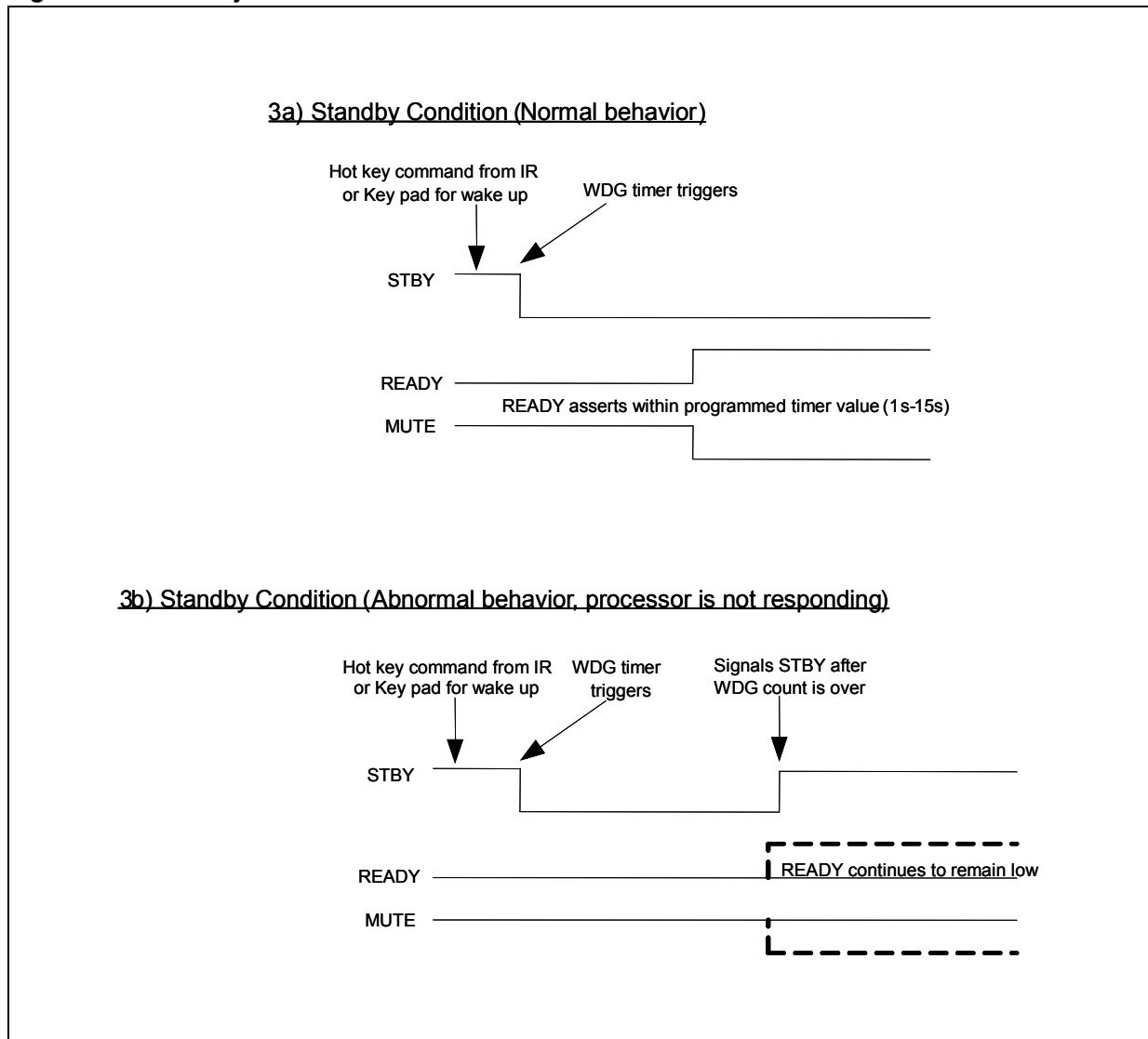

The watchdog timer is triggered by a de-assertion of the STBY signal or by the internal Power-on Reset signal. It is not affected by the STB pin.

3.7 Flowcharts

Figure 6. Timing power standby sequencer flowchart

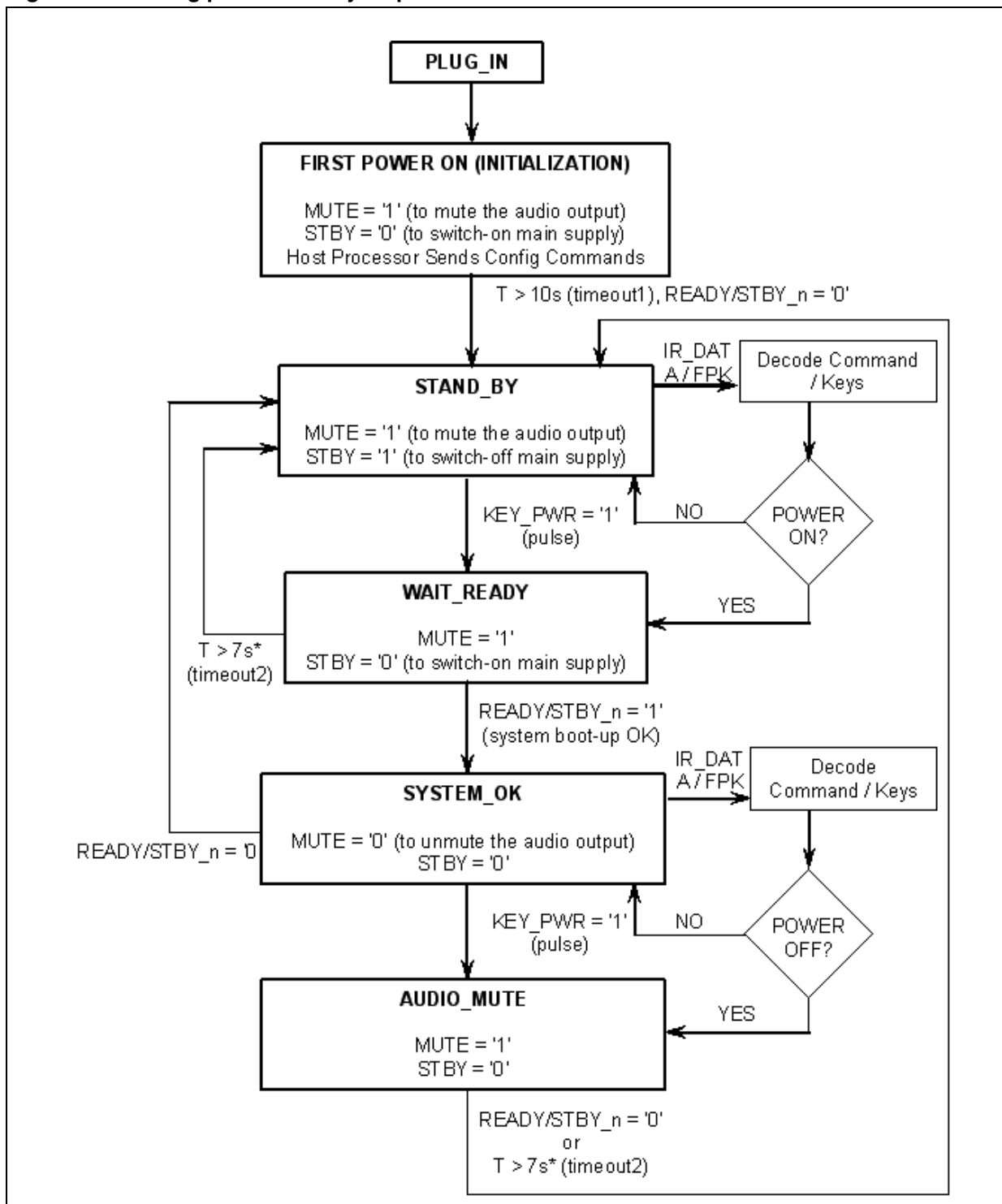

* Programmable from 1 to 15s.

† FPK = Front Panel Keys

Figure 7. IR RC command and front panel key operation flowchart

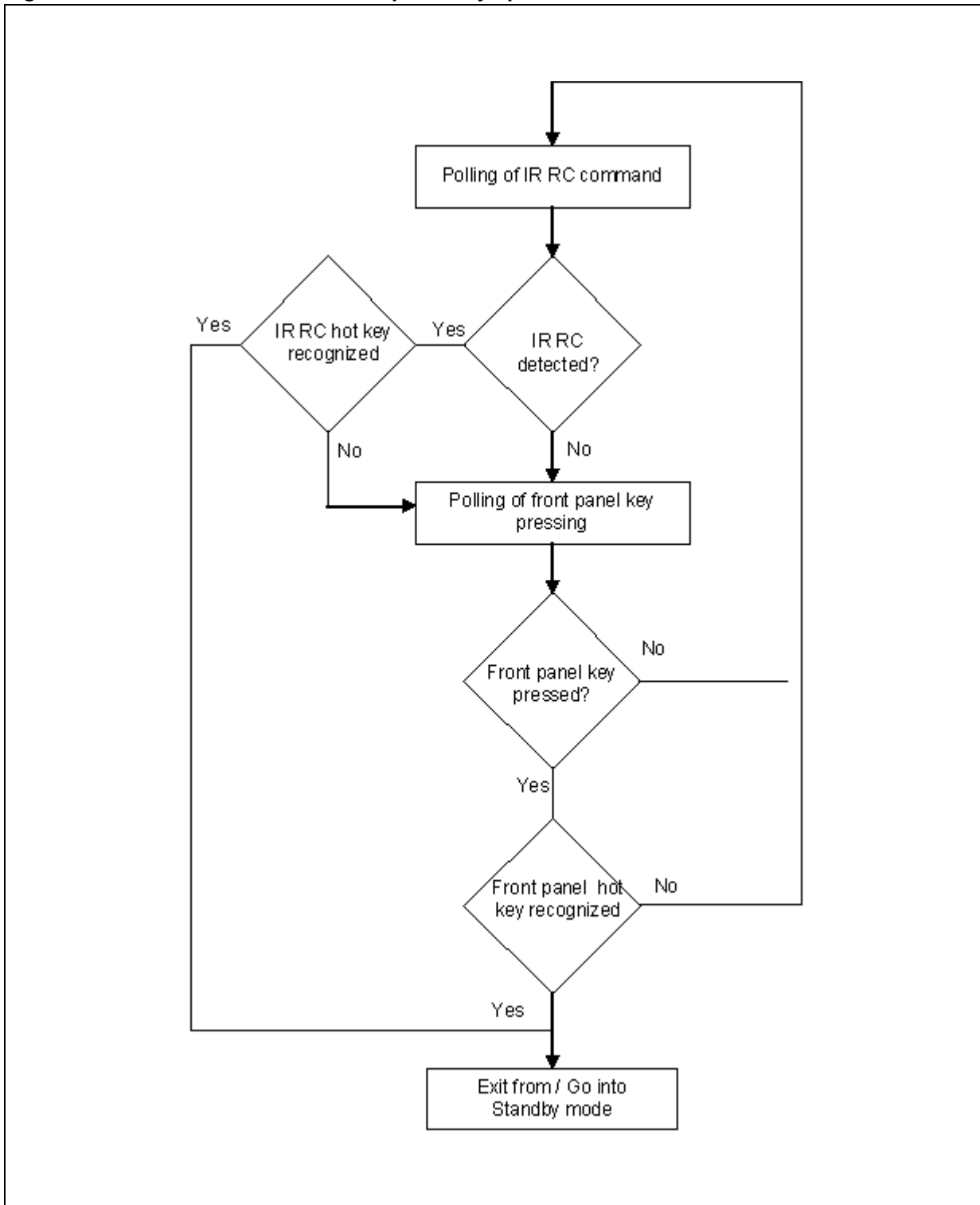

Figure 8. Watchdog timer first power-up operation

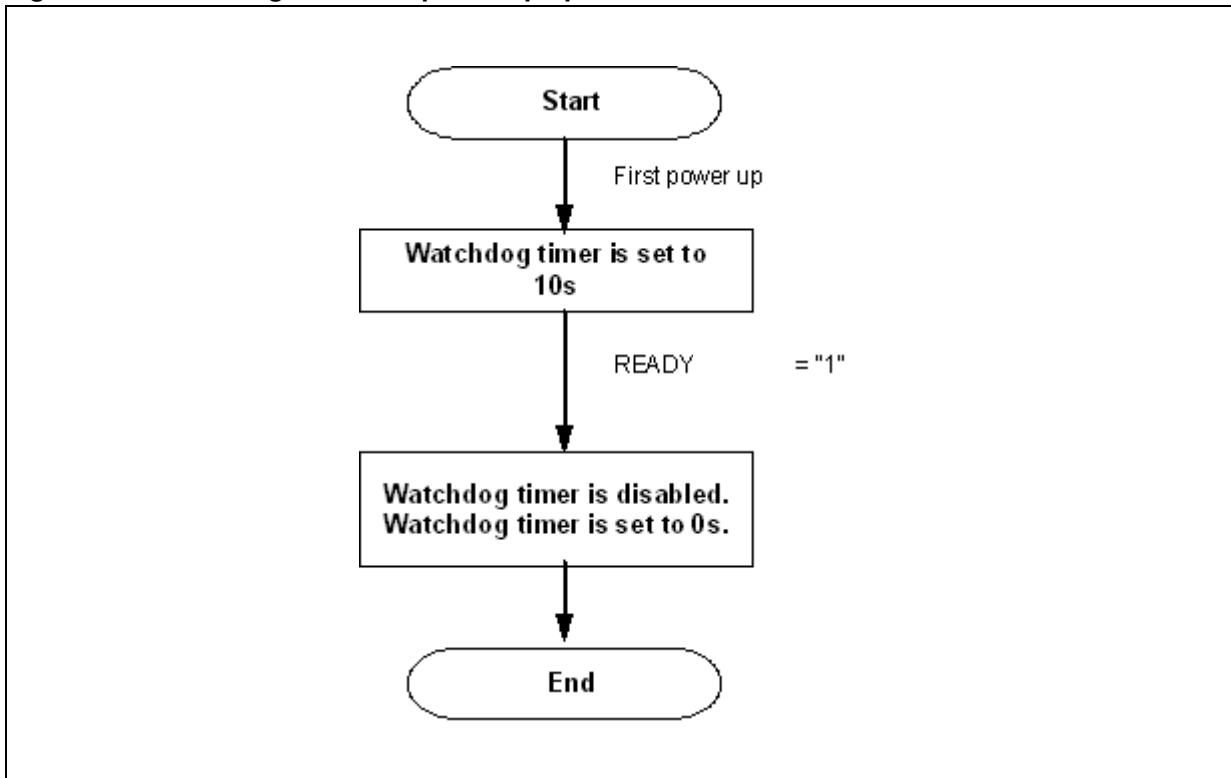
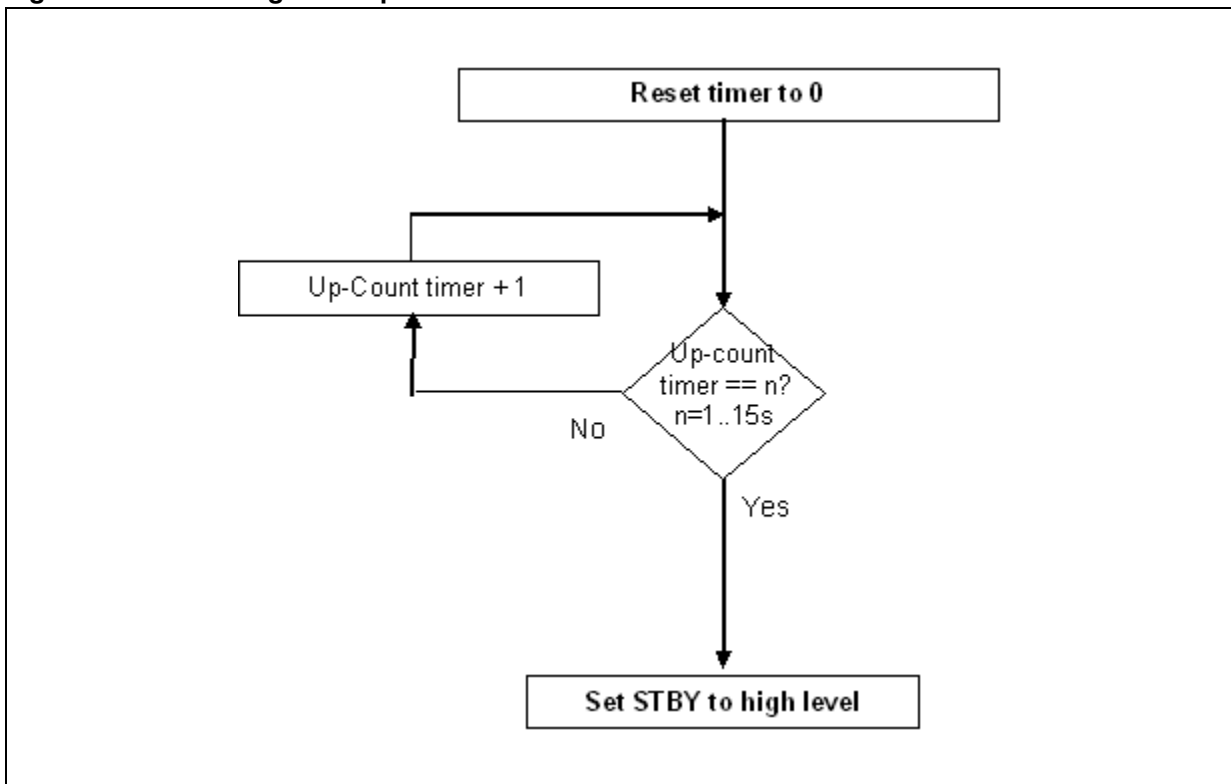

Figure 9. Watchdog timer operation



4 Display RAM address and display mode

The display RAM stores the data transmitted from an external device to the STFPC311 through the serial interface and is assigned addresses, in units of 8-bits see [Table 3](#).

Only the lower 4 bits of the addresses assigned to Seg₁₇ through Seg₂₀ are valid, the higher 4 bits are ignored.

Note: The common grid/segment outputs are grid-based. The grid has to be enabled before any segments can be turned on. If data is written for a segment before enabling its grid, there is nothing on the display.

Table 3. Assigned addresses

Seg ₁	Seg ₄	Seg ₈	Seg ₁₂	Seg ₁₆	Seg ₂₀
00 H _L	00 H _U	01 H _L	01 H _U	02 H _L	DIG ₁
03 H _L	03 H _U	04 H _L	04 H _U	05 H _L	DIG ₂
06 H _L	06 H _U	07 H _L	07 H _U	08 H _L	DIG ₃
09 H _L	09 H _U	0A H _L	0A H _U	0B H _L	DIG ₄
0C H _L	0C H _U	0D H _L	0D H _U	0E H _L	DIG ₅
0F H _L	0F H _U	10 H _L	10 H _U	11 H _L	DIG ₆
12 H _L	12 H _U	13 H _L	13 H _U	14 H _L	DIG ₇
15 H _L	15 H _U	16 H _L	16 H _U	17 H _L	DIG ₈
18 H _L	18 H _U	19 H _L	19 H _U	1A H _L	DIG ₉
1B H _L	1B H _U	1C H _L	1C H _U	1D H _L	DIG ₁₀
1E H _L	1E H _U	1F H _L	1F H _U	20 H _L	DIG ₁₁
21 H _L	21 H _U	22 H _L	22 H _U	23 H _L	DIG ₁₂
24 H _L	24 H _U	25 H _L	25 H _U	26 H _L	DIG ₁₃
27 H _L	27 H _U	28 H _L	28 H _U	29 H _L	DIG ₁₄
2A H _L	2A H _U	2B H _L	2B H _U	2C H _L	DIG ₁₅
2D H _L	2D H _U	2E H _L	2E H _U	2F H _L	DIG ₁₆
b ₀	b ₃ b ₄	b ₇			
XX H _L	XX H _U				
Lower 4 bits	Higher 4 bits				

The data of each key is stored READ by a read command, starting from the least significant bit, see *Figure 11*.

When the most significant bit of data (Seg₁₂b₇) has been read, the least significant bit of the next data (Seg₁b₀) is read.

Figure 10. Key matrix (12 x 2 configuration) and key-input data storage RA

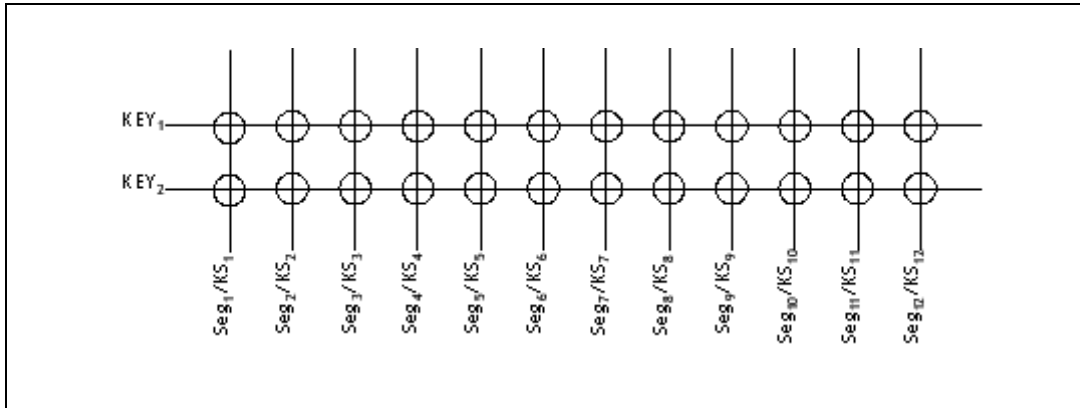
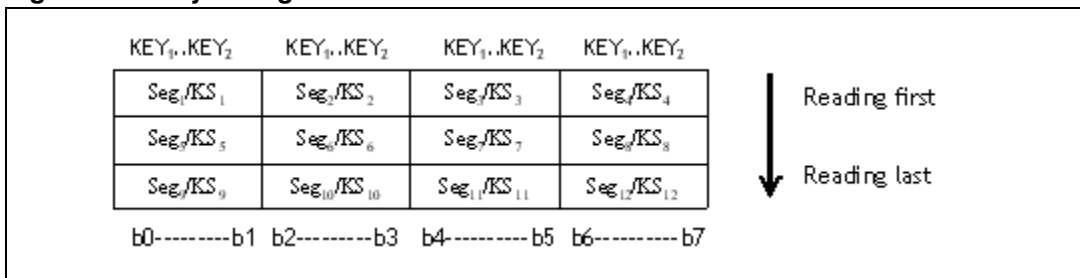

Figure 11. Key storage and READ access



5 Data

5.1 LED port

Data is written to the LED port by a WRITE command, starting from the least significant bit of the port see [Figure 12](#). When a bit of this port is set to 0, the corresponding LED lights up; when the bit is set to a 1, the LED turns off. The data of bits 5 through 8 are ignored. Upon first power-up, all of the LEDs are turned off.

Figure 12. LED port data WRITE command order

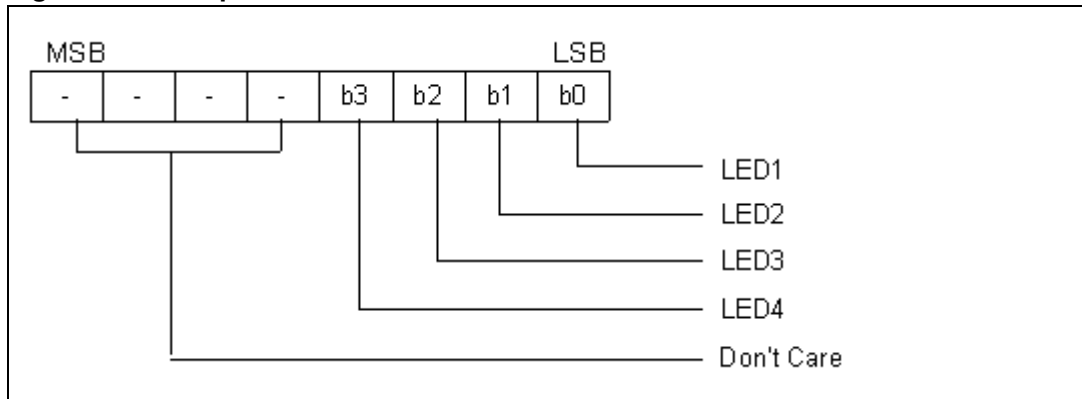

5.2 SW data

The SW data are read by the appropriate READ command, starting from the least significant bit, see [Figure 13](#). Bits 3 through 8 of the SW data are 0.

Figure 13. SW data READ command order

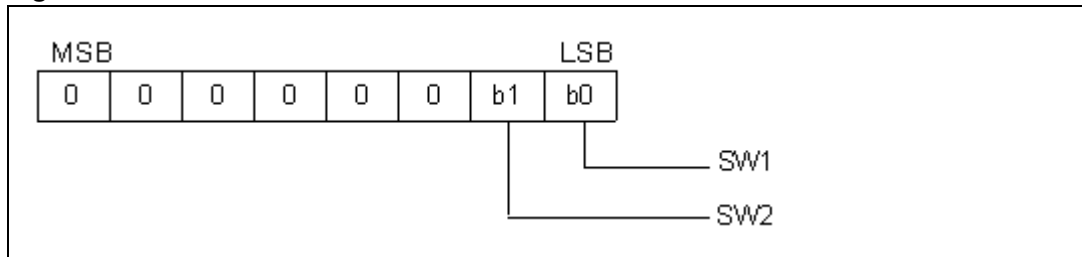

6 Commands

A command sets the display mode and status of the VFD driver. The first 1-byte input to the STFPC311 through the D_{IN} pin after the STB pin goes low is regarded as a command. If STB is set to high while commands/data are transmitted, the serial communication is initialized and the commands/data being transmitted are invalid (however, the commands/data already transmitted remain valid).

6.1 Configuration mode setting command

This command initializes the STFPC311 and performs any one of the following functions see [Figure 14](#).

- a) Selects the number of segments and number of grids (1/8 to 1/16 duty, 12 segments to 20 segments). When this command is executed, the display is turned off. To resume display, the Display ON command must be executed. If the same mode is selected, nothing is performed.
- b) Selects the remote control protocol to use.
- c) Sets the watchdog timer. The watchdog timer is configurable from 1s to 15s or turned off completely.
- d) Sets the watchdog action to perform when the watchdog timer counts. Two actions are allowed: no action, and set STBY to (logic) high level.

Figure 14. STFPC311 configuration mode setting command order

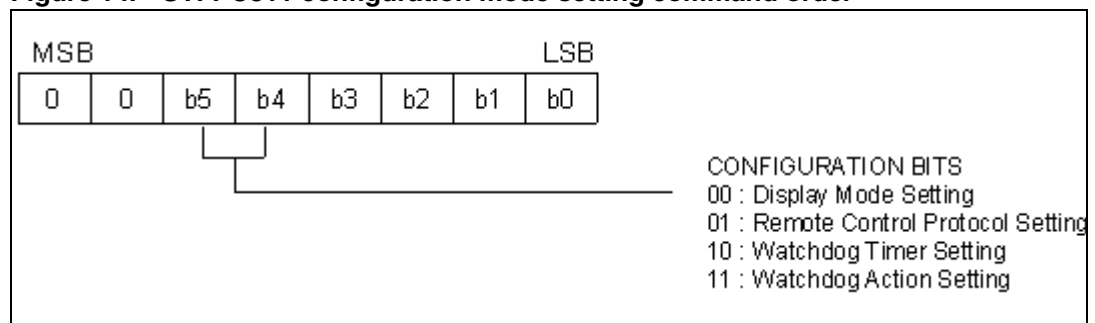

Figure 15. STFPC311 configuration mode bit 3 through bit 0 settings

<p>DISPLAY MODE SETTING 0XXX : 8 digits, 20 segments 1000 : 9 digits, 19 segments 1001 : 10 digits, 18 segments 1010 : 11 digits, 17 segments 1011 : 12 digits, 16 segments 1100 : 13 digits, 15 segments 1101 : 14 digits, 14 segments 1110 : 15 digits, 13 segments 1111 : 16 digits, 12 segments</p>	<p>REMOTE CONTROL PROTOCOL SETTING 0000 : RC Disable 0010 : RC-5 0011 : RC-6 0100 : NEC</p>	<p>WATCHDOG TIMER SETTING 0000 : Turned off 0001 : 1 seconds 1111 : 15 seconds xxxx : No. of seconds in BCD format</p>	<p>WATCHDOG ACTION SETTING 0000 : No action 0001 : Issue STANDBY</p>
---	--	---	---

Note: Based on bit 5 through bit 4 settings.

Upon power application, the following modes are selected:

- Display Mode Setting: the 16-digit, 12-segment mode is selected (default: display off and key-scan on).
- Remote Control Protocol Setting: RC-5.
- Watchdog Timer Setting: Turned on with 10s. After the first command is processed by STFPC311, the watchdog timer is turned off until it is turned on by the host.
- Watchdog action: Issue Standby.

6.2 Data setting command

This command sets the data WRITE and READ modes see [Figure 16](#).

Figure 16. STFPC311 data setting command order

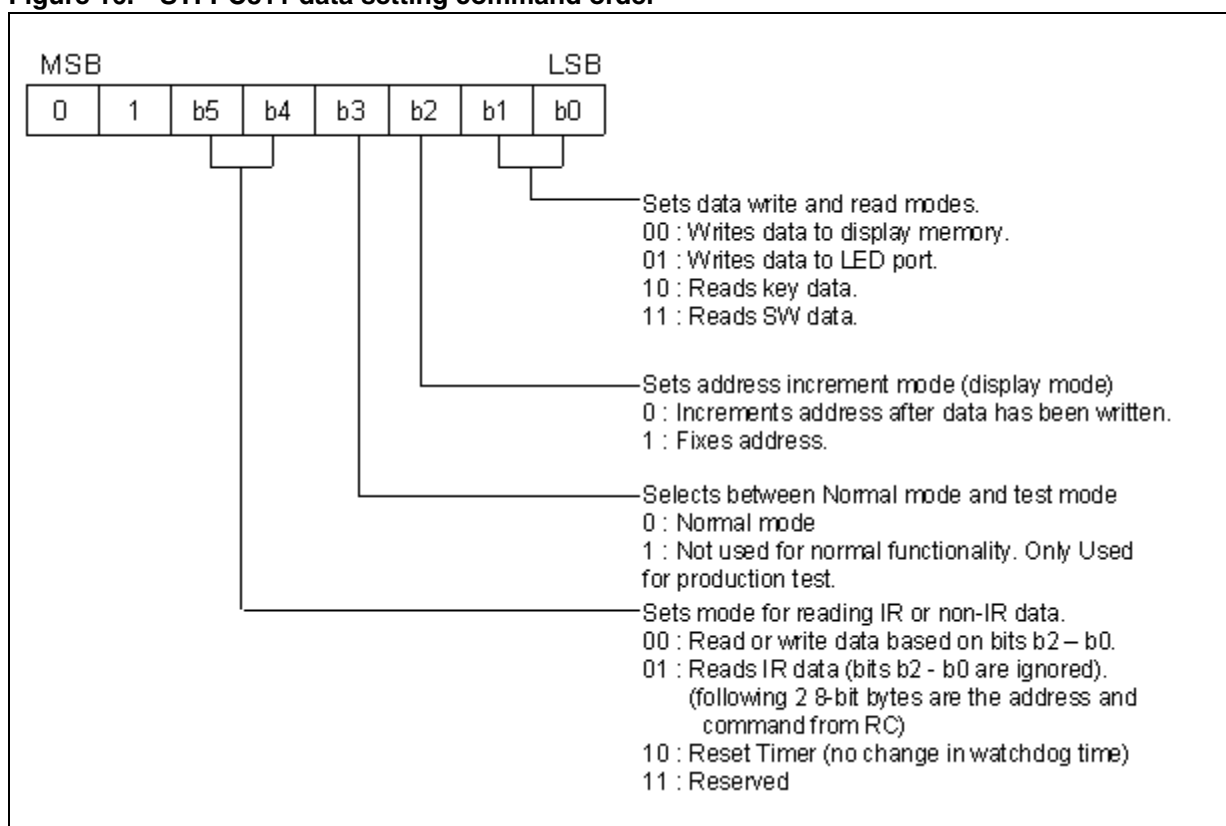

When the application is powered-up, the normal operation mode and address increment mode is set with the default display memory address set to 00H. In the auto-increment address mode, the address command is sent once, followed by the data bytes.

Alternatively, the data command can be sent, followed by the data bytes. In this case, when new display data is to be written, the last value of the address will be used and then incremented. Upon reaching the last display memory address, the address jumps to 00H.

For fixed address mode, the address command has to be sent, followed by the display data. When next byte of data is to be written, the address command has to be sent again before the new display data byte.

For RC-5 data reception (after the photodiode), a binary 1 is represented by a high-to-low transition, and a binary 0 is represented by a low-to-high transition. For RC-6 (Mode 0) data reception, a binary 1 is represented by a low-to-high transition, and a binary 0 is represented by a high-to-low transition. Whenever bit 5 is a '1', the watchdog timer is reset.

6.3 Address setting command

This command sets an address of the display memory. If address 30H or higher is set, the data is ignored until a correct address is set.

Figure 17. STFPC311 address setting command order

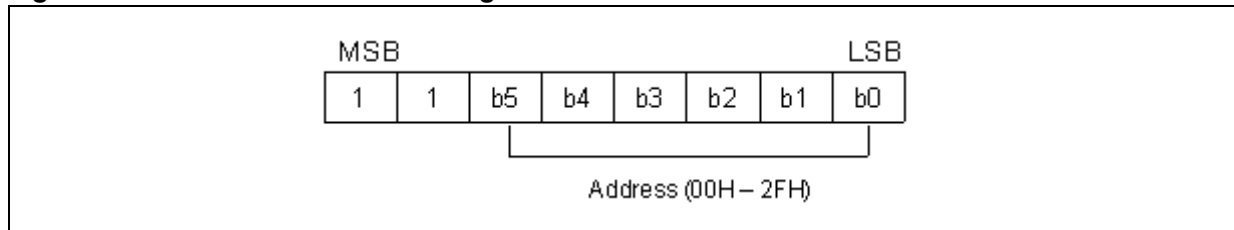

6.4 Display control and hotkey setting command

When the application is powered-up, the 1/16-pulse width is set and the display is turned OFF.

See [Figure 18](#) and [Figure 4](#). All hot keys are disabled.

Figure 18. STFPC311 display control and hot key setting command order

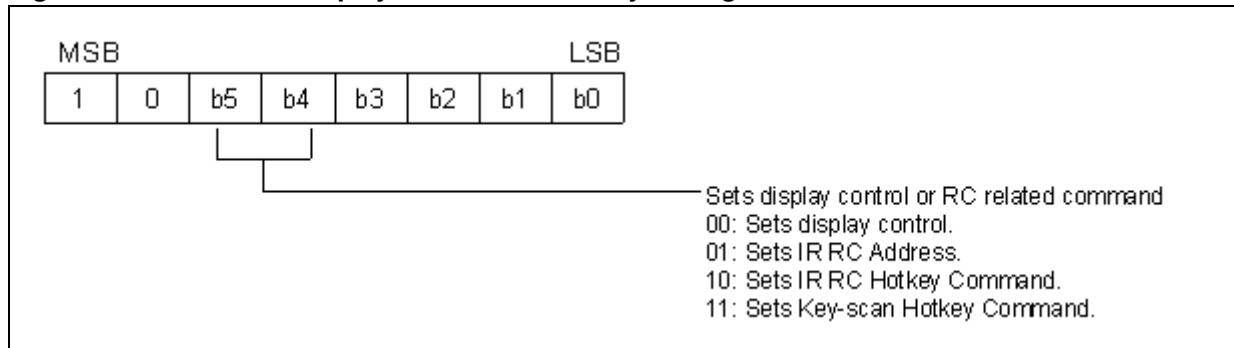

Figure 19. STFPC311 address setting mode bit 3 through bit 0 settings

<p>When b5 b4 = 0 0</p> <p>b2..b0 : Sets dimming quantity. 000 : Sets pulse width to 1/16. 001 : Sets pulse width to 2/16. 010 : Sets pulse width to 4/16. 011 : Sets pulse width to 10/16. 100 : Sets pulse width to 11/16. 101 : Sets pulse width to 12/16. 110 : Sets pulse width to 13/16. 111 : Sets pulse width to 14/16.</p> <p>b3 : Turns on/off display 0 : Display off (key scan continues*) 1 : Display on</p>	<p>When b5 b4 = 0 1</p> <p>b3..b0 : Don't care</p> <p>Following 8-bit is sent to indicate the address for RC.</p>	<p>When b5 b4 = 1 0</p> <p>b3..b0 : Address for storing hotkeys 0000 : Location 1 for RC command : : 0111 : Location 8 for RC command</p> <p>When b5 b4 = 1 1</p> <p>0000 : Location 1 for FPK1 command 0001 : Location 2 for FPK2 command 0010 : Location 3 for FPK3 command</p> <p>Following 8-bit is sent to indicate the RC hotkey to be stored into internal memory *FPKx = Front Panel Key Set x. See next page</p>
---	---	---

7 Programmable hotkeys

7.1 IR Remote control

Eight (8) commands are user programmable for hot key functions.

The address of the appliance (8-bit) is stored first into the internal RAM. Then, the command for the hot keys are programmed into the internal RAM. Each hot key memory address could accommodate one byte (8-bits). Usually one byte is reserved for one command. The RC data is only cleared when the READY is pulled low (system goes into STANDBY state).

7.2 Front panel keys

Eight out of 24 keys are user programmable for hot key functions. Only keys from KS1 to KS4 can be programmed.

Figure 20. Programmable hot keys (only KS1 to KS4, Box FPK1)

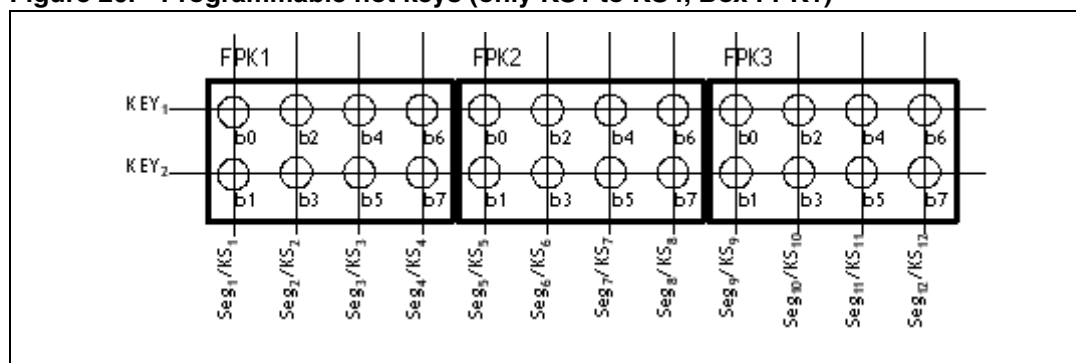

8 hot keys are to be placed in each address location as indicated by the hotkey setting command.

Figure 21. HOTKEY setting command address locations (8 hot keys)

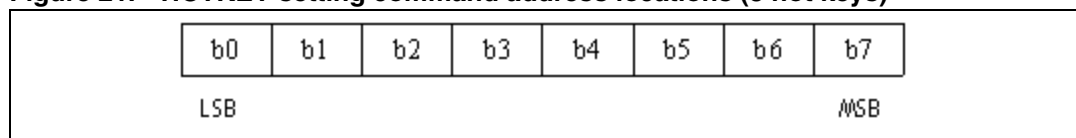

For example, to store (Seg2/Key2) at the first location of the hot key RAM, the following commands are sent:

- 10110000 (command+address), and
- 00010000 (hot key mask).

To store (Seg2/Key1), (Seg2/Key2), and (Seg4/Key1), the following commands are sent:

- 10110000 (command+address), and
- 00110010 (hot key mask).

The same commands apply to FPK2 and FPK3 programming.

Note: Reading the hot key values immediately upon STBY de-assertion is recommended. If they are not read within the watchdog preset timer value, the hot key data is cleared.

Figure 22. Recommended software flow

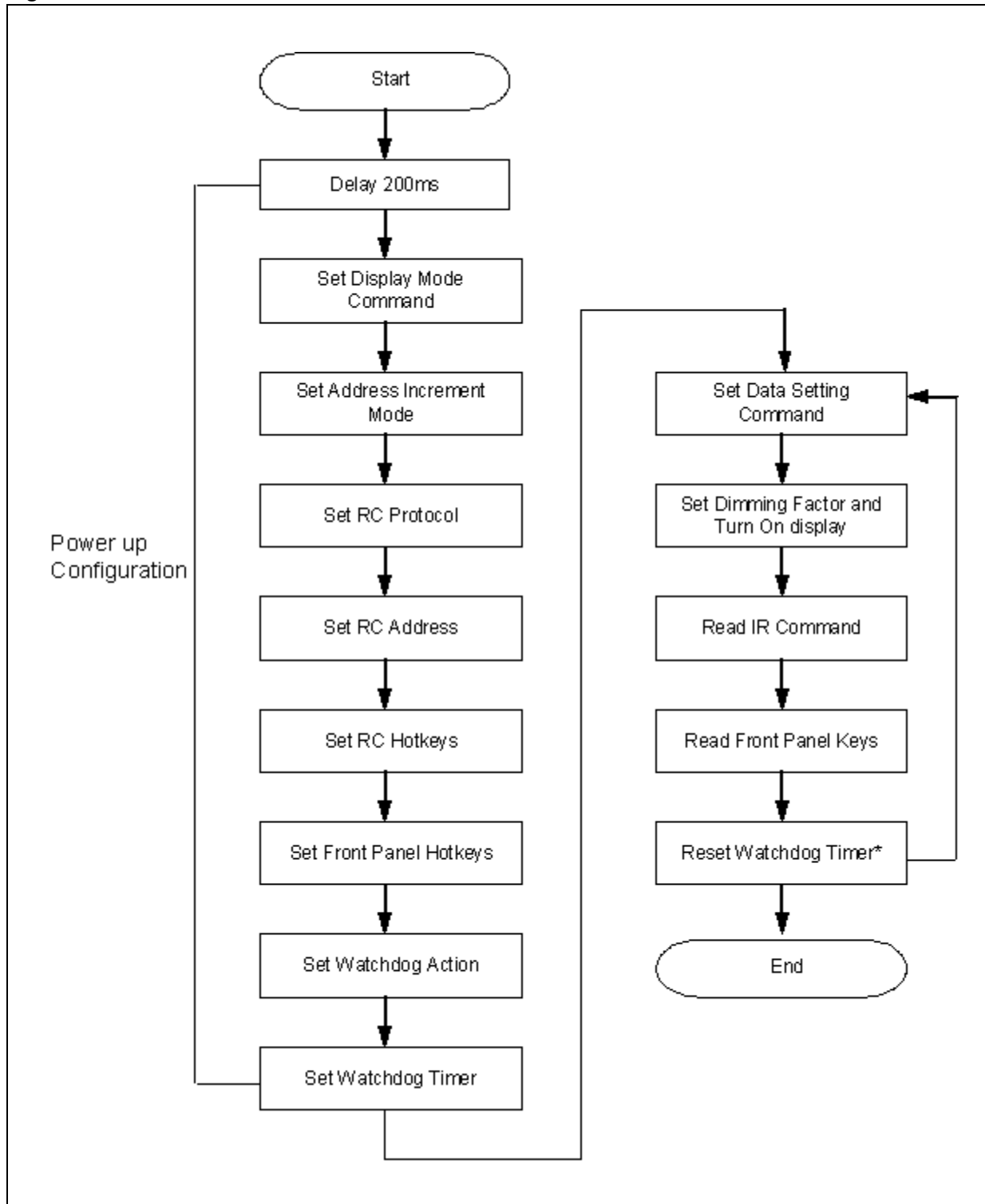

Note: Resetting the front panel controller at $\frac{3}{4}$ of the set watchdog time is recommended.

8 Default status

8.1 Power-up default status

Table 4. Default states

S. N°	Functions	Default status
1	Display	OFF
2	Key-scan	ON
3	IR	ON
4	Display mode	12 Seg/16Bit
5	Display address	00H
6	RC Protocol	DC-5
7	LED	OFF
8	Dimming	1/16 Duty factor
9	Hot Kets (IR and FP)	Disabled
10	Watchdog timer	10s

8.2 STANDBY status

The display remains ON during STANDBY only if the -20V is present. If the -20V is absent, the display turns OFF. When the display wakes up from STANDBY and -20V is applied, the display turns ON with previous value.

Switching off the display before entering the STANDBY state is recommended.

When the same display configuration command is sent, the display remains ON. When the display configuration command is changed, the display is OFF.

Only hot key detection can wake the system up from STANDBY condition.

9 Remote control protocols

9.1 RC-5 remote control

RC-5 remote control protocol is based on Bi-phase (also known as Manchester) encoding as shown in [Figure 23](#).

Note: The encoding is set with reference to the IR_DATA_IN signal (after the photo diode). The MSB is transmitted first see [Figure 24](#).

- The first two Start bits (S1 and S2) are synchronization bits. For normal operation, they are always set to '11' on the transmission side. After the photo diode, there is one inversion. The data at the IR_DATA_IN of the STFPC311 is shown in [Figure 25 on page 26](#)
- The next bit is the Toggle bit. This bit is inverted each time a key on the remote control is pressed.
- Bits A1 and A5 are the Address bits. The address bits indicate the intended application that the remote control protocol is used for.
- Bits C1..C6 are the Command bits. The command bits instruct the STFPC311 as to what action is to be taken. The data representing the RC-5 protocol is sent as a byte of data which consists of a Toggle bit and a '0' bit followed by 6 bits of Command data.

Figure 23. Bi-phase encoding

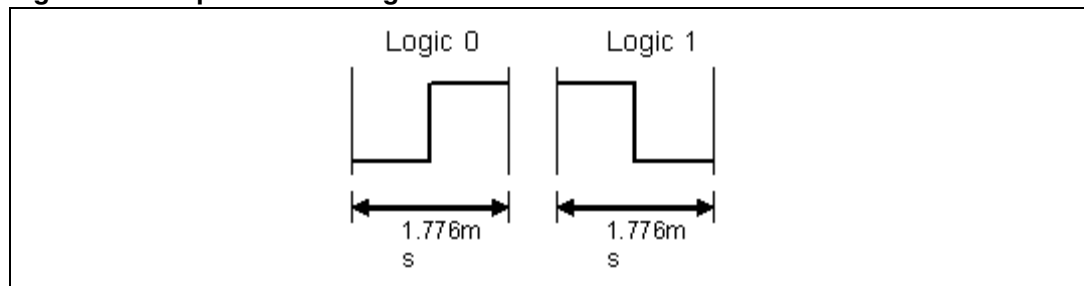

Figure 24. RC-5 protocol frame

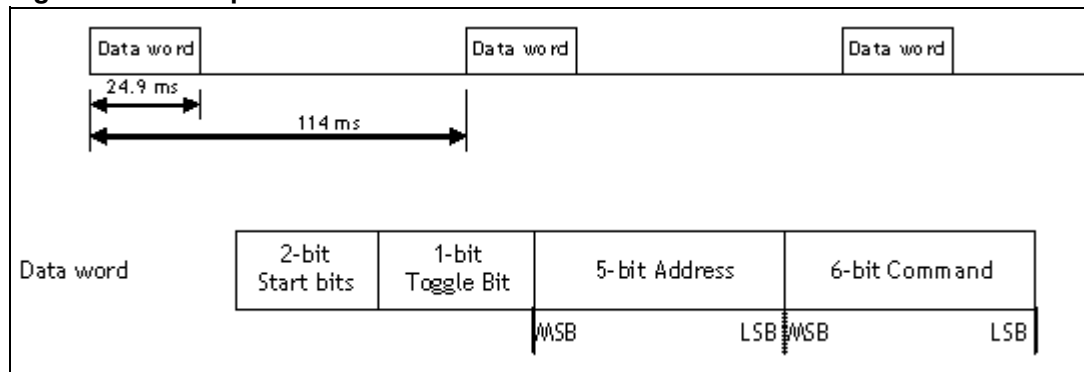
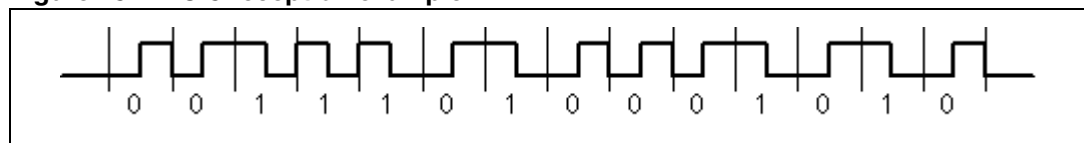

Figure 25. RC-5 reception example



9.2 SPI interface IR data transmission

The IR data is sent on the DOUT pin of the SPI interface when the micro controller issues a IR data read command. The data is sent in 3 bytes with LSB transmitted first as shown in the Figure below:

The RC data consists of RC address, start bit, toggle bit and the RC command received. The extra bits are stuffed with 1's to make it a 3-byte packet. These extra bits at the end of the packet should be ignored.

Figure 26. RC-6 protocol frame

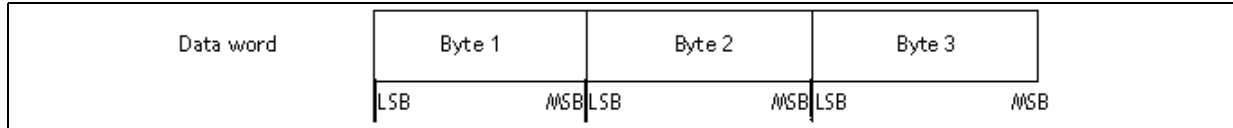

The RC data consists of RC address, start bit, toggle bit and the RC command received. The extra bits are stuffed with 1's to make it a 3-byte packet. These extra bits at the end of the packet should be ignored.

9.3 NEC remote control

This remote control protocol uses pulse distance modulation. Each bit consists of a high level of fixed time "t", followed by a low level that varies in width. A space that is "t" represents a logic '0' and a space that is "3t" represents a logic '1'. t = 0.56ms.

The LSB is transmitted first as shown in Figure 27.

Figure 27. Pulse distance modulation

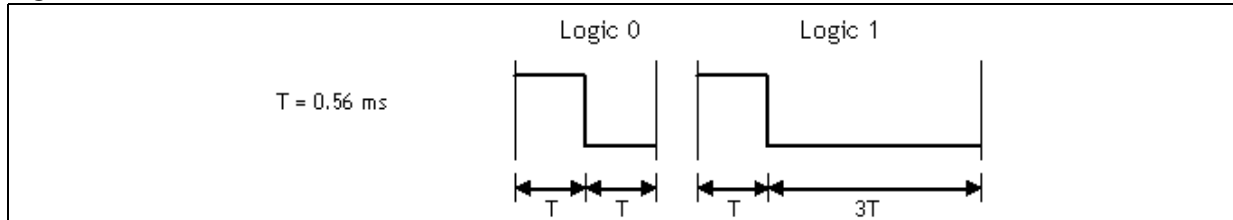
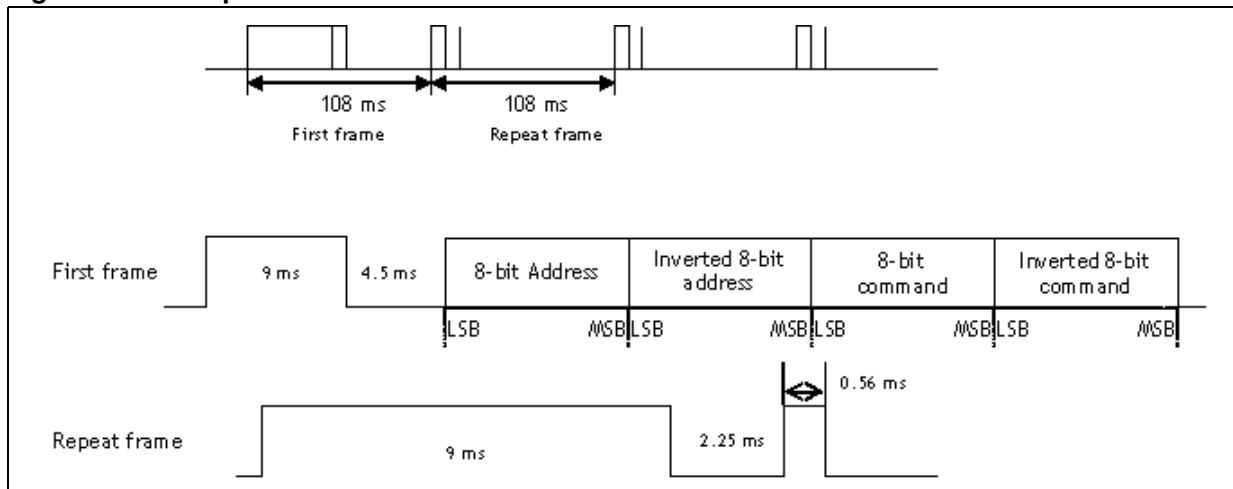

Figure 28. NEC protocol transmission waveforms



10 Maximum rating

Stressing the device above the rating listed in the “Absolute Maximum Ratings” table may cause permanent damage to the device. These are stress ratings only and operation of the device at these or any other conditions above those indicated in the Operating sections of this specification is not implied. Exposure to Absolute Maximum Rating conditions for extended periods may affect device reliability. Refer also to the STMicroelectronics SURE Program and other relevant quality documents.

Table 5. Absolute maximum rating ($T_A = 25\text{ °C}$, $V_{SS} = 0\text{ V}$)

Symbol	Parameter	Value	Unit
V_{DD}	Logic Supply Voltage	-0.5 to +7.0	V
V_{SS}	Driver Supply Voltage	$V_{DD} + 0.5$ to $V_{DD} - 40$	V
V_{I1}	Logic Input Voltage	-0.4 to $V_{DD} + 0.5$	V
V_{O2}	VFP Driver Output Voltage	$V_{SS} - 0.5$ to $V_{DD} + 0.5$	V
I_{O1}	LED Driver Output Current	+25	mA
I_{O2}	VFP Driver Output Current	-40 (grid) -15 (segment)	mA
P_D	Power Dissipation	1200 ⁽¹⁾	mA
T_A	Operating Ambient Temperature	-40 to +85	°C
T_{STG}	Storage Temperature	-65 to +150	°C

1. Derate at -9.6 mW/°C at $T_A = 25\text{ °C}$ or higher

Table 6. Recommended operating conditions ($T_A = -20$ to $+70\text{ °C}$, $V_{SS} = 0\text{ V}$)

Symbol	Parameter	Min	Typ	Max	Unit
V_{DD}	Logic Supply Voltage	3.0	3.3	3.6	V
V_{IH}	High-Level Input Voltage	$0.7V_{DD}$		V_{DD}	V
V_{IL}	Low-Level Input Voltage	0		$0.3 V_{DD}$	V
V_{SS}	Driver Supply Voltage	0		$V_{DD} - 33.3$	V

10.1 Power consumption estimation

The maximum power consumption is comprised of the Vacuum Florescent Display (VFD) driver dissipation, Load Resistance (RL), LED driver dissipation, and dynamic power consumption.

$$P_{MAX} = V_{FD} + R_L + LED + P_{DYN}$$

Where,

- P_{MAX} = maximum power consumption,
- V_{FD} = Vacuum Florescent Display driver dissipation,
- R_L = load resistance,
- LED = LED driver dissipation, and
- P_{DYN} = dynamic power consumption.

If the segment current (I_{SEG}) = 3 mA, grid current (I_{GRID}) = 15 mA, and the LED current = 20 mA, then:

$$FIP = (\#segments \times 6) + [\#grids/(\#grids + 1)] \times 30 \text{ mW},$$

$$R_L \text{ dissipation} = (V_{DD} - V_{SS})^2 \div 50(\text{segment} + 1 \text{ mW}),$$

$$\text{LED driver dissipation} = \#LEDs \times 20 \text{ mW}, \text{ and}$$

$$P_{DYN} = V_{DD} \times 5 \text{ mW}.$$

To finish this example:

$$FIP \text{ driver dissipation} = 16 \times 6 + 12/13 \times 30 = 124\text{mW}$$

$$R_L \text{ dissipation} = 33.32/50 \times 17 = 377 \text{ mW}$$

$$\text{LED driver dissipation} = 2 \times 20 = 40$$

$$P_{DYN} = 3.3 \times 5 = 16.5 \text{ mW}$$

The maximum power consumption (Total) = 557.5 mW

Where,

$$V_{SS} = -30 \text{ V},$$

$$V_{DD} = 3.3 \text{ V}, \text{ and the application is in 16-segment, 12-digit mode.}$$

11 Electrical characteristics

Table 7. Electrical specifications
($T_A = -20$ to $+70^\circ\text{C}$, $V_{DD} = 3.3\text{V}$, $V_{SS} = 0\text{V}$, $V_{SS} = V_{DD} - 33.3\text{V}$)

Symbol	Parameter	Test conditions	Min.	Typ.	Max.	Unit
V_{OH1}	High-Level Output Voltage	LED1 – LED4, $I_{OH1} = -1\text{mA}$	$0.9V_{DD}$			V
V_{OL1}	Low-Level Output Voltage	LED1 – LED4, $I_{OH2} = 20\text{mA}$			1	V
V_{OL2}	Low-Level Output Voltage	D_{OUT} , $I_{OL2} = 4\text{mA}$			0.4	V
I_{OH21}	High-Level Output Current	$V_O = V_{DD} - 2\text{V}$, Seg ₁ to Seg ₁₂	-3			mA
I_{OH22}	High-Level Output Current	$V_O = V_{DD} - 2\text{V}$, Grid ₁ to Grid ₈ , Seg _{13g} /Grid ₁₆ to Seg ₂₀ /Grid ₉	-15			mA
I_{OLEAK}	Driver Leakage Current	$V_O = V_{DD} - 33.3\text{V}$, driver off			-10	μA
R_L	Output Pull-Down Resistor	Driver output	50	100	150	k Ω
I	Input Current	$V_I = V_{DD}$ or V_{SS}			± 1	μA
V_{IH}	High-Level Input Voltage		$0.7V_{DD}$			V
V_{IL}	Low-Level Input Voltage				$0.3V_{DD}$	V
V_H	Hysteresis Voltage	CLK, D_{IN} , STB		0.35		V
$I_{DD(DYN)}$	Dynamic Current Consumption	Under no load, display off			5	mA

Table 8. Switching characteristics ($T_A = -20$ to $+70^\circ\text{C}$, $V_{DD} = 3.3\text{V}$, $V_{SS} = -30\text{V}$)

Symbol	Parameter	Test conditions	Min.	Typ.	Max.	Unit
t_{OSC}	Oscillation Frequency	$R = 33\text{k}\Omega \pm 5\%$	350	500	650	kHz
t_{PLZ}	Propagation Delay Time	CLK \leq D_{OUT} $C_L = 15\text{pF}$, $R_L = 10\text{k}\Omega$			300	ns
t_{PZL}					100	ns
t_{TZH1}	Rise Time	$C_L = 300\text{pF}$	Seg ₁ to Seg ₁₂		2	μs
t_{TZH2}			Grid ₁ to Grid ₈ , Seg _{13g} /Seg ₁₆ to Seg ₂₀ /Grid ₉		0.5	μs
t_{THZ}	Fall Time	$C_L = 300\text{pF}$, Seg _n , Grid _n			120	μs
f_{MAX}	Maximum Clock Frequency	Duty = 50%			1	MHz
C_I	Input Capacitance				15	pF

12 Timing characteristics

Table 9. Timing characteristics
 ($V_{DD}= 3.3\text{ V}$, $T_A= -20\text{ to }70^\circ\text{C}$, unless otherwise noted. Typical values are at $T_A= 25^\circ\text{C}$)

Symbol	Parameter	Test conditions	Values			Unit
			Min.	Typ.	Max.	
PW_{CLK}	Clock Pulse Width		400			ns
PW_{STB}	Strobe Pulse Width		1			μs
t_{SETUP}	Data Setup Time		100			ns
t_{HOLD}	Data Hold Time		100			ns
$t_{CLK-STB}$	Clock-Strobe Time	$CLK \uparrow \rightarrow STB \uparrow$	1			μs
t_{WAIT}	Wait Time ⁽¹⁾	$CLK \uparrow \rightarrow CLK \uparrow$	1			μs

1. Refer to page on Serial Communication Format.

The pulse width of the segment signal is derived from the oscillator frequency. The value can be modified by trimming ROOSC. One cycle of key scanning consists of one frame and data of 12 x 2 matrices are stored in RAM.

Note: The key scan is only at the end of the frame when the display is ON. When the display is OFF, the key scan takes place continuously. The grid is turned off during the key scan.

Figure 29. Key scanning and display timing

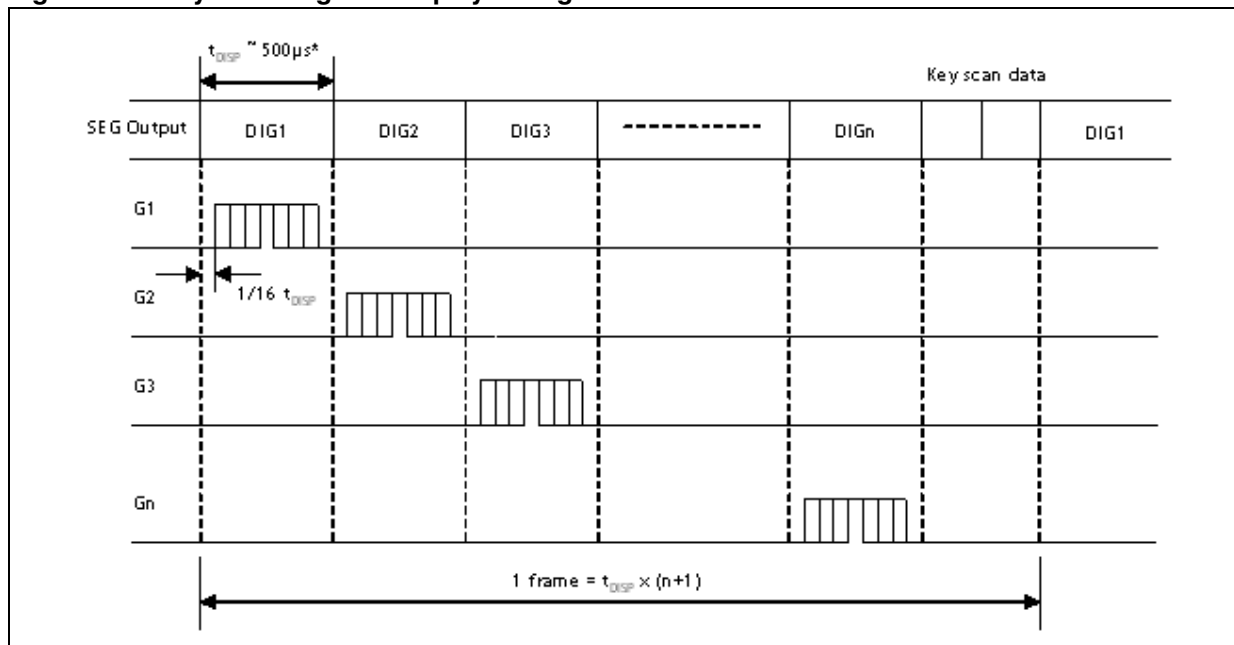

13 Serial communication format

When data is read, a wait time (t_{WAIT}) of 1 μs is necessary within the rising edge of the eighth clock that has set the command, and the falling edge of the first clock that has read the data. This is required by the STFPC311 to process its internal commands/data (See [Figure 30](#))

Caution: Care must be taken to connect an external pull-up resistor to this pin (1 k Ω to 10 k Ω) because the D_{OUT} pin is an N-channel, open drain output pin (see [Figure 31](#)).

Figure 30. Reception (command/data WRITE)

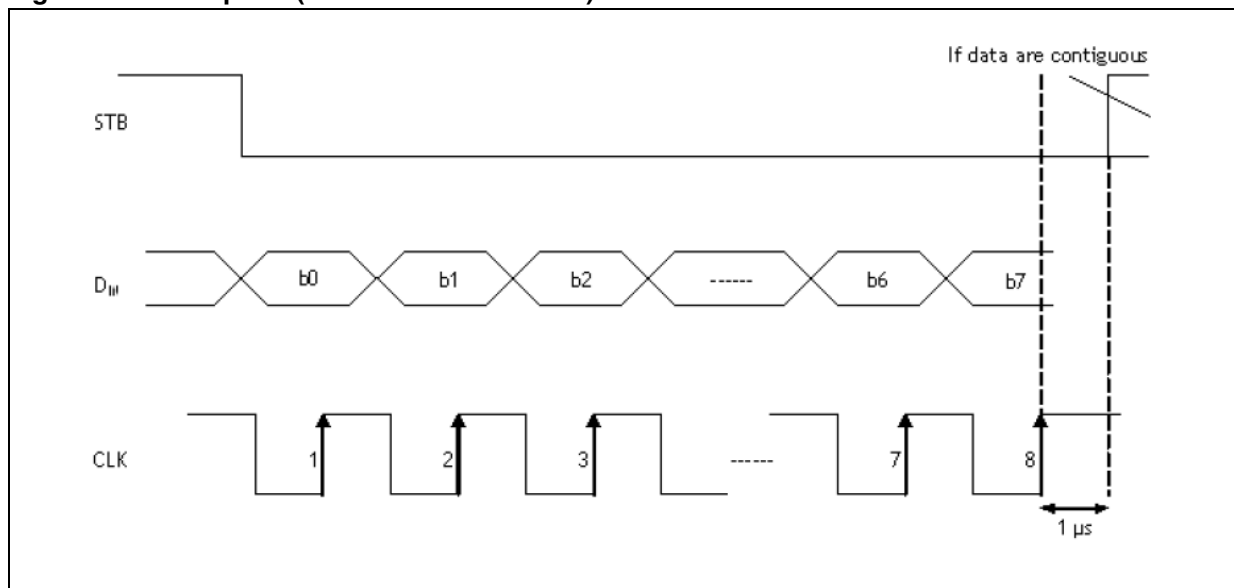

Figure 31. Data transmission (data READ)

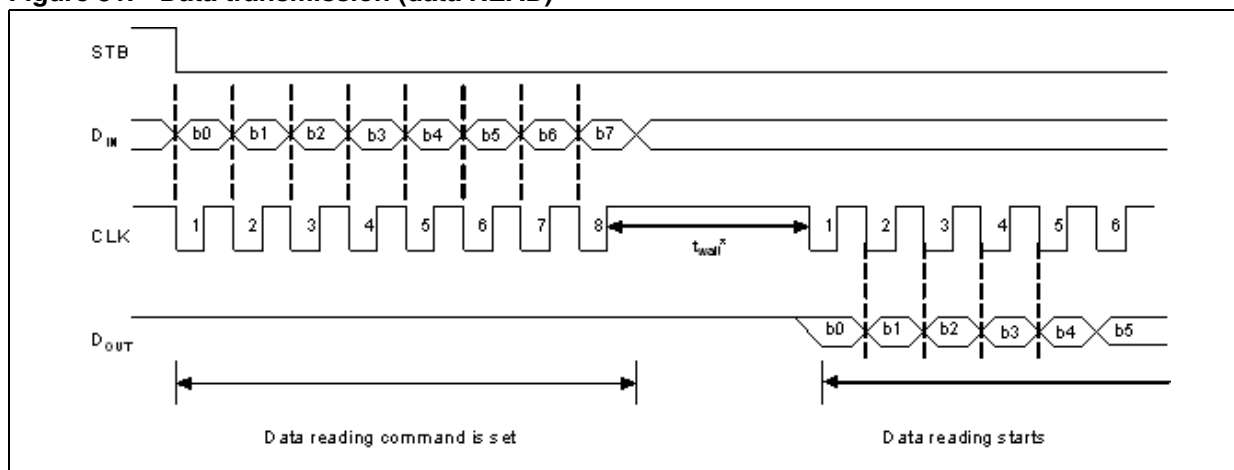
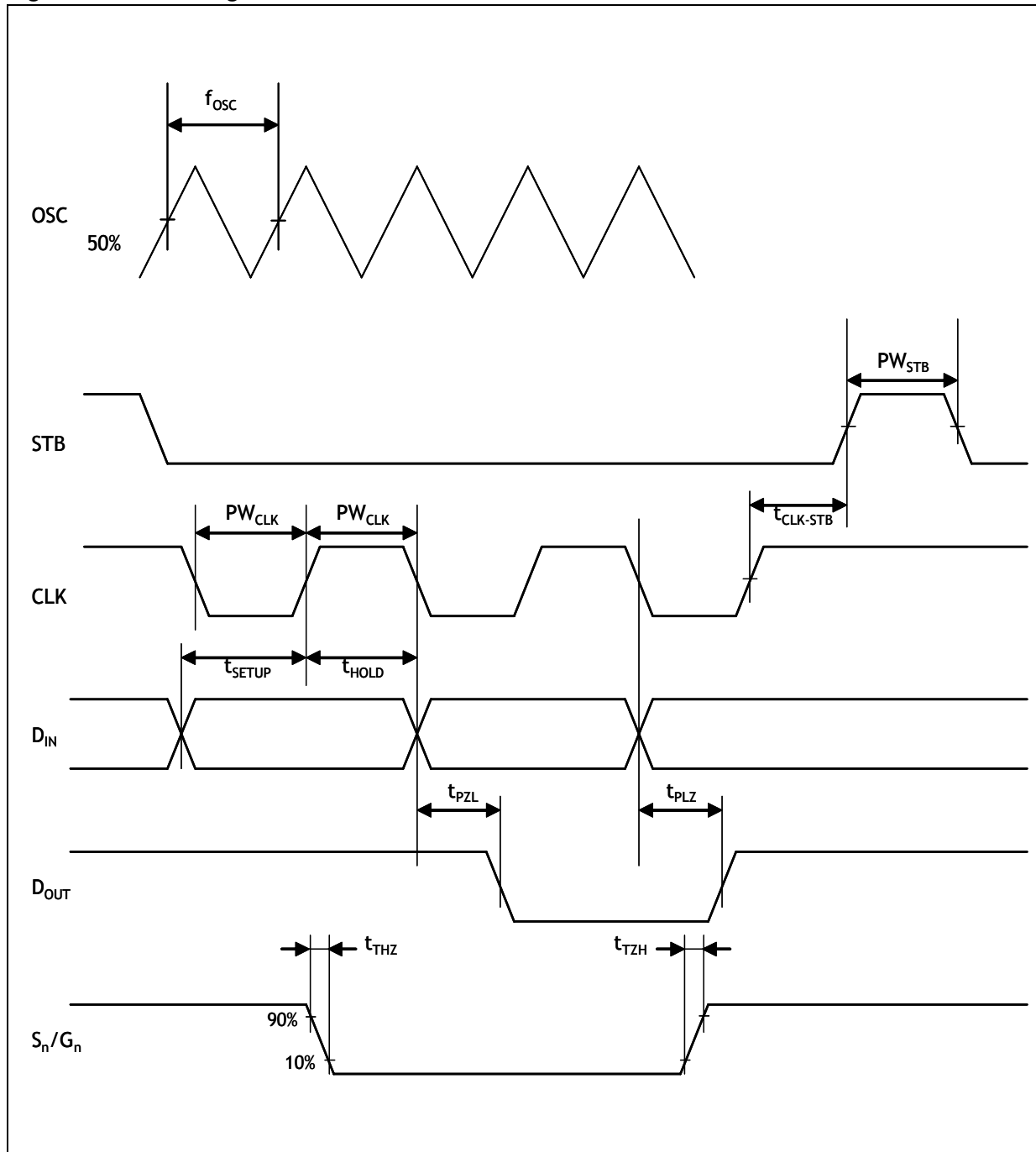
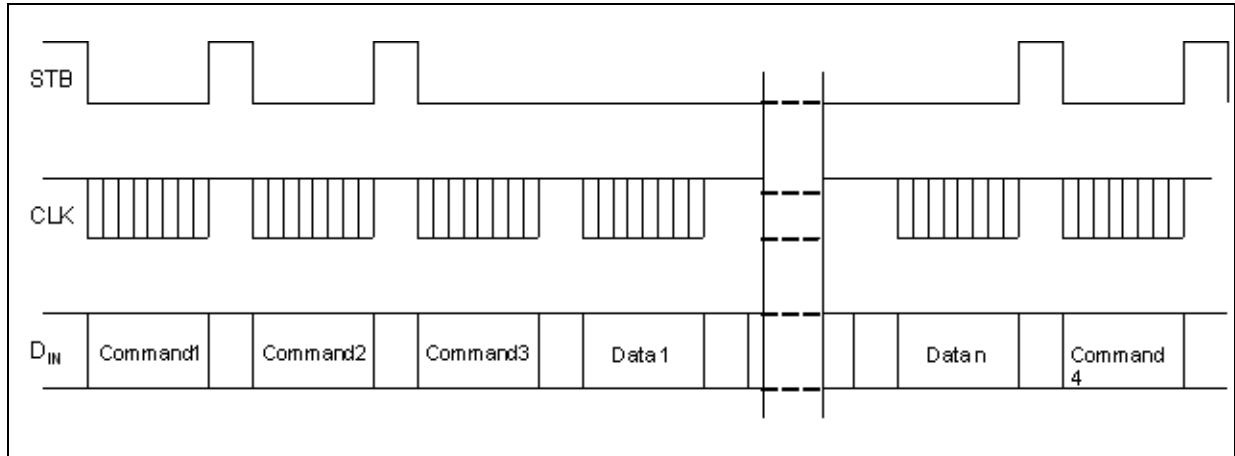

Figure 32. Switching characteristic waveforms



- Command 1: sets display mode
- Command 2: sets data
- Command 3: sets address
- Data 1 to n: transfers display data (22 bytes max.)
- Command 4: controls display

Figure 33. Updating display memory by incrementing address



- Command 1: sets data
- Command 2: sets address
- Data: display area

Figure 34. Updating specific address

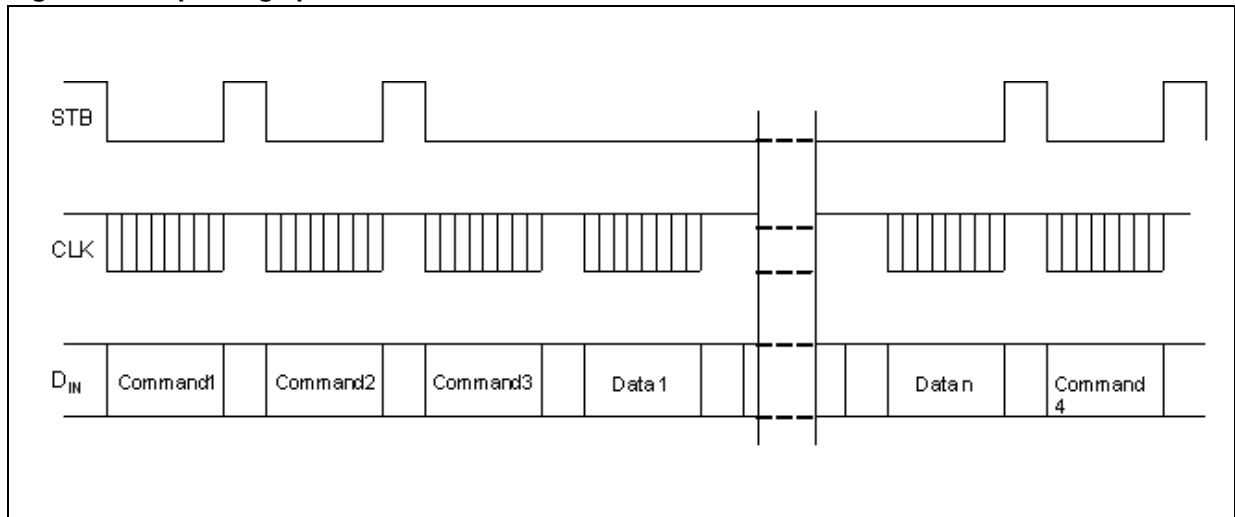

14 Typical application diagram

Figure 35. Typical application circuit

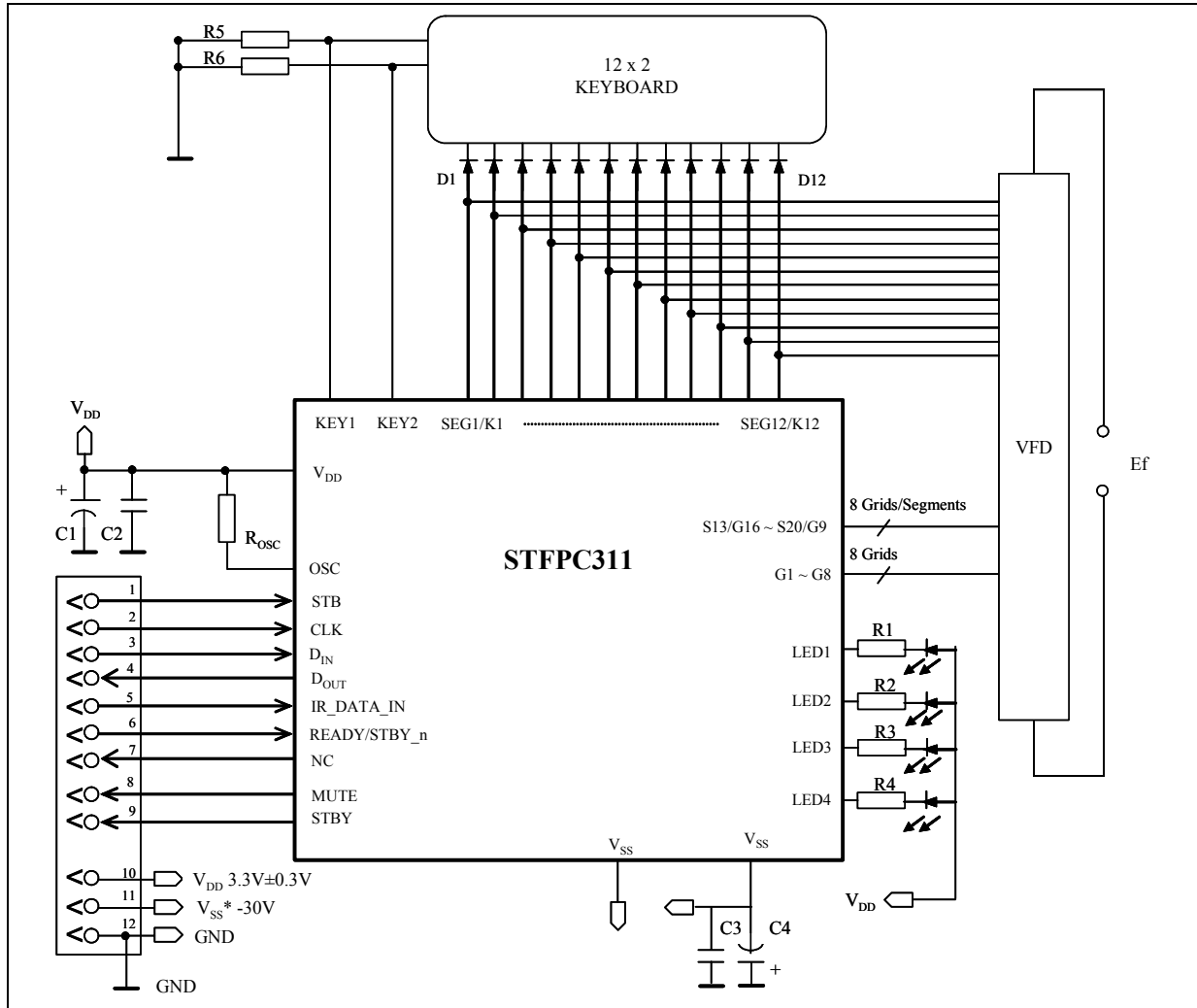

- $R_{OSC} = 33\text{ k}\Omega \pm 1\%$ for oscillator resistor;
- $R1 \sim R4 = 0.75 \sim 1.2\text{ k}\Omega$;
- $R5, R6 = 10\text{ k}\Omega$ for external keyboard pull-down resistor;
- $C1 = 33\text{ }\mu\text{F} - 25\text{ V}$ electrolytic;
- $C2 = 0.01 \sim 0.1\text{ }\mu\text{F} - 25\text{ V}$ ceramic;
- $C3 = 0.01 \sim 0.1\text{ }\mu\text{F} - 63\text{ V}$ ceramic;
- $C4 = 33\text{ }\mu\text{F} - 63\text{ V}$ electrolytic;
- $D1 \sim D12 = 1\text{N}4148$;
- E_f = filament voltage according with the VFD specs;
- $V_{DD} = 3.3\text{V} \pm 10\%$;

* $V_{SS} = \text{down to } V_{DD} - 33.3\text{ V}$

15 Package mechanical data

In order to meet environmental requirements, ST offers these devices in different grades of ECOPACK[®] packages, depending on their level of environmental compliance. ECOPACK[®] specifications, grade definitions and product status are available at: www.st.com. ECOPACK[®] is an ST trademark.

Table 10. PQFP52 - 10x10x2 mm. plastic quad flatpack, package mechanical data

Symbol	millimeters			inches		
	Typ	Min	Max	Typ	Min	Max
A			2.350			0
A1			0.250			0
A2	2.000	1.950	2.100	0	0	0
a	3.5°	0.0°	7.0°	3.5°	0.0°	7.0°
b		0.220	0.380		0	0
c		0.110	0.230		0	0
D	13.900	13.650	14.150	1	1	1
D1	10.000	9.800	10.200	0	0	0
D2	7.800	-	-	0	-	-
ddd			0.100			0
E	13.900	13.650	14.150	1	1	1
e	0.650	-	-	0	-	-
E1	10.000	9.800	10.200	0	0	0
E2	7.800	-	-	0	-	-
L	0.880	0.730	1.030	0	0	0
L1	1.950	-	-	0	-	-
N	52			52		
Ne	13			13		
Nd	13			13		

Figure 36. Package dimensions

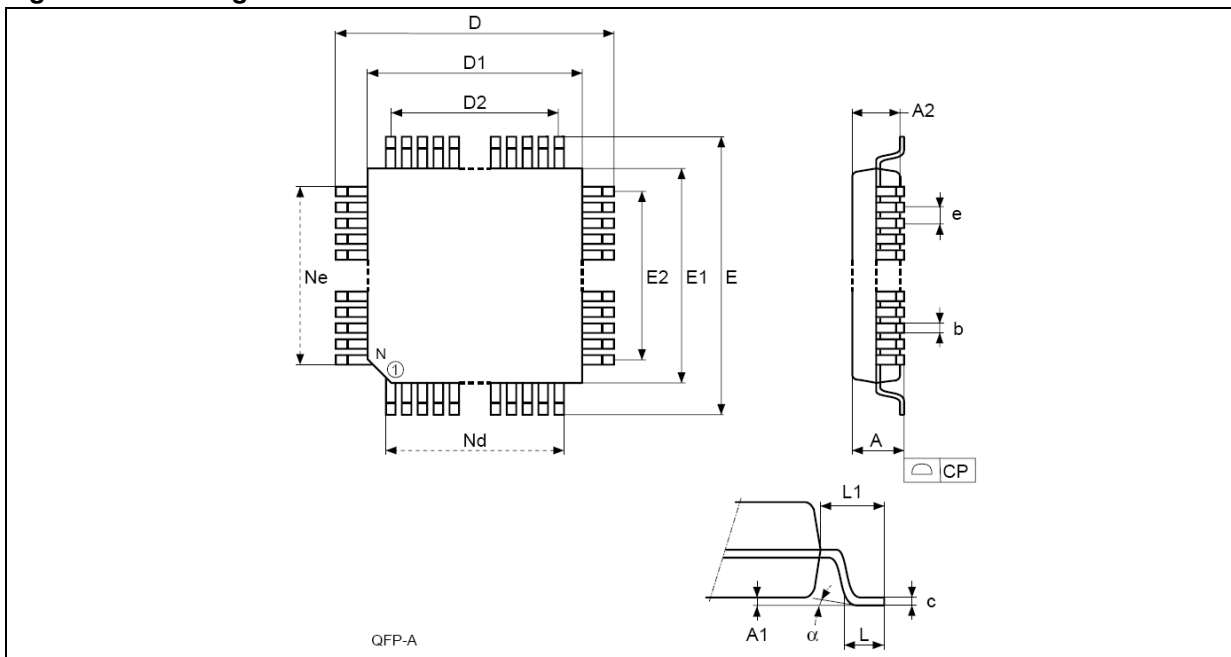

16 Revision history

Table 11. Revision history

Date	Revision	Changes
09-May-2006	1	First release
10-Sep-2012	2	Document/product status updated to "not recommended for new design" Minor textual modifications Updated ECOPACK® text in Section 15: Package mechanical data

Please Read Carefully:

Information in this document is provided solely in connection with ST products. STMicroelectronics NV and its subsidiaries ("ST") reserve the right to make changes, corrections, modifications or improvements, to this document, and the products and services described herein at any time, without notice.

All ST products are sold pursuant to ST's terms and conditions of sale.

Purchasers are solely responsible for the choice, selection and use of the ST products and services described herein, and ST assumes no liability whatsoever relating to the choice, selection or use of the ST products and services described herein.

No license, express or implied, by estoppel or otherwise, to any intellectual property rights is granted under this document. If any part of this document refers to any third party products or services it shall not be deemed a license grant by ST for the use of such third party products or services, or any intellectual property contained therein or considered as a warranty covering the use in any manner whatsoever of such third party products or services or any intellectual property contained therein.

UNLESS OTHERWISE SET FORTH IN ST'S TERMS AND CONDITIONS OF SALE ST DISCLAIMS ANY EXPRESS OR IMPLIED WARRANTY WITH RESPECT TO THE USE AND/OR SALE OF ST PRODUCTS INCLUDING WITHOUT LIMITATION IMPLIED WARRANTIES OF MERCHANTABILITY, FITNESS FOR A PARTICULAR PURPOSE (AND THEIR EQUIVALENTS UNDER THE LAWS OF ANY JURISDICTION), OR INFRINGEMENT OF ANY PATENT, COPYRIGHT OR OTHER INTELLECTUAL PROPERTY RIGHT.

UNLESS EXPRESSLY APPROVED IN WRITING BY TWO AUTHORIZED ST REPRESENTATIVES, ST PRODUCTS ARE NOT RECOMMENDED, AUTHORIZED OR WARRANTED FOR USE IN MILITARY, AIR CRAFT, SPACE, LIFE SAVING, OR LIFE SUSTAINING APPLICATIONS, NOR IN PRODUCTS OR SYSTEMS WHERE FAILURE OR MALFUNCTION MAY RESULT IN PERSONAL INJURY, DEATH, OR SEVERE PROPERTY OR ENVIRONMENTAL DAMAGE. ST PRODUCTS WHICH ARE NOT SPECIFIED AS "AUTOMOTIVE GRADE" MAY ONLY BE USED IN AUTOMOTIVE APPLICATIONS AT USER'S OWN RISK.

Resale of ST products with provisions different from the statements and/or technical features set forth in this document shall immediately void any warranty granted by ST for the ST product or service described herein and shall not create or extend in any manner whatsoever, any liability of ST.

ST and the ST logo are trademarks or registered trademarks of ST in various countries.

Information in this document supersedes and replaces all information previously supplied.

The ST logo is a registered trademark of STMicroelectronics. All other names are the property of their respective owners.

© 2012 STMicroelectronics - All rights reserved

STMicroelectronics group of companies

Australia - Belgium - Brazil - Canada - China - Czech Republic - Finland - France - Germany - Hong Kong - India - Israel - Italy - Japan - Malaysia - Malta - Morocco - Philippines - Singapore - Spain - Sweden - Switzerland - United Kingdom - United States of America

www.st.com

