



STG3155

Low voltage 0.5Ω Max single SPDT switch with break-before-make feature

Features

- High speed:
 - $t_{PD} = 1.5\text{ns}$ (Typ.) at $V_{CC} = 3.0\text{V}$
 - $t_{PD} = 1.5\text{ns}$ (Typ.) at $V_{CC} = 2.3\text{V}$
- Ultra low power dissipation:
 - $I_{CC} = 0.2\mu\text{A}$ (Max.) at $T_A = 85^\circ\text{C}$
- Low "ON" resistance:
 - $R_{ON} = 0.5\Omega$ ($T_A = 25^\circ\text{C}$) at $V_{CC} = 4.3\text{V}$
 - $R_{ON} = 0.6\Omega$ ($T_A = 25^\circ\text{C}$) at $V_{CC} = 3.0\text{V}$
 - $R_{ON} = 1.0\Omega$ ($T_A = 25^\circ\text{C}$) at $V_{CC} = 1.8\text{V}$
- Wide operating voltage range:
 - V_{CC} (OPR) = 1.65V to 4.3V single supply
- 4.3V Tolerant and 1.8V compatible threshold on digital control input at $V_{CC} = 2.3\text{V}$ to 3.0V
- Latch-up performance exceeds 300mA (JESD 17)
- ESD Performance (Analog Chan. Vs. GND):
HMB >2kV (MIL STD 883 method 3015)

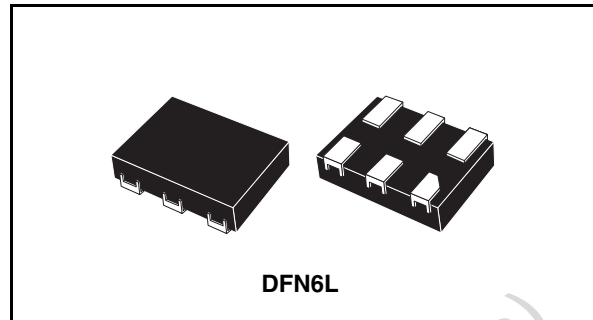

Description

The STG3155 is a high-speed CMOS low voltage single analog S.P.D.T. (Single Pole Dual Throw) switch or 2:1 Multiplexer/Demultiplexer switch fabricated in silicon gate C²MOS technology. It is designed to operate from 1.65V to 4.3V, making this device ideal for portable applications.

The device offers very low ON-Resistance (<0.5Ω) at $V_{CC} = 4.3\text{V}$. The SEL inputs are provided to control the switch. The switch S1 is ON (they are connected to common Ports Dn) when the SEL input is held high and OFF (high impedance state exists between the two ports) when SEL is held low; the switch S2 is ON (it is connected to common Port D) when the SEL input is held low and OFF (high impedance state exists between the two ports) when SEL is held high.

Additional key features are fast switching speed, break-before-make delay time and Ultra Low Power Consumption. All inputs and outputs are equipped with protection circuits against static discharge, giving them ESD immunity and transient excess voltage.

Table 1. Device summary

Part number	Package	Packaging
STG3155DTR	DFN6L (1.45mm x 1mm)	Tape and Reel

Contents

1	Pin connections and functions	3
2	Electrical ratings	4
3	Electrical characteristics	5
3.1	DC Electrical characteristics	5
3.2	AC Electrical characteristics	7
3.3	Analog switch characteristics	8
3.4	Truth table	8
4	Typical application circuit	9
5	Test circuit	10
6	Package mechanical data	12
7	Revision history	14

Obsolete Product(s) - Obsolete Product(s)

1 Pin connections and functions

Figure 1. Pin connections (top through view)

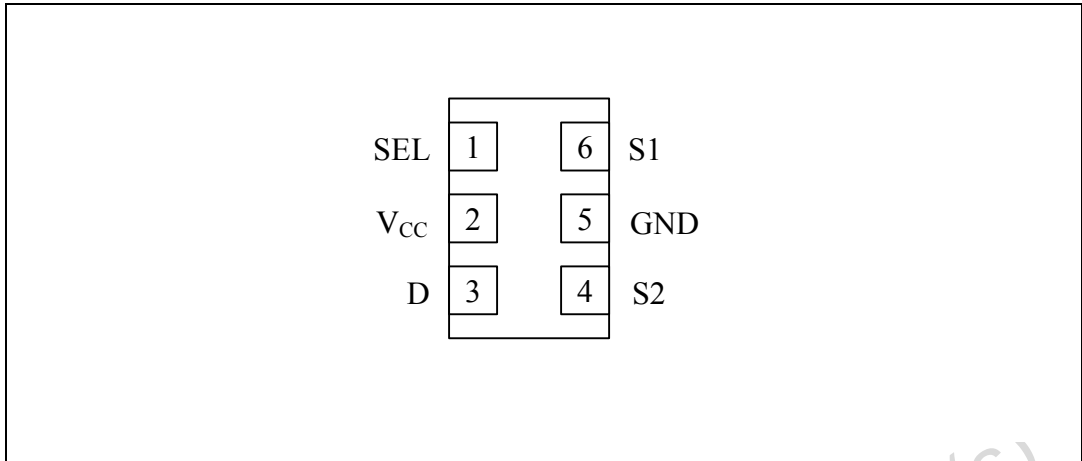
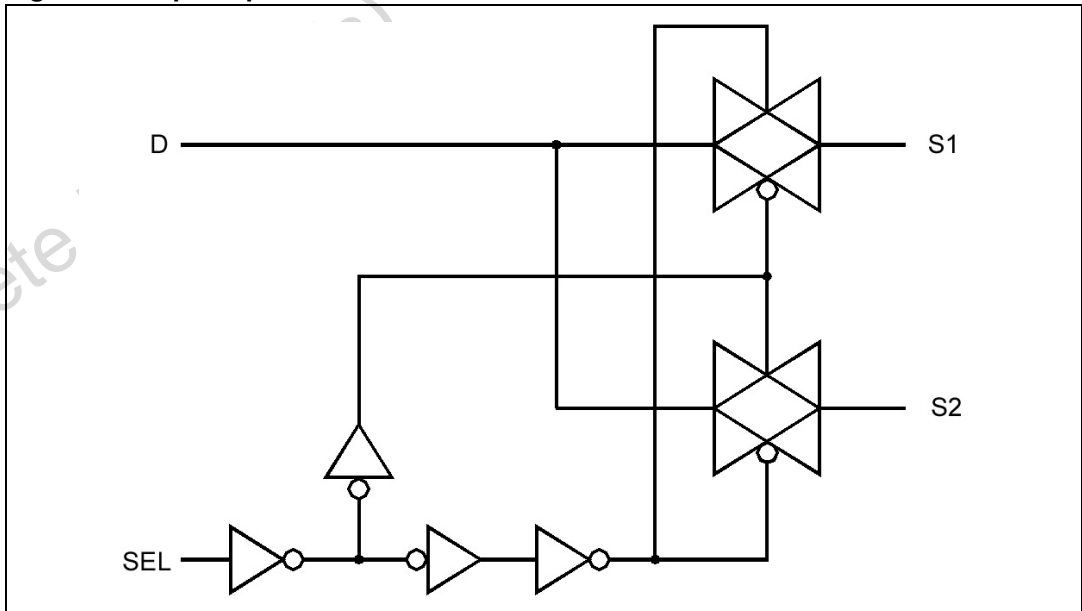

Table 2. Pin descriptions

Pin N°	Symbol	Name and function
6, 4	S1, S2	Independent Channels
3	D	Common Channels
1	SEL	Control
2	V _{CC}	Positive Supply Voltage
5	GND	Ground (0V)

Figure 2. Input equivalent circuit



2 Electrical ratings

Stressing the device above the rating listed in the “Absolute Maximum Ratings” table may cause permanent damage to the device. These are stress ratings only and operation of the device at these or any other conditions above those indicated in the Operating sections of this specification is not implied. Exposure to Absolute Maximum Rating conditions for extended periods may affect device reliability. Refer also to the STMicroelectronics SURE Program and other relevant quality documents.

Table 3. Absolute maximum ratings

Symbol	Parameter	Value	Unit
V_{CC}	Supply voltage	-0.5 to 5.5	V
V_I	DC Input voltage	-0.5 to $V_{CC} + 0.5$	V
V_{IC}	DC Control input voltage	-0.5 to 5.5	V
V_O	DC Output voltage	-0.5 to $V_{CC} + 0.5$	V
I_{IKC}	DC Input diode current on control pin ($V_{SEL} < 0V$)	-50	mA
I_{IK}	DC Input diode current ($V_{SEL} < 0V$)	± 50	mA
I_{OK}	DC Output diode current	± 20	mA
I_O	DC Output current	± 200	mA
I_{OP}	DC Output current peak (pulse at 1ms, 10% duty cycle)	± 500	mA
I_{CC} or I_{GND}	DC V_{CC} or ground current	± 100	mA
P_D	Power dissipation at $T_A = 70^\circ C$ ⁽¹⁾	1120	mW
T_{stg}	Storage temperature	-65 to 150	$^\circ C$
T_L	Lead temperature (10 sec)	300	$^\circ C$

1. Derate above 70°C by 18.5mW/C

Table 4. Recommended operating conditions

Symbol	Parameter	Value	Unit	
V_{CC}	Supply voltage ⁽¹⁾	1.65 to 4.3	V	
V_I	Input voltage	0 to V_{CC}	V	
V_{IC}	Control input voltage	0 to 4.3	V	
V_O	Output voltage	0 to V_{CC}	V	
T_{op}	Operating temperature	-55 to 125	$^\circ C$	
dt/dv	Input rise and fall time control input	$V_{CC} = 1.65V$ to $2.7V$	0 to 20	ns/V
		$V_{CC} = 3.0$ to $4.3V$	0 to 10	

1. Truth table guaranteed: 1.2V to 4.3V

3 Electrical characteristics

3.1 DC Electrical characteristics

Table 5. DC Specifications

Symbol	Parameter	Test conditions		Value						Unit	
		V _{CC} (V)		T _A = 25°C			-40 to 85°C		-55 to 125°C		
				Min.	Typ.	Max.	Min.	Max.	Min.		Max.
V _{IH}	High Level Input Voltage	1.65-1.95		0.65V _{CC}			0.65V _{CC}		0.65V _{CC}		V
		2.3-2.5		1.2			1.2		1.2		
		2.7-3.0		1.3			1.3		1.3		
		3.3-3.6		1.4			1.4		1.4		
		4.3		1.6			1.6		1.6		
V _{IL}	Low Level Input Voltage	1.65-1.95				0.25		0.25		0.25	V
		2.3-2.5				0.25		0.25		0.25	
		2.7-3.0				0.25		0.25		0.25	
		3.3-3.6				0.30		0.30		0.30	
		4.3				0.40		0.40		0.40	
R _{PEAK}	Switch ON Peak Resistance	1.8	V _S = 0V to V _{CC} I _S = 100mA		1.1	1.5		1.5			Ω
		2.7			0.7	0.8		0.9			
		3.0			0.7	0.8		0.9			
		4.3			0.6	0.7		0.8			
R _{ON}	Switch On Resistance	1.8	V _S = 0.9V I _S = 100mA		1.0	1.2		1.4			Ω
		2.7	V _S = 1.3V I _S = 100mA		0.6	0.7		0.8			
		3.0	V _S = 1.5V I _S = 100mA		0.6	0.7		0.8			
		4.3	V _S = 2.5V I _S = 100mA		0.5	0.6		0.7			
ΔR _{ON}	ON Resistance Match between channels ⁽¹⁾	1.8	V _S @ R _{ON} Max I _S = 100mA		12						mΩ
		2.7			17						
		3.0			18						
		4.3			21						
R _{FLAT}	ON Resistance FLATNESS ⁽²⁾	1.8	V _S = 0V to V _{CC} I _S = 100mA		0.45	0.50		0.50			Ω
		2.7			0.28	0.32		0.32			
		3.0			0.27	0.32		0.32			
		4.3			0.25	0.30		0.30			

Table 5. DC Specifications (continued)

Symbol	Parameter	Test conditions		Value						Unit	
		Vcc (V)		T _A = 25°C			-40 to 85°C		-55 to 125°C		
				Min.	Typ.	Max.	Min.	Max.	Min.		Max.
I _{OFF}	OFF State Leakage Current (SN), (D)	4.3	V _S = 0.3 or 4V			±20		±100			nA
I _{IN}	Input Leakage Current	0 – 4.3	V _{SEL} = 0 to 4.3V			±0.1		±1			µA
I _{CC}	Quiescent Supply Current	1.65 – 4.3	V _{SEL} = V _{CC} or GND			±0.05		±0.2		±1	µA
I _{CCLV}	Quiescent Supply Current Low Voltage Driving	4.3	V _{SEL} = 1.65V		±23	±50		±100			µA
			V _{SEL} = 1.80V		±18	±40		±50			
			V _{SEL} = 2.60V		±7	±20		±30			

1. $\Delta R_{ON} = R_{ON(Max)} - R_{ON(Min)}$
2. Flatness is defined as the difference between the maximum and minimum value of ON-resistance as measured over the specified analog signal ranges.

Obsolete Product(s) - Obsolete Product(s)

3.2 AC Electrical characteristics

$$C_L = 35\text{pF}, R_L = 50\Omega, t_r = t_f \leq 5\text{ns}$$

Table 6. AC Electrical characteristics

Symbol	Parameter	Test conditions		Value						Unit	
		Vcc (V)		T _A = 25°C			-40 to 85°C		-55 to 125°C		
				Min.	Typ.	Max.	Min.	Max.	Min.		Max.
t _{PLH} , t _{PHL}	Propagation Delay	1.65-1.95	V _S = OPEN		0.45						ns
		2.3-2.7			0.40						
		3.0-3.3			0.30						
		3.6-4.3			0.30						
t _{ON}	TURN-ON time	1.65-1.95	V _S = 0.8V		120						ns
		2.3-2.7	V _S = 1.5V		45	55		65			
		3.0-3.3			52	55		65			
		3.6-4.3			40	55		65			
t _{OFF}	TURN-OFF time	1.65-1.95	V _S = 0.8		22						ns
		2.3-2.7	V _S = 1.5V		18	30		40			
		3.0-3.3			16	30		40			
		3.6-4.3			15	30		40			
t _D	Break Before Make Time Delay	1.65-1.95	C _L = 35pF R _L = 50Ω V _S = 1.5V		28						ns
		2.3-2.7			10						
		3.0-3.3			7						
		3.6-4.3			4						
Q	Charge Injection	1.65	C _L = 100pF V _{GEN} = 0V R _{GEN} = 0Ω		25						pC
		2.3			34						
		3			42						
		4.3			53						

3.3 Analog switch characteristics

$C_L = 5\text{pF}$, $R_L = 50\Omega$, $T_A = 25^\circ\text{C}$

Table 7. Analog switch characteristics

Symbol	Parameter	Test conditions		Value						Unit		
		Vcc (V)		T _A = 25°C			-40 to 85°C		-55 to 125°C			
				Min.	Typ.	Max.	Min.	Max.	Min.		Max.	
OIRR	Off Isolation (1)	1.65-4.3	V _S = 1V _{RMS} f = 100kHz		-74							dB
Xtalk	Crosstalk	1.6-4.3	V _S = 1V _{RMS} f = 100kHz		-72							dB
THD	Total Harmonic Distortion	2.3-4.3	R _L = 600Ω V _S = 2V _{PP} f = 20Hz to 20 kHz		0.03							%
BW	-3dB Bandwidth	1.65-4.3	R _L = 50Ω		70							MHz
C _{IN}	Control Pin Input Capacitance				6.6							pF
C _{Sn}	Sn Port Capacitance	3.3	f = 1MHz		42							
C _D	D Port Capacitance when Switch is Enabled	3.3	f = 1MHz		103							

1. OFF Isolation = $20\text{Log}_{10}(V_D/V_S)$, V_D = output. V_S = input to OFF switch.

3.4 Truth table

Table 8. Truth table

Sel	Switch S1	Switch S2
H	ON	OFF (1)
L	OFF (1)	ON

1. High impedance

4 Typical application circuit

Figure 3. ON-Resistance

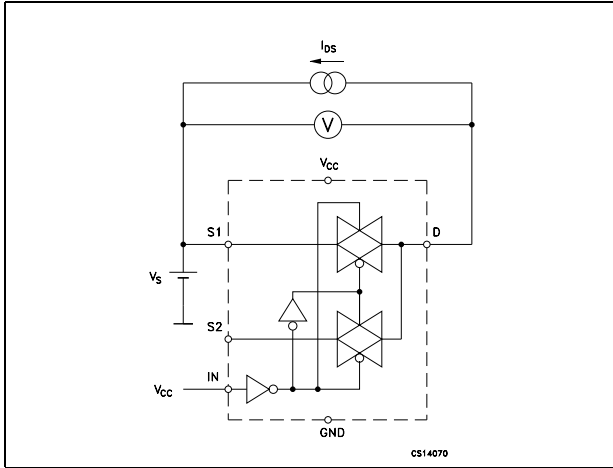

Figure 4. Bandwidth

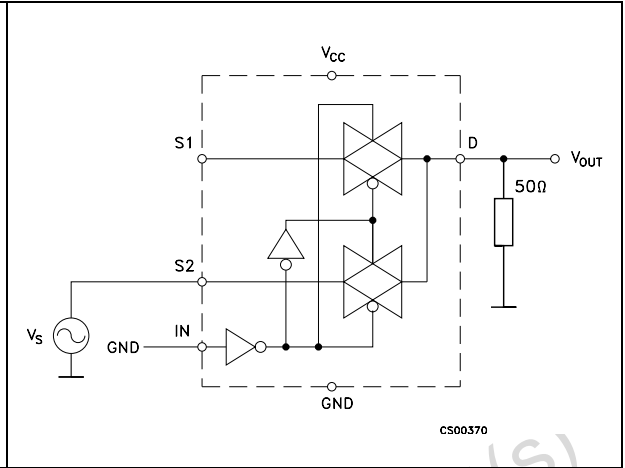

Figure 5. OFF Leakage

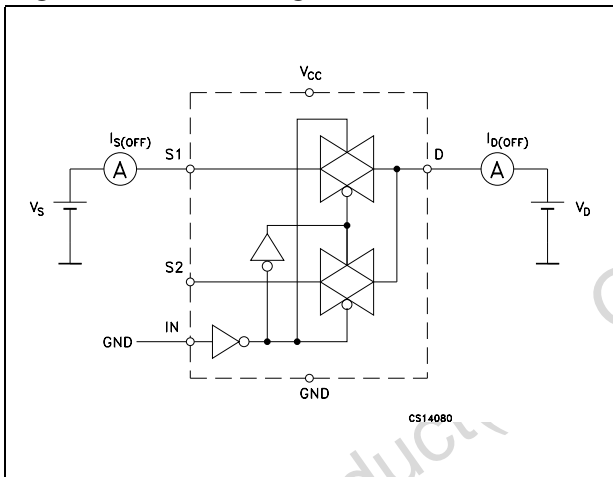

Figure 6. Channel to channel crosstalk

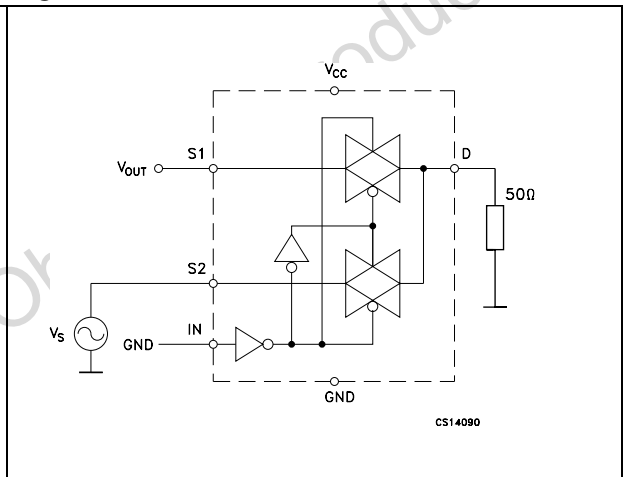
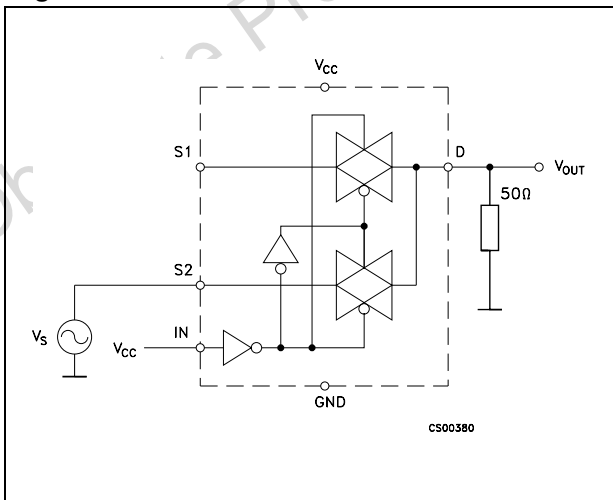
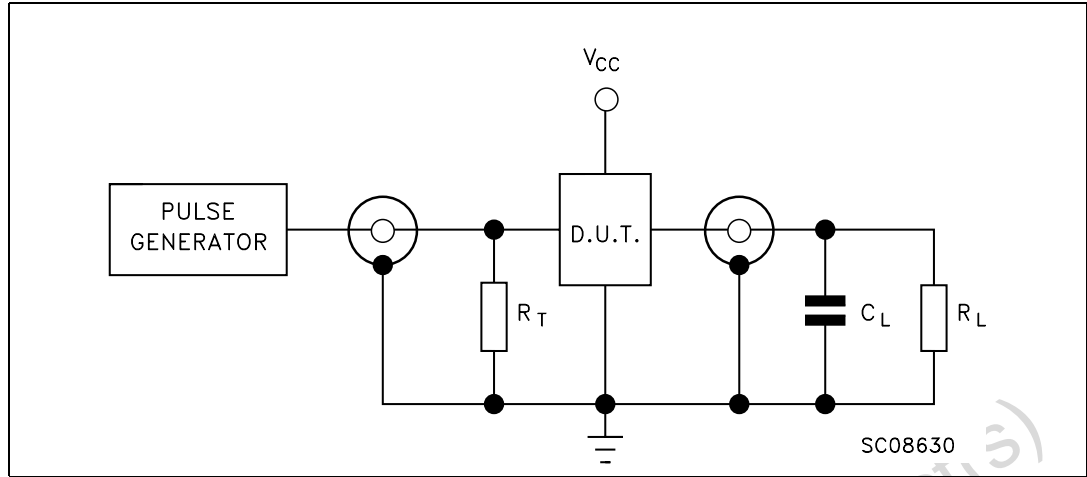

Figure 7. OFF Isolation



5 Test circuit

Figure 8. Test circuit



Note: $C_L = 5/35\text{pF}$ or equivalent: (includes jig capacitance)
 $R_L = 50\Omega$ or equivalent
 $R_T = Z_{OUT}$ of pulse generator (typically 50Ω)

Figure 9. Break-before-make time delay

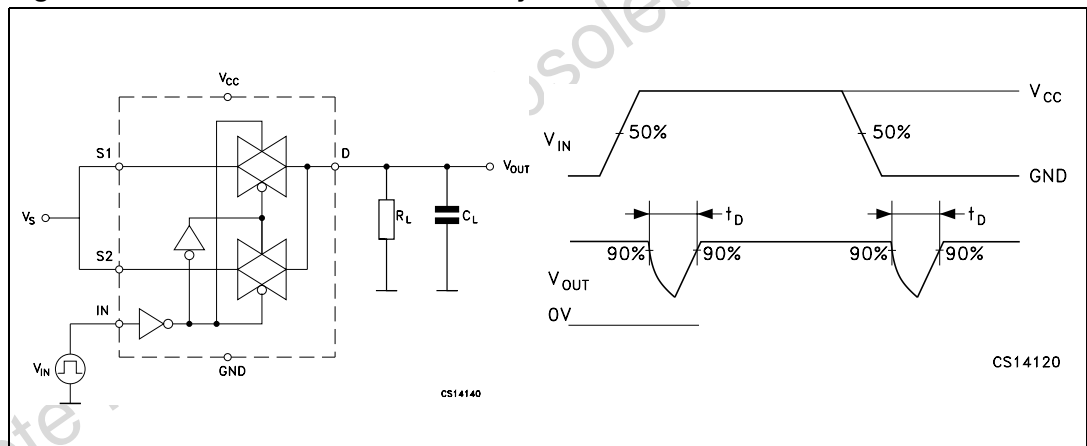

Figure 10. Switching time and charge injection
 ($V_{GEN} = 0V$, $R_{GEN} = 0\Omega$, $R_L = 1M\Omega$, $C_L = 100pF$)

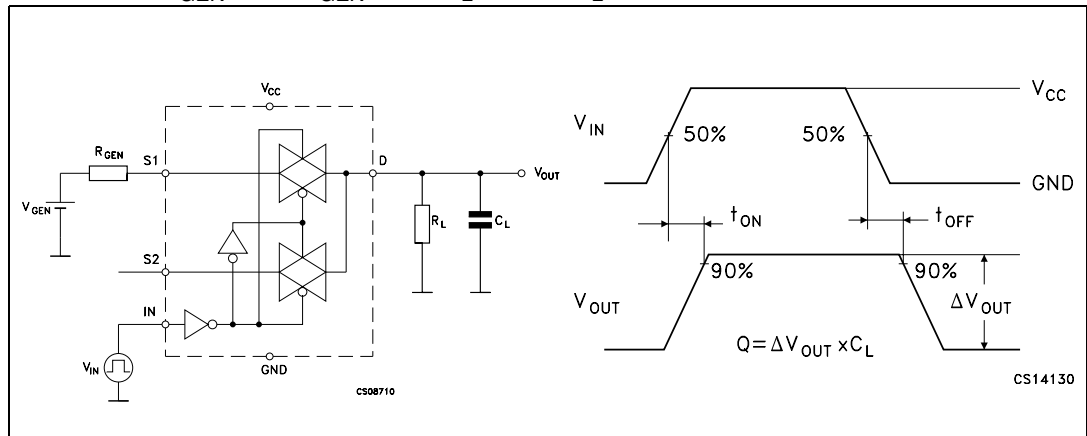
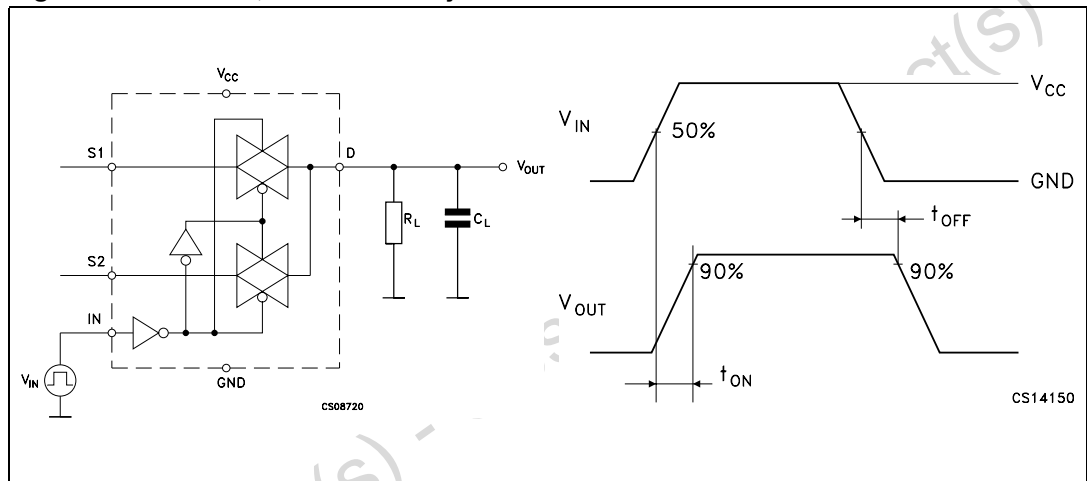

Figure 11. Turn ON, turn OFF delay time



Obsolete Product(s) - t(s)

6 Package mechanical data

In order to meet environmental requirements, ST offers these devices in ECOPACK® packages. These packages have a Lead-free second level interconnect. The category of second level interconnect is marked on the package and on the inner box label, in compliance with JEDEC Standard JESD97. The maximum ratings related to soldering conditions are also marked on the inner box label. ECOPACK is an ST trademark. ECOPACK specifications are available at: www.st.com

Obsolete Product(s) - Obsolete Product(s)

Table 9. DFN6L (1.45mm x 1mm) Mechanical data

Dim.	mm.			inch		
	Min.	Typ.	Max.	Min.	Typ.	Max.
A	0.45	0.50	0.55	0.017	0.019	0.021
A1	0	0.02	0.05	0	0.001	0.002
A3		0.127			0.005	
b	0.20	0.25	0.30	0.007	0.010	0.011
D	1.35	1.45	1.55	0.053	0.057	0.061
E	0.90	1	1.10	0.035	0.040	0.043
e		0.50			0.020	
L	0.25	0.35	0.45	0.010	0.013	0.017

Figure 12. Package dimensions

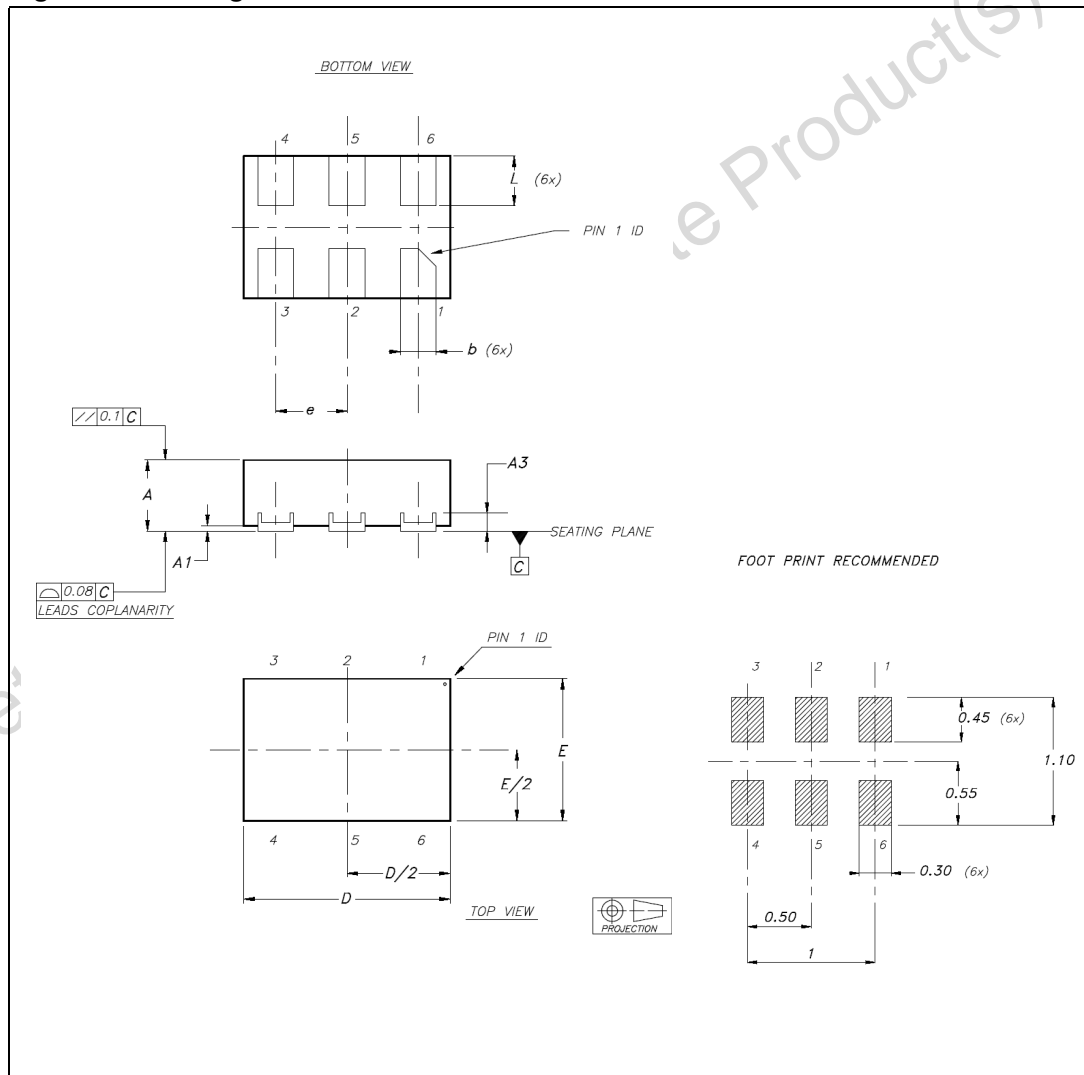
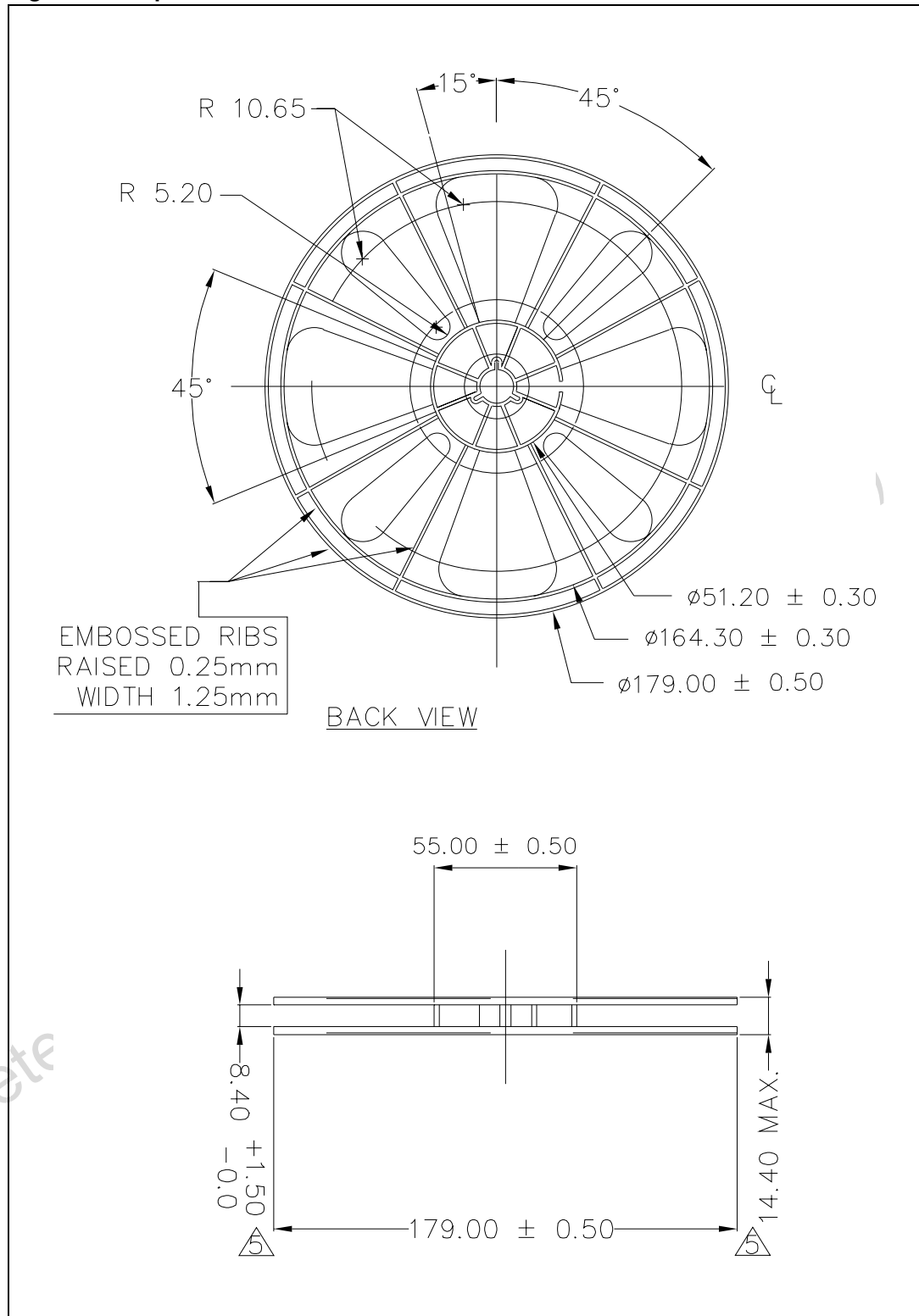
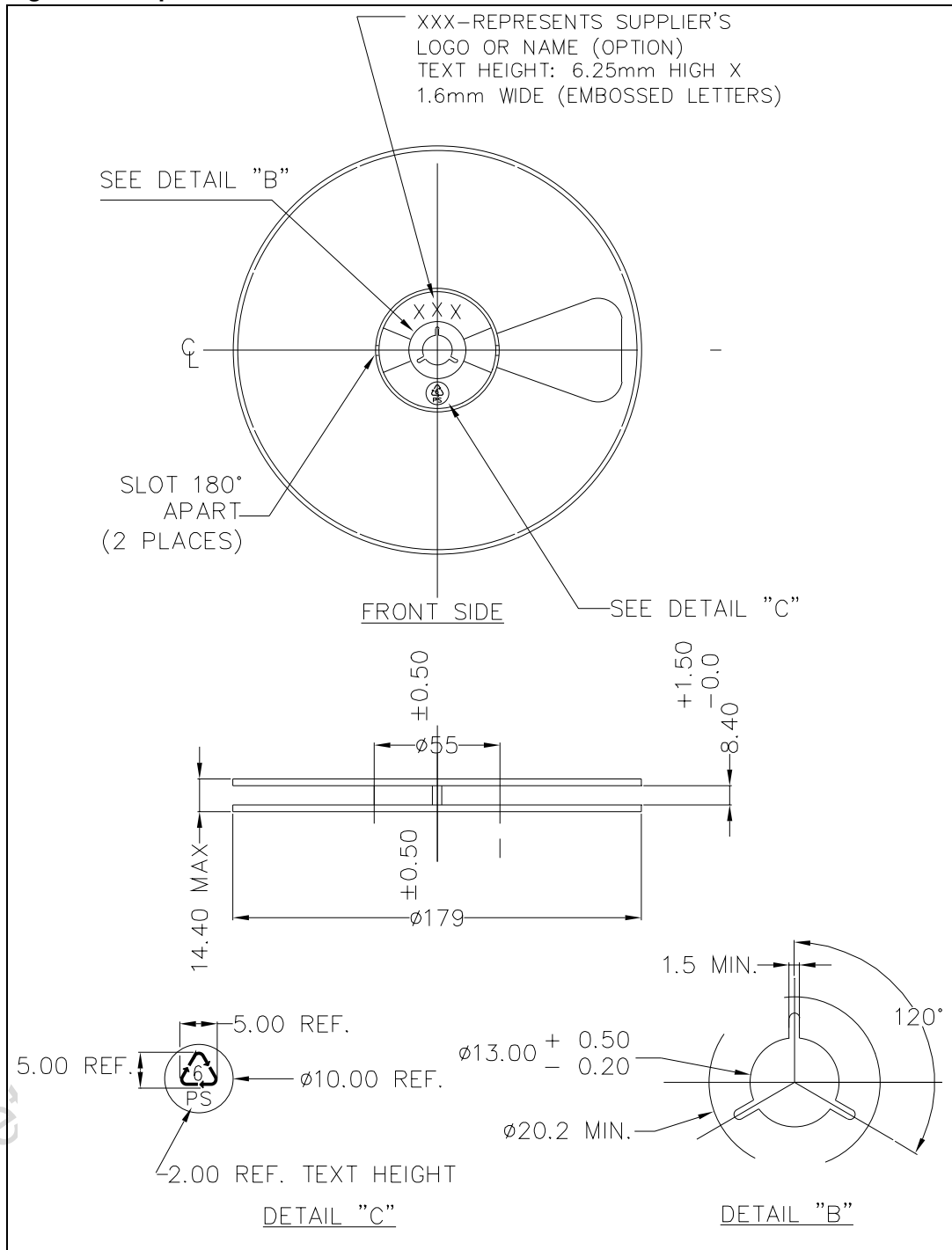

Figure 13. Tape and Reel Information



Obsolete

Figure 14. Tape and Reel Information



Obsolete

Figure 15. Tape and Reel Information

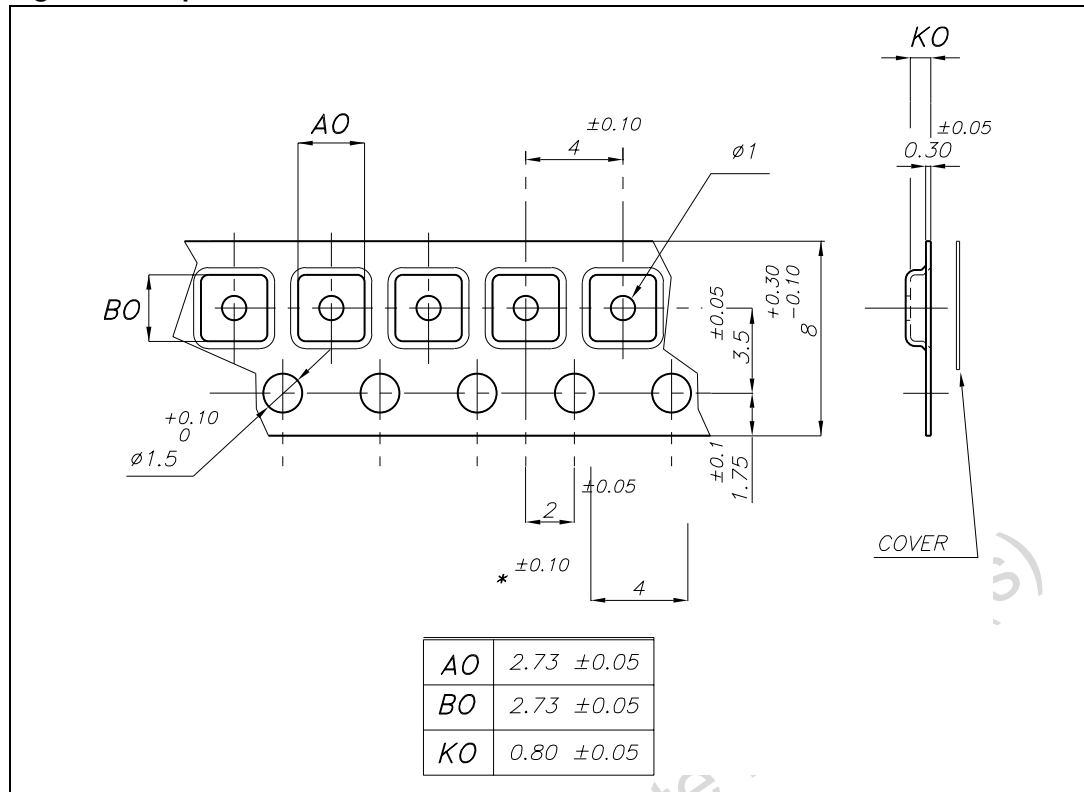

Obsolete Product(s) - Obsolete

7 Revision history

Table 10. Document revision history

Date	Revision	Changes
22-Feb-2006	1	First release
25-May-2007	2	Updated R _{ON} values on Chapter Table 5.: DC Specifications

Obsolete Product(s) - Obsolete Product(s)

Please Read Carefully:

Information in this document is provided solely in connection with ST products. STMicroelectronics NV and its subsidiaries ("ST") reserve the right to make changes, corrections, modifications or improvements, to this document, and the products and services described herein at any time, without notice.

All ST products are sold pursuant to ST's terms and conditions of sale.

Purchasers are solely responsible for the choice, selection and use of the ST products and services described herein, and ST assumes no liability whatsoever relating to the choice, selection or use of the ST products and services described herein.

No license, express or implied, by estoppel or otherwise, to any intellectual property rights is granted under this document. If any part of this document refers to any third party products or services it shall not be deemed a license grant by ST for the use of such third party products or services, or any intellectual property contained therein or considered as a warranty covering the use in any manner whatsoever of such third party products or services or any intellectual property contained therein.

UNLESS OTHERWISE SET FORTH IN ST'S TERMS AND CONDITIONS OF SALE ST DISCLAIMS ANY EXPRESS OR IMPLIED WARRANTY WITH RESPECT TO THE USE AND/OR SALE OF ST PRODUCTS INCLUDING WITHOUT LIMITATION IMPLIED WARRANTIES OF MERCHANTABILITY, FITNESS FOR A PARTICULAR PURPOSE (AND THEIR EQUIVALENTS UNDER THE LAWS OF ANY JURISDICTION), OR INFRINGEMENT OF ANY PATENT, COPYRIGHT OR OTHER INTELLECTUAL PROPERTY RIGHT.

UNLESS EXPRESSLY APPROVED IN WRITING BY AN AUTHORIZED ST REPRESENTATIVE, ST PRODUCTS ARE NOT RECOMMENDED, AUTHORIZED OR WARRANTED FOR USE IN MILITARY, AIR CRAFT, SPACE, LIFE SAVING, OR LIFE SUSTAINING APPLICATIONS, NOR IN PRODUCTS OR SYSTEMS WHERE FAILURE OR MALFUNCTION MAY RESULT IN PERSONAL INJURY, DEATH, OR SEVERE PROPERTY OR ENVIRONMENTAL DAMAGE. ST PRODUCTS WHICH ARE NOT SPECIFIED AS "AUTOMOTIVE GRADE" MAY ONLY BE USED IN AUTOMOTIVE APPLICATIONS AT USER'S OWN RISK.

Resale of ST products with provisions different from the statements and/or technical features set forth in this document shall immediately void any warranty granted by ST for the ST product or service described herein and shall not create or extend in any manner whatsoever, any liability of ST.

ST and the ST logo are trademarks or registered trademarks of ST in various countries.

Information in this document supersedes and replaces all information previously supplied.

The ST logo is a registered trademark of STMicroelectronics. All other names are the property of their respective owners.

© 2007 STMicroelectronics - All rights reserved

STMicroelectronics group of companies

Australia - Belgium - Brazil - Canada - China - Czech Republic - Finland - France - Germany - Hong Kong - India - Israel - Italy - Japan - Malaysia - Malta - Morocco - Singapore - Spain - Sweden - Switzerland - United Kingdom - United States of America

www.st.com