



Low ON Resistance Triple, SP3T, Wide-Bandwidth Video Switch

Features

- Bi-directional operation
- 3x3 input/3output channels analog video switch
- Wide bandwidth 300MHz
- Low 4Ω switch resistance between two ports
- Excellent R_{ON} matching between channels
- Minimal propagation delay through the switch
- Low quiescent current consumption
- V_{CC} Operating Range: 4.0V to 5.5V
- Zero bounce in flow-through mode
- Control inputs compatible with TTL level
- Data and control inputs provide the undershoot clamp diode
- High ESD rating: > 2kV HBM
- -40°C to 85°C operating temperature range
- Suitable for both RGB and Component-Video Switching
- Available in a small TSSOP16 package

Applications

- Advanced TVs
- Front projectors
- LCD Monitors
- Notebook PCs
- DVD Players

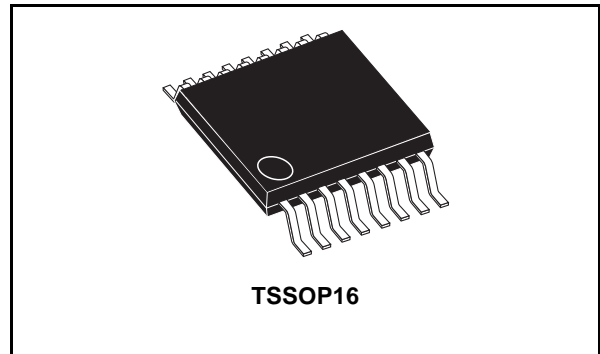

Description

The STMAV335 is a bi-directional triple (3 channel) Single Pole/Triple Throw (SP3T) high-speed, low-power CMOS TTL-compatible analog video switch designed for advanced video applications which demand superior image quality. The low ON Resistance (R_{ON}) of the switch allows inputs to be connected to outputs without adding propagation delay or generating additional ground bounce noise.

STMAV335 is designed for very low cross-talk, low bit-to-bit skew, high channel-to-channel noise isolation and low I/O capacitance. The switch offers very little or practically no attenuation of the high-speed signals at the outputs, thus preserving the signal integrity to pass stringent requirements.

Moreover the device reduces the overall BOM costs by eliminating the need for more costly multi input-output controllers.

Order Codes

Part Number	Temperature Range	Package	Comments
STMAV335	-40°C to +85°C	TSSOP16	STMAV335TTR

Contents

1	Summary Description	3
	1.1 Functional Description	3
2	Pin Configuration	4
3	Application Diagrams	5
	3.1 Power Supply Sequencing	5
4	Maximum Ratings	6
5	Electrical Characteristics	7
6	AC Loading and Diagrams	9
7	Test Circuits	10
8	Package Mechanical Data	17
9	Revision History	20

1 Summary Description

1.1 Functional Description

The STMAV335 is a high bandwidth analog video switch. Its low ON-resistance and low I/O capacitance result in a very small propagation delay.

The combination of SEL1 and SEL2 is used to either disable or enable the desired video channel. Refer to the truth table for the selection of the appropriate channels.

Figure 1. Functional Diagram

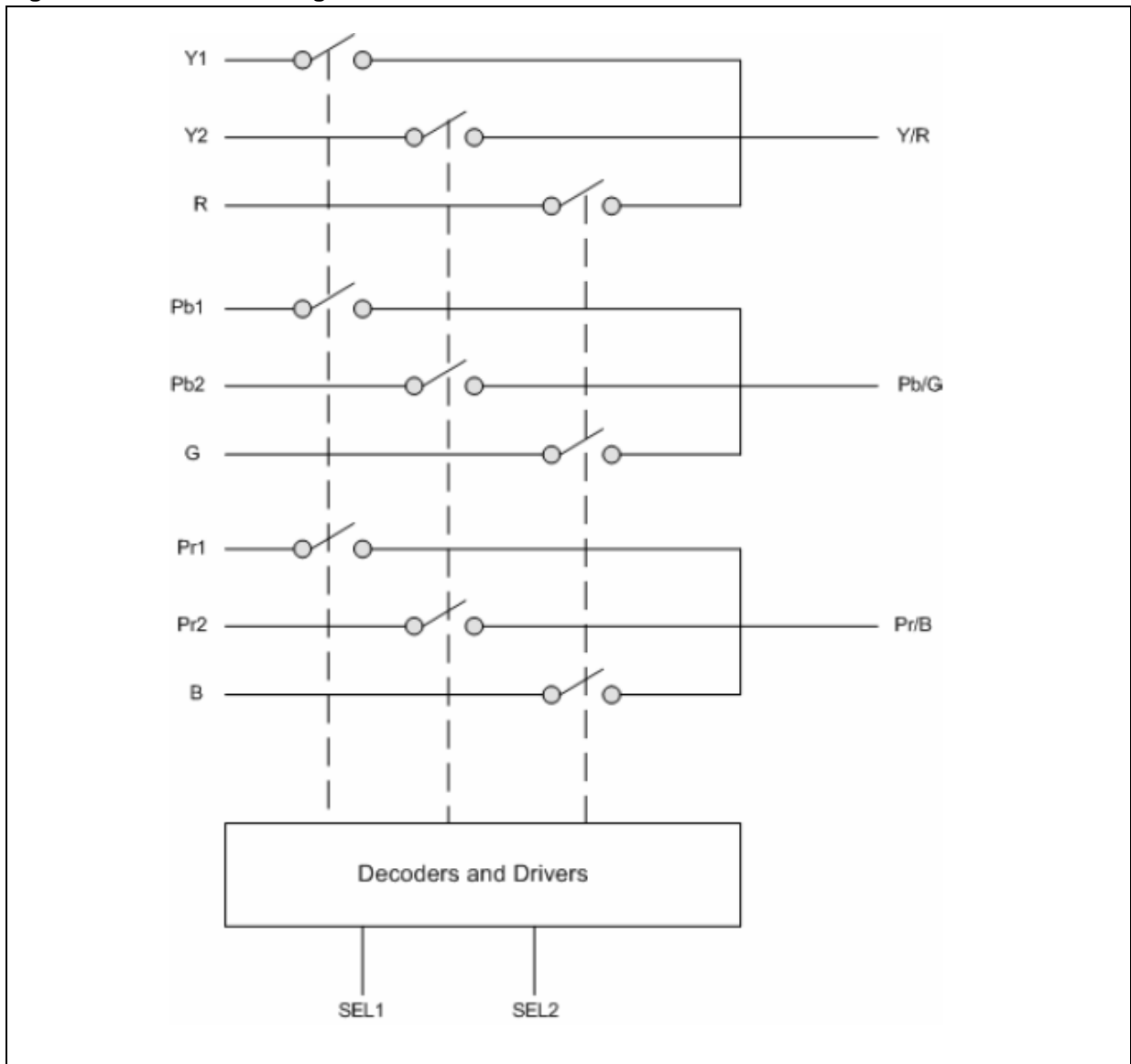

2 Pin Configuration

Figure 2. Pin Configuration (Top View)

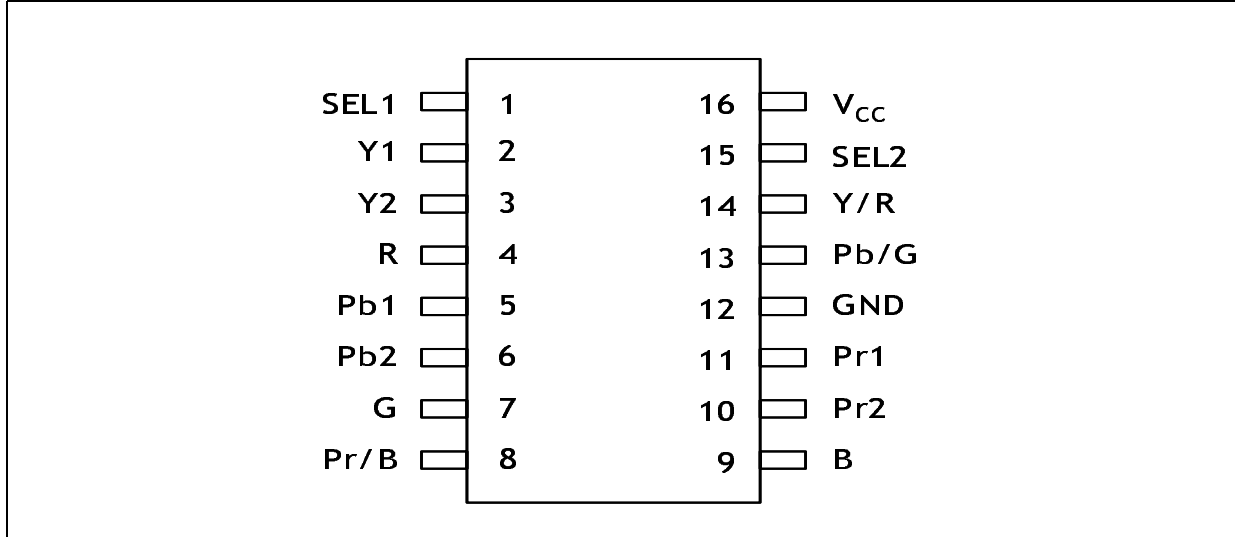

Table 1. Pin Description

Symbol	Type	Name and Functions
SEL1, SEL2	IN	Bus Switch Enable. Tie to V _{CC} through a pull-up resistor. The minimum value of the resistor is determined by the current-sinking capability of the driver.
Y/R, Pb/G, Pr/B	IN/OUT	Analog Video I/Os
Y1, Pb1, Pr1	IN/OUT	Component 1; Analog Video I/Os
Y2, Pb2, Pr2	IN/OUT	Component 2; Analog Video I/Os
R, G, B	IN/OUT	RGB or Component 3; Analog Video I/Os
V _{CC}		Power supply
GND		Ground

Table 2. Truth Table

SEL1	SEL2	Selection
0	0	Component = YPbPr1
0	1	Component = YPbPr2
1	0	Component = RGB
1	1	Switch disabled; external pull up resistor recommended

3 Application Diagrams

Figure 3. STMAV335 used in LCD TV as a 3-to-1 analog video switch

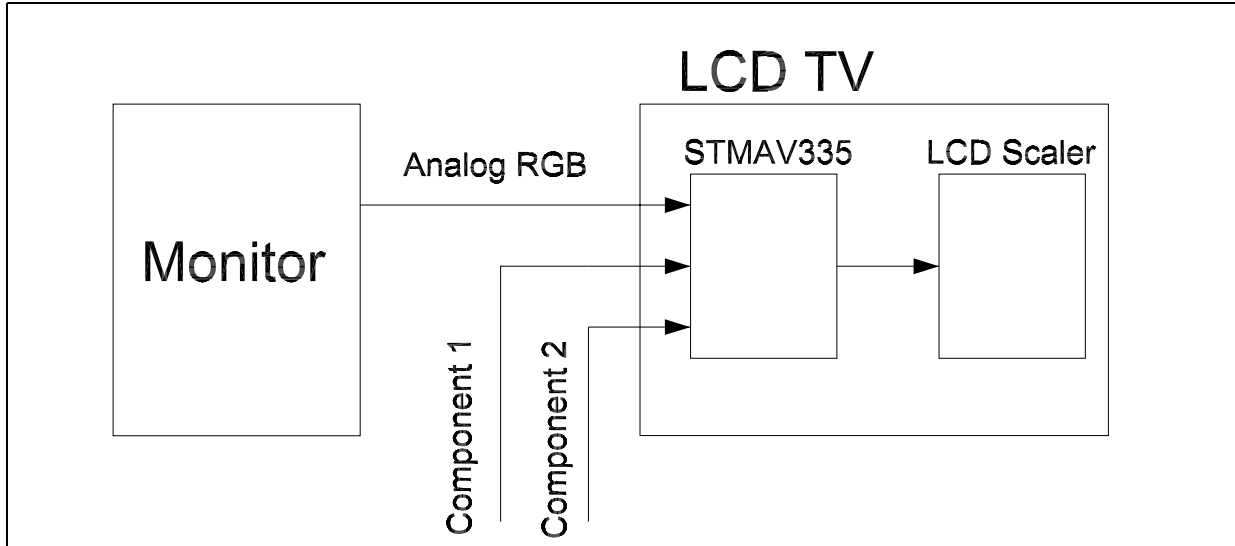
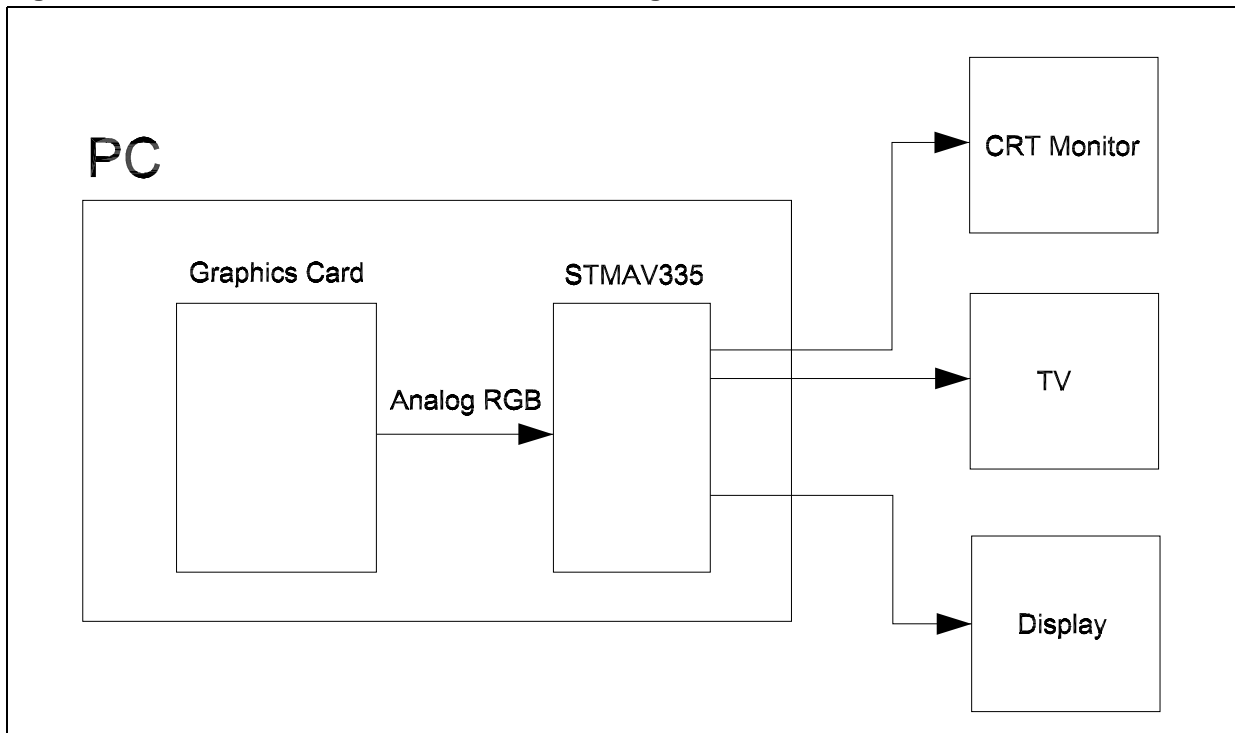

Figure 4. STMAV335 used in PC as a 1-to-3 analog video switch



3.1 Power Supply Sequencing

Proper power-supply sequencing is advised for all CMOS devices. It is recommended to always apply V_{CC} before applying any signals to the input/output or control pins.

4 Maximum Ratings

Stressing the device above the rating listed in the “Absolute Maximum Ratings” table may cause permanent damage to the device. These are stress ratings only and operation of the device at these or any other conditions above those indicated in the Operating sections of this specification is not implied. Exposure to Absolute Maximum Rating conditions for extended periods may affect device reliability. Refer also to the STMicroelectronics SURE Program and other relevant quality documents.

Table 3. Absolute Maximum Ratings

$T_A = 25^\circ\text{C}$, $V_{SS} = 0\text{V}$

Symbol	Parameter	Value	Unit
V_{CC}	Supply Voltage	-0.5 to + 7.0	V
V_S	DC Switch Voltage	-0.5 to + 7.0	V
V_{IN}	DC Input Voltage	-0.5 to + 7.0	V
I_{IK}	DC Input Diode Current	-50	mA
I_{OUT}	DC Output Sink Current	128	mA
I_{CC}/I_{GND}	DC V_{CC}/GND Current	± 100	mA
T_{STG}	Storage Temperature Range	-65 to 150	$^\circ\text{C}$

Note: Absolute maximum ratings are those values above which damage to the device may occur. Functional operation under these conditions is not implied. All voltages are referenced to GND.

5 Electrical Characteristics

Table 4. Recommended Operating Conditions

$$T_A = -20 \text{ to } +70^\circ\text{C}, V_{SS} = 0\text{V}$$

Symbol	Parameter (Note 1)	Test Conditions	Min.	Typ.	Max.	Unit
V_{CC}	Power Supply Voltage		4.0		5.5	V
V_{IN}	Input Voltage		0		5.5	V
V_{OUT}	Output Voltage		0		5.5	V
t_r, t_f	Input Rise and Fall Time	Switch Control Input	0		5	ns/V
		Switch I/O	0		DC	ns/V
T_A	Free Air Operating Temperature		-40		+85	°C
V_{ESD}	ESD-Human Body Model (HBM) Note 2		-2		+2	kV

Note: 1 Unused control inputs must be held HIGH or LOW. They should not float.

2 In accordance with IEC61000-4-2, level 4

Table 5. DC Electrical Characteristics

$$T_A = -40^\circ\text{C to } +85^\circ\text{C}$$

Symbol	Parameter	Test Conditions	$V_{CC}(V)$	Min.	Typ.	Max.	Unit
	Analog Signal Range		5	0		2.0	V
V_{IK}	Clamp Diode Voltage	$I_{IN} = -18\text{mA}$	4.5			-1.2	V
V_{IH}	HIGH Level Input Voltage		4.0-5.5	2.0			V
V_{IL}	LOW Level Input Voltage		4.0-5.5			0.8	V
I_I	Input Leakage Current	$0 \leq V_{IN} \leq 5.5\text{V}$	5.5			± 10	μA
I_{OFF}	OFF-STATE Leakage Current	$0 \leq Y/R, Pb/G, Pr/B, YX \leq V_{CC},$ $PbX \leq V_{CC}, PrX \leq V_{CC}$ $R \leq V_{CC}, G \leq V_{CC}, B \leq V_{CC}$	5.5			± 10	μA
R_{ON}	Switch ON resistance (1)	$V_{IN} = 1.0\text{V}, I_{ON} = 13\text{mA}$	4.5		3	7	Ω
		$V_{IN} = 2.0\text{V}, I_{ON} = 26\text{mA}$	4.5		7	10	Ω
I_{CC}	Quiescent Supply Current	$V_{IN} = V_{CC} \text{ or } GND, I_{OUT} = 0$	5.5			3	μA
ΔI_{CC}	Increase in I_{CC} per Input	One input at 3.4V Other inputs at V_{CC} or GND	5.5			2.5	mA

Note: 1 Measured by the voltage drop between Y/R, Pb/G, Pr/B and YX/R, PbX/G, PrX/B pins at the indicated current through the switch. ON Resistance is determined by the lower of the voltages on the two.

Table 6. AC Electrical Characteristics $T_A = -40^{\circ}\text{C}$ to $+85^{\circ}\text{C}$, $C_L = 20\text{pF}$, $R_U = R_D = 75\Omega$

Symbol	Parameter	Test conditions	$V_{CC} = 4.5 - 5.5\text{V}$			$V_{CC} = 4.0\text{V}$		Unit
			Min.	Typ.	Max.	Min.	Max.	
t_{PZH} , t_{PZL}	Output Enable Time Select to Bus YX/R, PbX/G, PrX/B	$V_I = 7\text{V}$ for t_{PZL}			5.2		5.7	ns
	Output Enable Time Select to Bus Y/R, Pb/G, Pr/B	$V_I = \text{OPEN}$ for t_{PHZ}			5.1		5.6	
t_{PHZ} , t_{PLZ}	Output Disable Time Select to Bus YX/R, PbX/G, PrX/B	$V_I = 7\text{V}$ for t_{PLZ}			5.2		5.5	ns
	Output Disable Time, Output Enable time OE_N to Bus A, B/C	$V_I = \text{OPEN}$ for t_{PHZ}			5.5		5.5	
B_W	-3dB Bandwidth	$R_L = 150\Omega$ $T_A = 25^{\circ}\text{C}$	300					MHz
X_{TALK}	Crosstalk	$R_{IN} = 10\Omega$ $R_L = 150\Omega$, 10 MHz		-58				dB
D_G	Differential Gain	$R_L = 150\Omega$ $f = 3.58\text{ MHz}$		0.64				%
D_P	Differential Phase	$R_L = 150\Omega$ $f = 3.58\text{ MHz}$		0.1				Deg.
P_{IRR}	OFF Isolation	$R_L = 150\Omega$ 10 MHz		-60				dB

Table 7. Capacitance $T_A = 25^{\circ}\text{C}$, $f = 1\text{MHz}$

Symbol	Parameter	Test Conditions	Min.	Typ.	Max.	Unit
C_{IN}	Control Pin Input Capacitance	$V_{CC} = 5.0\text{V}$		3		pF
$C_{\text{I/O}}$	Input/Output Capacitance Port: Y/R, Pb/G, Pr/B	V_{CC} , SEL1,		7		pF
	Input/Output Capacitance Port: YX/R, PbX/G, PrX/B	SEL2 = 5.0 V		5		pF
C_{ON}	Switch On Capacitance	$V_{CC} = 5.0\text{V}$, Except SEL1, SEL2=5.0		12		pF

6 AC Loading and Diagrams

Figure 5. AC Test Circuit

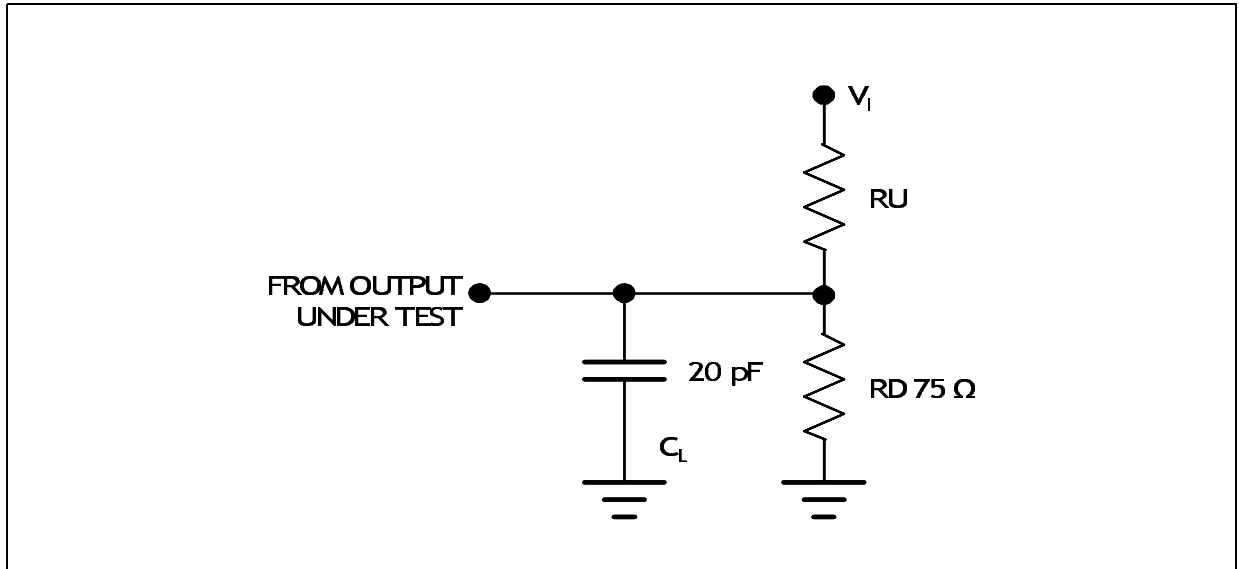
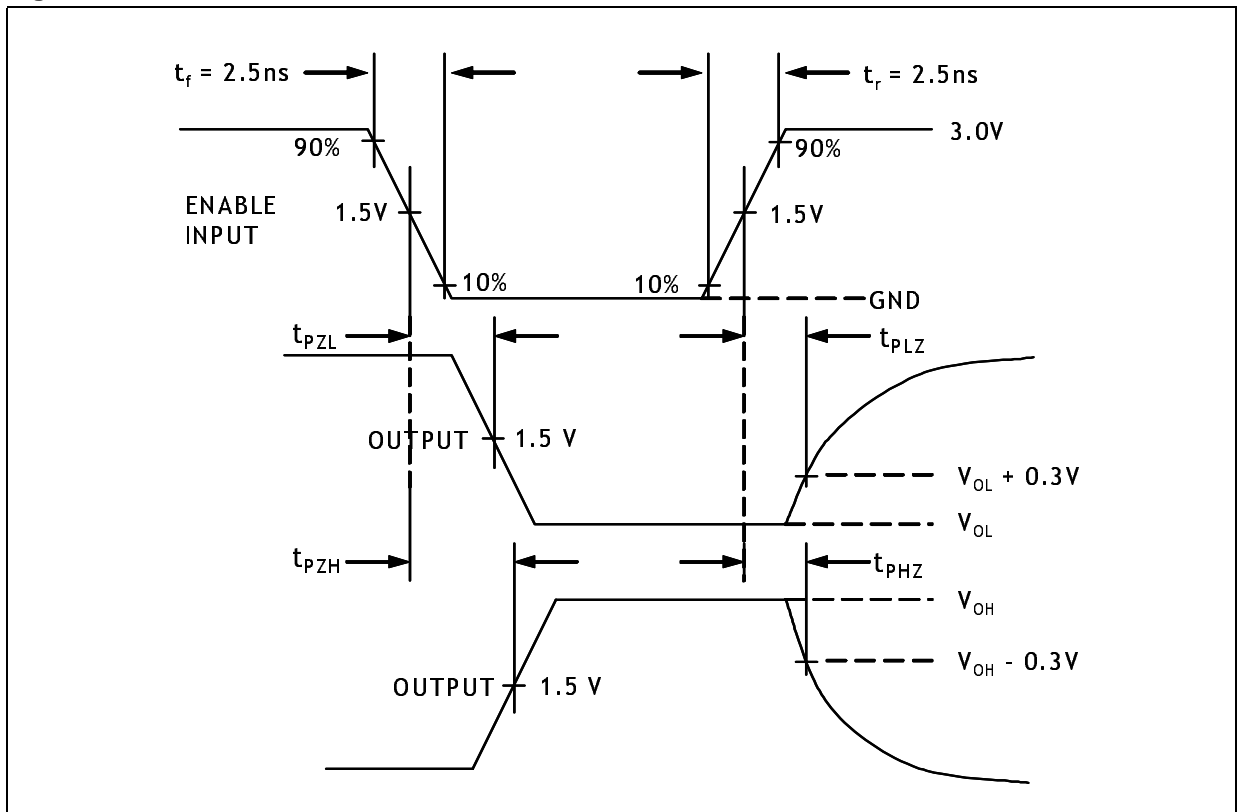

Figure 6. AC Waveforms



7 Test Circuits

Figure 7. Test Circuit to measure the on-resistance of the switch

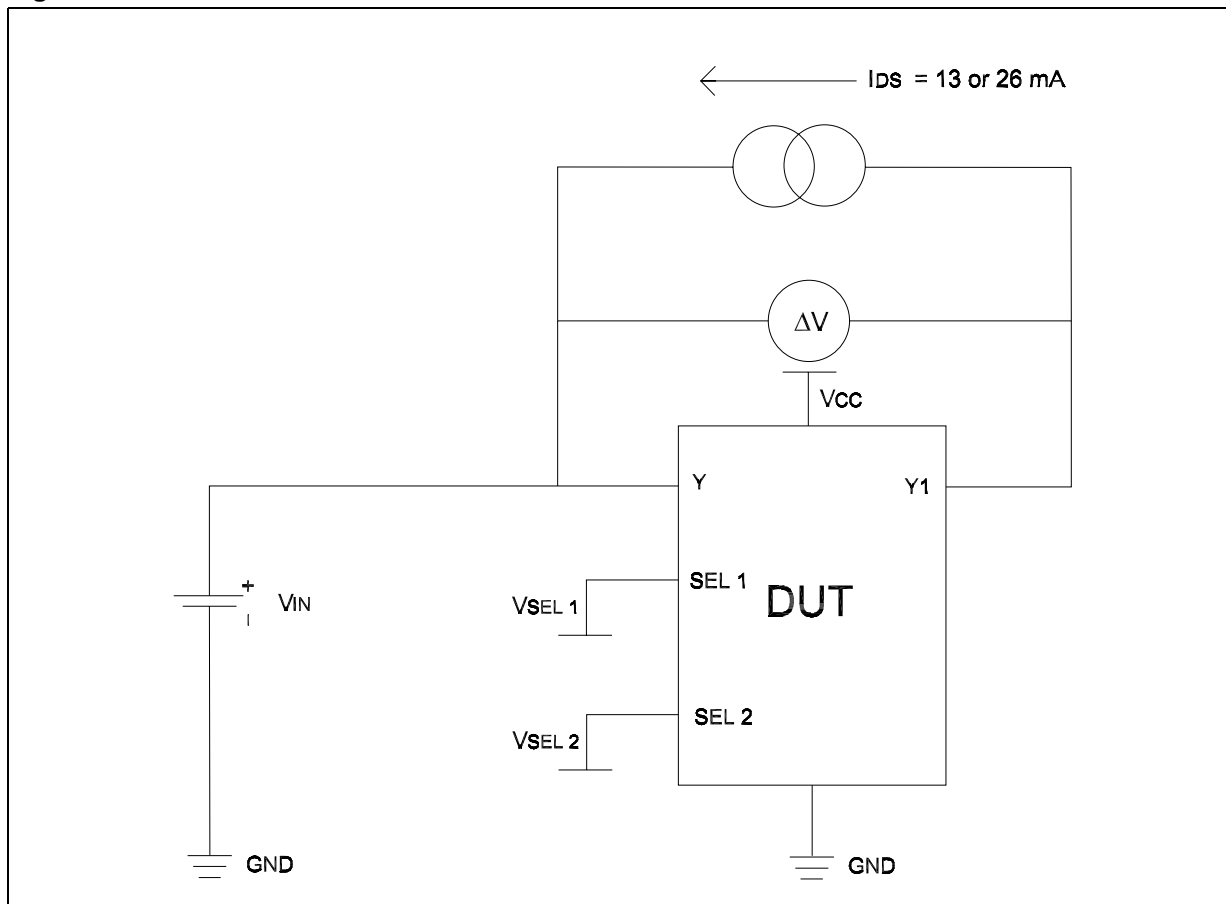

Figure 8. Enable/Disable Circuit and Timing Diagram

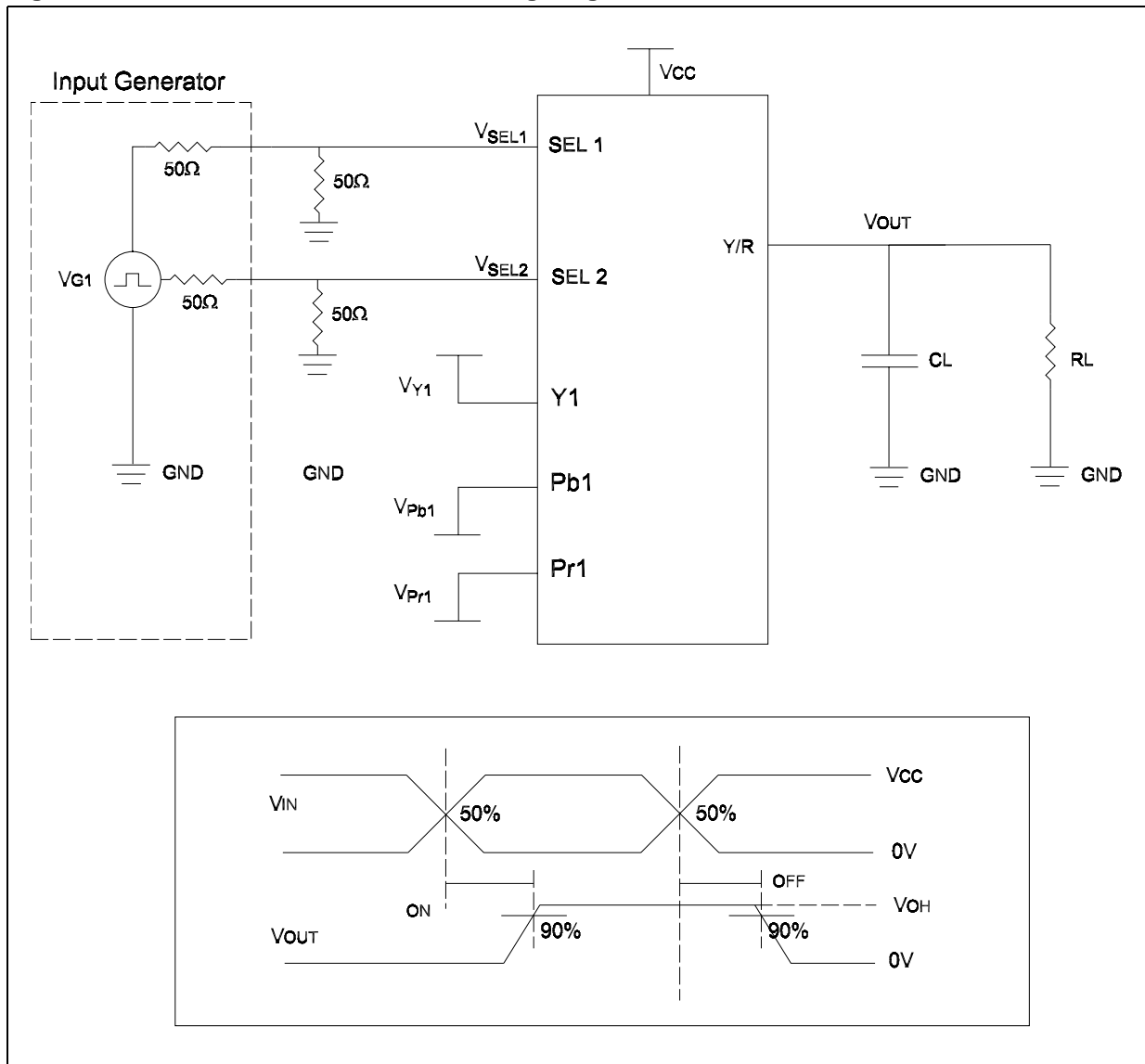

Table 8. Test Circuit

Test	V _{CC}	R _L	C _L	V _{Y1}	V _{Pb1}	V _{Pr1}
Enable time (tpZL, tpZH)	4.75V ± 0.75V	75	20	GND	GND	V _{CC}
	4.75V ± 0.75V	75	20	GND	V _{CC}	GND
	4.75V ± 0.75V	75	20	V _{CC}	GND	GND
Disable Time (tpLZ, tpHZ)	4.75V ± 0.75V	75	20	GND	GND	V _{CC}
	4.75V ± 0.75V	75	20	GND	V _{CC}	GND
	4.75V ± 0.75V	75	20	V _{CC}	GND	GND

Note: 1 CL includes probe and jig capacitance.

2 All input pulses are supplied by generators having the following characteristics: PRR ≤ 10MHz, ZO = 50Ω, tr, tf = 2.5ns.

3 The outputs are measured one at a time, with one transition per measurement.

Differential gain and phase are measured at the output of the ON channel. For example, when SEL1, SEL2 = 0 and Y is the input, the output is measured at Y1.

Figure 9. Differential Gain/Phase Measurement Test Circuit

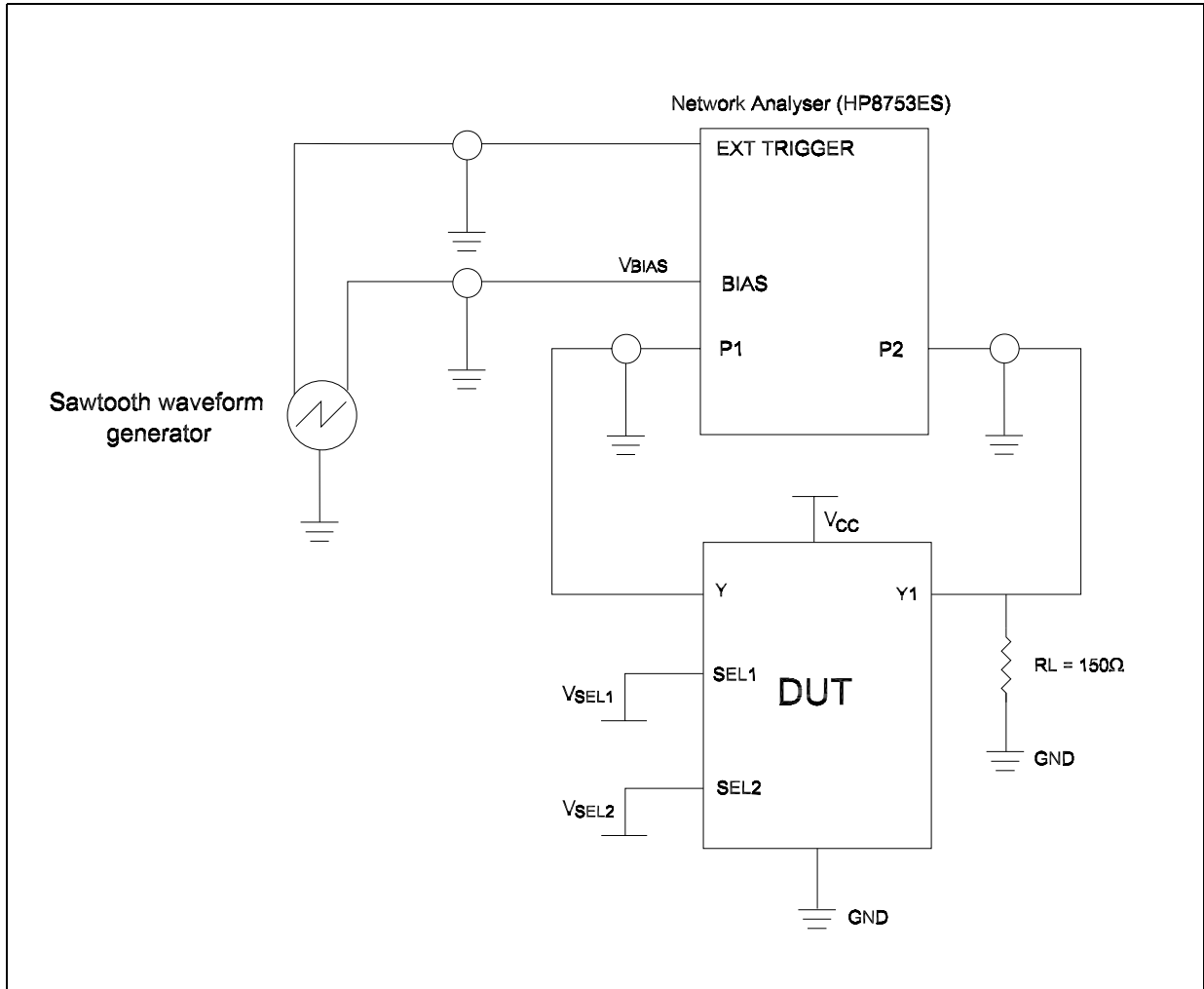

Frequency response is measured at the output of the ON channel. For example, when SEL1,SEL2 = 0, and Y is the input, the output is measured at Y1. All unused analog I/O ports are left open.

Figure 10. Test Circuit for frequency response (BW)

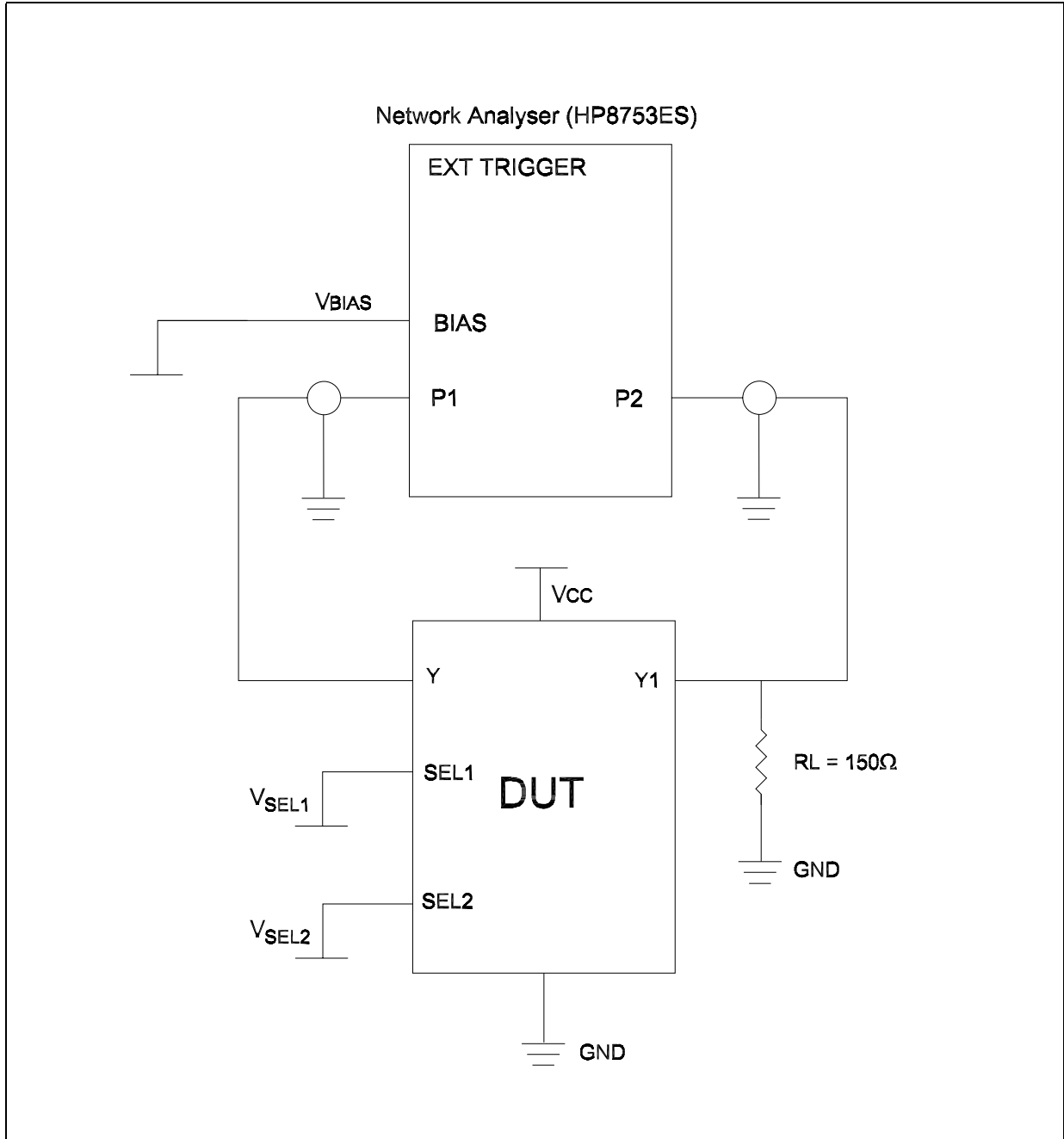

Crosstalk is measured at the output of the non-adjacent ON channel. For example, when SEL1,SEL2 = 0, and Y is the input, the output is measured at Pb1. All unused analog input ports (Pb,Pr) and output ports (PbX,PrX) are connected to GND through 10Ω and 50Ω pull-down resistors respectively.

Figure 11. Crosstalk Test Circuit

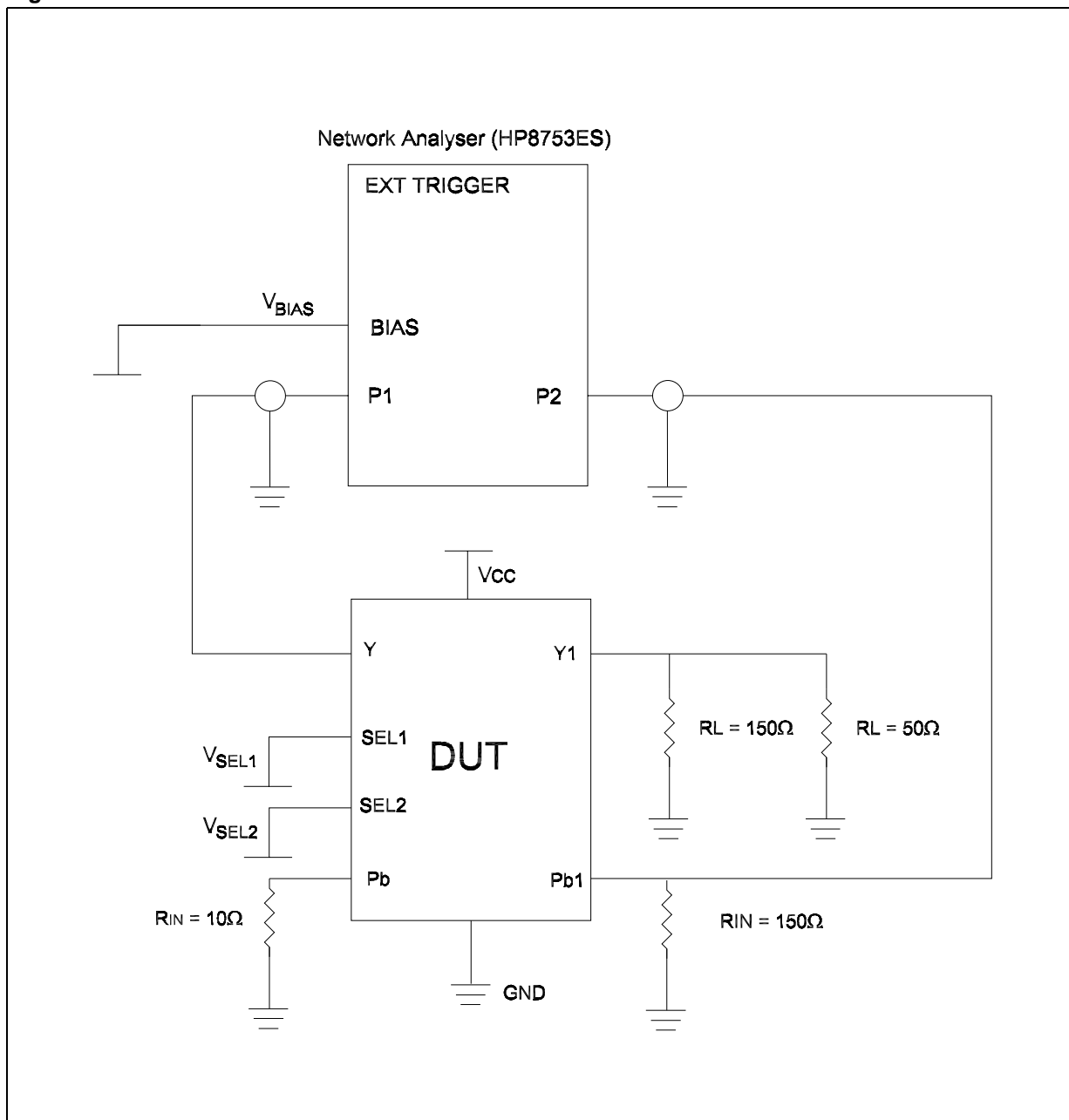

Note: 50Ω termination resistor is needed for the network analyzer.

Off-Isolation is measured at the output of the OFF channel. For example, when SEL1=0, SEL2=V_{CC}, and Y is the input, the output is measured at Y1. All unused analog input ports are left open, and output ports are connected to GND through 50Ω pull-down resistors.

Figure 12. Off-Isolation Test Circuit

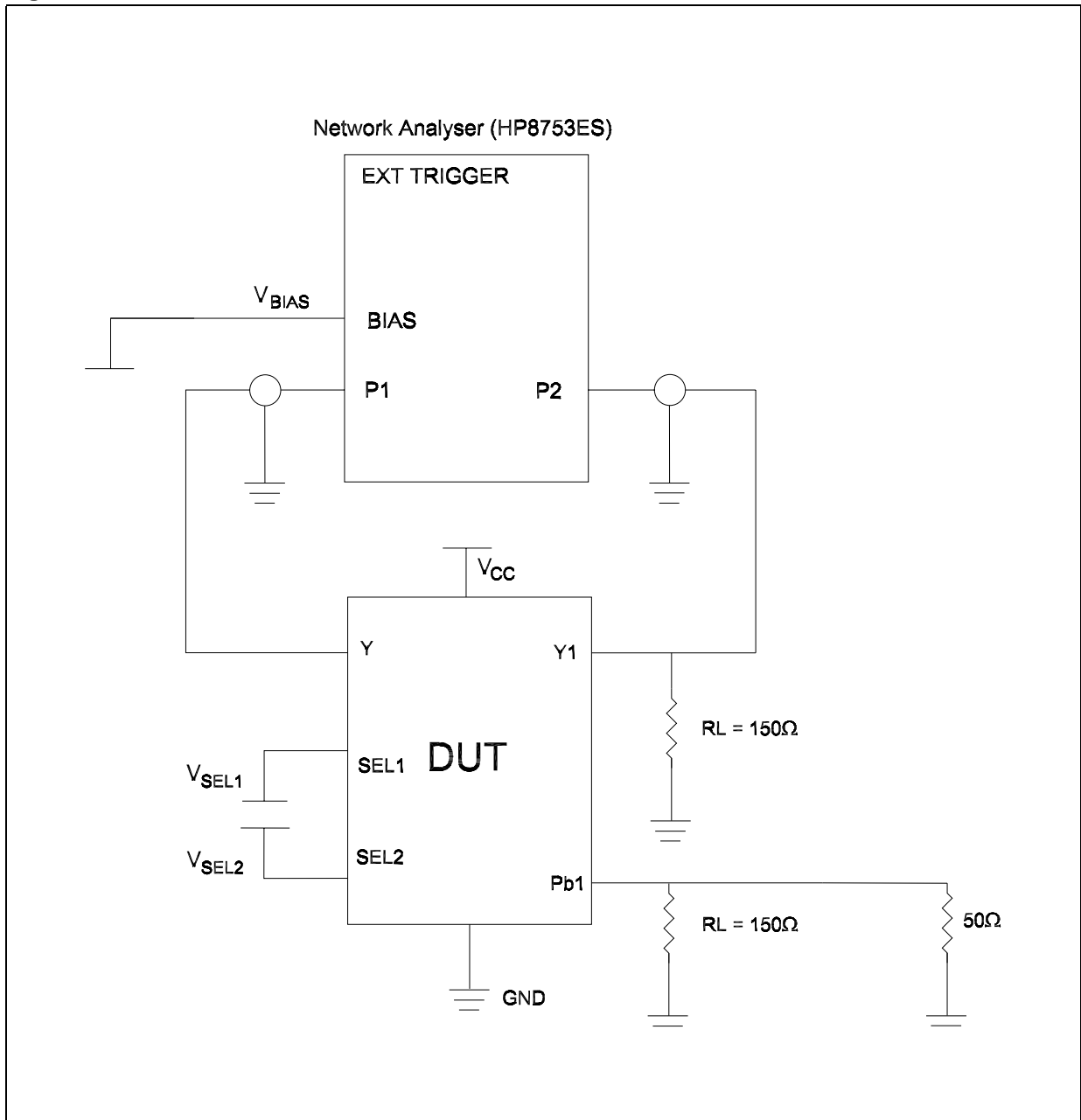

Note: 50Ω termination resistor is needed for the network analyzer.

Figure 13. ESD protection circuit for Input side of I/O pin

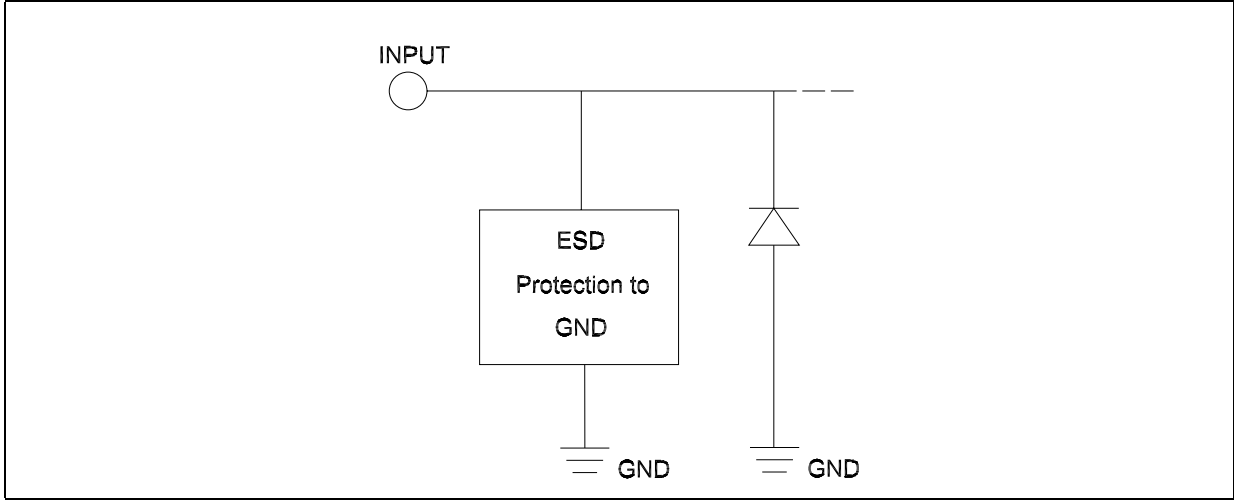

Figure 14. ESD protection circuit for Output side of I/O pin

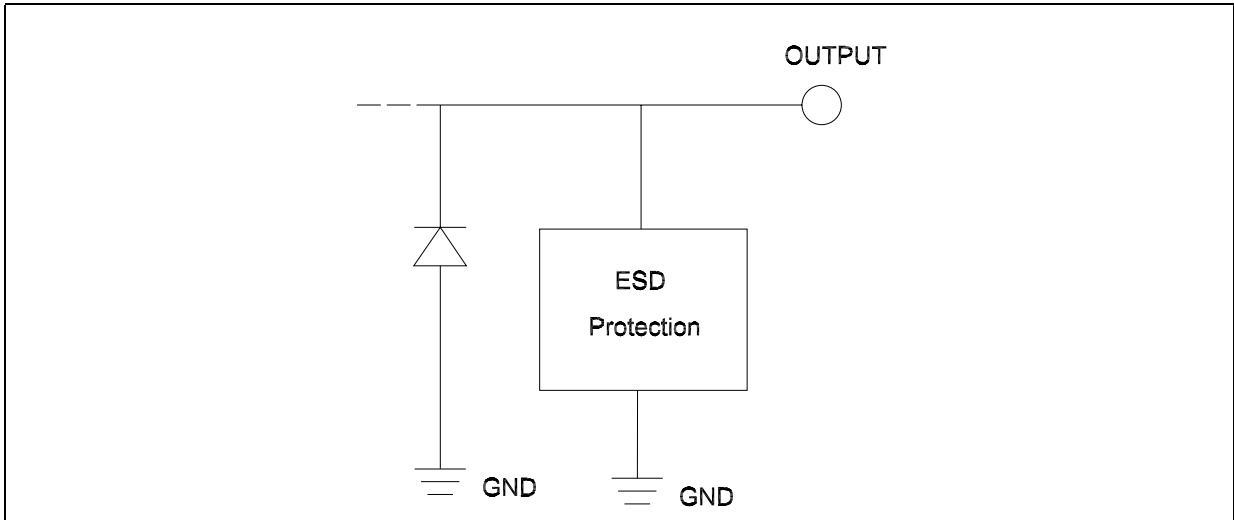
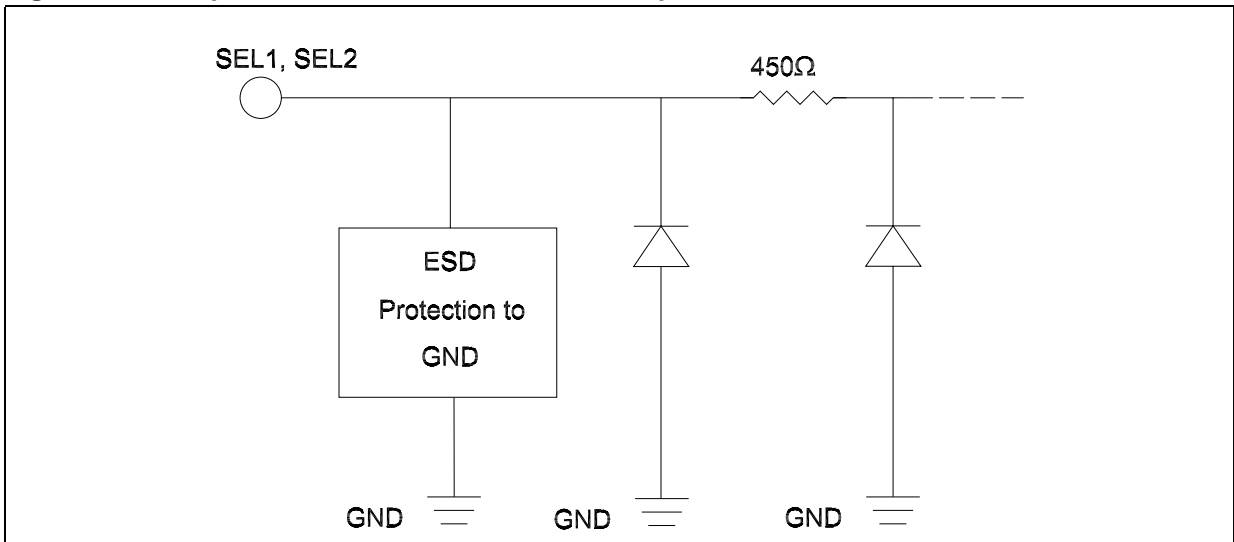

Figure 15. ESD protection circuit for SEL1, SEL2 inputs



8 Package Mechanical Data

In order to meet environmental requirements, ST offers these devices in ECOPACK[®] packages. These packages have a Lead-free second level interconnect . The category of second Level Interconnect is marked on the package and on the inner box label, in compliance with JEDEC Standard JESD97. The maximum ratings related to soldering conditions are also marked on the inner box label. ECOPACK is an ST trademark. ECOPACK specifications are available at: www.st.com.

TSSOP16 MECHANICAL DATA

DIM.	mm			inch		
	MIN.	TYP.	MAX.	MIN.	TYP.	MAX.
A			1.1			0.433
A1	0.05	0.10	0.15	0.002	0.004	0.006
A2	0.85	0.9	0.95	0.335	0.354	0.374
b	0.19		0.30	0.0075		0.0118
c	0.09		0.20	0.0035		0.0079
D	4.9	5	5.1	0.193	0.197	0.201
E	6.25	6.4	6.5	0.246	0.252	0.256
E1	4.3	4.4	4.48	0.169	0.173	0.176
e		0.65 BSC			0.0256 BSC	
K	0°	4°	8°	0°	4°	8°
L	0.50	0.60	0.70	0.020	0.024	0.028

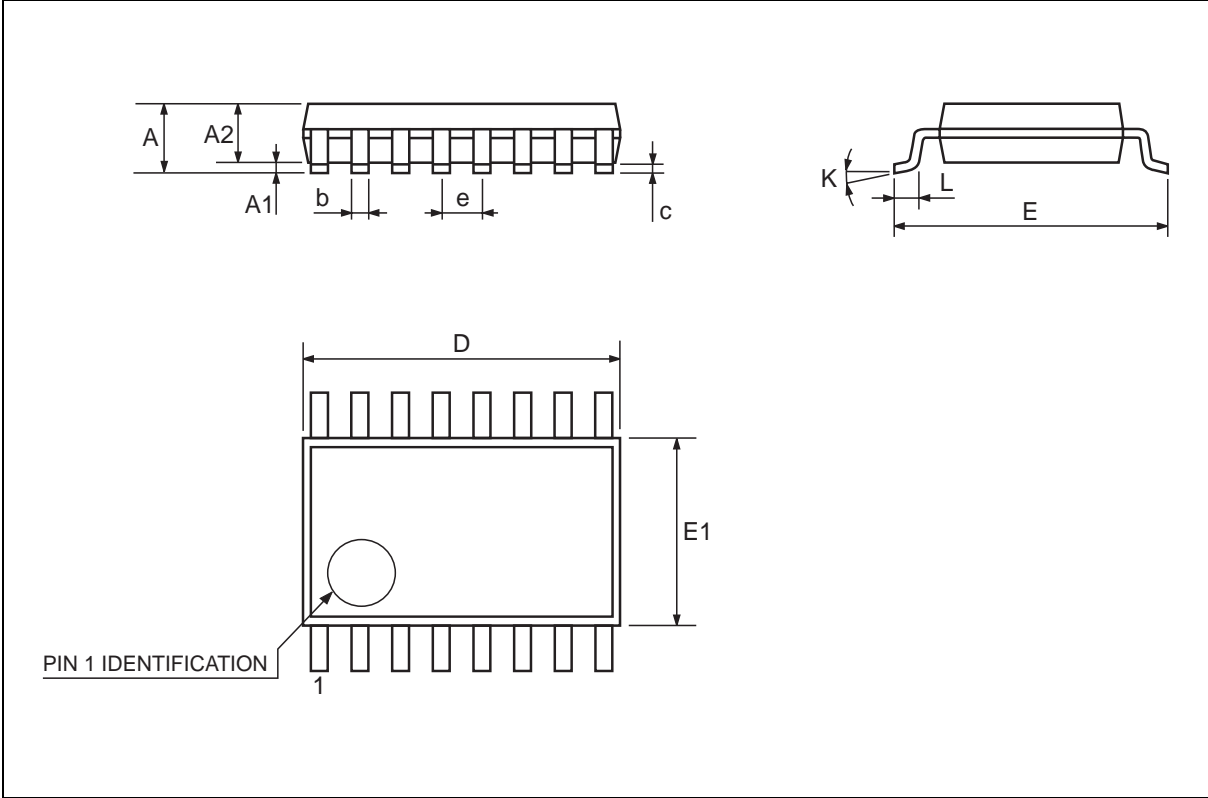

Tape & Reel TSSOP16 MECHANICAL DATA

DIM.	mm.			inch		
	MIN.	TYP	MAX.	MIN.	TYP.	MAX.
A			330			12.992
C	12.8		13.2	0.504		0.519
D	20.2			0.795		
N	60			2.362		
T			22.4			0.882
Ao	6.7		6.9	0.264		0.272
Bo	5.3		5.5	0.209		0.217
Ko	1.6		1.8	0.063		0.071
Po	3.9		4.1	0.153		0.161
P	7.9		8.1	0.311		0.319

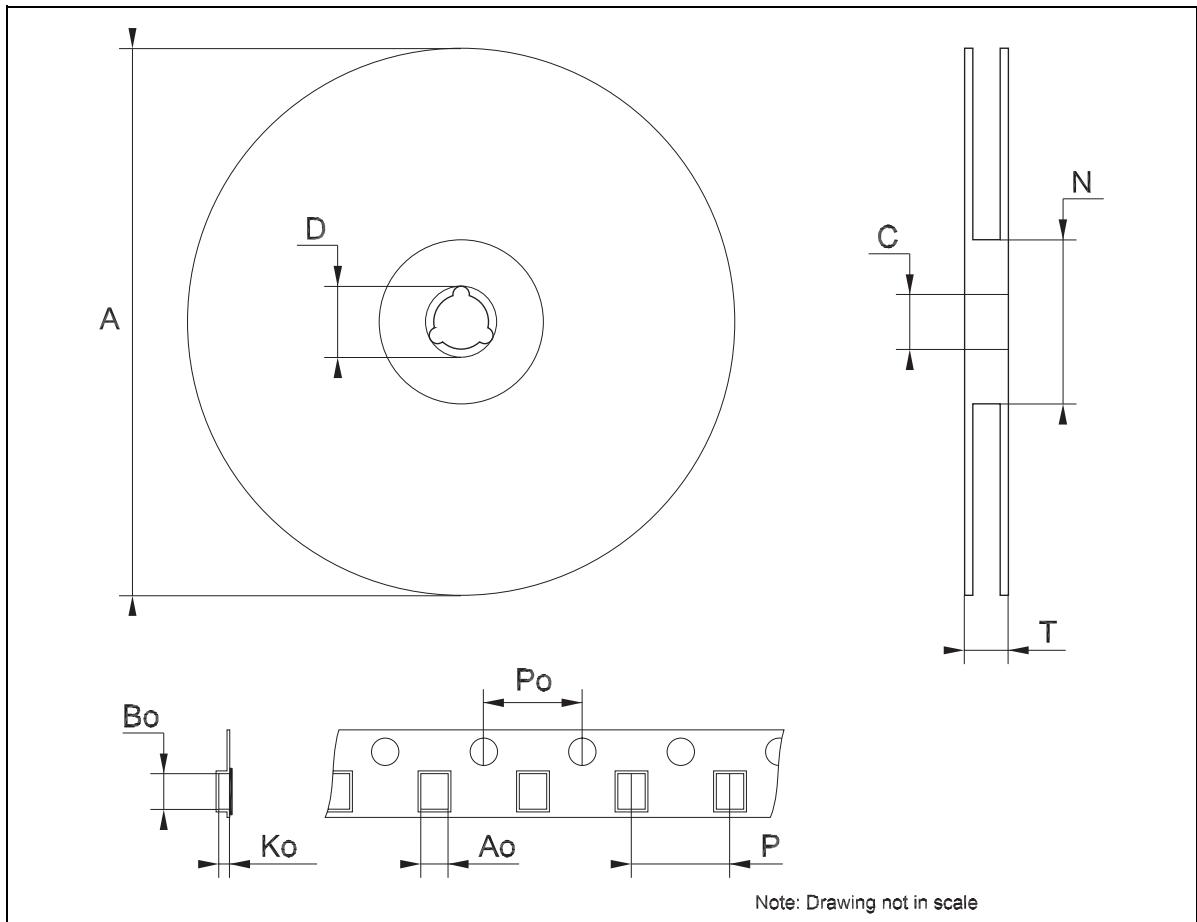

9 Revision History

Date	Revision	Description of Change
23-Jan-2006	1	First Release

Information furnished is believed to be accurate and reliable. However, STMicroelectronics assumes no responsibility for the consequences of use of such information nor for any infringement of patents or other rights of third parties which may result from its use. No license is granted by implication or otherwise under any patent or patent rights of STMicroelectronics. Specifications mentioned in this publication are subject to change without notice. This publication supersedes and replaces all information previously supplied. STMicroelectronics products are not authorized for use as critical components in life support devices or systems without express written approval of STMicroelectronics.

The ST logo is a registered trademark of STMicroelectronics.
All other names are the property of their respective owners

© 2006 STMicroelectronics - All rights reserved

STMicroelectronics group of companies

Australia - Belgium - Brazil - Canada - China - Czech Republic - Finland - France - Germany - Hong Kong - India - Israel - Italy - Japan -
Malaysia - Malta - Morocco - Singapore - Spain - Sweden - Switzerland - United Kingdom - United States of America

www.st.com

