

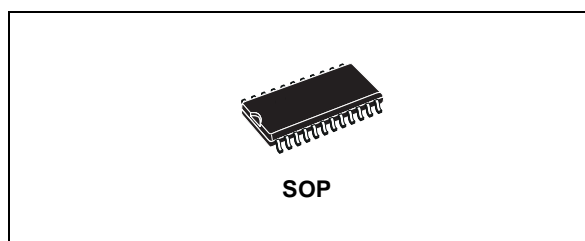

# HCF4097B

## ANALOG DIFFERENTIAL 8 CHANNEL MULTIPLEXER/DEMULTIPLEXER

- LOW ON RESISTANCE : 125Ω (Typ.) OVER 15V p-p SIGNAL INPUT RANGE FOR  $V_{DD} - V_{SS} = 15V$
- HIGH OFF RESISTANCE : CHANNEL LEAKAGE OF 10pA (Typ.) at  $V_{DD} - V_{SS} = 10V$
- MATCHED SWITCH CHARACTERISTICS :  $\Delta R_{ON} = 5\Omega$  (Typ.) FOR  $V_{DD} - V_{SS} = 15V$
- VERY LOW QUIESCENT POWER DISSIPATION UNDER A DIGITAL CONTROL INPUT AND SUPPLY CONDITIONS : 0.2μW (Typ.) at  $V_{DD} - V_{SS} = 10V$
- BINARY ADDRESS DECODING ON CHIP
- QUIESCENT CURRENT SPECIFIED UP TO 20V
- STANDARDIZED SYMMETRICAL OUTPUT CHARACTERISTICS
- 5V, 10V AND 15V PARAMETRIC RATINGS
- INPUT LEAKAGE CURRENT  $I_l = 100nA$  (MAX) AT  $V_{DD} = 18V$   $T_A = 25^\circ C$
- 100% TESTED FOR QUIESCENT CURRENT
- MEETS ALL REQUIREMENTS OF JEDEC JESD13B "STANDARD SPECIFICATIONS FOR DESCRIPTION OF B SERIES CMOS DEVICES"



### ORDER CODES

PACKAGE	TUBE	T & R
SOP	HCF4097BM1	HCF4097M013TR

HCF4097B, a analog multiplexer/demultiplexer CMOS, is a digitally controlled analog switches device having low ON impedance, low OFF leakage current and internal address decoding. in addition, the ON resistance is relatively constant over the full input-signal range. HCF4097B is a differential 8-channel multiplexer having three binary control inputs A, B, C, and an inhibit input. The inputs permit selection of one of eight pairs of switches. A logic "1" present at the inhibit input turns all channels off.

### DESCRIPTION

HCF4097B is monolithic integrated circuits fabricated in Metal Oxide Semiconductor technology available in SOP package.

### PIN CONNECTION

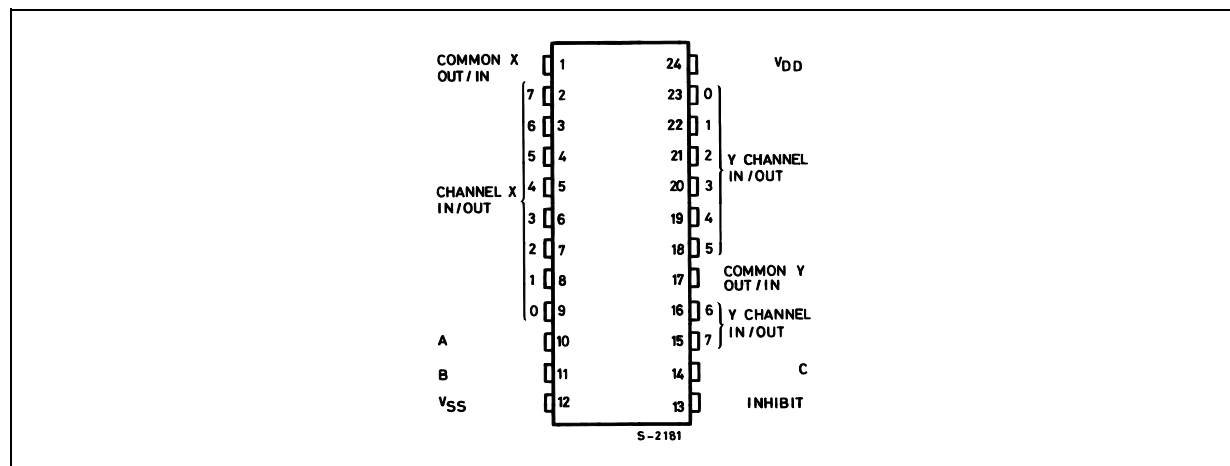

INPUT EQUIVALENT CIRCUIT

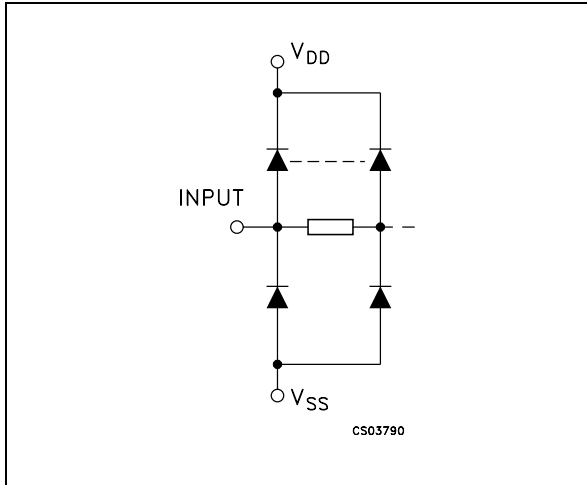

PIN DESCRIPTION

PIN No	SYMBOL	NAME AND FUNCTION
10, 11, 14	A, B, C	Binary Control Inputs
1	COMMON X OUT/IN	Common X Out/In
17	COMMON Y OUT/IN	Common Y Out/In
13	INHIBIT	Inhibit Input
9, 8, 7, 6, 5, 4, 3, 2	0 to 7 CHAN- NEL IN/OUT X	8 X channel In/Out
23, 22, 21, 20, 19, 18, 16, 15	0 to 7 CHAN- NEL IN/OUT Y	8 Y channel In/Out
12	V <sub>SS</sub>	Negative Supply Voltage
24	V <sub>DD</sub>	Positive Supply Voltage

FUNCTIONAL DIAGRAM

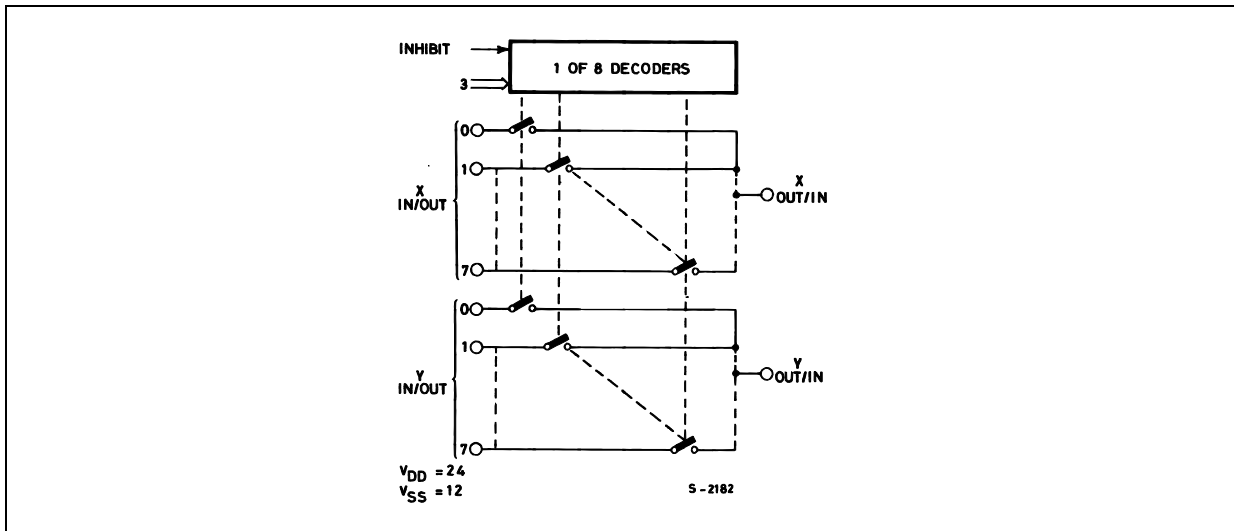

TRUTH TABLE

A	B	C	INH	SELECTED CHANNEL
X	X	X	H	NONE
L	L	L	L	0X 0Y
H	L	L	L	1X 1Y
L	H	L	L	2X 2Y
H	H	L	L	3X 3Y
L	L	H	L	4X 4Y
H	L	H	L	5X 5Y
L	H	H	L	6X 6Y
H	H	H	L	7X 7Y

LOGIC DIAGRAM

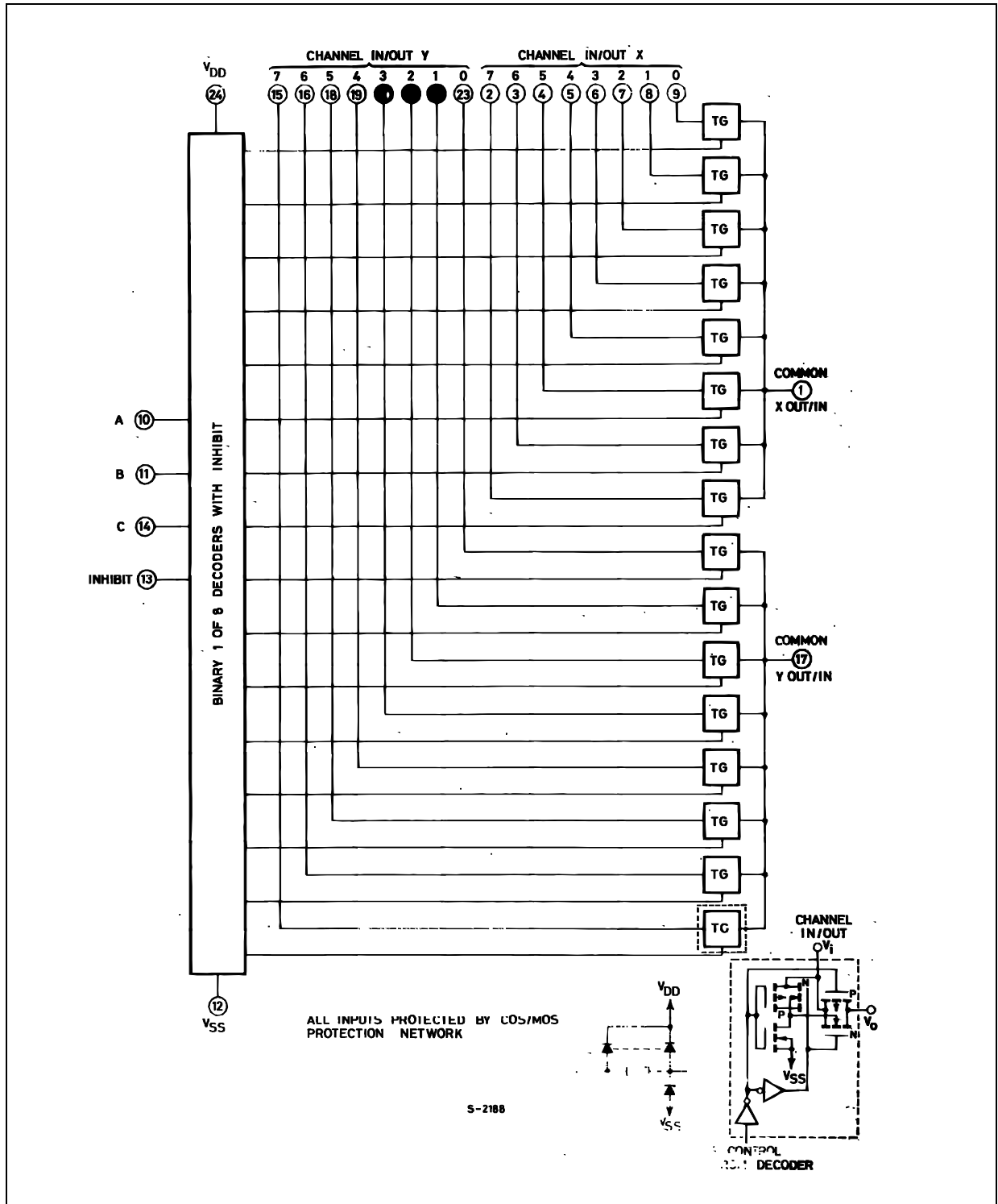

**ABSOLUTE MAXIMUM RATINGS**

Symbol	Parameter	Value	Unit
$V_{DD}$	Supply Voltage	-0.5 to +22	V
$V_I$	DC Input Voltage	-0.5 to $V_{DD} + 0.5$	V
$I_I$	DC Input Current	$\pm 10$	mA
$P_D$	Power Dissipation per Package	200	mW
	Power Dissipation per Output Transistor	100	mW
$T_{op}$	Operating Temperature	-55 to +125	°C
$T_{stg}$	Storage Temperature	-65 to +150	°C

Absolute Maximum Ratings are those values beyond which damage to the device may occur. Functional operation under these conditions is not implied.

All voltage values are referred to  $V_{SS}$  pin voltage.

**RECOMMENDED OPERATING CONDITIONS**

Symbol	Parameter	Value	Unit
$V_{DD}$	Supply Voltage	3 to 20	V
$V_I$	Input Voltage	0 to $V_{DD}$	V
$T_{op}$	Operating Temperature	-55 to 125	°C

**STATIC ELECTRICAL CHARACTERISTICS**(T<sub>amb</sub> = 25°C, Typical temperature coefficient for all V<sub>DD</sub> value is 0.3 %/°C)

Symbol	Parameter	Test Condition				Value						Unit	
		V <sub>IS</sub> (V)	V <sub>EE</sub> (V)	V <sub>SS</sub> (V)	V <sub>DD</sub> (V)	T <sub>A</sub> = 25°C			-40 to 85°C		-55 to 125°C		
						Min.	Typ.	Max.	Min.	Max.	Min.		Max.
I <sub>L</sub>	Quiescent Supply Current				5		0.04	5		150		150	μA
					10		0.04	10		300		300	
					15		0.04	20		600		600	
					20		0.08	100		3000		3000	
<b>SWITCH</b>													
R <sub>ON</sub>	On Resistance	0 ≤ V <sub>I</sub> ≤ V <sub>DD</sub>	0	0	5		470	1050		1200		1200	Ω
					10		180	400		500		520	
					15		125	240		300		300	
Δ <sub>ON</sub>	Resistance Δ <sub>RON</sub> (between any 2 of 4 switches)		0	0	5		10						Ω
					10		10						
					15		5						
OFF (•)	Channel Leakage Current Any Channel Off		0	0	18		±0.1	100		1000		1000	μA
	Channel Leakage Current All Channel Off (Common Out/In)		0	0	18		±0.1	100		1000		1000	
C	Capacitance Input						5						pF
	Output capacitance			-5	5		35						
	Feedthrough						0.2						
<b>CONTROL</b>													
V <sub>IL</sub>	Input Low Voltage	= V <sub>DD</sub> thru 1KΩ	V <sub>EE</sub> = V <sub>SS</sub> R <sub>L</sub> = 1KΩ to V <sub>SS</sub> I <sub>IS</sub> < 2μA (on all OFF channels)	5			1.5		1.5		1.5		V
				10			3		3		3		
				15			4		4		4		
V <sub>IH</sub>	Input High Voltage			5	3.5			3.5		3.5			V
				10	7			7		7			
				15	11			11		11			
I <sub>I</sub>	Input Leakage Current		V <sub>I</sub> = 0/18V		18		±10 <sup>-3</sup>	±0.1		±1		±1	μA
C <sub>I</sub>	Input Capacitance	Any Address or Inhibit Input					5	7.5					pF

The Noise Margin for both "1" and "0" level is: 1V min. with V<sub>DD</sub>=5V, 2V min. with V<sub>DD</sub>=10V, 2.5V min. with V<sub>DD</sub>=15V

• Determined by minimum feasible leakage measurement for automating testing

# HCF4097B

## DYNAMIC ELECTRICAL CHARACTERISTICS (T<sub>amb</sub> = 25°C, C<sub>L</sub> = 50pF, R<sub>L</sub> = 200KΩ, t<sub>r</sub> = t<sub>f</sub> = 20 ns)

Symbol	Parameter	Test Condition						Value*		Unit
		V <sub>C</sub> (V)	R <sub>L</sub> (KΩ)	f <sub>I</sub> (KHz)	V <sub>I</sub> (V)	V <sub>SS</sub> (V)	V <sub>DD</sub> (V)	Typ.	Max.	
<b>SWITCH</b>										
t <sub>pd</sub>	Propagation Delay Time (Signal Input to Output)	= V <sub>DD</sub>	200			0	5 10 15	30 15 11	60 30 20	ns
	Frequency Response Channel "ON" (Sine Wave Input) at 20 Log $\frac{V_O}{V_I} = -3dB$	= V <sub>DD</sub>	1		5 (•)	0	10	V <sub>O</sub> at Common Out/In 60	20	ns
	Feedthrough (All channels OFF) at 20 Log $\frac{V_O}{V_I} = -40dB$	= V <sub>SS</sub>	1		5 (•)	0	10	V <sub>O</sub> at Common Out/In 8	12	MHz
	Frequency Signal Crosstalk at 20 Log $\frac{V_{O(A)}}{V_{I(B)}} = -40dB$	V <sub>C(A)</sub> = V <sub>DD</sub> V <sub>C(B)</sub> = V <sub>SS</sub>	1		5 (•)	0	10	Between Any two (A and B) Channels 10 18	1	MHz
t <sub>w</sub>	Sine Wave Distortion (f <sub>IS</sub> = 1KHz sine wave)	5 10 15	10	1	2 (•) 3 (•) 5 (•)	0	5 10 15	0.3 0.2 0.12		%
<b>CONTROL (Address or Inhibit)</b>										
t <sub>PLH</sub> , t <sub>PHL</sub>	Propagation Delay Time: Address or Inhibit to Signal OUT (Channel Turning ON)		1			0	5 10 15	325 135 95	650 270 190	ns
t <sub>PLH</sub> , t <sub>PHL</sub>	Propagation Delay Time: Address or Inhibit to Signal OUT (Channel Turning OFF)		0.3			0	5 10 15	220 90 65	440 180 130	ns
	Address or Inhibit to Signal Crosstalk		10**			0	10	75		mV peak

(\*) Typical temperature coefficient for all V<sub>DD</sub> value is 0.3 %/°C

(\*\*) : Both Ends of Channel

(•) : Peak to Peak voltage symmetrical about (V<sub>DD</sub> - V<sub>SS</sub>) / 2

### APPLICATION INFORMATION

In applications where separate power sources are used to drive  $V_{DD}$  and the signal inputs, the  $V_{DD}$  current capability should exceed  $V_{DD}/R_L$  ( $R_L$  = effective external load). This provision avoids permanent current flow or clamp action on the  $V_{DD}$  supply when power is applied or removed from the HCF4097B.

When switching from one address to another, some of the ON periods of the channels of the multiplexers will overlap momentarily, which may be objectionable in certain applications. Also, when a channel is turned ON or OFF by an address input, there is a momentary conductive path from the channel to  $V_{SS}$ , which will dump some charge from any capacitor connected to the input or output of the channel. The inhibit input turning on a channel will similarly dump some charge to  $V_{SS}$ .

The amount of charge dumped is mostly a function of the signal level above  $V_{SS}$ . Typically, at  $V_{DD} - V_{SS} = 10V$ , a 100 pF capacitor connected to

the input or output of the channel will lose 3-4% of its voltage at the moment the channel turns ON or OFF. This loss of voltage is essentially independent of the address or inhibit signal transition time, if the transition time is less than 1-2 ms. When the inhibit signal turns a channel off, there is no charge dumping of  $V_{SS}$ . Rather, there is a slight rise in the channel voltage level (65 mV typ.) due to the capacitance coupling from inhibit input to channel input or output. Address input also couple some voltage steps onto the channel signal levels.

In certain applications, the external load-resistor current may include both  $V_{DD}$  and signal line components. To avoid drawing  $V_{DD}$  current when switch current flows into the transmission gate inputs, the voltage drop across the bidirectional switch must not exceed 0.8V (calculated from  $R_{ON}$  values shown in ELECTRICAL CHARACTERISTICS CHART). No  $V_{DD}$  current will flow through  $R_L$  if the switch current flows into terminal 1 on the HCF4097B.

### TEST CIRCUIT

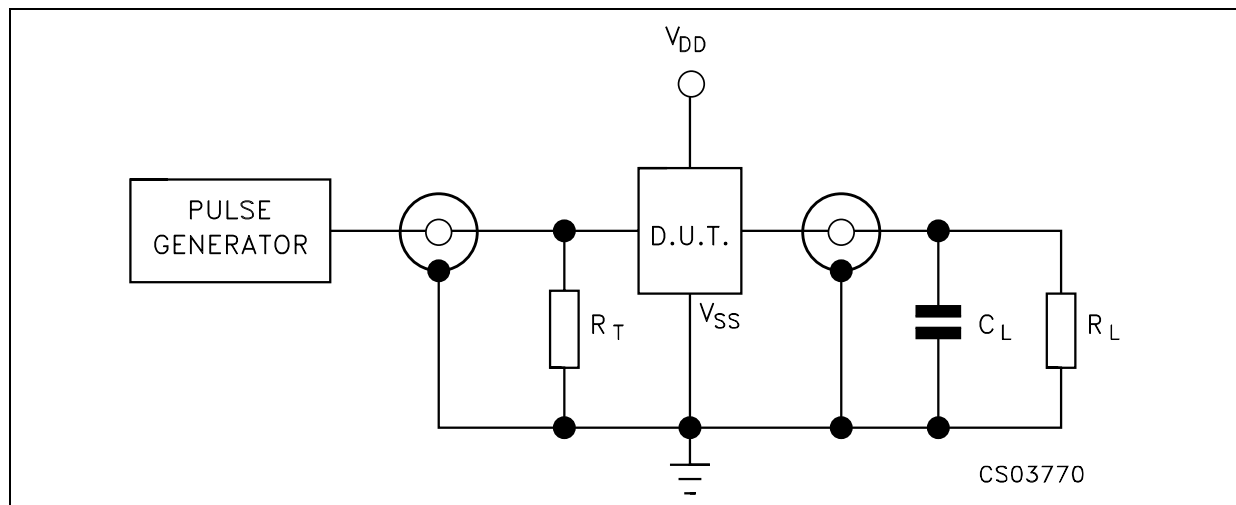

$C_L$  = 50pF or equivalent (includes jig and probe capacitance)

$R_L$  = 200K $\Omega$

$R_T$  =  $Z_{OUT}$  of pulse generator (typically 50 $\Omega$ )

WAVEFORM : PROPAGATION DELAY TIMES (f=1MHz; 50% duty cycle)

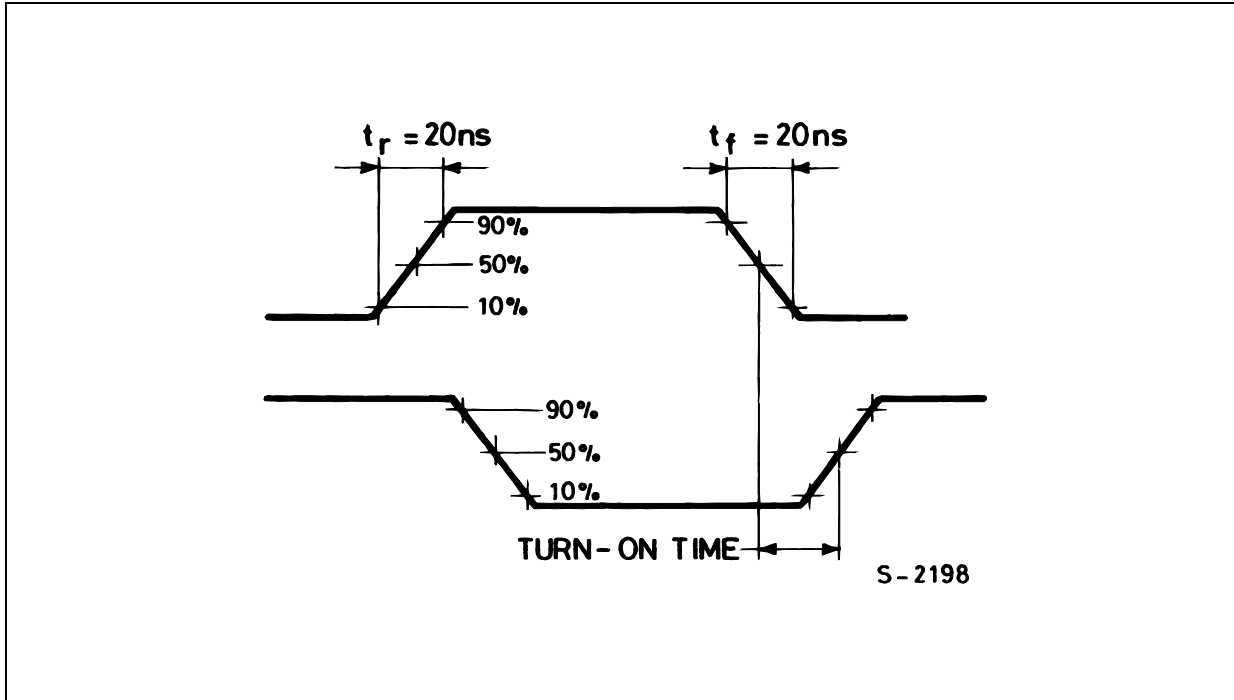

WAVEFORM : PROPAGATION DELAY TIMES (f=1MHz; 50% duty cycle)

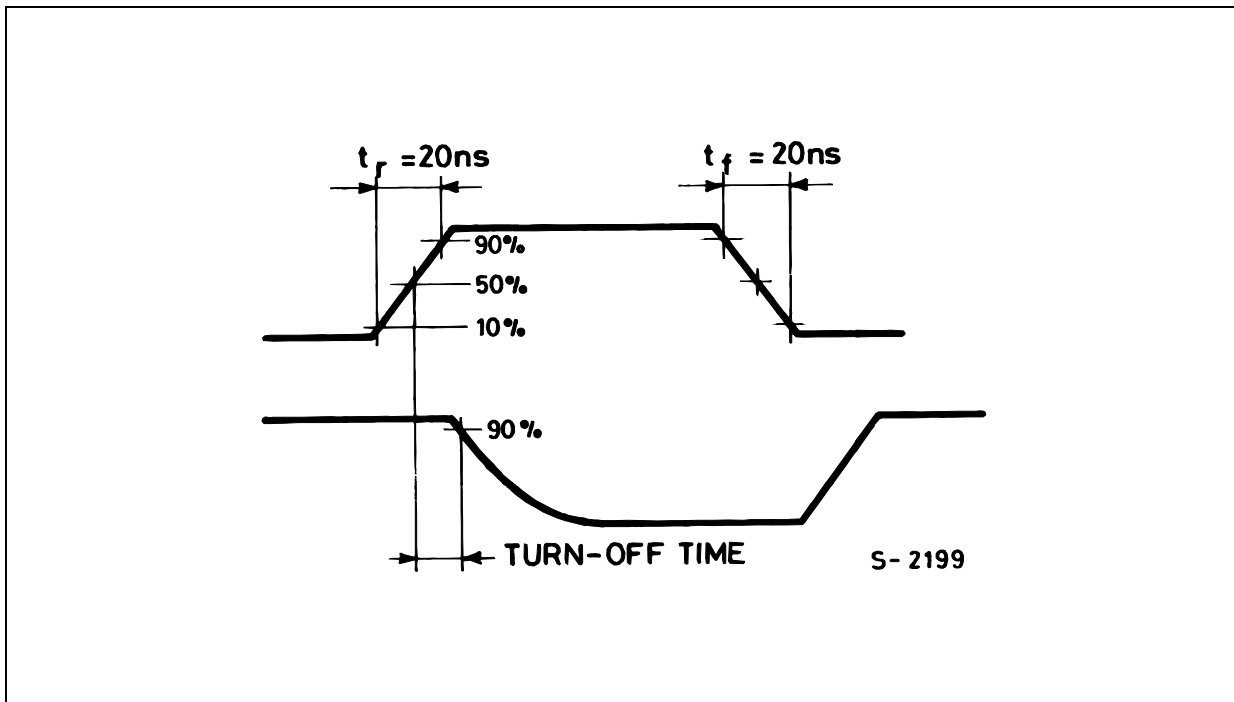

## SO-24 MECHANICAL DATA

DIM.	mm.			inch		
	MIN.	TYP	MAX.	MIN.	TYP.	MAX.
A			2.65			0.104
a1	0.1		0.2	0.004		0.008
a2			2.45			0.096
b	0.35		0.49	0.014		0.019
b1	0.23		0.32	0.009		0.012
C		0.5			0.020	
c1	45° (typ.)					
D	15.20		15.60	0.598		0.614
E	10.00		10.65	0.393		0.419
e		1.27			0.050	
e3		13.97			0.550	
F	7.40		7.60	0.291		0.300
L	0.50		1.27	0.020		0.050
S	8° (max.)					

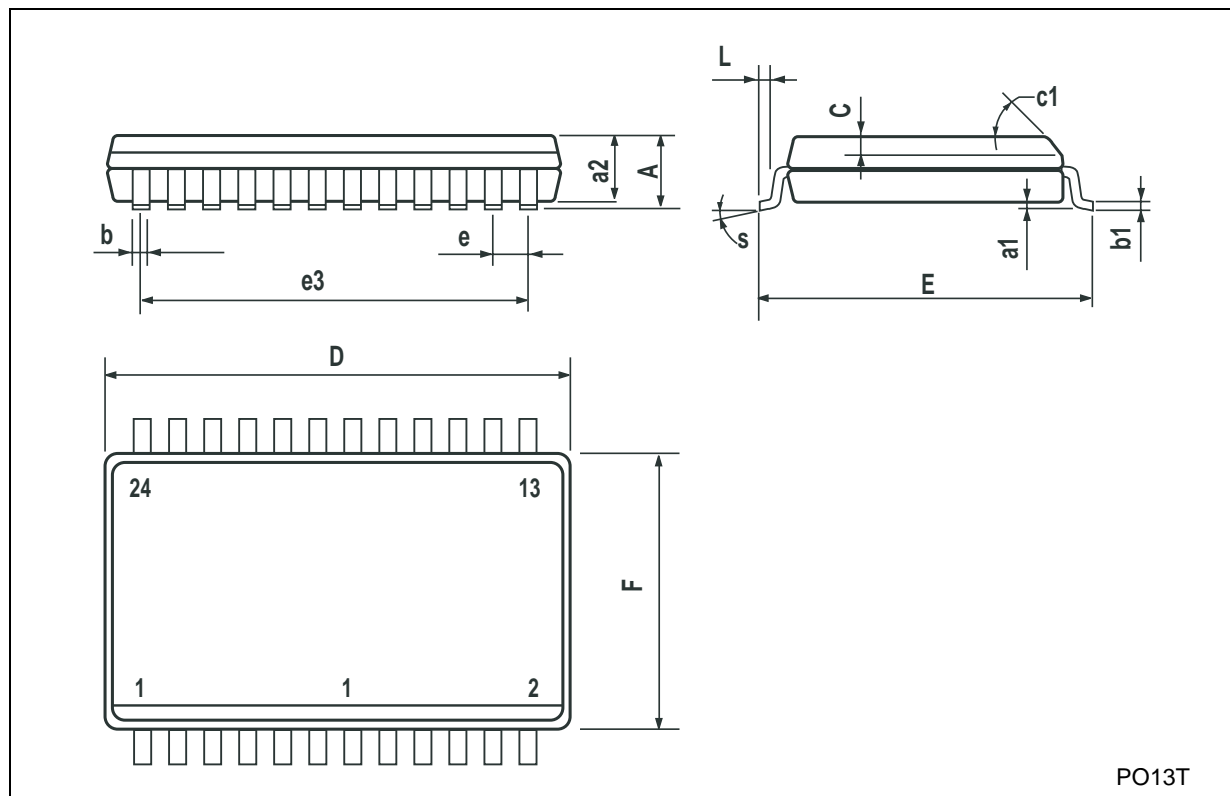

Information furnished is believed to be accurate and reliable. However, STMicroelectronics assumes no responsibility for the consequences of use of such information nor for any infringement of patents or other rights of third parties which may result from its use. No license is granted by implication or otherwise under any patent or patent rights of STMicroelectronics. Specifications mentioned in this publication are subject to change without notice. This publication supersedes and replaces all information previously supplied. STMicroelectronics products are not authorized for use as critical components in life support devices or systems without express written approval of STMicroelectronics.

© The ST logo is a registered trademark of STMicroelectronics

© 2002 STMicroelectronics - Printed in Italy - All Rights Reserved  
STMicroelectronics GROUP OF COMPANIES

Australia - Brazil - Canada - China - Finland - France - Germany - Hong Kong - India - Israel - Italy - Japan - Malaysia - Malta - Morocco  
Singapore - Spain - Sweden - Switzerland - United Kingdom - United States.

© <http://www.st.com>