

Single 8-channel analog MUX/DEMUX with injection current protection

Datasheet – production data

Features

- Low power dissipation:
 $I_{CC} = 2 \mu\text{A}$ (max.) at $T_A = 25 \text{ }^\circ\text{C}$
- Injection current protection:
 $V_{\Delta\text{OUT}} < 1 \text{ mV}$ at $V_{CC} = 5 \text{ V}$ $I_{IN} \leq 1 \text{ mA}$
 $R_S \leq 3.9 \text{ k}\Omega$
- "ON" resistance at $T_A = 25 \text{ }^\circ\text{C}$:
 215Ω typ. ($V_{CC} = 3.0 \text{ V}$)
 160Ω typ. ($V_{CC} = 4.5 \text{ V}$)
 150Ω typ. ($V_{CC} = 6 \text{ V}$)
- Fast switching:
 $t_{pd} = 8.6 \text{ ns}$ (typ.) at $T_A = 25 \text{ }^\circ\text{C}$, $V_{CC} = 4.5 \text{ V}$
- Wide operating supply voltage range:
 $V_{CC} = 2 \text{ V}$ to 6 V
- High noise immunity:
 $V_{NIH} = V_{NIL} = 28\% V_{CC}$ (min.)
- Pin and function compatible with series 4051, 4851
- Latch-up performance exceeds 500 mA (JESD 17)
- ESD performance:
 $\text{HBM} > 2000 \text{ V}$ JESD22-A111
 $\text{MM} > 200 \text{ V}$ JESD22-A115
 $\text{CDM} > 1000 \text{ V}$ JESD22-C101

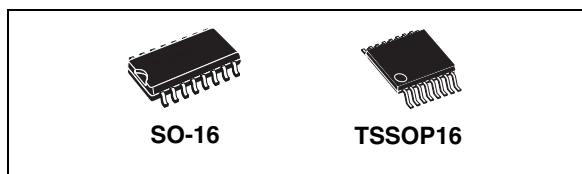

Applications

- Automotive
- Computer
- Consumer
- Industrial

Description

The M74HC4851 is a single 8-channel analog multiplexer/demultiplexer manufactured with silicon gate C2MOS technology.

It features injection current effect control which makes the device particularly suited for use in automotive applications where voltages in excess of normal logic voltages are common. The injection current effect control allows signals at disabled input channels to exceed the supply voltage range or go down to ground without affecting the signal of the enabled analog channel.

This eliminates the need for external diode-resistor networks typically used to keep the analog channel signals within the supply voltage range.

Table 1. Device summary

Order code	Temperature range	Package
M74HC4851YRM13TR ⁽¹⁾	-40/+125 °C	SO-16 (automotive grade)
M74HC4851RM13TR	-55/+125 °C	SO-16
M74HC4851YTTR ⁽¹⁾	-40/+125 °C	TSSOP16 (automotive grade)
M74HC4851TTR	-55/+125 °C	TSSOP16

1. Qualification and characterization (according to AEC Q100 and Q003 or equivalent) and advanced screening (according to AEC Q001 and Q002 or equivalent) are ongoing.

1 Pin connections

Figure 1. Pin connections and IEC logic symbols

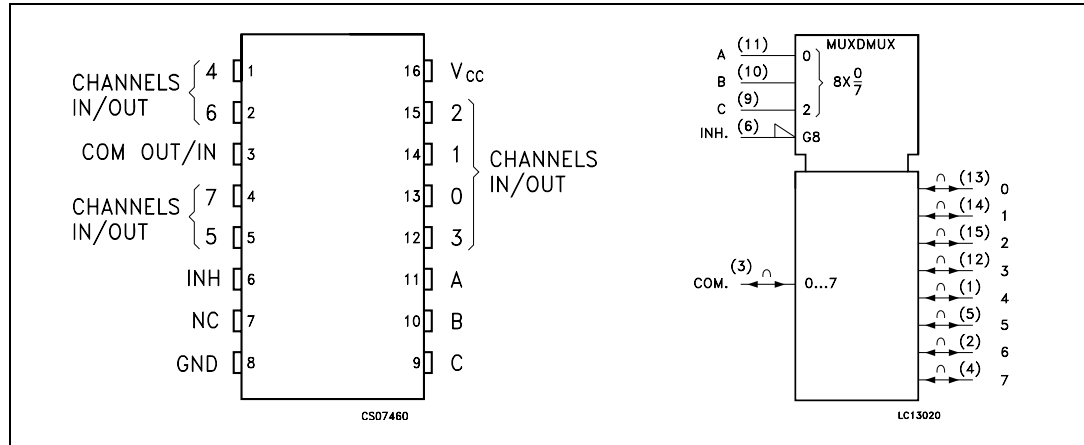

Table 2. Pin descriptions

Pin number	Symbol	Name and function
3	COM OUT/IN	Common output/input
6	INH	INHIBIT input
7	NC	Not connected
11, 10, 9	A, B, C	Select inputs
13, 14, 15, 12, 1, 5, 2, 4	0 to 7	Independent input/outputs
8	GND	Ground (0 V)
16	VCC	Positive supply voltage

Table 3. Truth table

Input state				On channel
INH	C	B	A	
L	L	L	L	0
L	L	L	H	1
L	L	H	L	2
L	L	H	H	3
L	H	L	L	4
L	H	L	H	5
L	H	H	L	6
L	H	H	H	7
H	X	X	X	NONE

Note: X: don't care.

Figure 2. Control input equivalent circuit

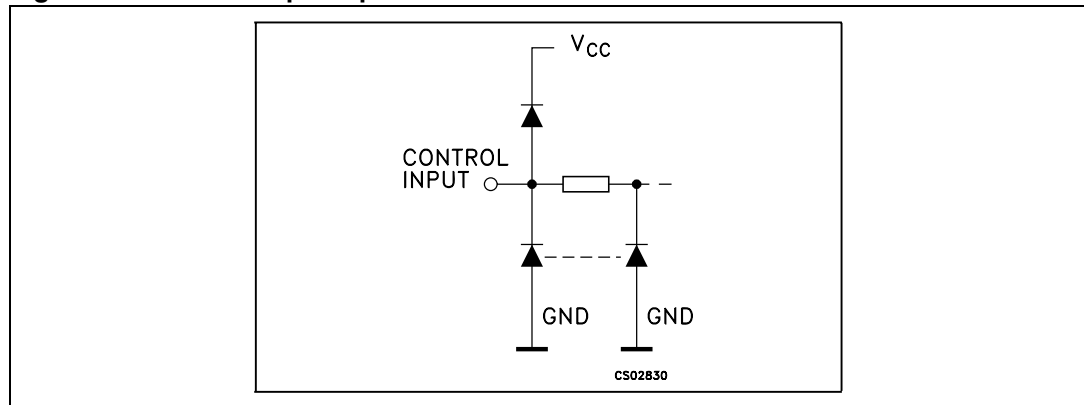

Figure 3. I/O equivalent circuit

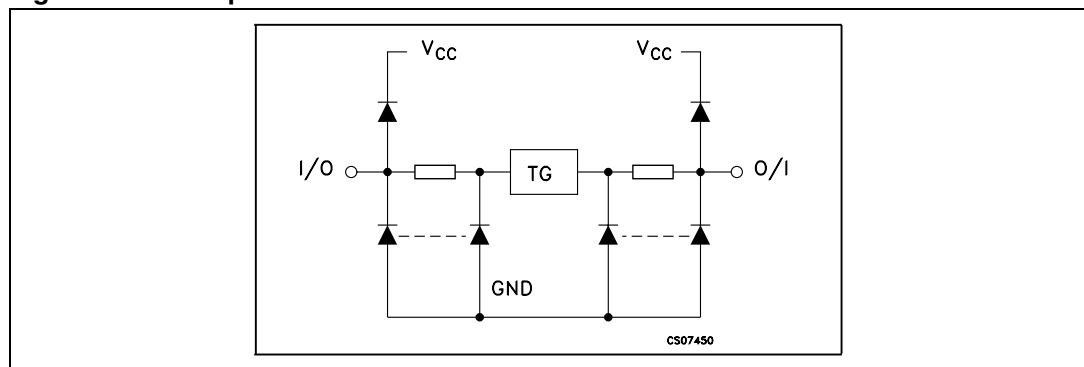
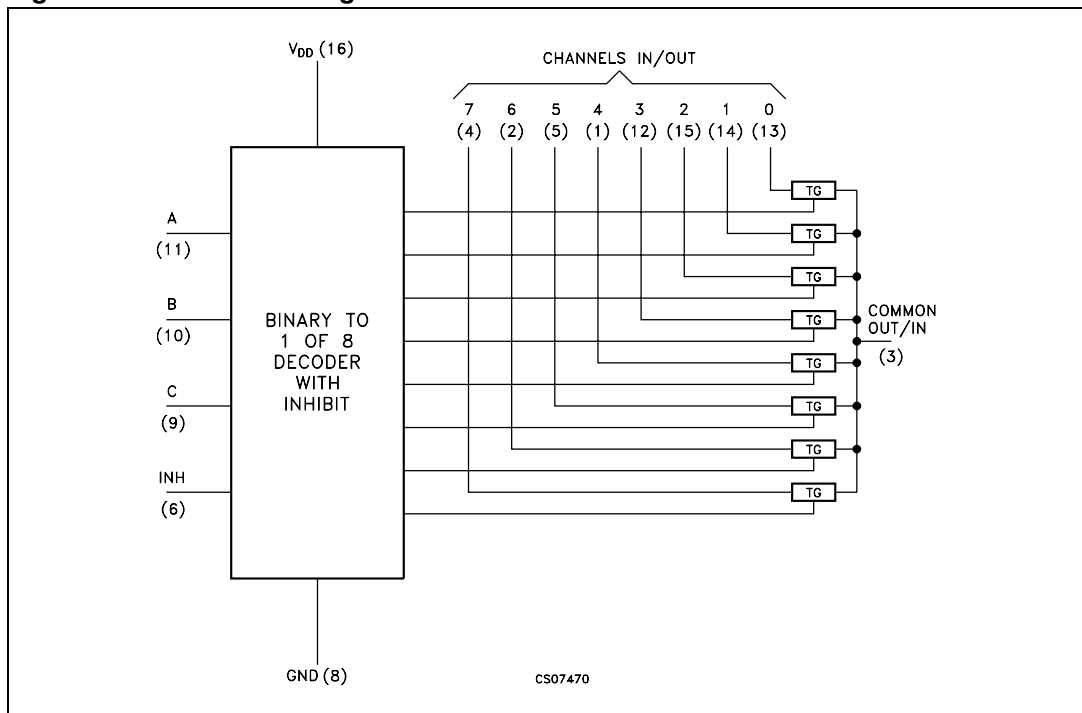

Figure 4. Functional diagram



2 Absolute maximum ratings and operating conditions

Note: Absolute maximum ratings are those values beyond which damage to the device may occur. Functional operation under these conditions is not implied.

Table 4. Absolute maximum ratings

Symbol	Parameter	Value	Unit
V_{CC}	Supply voltage	-0.5 to +7	V
V_{IN}	Control input voltage	-0.5 to $V_{CC} + 0.5$	V
$V_{I/O}$	Switch I/O voltage	-0.5 to $V_{CC} + 0.5$	V
I_{CK}	Control input diode current	± 25	mA
$I_{I/OK}$	I/O diode current	± 25	mA
I_{CC}	DC V_{CC} or ground current	± 50	mA
P_D	Power dissipation	SO-16	500 ⁽¹⁾ mW
		TSSOP16	450 ⁽¹⁾ mW
T_{stg}	Storage temperature	-65 to +150	°C
T_L	Lead temperature (10 sec)	300	°C
ESD (JESD22)	Human body model (HBM)	2000	V
	Machine model (MM)	200	V
	Charged device model (CDM)	1000	V

1. Power dissipation at 65 °C. Derating from 65 °C to 125 °C: SO package -7 mW/°C; TSSOP package -6.1 mW/°C.

Table 5. Recommended operating conditions

Symbol	Parameter	Value	Unit
V_{CC}	Supply voltage	2 to 6	V
$V_{I/O}$	Input output voltage	0 to V_{CC}	V
$V_{I/O}$	Static or dynamic voltage across switch ⁽¹⁾	0 to 1.2	V
V_{IN}	Control input voltage	0 to V_{CC}	V
T_{op}	Operating temperature	SO-16, TSSOP16	-55 to +125 °C
		SO-16, TSSOP16 (automotive grade)	-40 to +125 °C
t_r, t_f	Input rise and fall time ⁽²⁾ (channel select or enable inputs only)	$V_{CC} = 2.0$ V	0 to 1000 ns
		$V_{CC} = 3.0$ V	0 to 800 ns
		$V_{CC} = 3.3$ V	0 to 700 ns
		$V_{CC} = 4.5$ V	0 to 500 ns
		$V_{CC} = 6.0$ V	0 to 400 ns

1. For voltage drops across the switch greater than 1.2 V (switch on), excessive V_{CC} current may be drawn; i.e., the current out of the switch may contain both V_{CC} and switch input components. The reliability of the device is unaffected unless the maximum ratings are exceeded.

2. V_{IN} from 30% to 70% V_{CC} of channel Selected or Enable Inputs.

Table 6. DC specifications

Symbol	Parameter	Test condition		Value						Unit		
				T _A = 25 °C			Up to 85 °C		Up to 125 °C			
		V _{CC} (V)		Min.	Typ.	Max.	Min.	Max.	Min.		Max.	
V _{IHC}	High level input voltage	2.0		1.5			1.5		1.5		V	
		3.0		2.1			2.1		2.1			
		3.0		2.3			2.3		2.3			
		4.5		3.15			3.15		3.15			
		6.0		4.2			4.2		4.2			
V _{ILC}	Low level input voltage	2.0				0.5		0.5		0.5	V	
		3.0				0.9		0.9		0.9		
		3.3				1.0		1.0		1.0		
		4.5				1.35		1.35		1.35		
		6.0				1.8		1.8		1.8		
R _{ON}	ON resistance	2.0	I _S =2mA	V _{IN} = V _{IHC} or V _{ILC} V _{IS} = V _{CC} to GND		500	650		670		700	Ω
		3.0	I _S ≤2mA		215	280		320		360		
		3.3			210	270		305		345		
		4.5			160	210		240		270		
		6.0			150	195		220		250		
ΔR _{ON}	Difference of ON resistance between switches	2.0	I _S =2mA	V _{IN} = V _{IHC} or V _{ILC} V _{IS} = V _{CC} /2		4	10		15		20	Ω
		3.0	I _S ≤2mA		2	8		12		16		
		3.3			2	8		12		16		
		4.5			2	8		12		16		
		6.0			3	9		13		18		
I _{OFF}	Input/output leakage current (switch off) (any channel)	6.0	V _{IN} = V _{CC} or GND			±0.1		± 0.5		± 1.0	μA	
I _{OFF}	Input/output leakage current (switch off) (common channel)	6.0				± 0.2		± 2		± 4	μA	
I _{ON}	Switch input leakage current (switch on, output open)	6.0	V _{IN} = V _{CC} or GND			±0.1		± 0.5		± 1	μA	

Table 6. DC specifications (continued)

Symbol	Parameter	Test condition		Value						Unit	
		V _{CC} (V)		T _A = 25 °C			Up to 85 °C		Up to 125 °C		
				Min.	Typ.	Max.	Min.	Max.	Min.		Max.
I _{IN}	Control input current	6.0	V _{IN} = V _{CC} or GND			± 0.1		± 0.1		± 1	μA
I _{CC}	Quiescent supply current	6.0	V _{IN} = V _{CC} or GND V _{IN(analog)} = GND			2		20		40	μA

Table 7. AC electrical characteristics (C_L = 50 pF, input t_r = t_f = 6 ns)

Symbol	Parameter	Test condition		Value						Unit	
		V _{CC} (V)	Test circuit 1	T _A = 25 °C			Up to 85 °C		Up to 125 °C		
				Min.	Typ.	Max.	Min.	Max.	Min.		Max.
t _{PHL} , t _{PLH}	Propagation delay time, analog input to analog output	2.0			19.5	25		29		32	ns
		3.0			12	15.5		17.5		19.5	
		3.3			11	14.5		16.5		18.5	
		4.5			8.6	11.5		12.5		13.5	
		6.0			8	10		11		12	
t _{PHL} , t _{PLH}	Propagation delay time channel-select to analog output	2.0			23	30		35		40	ns
		3.0			13.5	17.5		20		23	
		3.3			12.5	16.5		19		22	
		4.5			10	13		15		17	
		6.0			9.5	12.5		14.5		16.5	
t _{PHZ} , t _{PZH} t _{PLZ} , t _{PZL}	Enable disable time, enable or channel-select to analog output	2.0				95		105		115	ns
		3.0				90		100		110	
		3.3				85		95		105	
		4.5				80		90		100	
		6.0				78		80		80	
C _{IN}	Input capacitance (digital pins)				3.5	10		10		10	pF
C _{IN}	Input capacitance (switches off, any single analog pins)				6.7	15		15		15	pF

Table 7. AC electrical characteristics ($C_L = 50 \text{ pF}$, input $t_r = t_f = 6 \text{ ns}$) (continued)

Symbol	Parameter	Test condition		Value						Unit	
		V_{CC} (V)	Test circuit 1	$T_A = 25 \text{ }^\circ\text{C}$			Up to $85 \text{ }^\circ\text{C}$		Up to $125 \text{ }^\circ\text{C}$		
				Min.	Typ.	Max.	Min.	Max.	Min.		Max.
C_{IN}	Input capacitance (switches off, any common analog pins)				22	40		40		40	pF
C_{PD}	Power dissipation capacitance ⁽¹⁾	3.3			24						pF
		5.0			28						

1. C_{PD} is defined as the value of the IC's internal equivalent capacitance which is calculated from the operating current consumption without load (refer to Figure 5). The average operating current can be obtained by the following equation:
 $I_{CC(opr)} = C_{PD} \times V_{CC} \times f_{IN} + I_{CC}/8$.

Table 8. Injection current coupling specification ($T_A = -55^\circ\text{C}$ to $+125^\circ\text{C}$)

Symbol	Parameter	Test condition		Value		Unit
		V_{CC} (V)	Test circuit 2	Typ. ⁽¹⁾	Max.	
$V_{\Delta OUT}$	Shift of output voltage of enabled analog channel	3.3	$I_{IN} \leq 1 \text{ mA}, R_S \leq 3.9 \text{ k}\Omega$	0.050	1.0	mV
		5.0		0.100	1.0	
		3.3	$I_{IN} \leq 10 \text{ mA}, R_S \leq 3.9 \text{ k}\Omega$	0.345	5.0	
		5.0		0.067	5.0	
		3.3	$I_{IN} \leq 1 \text{ mA}, R_S \leq 20 \text{ k}\Omega$	0.050	2.0	
		5.0		0.110	2.0	
		3.3	$I_{IN} \leq 10 \text{ mA}, R_S \leq 20 \text{ k}\Omega$	0.050	20	
		5.0		0.024	20	

1. Typical values are measured at $T_A = 25^\circ\text{C}$. They are calculated as the difference from V_{OUT} without injection current and V_{OUT} with injection current. I_{IN} = total current injected into any other disabled channels, one at time.

Figure 5. Test circuit 1

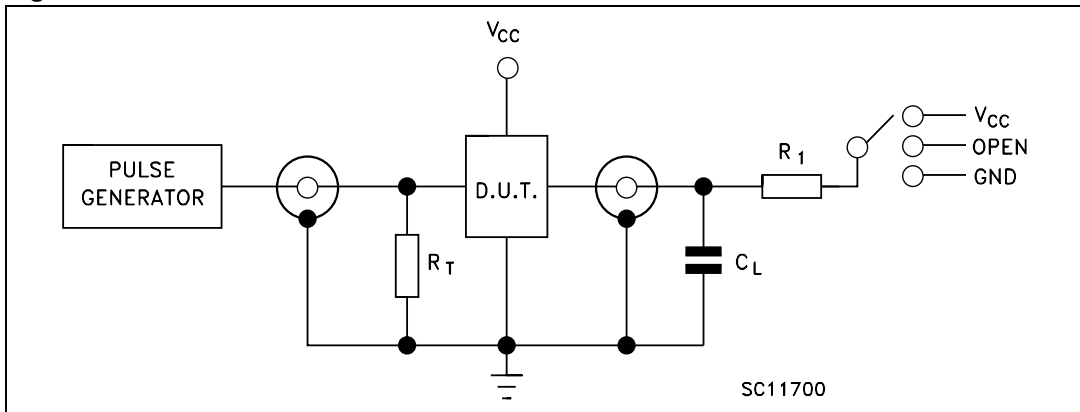

Table 9. Test circuit 1 - switch configuration table

Test	Switch
t_{PLH} , t_{PHL}	Open
t_{PZL} , t_{PLZ}	V_{CC}
t_{PZH} , t_{PHZ}	GND

Note: $C_L = 50 \text{ pF}$ or equivalent (includes jig and probe capacitance).
 $R_L = R_1 = 10 \text{ k}\Omega$ or equivalent.
 $R_T = Z_{OUT}$ of pulse generator (typically 50Ω).

Figure 6. Test circuit 2

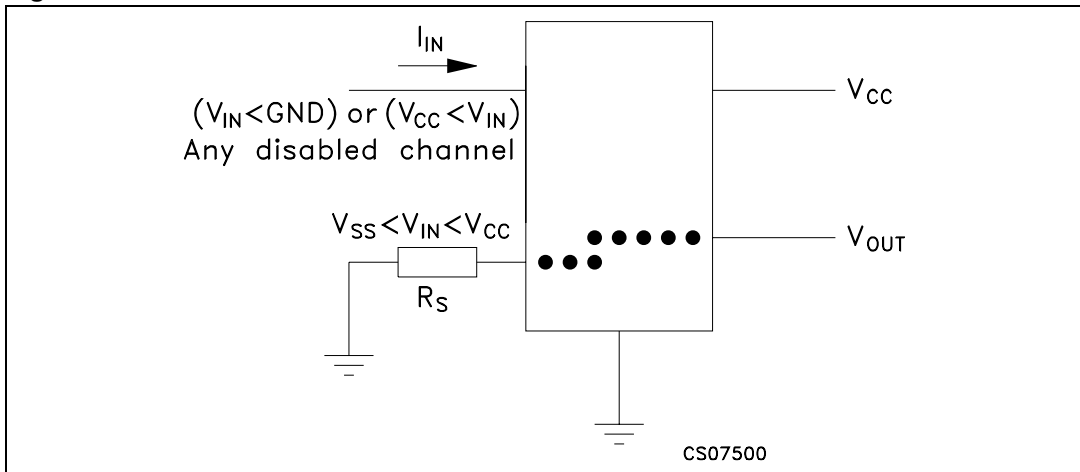

Figure 7. Enable and Disable time

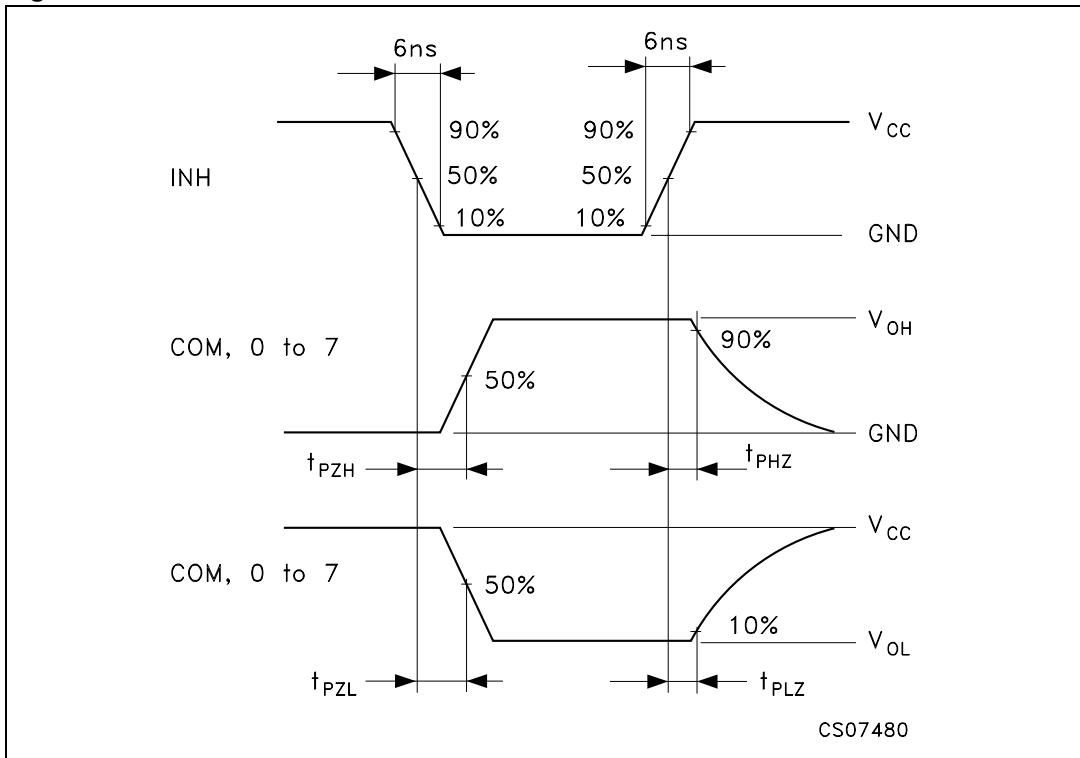

Figure 8. Selection path to output propagation delays

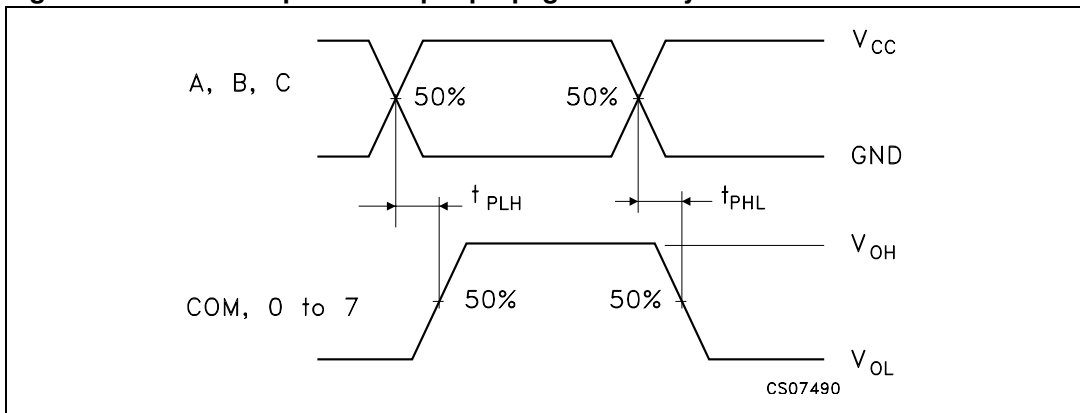

Figure 9. Input (COM, 0 to 7 in) to output (0 to 7 out, COM) propagation delays

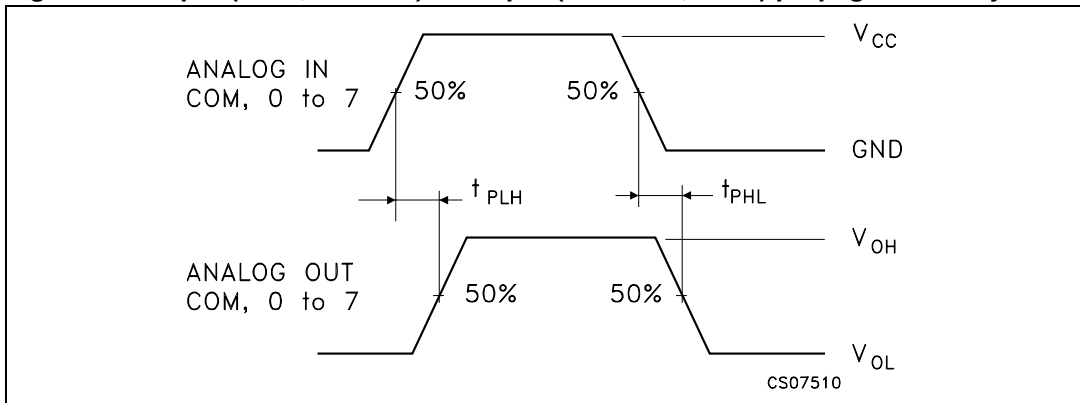

Figure 10. Channel resistance R_{ON}

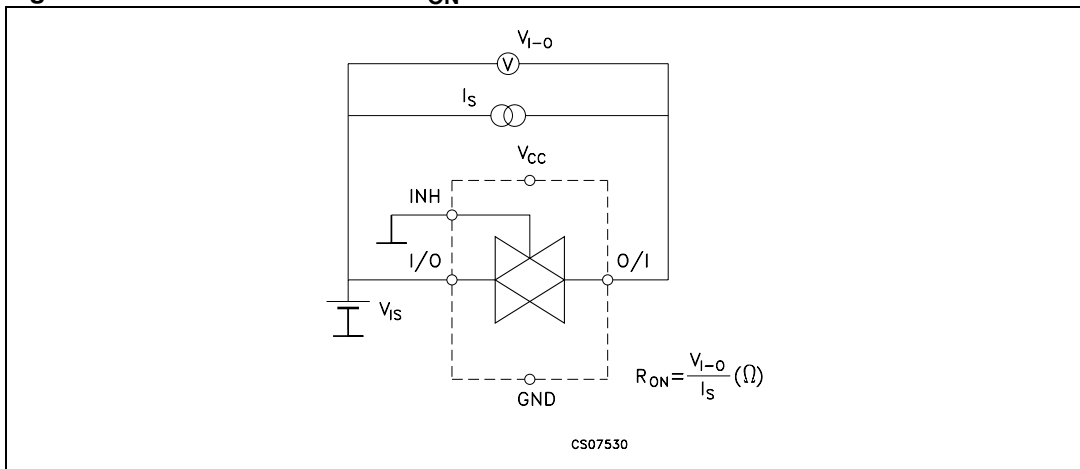
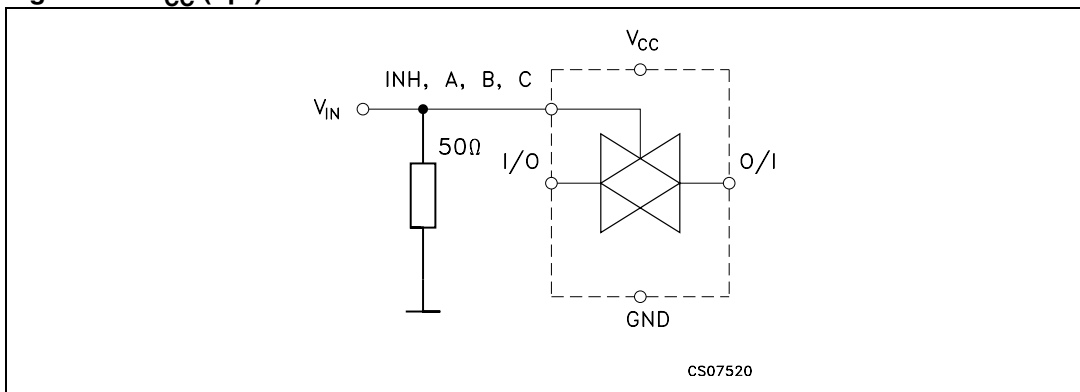

Figure 11. $I_{CC} (opr)$



3 Package information

In order to meet environmental requirements, ST offers these devices in different grades of ECOPACK[®] packages, depending on their level of environmental compliance. ECOPACK[®] specifications, grade definitions and product status are available at: www.st.com. ECOPACK[®] is an ST trademark.

3.1 SO-16 package information

Figure 12. SO-16 mechanical drawing

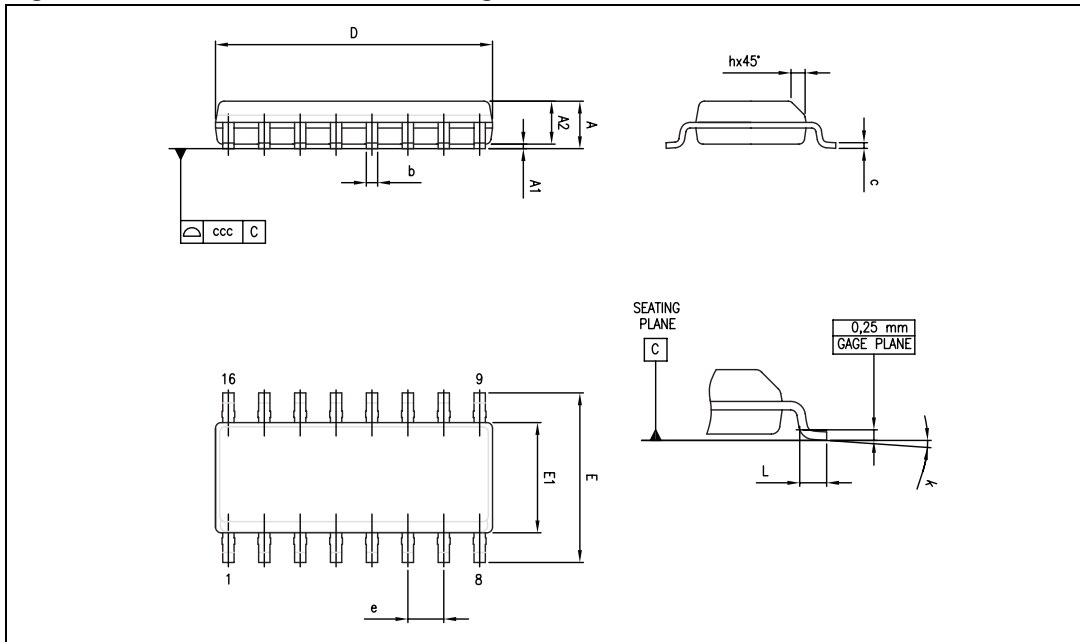

Table 10. SO-16 mechanical data

Ref.	Dimensions					
	Millimeters			Inches		
	Min.	Typ.	Max.	Min.	Typ.	Max.
A			1.75			0.069
A1	0.10		0.25	0.004		0.010
A2	1.25			0.049		
b	0.31		0.51	0.012		0.020
c	0.17		0.25	0.007		0.010
D	9.80	9.90	10.00	0.386	0.390	0.394
E	5.80	6.00	6.20	0.228	0.236	0.244
E1	3.80	3.90	4.00	0.150	0.154	0.157
e		1.27			0.050	
h	0.25		0.50	0.010		0.020
L	0.40		1.27	0.016		0.050
k	0		8			
ccc			0.10			0.004

3.2 TSSOP16 package information

Figure 13. TSSOP16 mechanical drawing

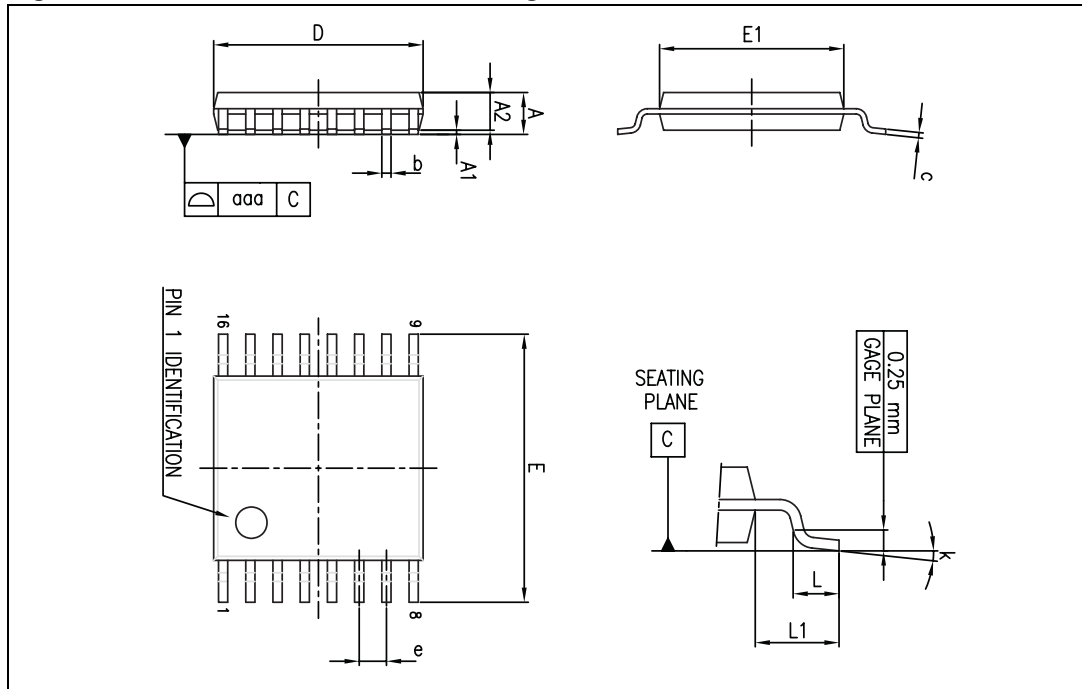

Table 11. TSSOP16 mechanical data

Ref.	Dimensions					
	Millimeters			Inches		
	Min.	Typ.	Max.	Min.	Typ.	Max.
A			1.20			0.047
A1	0.05		0.15	0.002		0.006
A2	0.80	1.00	1.05	0.031	0.039	0.041
b	0.19		0.30	0.007		0.012
c	0.09		0.20	0.004		0.008
D	4.90	5.00	5.10	0.193	0.197	0.201
E	6.20	6.40	6.60	0.244	0.252	0.260
E1	4.30	4.40	4.50	0.169	0.173	0.177
e		0.65			0.0256	
k	0°		8°	0°		8°
L	0.45	0.60	0.75	0.018	0.024	0.030
L1		1.00			0.039	
aaa			0.10			0.004

4 Ordering information

Table 12. Order codes

Order code	Temperature range	Package	Packing	Marking
M74HC4851YRM13TR ⁽¹⁾	-40/+125 °C	SO-16 (automotive grade)	Tape and reel	74HC4851Y
M74HC4851RM13TR	-55/+125 °C	SO-16		74HC4851
M74HC4851YTTR ⁽¹⁾	-40/+125 °C	TSSOP16 (automotive grade)		HC4851Y
M74HC4851TTR	-55/+125 °C	TSSOP16		HC4851

1. Qualification and characterization (according to AEC Q100 and Q003 or equivalent) and advanced screening (according to AEC Q001 and Q002 or equivalent) are ongoing.

5 Revision history

Table 13. Document revision history

Date	Revision	Changes
05-Apr-2012	4	<ul style="list-style-type: none">– Document reformatted.– Added ESD charged device model feature on cover page.– Added ESD values to Table 4: Absolute maximum ratings.– Modified Chapter 3: Package information.– Modified Chapter 4: Ordering information.
11-May-2012	5	<ul style="list-style-type: none">– Added automotive-grade part number M74HC4851YRM13TR to Table 12.: Order codes.– Added Table 1.: Device summary and Modified Description text on coverpage.
15-Jun-2012	6	<ul style="list-style-type: none">– Updated Table 1: Device summary and Table 12: Order codes.– Corrected ON resistance values in Features on page 1– Updated T_{op} in Table 5: Recommended operating conditions– Added footnote 1 to Table 1: Device summary

Please Read Carefully:

Information in this document is provided solely in connection with ST products. STMicroelectronics NV and its subsidiaries ("ST") reserve the right to make changes, corrections, modifications or improvements, to this document, and the products and services described herein at any time, without notice.

All ST products are sold pursuant to ST's terms and conditions of sale.

Purchasers are solely responsible for the choice, selection and use of the ST products and services described herein, and ST assumes no liability whatsoever relating to the choice, selection or use of the ST products and services described herein.

No license, express or implied, by estoppel or otherwise, to any intellectual property rights is granted under this document. If any part of this document refers to any third party products or services it shall not be deemed a license grant by ST for the use of such third party products or services, or any intellectual property contained therein or considered as a warranty covering the use in any manner whatsoever of such third party products or services or any intellectual property contained therein.

UNLESS OTHERWISE SET FORTH IN ST'S TERMS AND CONDITIONS OF SALE ST DISCLAIMS ANY EXPRESS OR IMPLIED WARRANTY WITH RESPECT TO THE USE AND/OR SALE OF ST PRODUCTS INCLUDING WITHOUT LIMITATION IMPLIED WARRANTIES OF MERCHANTABILITY, FITNESS FOR A PARTICULAR PURPOSE (AND THEIR EQUIVALENTS UNDER THE LAWS OF ANY JURISDICTION), OR INFRINGEMENT OF ANY PATENT, COPYRIGHT OR OTHER INTELLECTUAL PROPERTY RIGHT.

UNLESS EXPRESSLY APPROVED IN WRITING BY TWO AUTHORIZED ST REPRESENTATIVES, ST PRODUCTS ARE NOT RECOMMENDED, AUTHORIZED OR WARRANTED FOR USE IN MILITARY, AIR CRAFT, SPACE, LIFE SAVING, OR LIFE SUSTAINING APPLICATIONS, NOR IN PRODUCTS OR SYSTEMS WHERE FAILURE OR MALFUNCTION MAY RESULT IN PERSONAL INJURY, DEATH, OR SEVERE PROPERTY OR ENVIRONMENTAL DAMAGE. ST PRODUCTS WHICH ARE NOT SPECIFIED AS "AUTOMOTIVE GRADE" MAY ONLY BE USED IN AUTOMOTIVE APPLICATIONS AT USER'S OWN RISK.

Resale of ST products with provisions different from the statements and/or technical features set forth in this document shall immediately void any warranty granted by ST for the ST product or service described herein and shall not create or extend in any manner whatsoever, any liability of ST.

ST and the ST logo are trademarks or registered trademarks of ST in various countries.

Information in this document supersedes and replaces all information previously supplied.

The ST logo is a registered trademark of STMicroelectronics. All other names are the property of their respective owners.

© 2012 STMicroelectronics - All rights reserved

STMicroelectronics group of companies

Australia - Belgium - Brazil - Canada - China - Czech Republic - Finland - France - Germany - Hong Kong - India - Israel - Italy - Japan - Malaysia - Malta - Morocco - Philippines - Singapore - Spain - Sweden - Switzerland - United Kingdom - United States of America

www.st.com

