

SINGLE BILATERAL SWITCH

- HIGH SPEED: $t_{PD} = 4ns$ (TYP.) at $V_{CC} = 4.5V$
- LOW POWER DISSIPATION:
 $I_{CC} = 1\mu A$ (MAX.) at $T_A=25^\circ C$
- HIGH NOISE IMMUNITY:
 $V_{NIH} = V_{NIL} = 28\% V_{CC}$ (MIN.)
- LOW "ON" RESISTANCE:
 $R_{ON} = 50\Omega$ (TYP.) AT $V_{CC} = 9V$ $I_{I/O} = 100\mu A$
- SINE WAVE DISTORTION:
0.042% AT $V_{CC} = 4V$ $f = 1KHz$
- WIDE OPERATING RANGE:
 V_{CC} (OPR) = 2V TO 12V

DESCRIPTION

The 74H1G66 is a CMOS SINGLE BILATERAL SWITCH fabricated in silicon gate C²MOS technology. It achieves high speed performance combined with true CMOS low power consumption.

The C input is provided to control the switch and it's compatible with standard CMOS output; the switch is ON (port I/O is connected to Port O/I) when the C input is held high and OFF (high

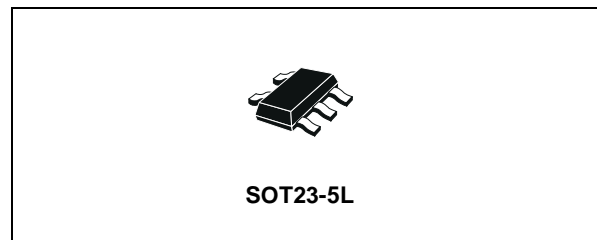

ORDER CODES

PACKAGE	T & R
SOT23-5L	74H1G66STR

impedance state exists between the two ports) when C is held low.

All inputs and output are equipped with protection circuits against static discharge, giving them ESD immunity and transient excess voltage.

PIN CONNECTION AND IEC LOGIC SYMBOLS

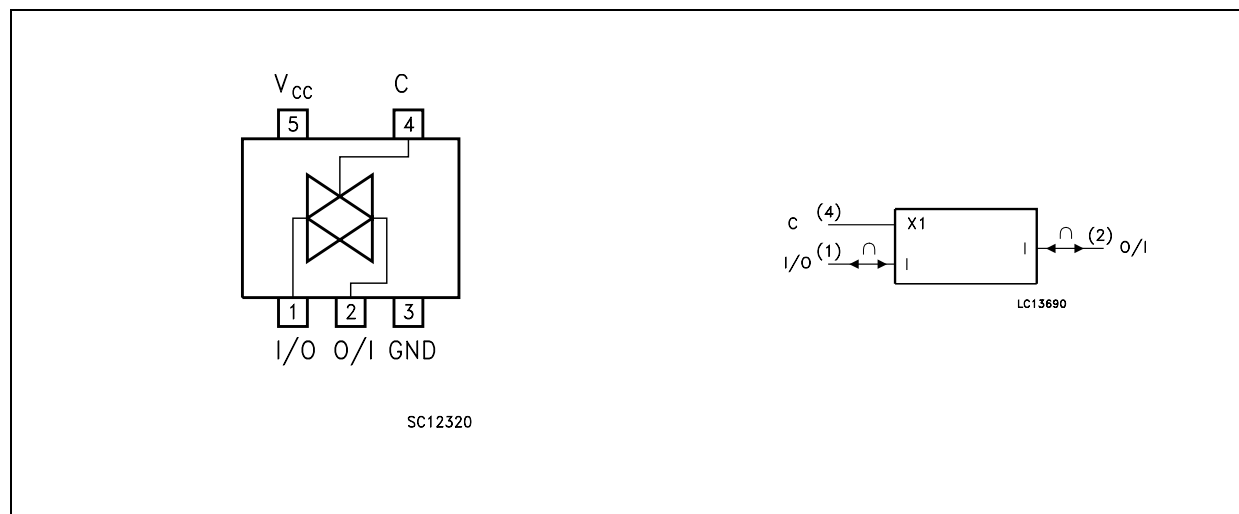

INPUT EQUIVALENT CIRCUIT

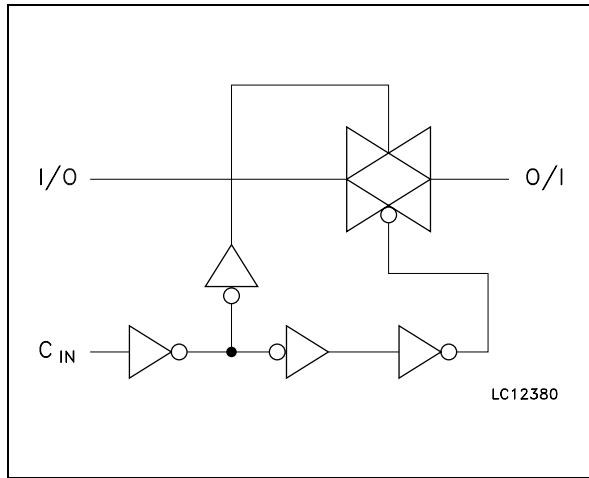

PIN DESCRIPTION

PIN No	SYMBOL	NAME AND FUNCTION
1	I/O	Independent Input/Output
2	O/I	Independent Output/Input
3	GND	Ground (0V)
4	C	Enable Input (Active HIGH)
5	V _{CC}	Positive Supply Voltage

TRUTH TABLE

C	SWITCH FUNCTION
H	ON
L	OFF *

* High Impedance State

ABSOLUTE MAXIMUM RATINGS

Symbol	Parameter	Value	Unit
V _{CC}	Supply Voltage	-0.5 to +13.0	V
V _{I/O}	DC Input/Output Voltage	-0.5 to V _{CC} + 0.5	V
V _{IC}	DC Control Input Voltage	-0.5 to V _{CC} + 0.5	V
I _{I/O}	DC Input/Output Diode Current	± 20	mA
I _{IK}	DC Control Input Diode Current	± 20	mA
I _O	DC Output Source Sink Current per Output Pin	± 25	mA
I _{CC} or I _{GND}	DC V _{CC} or Ground Current	± 50	mA
P _D	Power Dissipation	500 (*)	mW
T _{stg}	Storage Temperature	-65 to +150	°C
T _L	Lead Temperature (10 sec)	300	°C

Absolute Maximum Ratings are those values beyond which damage to the device may occur. Functional operation under these conditions is not implied

(*) 500mW at 65 °C; derate to 300mW by 10mW/°C from 65°C to 85°C

RECOMMENDED OPERATING CONDITIONS

Symbol	Parameter	Value	Unit	
V _{CC}	Supply Voltage	2 to 12	V	
V _I	Control Input Voltage	0 to V _{CC}	V	
V _{I/O}	Input/Output Voltage	0 to V _{CC}	V	
T _{op}	Operating Temperature	-55 to 125	°C	
t _r , t _f	Input Rise and Fall Time on control pin	V _{CC} = 2.0V	0 to 1000	ns
		V _{CC} = 4.5V	0 to 500	ns
		V _{CC} = 6.0V	0 to 400	ns
		V _{CC} = 10.0V	0 to 250	ns

DC SPECIFICATIONS

Symbol	Parameter	Test Condition		Value						Unit	
		V _{CC} (V)		T _A = 25°C			-40 to 85°C		-55 to 125°C		
				Min.	Typ.	Max.	Min.	Max.	Min.		Max.
V _{IH}	High Level Input Voltage	2.0		1.5			1.5		1.5		V
		4.5		3.15			3.15		3.15		
		9.0		6.3			6.3		6.3		
		12.0		8.4			8.4		8.4		
V _{IL}	Low Level Input Voltage	2.0				0.5		0.5		0.5	V
		4.5				1.35		1.35		1.35	
		9.0				2.7		2.7		2.7	
		12.0				3.6		3.6		3.6	
R _{ON}	ON Resistance	4.5	V _{IC} = V _{IH} V _{I/O} = V _{CC} to GND I _{I/O} ≤ 1mA		96	170		200		250	Ω
		9.0			55	85		100		150	
		12.0			45	80		90		120	
R _{ON}	ON Resistance	4.5	V _{IC} = V _{IH} V _{I/O} = V _{CC} or GND I _{I/O} ≤ 1mA		70	100		130		160	Ω
		9.0			50	75		95		115	
		12.0			45	70		90		110	
I _{OFF}	Input/Output Leakage Current (SWITCH OFF)	12.0	V _{OS} = V _{CC} to GND V _{IS} = V _{CC} to GND V _{IC} = V _{IL}			±0.1		± 1		± 2	μA
I _{Iz}	Switch Input Leakage Current (SWITCH ON, OUTPUT OPEN)	12.0	V _{OS} = V _{CC} to GND V _{IC} = V _{IH}			±0.1		± 1		± 2	μA
I _{IN}	Control Input Leakage Current	6.0	V _{IC} = 5.5V or GND			± 0.1		± 1.0		± 1.0	μA
I _{CC}	Quiescent Supply Current	6.0	V _I = V _{CC} or GND			1		10		20	μA
		9.0				4		40		80	
		12.0				8		80		160	

AC ELECTRICAL CHARACTERISTICS ($C_L = 50\text{pF}$, Input $t_r = t_f = 6\text{ns}$)

Symbol	Parameter	Test Condition		Value						Unit	
		V_{CC} (V)		$T_A = 25^\circ\text{C}$			-40 to 85°C		-55 to 125°C		
				Min.	Typ.	Max.	Min.	Max.	Min.		Max.
$\Phi_{I/O}$	Phase Difference Between Input and Output	2.0			10	50		65		75	ns
		4.5			4	10		15		18	
		9.0			3	8		13		16	
		12.0			3	7		10		12	
t_{PLZ} t_{PHZ}	Output Disable Time	2.0	$R_L = 500\ \Omega$		18	100		125		150	ns
		4.5			8	20		25		30	
		9.0			6	12		22		27	
		12.0			6	12		18		25	
t_{PZL} t_{PZH}	Output Enable Time	2.0	$R_L = 1\ \text{K}\Omega$		20	115		145		175	ns
		4.5			10	23		29		35	
		9.0			8	20		25		30	
		12.0			8	18		22		27	
	Maximum Control Input Frequency	2.0	$R_L = 1\ \text{K}\Omega$ $C_L = 15\text{pF}$ $V_O = 1/2V_{CC}$		30						MHz
		4.5			30						
		9.0			30						
		12.0			30						

CAPACITIVE CHARACTERISTICS

Symbol	Parameter	Test Condition		Value						Unit	
				$T_A = 25^\circ\text{C}$			-40 to 85°C		-55 to 125°C		
				Min.	Typ.	Max.	Min.	Max.	Min.		Max.
C_{IN}	Input Capacitance				5	10		10		10	pF
$C_{I/O}$	Switch Terminal Capacitance				10						pF
C_{IOS}	Feed through Capacitance				0.5						pF
C_{PD}	Power Dissipation Capacitance (note 1)				15						pF

1) C_{PD} is defined as the value of the IC's internal equivalent capacitance which is calculated from the operating current consumption without load. (Refer to Test Circuit). Average operating current can be obtained by the following equation. $I_{CC(oper)} = C_{PD} \times V_{CC} \times f_{IN} + I_{CC}$

ANALOG SWITCH CHARACTERISTICS (GND = 0V; $T_A = 25^\circ\text{C}$)

Symbol	Parameter	Test Condition		Value	Unit	
		V_{CC} (V)	V_{IN} (V_{p-p})	Typ.		
	Sine Wave Distortion (THD)	4.5	4	$f_{IN} = 1 \text{ KHz}$, $R_L = 10 \text{ K}\Omega$, $C_L = 50 \text{ pF}$	0.04	%
		9.0	8		0.04	
f_{MAX}	Frequency Response (Switch ON)	4.5	Adjust f_{IN} voltage to obtain 0 dBm at V_{OS} . Increase f_{IN} Frequency until dB meter reads -3dB $R_L = 50\Omega$, $C_L = 10 \text{ pF}$	150	MHz	
		9.0		180		
	Feed through Attenuation (Switch OFF)	4.5	V_{IN} is centered at $V_{CC}/2$ Adjust f_{IN} Voltage to obtained 0dBm at V_{IS} $R_L = 600\Omega$, $C_L = 50 \text{ pF}$, $f_{IN} = 1\text{KHz}$ sine wave	-60	dB	
		9.0		-60		
	Crosstalk (Control Input to Signal Output)	4.5	$R_L = 600\Omega$, $C_L = 50 \text{ pF}$, $f_{IN} = 1\text{KHz}$ square wave $t_r = t_f = 6\text{ns}$	60	mV	
		9.0		60		

SWITCHING CHARACTERISTICS TEST CIRCUIT

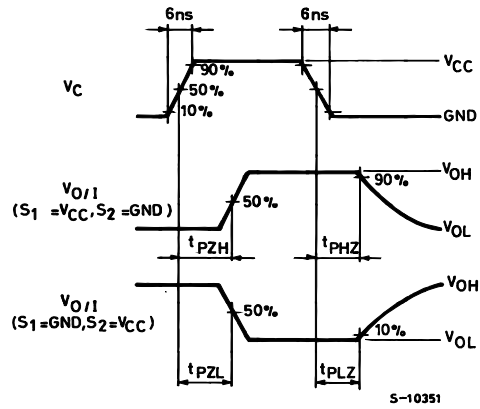
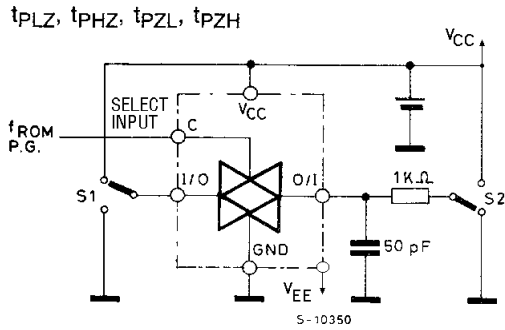

CROSSTALK (control to output)

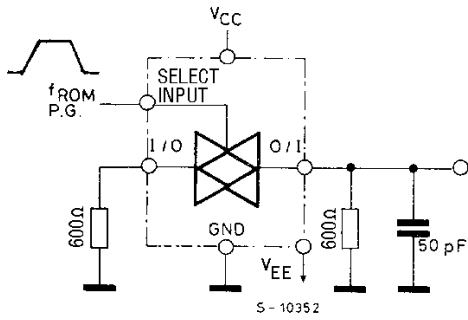

BANDWIDTH AND FEEDTHROUGH ATTENUATION

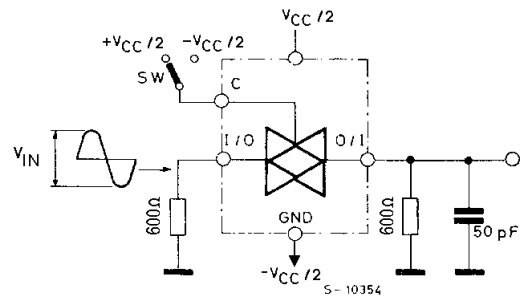

MAXIMUM CONTROL FREQUENCY

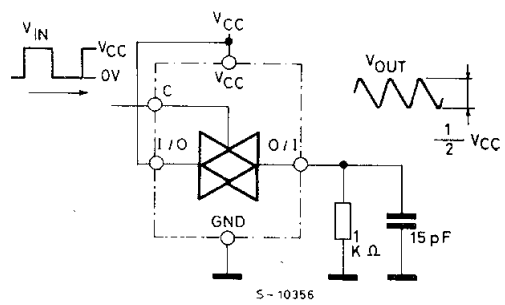
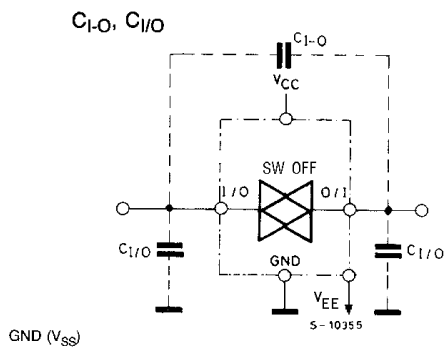

CHANNEL RESISTANCE (R_{ON})

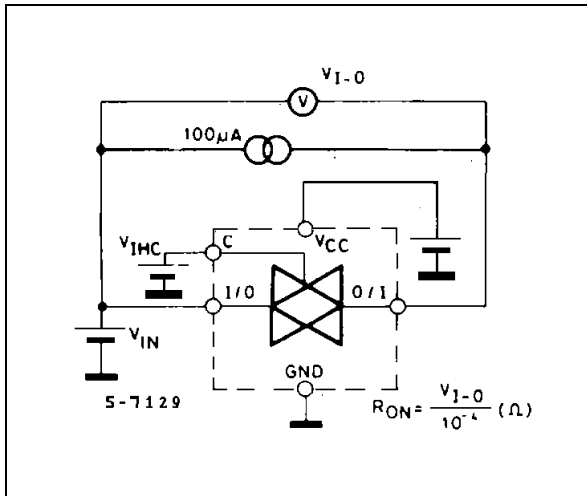

I_{CC} (Opr.)

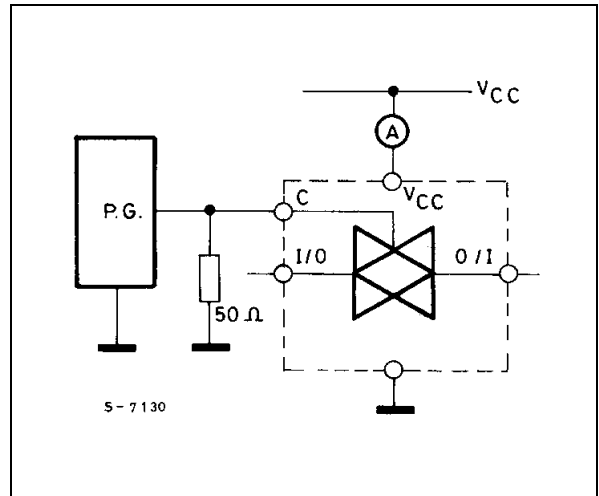

SOT23-5L MECHANICAL DATA

DIM.	mm.			mils		
	MIN.	TYP.	MAX.	MIN.	TYP.	MAX.
A	0.90		1.45	35.4		57.1
A1	0.00		0.15	0.0		5.9
A2	0.90		1.30	35.4		51.2
b	0.35		0.50	13.7		19.7
C	0.09		0.20	3.5		7.8
D	2.80		3.00	110.2		118.1
E	2.60		3.00	102.3		118.1
E1	1.50		1.75	59.0		68.8
e		0.95			37.4	
e1		1.9			74.8	
L	0.35		0.55	13.7		21.6

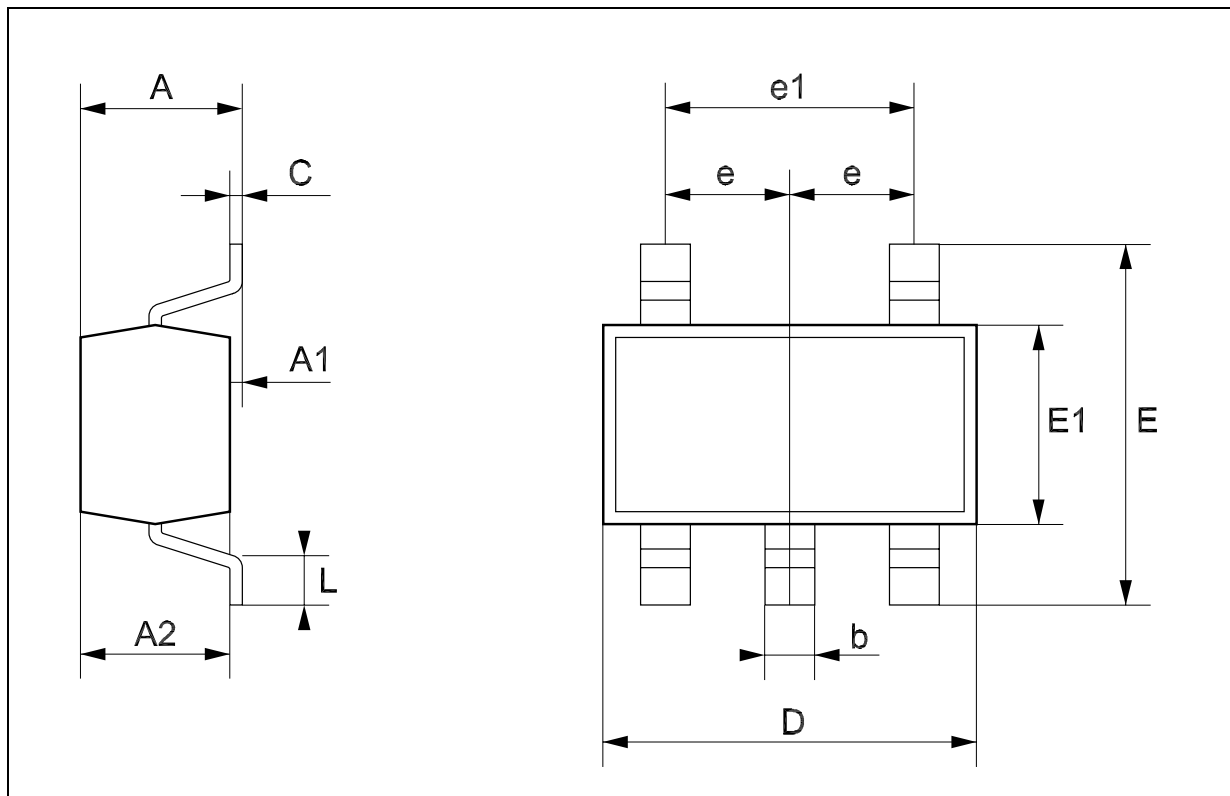

Tape & Reel SOT23-xL MECHANICAL DATA

DIM.	mm.			inch		
	MIN.	TYP	MAX.	MIN.	TYP.	MAX.
A			180			7.086
C	12.8	13.0	13.2	0.504	0.512	0.519
D	20.2			0.795		
N	60			2.362		
T			14.4			0.567
Ao	3.13	3.23	3.33	0.123	0.127	0.131
Bo	3.07	3.17	3.27	0.120	0.124	0.128
Ko	1.27	1.37	1.47	0.050	0.054	0.058
Po	3.9	4.0	4.1	0.153	0.157	0.161
P	3.9	4.0	4.1	0.153	0.157	0.161

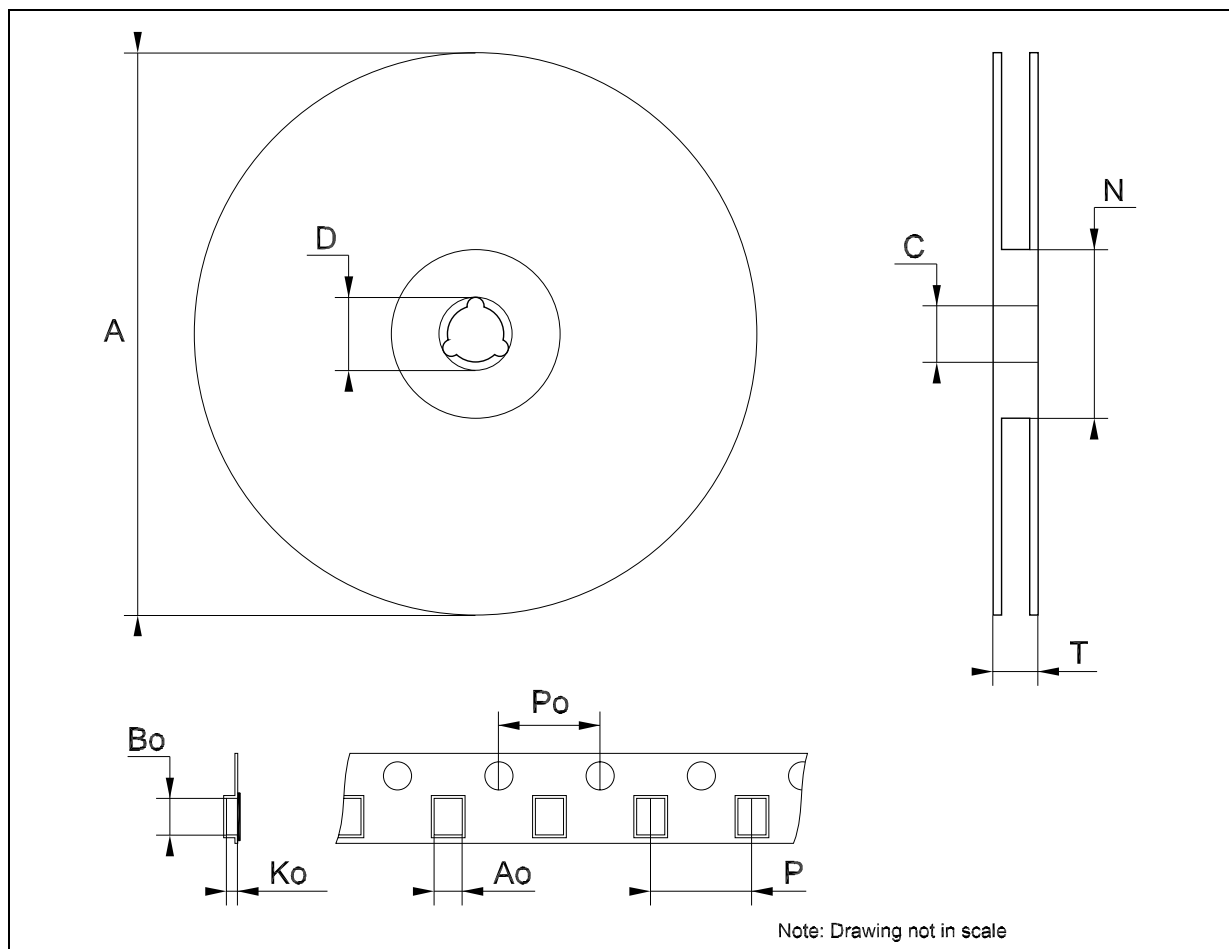

Information furnished is believed to be accurate and reliable. However, STMicroelectronics assumes no responsibility for the consequences of use of such information nor for any infringement of patents or other rights of third parties which may result from its use. No license is granted by implication or otherwise under any patent or patent rights of STMicroelectronics. Specifications mentioned in this publication are subject to change without notice. This publication supersedes and replaces all information previously supplied. STMicroelectronics products are not authorized for use as critical components in life support devices or systems without express written approval of STMicroelectronics.

© The ST logo is a registered trademark of STMicroelectronics

© 2001 STMicroelectronics - Printed in Italy - All Rights Reserved
STMicroelectronics GROUP OF COMPANIES

Australia - Brazil - China - Finland - France - Germany - Hong Kong - India - Italy - Japan - Malaysia - Malta - Morocco
Singapore - Spain - Sweden - Switzerland - United Kingdom

© <http://www.st.com>