



DUAL MONOSTABLE MULTIVIBRATOR

- RETRIGGERABLE/RESETTABLE CAPABILITY
- TRIGGER AND RESET PROPAGATION DELAYS INDEPENDENT OF R_X , C_X
- TRIGGERING FROM LEADING OR TRAILING EDGE
- Q AND \bar{Q} BUFFERED OUTPUT AVAILABLE
- SEPARATE RESETS
- WIDE RANGE OF OUTPUT PULSE WIDTHS
- QUIESCENT CURRENT SPECIFIED UP TO 20V
- 5V, 10V AND 15V PARAMETRIC RATINGS
- SCHMITT TRIGGER INPUT ALLOWS UNLIMITED RISE AND FALL TIMES ON +TR AND -TR INPUTS
- INPUT LEAKAGE CURRENT
 $I_1 = 100\text{nA (MAX) AT } V_{DD} = 18\text{V } T_A = 25^\circ\text{C}$
- 100% TESTED FOR QUIESCENT CURRENT
- MEETS ALL REQUIREMENTS OF JEDEC JESD13B "STANDARD SPECIFICATIONS FOR DESCRIPTION OF B SERIES CMOS DEVICES"

DESCRIPTION

The HCF4538B is a monolithic integrated circuit fabricated in Metal Oxide Semiconductor technology available in DIP and SOP packages. The HCF4538B dual precision monostable multivibrator provides stable retriggerable/resettable one-shot operation for any fixed voltage

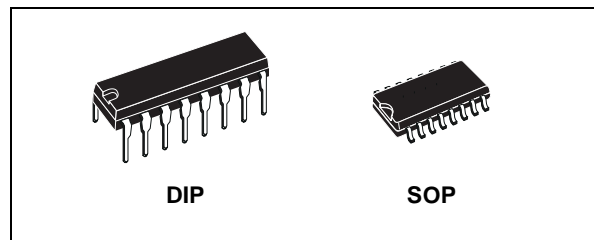

ORDER CODES

PACKAGE	TUBE	T & R
DIP	HCF4538BEY	
SOP	HCF4538BM1	HCF4538M013TR

timing application. An external resistor (R_X) and an external capacitor (C_X) control the timing and accuracy for the circuit. Adjustment of R_X and C_X provides a wide range of output pulse widths from the Q and \bar{Q} terminals. The time delay from trigger input to output transition (trigger propagation delay) and the time delay from reset input to output transition (reset propagation delay) and the time delay from reset input to output transition (reset propagation delay) are independent of R_X and C_X . Precision control of output pulse width is achieved through linear CMOS techniques. Leading edge triggering (+TR) and trailing edge triggering (-TR) inputs are provided for triggering

PIN CONNECTION

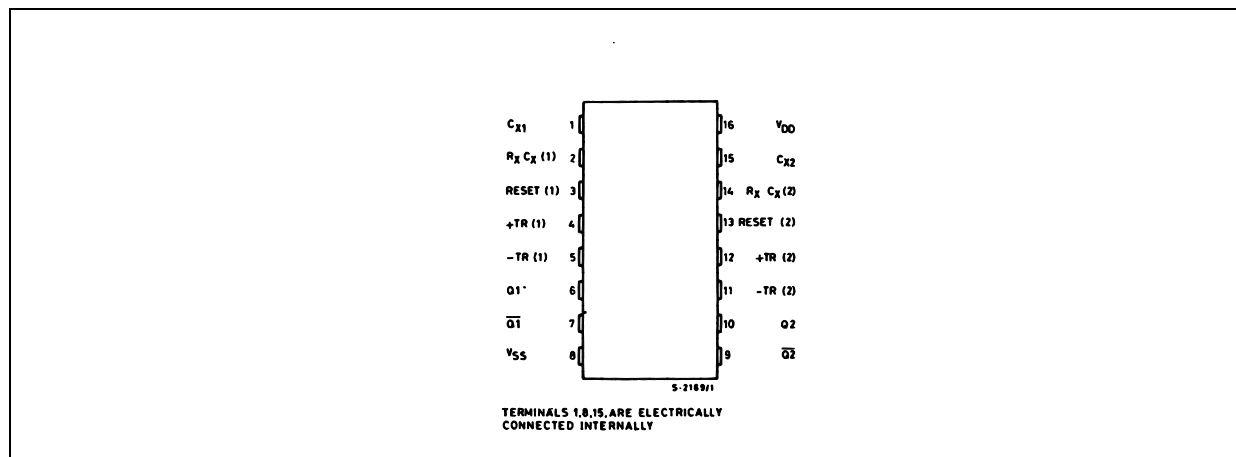

HCF4538B

from either edge of an input pulse. An unused +TR input should be tied to V_{SS} . An unused -TR input should be tied to V_{DD} . A RESET (on low level) is provided for immediate termination of the output pulse or to prevent output pulses when power is turned on. An unused RESET input should be tied to V_{DD} . However, if an entire section of the HCF4538B is not used, its inputs must be tied to either V_{DD} or V_{SS} (see table 1). In normal operation the circuit triggers (extends the output

IINPUT EQUIVALENT CIRCUIT

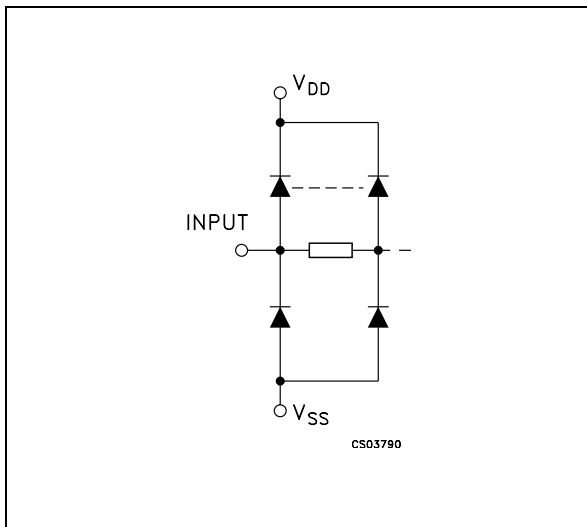

pulse one period) on the application of each new trigger pulse. For operation in the non-retiggerable mode, \bar{Q} is connected to -TR when leading edge triggering (+TR) is used or Q is connected to +TR when trailing edge triggering (-TR) is used. The time period (T) for this multivibrator can be calculated by : $T = R_X C_X$. The min. value of external resistance, R_X , is 4K Ω . The max. and min. values of external capacitance, C_X , are 100 μ F and 5nF, respectively.

PIN DESCRIPTION

PIN No	SYMBOL	NAME AND FUNCTION
4, 12	+TR	Trigger Inputs (Low to High, Edge-Triggered)
5, 11	-TR	Trigger Inputs (High to Low, Edge-Triggered)
3, 13	RESET	Direct Reset Inputs (Active Low)
1, 15	C_X1, C_X2	External Capacitor Connections
2, 14	$R_X C_X1$ $R_X C_X2$	External Resistor/Capacitor Connections
6, 10	Q1, Q2	Pulse Outputs
7, 9	$\bar{Q}1, \bar{Q}2$	Complementary Pulse Outputs
8	V_{SS}	Negative Supply Voltage
16	V_{DD}	Positive Supply Voltage

Terminals 1, 8, 15 are electrically connected internally

FUNCTIONAL DIAGRAM

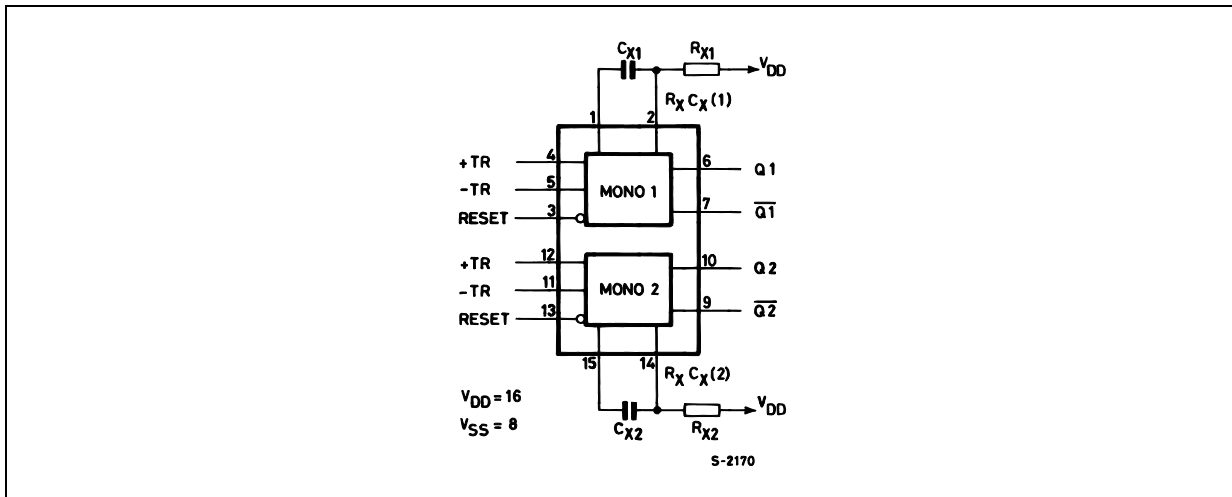

TABLE 1 : Functional Terminal Connections

FUNCTION	V _{DD} to Term. N°		V _{SS} to Term. N°		Input Pulse to Term. N°		Other Connections	
	Mono (1)	Mono (2)	Mono (1)	Mono (2)	Mono (1)	Mono (2)	Mono (1)	Mono (2)
Leading Edge Trigger/Retriggerable	3, 5	11, 13			4	12		
Leading Edge Trigger/Non Retriggerable	3	13			4	12	5, 7	11, 9
Trailing Edge Trigger/Retriggerable	3	13	4	12	5	11		
Trailing Edge Trigger/Non Retriggerable	3	13			5	11	4, 6	12, 10

A Retriggerable one-shot multivibrator has an output pulse width which is extended on full time period (T) after application of the last trigger pulse.

A Non-Retriggerable one-shot multivibrator has a time period (T) referenced from the application of the first trigger pulse.

LOGIC DIAGRAM

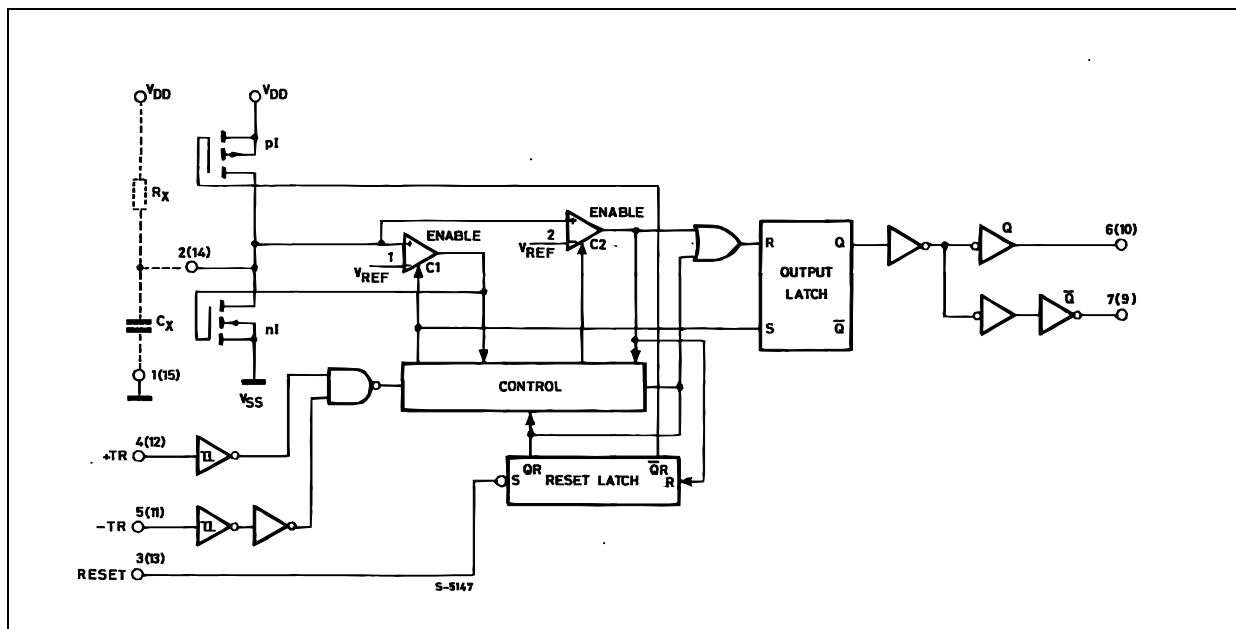

LOGIC DIAGRAM

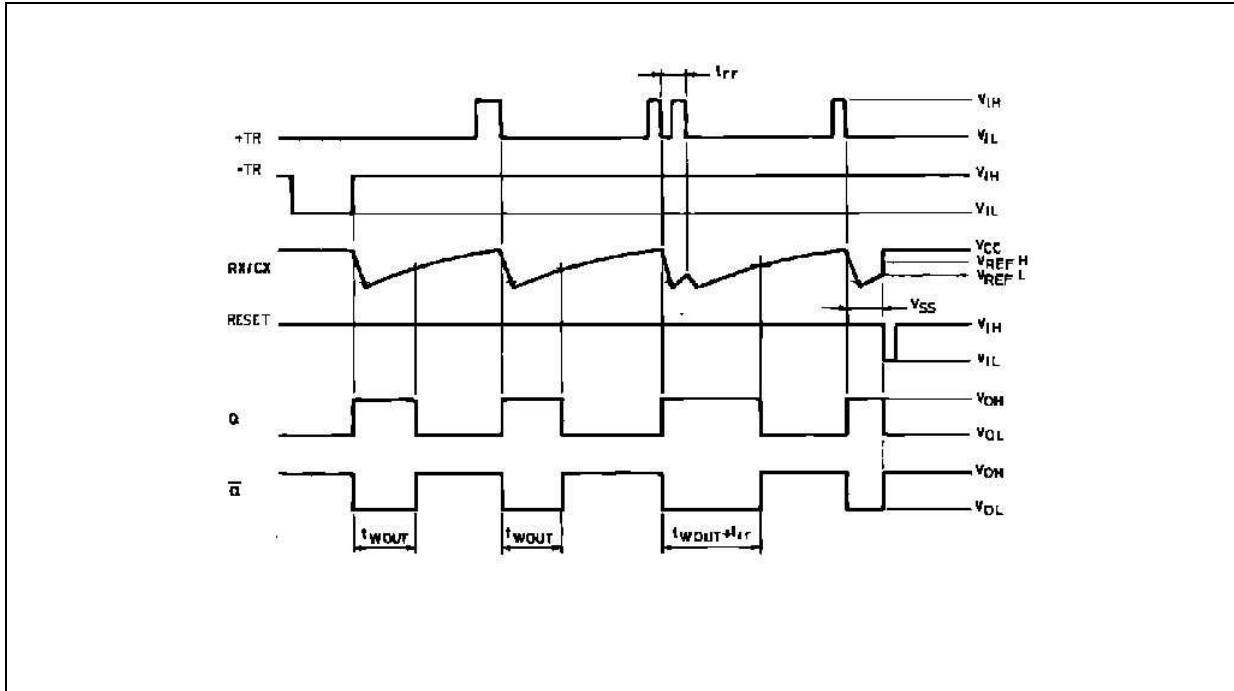

ABSOLUTE MAXIMUM RATINGS

Symbol	Parameter	Value	Unit
V_{DD}	Supply Voltage	-0.5 to +22	V
V_I	DC Input Voltage	-0.5 to $V_{DD} + 0.5$	V
I_I	DC Input Current	± 10	mA
P_D	Power Dissipation per Package	200	mW
	Power Dissipation per Output Transistor	100	mW
T_{op}	Operating Temperature	-55 to +125	$^{\circ}C$
T_{stg}	Storage Temperature	-65 to +150	$^{\circ}C$

Absolute Maximum Ratings are those values beyond which damage to the device may occur. Functional operation under these conditions is not implied.

All voltage values are referred to V_{SS} pin voltage.

RECOMMENDED OPERATING CONDITIONS

Symbol	Parameter	Value	Unit
V_{DD}	Supply Voltage	3 to 20	V
V_I	Input Voltage	0 to V_{DD}	V
T_{op}	Operating Temperature	-55 to 125	$^{\circ}C$

DC SPECIFICATIONS

Symbol	Parameter	Test Condition				Value						Unit	
		V _I (V)	V _O (V)	I _{OL} (μ A)	V _{DD} (V)	T _A = 25°C			-40 to 85°C		-55 to 125°C		
						Min.	Typ.	Max.	Min.	Max.	Min.		Max.
I _L	Quiescent Current	0/5			5		0.04	5		150		150	μ A
		0/10			10		0.04	10		300		300	
		0/15			15		0.04	20		600		600	
		0/20			20		0.08	100		3000		3000	
V _{OH}	High Level Output Voltage	0/5		<1	5	4.95			4.95		4.95		V
		0/10		<1	10	9.95			9.95		9.95		
		0/15		<1	15	14.95			14.95		14.95		
V _{OL}	Low Level Output Voltage	5/0		<1	5		0.05			0.05		0.05	V
		10/0		<1	10		0.05			0.05		0.05	
		15/0		<1	15		0.05			0.05		0.05	
V _{IH}	High Level Input Voltage		0.5/4.5	<1	5	3.5			3.5		3.5		V
			1/9	<1	10	7			7		7		
			1.5/13.5	<1	15	11			11		11		
V _{IL}	Low Level Input Voltage		4.5/0.5	<1	5			1.5		1.5		1.5	V
			9/1	<1	10			3		3		3	
			13.5/1.5	<1	15			4		4		4	
I _{OH}	Output Drive Current	0/5	2.5	<1	5	-1.6	-3.2		-1.3		-1.3		mA
		0/5	4.6	<1	5	-0.51	-1		-0.42		-0.42		
		0/10	9.5	<1	10	-1.3	-2.6		-1.1		-1.1		
		0/15	13.5	<1	15	-3.4	-6.8		-2.8		-2.8		
I _{OL}	Output Sink Current	0/5	0.4	<1	5	-0.51	1		-0.42		-0.42		mA
		0/10	0.5	<1	10	-1.3	2.6		-1.1		-1.1		
		0/15	1.5	<1	15	-3.4	6.8		-2.8		-2.8		
I _I	Input Leakage Current	0/18	Any Input		18		$\pm 10^{-5}$	± 0.1		± 1		± 1	μ A
C _I	Input Capacitance		Any Input				5	7.5					pF

The Noise Margin for both "1" and "0" level is: 1V min. with V_{DD}=5V, 2V min. with V_{DD}=10V, 2.5V min. with V_{DD}=15V

DYNAMIC ELECTRICAL CHARACTERISTICS ($T_{amb} = 25^{\circ}\text{C}$, $C_L = 50\text{pF}$, $R_L = 200\text{K}\Omega$, $t_r = t_f = 20\text{ ns}$)

Symbol	Parameter	Test Condition		Value (*)			Unit
		V_{DD} (V)		Min.	Typ.	Max.	
t_{TLH} t_{THL}	Transition Time	5			100	200	ns
		10			50	100	
		15			40	80	
t_{PLH} t_{PHL}	Propagation Delay Time +TR or -TR to Q or \bar{Q}	5			300	600	ns
		10			150	300	
		15			100	200	
t_{PLH} t_{PHL}	Propagation Delay Time Reset to Q or \bar{Q}	5	$R_L = 1\text{K}\Omega$		250	500	ns
		10			125	250	
		15			95	190	
t_{WH} t_{WL}	Minimum Input Pulse Width +TR, -TR or Reset	5	$R_L = 1\text{K}\Omega$		80	140	ns
		10			40	80	
		15			30	60	
t_{WT}	Output Pulse Width - Q or \bar{Q} ($C_X = 0.005\ \mu\text{F}$, $R_X =$ $10\text{K}\Omega$ ⁽¹⁾)	5		57	60.6	64.5	μs
		10		55	58.9	63.0	
		15		55	59.1	63.5	
t_{WT}	Output Pulse Width - Q or \bar{Q} ($C_X = 0.1\ \mu\text{F}$, $R_X =$ $100\text{K}\Omega$)	5		9.4	9.97	10.5	ms
		10		9.4	9.95	10.6	
		15		9.5	10.0	10.6	
t_{WT}	Output Pulse Width - Q or \bar{Q} ($C_X = 10\ \mu\text{F}$, $R_X =$ $100\text{K}\Omega$)	5		0.95	1.0	1.06	s
		10		0.95	1.0	1.06	
		15		0.96	1.0	1.07	
t_w	Pulse Width Match Between Circuits in Same Package : $(100(T_1 - T_2)/T_1)$ ($C_X = 0.1\ \mu\text{F}$, $R_X = 100\text{K}\Omega$)	5			± 1		%
		10			± 1		
		15			± 1		
t_{rr}	Minimum Retrigger Time	5		0			ns
		10		0			
		15		0			
C_{IN}	Input Capacitance	Any Input			5	7.5	pF

(*) Typical temperature coefficient for all V_{DD} value is 0.3 %/°C.

(1) Minimum R_X value = 4K Ω , minimum C_X value = 5000 pF

TEST CIRCUIT

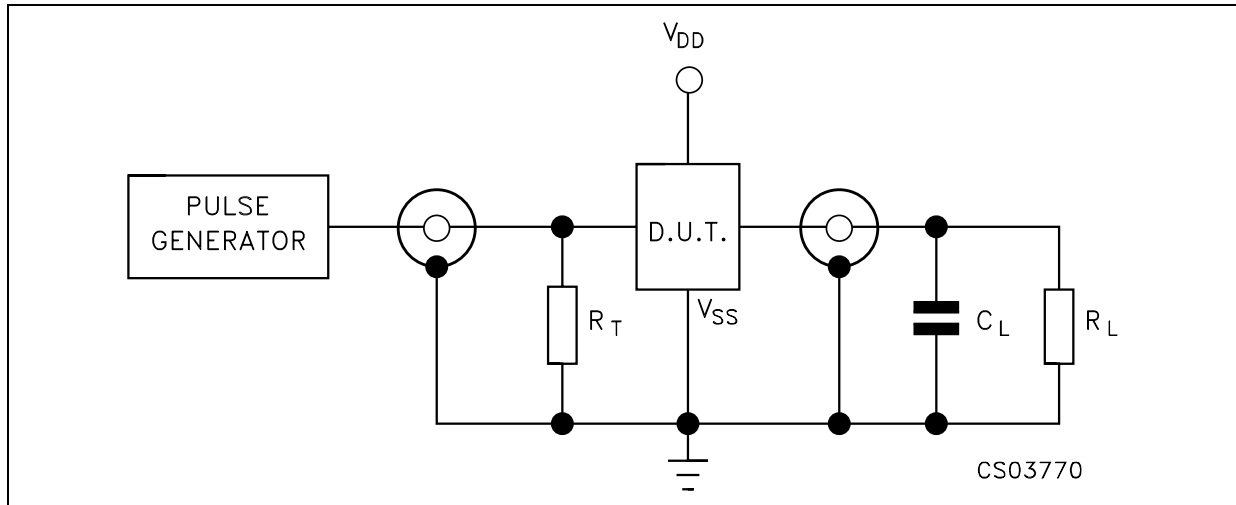

$C_L = 50\text{pF}$ or equivalent (includes jig and probe capacitance)
 $R_L = 200\text{K}\Omega$
 $R_T = Z_{OUT}$ of pulse generator (typically 50Ω)

WAVEFORM : PROPAGATION DELAY TIMES (f=1MHz; 50% duty cycle)

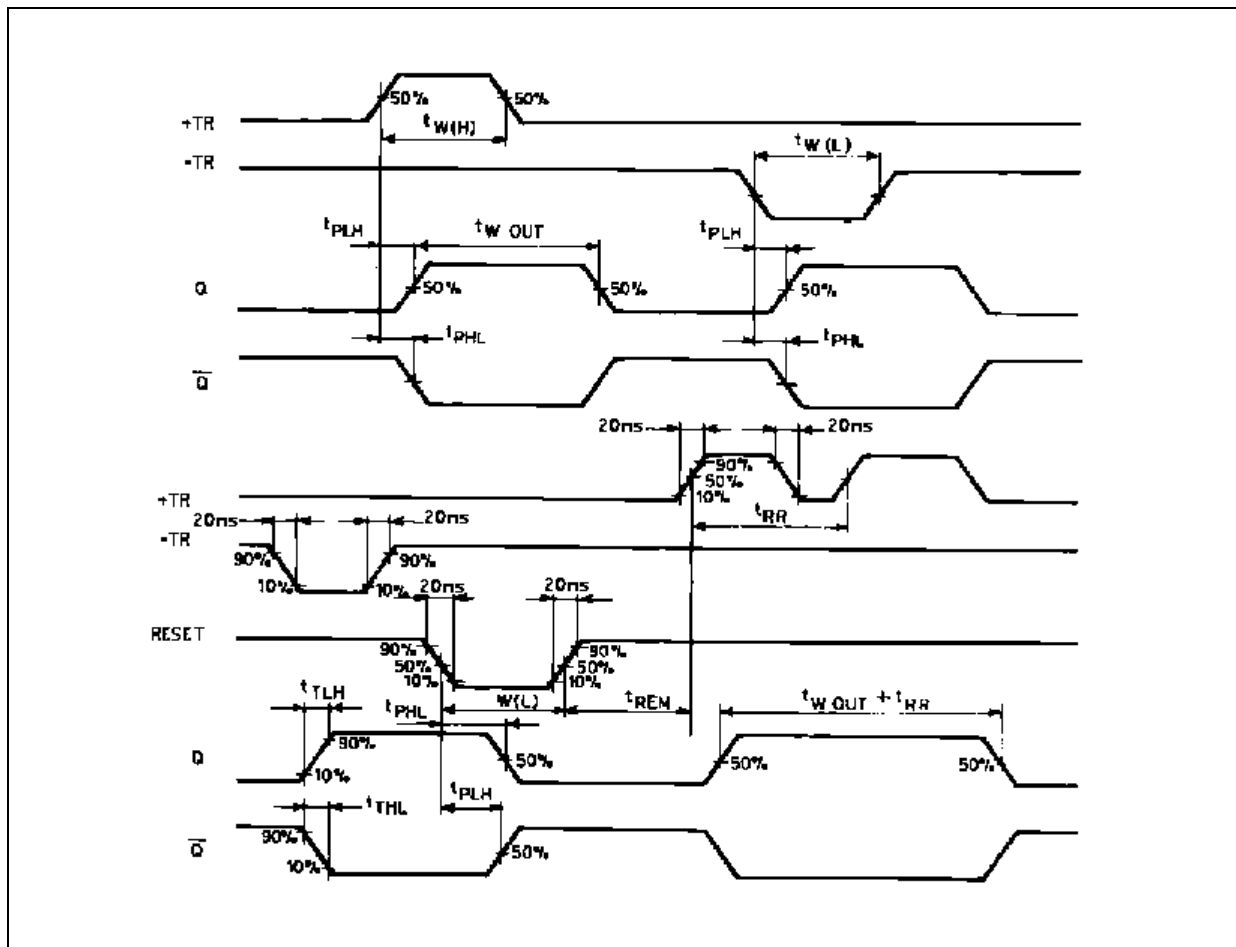

Plastic DIP-16 (0.25) MECHANICAL DATA

DIM.	mm.			inch		
	MIN.	TYP	MAX.	MIN.	TYP.	MAX.
a1	0.51			0.020		
B	0.77		1.65	0.030		0.065
b		0.5			0.020	
b1		0.25			0.010	
D			20			0.787
E		8.5			0.335	
e		2.54			0.100	
e3		17.78			0.700	
F			7.1			0.280
I			5.1			0.201
L		3.3			0.130	
Z			1.27			0.050

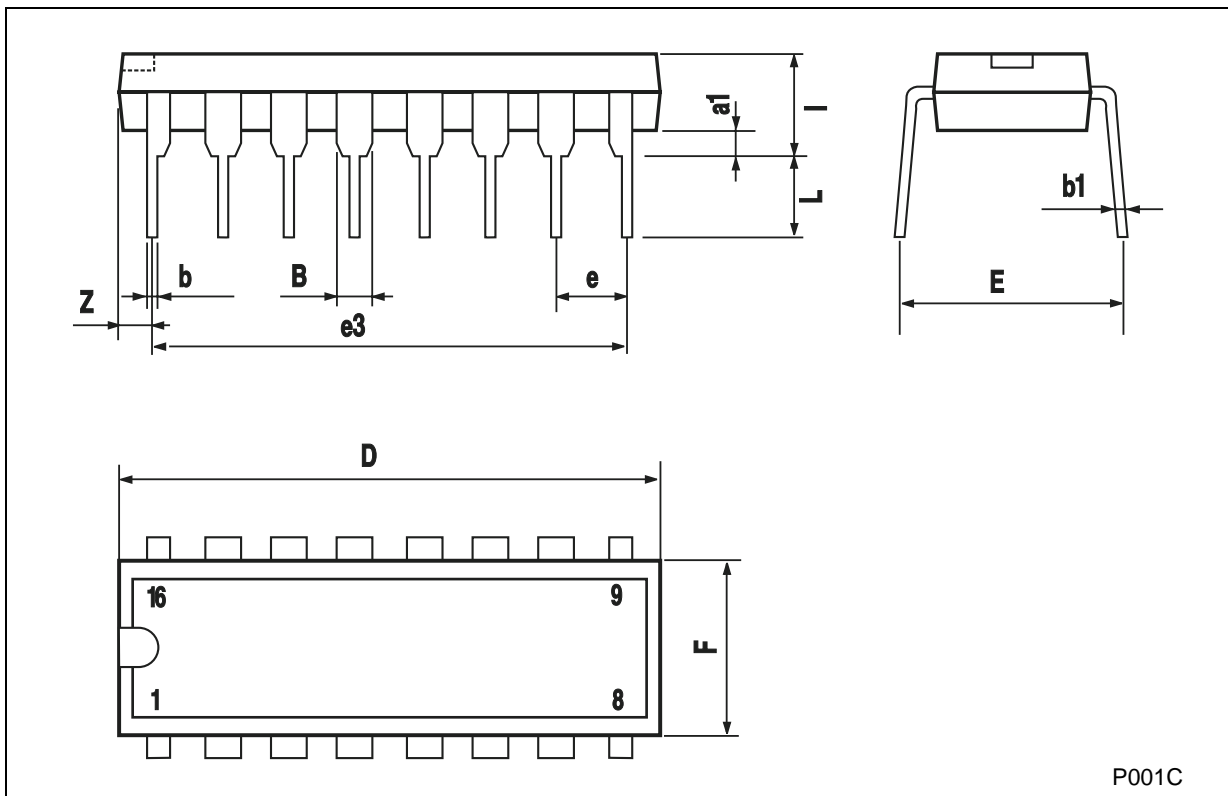

SO-16 MECHANICAL DATA

DIM.	mm.			inch		
	MIN.	TYP.	MAX.	MIN.	TYP.	MAX.
A			1.75			0.068
a1	0.1		0.2	0.003		0.007
a2			1.65			0.064
b	0.35		0.46	0.013		0.018
b1	0.19		0.25	0.007		0.010
C		0.5			0.019	
c1	45° (typ.)					
D	9.8		10	0.385		0.393
E	5.8		6.2	0.228		0.244
e		1.27			0.050	
e3		8.89			0.350	
F	3.8		4.0	0.149		0.157
G	4.6		5.3	0.181		0.208
L	0.5		1.27	0.019		0.050
M			0.62			0.024
S	8° (max.)					

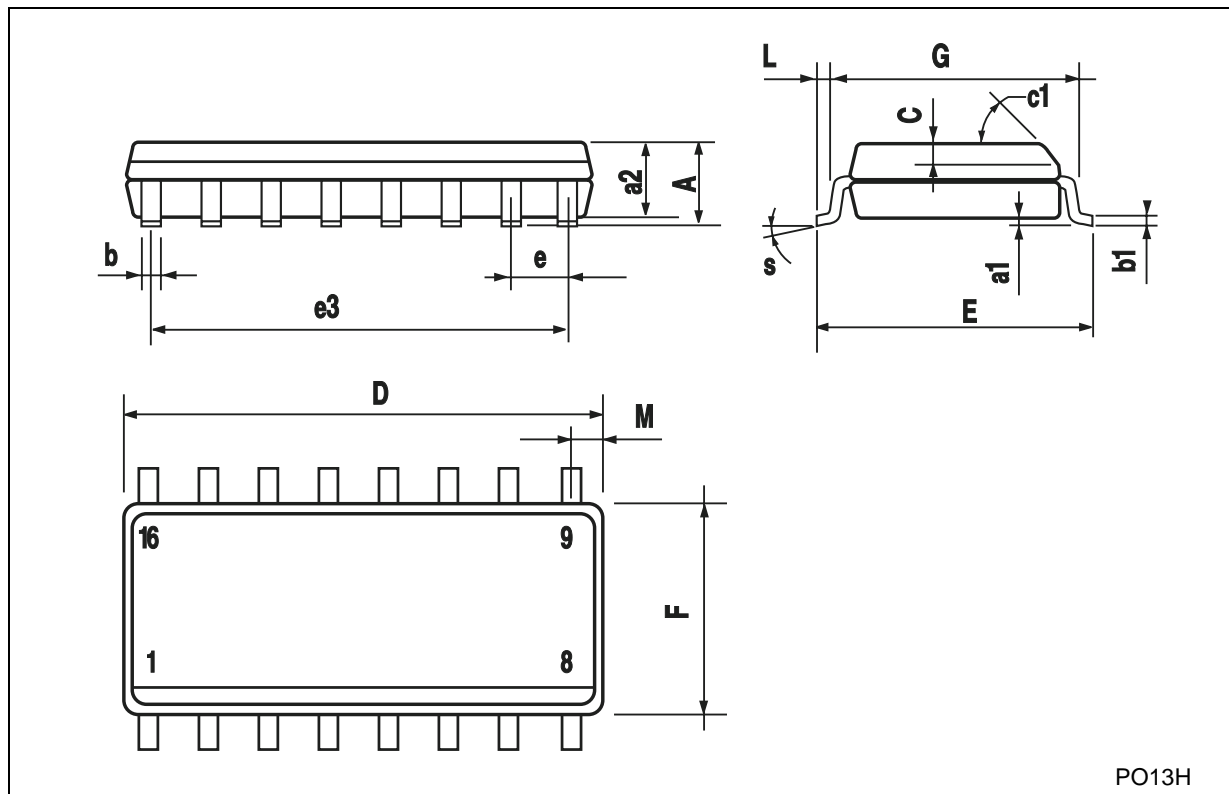

PO13H

Information furnished is believed to be accurate and reliable. However, STMicroelectronics assumes no responsibility for the consequences of use of such information nor for any infringement of patents or other rights of third parties which may result from its use. No license is granted by implication or otherwise under any patent or patent rights of STMicroelectronics. Specifications mentioned in this publication are subject to change without notice. This publication supersedes and replaces all information previously supplied. STMicroelectronics products are not authorized for use as critical components in life support devices or systems without express written approval of STMicroelectronics.

© The ST logo is a registered trademark of STMicroelectronics

© 2001 STMicroelectronics - Printed in Italy - All Rights Reserved
STMicroelectronics GROUP OF COMPANIES

Australia - Brazil - China - Finland - France - Germany - Hong Kong - India - Italy - Japan - Malaysia - Malta - Morocco
Singapore - Spain - Sweden - Switzerland - United Kingdom

© <http://www.st.com>