

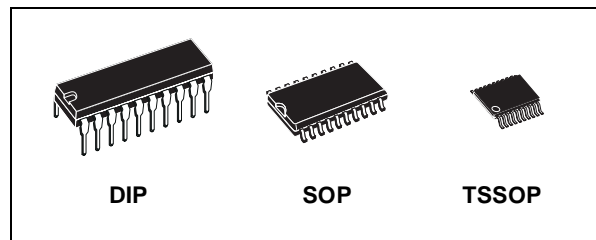

M74HC564

OCTAL D-TYPE FLIP FLOP WITH 3 STATE OUTPUT INVERTING

- HIGH SPEED:
 $f_{MAX} = 90\text{MHz}$ (TYP.) at $V_{CC} = 6\text{V}$
- LOW POWER DISSIPATION:
 $I_{CC} = 4\mu\text{A}$ (MAX.) at $T_A=25^\circ\text{C}$
- HIGH NOISE IMMUNITY:
 $V_{NIH} = V_{NIL} = 28\% V_{CC}$ (MIN.)
- SYMMETRICAL OUTPUT IMPEDANCE:
 $|I_{OH}| = I_{OL} = 6\text{mA}$ (MIN)
- BALANCED PROPAGATION DELAYS:
 $t_{PLH} \cong t_{PHL}$
- WIDE OPERATING VOLTAGE RANGE:
 V_{CC} (OPR) = 2V to 6V
- PIN AND FUNCTION COMPATIBLE WITH 74 SERIES 564



ORDER CODES

PACKAGE	TUBE	T & R
DIP	M74HC564B1R	
SOP	M74HC564M1R	M74HC564RM13TR
TSSOP		M74HC564TTR

DESCRIPTION

The M74HC564 is an high speed CMOS OCTAL D-TYPE FLIP FLOP WITH 3-STATE OUTPUTS INVERTING fabricated with silicon gate C²MOS technology.

This 8 bit D-TYPE FLIP FLOP is controlled by a clock input (CK) and an output enable input (\overline{OE}). On the positive transition of the clock, the Q outputs will be set to the logic state that were setup at the D inputs.

While the \overline{OE} input is at low level, the eight outputs will be in a normal logic state (high or low logic

level) and while high level the outputs will be in a high impedance state.

The output control does not affect the internal operation of flip-flops; that is, the old data can be retained or the new data can be entered even while the outputs are off.

All inputs are equipped with protection circuits against static discharge and transient excess voltage.

PIN CONNECTION AND IEC LOGIC SYMBOLS

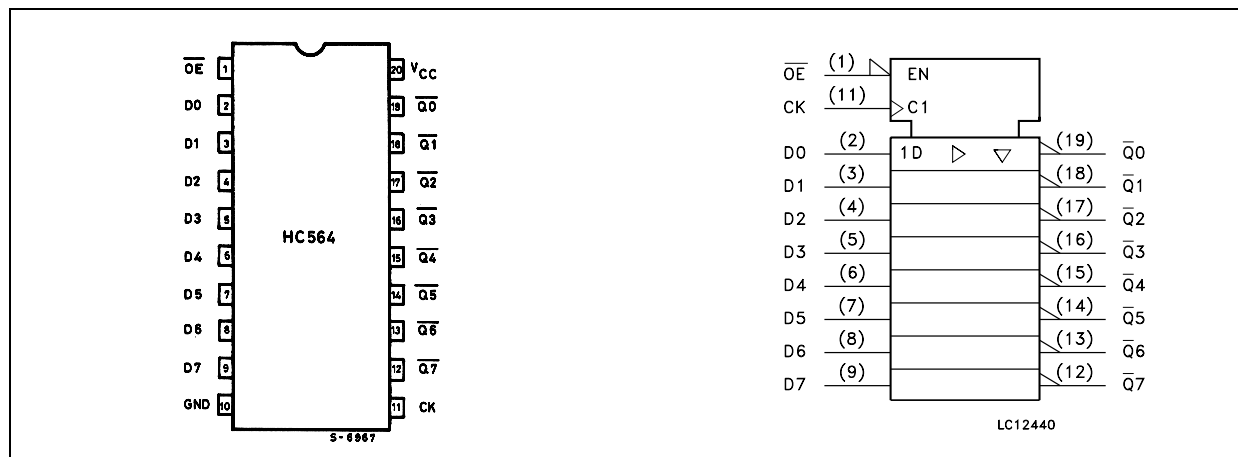

M74HC564

INPUT AND OUTPUT EQUIVALENT CIRCUIT

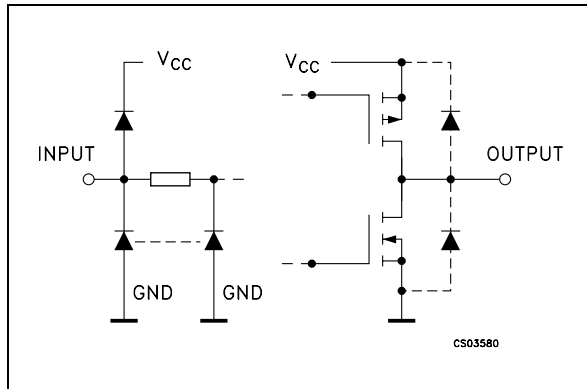

PIN DESCRIPTION

PIN No	SYMBOL	NAME AND FUNCTION
1	\overline{OE}	3 State Output Enable Input (Active LOW)
2, 3, 4, 5, 6, 7, 8, 9, 10	D0 to D7	Data Inputs
12, 13, 14, 15, 16, 17, 18, 19	Q0 to Q7	3 State Outputs
11	CLOCK	Clock Input (LOW to HIGH, edge triggered)
10	GND	Ground (0V)
20	V _{CC}	Positive Supply Voltage

TRUTH TABLE

INPUTS			OUTPUT
\overline{OE}	CK	D	\overline{Q}
H	X	X	Z
L		X	NO CHANGE
L		L	H
L		H	L

X: Don't Care
Z: High Impedance

LOGIC DIAGRAM

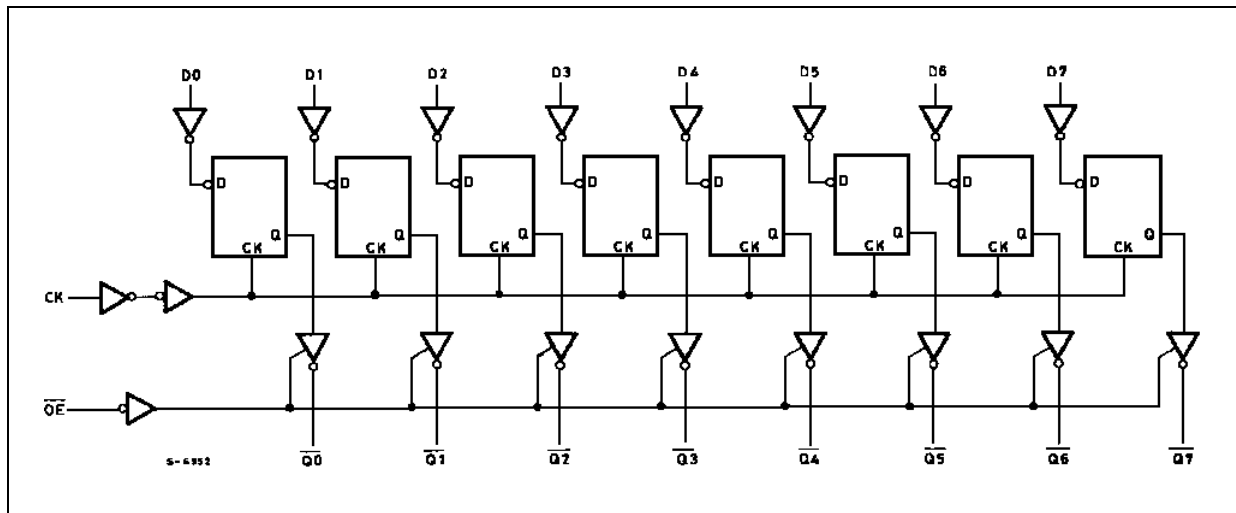

This logic diagram has not been used to estimate propagation delays

ABSOLUTE MAXIMUM RATINGS

Symbol	Parameter	Value	Unit
V_{CC}	Supply Voltage	-0.5 to +7	V
V_I	DC Input Voltage	-0.5 to $V_{CC} + 0.5$	V
V_O	DC Output Voltage	-0.5 to $V_{CC} + 0.5$	V
I_{IK}	DC Input Diode Current	± 20	mA
I_{OK}	DC Output Diode Current	± 20	mA
I_O	DC Output Current	± 35	mA
I_{CC} or I_{GND}	DC V_{CC} or Ground Current	± 70	mA
P_D	Power Dissipation	500(*)	mW
T_{stg}	Storage Temperature	-65 to +150	°C
T_L	Lead Temperature (10 sec)	300	°C

Absolute Maximum Ratings are those values beyond which damage to the device may occur. Functional operation under these conditions is not implied

(*) 500mW at 65 °C; derate to 300mW by 10mW/°C from 65°C to 85°C

RECOMMENDED OPERATING CONDITIONS

Symbol	Parameter	Value	Unit	
V_{CC}	Supply Voltage	2 to 6	V	
V_I	Input Voltage	0 to V_{CC}	V	
V_O	Output Voltage	0 to V_{CC}	V	
T_{op}	Operating Temperature	-55 to 125	°C	
t_r, t_f	Input Rise and Fall Time	$V_{CC} = 2.0V$	0 to 1000	ns
		$V_{CC} = 4.5V$	0 to 500	ns
		$V_{CC} = 6.0V$	0 to 400	ns

DC SPECIFICATION

Symbol	Parameter	Test Condition		Value						Unit	
		V _{CC} (V)		T _A = 25°C			-40 to 85°C		-55 to 125°C		
				Min.	Typ.	Max.	Min.	Max.	Min.		Max.
V _{IH}	High Level Input Voltage	2.0		1.5			1.5		1.5		V
		4.5		3.15			3.15		3.15		
		6.0		4.2			4.2		4.2		
V _{IL}	Low Level Input Voltage	2.0				0.5		0.5		0.5	V
		4.5				1.35		1.35		1.35	
		6.0				1.8		1.8		1.8	
V _{OH}	High Level Output Voltage	2.0	I _O =-20 μA	1.9	2.0		1.9		1.9		V
		4.5	I _O =-20 μA	4.4	4.5		4.4		4.4		
		6.0	I _O =-20 μA	5.9	6.0		5.9		5.9		
		4.5	I _O =-6.0 mA	4.18	4.31		4.13		4.10		
		6.0	I _O =-7.8 mA	5.68	5.8		5.63		5.60		
V _{OL}	Low Level Output Voltage	2.0	I _O =20 μA		0.0	0.1		0.1		0.1	V
		4.5	I _O =20 μA		0.0	0.1		0.1		0.1	
		6.0	I _O =20 μA		0.0	0.1		0.1		0.1	
		4.5	I _O =6.0 mA		0.17	0.26		0.33		0.40	
		6.0	I _O =7.8 mA		0.18	0.26		0.33		0.40	
I _I	Input Leakage Current	6.0	V _I = V _{CC} or GND			± 0.1		± 1		± 1	μA
I _{OZ}	High Impedance Output Leakage Current	6.0	V _I = V _{IH} or V _{IL} V _O = V _{CC} or GND			± 0.5		± 5		± 10	μA
I _{CC}	Quiescent Supply Current	6.0	V _I = V _{CC} or GND			4		40		80	μA

AC ELECTRICAL CHARACTERISTICS ($C_L = 50 \text{ pF}$, Input $t_r = t_f = 6 \text{ ns}$)

Symbol	Parameter	Test Condition			Value						Unit	
		V_{CC} (V)	C_L (pF)		$T_A = 25^\circ\text{C}$			$-40 \text{ to } 85^\circ\text{C}$		$-55 \text{ to } 125^\circ\text{C}$		
					Min.	Typ.	Max.	Min.	Max.	Min.		Max.
t_{TLH} t_{THL}	Output Transition Time	2.0	50			25	60		75		90	ns
		4.5			7	12		15		18		
		6.0			6	10		13		15		
t_{PLH} t_{PHL}	Propagation Delay Time (CK - \bar{Q})	2.0	50		70	150		190		225	ns	
		4.5			20	30		38		45		
		6.0			15	26		32		38		
		2.0	150		88	190		240		285	ns	
		4.5			25	38		48		57		
		6.0			19	32		41		48		
t_{PZL} t_{PZH}	High Impedance Output Enable Time	2.0	50	$R_L = 1 \text{ K}\Omega$		48	125		155		190	ns
		4.5				15	25		31		38	
		6.0				12	21		26		32	
		2.0	150	$R_L = 1 \text{ K}\Omega$		60	165		205		250	ns
		4.5				20	33		41		50	
		6.0				16	28		35		43	
t_{PLZ} t_{PHZ}	High Impedance Output Disable Time	2.0	50	$R_L = 1 \text{ K}\Omega$		34	125		155		190	ns
		4.5				17	25		31		38	
		6.0				15	21		26		32	
f_{MAX}	Maximum Clock Frequency	2.0	50		6.2	18		5		4.2	MHz	
		4.5			31	75		25		21		
		6.0			37	90		30		25		
$t_{W(L)}$ $t_{W(H)}$	Minimum Pulse Width (CK)	2.0	50			15	75		95		110	ns
		4.5			6	15		19		22		
		6.0			6	13		16		19		
t_s	Minimum Set-up Time	2.0	50			25	75		95		110	ns
		4.5			6	15		19		22		
		6.0			4	13		16		19		
t_h	Minimum Hold Time	2.0	50				0		0		0	ns
		4.5				0		0		0		
		6.0				0		0		0		

CAPACITIVE CHARACTERISTICS

Symbol	Parameter	Test Condition			Value						Unit	
		V_{CC} (V)			$T_A = 25^\circ\text{C}$			$-40 \text{ to } 85^\circ\text{C}$		$-55 \text{ to } 125^\circ\text{C}$		
					Min.	Typ.	Max.	Min.	Max.	Min.		Max.
C_{IN}	Input Capacitance					5	10		10		10	pF
C_{OUT}	Output Capacitance					10						pF
C_{PD}	Power Dissipation Capacitance (note 1)					54						pF

1) C_{PD} is defined as the value of the IC's internal equivalent capacitance which is calculated from the operating current consumption without load. (Refer to Test Circuit). Average operating current can be obtained by the following equation. $I_{CC(opr)} = C_{PD} \times V_{CC} \times f_{IN} + I_{CC}/8$ (per flip-flop)

TEST CIRCUIT

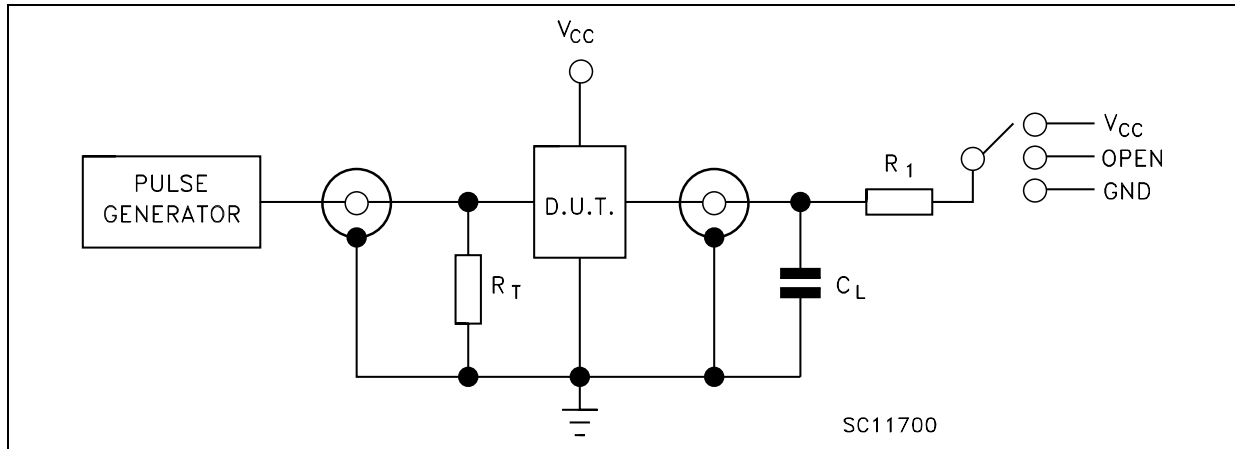

TEST	SWITCH
t_{PLH} , t_{PHL}	Open
t_{PZL} , t_{PLZ}	V_{CC}
t_{PZH} , t_{PHZ}	GND

C_L = 50pF/150pF or equivalent (includes jig and probe capacitance)
 R_1 = 1K Ω or equivalent
 R_T = Z_{OUT} of pulse generator (typically 50 Ω)

WAVEFORM 1: CK TO \overline{Qn} PROPAGATION DELAYS, Dn TO CK SETUP AND HOLD TIMES, CK MAXIMUM FREQUENCY ($f=1\text{MHz}$; 50% duty cycle)

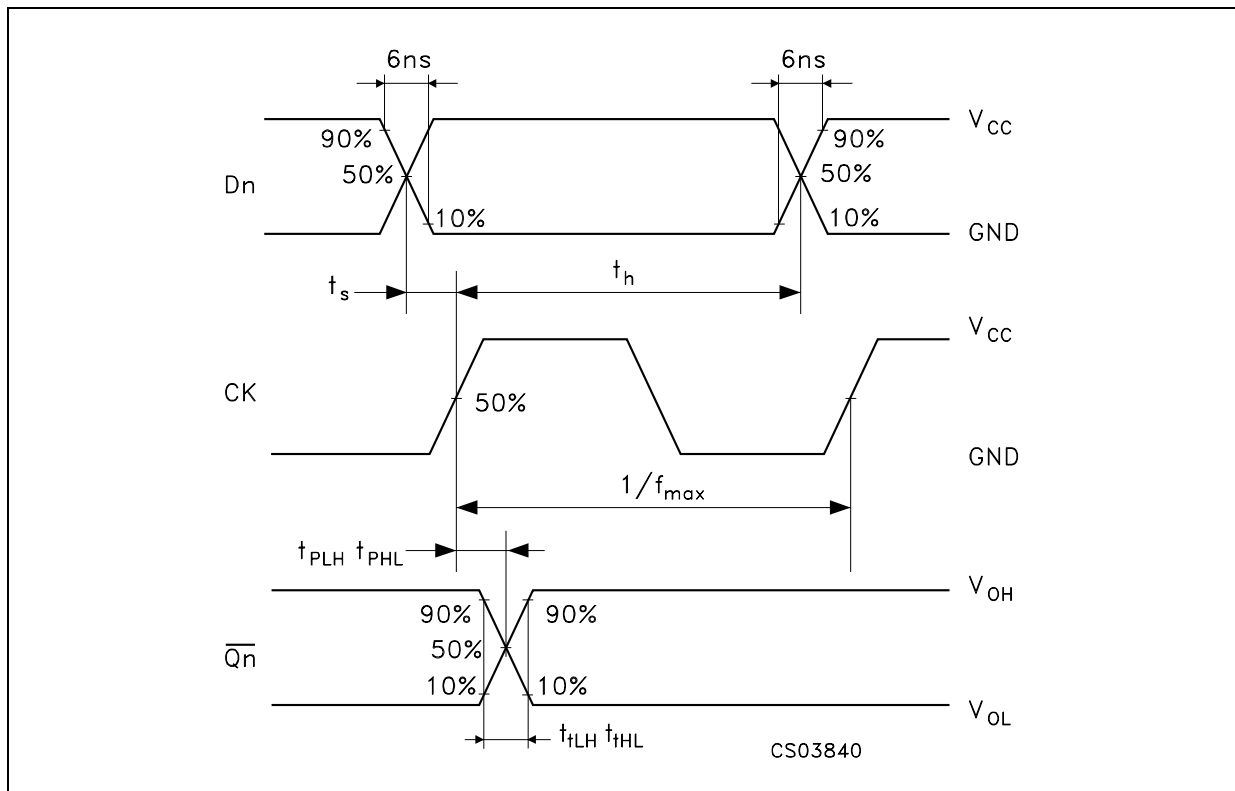

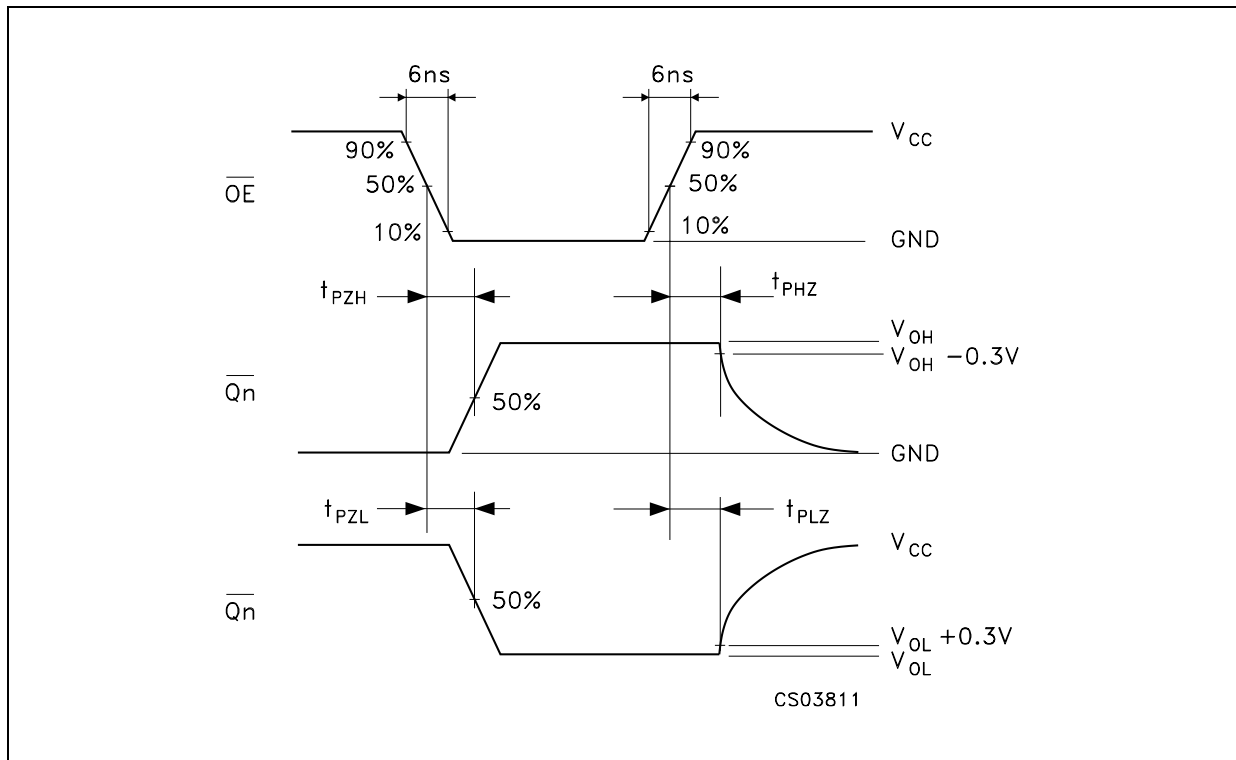
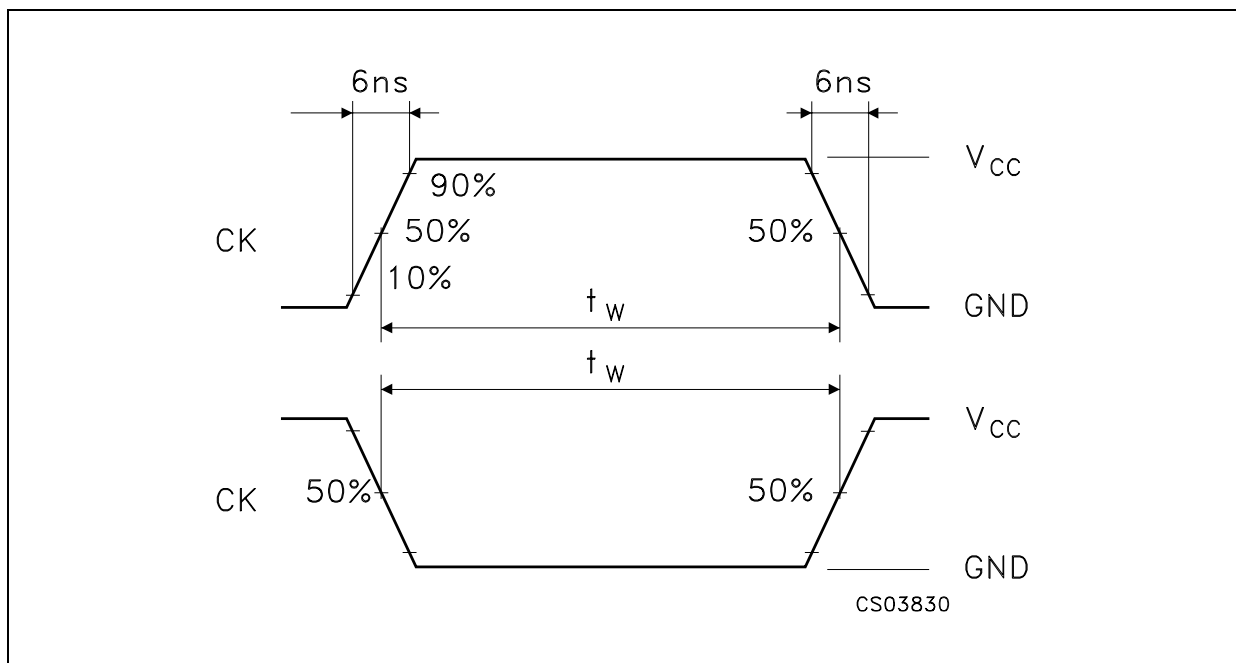
WAVEFORM 2: OUTPUT ENABLE AND DISABLE TIMES ($f=1\text{MHz}$; 50% duty cycle)**WAVEFORM 3: CK MINIMUM PULSE WIDTH** ($f=1\text{MHz}$; 50% duty cycle)

Plastic DIP-20 (0.25) MECHANICAL DATA

DIM.	mm.			inch		
	MIN.	TYP	MAX.	MIN.	TYP.	MAX.
a1	0.254			0.010		
B	1.39		1.65	0.055		0.065
b		0.45			0.018	
b1		0.25			0.010	
D			25.4			1.000
E		8.5			0.335	
e		2.54			0.100	
e3		22.86			0.900	
F			7.1			0.280
I			3.93			0.155
L		3.3			0.130	
Z			1.34			0.053

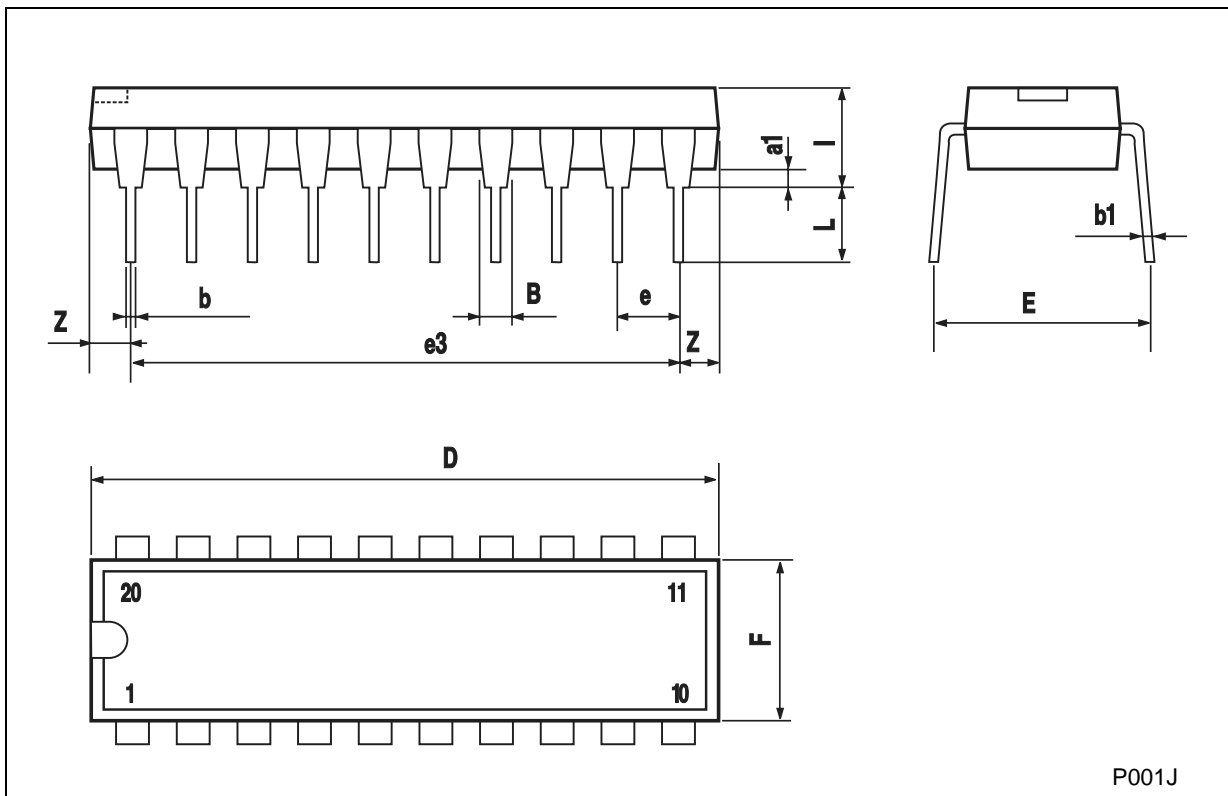

P001J

SO-20 MECHANICAL DATA

DIM.	mm.			inch		
	MIN.	TYP.	MAX.	MIN.	TYP.	MAX.
A			2.65			0.104
a1	0.1		0.2	0.004		0.008
a2			2.45			0.096
b	0.35		0.49	0.014		0.019
b1	0.23		0.32	0.009		0.012
C		0.5			0.020	
c1	45° (typ.)					
D	12.60		13.00	0.496		0.512
E	10.00		10.65	0.393		0.419
e		1.27			0.050	
e3		11.43			0.450	
F	7.40		7.60	0.291		0.300
L	0.50		1.27	0.020		0.050
M			0.75			0.029
S	8° (max.)					

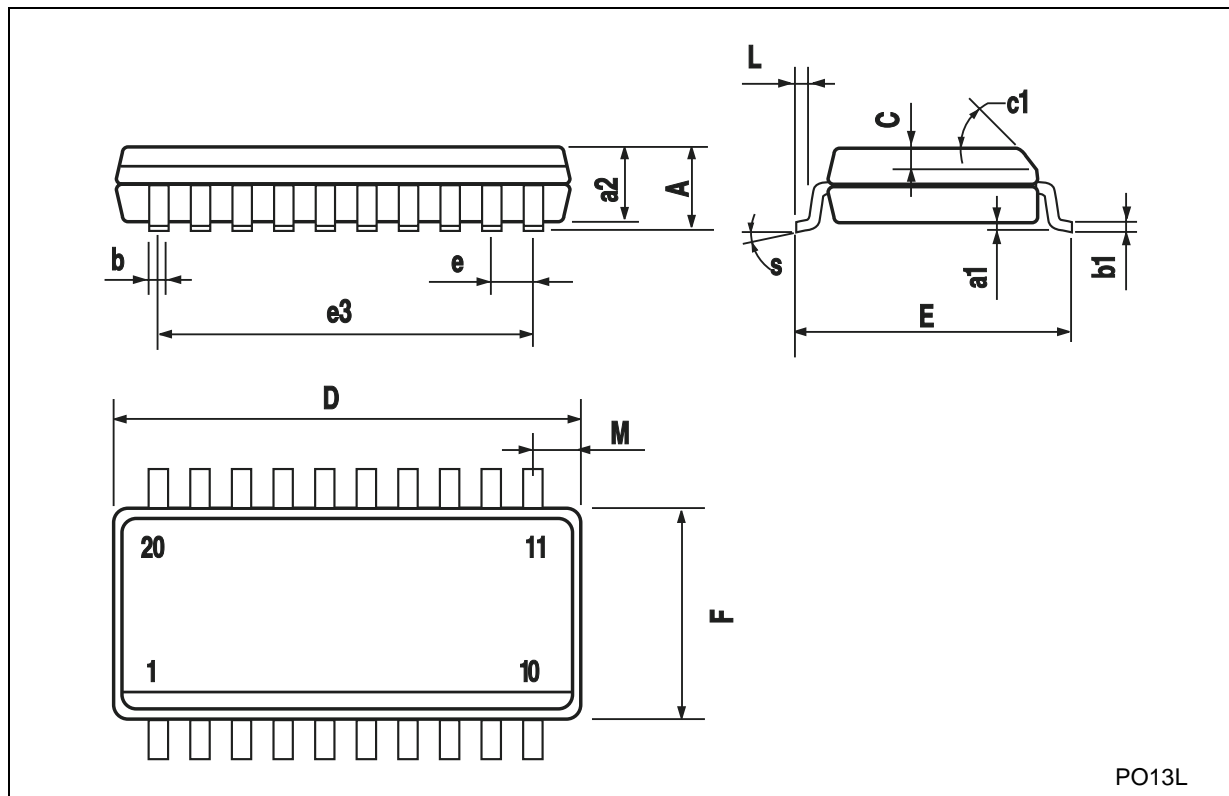

TSSOP20 MECHANICAL DATA

DIM.	mm.			inch		
	MIN.	TYP	MAX.	MIN.	TYP.	MAX.
A			1.2			0.047
A1	0.05		0.15	0.002	0.004	0.006
A2	0.8	1	1.05	0.031	0.039	0.041
b	0.19		0.30	0.007		0.012
c	0.09		0.20	0.004		0.0089
D	6.4	6.5	6.6	0.252	0.256	0.260
E	6.2	6.4	6.6	0.244	0.252	0.260
E1	4.3	4.4	4.48	0.169	0.173	0.176
e		0.65 BSC			0.0256 BSC	
K	0°		8°	0°		8°
L	0.45	0.60	0.75	0.018	0.024	0.030

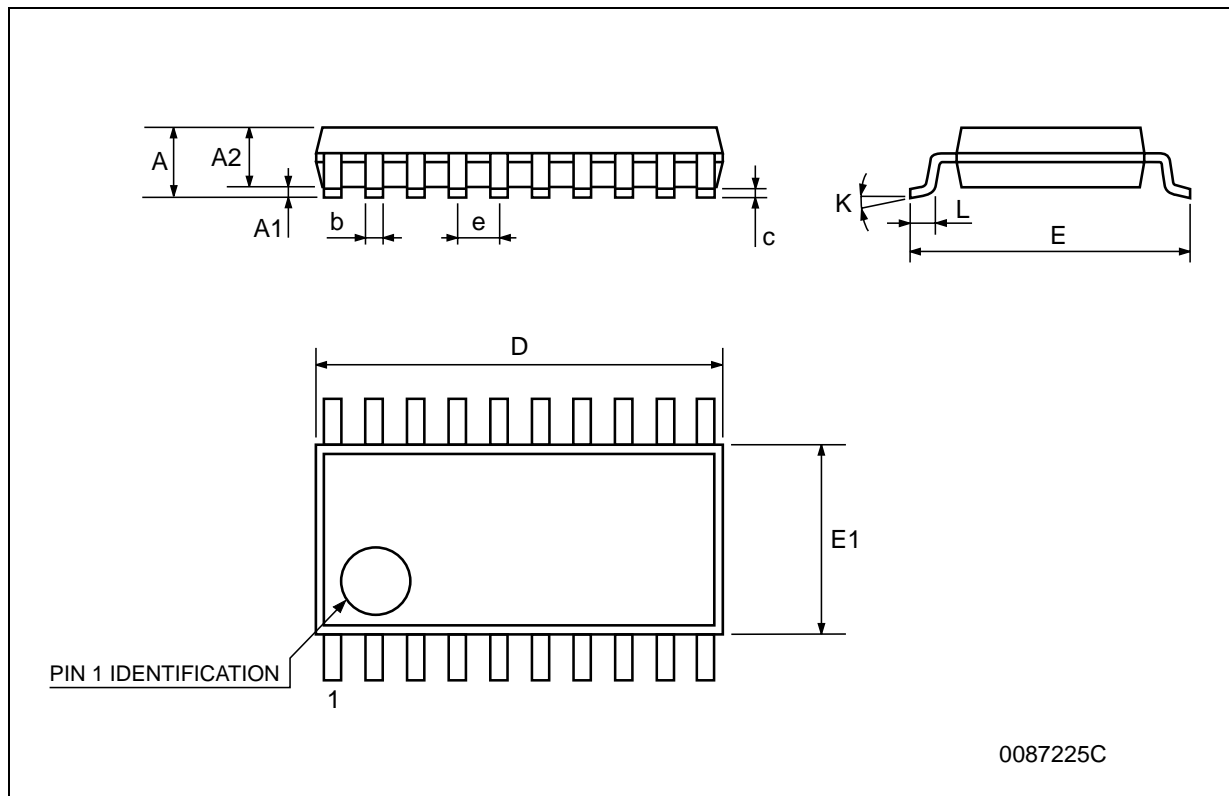

Information furnished is believed to be accurate and reliable. However, STMicroelectronics assumes no responsibility for the consequences of use of such information nor for any infringement of patents or other rights of third parties which may result from its use. No license is granted by implication or otherwise under any patent or patent rights of STMicroelectronics. Specifications mentioned in this publication are subject to change without notice. This publication supersedes and replaces all information previously supplied. STMicroelectronics products are not authorized for use as critical components in life support devices or systems without express written approval of STMicroelectronics.

© The ST logo is a registered trademark of STMicroelectronics

© 2000 STMicroelectronics - Printed in Italy - All Rights Reserved
STMicroelectronics GROUP OF COMPANIES

Australia - Brazil - China - Finland - France - Germany - Hong Kong - India - Italy - Japan - Malaysia - Malta - Morocco
Singapore - Spain - Sweden - Switzerland - United Kingdom

© <http://www.st.com>

