



FLC10-200H/B

Application Specific Discretes
A.S.D.™

FIRE LIGHTER CIRCUIT

FEATURES

- Dedicated thyristor structure for capacitance discharge ignition operation
- High pulse current capability
240A @ $t_p = 10\mu s$
- Fast turn-on operation
- Designed for high ambient temperature (up to 120°C)

BENEFITS

- Space saving thanks to monolithic function integration
- High reliability with planar technology

DESCRIPTION

The FLC10 series has been especially developed for high power capacitance discharge operation. The main applications are gas lighters or ignitors such as :
cookers / gas boilers / gas hobs...

Based on ST's ASD™ technology, it provides a fully integrated function, with high performance and reliability levels, adapted to severe and hot temperature environment.

Th: Thyristor for switching operation.

Z: Zener diode to set the threshold voltage.

D: Diode for reverse conduction.

R: 2 kΩ resistor.

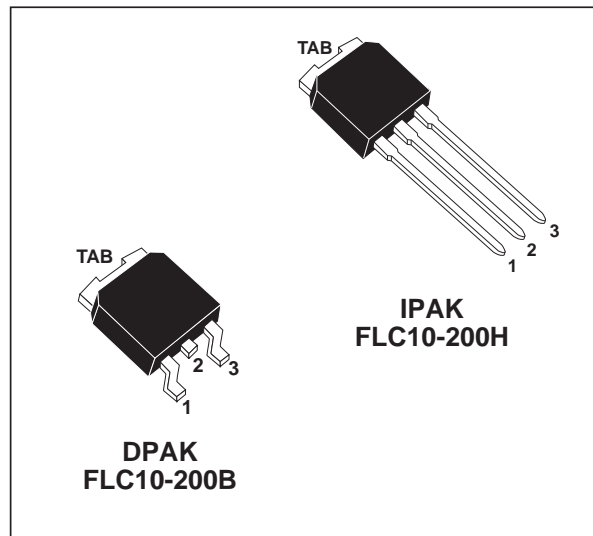

FUNCTIONAL DIAGRAM

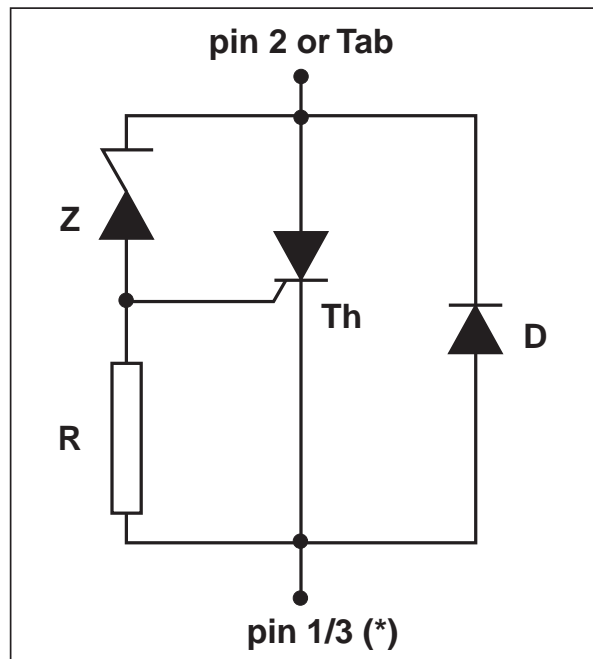

(*) Pin1 and Pin3 must be shorted together in the application circuit layout.

FLC10-200H/B

ABSOLUTE RATINGS (limiting values)

Symbol	Parameter	Value	Unit
I_{TRM}	Repetitive surge peak on state current for thyristor $-30^{\circ}\text{C} \leq T_{amb} \leq 120^{\circ}\text{C}$	240	A
I_{FRM}	Repetitive surge peak on state current for diode $-30^{\circ}\text{C} \leq T_{amb} \leq 120^{\circ}\text{C}$		
di/dt	Critical rate of rise time on state current $-30^{\circ}\text{C} \leq T_{amb} \leq 120^{\circ}\text{C}$	200	A/ μs
T_{stg} T_j	Storage junction temperature range Maximum junction temperature	- 40 to + 150 + 125	$^{\circ}\text{C}$
T_{oper}	Operating temperature range	-30 + 120	$^{\circ}\text{C}$
T_L	Maximum lead temperature for soldering during 10s	260	$^{\circ}\text{C}$

Note 1 : Test current waveform

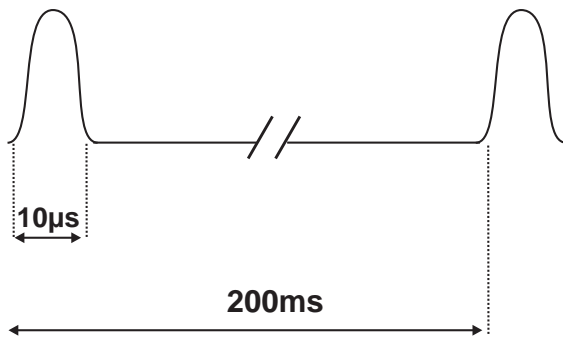

THERMAL RESISTANCE

Symbol	Parameter	Value	Unit
$R_{th(j-a)}$	IPAK thermal resistance junction to ambient	100	$^{\circ}\text{C}/\text{W}$
$R_{th(j-a)}$	DPAK thermal resistance junction to ambient $S = 0.5\text{cm}^2$	70	$^{\circ}\text{C}/\text{W}$

S = Copper Surface under Tab

ORDERING INFORMATION

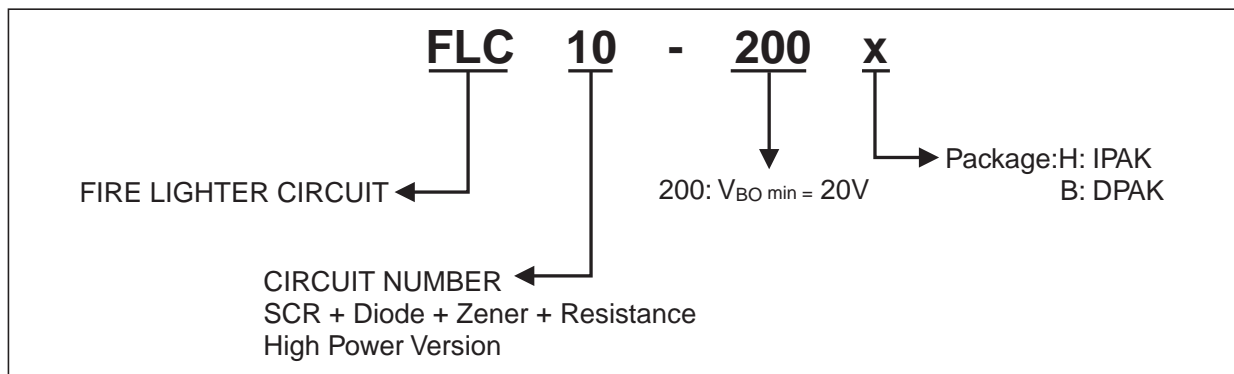

ELECTRICAL CHARACTERISTICS

Symbol	Parameters
V_{RM}	Stand-off voltage
V_{BO}	Breakover voltage
V_T	On-state voltage
V_F	Diode forward voltage drop
I_{BO}	Breakover current
I_{RM}	Leakage current
αT	Temperature coefficient for V_{BO}

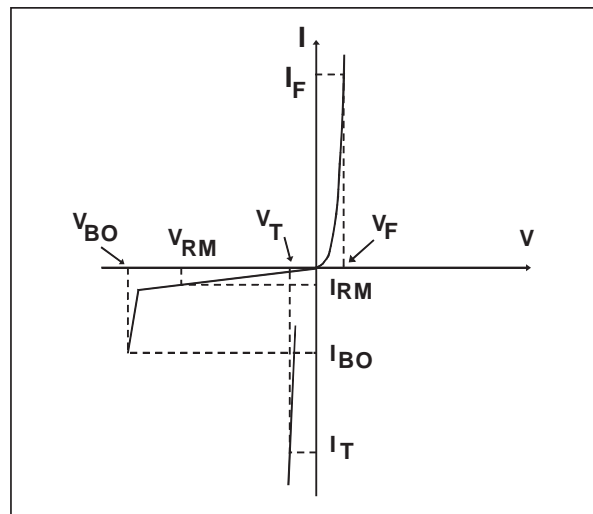

DIODE (D) PARAMETER

Symbol	Test Conditions			Value	Unit	
V_F	$I_F = 2A$	$t_p \leq 500\mu s$	$T_j = 25^\circ C$	Max.	1.7	V

THYRISTOR (Th) and ZENER (Z) PARAMETERS

Symbol	Test conditions		Min	Typ	Max	Unit
I_{RM}	$V_{RM} = 200 V$	$T_j = 25^\circ C$			10	μA
		$T_j = 125^\circ C$			100	μA
V_{BO}	at I_{BO}	$T_j = 25^\circ C$	200	225	250	V
I_{BO}	at V_{BO}	$T_j = 25^\circ C$			0.5	mA
V_T	$I_T = 2A$	$t_p \leq 500\mu s$			1.7	V
αT				13		$10^{-4}/^\circ C$

Fig. 1: Relative variation of breakover current versus junction temperature.

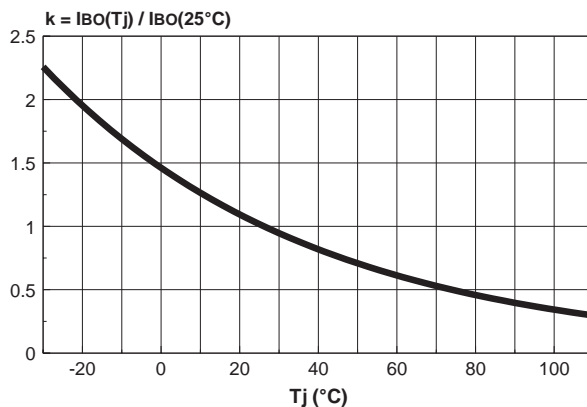
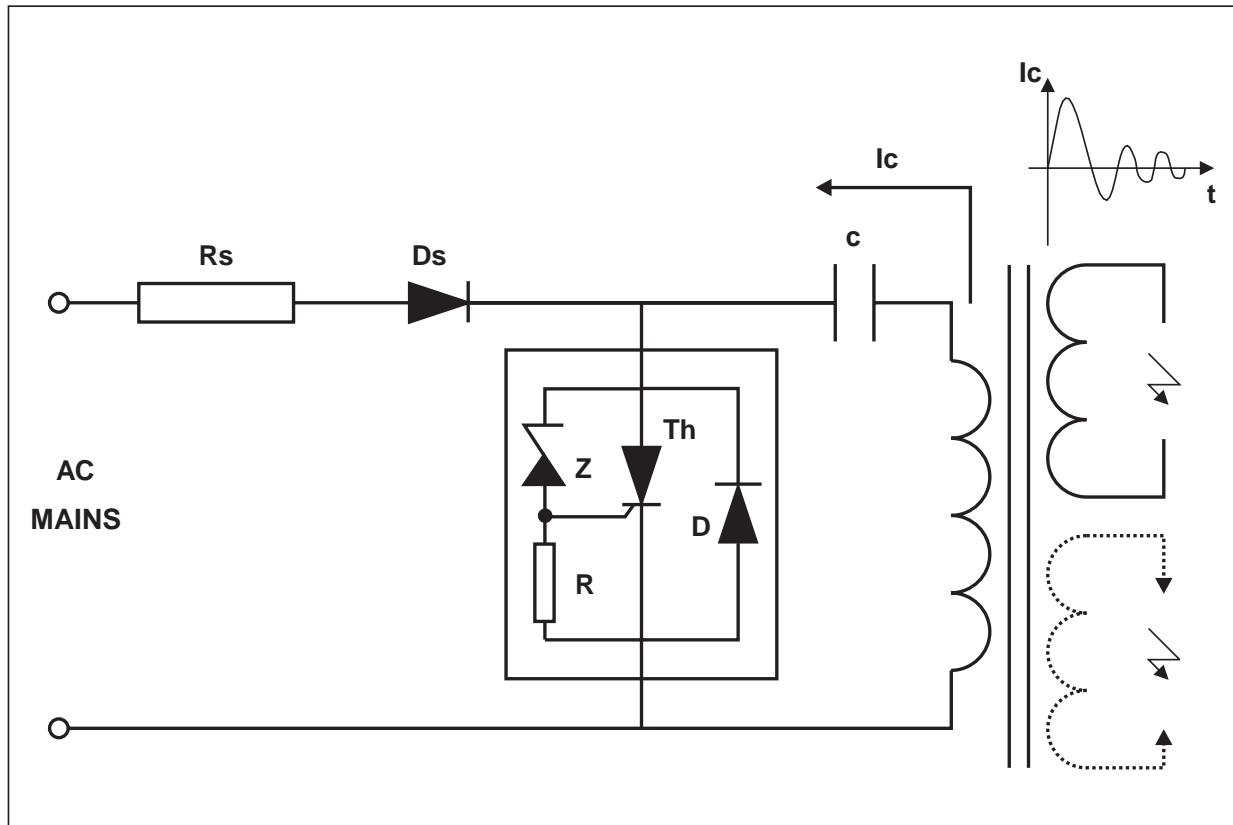

Fig. 2: BASIC APPLICATION



The applications of the lighter using the capacitance discharge topology operate in 2 phases :

PHASE 1

The energy coming from the mains is stored into the capacitor C. For that, the AC voltage is rectified by the diode Ds.

PHASE 2

At the end of the phase 1, the voltage across the capacitor C reaches the avalanche threshold of the zener. Then a current flows through the gate of the thyristor Th which fires. The firing of the thyristor causes an alternating current to flow through the capacitor C. The positive parts of this current flow through C, Th and the primary of the HV transformer. The negative parts of the current flow through C, D and the primaty of the HV transformer.

COMPONENT CHOICE

RS RESISTOR CALCULATION

The Rs resistor allows, in addition with the capacitor C, the spark frequency to be adjusted and the current from the mains to be limited. Its value shall allow the thyristor Th to fire even in worst case conditions. In this borderline case, the system must fire with the lowest value of RMS mains voltage while the breakdown voltage and current of the FLC are at the maximum.

The maximum Rs value is equal to :

$$R_{smax} = \frac{(V_{AC} \text{ min.} \cdot \sqrt{2}) - [V_{BO} \text{ max.} \cdot (1 + \alpha \cdot T \cdot (T_{amb} - 25))]}{k \cdot I_{BO}^*}$$

* : see fig 1

Fig. 3: Spark frequency versus R_s and C

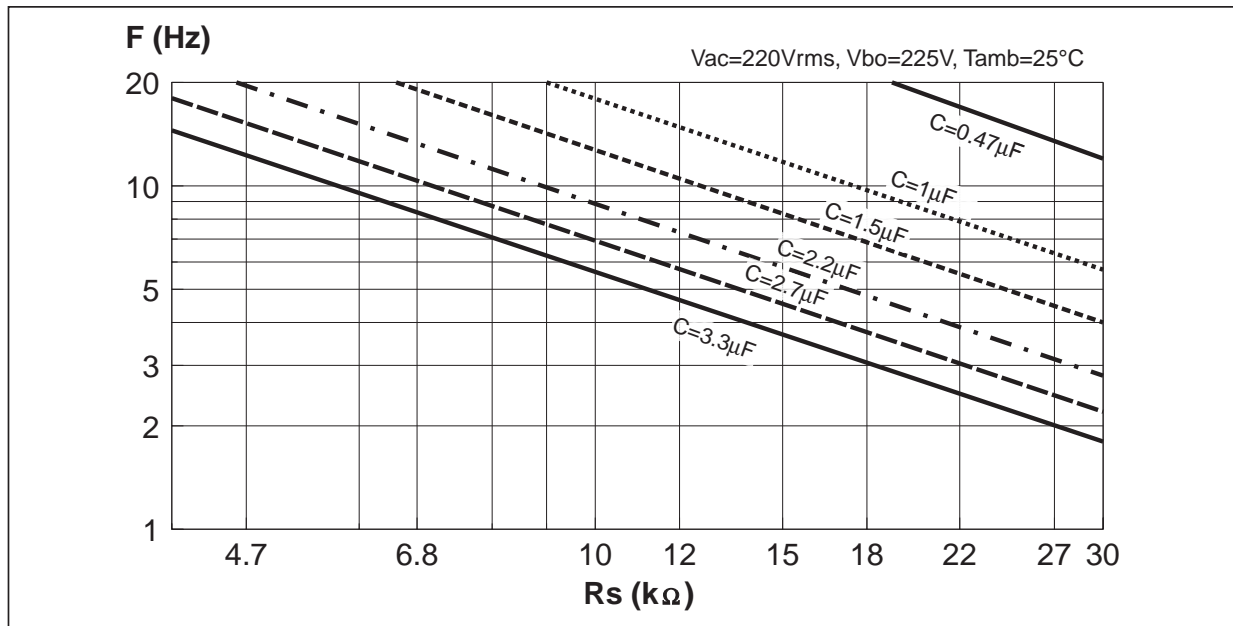

The couple R_s/C can be chosen with the previous curve. Keep in mind the R_s maximum limit for which the system would not work when the AC

mains is minimum. The next curve shows the behavior with $R_s=15k\Omega$ and $C=1\mu F$.

Fig. 4: Voltage across the capacitance with $R_s = 15k\Omega$, $C = 1\mu F$ and $V_{BO} = 225V$.

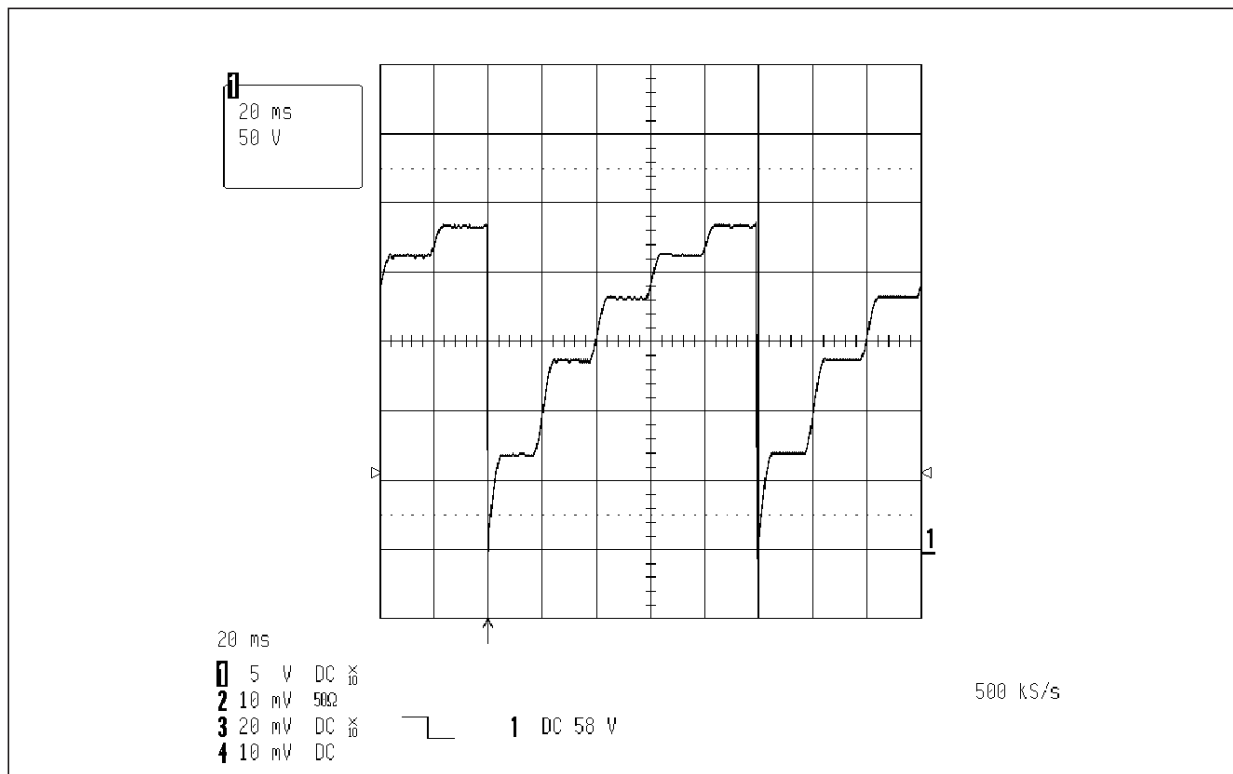

PEAK CURRENT LIMIT

This component is designed to withstand $I_{TRM} = 240A$ for a pulse duration of $10\mu s$ for an ambient temperature of $120^{\circ}C$ in repetitive surge (see note 1, page 2).

The curve of peak current versus the pulse duration allows us to verify if the application is within the FLC operating limit.

Fig. 5: Peak current limit versus pulse duration.

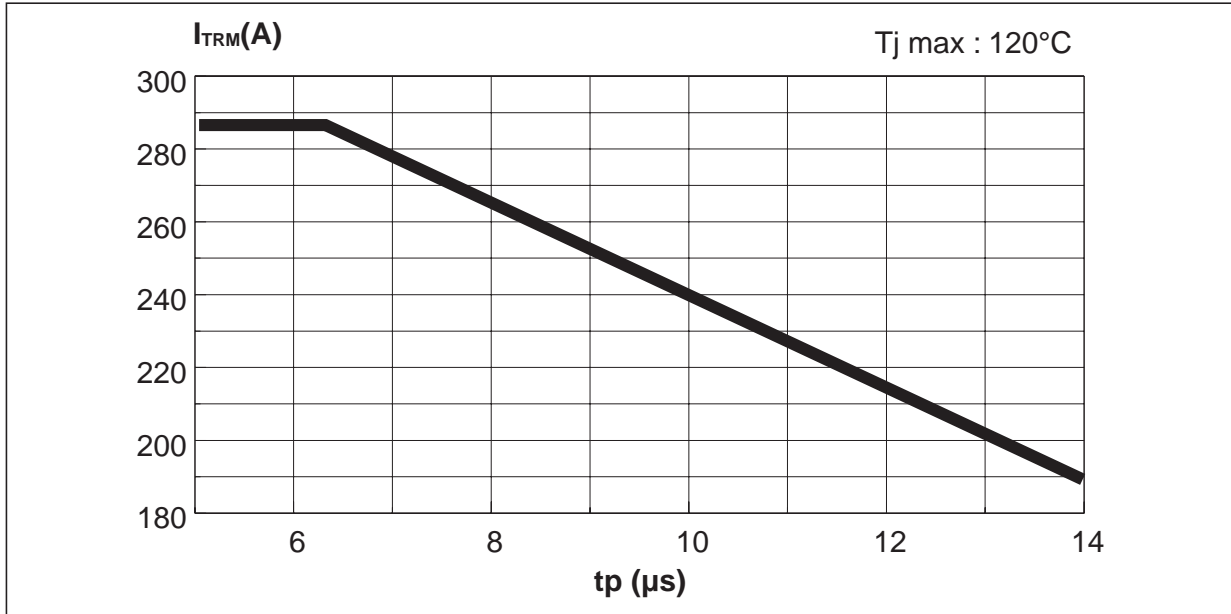

POWER LOSSES (For $10\mu s$, see note 1)

To evaluate the power losses, please use the following equations :

For the thyristor : $P = 1.18 \times I_{T(AV)} + 0.035 I_{T(RMS)}^2$

For the diode : $P = 0.67 \times I_{F(AV)} + 0.106 I_{F(RMS)}^2$

PACKAGE MECHANICAL DATA
DPAK

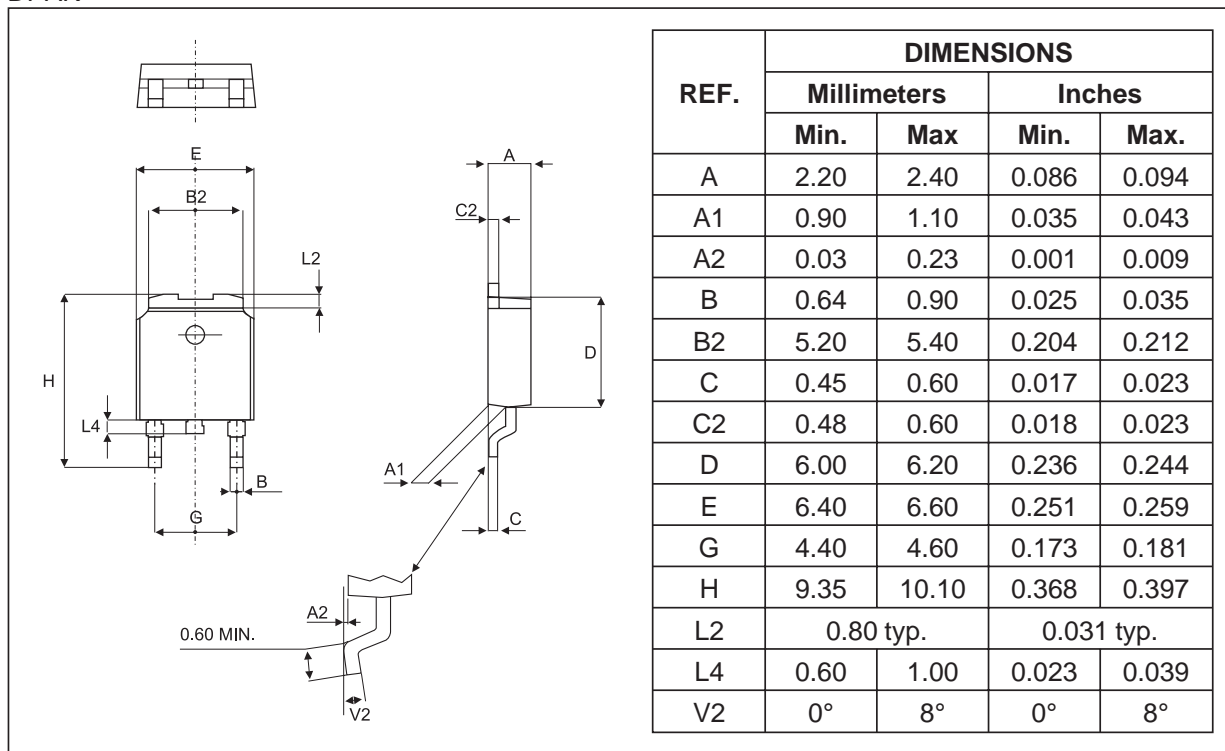

FOOTPRINT

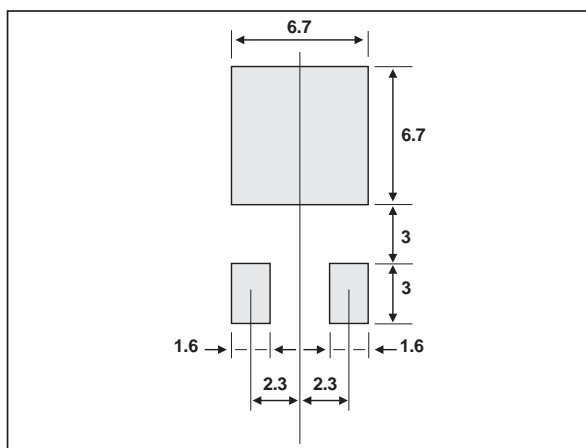

FLC10-200H/B

PACKAGE MECHANICAL DATA IPAK

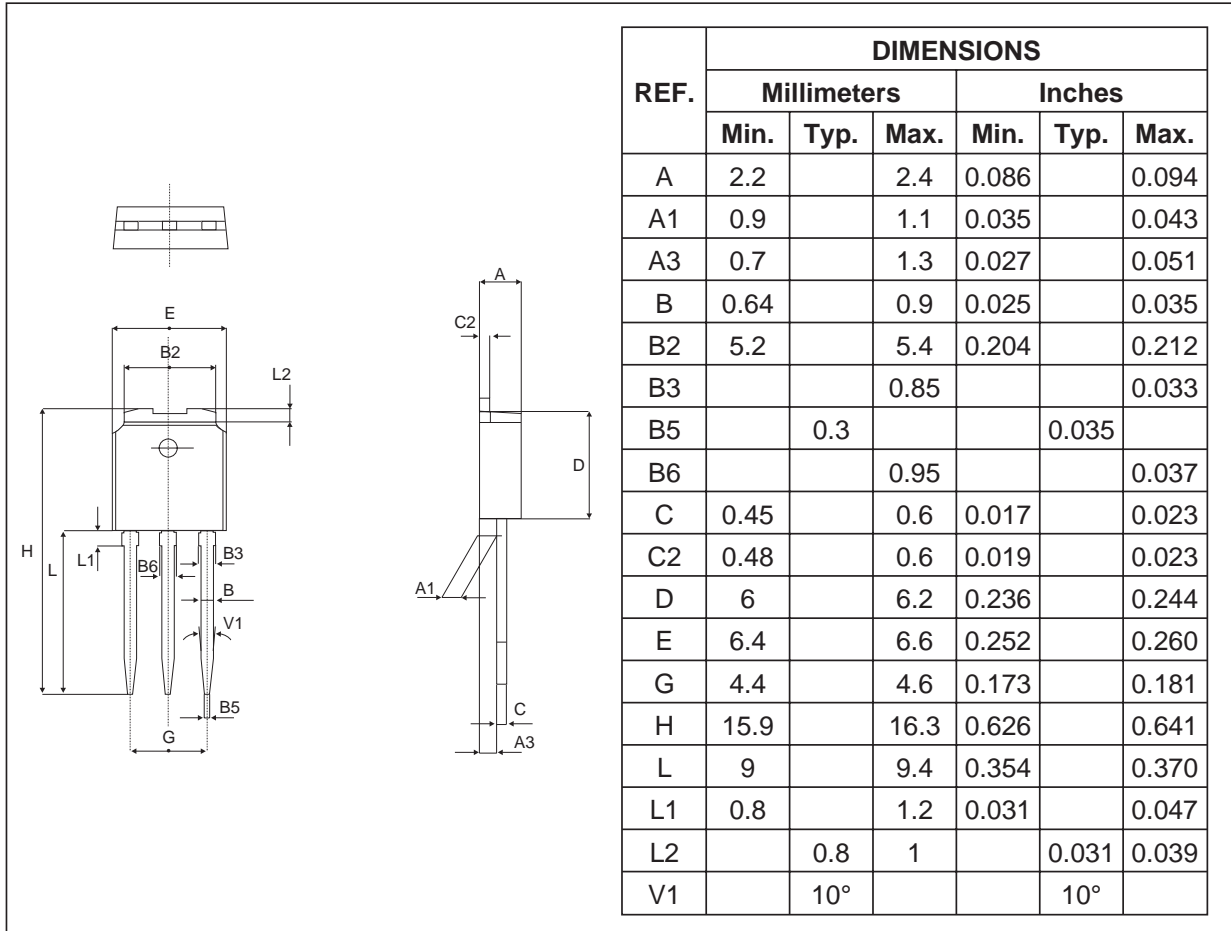

OTHER INFORMATION

Type	Marking	Package	Weight	Base qty	Delivery mode
FLC10-200H	FLC10-200H	IPAK	0.40 g	75	Tube
FLC10-200B	FLC10-200B	DPAK	0.3 g	75	Tube

Information furnished is believed to be accurate and reliable. However, STMicroelectronics assumes no responsibility for the consequences of use of such information nor for any infringement of patents or other rights of third parties which may result from its use. No license is granted by implication or otherwise under any patent or patent rights of STMicroelectronics. Specifications mentioned in this publication are subject to change without notice. This publication supersedes and replaces all information previously supplied. STMicroelectronics products are not authorized for use as critical components in life support devices or systems without express written approval of STMicroelectronics.

The ST logo is a registered trademark of STMicroelectronics

© 2001 STMicroelectronics - Printed in Italy - All rights reserved.

STMicroelectronics GROUP OF COMPANIES

Australia - Brazil - China - Finland - France - Germany - Hong Kong - India - Italy - Japan - Malaysia
Malta - Morocco - Singapore - Spain - Sweden - Switzerland - United Kingdom - U.S.A.

<http://www.st.com>