



LSM330DL

Linear sensor module 3D accelerometer sensor and 3D gyroscope sensor

Preliminary data

Features

- Analog supply voltage 2.4 V to 3.6 V
- Digital supply voltage I/Os, 1.8V
- Low-power mode
- Power-down mode
- 3 independent acceleration channels and 3 angular rate channels
- $\pm 2g/\pm 4g/\pm 8g/\pm 16g$ dynamic, selectable full-scale acceleration range
- $\pm 250/\pm 500/\pm 2000$ dps dynamic, selectable full-scale angular rate
- SPI/I²C serial interface (16-bit data output)
- Programmable interrupt generator for free-fall and motion detection
- ECOPACK[®], RoHS, and “Green” compliant

Applications

- GPS navigation systems
- Impact recognition and logging
- Gaming and virtual reality input devices
- Motion-activated functions
- Intelligent power saving for handheld devices
- Vibration monitoring and compensation
- Free-fall detection
- 6D-orientation detection

Description

The LSM330DL is a system-in-package featuring a 3D digital accelerometer and a 3D digital gyroscope.

Table 1. Device summary

Part number	Temperature range [°C]	Package	Packing
LSM330DL	-40 to +85	LGA-28	Tray
LSM330DLTR	-40 to +85	LGA-28	Tape & reel

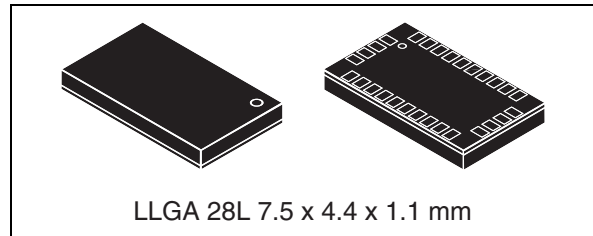

ST's family of modules leverages a robust and mature manufacturing process already used for the production of micromachined accelerometers.

The various sensing elements are manufactured using specialized micromachining processes, while the IC interfaces are based on CMOS technology that allows designing a dedicated circuit which is trimmed to better match the sensing element characteristics.

The LSM330DL has a dynamic, user-selectable full-scale acceleration range of $\pm 2g/\pm 4g/\pm 8g/\pm 16g$ and an angular rate of $\pm 250/\pm 500/\pm 2000$ deg/sec.

The accelerometer and gyroscope sensors can be either activated or put in low-power / power-down mode separately for power-saving optimized applications. The LSM330DL is available in a plastic land grid array (LGA) package.

Several years ago ST successfully pioneered the use of this package for accelerometers. Today, ST has the broadest manufacturing capability in the world and unrivalled expertise for the production of sensors in a plastic LGA package.

Contents

1	Block diagram and pin description	9
1.1	Block diagram	9
1.2	Pin description	10
2	Module specifications	12
2.1	Mechanical characteristics	12
2.2	Electrical characteristics	13
2.3	Temperature sensor characteristics	13
2.4	Communication interface characteristics	14
2.4.1	SPI - serial peripheral interface	14
2.4.2	I2C - inter-IC control interface	15
2.5	Absolute maximum ratings	16
2.6	Terminology	17
2.6.1	Sensitivity	17
2.6.2	Zero level	17
3	Functionality	18
3.1	Factory calibration	18
4	Application hints	19
4.1	External capacitors	19
4.2	Soldering information	20
5	Digital interfaces	21
5.1	I2C serial interface	21
5.1.1	I2C operation	22
5.2	SPI bus interface	24
5.2.1	SPI read	25
5.2.2	SPI write	25
5.2.3	SPI read in 3-wire mode	26
6	Register mapping	27

7	Registers description	29
7.1	CTRL_REG1_A (20h)	29
7.2	CTRL_REG2_A (21h)	30
7.3	CTRL_REG3_A (22h)	31
7.4	CTRL_REG4_A (23h)	31
7.5	CTRL_REG5_A (24h)	32
7.6	CTRL_REG6_A (25h)	32
7.7	REFERENCE/DATACAPTURE_A (26h)	32
7.8	STATUS_REG_A (27h)	33
7.9	OUT_X_L_A (28h), OUT_X_H_A (29h)	33
7.10	OUT_Y_L_A (2Ah), OUT_Y_H_A (2Bh)	33
7.11	OUT_Z_L_A(2Ch), OUT_Z_H_A (2Dh)	33
7.12	FIFO_CTRL_REG_A (2Eh)	33
7.13	FIFO_SRC_REG_A (2Fh)	34
7.14	INT1_CFG_A (30h)	34
7.15	INT1_SRC_A (31h)	35
7.16	INT1_THS_A (32h)	36
7.17	INT1_DURATION_A (33h)	36
7.18	CLICK_CFG_A (38h)	36
7.19	CLICK_SRC_A (39h)	37
7.20	CLICK_THS_A (3Ah)	38
7.21	TIME_LIMIT_A (3Bh)	38
7.22	TIME_LATENCY_A (3Ch)	38
7.23	TIME WINDOW_A (3Dh)	38
7.24	CTRL_REG1_G (20h)	39
7.25	CTRL_REG2_G (21h)	40
7.26	CTRL_REG3_G (22h)	41
7.27	CTRL_REG4_G (23h)	41
7.28	CTRL_REG5_G (24h)	42
7.29	REFERENCE/DATACAPTURE_G (25h)	43
7.30	OUT_TEMP_G (26h)	43
7.31	STATUS_REG_G (27h)	44
7.32	OUT_X_L_G (28h), OUT_X_H_G (29h)	44

7.33	OUT_Y_L_G (2Ah), OUT_Y_H_G (2Bh)	44
7.34	OUT_Z_L_G (2Ch), OUT_Z_H_G (2Dh)	44
7.35	FIFO_CTRL_REG_G (2Eh)	45
7.36	FIFO_SRC_REG_G (2Fh)	45
7.37	INT1_CFG_G (30h)	46
7.38	INT1_SRC_G (31h)	47
7.39	INT1_THS_XH_G (32h)	47
7.40	INT1_THS_XL_G (33h)	47
7.41	INT1_THS_YH_G (34h)	48
7.42	INT1_THS_YL_G (35h)	48
7.43	INT1_THS_ZH_G (36h)	48
7.44	INT1_THS_ZL_G (37h)	48
7.45	INT1_DURATION_G (38h)	49
8	Package information	51
9	Revision history	53

List of tables

Table 1.	Device summary	1
Table 2.	Pin description	10
Table 3.	Mechanical characteristics	12
Table 4.	Electrical characteristics	13
Table 5.	Temperature sensor characteristics	13
Table 6.	SPI slave timing values	14
Table 7.	I2C slave timing values	15
Table 8.	Absolute maximum ratings	16
Table 9.	Part list	19
Table 10.	Serial interface pin description	21
Table 11.	Serial interface terminology	21
Table 12.	Transfer when master is writing one byte to slave	22
Table 13.	Transfer when master is writing multiple bytes to slave	22
Table 14.	Transfer when master is receiving (reading) one byte of data from slave	22
Table 15.	Transfer when master is receiving (reading) multiple bytes of data from slave	22
Table 16.	Linear acceleration SAD+Read/Write patterns	23
Table 17.	Angular rate SAD+Read/Write patterns	23
Table 18.	Register address map	27
Table 19.	CTRL_REG1_A register	29
Table 20.	CTRL_REG1_A description	29
Table 21.	Data rate configuration	29
Table 22.	Operating mode selection	30
Table 23.	CTRL_REG2_A register	30
Table 24.	CTRL_REG2_A description	30
Table 25.	High-pass filter mode configuration	30
Table 26.	CTRL_REG3_A register	31
Table 27.	CTRL_REG3_A description	31
Table 28.	CTRL_REG4_A register	31
Table 29.	CTRL_REG4_A description	31
Table 30.	CTRL_REG5_A register	32
Table 31.	CTRL_REG5_A description	32
Table 32.	CTRL_REG6_A register	32
Table 33.	CTRL_REG6 description	32
Table 34.	REFERENCE/DATACAPTURE_A register	32
Table 35.	REFERENCE/DATACAPTURE_A register description	32
Table 36.	STATUS_REG_A register	33
Table 37.	STATUS_REG_A register description	33
Table 38.	FIFO_CTRL_REG_A register	33
Table 39.	FIFO_CTRL_REG_A register description	34
Table 40.	FIFO mode configuration	34
Table 41.	FIFO_SRC_REG_A register	34
Table 42.	INT1_CFG_REG_A register	34
Table 43.	INT1_CFG_REG_A description	34
Table 44.	Interrupt mode	35
Table 45.	INT1_SRC_A register	35
Table 46.	INT1_SRC_A description	35
Table 47.	INT1_THS_A register	36
Table 48.	INT1_THS_A description	36

Table 49.	INT1_DURATION_A register	36
Table 50.	INT1_DURATION_A description	36
Table 51.	CLICK_CFG_A register	36
Table 52.	CLICK_CFG_A description	37
Table 53.	CLICK_SRC_A register	37
Table 54.	CLICK_SRC_A description	37
Table 55.	CLICK_THS_A register	38
Table 56.	CLICK_SRC_A description	38
Table 57.	TIME_LIMIT_A register	38
Table 58.	TIME_LIMIT_A description	38
Table 59.	TIME_LATENCY_A register	38
Table 60.	TIME_LATENCY_A description	38
Table 61.	TIME_WINDOW_A register	38
Table 62.	TIME_WINDOW_A description	38
Table 63.	CTRL_REG1_G register	39
Table 64.	CTRL_REG1_G description	39
Table 65.	DR and BW configuration setting	39
Table 66.	Power mode selection configuration	40
Table 67.	CTRL_REG2_G register	40
Table 68.	CTRL_REG2_G description	40
Table 69.	High-pass filter mode configuration	40
Table 70.	High-pass filter cutoff frequency configuration [Hz]	40
Table 71.	CTRL_REG3_G register	41
Table 72.	CTRL_REG3_G description	41
Table 73.	CTRL_REG4_G register	41
Table 74.	CTRL_REG4_G description	41
Table 75.	CTRL_REG5_G register	42
Table 76.	CTRL_REG5_G description	42
Table 77.	Out_Sel configuration setting	43
Table 78.	INT_SEL configuration setting	43
Table 79.	REFERENCE/DATACAPTURE_G register	43
Table 80.	REFERENCE/DATACAPTURE_G register description	43
Table 81.	OUT_TEMP_G register	43
Table 82.	OUT_TEMP_G register description	44
Table 83.	STATUS_REG_G register	44
Table 84.	STATUS_REG_G description	44
Table 85.	FIFO_CTRL_REG_G register	45
Table 86.	FIFO_CTRL_REG_G register description	45
Table 87.	FIFO mode configuration	45
Table 88.	FIFO_SRC_REG_G register	45
Table 89.	FIFO_SRC_REG_G register description	45
Table 90.	INT1_CFG_G register	46
Table 91.	INT1_CFG_G description	46
Table 92.	INT1_SRC_G register	47
Table 93.	INT1_SRC_G description	47
Table 94.	INT1_THS_XH_G register	47
Table 95.	INT1_THS_XH_G description	47
Table 96.	INT1_THS_XL_G register	47
Table 97.	INT1_THS_XL_G description	47
Table 98.	INT1_THS_YH_G register	48
Table 99.	INT1_THS_YH_G description	48
Table 100.	INT1_THS_YL_G register	48

Table 101.	INT1_THS_YL_G description	48
Table 102.	INT1_THS_ZH_G register	48
Table 103.	INT1_THS_ZH_G description	48
Table 104.	INT1_THS_ZL_G register	48
Table 105.	INT1_THS_ZL_G description	48
Table 106.	INT1_DURATION_G register	49
Table 107.	INT1_DURATION_G description	49
Table 108.	LLGA 7.5 x 4.4 x 1.1 28L mechanical data	52
Table 109.	Document revision history	53

List of figures

Figure 1.	Block diagram	9
Figure 2.	Pin connections	10
Figure 3.	SPI slave timing diagram (2).	14
Figure 4.	I2C slave timing diagram (3).	15
Figure 5.	LSM330DL electrical connections	19
Figure 6.	Read and write protocol	24
Figure 7.	SPI read protocol	25
Figure 8.	Multiple bytes SPI read protocol (2 bytes example)	25
Figure 9.	SPI write protocol	25
Figure 10.	Multiple bytes SPI write protocol (2 bytes example)	26
Figure 11.	SPI read protocol in 3-wire mode	26
Figure 12.	INT1_Sel and Out_Sel configuration block diagram	42
Figure 13.	Wait disabled	49
Figure 14.	Wait enabled	50
Figure 15.	LLGA 7.5 x 4.4 x 1.1 28L package drawing	52

1 Block diagram and pin description

1.1 Block diagram

Figure 1. Block diagram

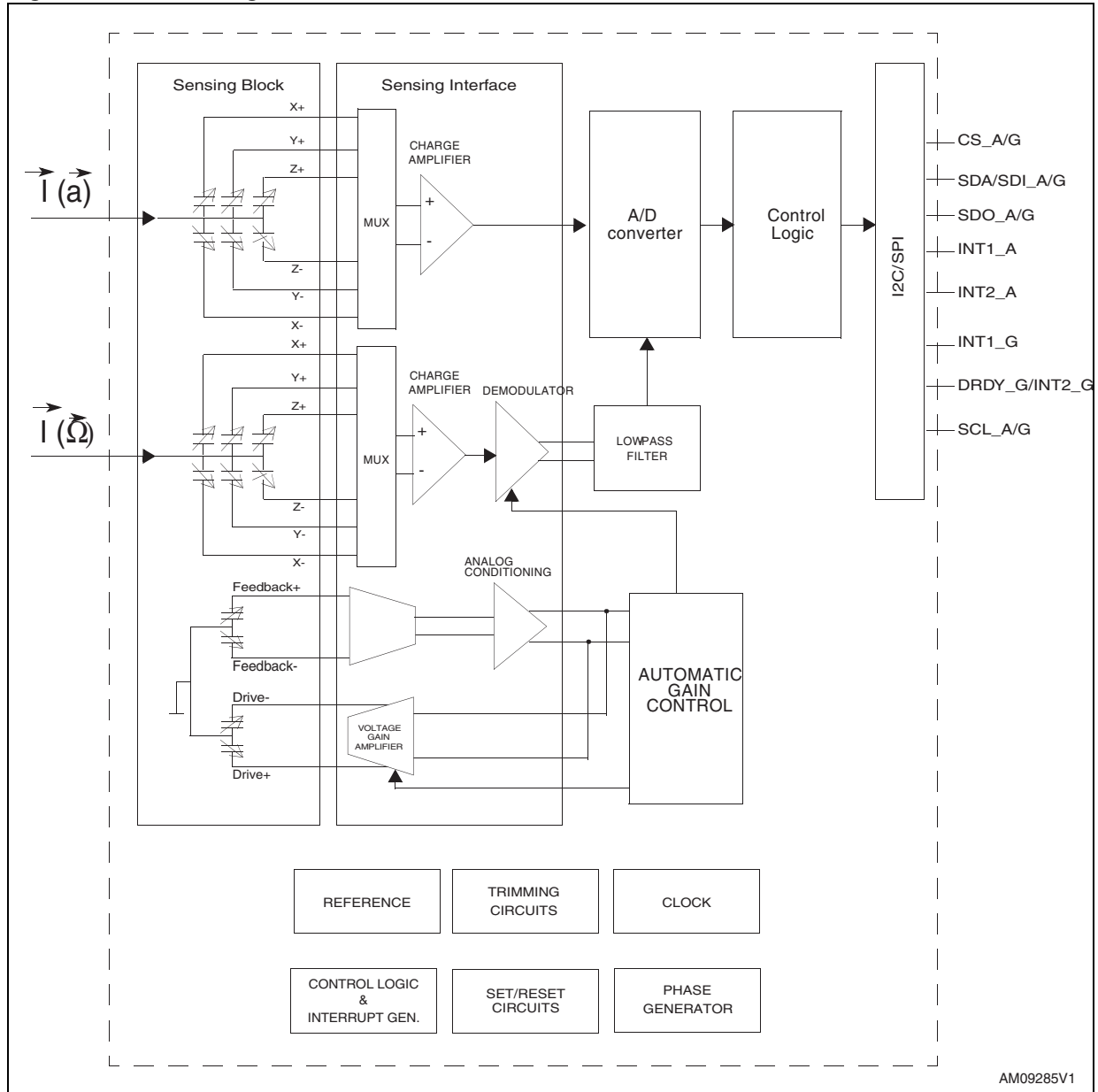

1.2 Pin description

Figure 2. Pin connections

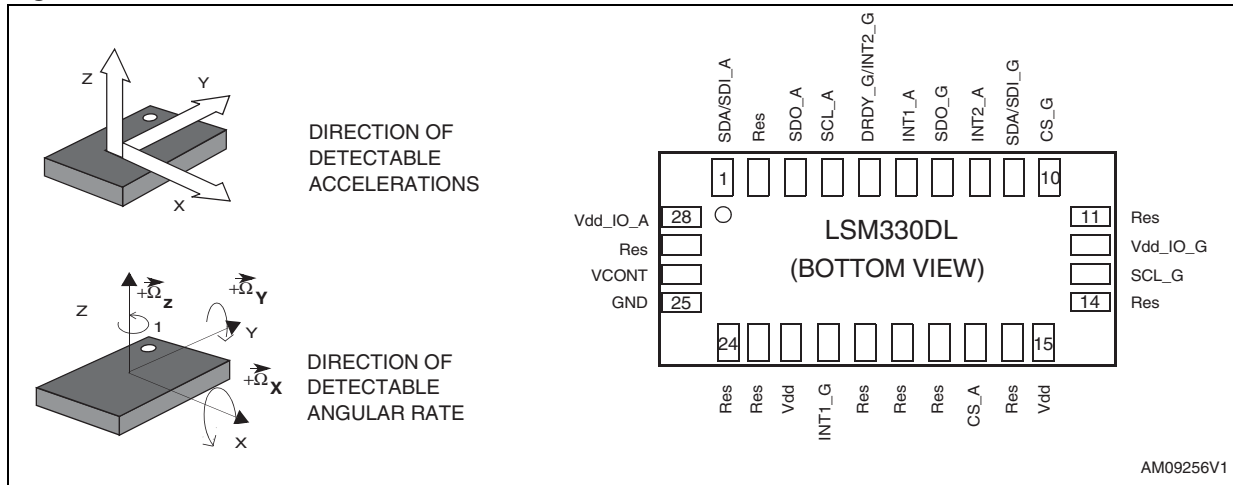

Table 2. Pin description

Pin#	Name	Function
1	SDA/SDI_A	Accelerometer: I ² C serial data (SDA) SPI serial data input (SDI) 3-wire interface serial data output (SDO)
2	Res	Reserved, connect to GND
3	SDO_A	Accelerometer: SPI serial data output (SDO) I ² C least significant bit of the device address (SA0)
4	SCL_A	Accelerometer: I ² C serial clock (SCL) SPI serial port clock (SPC)
5	DRDY_G/INT2_G	Gyroscope data ready/interrupt signal 2
6	INT1_A	Accelerometer interrupt signal
7	SDO_G	Gyroscope: SPI serial data output (SDO) I ² C least significant bit of the device address (SA0)
8	INT2_A	Accelerometer interrupt signal
9	SDA/SDI_G	Gyroscope: I ² C serial data (SDA) SPI serial data input (SDI) 3-wire interface serial data output (SDO)

Table 2. Pin description (continued)

Pin#	Name	Function
10	CS_G	Gyroscope: SPI enable I ² C/SPI mode selection (1: SPI idle mode / I ² C communication enabled; 0: SPI communication mode / I ² C disabled)
11	Res	Reserved, connect to GND
12	Vdd_IO_G	Gyroscope power supply for I/O pins
13	SCL_G	Gyroscope: I ² C serial clock (SCL) SPI serial port clock (SPC)
14	Res	Reserved connect to GND
15	Vdd	Power supply
16	Res	Reserved, connect to GND
17	CS_A	Accelerometer: SPI enable I ² C/SPI mode selection (1: SPI idle mode / I ² C communication enabled; 0: SPI communication mode / I ² C disabled)
18	Res	Reserved, connect to GND
19	Res	Reserved, connect to GND
20	Res	Reserved, connect to GND
21	INT1_G	Gyroscope interrupt signal 1
22	Vdd	Power supply
23	Res	Reserved, connect to GND
24	Res	Reserved, connect to GND
25	GND	0 V power supply
26	VCONT	PLL filter connection
27	Res	Reserved, connect to GND
28	Vdd_IO_A	Accelerometer power supply for I/O pins

2 Module specifications

2.1 Mechanical characteristics

The values given in the following table are for the conditions Vdd = 3 V, T = 25 °C unless otherwise noted.^(a)

Table 3. Mechanical characteristics

Symbol	Parameter	Test conditions	Min.	Typ. ⁽¹⁾	Max.	Unit
LA_FS	Linear acceleration measurement range ⁽²⁾	FS bit set to 00		±2		g
		FS bit set to 01		±4		
		FS bit set to 10		±8		
		FS bit set to 11		±16		
G_FS	Angular rate measurement range ⁽²⁾	FS bit set to 00		±250		dps
		FS bit set to 01		±500		
		FS bit set to 10		±2000		
LA_So	Linear acceleration sensitivity	FS bit set to 00		1		mg/digit
		FS bit set to 01		2		
		FS bit set to 10		4		
		FS bit set to 11		12		
G_So	Angular rate sensitivity	FS bit set to 00		8.75		mdps/digit
		FS bit set to 01		17.5		
		FS bit set to 10		70		
LA_So	Linear acceleration Sensitivity change vs. temperature	FS bit set to 00		±0.05		%/°C
G_So	Angular rate sensitivity change vs. temp.	from -40 to +85°C		±2		%
LA_TyOff	Typical zero-g level offset accuracy ⁽³⁾	FS bit set to 00		±60		mg
G_TyOff	Typical zero-rate level ⁽⁴⁾	FS bit set to 00		10		LSb
LA_TCOff	Zero-g level change vs. temperature	Max delta from 25 °C		±0.5		mg/°C
G_TCOff	Zero-rate level change vs. temperature	FS bit set to 00 from -40 to +85°C		±0.03		dps/°C
An	Acceleration noise density	FS bit set to 00, normal mode, ODR bit set to 1001		220		µg/√Hz
Rn	Rate noise density	FS bit set to 00, BW = 50 Hz		0.03		dps/√Hz
Top	Operating temperature range		-40		+85	°C

1. Typical specifications are not guaranteed.
2. Verified by wafer level test and measurement of initial offset and sensitivity.
3. Typical zero-g level offset value after MSL3 preconditioning.
4. Offset can be eliminated by enabling the built-in high-pass filter.

a. The product is factory calibrated at 3 V. The operational power supply range is from 2.4 V to 3.6 V.

2.2 Electrical characteristics

The values given in the following table are for the conditions $V_{dd} = 3\text{ V}$, $T = 25\text{ °C}$ unless otherwise noted.

Table 4. Electrical characteristics

Symbol	Parameter	Test conditions	Min.	Typ. ⁽¹⁾	Max.	Unit
Vdd	Supply voltage		2.4		3.6	V
Vdd_IO	Power supply for I/O		1.71		Vdd+0.1	V
LA_Idd	LA current consumption in normal mode	ODR = 50 Hz		11		μA
		ODR = 1 Hz		2		
LA_IddLowP	LA current consumption in low-power mode	ODR = 50 Hz		6		μA
LA_IddPdn	LA current consumption in power-down mode	T = 25 °C		0.5		μA
G_Idd	AR current consumption in normal mode			6.1		mA
G_IddLowP	AR supply current in sleep mode ⁽²⁾			1.5		mA
G_IddPdn	AR current consumption in power-down mode	T = 25 °C		5		μA
VIH	Digital high-level input voltage		0.8*Vdd_IO			V
VIL	Digital low-level input voltage				0.2*Vdd_IO	V
VOH	High-level output voltage		0.9*Vdd_IO			V
VOL	Low-level output voltage				0.1*Vdd_IO	V
Top	Operating temperature range		-40		+85	°C

1. Typical specifications are not guaranteed.
2. Sleep mode introduces a faster turn-on time compared to power-down mode.

2.3 Temperature sensor characteristics

The values given in the following table are for the conditions $V_{dd} = 3.0\text{ V}$, $T=25\text{ °C}$, unless otherwise noted.

Table 5. Temperature sensor characteristics ⁽¹⁾

Symbol	Parameter	Test condition	Min.	Typ. ⁽²⁾	Max.	Unit
TSDr	Temperature sensor output change vs. temperature	-		-1		°C/digit
TODR	Temperature refresh rate			1		Hz
Top	Operating temperature range		-40		+85	°C

1. The product is factory calibrated at 3.0 V.
2. Typical specifications are not guaranteed.

2.4 Communication interface characteristics

2.4.1 SPI - serial peripheral interface

The values given in the following table are subject to the general operating conditions for V_{DD} and T_{OP}

Table 6. SPI slave timing values

Symbol	Parameter	Value ⁽¹⁾		Unit
		Min	Max	
t _{c(SPC)}	SPI clock cycle	100		ns
f _{c(SPC)}	SPI clock frequency		10	MHz
t _{su(CS)}	CS setup time	6		ns
t _{h(CS)}	CS hold time	8		
t _{su(SI)}	SDI input setup time	5		
t _{h(SI)}	SDI input hold time	15		
t _{v(SO)}	SDO valid output time		50	
t _{h(SO)}	SDO output hold time	9		
t _{dis(SO)}	SDO output disable time		50	

1. Values are guaranteed at 10 MHz clock frequency for SPI with both 4 and 3 wires, based on characterization results, not tested in production.

Figure 3. SPI slave timing diagram (b)

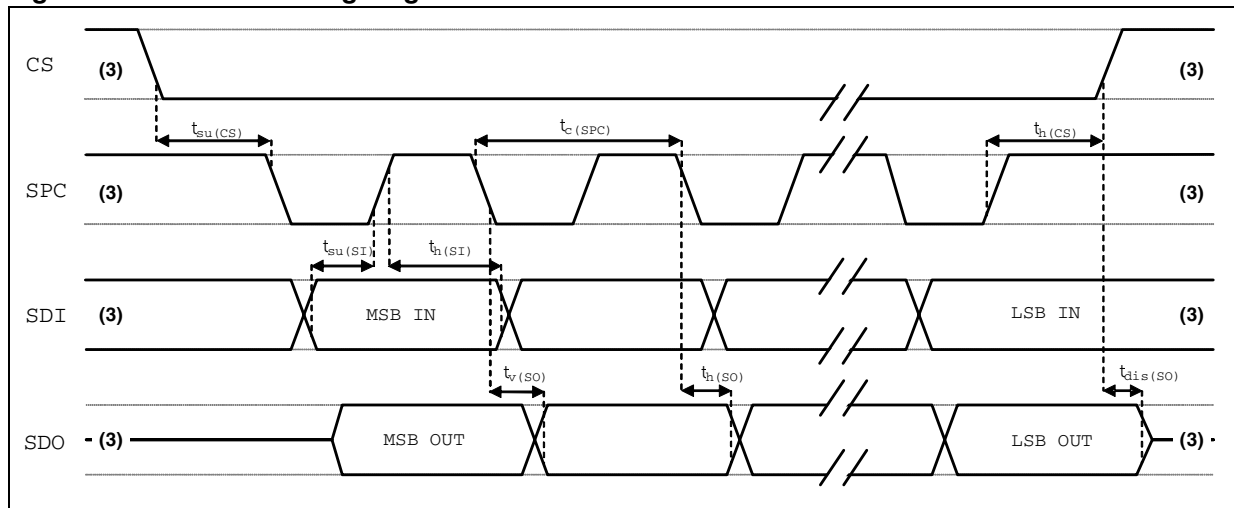

3. Data on CS, SPC, SDI and SDO concern the following pins: CS_A/G, SCL_A/G, SDA/SDI_A/G, SDO_A/G

b. Measurement points are done at 0.2·V_{DD_IO} and 0.8·V_{DD_IO}, for both input and output ports.

2.4.2 I²C - inter-IC control interface

The values given in the following table are subject to the general operating conditions for V_{DD} and T_{OP}

Table 7. I²C slave timing values

Symbol	Parameter ⁽¹⁾	I ² C standard mode		I ² C fast mode ⁽¹⁾		Unit
		Min	Max	Min	Max	
f _(SCL)	SCL clock frequency	0	100	0	400	kHz
t _{w(SCLL)}	SCL clock low time	4.7		1.3		μs
t _{w(SCLH)}	SCL clock high time	4.0		0.6		
t _{su(SDA)}	SDA setup time	250		100		ns
t _{h(SDA)}	SDA data hold time	0.01	3.45	0	0.9	μs
t _{r(SDA)} t _{r(SCL)}	SDA and SCL rise time		1000	20 + 0.1C _b ⁽²⁾	300	ns
t _{f(SDA)} t _{f(SCL)}	SDA and SCL fall time		300	20 + 0.1C _b ⁽²⁾	300	
t _{h(ST)}	START condition hold time	4		0.6		μs
t _{su(SR)}	Repeated START condition setup time	4.7		0.6		
t _{su(SP)}	STOP condition setup time	4		0.6		
t _{w(SP:SR)}	Bus free time between STOP and START condition	4.7		1.3		

1. SCL (SCL_A/G pin), SDA (SDA_A/G pin)

Figure 4. I²C slave timing diagram ⁽³⁾

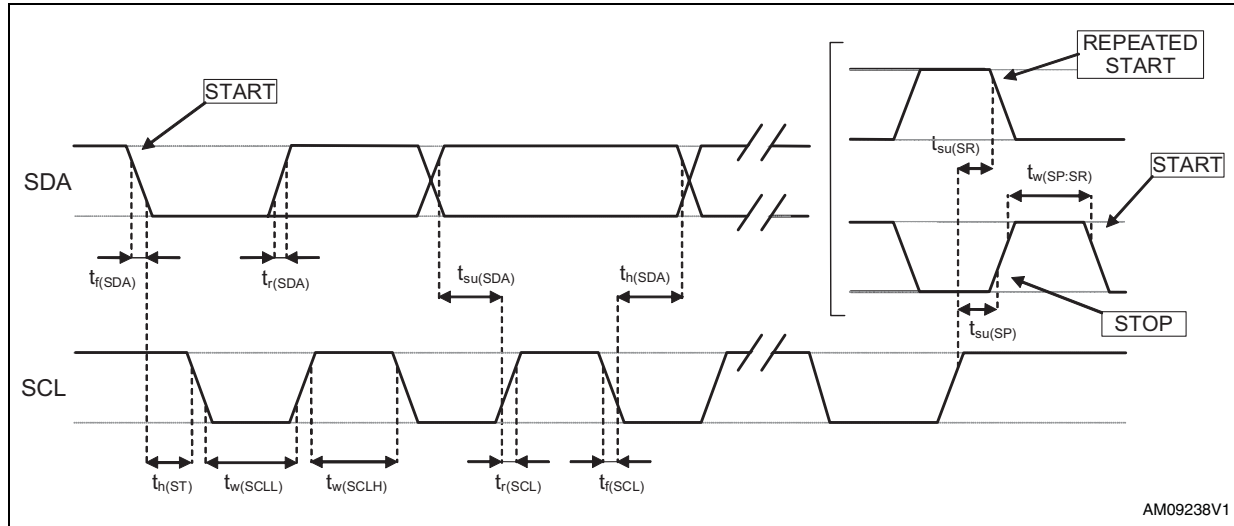

1. Data based on standard I²C protocol requirement, not tested in production.
- 2 C_b = total capacitance of one bus line, in pF
3. Measurement points are done at 0.2·V_{DD_IO} and 0.8·V_{DD_IO}, for both ports.

2.5 Absolute maximum ratings

Stresses above those listed as “absolute maximum ratings” may cause permanent damage to the device. This is a stress rating only and functional operation of the device under these conditions is not implied. Exposure to maximum rating conditions for extended periods may affect device reliability.

Table 8. Absolute maximum ratings

Symbol	Ratings	Maximum value	Unit
Vdd	Supply voltage	-0.3 to 4.8	V
Vdd_IO	I/O pins supply voltage	-0.3 to 4.8	V
Vin	Input voltage on any control pin (SCL_A/G, SDA/SDI_A/G, SDO_A/G, CS_A/G)	-0.3 to Vdd_IO +0.3	V
A _{POW}	Acceleration (any axis, powered, Vdd = 3 V)	3000 g for 0.5 ms	
		10000 g for 0.1 ms	
A _{UNP}	Acceleration (any axis, unpowered)	3000 g for 0.5 ms	
		10000 g for 0.1 ms	
T _{OP}	Operating temperature range	-40 to +85	°C
T _{STG}	Storage temperature range	-40 to +125	°C
ESD	Electrostatic discharge protection	2 (HBM)	kV

Note: Supply voltage on any pin should never exceed 4.8 V



This is a device sensitive to mechanical shock, improper handling can cause permanent damage to the part



This is an ESD-sensitive device, improper handling can cause permanent damage to the part

2.6 Terminology

2.6.1 Sensitivity

Linear acceleration sensitivity can be determined by applying 1 *g* acceleration to the device. As the sensor can measure DC accelerations, this can be done easily by pointing the axis of interest towards the center of the Earth, noting the output value, rotating the sensor by 180 degrees (point to the sky) and then noting the output value again. By doing so, ± 1 *g* acceleration is applied to the sensor. Subtracting the larger output value from the smaller one, and dividing the result by 2, leads to the actual sensitivity of the sensor. This value changes very little over temperature and also very little over time. The sensitivity tolerance describes the range of sensitivities of a large population of sensors.

Angular rate sensitivity describes the angular rate gain of the sensor and can be determined by applying a defined angular velocity to it. This value changes very little over temperature and also very little over time.

2.6.2 Zero level

Linear acceleration zero-*g* level offset (TyOff) describes the deviation of an actual output signal from the ideal output signal if no acceleration is present. A sensor in a steady state on a horizontal surface will measure 0 *g* on the X-axis and 0 *g* on the Y-axis whereas the Z-axis will measure 1 *g*. The output is ideally in the middle of the dynamic range of the sensor (content of OUT registers 00h, data expressed as 2's complement number). A deviation from the ideal value in this case is called zero-*g* offset. Offset is to some extent a result of stress to the MEMS sensor and therefore the offset can slightly change after mounting the sensor onto a printed circuit board or exposing it to extensive mechanical stress. Offset changes little over temperature, see "Zero-*g* level change vs. temperature" (refer to [Table 3](#)). The zero-*g* level tolerance (TyOff) describes the standard deviation of the range of zero-*g* levels of a population of sensors.

The angular rate zero-rate level describes the actual output value if there is no angular rate present. Zero-rate level of precise MEMS sensors is, to some extent, a result of stress to the sensor and therefore the zero-rate level can slightly change after mounting the sensor onto a printed circuit board or after exposing it to extensive mechanical stress. This value changes very little over temperature and also very little over time.

3 Functionality

The LSM330DL is a system-in-package featuring a 3D digital accelerometer and a 3D digital gyroscope.

The complete device includes specific sensing elements and two IC interfaces able to measure both the acceleration and angular rate applied to the module and to provide a signal to the external world through an SPI/I²C serial interface.

The various sensing elements are manufactured using specialized micromachining processes, while the IC interfaces are based on CMOS technology that allows designing a dedicated circuit which is trimmed to better match the sensing element characteristics.

The LSM330DL may also be configured to generate an inertial wake-up and free-fall interrupt signal according to a programmed acceleration event along the enabled axes.

3.1 Factory calibration

The IC interface is factory calibrated for sensitivity and zero level. The trimming values are stored inside the device in non-volatile memory. Any time the device is turned on, the trimming parameters are downloaded into the registers to be used during normal operation. This allows using the device without further calibration.

4 Application hints

Figure 5. LSM330DL electrical connections

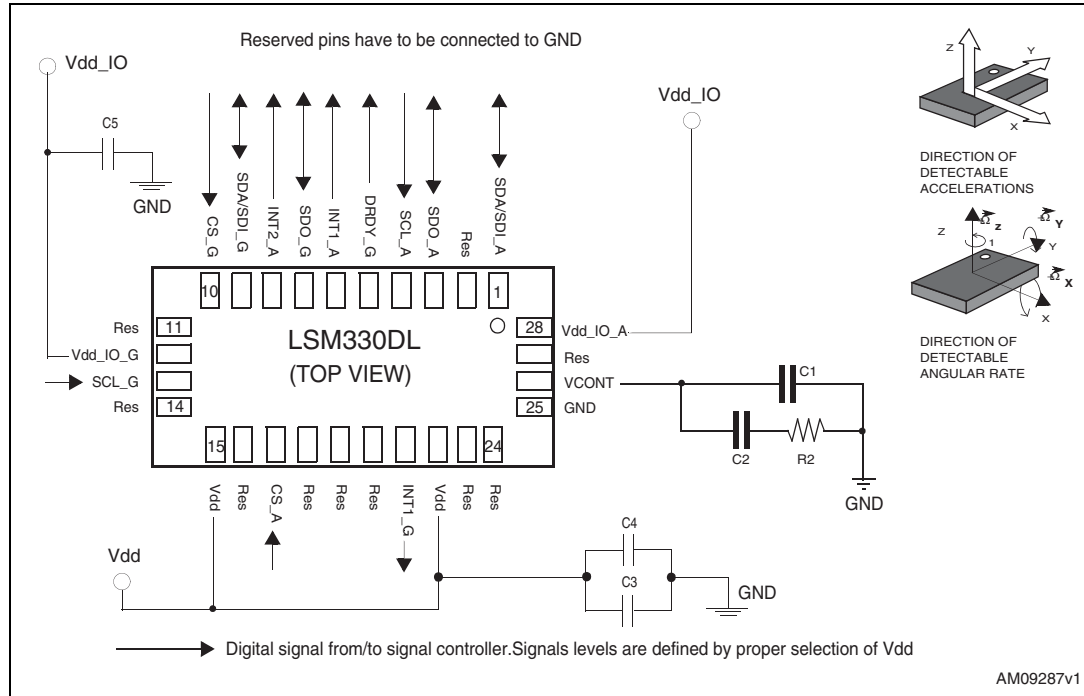

Table 9. Part list

Component	Typical value
C1	10 nF
C2	470 nF
C3	10 μ F
C4	100 nF
C5	
R2	10 kOhm

4.1 External capacitors

The device core is supplied through the Vdd line. Power supply decoupling capacitors (C4=100 nF ceramic, C3=10 μ F Al) should be placed as near as possible to the supply pin of the device (common design practice).

All the voltage and ground supplies must be present at the same time to have proper behavior of the IC (refer to [Figure 5](#)).

The functionality of the device and the measured acceleration/angular rate data is selectable and accessible through the SPI/I²C interface.

The functions, the threshold and the timing of the two interrupt pins for each sensor can be completely programmed by the user through the SPI/I²C interface.

4.2 Soldering information

The LGA package is compliant with the ECOPACK[®], RoHS and “Green” standards. It is qualified for soldering heat resistance according to JEDEC J-STD-020D.

Leave “Pin 1 Indicator” unconnected during soldering.

The landing pattern and soldering recommendations are available at www.st.com/mems.

5 Digital interfaces

The registers embedded inside the LSM330DL may be accessed through both the I²C and SPI serial interfaces. The latter may be SW configured to operate either in 3-wire or 4-wire interface mode.

To select/exploit the I²C interface, the CS line must be tied high (i.e. connected to Vdd_IO).

Table 10. Serial interface pin description

Pin name	Pin description
CS_A	Linear acceleration SPI enable Linear acceleration I ² C/SPI mode selection (1: I ² C mode; 0: SPI enabled)
CS_G	Angular rate SPI enable Angular rate I ² C/SPI mode selection (1: I ² C mode; 0: SPI enabled)
SCL_A SCL_G	I ² C serial clock (SCL) SPI serial port clock (SPC)
SDA/SDI_A SDA/SDI_G	I ² C serial data (SDA) SPI serial data input (SDI) 3-wire interface serial data output (SDO)
SDO_A SDO_G	I ² C least significant bit of the device address (SA0) SPI serial data output (SDO)

5.1 I²C serial interface

The LSM330DL I²C is a bus slave. The I²C is employed to write data into the registers whose content can also be read back.

The relevant I²C terminology is given in the table below.

Table 11. Serial interface terminology

Term	Description
Transmitter	The device which sends data to the bus
Receiver	The device which receives data from the bus
Master	The device which initiates a transfer, generates clock signals and terminates a transfer
Slave	The device addressed by the master

There are two signals associated with the I²C bus: the serial clock line (SCL) and the serial data line (SDA). The latter is a bidirectional line used for sending and receiving the data to/from the interface.

5.1.1 I²C operation

The transaction on the bus is started through a START (ST) signal. A START condition is defined as a HIGH to LOW transition on the data line while the SCL line is held HIGH. After this has been transmitted by the Master, the bus is considered busy. The next byte of data transmitted after the start condition contains the address of the slave in the first 7 bits and the eighth bit tells whether the Master is receiving data from the slave or transmitting data to the slave. When an address is sent, each device in the system compares the first seven bits after a start condition with its own address. If they match, the device considers itself addressed by the Master.

Data transfer with acknowledge is mandatory. The transmitter must release the SDA line during the acknowledge pulse. The receiver must then pull the data line LOW so that it remains stable low during the HIGH period of the acknowledge clock pulse. A receiver which has been addressed is obliged to generate an acknowledge after each byte of data received.

The I²C embedded inside the LSM330DL behaves like a slave device and the following protocol must be adhered to. After the start condition (ST) a slave address is sent, once a slave acknowledge (SAK) has been returned, an 8-bit sub-address (SUB) will be transmitted: the 7 LSb represents the actual register address while the MSB enables the address auto increment. If the MSb of the SUB field is '1', the SUB (register address) will be automatically increased to allow multiple data read/writes.

Table 12. Transfer when master is writing one byte to slave

Master	ST	SAD + W		SUB		DATA		SP
Slave			SAK		SAK		SAK	

Table 13. Transfer when master is writing multiple bytes to slave

Master	ST	SAD + W		SUB		DATA		DATA		SP
Slave			SAK		SAK		SAK		SAK	

Table 14. Transfer when master is receiving (reading) one byte of data from slave

Master	ST	SAD + W		SUB		SR	SAD + R			NMAK	SP
Slave			SAK		SAK			SAK	DATA		

Table 15. Transfer when master is receiving (reading) multiple bytes of data from slave

Master	ST	SAD+W		SUB		SR	SAD+R		MAK		MAK		NMAK	SP
Slave			SAK		SAK			SAK	DATA		DATA		DATA	

Data are transmitted in byte format (DATA). Each data transfer contains 8 bits. The number of bytes transferred per transfer is unlimited. Data is transferred with the Most Significant bit (MSb) first. If a receiver can't receive another complete byte of data until it has performed some other function, it can hold the clock line, SCL LOW to force the transmitter into a wait

state. Data transfer only continues when the receiver is ready for another byte and releases the data line. If a slave receiver doesn't acknowledge the slave address (i.e. it is not able to receive because it is performing some real-time function), the data line must be left HIGH by the slave. The Master can then abort the transfer. A LOW to HIGH transition on the SDA line while the SCL line is HIGH is defined as a STOP condition. Each data transfer must be terminated by the generation of a STOP (SP) condition.

In order to read multiple bytes, it is necessary to assert the most significant bit of the sub-address field. In other words, SUB(7) must be equal to 1 while SUB(6-0) represents the address of first register to be read.

In the presented communication format MAK is Master acknowledge and NMAK is No Master Acknowledge.

Default address

The **SDO/SA0** pad can be used to modify the least significant bit of the device address. If the SA0 pad is connected to a voltage supply, LSb is '1' (ex. address 0011001b), else if the SA0 pad is connected to ground, the LSb value is '0' (ex address 0011000b).

The slave address is completed with a Read/Write bit. If the bit was '1' (Read), a repeated START (SR) condition will have to be issued after the two sub-address bytes. If the bit is '0' (Write), the Master will transmit to the slave with the direction unchanged. [Table 16](#) and [Table 17](#) explain how the SAD+Read/Write bit pattern is composed, listing all the possible configurations.

Linear acceleration address: the default (factory) 7-bit slave address is 001100xb

Table 16. Linear acceleration SAD+Read/Write patterns

Command	SAD[6:1]	SAD[0] = SA0	R/W	SAD+R/W
Read	001100	0	1	00110001 (31h)
Write	001100	0	0	00110000 (30h)
Read	001100	1	1	00110011 (33h)
Write	001100	1	0	00110010 (32h)

Angular rate sensor: the default (factory) 7-bit slave address is 110100xb

Table 17. Angular rate SAD+Read/Write patterns

Command	SAD[6:1]	SAD[0] = SA0	R/W	SAD+R/W
Read	110100	0	1	11010001 (D1h)
Write	110100	0	0	11010000 (D0h)
Read	110100	1	1	11010011 (D3h)
Write	110100	1	0	11010010 (D2h)

5.2 SPI bus interface

The LSM330DL SPI is a bus slave. The SPI allows to write and read the registers of the device.

The Serial Interface interacts with the outside world with 4 wires: **CS**, **SPC**, **SDI** and **SDO** (SPC, SDI, SDO are common).

Figure 6. Read and write protocol

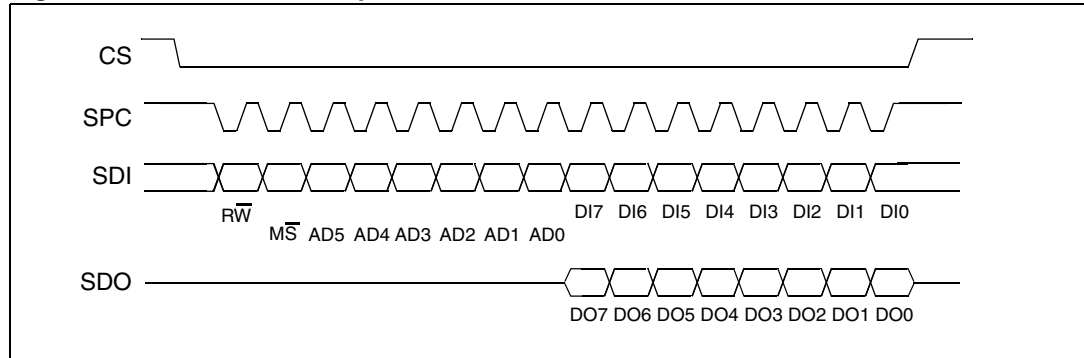

CS is the serial port enable and it is controlled by the SPI master. It goes low at the start of the transmission and goes back high at the end. **SPC** is the serial port clock and it is controlled by the SPI master. It is stopped high when **CS** is high (no transmission). **SDI** and **SDO** are, respectively, the serial port data input and output. These lines are driven at the falling edge of **SPC** and should be captured at the rising edge of **SPC**.

Both the read register and write register commands are completed in 16 clock pulses or in multiples of 8 in case of multiple read/write bytes. Bit duration is the time between two falling edges of **SPC**. The first bit (bit 0) starts at the first falling edge of **SPC** after the falling edge of **CS**, while the last bit (bit 15, bit 23, ...) starts at the last falling edge of **SPC** just before the rising edge of **CS**.

bit 0: $\overline{R\overline{W}}$ bit. When 0, the data $DI(7:0)$ is written into the device. When 1, the data $DO(7:0)$ from the device is read. In the latter case, the chip will drive **SDO** at the start of bit 8.

bit 1: $\overline{M\overline{S}}$ bit. When 0, the address will remain unchanged in multiple read/write commands. When 1, the address will be auto-incremented in multiple read/write commands.

bit 2-7: address $AD(5:0)$. This is the address field of the indexed register.

bit 8-15: data $DI(7:0)$ (write mode). This is the data that will be written into the device (MSb first).

bit 8-15: data $DO(7:0)$ (read mode). This is the data that will be read from the device (MSb first).

In multiple read/write commands, further blocks of 8 clock periods will be added. When the $\overline{M\overline{S}}$ bit is '0', the address used to read/write data remains the same for every block. When the $\overline{M\overline{S}}$ bit is '1', the address used to read/write data is increased at every block.

The function and the behavior of **SDI** and **SDO** remain unchanged.

5.2.1 SPI read

Figure 7. SPI read protocol

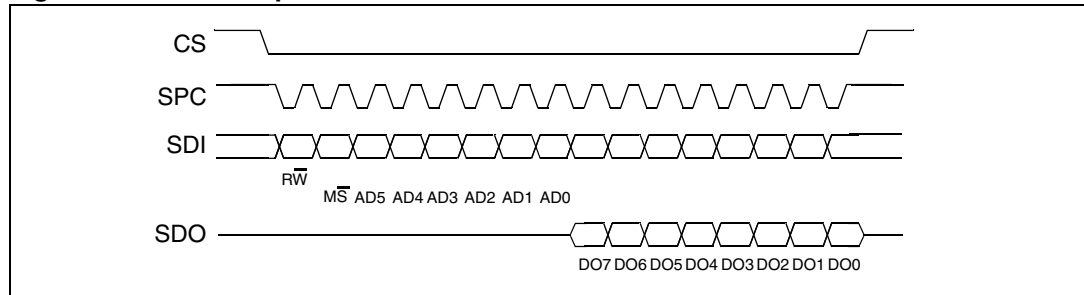

The SPI Read command is performed with 16 clock pulses. The multiple byte read command is performed, adding blocks of 8 clock pulses to the previous one.

bit 0: READ bit. The value is 1.

bit 1: \overline{MS} bit. When 0, this bit does not increment the address. When 1, it increments the address in multiple reads.

bit 2-7: address AD(5:0). This is the address field of the indexed register.

bit 8-15: data DO(7:0) (read mode). This is the data that will be read from the device (MSb first).

bit 16-... : data DO(...-8). Further data in multiple byte reads.

Figure 8. Multiple bytes SPI read protocol (2 bytes example)

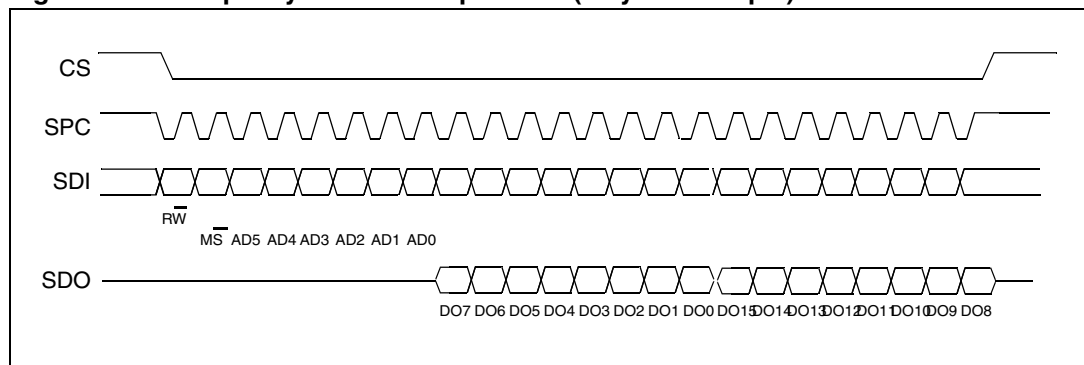

5.2.2 SPI write

Figure 9. SPI write protocol

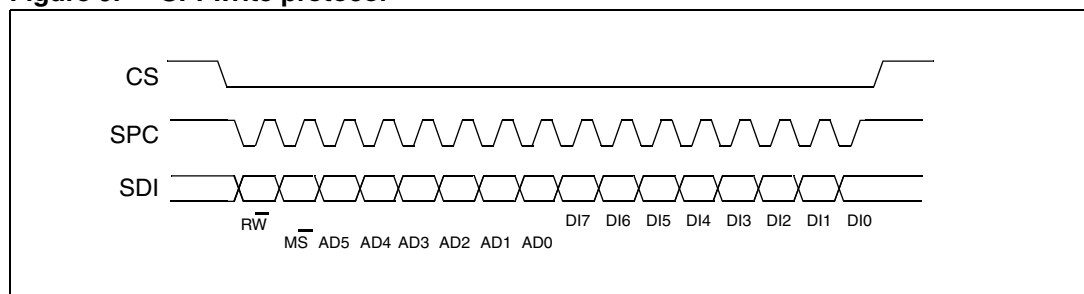

The SPI Write command is performed with 16 clock pulses. The multiple byte write command is performed adding blocks of 8 clock pulses to the previous one.

bit 0: WRITE bit. The value is 0.

bit 1: \overline{MS} bit. When 0, this bit does not increment the address, when 1, it increments the address in multiple writes.

bit 2 -7: address AD(5:0). This is the address field of the indexed register.

bit 8-15: data DI(7:0) (write mode). This is the data that will be written inside the device (MSb first).

bit 16-... : data DI(...-8). Further data in multiple byte writes.

Figure 10. Multiple bytes SPI write protocol (2 bytes example)

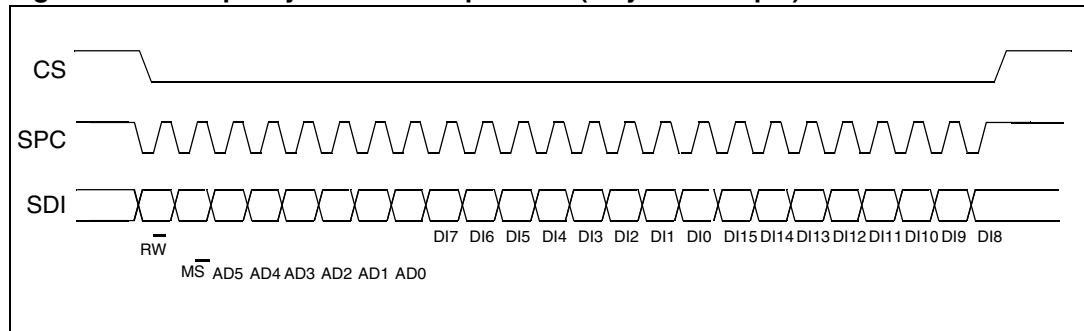

5.2.3 SPI read in 3-wire mode

The 3-wire mode is entered by setting to '1' bit SIM (SPI serial interface mode selection) in CTRL_REG4.

Figure 11. SPI read protocol in 3-wire mode

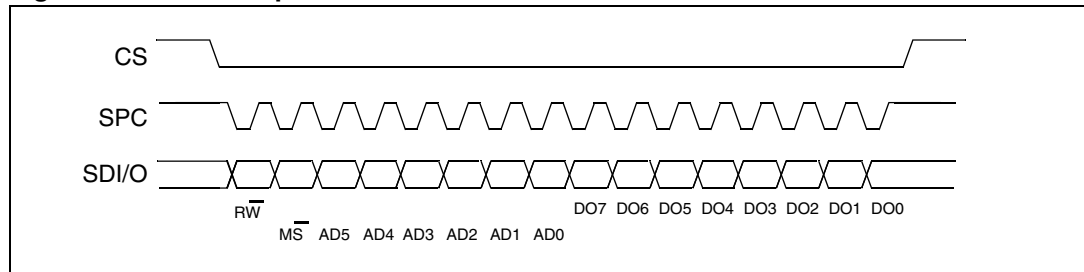

The SPI read command is performed with 16 clock pulses:

bit 0: READ bit. The value is 1.

bit 1: \overline{MS} bit. When 0, this bit does not increment the address, when 1, it increments the address in multiple reads.

bit 2-7: address AD(5:0). This is the address field of the indexed register.

bit 8-15: data DO(7:0) (read mode). This is the data that will be read from the device (MSb first).

The multiple read command is also available in 3-wire mode.

6 Register mapping

The table given below provides a listing of the 8-bit registers embedded in the device and their respective addresses.

Table 18. Register address map

Name	Slave address	Type	Register address		Default	Comment
			Hex	Binary		
Reserved (do not modify)	001100xb		00 - 1F			Reserved
CTRL_REG1_A	001100xb	rw	20	010 0000	00000111	
CTRL_REG2_A	001100xb	rw	21	010 0001	00000000	
CTRL_REG3_A	001100xb	rw	22	010 0010	00000000	
CTRL_REG4_A	001100xb	rw	23	010 0011	00000000	
CTRL_REG5_A	001100xb	rw	24	010 0100	00000000	
CTRL_REG6_A	001100xb	rw	25	010 0101	00000000	
REFERENCE/DATACAPTURE_A	001100xb	rw	26	010 0110	00000000	
STATUS_REG_A	001100xb	r	27	010 0111	00000000	
OUT_X_L_A	001100xb	r	28	010 1000	output	
OUT_X_H_A	001100xb	r	29	010 1001	output	
OUT_Y_L_A	001100xb	r	2A	010 1010	output	
OUT_Y_H_A	001100xb	r	2B	010 1011	output	
OUT_Z_L_A	001100xb	r	2C	010 1100	output	
OUT_Z_H_A	001100xb	r	2D	010 1101	output	
FIFO_CTRL_REG_A	001100xb	rw	2E	010 1110	00000000	
FIFO_SRC_REG_A	001100xb	r	2F	010 1111		
INT1_CFG_A	001100xb	rw	30	011 0000	00000000	
INT1_SRC_A	001100xb	r	31	011 0001	00000000	
INT1_THS_A	001100xb	rw	32	011 0010	00000000	
INT1_DURATION_A	001100xb	rw	33	011 0011	00000000	
INT2_CFG_A	001100xb	rw	34	011 0100	00000000	
INT2_SOURCE_A	001100xb	r	35	011 0101	00000000	
INT2_THS_A	001100xb	rw	36	011 0110	00000000	
INT2_DURATION_A	001100xb	rw	37	011 0111	00000000	
CLICK_CFG_A	001100xb	rw	38	011 1000	00000000	
CLICK_SRC_A	001100xb	rw	39	011 1001	00000000	
CLICK_THS_A	001100xb	rw	3A	011 1010	00000000	
TIME_LIMIT_A	001100xb	rw	3B	011 1011	00000000	

Table 18. Register address map (continued)

Name	Slave address	Type	Register address		Default	Comment
			Hex	Binary		
TIME_LATENCY_A	001100xb	rw	3C	011 1100	00000000	
TIME_WINDOW_A	001100xb	rw	3D	011 1101	00000000	
Reserved (do not modify)	001100xb		3E-3F			Reserved
Reserved	110100xb	-	00-1E	-	-	Reserved
CTRL_REG1_G	110100xb	rw	20	010 0000	00000111	
CTRL_REG2_G	110100xb	rw	21	010 0001	00000000	
CTRL_REG3_G	110100xb	rw	22	010 0010	00000000	
CTRL_REG4_G	110100xb	rw	23	010 0011	00000000	
CTRL_REG5_G	110100xb	rw	24	010 0100	00000000	
REFERENCE/DATACAPTURE_G	110100xb	rw	25	010 0101	00000000	
OUT_TEMP_G	110100xb	r	26	010 0110	output	
STATUS_REG_G	110100xb	r	27	010 0111	output	
OUT_X_L_G	110100xb	r	28	010 1000	output	
OUT_X_H_G	110100xb	r	29	010 1001	output	
OUT_Y_L_G	110100xb	r	2A	010 1010	output	
OUT_Y_H_G	110100xb	r	2B	010 1011	output	
OUT_Z_L_G	110100xb	r	2C	010 1100	output	
OUT_Z_H_G	110100xb	r	2D	010 1101	output	
FIFO_CTRL_REG_G	110100xb	rw	2E	010 1110	00000000	
FIFO_SRC_REG_G	110100xb	r	2F	010 1111	output	
INT1_CFG_G	110100xb	rw	30	011 0000	00000000	
INT1_SRC_G	110100xb	r	31	011 0001	output	
INT1_THS_XH_G	110100xb	rw	32	011 0010	00000000	
INT1_THS_XL_G	110100xb	rw	33	011 0011	00000000	
INT1_THS_YH_G	110100xb	rw	34	011 0100	00000000	
INT1_THS_YL_G	110100xb	rw	35	011 0101	00000000	
INT1_THS_ZH_G	110100xb	rw	36	011 0110	00000000	
INT1_THS_ZL_G	110100xb	rw	37	011 0111	00000000	
INT1_DURATION_G	110100xb	rw	38	011 1000	00000000	

Registers marked as *Reserved* must not be changed. Writing to those registers may cause permanent damage to the device.

The content of the registers that are loaded at boot should not be changed. They contain the factory-calibrated values. Their content is automatically restored when the device is powered up.

7 Registers description

The device contains a set of registers which are used to control its behavior and to retrieve acceleration, angular rate and temperature data. The register addresses, composed of 7 bits, are used to identify them and to write the data through the serial interface.

7.1 CTRL_REG1_A (20h)

Table 19. CTRL_REG1_A register

ODR3	ODR2	ODR1	ODR0	LPen	Zen	Yen	Xen
------	------	------	------	------	-----	-----	-----

Table 20. CTRL_REG1_A description

ODR3-0	Data rate selection. Default value: 0 (0000: power-down; Others: Refer to Table 21: Data rate configuration)
LPen	Low-power mode enable. Default value: 0 (0: normal mode, 1: low-power mode)
Zen	Z-axis enable. Default value: 1 (0: Z-axis disabled; 1: Z-axis enabled)
Yen	Y-axis enable. Default value: 1 (0: Y-axis disabled; 1: Y-axis enabled)
Xen	X-axis enable. Default value: 1 (0: X-axis disabled; 1: X-axis enabled)

ODR<3:0> is used to set power mode and ODR selection. The following table gives the frequency for all combinations of ODR<3:0>.

Table 21. Data rate configuration

ODR3	ODR2	ODR1	ODR0	Power mode selection
0	0	0	0	Power-down mode
0	0	0	1	Normal / low-power mode (1 Hz)
0	0	1	0	Normal / low-power mode (10 Hz)
0	0	1	1	Normal / low-power mode (25 Hz)
0	1	0	0	Normal / low-power mode (50 Hz)
0	1	0	1	Normal / low-power mode (100 Hz)
0	1	1	0	Normal / low-power mode (200 Hz)
0	1	1	1	Normal / low-power mode (400 Hz)
1	0	0	0	Low-power mode (1.620 kHz)
1	0	0	1	Normal (1.344 kHz) / low-power mode (5.376 kHz)

Table 22. Operating mode selection

Operating mode	CTRL_REG1[3] (LPen bit)	CTRL_REG4[3] (HR bit)	BW [Hz]	Turn-on time [ms]
Low-power mode	1	0	ODR/2	1
Normal mode	0	1	ODR/9	7/ODR

7.2 CTRL_REG2_A (21h)

Table 23. CTRL_REG2_A register

HPM1	HPM0	HPCF2	HPCF1	FDS	HPCLICK	HPIS2	HPIS1
------	------	-------	-------	-----	---------	-------	-------

Table 24. CTRL_REG2_A description

HPM1 -HPM0	High-pass filter mode selection. Default value: 00 Refer to Table 25: High-pass filter mode configuration
HPCF2 - HPCF1	High-pass filter cutoff frequency selection
FDS	Filtered data selection. Default value: 0 (0: internal filter bypassed; 1: data from internal filter sent to output register and FIFO)
HPCLICK	High-pass filter enabled for CLICK function (0: filter bypassed; 1: filter enabled)
HPIS2	High-pass filter enabled for AOI function on interrupt 2, (0: filter bypassed; 1: filter enabled)
HPIS1	High-pass filter enabled for AOI function on interrupt 1, (0: filter bypassed; 1: filter enabled)

Table 25. High-pass filter mode configuration

HPM1	HPM0	High-pass filter mode
0	0	Normal mode (reset reading HP_RESET_FILTER)
0	1	Reference signal for filtering
1	0	Normal mode
1	1	Autoreset on interrupt event

7.3 CTRL_REG3_A (22h)

Table 26. CTRL_REG3_A register

I1_CLICK	I1_AOI1	0 ⁽¹⁾	I1_DRDY1	I1_DRDY2	I1_WTM	I1_OVERRUN	--
----------	---------	------------------	----------	----------	--------	------------	----

1. This bit has to be set '0' for correct operation.

Table 27. CTRL_REG3_A description

I1_CLICK	CLICK interrupt on INT1_A. Default value 0. (0: Disable; 1: Enable)
I1_AOI1	AOI1 interrupt on INT1_A. Default value 0. (0: Disable; 1: Enable)
I1_DRDY1	DRDY1 interrupt on INT1_A. Default value 0. (0: Disable; 1: Enable)
I1_DRDY2	DRDY2 interrupt on INT1_A. Default value 0. (0: Disable; 1: Enable)
I1_WTM	FIFO watermark interrupt on INT1_A. Default value 0. (0: Disable; 1: Enable)
I1_OVERRUN	FIFO overrun interrupt on INT1_A. Default value 0. (0: Disable; 1: Enable)

7.4 CTRL_REG4_A (23h)

Table 28. CTRL_REG4_A register

BDU	BLE	FS1	FS0	HR	0 ⁽¹⁾	0 ⁽¹⁾	SIM
-----	-----	-----	-----	----	------------------	------------------	-----

Table 29. CTRL_REG4_A description

BDU	Block data update. Default value: 0(0: continuous update; 1: output registers not updated until MSB and LSB reading)
BLE	Big/little endian data selection. Default value 0. (0: Data LSB at lower address; 1: Data MSB at lower address)
FS1-FS0	Full-scale selection. default value: 00 (00: +/- 2G; 01: +/- 4G; 10: +/- 8G; 11: +/- 16G)
HR	Normal mode: default value: 0 (0: normal mode disable; 1: normal mode enable)
SIM	SPI serial interface mode selection. Default value: 0 (0: 4-wire interface; 1: 3-wire interface)

7.5 CTRL_REG5_A (24h)

Table 30. CTRL_REG5_A register

BOOT	FIFO_EN	--	--	LIR_INT1	D4D_INT1	0 ⁽¹⁾	0 ⁽¹⁾
------	---------	----	----	----------	----------	------------------	------------------

1. This bit has to be set '0' for correct operation.

Table 31. CTRL_REG5_A description

BOOT	Reboot memory content. Default value: 0 (0: normal mode; 1: reboot memory content)
FIFO_EN	FIFO enable. Default value: 0 (0: FIFO disable; 1: FIFO enable)
LIR_INT1	Latch interrupt request on INT1_SRC_A register, with INT1_SRC_A register cleared by reading INT1_SRC_A itself. Default value: 0. (0: interrupt request not latched; 1: interrupt request latched)
D4D_INT1	4D enable: 4D detection is enabled on INT1_A when 6D bit on INT1_CFG_A is set to 1.

7.6 CTRL_REG6_A (25h)

Table 32. CTRL_REG6_A register

I2_CLICKen	I2_INT1	0 ⁽¹⁾	BOOT_I2	0 ⁽¹⁾	--	H_LACTIVE	--
------------	---------	------------------	---------	------------------	----	-----------	----

1. This bit has to be set to '0' for correct operation.

Table 33. CTRL_REG6 description

I2_CLICKen	Click interrupt on INT2_A. Default value 0.
I2_INT1	Interrupt 1 function enabled on INT2_A. Default 0.
BOOT_I2	Boot on INT2_A.
H_LACTIVE	0: interrupt active high; 1: interrupt active low.

7.7 REFERENCE/DATACAPTURE_A (26h)

Table 34. REFERENCE/DATACAPTURE_A register

Ref7	Ref6	Ref5	Ref4	Ref3	Ref2	Ref1	Ref0
------	------	------	------	------	------	------	------

Table 35. REFERENCE/DATACAPTURE_A register description

Ref 7-Ref0	Reference value for interrupt generation. Default value: 0
------------	--

7.8 STATUS_REG_A (27h)

Table 36. STATUS_REG_A register

ZYXOR	ZOR	YOR	XOR	ZYXDA	ZDA	YDA	XDA
-------	-----	-----	-----	-------	-----	-----	-----

Table 37. STATUS_REG_A register description

ZYXOR	X-, Y- and Z-axis data overwrite. Default value: 0 (0: no overwrite has occurred; 1: a new set of data has overwritten the previous ones)
ZOR	Z-axis data overwrite. Default value: 0 (0: no overrun has occurred; 1: a new data for the Z-axis has overwritten the previous one)
YOR	Y-axis data overwrite. Default value: 0 (0: no overwrite has occurred; 1: new data for the Y-axis has overwritten the previous data)
XOR	X-axis data overwrite. Default value: 0 (0: no overwrite has occurred; 1: new data for the X-axis has overwritten the previous data)
ZYXDA	X-, Y- and Z-axis new data available. Default value: 0 (0: a new set of data is not yet available; 1: a new set of data is available)
ZDA	Z-axis new data available. Default value: 0 (0: new data for the Z-axis is not yet available; 1: new data for the Z-axis is available)
YDA	Y-axis new data available. Default value: 0 (0: new data for the Y-axis is not yet available; 1: new data for the Y-axis is available)

7.9 OUT_X_L_A (28h), OUT_X_H_A (29h)

This register contains X-axis acceleration data. Values are expressed in two's complement.

7.10 OUT_Y_L_A (2Ah), OUT_Y_H_A (2Bh)

This register contains Y-axis acceleration data. Values are expressed in two's complement.

7.11 OUT_Z_L_A(2Ch), OUT_Z_H_A (2Dh)

This register contains Z-axis acceleration data. Values are expressed in two's complement.

7.12 FIFO_CTRL_REG_A (2Eh)

Table 38. FIFO_CTRL_REG_A register

FM1	FM0	TR	FTH4	FTH3	FTH2	FTH1	FTH0
-----	-----	----	------	------	------	------	------

Table 39. FIFO_CTRL_REG_A register description

FM1-FM0	FIFO mode selection. Default value: 00 (see Table 40: FIFO mode configuration)
TR	Trigger selection. Default value: 0 0: Trigger event linked to trigger signal on INT1_A 1: Trigger event linked to trigger signal on INT2_A
FTH4:0	Default value: 0

Table 40. FIFO mode configuration

FM1	FM0	FIFO mode
0	0	Bypass mode
0	1	FIFO mode
1	0	Stream mode
1	1	Trigger mode

7.13 FIFO_SRC_REG_A (2Fh)

Table 41. FIFO_SRC_REG_A register

WTM	OVNR_FIFO	EMPTY	FSS4	FSS3	FSS2	FSS1	FSS0
-----	-----------	-------	------	------	------	------	------

7.14 INT1_CFG_A (30h)

Table 42. INT1_CFG_REG_A register

AOI	6D	ZHIE/ ZUPE	ZLIE/ ZDOWNE	YHIE/ YUPE	YLIE/ YDOWNE	XHIE/ XUPE	XLIE/ XDOWNE
-----	----	---------------	-----------------	---------------	-----------------	---------------	-----------------

Table 43. INT1_CFG_REG_A description

AOI	And/Or combination of Interrupt events. Default value: 0. Refer to Table 44: Interrupt mode
6D	6-direction detection function enabled. Default value: 0. Refer to Table 44: Interrupt mode
ZHIE/ ZUPE	Enable interrupt generation on Z high event or on direction recognition. Default value: 0 (0: disable interrupt request; 1: enable interrupt request)
ZLIE/ ZDOWNE	Enable interrupt generation on Z low event or on direction recognition. Default value: 0 (0: disable interrupt request; 1: enable interrupt request)
YHIE/ YUPE	Enable interrupt generation on Y high event or on direction recognition. Default value: 0 (0: disable interrupt request; 1: enable interrupt request.)
YLIE/ YDOWNE	Enable interrupt generation on Y low event or on direction recognition. Default value: 0 (0: disable interrupt request; 1: enable interrupt request.)

Table 43. INT1_CFG_REG_A description (continued)

XHIE/ XUPE	Enable interrupt generation on X high event or on direction recognition. Default value: 0 (0: disable interrupt request; 1: enable interrupt request.)
XLIE/XDO WNE	Enable interrupt generation on X low event or on direction recognition. Default value: 0 (0: disable interrupt request; 1: enable interrupt request.)

The contents of the INT1_CFG_REG_A register are loaded at boot.

A write operation at this address is possible only after system boot.

Table 44. Interrupt mode

AOI	6D	Interrupt mode
0	0	OR combination of interrupt events
0	1	6-direction movement recognition
1	0	AND combination of interrupt events
1	1	6-direction position recognition

The difference between AOI-6D = '01' and AOI-6D = '11' is defined as follows:

AOI-6D = '01' is movement recognition. An interrupt is generated when the orientation moves from an unknown zone to a known zone. The interrupt signal stays for a duration determined by ODR.

AOI-6D = '11' is direction recognition. An interrupt is generated when the orientation is inside a known zone. The interrupt signal stays until orientation is inside the zone.

7.15 INT1_SRC_A (31h)

Table 45. INT1_SRC_A register

0 ⁽¹⁾	IA	ZH	ZL	YH	YL	XH	XL
------------------	----	----	----	----	----	----	----

1. This bit has to be set to '0' for correct operation.

Table 46. INT1_SRC_A description

IA	Interrupt active. Default value: 0 (0: no interrupt has been generated; 1: one or more interrupts have been generated)
ZH	Z high. Default value: 0 (0: no interrupt, 1: Z high event has occurred)
ZL	Z low. Default value: 0 (0: no interrupt; 1: Z low event has occurred)
YH	Y high. Default value: 0 (0: no interrupt, 1: Y high event has occurred)
YL	Y low. Default value: 0 (0: no interrupt, 1: Y low event has occurred)

Table 46. INT1_SRC_A description

XH	X high. Default value: 0 (0: no interrupt, 1: X high event has occurred)
XL	X low. Default value: 0 (0: no interrupt, 1: X low event has occurred)

The Interrupt 1 source register is a read-only register.

Reading at this address clears the INT1_SRC_A IA bit (and the interrupt signal on the INT1_A pin) and allows the refreshment of data in the INT1_SRC_A register if the latched option was chosen.

7.16 INT1_THS_A (32h)

Table 47. INT1_THS_A register

0 ⁽¹⁾	THS6	THS5	THS4	THS3	THS2	THS1	THS0
------------------	------	------	------	------	------	------	------

1. This bit has to be set to '0' for correct operation.

Table 48. INT1_THS_A description

THS6 - THS0	Interrupt 1 threshold. Default value: 000 0000
-------------	--

7.17 INT1_DURATION_A (33h)

Table 49. INT1_DURATION_A register

0 ⁽¹⁾	D6	D5	D4	D3	D2	D1	D0
------------------	----	----	----	----	----	----	----

1. This bit has to be set to '0' for correct operation.

Table 50. INT1_DURATION_A description

D6 - D0	Duration value. Default value: 000 0000
---------	---

The D6 - D0 bits set the minimum duration of the Interrupt 1 event to be recognized. The duration of the steps and maximum values depend on the ODR chosen.

7.18 CLICK_CFG_A (38h)

Table 51. CLICK_CFG_A register

--	--	ZD	ZS	YD	YS	XD	XS
----	----	----	----	----	----	----	----

Table 52. CLICK_CFG_A description

ZD	Enable interrupt double CLICK on Z-axis. Default value: 0 (0: disable interrupt request; 1: enable interrupt request on measured accel. value higher than preset threshold)
ZS	Enable interrupt single CLICK on Z-axis. Default value: 0 (0: disable interrupt request; 1: enable interrupt request on measured accel. value higher than preset threshold)
YD	Enable interrupt double CLICK on Y-axis. Default value: 0 (0: disable interrupt request; 1: enable interrupt request on measured accel. value higher than preset threshold)
YS	Enable interrupt single CLICK on Y-axis. Default value: 0 (0: disable interrupt request; 1: enable interrupt request on measured accel. value higher than preset threshold)
XD	Enable interrupt double CLICK on X-axis. Default value: 0 (0: disable interrupt request; 1: enable interrupt request on measured accel. value higher than preset threshold)
XS	Enable interrupt single CLICK on X-axis. Default value: 0 (0: disable interrupt request; 1: enable interrupt request on measured accel. value higher than preset threshold)

7.19 CLICK_SRC_A (39h)

Table 53. CLICK_SRC_A register

--	IA	DCLICK	SCLICK	Sign	Z	Y	X
----	----	--------	--------	------	---	---	---

Table 54. CLICK_SRC_A description

IA	Interrupt active. Default value: 0 (0: no interrupt has been generated; 1: one or more interrupts have been generated)
DCLICK	Double CLICK-CLICK enable. Default value: 0 (0: double CLICK-CLICK detection disable, 1: double CLICK-CLICK detection enable)
SCLICK	Single CLICK-CLICK enable. Default value: 0 (0: single CLICK-CLICK detection disable, 1: single CLICK-CLICK detection enable)
Sign	CLICK-CLICK Sign. 0: positive detection, 1: negative detection
Z	Z CLICK-CLICK detection. Default value: 0 (0: no interrupt, 1: Z high event has occurred)
Y	Y CLICK-CLICK detection. Default value: 0 (0: no interrupt, 1: Y high event has occurred)
X	X CLICK-CLICK detection. Default value: 0 (0: no interrupt, 1: X high event has occurred)

7.20 CLICK_THS_A (3Ah)

Table 55. CLICK_THS_A register

LIR	Ths6	Ths5	Ths4	Ths3	Ths2	Ths1	Ths0
-----	------	------	------	------	------	------	------

Table 56. CLICK_SRC_A description

Ths6-Ths0	CLICK-CLICK threshold. Default value: 000 0000
LIR	Latch interrupt request for CLICK-CLICK function enable. 0 disable, 1 enable

7.21 TIME_LIMIT_A (3Bh)

Table 57. TIME_LIMIT_A register

--	TLI6	TLI5	TLI4	TLI3	TLI2	TLI1	TLI0
----	------	------	------	------	------	------	------

Table 58. TIME_LIMIT_A description

TLI7-TLI0	CLICK-CLICK time limit. Default value: 000 0000
-----------	---

7.22 TIME_LATENCY_A (3Ch)

Table 59. TIME_LATENCY_A register

TLA7	TLA6	TLA5	TLA4	TLA3	TLA2	TLA1	TLA0
------	------	------	------	------	------	------	------

Table 60. TIME_LATENCY_A description

TLA7-TLA0	CLICK-CLICK time latency. Default value: 000 0000
-----------	---

7.23 TIME_WINDOW_A (3Dh)

Table 61. TIME_WINDOW_A register

TW7	TW6	TW5	TW4	TW3	TW2	TW1	TW0
-----	-----	-----	-----	-----	-----	-----	-----

Table 62. TIME_WINDOW_A description

TW7-TW0	CLICK-CLICK time window
---------	-------------------------

7.24 CTRL_REG1_G (20h)

Table 63. CTRL_REG1_G register

DR1	DR0	BW1	BW0	PD	Zen	Yen	Xen
-----	-----	-----	-----	----	-----	-----	-----

Table 64. CTRL_REG1_G description

DR1-DR0	Output data rate selection. Refer to Table 65: DR and BW configuration setting
BW1-BW0	Bandwidth selection. Refer to Table 65: DR and BW configuration setting
PD	Power-down mode enable. Default value: 0 (0: power-down mode, 1: normal mode or sleep mode)
Zen	Z-axis enable. Default value: 1 (0: Z-axis disabled; 1: Z-axis enabled)
Yen	Y-axis enable. Default value: 1 (0: Y-axis disabled; 1: Y-axis enabled)
Xen	X-axis enable. Default value: 1 (0: X-axis disabled; 1: X-axis enabled)

DR<1:0> is used to set the ODR selection. **BW <1:0>** is used to set bandwidth selection.

The following table gives the frequencies for all combinations of the DR / BW bits.

Table 65. DR and BW configuration setting

DR <1:0>	BW <1:0>	ODR [Hz]	cutoff [Hz]
00	00	100	12.5
00	01	100	25
00	10	100	25
00	11	100	25
01	00	200	12.5
01	01	200	25
01	10	200	50
01	11	200	70
10	00	400	20
10	01	400	25
10	10	400	50
10	11	400	110
11	00	800	30
11	01	800	35
11	10	800	50
11	11	800	110

Combination of **PD**, **Zen**, **Yen**, **Xen** are used to set device in different modes (power-down / normal / sleep mode) according to the following table.

Table 66. Power mode selection configuration

Mode	PD	Zen	Yen	Xen
Power-down	0	-	-	-
Sleep	1	0	0	0
Normal	1	-	-	-

7.25 CTRL_REG2_G (21h)

Table 67. CTRL_REG2_G register

0 ⁽¹⁾	0 ⁽¹⁾	HPM1	HPM0	HPCF3	HPCF2	HPCF1	HPCF0
------------------	------------------	------	------	-------	-------	-------	-------

1. This bit has to be set to '0' for correct operation.

Table 68. CTRL_REG2_G description

HPM1-HPM0	High-pass filter mode selection. Default value: 00 Refer to Table 69: High-pass filter mode configuration
HPCF3-HPCF0	High-pass filter cutoff frequency selection Refer to Table 70: High-pass filter cutoff frequency configuration [Hz]

Table 69. High-pass filter mode configuration

HPM1	HPM0	High-pass filter mode
0	0	Normal mode (reset reading HP_RESET_FILTER)
0	1	Reference signal for filtering
1	0	Normal mode
1	1	Autoreset on interrupt event

Table 70. High-pass filter cutoff frequency configuration [Hz]

HPCF3-0	ODR = 100 Hz	ODR = 200 Hz	ODR = 400 Hz	ODR = 800 Hz
0000	8	15	30	56
0001	4	8	15	30
0010	2	4	8	15
0011	1	2	4	8
0100	0.5	1	2	4
0101	0.2	0.5	1	2

Table 70. High-pass filter cutoff frequency configuration [Hz] (continued)

HPCF3-0	ODR = 100 Hz	ODR = 200 Hz	ODR = 400 Hz	ODR = 800 Hz
0110	0.1	0.2	0.5	1
0111	0.05	0.1	0.2	0.5
1000	0.02	0.05	0.1	0.2
1001	0.01	0.02	0.05	0.1

7.26 CTRL_REG3_G (22h)

Table 71. CTRL_REG3_G register

I1_Int1	I1_Boot	H_Lactive	PP_OD	I2_DRDY	I2_WTM	I2_ORun	I2_Empty
---------	---------	-----------	-------	---------	--------	---------	----------

Table 72. CTRL_REG3_G description

I1_Int1	Interrupt enable on INT1_G pin. Default value 0. (0: Disable; 1: Enable)
I1_Boot	Boot status available on INT1_G. Default value 0. (0: Disable; 1: Enable)
H_Lactive	Interrupt active configuration on INT1_G. Default value 0. (0: High; 1:Low)
PP_OD	Push-Pull / Open drain. Default value: 0. (0: Push-Pull; 1: Open drain)
I2_DRDY	Date Ready on DRDY_G/INT2_G. Default value 0. (0: Disable; 1: Enable)
I2_WTM	FIFO watermark interrupt on DRDY_G/INT2_G. Default value: 0. (0: Disable; 1: Enable)
I2_ORun	FIFO overrun interrupt on DRDY_G/INT2_G Default value: 0. (0: Disable; 1: Enable)
I2_Empty	FIFO empty interrupt on DRDY_G/INT2_G. Default value: 0. (0: Disable; 1: Enable)

7.27 CTRL_REG4_G (23h)

Table 73. CTRL_REG4_G register

BDU	BLE	FS1	FS0	--	0 ⁽¹⁾	0 ⁽¹⁾	SIM
-----	-----	-----	-----	----	------------------	------------------	-----

1. This bit has to be set to '0' for correct operation.

Table 74. CTRL_REG4_G description

BDU	Block data update. Default value: 0 (0: continuous update; 1: output registers not updated until MSB and LSB have been read)
BLE	Big/little endian data selection. Default value 0. (0: Data LSB at lower address; 1: Data MSB at lower address)

Table 74. CTRL_REG4_G description (continued)

FS1-FS0	Full-scale selection. Default value: 00 (00: 250 dps; 01: 500 dps; 10: 2000 dps; 11: 2000 dps)
SIM	SPI serial interface mode selection. Default value: 0 (0: 4-wire interface; 1: 3-wire interface).

7.28 CTRL_REG5_G (24h)

Table 75. CTRL_REG5_G register

BOOT	FIFO_EN	--	HPen	INT1_Sel1	INT1_Sel0	Out_Sel1	Out_Sel0
------	---------	----	------	-----------	-----------	----------	----------

Table 76. CTRL_REG5_G description

BOOT	Reboot memory content. Default value: 0 (0: normal mode; 1: reboot memory content)
FIFO_EN	FIFO enable. Default value: 0 (0: FIFO disable; 1: FIFO Enable)
HPen	High-pass filter enable. Default value: 0 (0: HPF disabled; 1: HPF enabled See Figure 12: INT1_Sel and Out_Sel configuration block diagram)
INT1_Sel1- INT1_Sel0	INT1 selection configuration. Default value: 0 (See Figure 12: INT1_Sel and Out_Sel configuration block diagram)
Out_Sel1- Out_Sel0	Out selection configuration. Default value: 0 (See Figure 12: INT1_Sel and Out_Sel configuration block diagram)

Figure 12. INT1_Sel and Out_Sel configuration block diagram

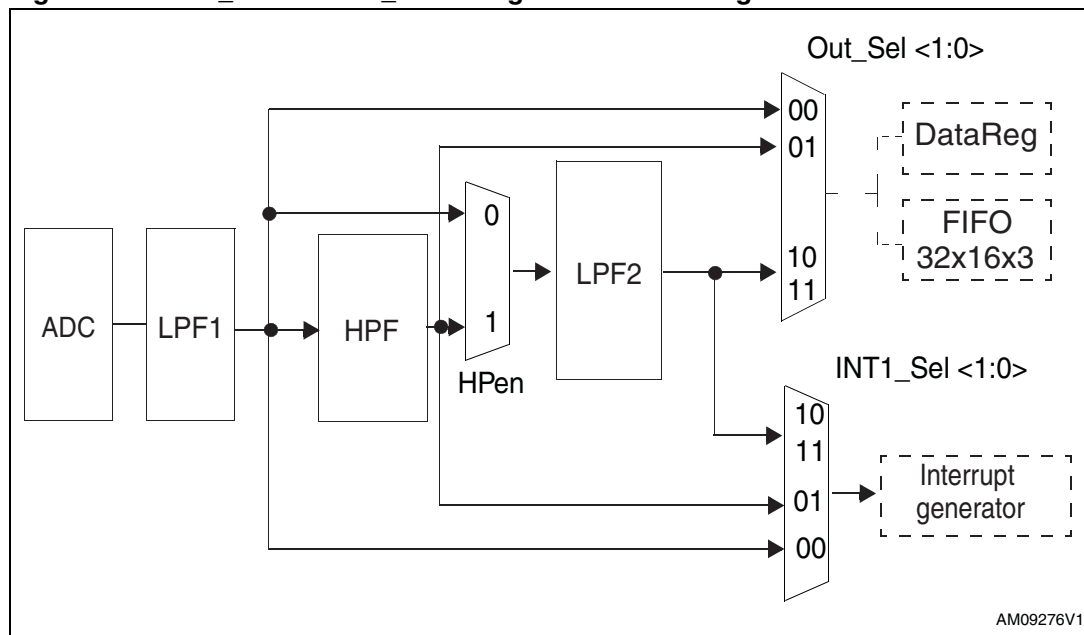

AM09276V1

Table 77. Out_Sel configuration setting

Hpen	OUT_SEL1	OUT_SEL0	Description
x	0	0	Data in DataReg and FIFO are non-high-pass-filtered
x	0	1	Data in DataReg and FIFO are high-pass-filtered
0	1	x	Data in DataReg and FIFO are low-pass-filtered by LPF2
1	1	x	Data in DataReg and FIFO are high-pass and low-pass-filtered by LPF2

Table 78. INT_SEL configuration setting

Hpen	INT_SEL1	INT_SEL2	Description
x	0	0	Non-high-pass-filtered data are used for interrupt generation
x	0	1	High-pass-filtered data are used for interrupt generation
0	1	x	Low-pass-filtered data are used for interrupt generation
1	1	x	High-pass and low-pass-filtered data are used for interrupt generation

7.29 REFERENCE/DATACAPTURE_G (25h)

Table 79. REFERENCE/DATACAPTURE_G register

Ref7	Ref6	Ref5	Ref4	Ref3	Ref2	Ref1	Ref0
------	------	------	------	------	------	------	------

Table 80. REFERENCE/DATACAPTURE_G register description

Ref 7-Ref0	Reference value for interrupt generation. Default value: 0
------------	--

7.30 OUT_TEMP_G (26h)

Table 81. OUT_TEMP_G register

Temp7	Temp6	Temp5	Temp4	Temp3	Temp2	Temp1	Temp0
-------	-------	-------	-------	-------	-------	-------	-------

Table 82. OUT_TEMP_G register description

Temp7-Temp0	Temperature data (1LSB/deg - 8-bit resolution). The value is expressed as two's complement.
-------------	---

7.31 STATUS_REG_G (27h)

Table 83. STATUS_REG_G register

ZYXOR	ZOR	YOR	XOR	ZYXDA	ZDA	YDA	XDA
-------	-----	-----	-----	-------	-----	-----	-----

Table 84. STATUS_REG_G description

ZYXOR	X-, Y-, Z-axis data overwrite. Default value: 0 (0: no overwrite has occurred; 1: new data has overwritten the previous data before it was read)
ZOR	Z-axis data overwrite. Default value: 0 (0: no overwrite has occurred; 1: new data for the Z-axis has overwritten the previous data)
YOR	Y-axis data overwrite. Default value: 0 (0: no overwrite has occurred; 1: new data for the Y-axis has overwritten the previous data)
XOR	X-axis data overwrite. Default value: 0 (0: no overwrite has occurred; 1: new data for the X-axis has overwritten the previous data)
ZYXDA	X-, Y-, Z-axis new data available. Default value: 0 (0: a new set of data is not yet available; 1: a new set of data is available)
ZDA	Z-axis new data available. Default value: 0 (0: new data for the Z-axis is not yet available; 1: new data for the Z-axis is available)
YDA	Y-axis new data available. Default value: 0 (0: new data for the Y-axis is not yet available; 1: new data for the Y-axis is available)
XDA	X-axis new data available. Default value: 0 (0: new data for the X-axis is not yet available; 1: new data for the X-axis is available)

7.32 OUT_X_L_G (28h), OUT_X_H_G (29h)

This register contains X-axis angular rate data. Values are expressed as two's complement.

7.33 OUT_Y_L_G (2Ah), OUT_Y_H_G (2Bh)

This register contains Y-axis angular rate data. Values are expressed as two's complement.

7.34 OUT_Z_L_G (2Ch), OUT_Z_H_G (2Dh)

This register contains Z-axis angular rate data. Values are expressed as two's complement.

7.35 FIFO_CTRL_REG_G (2Eh)

Table 85. FIFO_CTRL_REG_G register

FM2	FM1	FM0	WTM4	WTM3	WTM2	WTM1	WTM0
-----	-----	-----	------	------	------	------	------

Table 86. FIFO_CTRL_REG_G register description

FM2-FM0	FIFO mode selection. Default value: 00 (see Table 40: FIFO mode configuration)
WTM4-WTM0	FIFO threshold. Watermark level setting

Table 87. FIFO mode configuration

FM2	FM1	FM0	FIFO mode
0	0	0	Bypass mode
0	0	1	FIFO mode
0	1	0	Stream mode
0	1	1	Stream-to-FIFO mode
1	0	0	Bypass-to-Stream mode

7.36 FIFO_SRC_REG_G (2Fh)

Table 88. FIFO_SRC_REG_G register

WTM	OVRN	EMPTY	FSS4	FSS3	FSS2	FSS1	FSS0
-----	------	-------	------	------	------	------	------

Table 89. FIFO_SRC_REG_G register description

WTM	Watermark status. (0: FIFO filling is lower than WTM level; 1: FIFO filling is equal or higher than WTM level)
OVRN	Overflow bit status. (0: FIFO is not completely filled; 1: FIFO is completely filled)
EMPTY	FIFO empty bit. (0: FIFO not empty; 1: FIFO empty)
FSS4-FSS1	FIFO stored data level

7.37 INT1_CFG_G (30h)

This is the configuration register for the interrupt source.

Table 90. INT1_CFG_G register

AND/OR	LIR	ZHIE	ZLIE	YHIE	YLIE	XHIE	XLIE
--------	-----	------	------	------	------	------	------

Table 91. INT1_CFG_G description

AND/OR	AND/OR combination of interrupt events. Default value: 0 (0: OR combination of interrupt events 1: AND combination of interrupt events)
LIR	Latch Interrupt Request. Default value: 0 (0: interrupt request not latched; 1: interrupt request latched) Cleared by reading INT1_SRC_G reg.
ZHIE	Enable interrupt generation on Z high event. Default value: 0 (0: disable interrupt request; 1: enable interrupt request on measured accel. value higher than preset threshold)
ZLIE	Enable interrupt generation on Z low event. Default value: 0 (0: disable interrupt request; 1: enable interrupt request on measured accel. value lower than preset threshold)
YHIE	Enable interrupt generation on Y high event. Default value: 0 (0: disable interrupt request; 1: enable interrupt request on measured accel. value higher than preset threshold)
YLIE	Enable interrupt generation on Y low event. Default value: 0 (0: disable interrupt request; 1: enable interrupt request on measured accel. value lower than preset threshold)
XHIE	Enable interrupt generation on X high event. Default value: 0 (0: disable interrupt request; 1: enable interrupt request on measured accel. value higher than preset threshold)
XLIE	Enable interrupt generation on X low event. Default value: 0 (0: disable interrupt request; 1: enable interrupt request on measured accel. value lower than preset threshold)

7.38 INT1_SRC_G (31h)

The interrupt source register is a read-only register.

Reading at this address clears the INT1_SRC_G IA bit (and eventually the interrupt signal on the INT1_G pin) and allows the refreshment of data in the INT1_SRC_G register if the latched option was chosen.

Table 92. INT1_SRC_G register

0 ⁽¹⁾	IA	ZH	ZL	YH	YL	XH	XL
------------------	----	----	----	----	----	----	----

1. This bit has to be set to '0' for correct operation.

Table 93. INT1_SRC_G description

IA	Interrupt active. Default value: 0 (0: no interrupt has been generated; 1: one or more interrupts have been generated)
ZH	Z high. Default value: 0 (0: no interrupt, 1: Z high event has occurred)
ZL	Z low. Default value: 0 (0: no interrupt; 1: Z low event has occurred)
YH	Y high. Default value: 0 (0: no interrupt, 1: Y high event has occurred)
YL	Y low. Default value: 0 (0: no interrupt, 1: Y low event has occurred)
XH	X high. Default value: 0 (0: no interrupt, 1: X high event has occurred)
XL	X low. Default value: 0 (0: no interrupt, 1: X low event has occurred)

7.39 INT1_THS_XH_G (32h)

Table 94. INT1_THS_XH_G register

--	THSX14	THSX13	THSX12	THSX11	THSX10	THSX9	THSX8
----	--------	--------	--------	--------	--------	-------	-------

Table 95. INT1_THS_XH_G description

THSX14 - THSX9	Interrupt threshold. Default value: 0000 0000
----------------	---

7.40 INT1_THS_XL_G (33h)

Table 96. INT1_THS_XL_G register

THSX7	THSX6	THSX5	THSX4	THSX3	THSX2	THSX1	THSX0
-------	-------	-------	-------	-------	-------	-------	-------

Table 97. INT1_THS_XL_G description

THSX7 - THSX0	Interrupt threshold. Default value: 0000 0000
---------------	---

7.41 INT1_THS_YH_G (34h)

Table 98. INT1_THS_YH_G register

--	THSY14	THSY13	THSY12	THSY11	THSY10	THSY9	THSY8
----	--------	--------	--------	--------	--------	-------	-------

Table 99. INT1_THS_YH_G description

THSY14 - THSY9	Interrupt threshold. Default value: 0000 0000
----------------	---

7.42 INT1_THS_YL_G (35h)

Table 100. INT1_THS_YL_G register

THSR7	THSY6	THSY5	THSY4	THSY3	THSY2	THSY1	THSY0
-------	-------	-------	-------	-------	-------	-------	-------

Table 101. INT1_THS_YL_G description

THSY7 - THSY0	Interrupt threshold. Default value: 0000 0000
---------------	---

7.43 INT1_THS_ZH_G (36h)

Table 102. INT1_THS_ZH_G register

--	THSZ14	THSZ13	THSZ12	THSZ11	THSZ10	THSZ9	THSZ8
----	--------	--------	--------	--------	--------	-------	-------

Table 103. INT1_THS_ZH_G description

THSZ14 - THSZ9	Interrupt threshold. Default value: 0000 0000
----------------	---

7.44 INT1_THS_ZL_G (37h)

Table 104. INT1_THS_ZL_G register

THSZ7	THSZ6	THSZ5	THSZ4	THSZ3	THSZ2	THSZ1	THSZ0
-------	-------	-------	-------	-------	-------	-------	-------

Table 105. INT1_THS_ZL_G description

THSZ7 - THSZ0	Interrupt threshold. Default value: 0000 0000
---------------	---

7.45 INT1_DURATION_G (38h)

Table 106. INT1_DURATION_G register

WAIT	D6	D5	D4	D3	D2	D1	D0
------	----	----	----	----	----	----	----

Table 107. INT1_DURATION_G description

WAIT	WAIT enable. Default value: 0 (0: disable; 1: enable)
D6 - D0	Duration value. Default value: 000 0000

The **D6 - D0** bits set the minimum duration of the interrupt event to be recognized. The duration of the steps and maximum values depend on the ODR chosen.

The **WAIT** bit has the following meaning:

Wait = '0': the interrupt falls immediately if the signal crosses the selected threshold

Wait = '1': if the signal crosses the selected threshold, the interrupt falls only after the duration has counted the number of samples at the selected data rate, written into the duration counter register.

Figure 13. Wait disabled

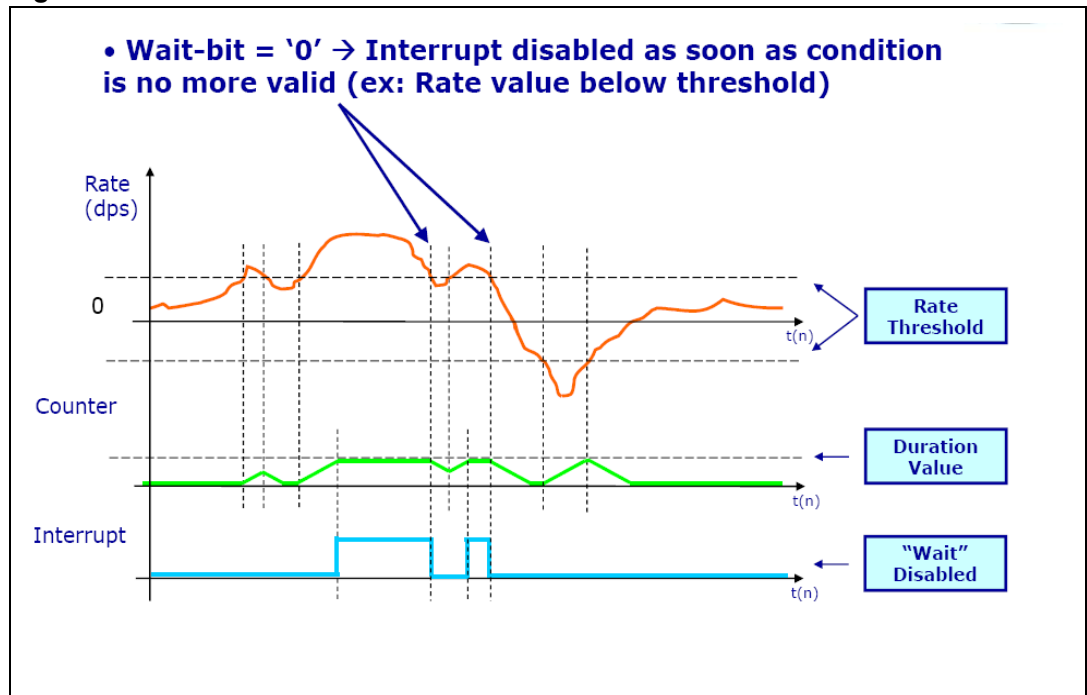
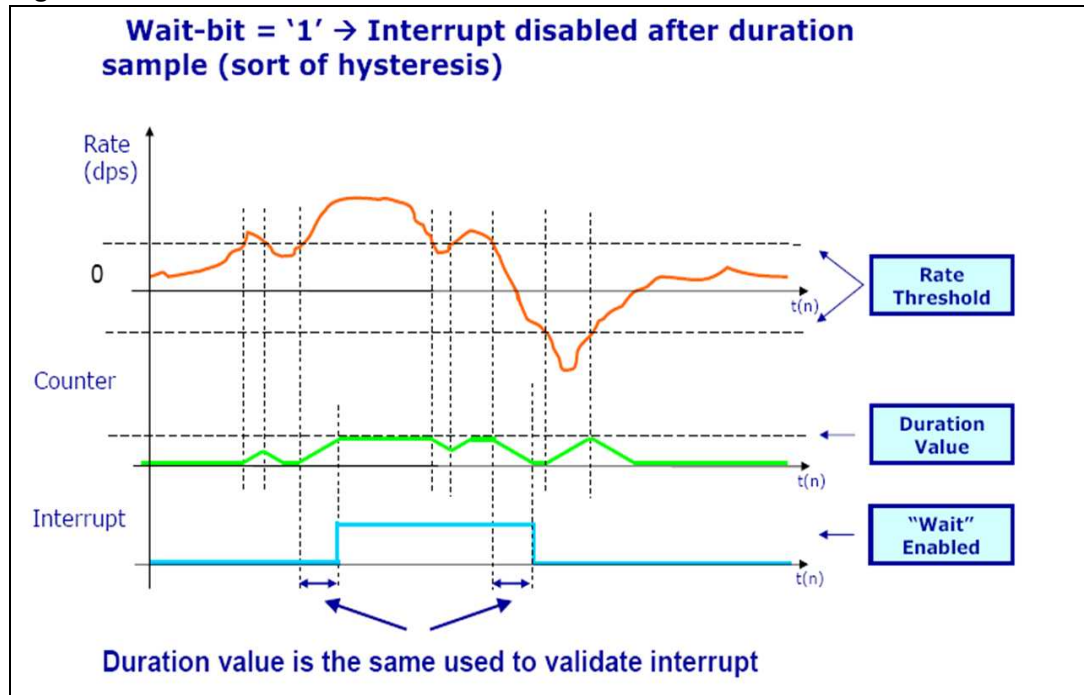

Figure 14. Wait enabled



8 Package information

In order to meet environmental requirements, ST offers these devices in different grades of ECOPACK[®] packages, depending on their level of environmental compliance. ECOPACK[®] specifications, grade definitions and product status are available at: www.st.com. ECOPACK is an ST trademark.

ECOPACK[®] specifications are available at: www.st.com.

Table 108. LLGA 7.5 x 4.4 x 1.1 28L mechanical data

Dim.	mm		
	Min.	Typ.	Max.
A1			1.100
A2		0.855	
A3		0.200	
D1	4.250	4.400	4.550
E1	7.350	7.500	7.650
N1		0.300	
L1		5.400	
L2		1.800	
P2		1.200	
T1		0.600	
T2		0.400	
M		0.100	
d		0.3	
k		0.050	
h		0.100	

Figure 15. LLGA 7.5 x 4.4 x 1.1 28L package drawing

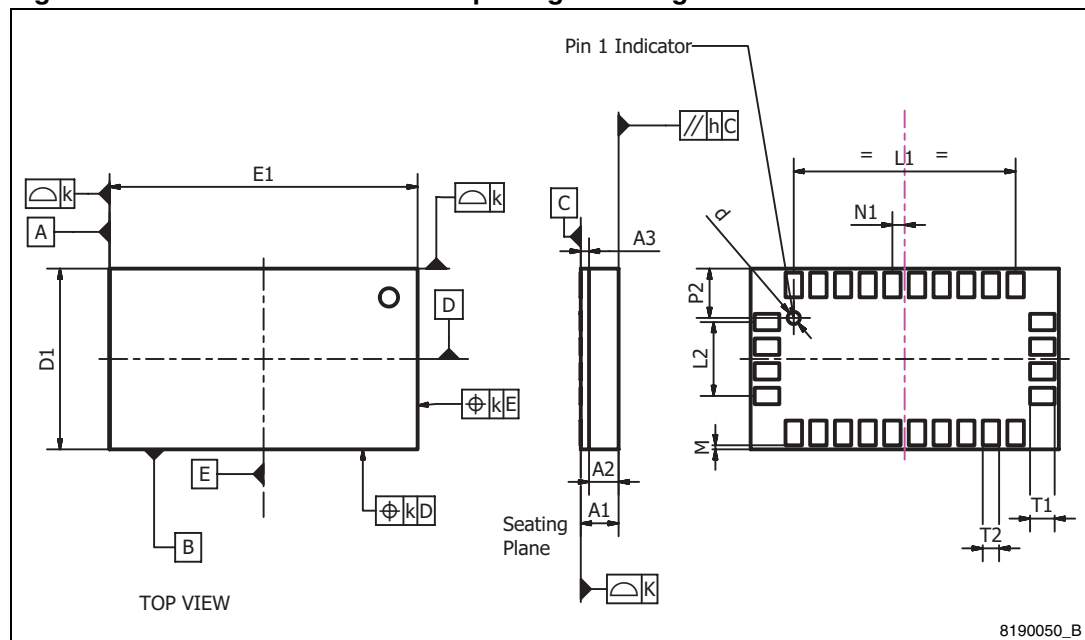

9 Revision history

Table 109. Document revision history

Date	Revision	Changes
19-Jul-2011	1	First release.

Please Read Carefully:

Information in this document is provided solely in connection with ST products. STMicroelectronics NV and its subsidiaries ("ST") reserve the right to make changes, corrections, modifications or improvements, to this document, and the products and services described herein at any time, without notice.

All ST products are sold pursuant to ST's terms and conditions of sale.

Purchasers are solely responsible for the choice, selection and use of the ST products and services described herein, and ST assumes no liability whatsoever relating to the choice, selection or use of the ST products and services described herein.

No license, express or implied, by estoppel or otherwise, to any intellectual property rights is granted under this document. If any part of this document refers to any third party products or services it shall not be deemed a license grant by ST for the use of such third party products or services, or any intellectual property contained therein or considered as a warranty covering the use in any manner whatsoever of such third party products or services or any intellectual property contained therein.

UNLESS OTHERWISE SET FORTH IN ST'S TERMS AND CONDITIONS OF SALE ST DISCLAIMS ANY EXPRESS OR IMPLIED WARRANTY WITH RESPECT TO THE USE AND/OR SALE OF ST PRODUCTS INCLUDING WITHOUT LIMITATION IMPLIED WARRANTIES OF MERCHANTABILITY, FITNESS FOR A PARTICULAR PURPOSE (AND THEIR EQUIVALENTS UNDER THE LAWS OF ANY JURISDICTION), OR INFRINGEMENT OF ANY PATENT, COPYRIGHT OR OTHER INTELLECTUAL PROPERTY RIGHT.

UNLESS EXPRESSLY APPROVED IN WRITING BY AN AUTHORIZED ST REPRESENTATIVE, ST PRODUCTS ARE NOT RECOMMENDED, AUTHORIZED OR WARRANTED FOR USE IN MILITARY, AIR CRAFT, SPACE, LIFE SAVING, OR LIFE SUSTAINING APPLICATIONS, NOR IN PRODUCTS OR SYSTEMS WHERE FAILURE OR MALFUNCTION MAY RESULT IN PERSONAL INJURY, DEATH, OR SEVERE PROPERTY OR ENVIRONMENTAL DAMAGE. ST PRODUCTS WHICH ARE NOT SPECIFIED AS "AUTOMOTIVE GRADE" MAY ONLY BE USED IN AUTOMOTIVE APPLICATIONS AT USER'S OWN RISK.

Resale of ST products with provisions different from the statements and/or technical features set forth in this document shall immediately void any warranty granted by ST for the ST product or service described herein and shall not create or extend in any manner whatsoever, any liability of ST.

ST and the ST logo are trademarks or registered trademarks of ST in various countries.

Information in this document supersedes and replaces all information previously supplied.

The ST logo is a registered trademark of STMicroelectronics. All other names are the property of their respective owners.

© 2011 STMicroelectronics - All rights reserved

STMicroelectronics group of companies

Australia - Belgium - Brazil - Canada - China - Czech Republic - Finland - France - Germany - Hong Kong - India - Israel - Italy - Japan - Malaysia - Malta - Morocco - Philippines - Singapore - Spain - Sweden - Switzerland - United Kingdom - United States of America

www.st.com