

Memory module temperature sensor

Features

- Temperature sensor compliant with JEDEC JC42.4

Temperature sensor

- Temperature sensor resolution: 0.25°C (typ)/LSB
- Temperature sensor accuracy:
 - ± 1°C from +75°C to +95°C
 - ± 2°C from +40°C to +125°C
 - ± 3°C from –40°C to +125°C
- ADC conversion time: 125 ms (max)
- Supply voltage: 2.7 V to 3.6 V
- Maximum operating supply current: 200 µA
- Hysteresis selectable set points from: 0, 1.5, 3, 6.0°C
- Ambient temperature sensing range: –40°C to 125°C
- Supports bus timeout

Two-wire bus

- 2-wire SMBus/I²C - compatible serial interface
- Supports up to 400 kHz transfer rate
- Does not initiate clock stretching

Packages

- 2 mm x 3 mm TDFN8, height: 0.80 mm (max)^(a)
- RoHS compliant, halogen-free

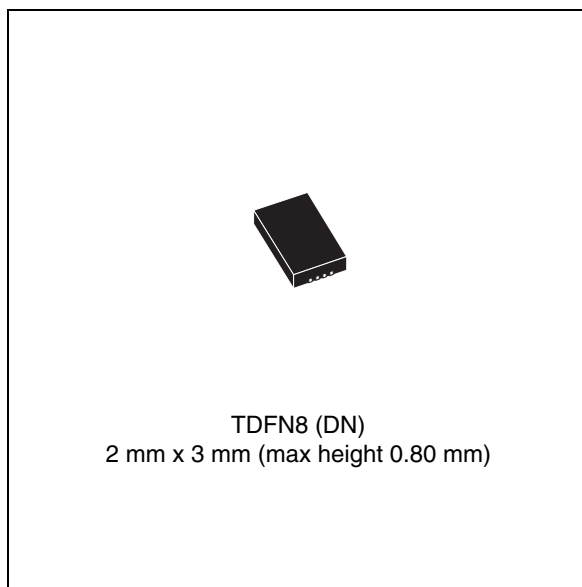

a. Compliant to JEDEC MO-229, WCED-3

Contents

1	Description	6
2	Serial communications	7
2.1	Device type identifier (DTI) code	7
2.2	Pin descriptions	9
2.2.1	A0, A1, A2	9
2.2.2	V _{SS} (ground)	9
2.2.3	SDA (open drain)	9
2.2.4	SCL	9
2.2.5	$\overline{\text{EVENT}}$ (open drain)	9
2.2.6	V _{DD} (power)	9
3	Operation	10
3.1	SMBus/I ² C communications	10
3.2	SMBus/I ² C slave sub-address decoding	12
3.3	SMBus/I ² C AC timing consideration	12
3.4	SMBus timeout	13
4	Temperature sensor registers	14
4.1	Capability register (read-only)	15
4.1.1	Alarm window trip	15
4.1.2	Critical trip	15
4.2	Configuration register (read/write)	17
4.2.1	Event thresholds	17
4.2.2	Interrupt mode	17
4.2.3	Comparator mode	17
4.2.4	Shutdown mode	17
4.2.5	Event output pin functionality	20
4.3	Temperature register (read-only)	22
4.3.1	Temperature format	22
4.4	Temperature trip point registers (r/w)	23
4.5	Manufacturer ID register (read-only)	24
4.6	Device ID and device revision ID register (read-only)	25

5	Maximum ratings	26
6	DC and AC parameters	27
7	Package mechanical data	29
8	Part numbering	31
9	Package marking information	32
10	Landing pattern	33
11	Revision history	35

List of tables

Table 1.	Signal names	7
Table 2.	AC SMBus and I ² C compatibility timings	13
Table 3.	Temperature sensor registers summary	14
Table 4.	Pointer register format	14
Table 5.	Pointer register select bits (type, width, and default values)	15
Table 6.	Capability register format	16
Table 7.	Capability register bit definitions	16
Table 8.	Configuration register format	17
Table 9.	Configuration register bit definitions	18
Table 10.	Hysteresis as applied to temperature movement	19
Table 11.	Legend for <i>Figure 9: Event output boundary timings</i>	21
Table 12.	Temperature register format	22
Table 13.	Temperature register bit definitions	23
Table 14.	Temperature trip point register format	23
Table 15.	Alarm temperature upper boundary register format	23
Table 16.	Alarm temperature lower boundary register format	24
Table 17.	Critical temperature register format	24
Table 18.	Manufacturer ID register format	24
Table 19.	Device ID and device revision ID register format	25
Table 20.	Absolute maximum ratings	26
Table 21.	Operating and AC measurement conditions	27
Table 22.	DC and AC characteristics - temperature sensor	28
Table 23.	TDFN8 – 8-lead thin dual flat, no-lead (2 mm x 3 mm) mechanical data (DN)	30
Table 24.	Ordering information scheme	31
Table 25.	Parameters for landing pattern - TDFN package (DN)	34
Table 26.	Document revision history	35

List of figures

Figure 1.	Logic diagram	7
Figure 2.	TDFN8 connections (top view)	8
Figure 3.	Block diagram	8
Figure 4.	SMBus/I ² C write to pointer register	11
Figure 5.	SMBus/I ² C write to pointer register, followed by a read data word.	11
Figure 6.	SMBus/I ² C write to pointer register, followed by a write data word	12
Figure 7.	SMBus/I ² C timing diagram	13
Figure 8.	Hysteresis	19
Figure 9.	Event output boundary timings	21
Figure 10.	TDFN8 – 8-lead thin dual flat, no-lead (2 mm x 3 mm) package outline (DN)	30
Figure 11.	Device topside marking information (TDFN-8L)	32
Figure 12.	Landing pattern - TDFN package (DN)	33

1 Description

The STTS424 is targeted for DIMM modules in mobile personal computing platforms (laptops), server memory modules, and other industrial applications. The thermal sensor (TS) in the STTS424 is fully compliant with the JEDEC specification which defines memory module thermal sensors requirements for mobile platforms.

The TS provides space as well as cost savings for mobile and server platform dual inline memory modules (DIMM) manufacturers as it is packaged in the compact 2 mm x 3 mm (height 0.80 mm) 8-lead TDFN package which is compliant to JEDEC MO-229, variation WCED-3.

The temperature sensor includes a band gap-based temperature sensor and 10-bit analog-to-digital converter (ADC) which monitor and digitize the temperature to a resolution of up to 0.25°C. The typical accuracies over these temperature ranges are:

- $\pm 3^{\circ}\text{C}$ (max) over the full temperature measurement range of -40°C to 125°C
- $\pm 2^{\circ}\text{C}$ in the $+40^{\circ}\text{C}$ to $+125^{\circ}\text{C}$ temperature range and
- $\pm 1^{\circ}\text{C}$ in the $+75^{\circ}\text{C}$ to $+95^{\circ}\text{C}$ temperature range

The temperature sensor in the STTS424 is specified for operating at supply voltages from 2.7 V to 3.6 V. Operating at 3.3 V, the supply current is 100 μA (typ).

The on-board sigma delta ADC converts the measured temperature to a digital value that is calibrated in °C. For Fahrenheit applications, a lookup table or conversion routine is required. The STTS424 is factory-calibrated and requires no external components to measure temperature.

The digital temperature sensor component has user-programmable registers that provide the capabilities for DIMM temperature-sensing applications. The open drain event output pin is active when the monitoring temperature exceeds a programmable limit, or it falls above or below an alarm window. The user has the option to set the event output as a critical temperature output. This pin can be configured to operate in either a comparator mode for thermostat operation or in interrupt mode.

2 Serial communications

The STTS424 has a simple 2-wire SMBus/I²C-compatible digital serial interface which allows the user to access the data in the temperature register at any time. It communicates via the serial interface with a master controller which operates at speeds of up to 400 kHz. It also gives the user easy access to all of the STTS424 registers in order to customize device operation.

2.1 Device type identifier (DTI) code

The JC42.4 temperature sensor has its own unique I²C address, which ensures that there are no compatibility or data translation issues. The DTI code is the unique 4-bit address, '0011'.

The full I²C address consists of the unique DTI code and 3 bits determined by the A0, A1, and A2 pins. This allows up to 8 unique addresses, hence 8 STTS424 devices may be connected on the same bus.

Figure 1. Logic diagram

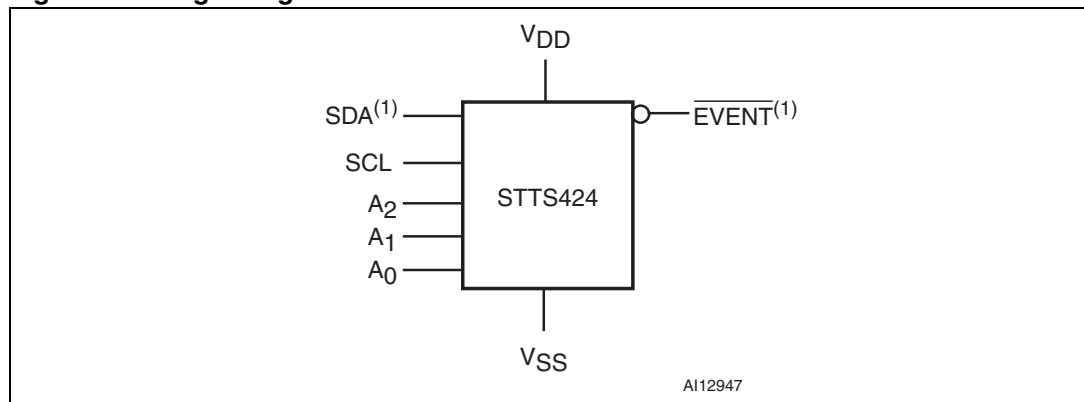

1. SDA and $\overline{\text{EVENT}}$ are open drain.

Table 1. Signal names

Pin	Symbol	Description	Direction
1	A0	Serial bus address selection pin. Can be tied to V _{SS} or V _{DD} .	Input
2	A1	Serial bus address selection pin. Can be tied to V _{SS} or V _{DD} .	Input
3	A2	Serial bus address selection pin. Can be tied to V _{SS} or V _{DD} .	Input
4	V _{SS}	Supply ground	
5	SDA ⁽¹⁾	Serial data	Input/output
6	SCL	Serial clock	Input
7	$\overline{\text{EVENT}}$ ⁽¹⁾	Event output pin. Open drain and active-low.	Output
8	V _{DD}	Supply power (2.7 V to 3.6 V)	

1. SDA and $\overline{\text{EVENT}}$ are open drain.

See [Section 2.2: Pin descriptions on page 9](#) for details.

Figure 2. TDFN8 connections (top view)

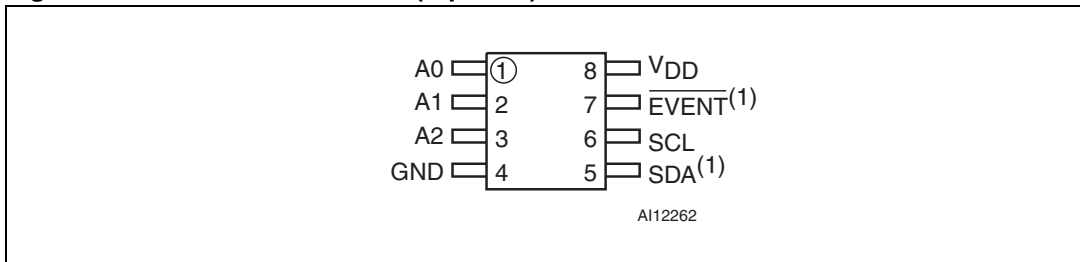

1. SDA and $\overline{\text{EVENT}}$ are open drain.

Figure 3. Block diagram

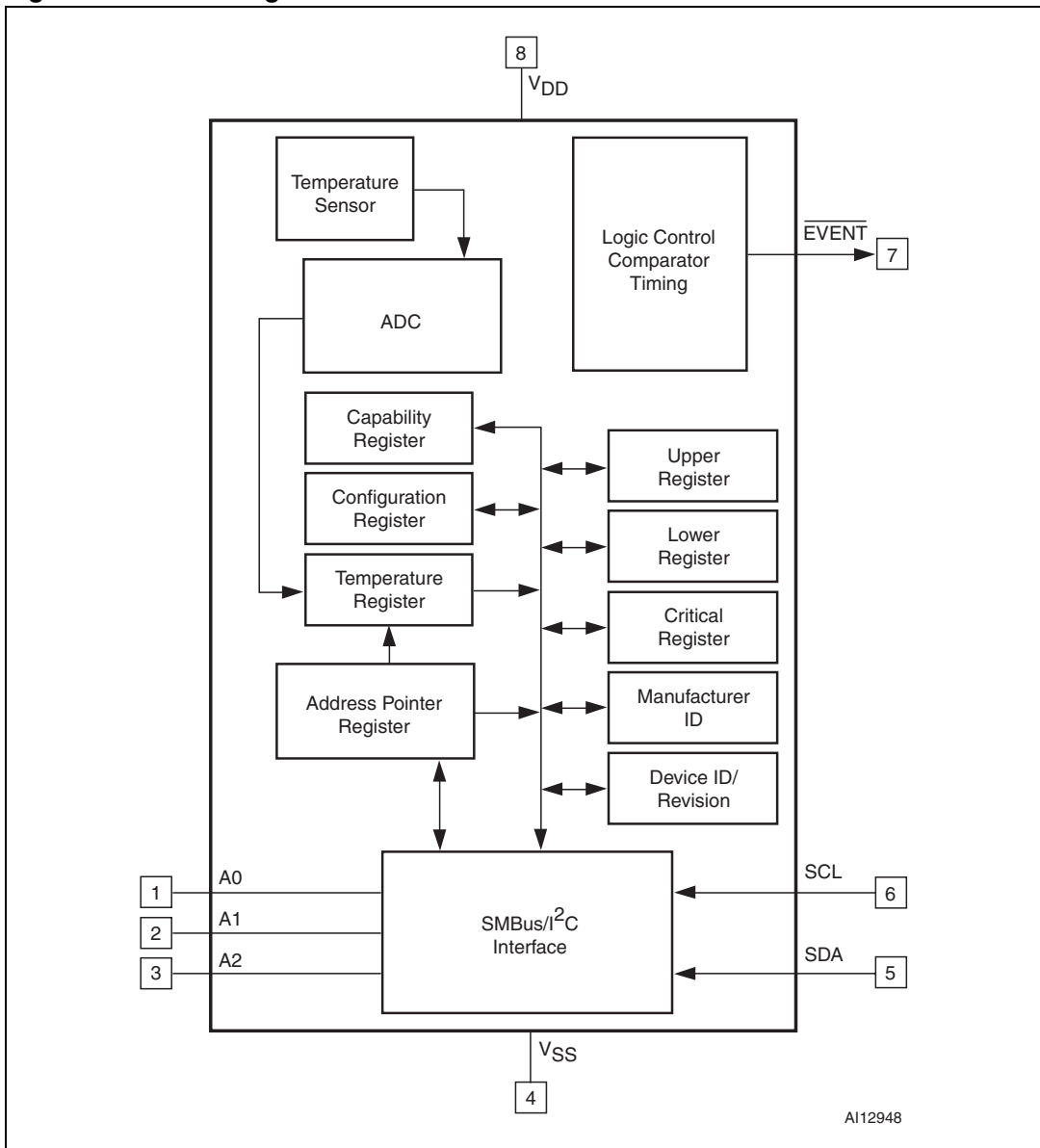

2.2 Pin descriptions

2.2.1 A0, A1, A2

A2, A1, and A0 are selectable address pins for the 3 LSBs of the I²C interface address. They can be set to V_{DD} or GND to provide 8 unique address selections.

2.2.2 V_{SS} (ground)

This is the reference for the power supply. It must be connected to system ground.

2.2.3 SDA (open drain)

This is the serial data input/output pin.

2.2.4 SCL

This is the serial clock input pin.

2.2.5 $\overline{\text{EVENT}}$ (open drain)

This output pin is open drain and active-low and functions as an alert interrupt.

2.2.6 V_{DD} (power)

This is the supply voltage pin, and ranges from +2.7 V to +3.6 V.

3 Operation

The STTS424 TS continuously monitors the ambient temperature and updates the temperature data registers at least eight times per second. Temperature data is latched internally by the device and may be read by software from the bus host at any time.

The SMBus/I²C slave address selection pins allow up to 8 such devices to co-exist on the same bus. This means that up to 8 memory modules can be supported, given that each module has one such slave device address slot.

After initial power-on, the configuration registers are set to the default values. The software can write to the configuration register to set bits per the bit definitions in [Section 3.1: SMBus/I²C communications](#).

3.1 SMBus/I²C communications

The registers in this device are selected by the pointer register. At power-up, the pointer register is set to "00", which is the capability register location. The pointer register latches the last location it was set to. Each data register falls into one of three types of user accessibility:

1. Read-only
2. Write-only and
3. WRITE/READ same address.

A WRITE to this device will always include the address byte and the pointer byte. A WRITE to any register other than the pointer register, requires two data bytes.

Reading this device is achieved in one of two ways:

- If the location latched in the pointer register is correct (most of the time it is expected that the pointer register will point to one of the read temperature registers because that will be the data most frequently read), then the READ can simply consist of an address byte, followed by retrieval of the two data bytes.
- If the pointer register needs to be set, then an address byte, pointer byte, repeat start, and another address byte will accomplish a READ.

The data byte transfers the MSB first. At the end of a READ, this device can accept either an acknowledge (ACK) or no acknowledge (No ACK) status from the master. The No ACK status is typically used as a signal for the slave that the master has read its last byte. This device subsequently takes up to 125 ms to measure the temperature.

Note: STTS424 does not initiate clock stretching which is an optional I²C bus feature.

Figure 4. SMBus/I²C write to pointer register

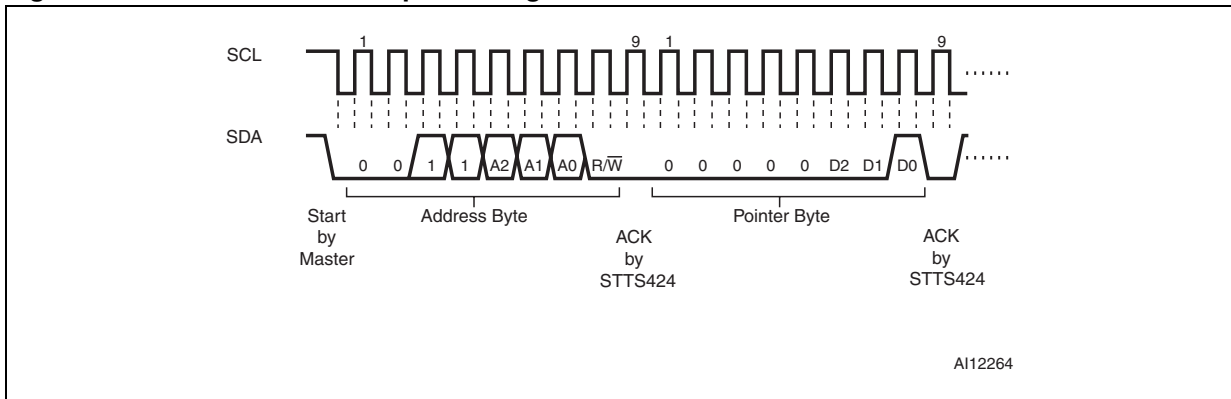

Figure 5. SMBus/I²C write to pointer register, followed by a read data word

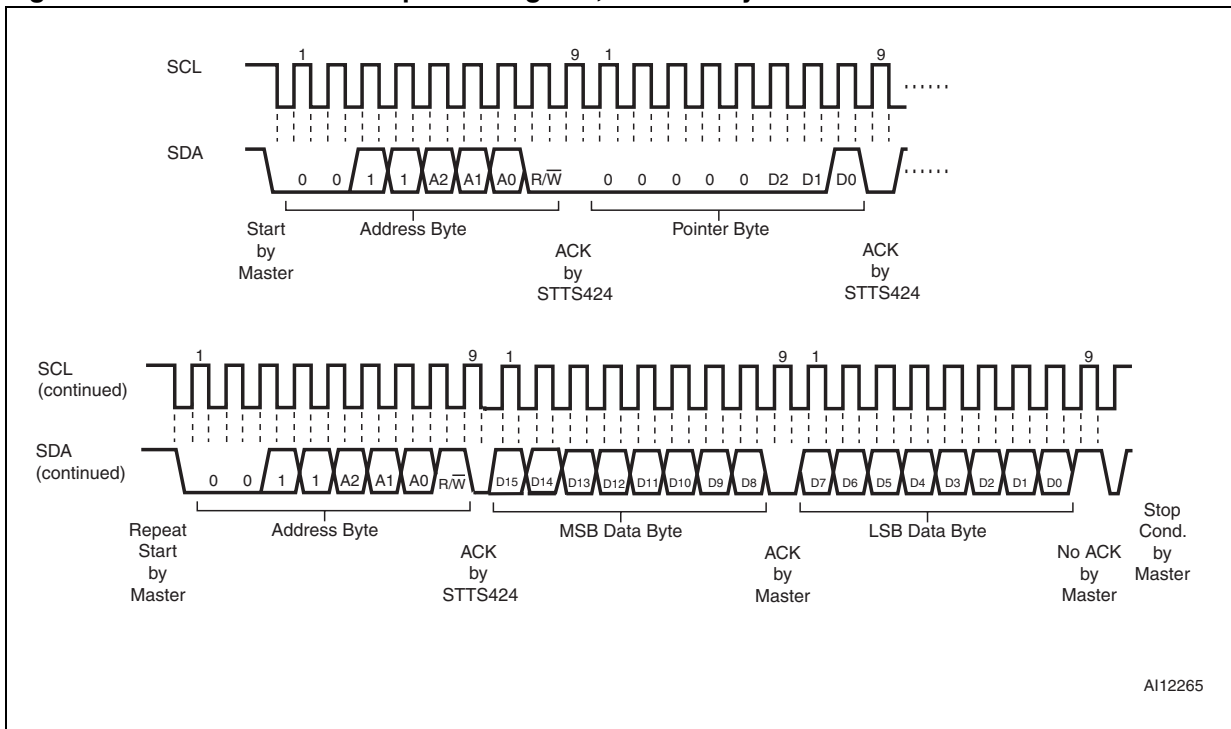
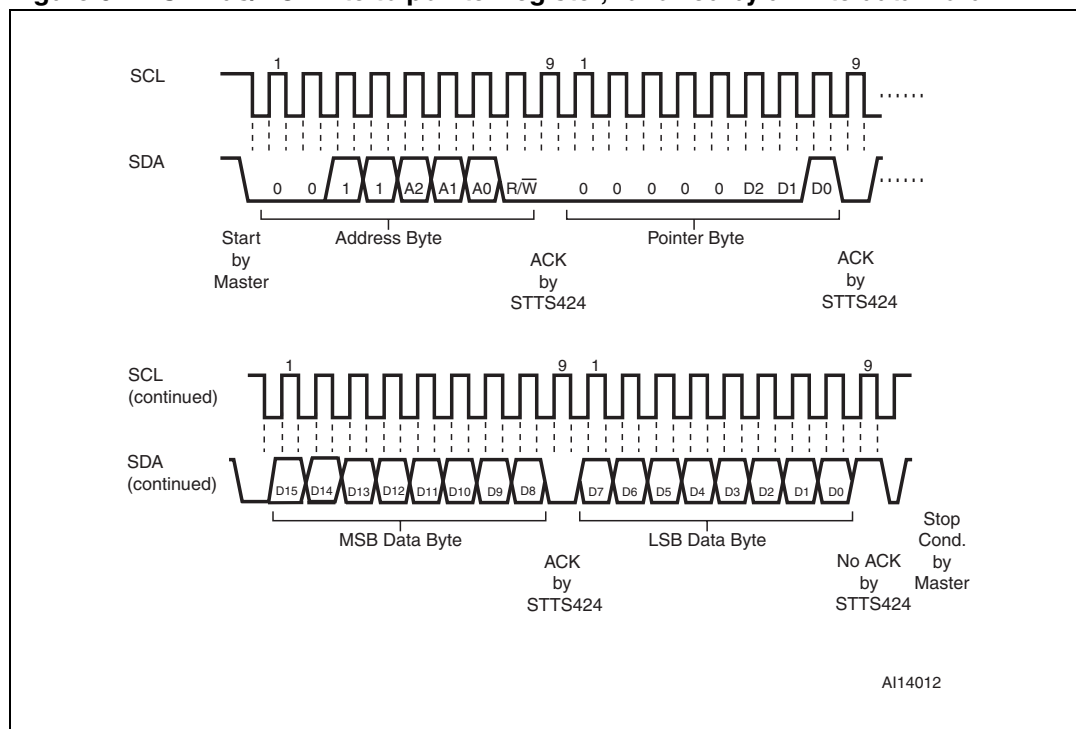

Figure 6. SMBus/I²C write to pointer register, followed by a write data word



3.2 SMBus/I²C slave sub-address decoding

The physical address for the TS is binary 0 0 1 1 A2 A1 A0 RW, whereas A2, A1, and A0 are the three slave sub-address pins, and the LSB “RW” is the READ/WRITE flag.

3.3 SMBus/I²C AC timing consideration

In order for this device to be both SMBus- and I²C-compatible, it complies to a subset of each specification. These interoperability requirements which will enable this device to co-exist with devices on either an SMBus or an I²C bus:

- The SMBus minimum clock frequency is required.
- The 300 ns SMBus data hold time (THD:DAT) is required (see [Figure 7](#) and [Table 2 on page 13](#)).
- The SMBus time-out is maximum 50 ms.

Note: Since the voltage levels are specified only within 3.3 V ±10%, there are no compatibility concerns with the SMBus/I²C DC specifications.

Figure 7. SMBus/I²C timing diagram

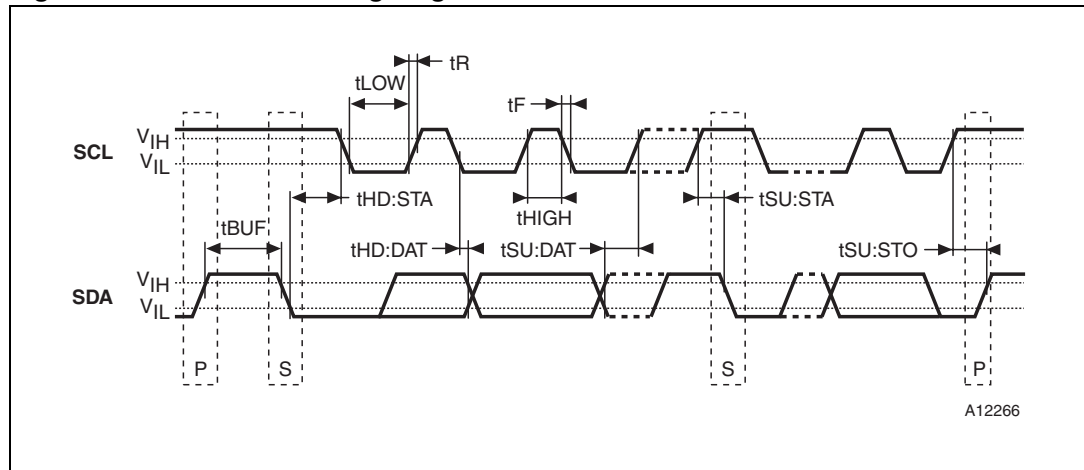

Table 2. AC SMBus and I²C compatibility timings

Symbol	Parameter	Min	Max	Units
t_{BUF}	Bus free time between stop (P) and start (S) conditions	1.3	–	μ s
$t_{HD:STA}$	Hold time after (repeated) start condition. After this period, the first clock cycle is generated.	0.6	–	μ s
$t_{SU:STA}^{(1)}$	Repeated start condition setup time	1.3	–	μ s
t_{HIGH}	Clock high period	0.6	–	μ s
t_{LOW}	Clock low period	1.3	–	μ s
t_F	Clock/data fall time	–	300	ns
t_R	Clock/data rise time	–	300	ns
$t_{SU:DAT}$	Data setup time	100	–	ns
$t_{HD:DAT}$	Data hold time	300	–	ns
$t_{SU:STO}$	Stop condition setup time	0.6	–	μ s
f_{SCL}	SMBUS/I ² C clock frequency	10	400	kHz
$t_{timeout}$	Bus timeout	25	50	ms

1. For a restart condition, or following a WRITE cycle

3.4 SMBus timeout

The STTS424 supports the SMBus timeout feature. If the host holds SCL low for more than 25 ms, the STTS424 resets and releases the bus. This feature is turned on by default.

4 Temperature sensor registers

The temperature sensor component is comprised of various user-programmable registers. These registers are required to write their corresponding addresses to the Pointer register. They can be accessed by writing to their respective addresses (see [Table 3](#)). Pointer register Bits 7-3 must always be written to '0' (see [Table 4](#)). This must be maintained, as not setting these bits to '0' may keep the device from performing to specifications.

The main registers include:

- [Capability register \(read-only\)](#)
- [Configuration register \(read/write\)](#)
- [Temperature register \(read-only\)](#)
- [Temperature trip point registers \(r/w\)](#), including
 - Alarm temperature upper boundary,
 - Alarm temperature lower boundary, and
 - Critical temperature.
- [Manufacturer ID register format](#)
- [Device ID and device revision ID register format](#)

Note: See [Table 5 on page 15](#) for pointer register selection bit details.

Table 3. Temperature sensor registers summary

Address (Hex)	Register name		Power-on default
Not applicable	Address pointer		Undefined
00	Capability	B-grade only	0x002F
01	Configuration		0x0000
02	Alarm temperature upper boundary trip		0x0000
03	Alarm temperature lower boundary trip		0x0000
04	Critical temperature trip		0x0000
05	Temperature		Undefined
06	Manufacturer's ID		0x104A
07	Device ID/revision		0x0101

Table 4. Pointer register format

MSB						LSB	
Bit7	Bit6	Bit5	Bit4	Bit3	Bit2	Bit1	Bit0
0	0	0	0	0	P2	P1	P0
						Pointer/register select bits	

Table 5. Pointer register select bits (type, width, and default values)

P2	P1	P0	Name	Register description	Width (bits)	Type (R/W)	Default state (POR)	
0	0	0	CAPA	Thermal sensor capabilities	B-grade only	16	R	00 2F
0	0	1	CONF	Configuration		16	R/W	00 00
0	1	0	UPPER	Alarm temperature upper boundary		16	R/W	00 00
0	1	1	LOWER	Alarm temperature lower boundary		16	R/W	00 00
1	0	0	CRITICAL	Critical temperature		16	R/W	00 00
1	0	1	TEMP	Temperature		16	R	00 00
1	1	0	MANU	Manufacturer ID		16	R	104A
1	1	1	ID	Device ID/revision		16	R	01 01

4.1 Capability register (read-only)

This 16-bit register is read-only, and provides the TS capabilities which comply with the minimum JEDEC 424.4 specifications (see [Table 6](#) and [Table 7 on page 16](#)). The STTS424 provides temperatures at 0.25 resolution (10-bit).

4.1.1 Alarm window trip

The device provides a comparison window with an upper temperature trip point in the alarm upper boundary register, and a lower trip point in the alarm lower boundary register. When enabled, the event output will be triggered whenever entering or exiting (crossing above or below) the alarm window.

4.1.2 Critical trip

The device can be programmed in such a way that the event output is only triggered when the temperature exceeds the critical trip point. The critical temperature setting is programmed in the critical temperature register. When the temperature sensor reaches the critical temperature value in this register, the device is automatically placed in comparator mode, which means that the critical event output cannot be cleared by using software to set the clear event bit.

Table 6. Capability register format

Bit15	Bit14	Bit13	Bit12	Bit11	Bit10	Bit9	Bit8
RFU	RFU	RFU	RFU	RFU	RFU	RFU	RFU
Bit7	Bit6	Bit5	Bit4	Bit3	Bit2	Bit1	Bit0
RFU	RFU	V _{HV}	TRES1	TRES0	Wider range	Higher precision	Alarm and critical trips

Table 7. Capability register bit definitions

Bit	Definition
0	Basic capability – 0 = Alarm and critical trips turned OFF. – 1 = Alarm and critical trips turned ON.
1	Accuracy – 0 = Accuracy $\pm 2^{\circ}\text{C}$ over the active range and $\pm 3^{\circ}\text{C}$ over the monitoring range (C - Grade). – 1 = High accuracy $\pm 1^{\circ}\text{C}$ over the active range and $\pm 2^{\circ}\text{C}$ over the monitoring range (B - Grade).
2	Range width – 0 = Values lower than 0°C will be clamped and represented as binary value '0'. – 1 = Temperatures below 0°C can be read and the Sign bit will be set accordingly.
4:3	Temperature resolution – 01 = This 10-bit value is fixed for STTS424, providing temperatures at 0.25°C resolution (LSB).
5	(V _{HV}) High voltage support for A0 (pin 1) – 1 = STTS424 supports a voltage up to 10 volts on the A0 pin (default).
15:6	Reserved These values must be set to '0'.

4.2 Configuration register (read/write)

The 16 bit Configuration register stores various configuration modes that are used to set up the sensor registers and configure according to application and JEDEC 42.4 requirements (see [Table 8 on page 17](#) and [Table 9 on page 18](#)).

4.2.1 Event thresholds

All event thresholds use hysteresis as programmed in register address 0x01 (bits 10 through 9) to be set when they de-assert.

4.2.2 Interrupt mode

The interrupt mode allows an event to occur where software may write a '1' to the clear event bit (bit 5) to de-assert the event Interrupt output until the next trigger condition occurs.

4.2.3 Comparator mode

Comparator mode enables the device to be used as a thermostat. READs and WRITEs on the device registers will not affect the event output in comparator mode. The event signal will remain asserted until temperature drops outside the range or is re-programmed to make the current temperature “out of range”.

4.2.4 Shutdown mode

The STTS424 features a shutdown mode which disables all power-consuming activities (e.g. temperature sampling operations), and leaves the serial interface active. This is selected by setting shutdown bit (bit 8) to '1'. In this mode, the devices consume the minimum current (I_{SHDN}), as shown in [Table 22 on page 28](#).

Note: Bit 8 cannot be set to '1' while bits 6 and 7 (the lock bits) are set to '1'.

The device may be enabled for continuous operation by clearing bit 8 to '0'. In shutdown mode, all registers may be read or written to. Power recycling will also clear this bit and return the device to continuous mode as well.

Table 8. Configuration register format

Bit15	Bit14	Bit13	Bit12	Bit11	Bit10	Bit9	Bit8
RFU	RFU	RFU	RFU	RFU	Hysteresis	Hysteresis	Shutdown mode
Bit7	Bit6	Bit5	Bit4	Bit3	Bit2	Bit1	Bit0
Critical lock bit	Alarm lock bit	Clear event	Event output status	Event output control	Critical event only	Event polarity	Event mode

Table 9. Configuration register bit definitions

Bit	Definition
0	Event mode – 0 = Comparator output mode (this is the default) – 1 = Interrupt mode; when either of the lock bits is set, this bit cannot be altered until it is unlocked.
1	Event polarity – 0 = Active-low (this is the default). – 1 = Active-high; when either of the lock bits is set, this bit cannot be altered until it is unlocked.
2	Critical event only – 0 = Event output on alarm or critical temperature event (this is the default). – 1 = Event only if the temperature is above the value in the critical temperature register; when the alarm window lock bit is set, this bit cannot be altered until it is unlocked.
3	Event output control – 0 = Event output disabled (this is the default). – 1 = Event output enabled; when either of the lock bits is set, this bit cannot be altered until it is unlocked.
4	Event status (read-only) ⁽¹⁾ – 0 = Event output condition is not being asserted by this device. – 1 = Event output condition is being asserted by this device via the alarm window or critical trip event.
5	Clear event (write-only) ⁽²⁾ – 0 = No effect – 1 = Clears the active Event in Interrupt mode.
6	Alarm window lock bit – 0 = Alarm trips are not locked and can be altered (this is the default). – 1 = Alarm trip register settings cannot be altered. This bit is initially cleared. When set, this bit returns a logic '1' and remains locked until cleared by an internal power-on reset. These bits can be written to with a single WRITE, and do not require double WRITES.
7	Critical trip lock bit – 0 = Critical trip is not locked and can be altered (this is the default). – 1 = Critical trip register settings cannot be altered. This bit is initially cleared. When set, this bit returns a logic '1' and remains locked until cleared by an internal power-on reset. These bits can be written to with a single WRITE, and do not require double WRITES.
8	Shutdown mode – 0 = TS is enabled (this is the default). – 1 = Shutdown TS when the shutdown, device, and A/D converter are disabled in order to save power. No event conditions will be asserted; when either of the lock bits is set, this bit cannot be altered until it is unlocked. However, it can be cleared at any time.
10:9	Hysteresis enable ⁽³⁾ (see Figure 8 and Table 10) – 00 = Hysteresis is disabled. – 01 = Hysteresis is enabled at 1.5°C. – 10 = Hysteresis is enabled at 3°C. – 11 = Hysteresis is enabled at 6°C.

1. The actual incident causing the event can be determined from the read temperature register. Interrupt events can be cleared by writing to the clear event bit (writing to this bit will have no effect on overall device functioning).
2. Writing to this register has no effect on overall device functioning in comparator mode. When read, this bit will always return a logic '0' result.
3. Hysteresis is also applied to the `EVENT` pin functionality. When either of the lock bits is set, these bits cannot be altered.

Figure 8. Hysteresis

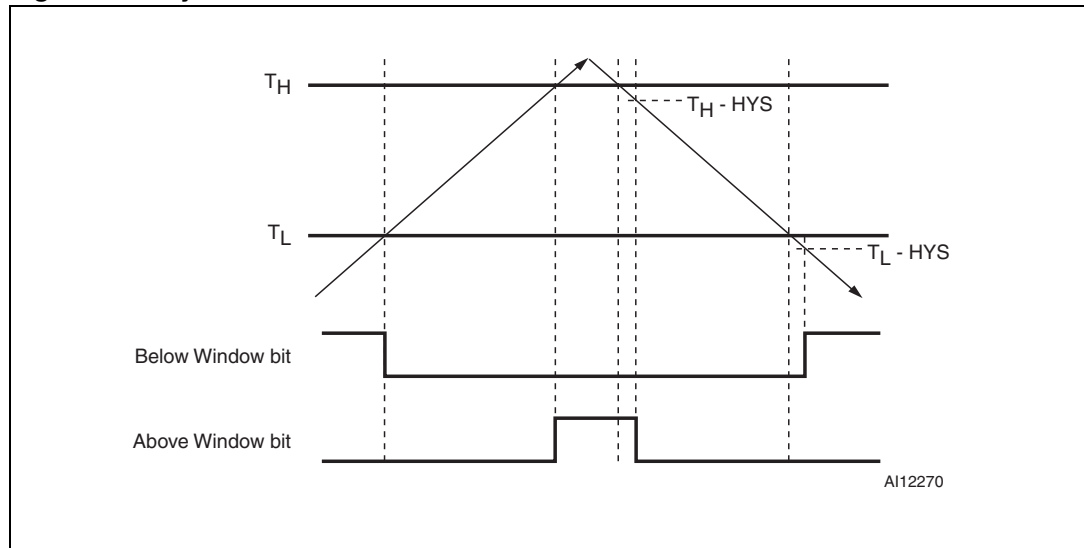

1. T_U = Value stored in the alarm temperature upper boundary trip register.
2. T_L = Value stored in the alarm temperature lower boundary trip register.
3. Hys = Absolute value of selected hysteresis.

Table 10. Hysteresis as applied to temperature movement

	Below alarm window bit		Above alarm window bit	
	Temperature slope	Temperature threshold	Temperature slope	Temperature threshold
Sets	Falling	$T_L - HYS$	Rising	T_H
Clears	Rising	T_L	Falling	$T_H - HYS$

4.2.5 Event output pin functionality

The $\overline{\text{EVENT}}$ pin is an open drain output and requires a pull-up resistor to V_{DD} on the system motherboard or incorporated into the master controller.

[Figure 9](#) shows the defined outputs of the $\overline{\text{EVENT}}$ correspondent to the temperature change.

The event outputs can be programmed to be configured as either a comparator output or as an interrupt. This is done by enabling the output control bit (bit 3) and setting the event mode bit (bit 0). The output pin polarity can also be specified as active-high or active-low by setting the event polarity bit (bit 1).

When the hysteresis bit (bits 10 and 9) is enabled, hysteresis may be used to sense temperature movement around trigger points. For example, when using the “above alarm window” bit (temperature register bit 14, see [Table 12 on page 22](#)) and hysteresis is set to 3°C, as the temperature rises, bit 14 is set (bit 14 = 1). The temperature is above the alarm window and the temperature register contains a value that is greater than the value set in the alarm temperature upper boundary register (see [Table 15 on page 23](#)).

If the temperature decreases, bit 14 will remain set until the measured temperature is less than or equal to the value in the alarm temperature upper boundary register minus 3°C (see [Figure 8 on page 19](#) and [Table 10 on page 19](#) for details).

Similarly, when using the “below alarm window” bit (temperature register bit 13, see [Table 12 on page 22](#)) will be set to '0'. The temperature is equal to or greater than the value set in the alarm temperature lower boundary register (see [Table 16 on page 24](#)). As the temperature decreases, bit 13 will be set to '1' when the value in the temperature register is less than the value in the alarm temperature lower boundary register minus 3°C (see [Figure 8 on page 19](#) and [Table 10 on page 19](#) for details).

The device will retain the previous state when entering the shutdown mode. If the device enters the shutdown mode while the $\overline{\text{EVENT}}$ pin is low, the shutdown current will increase due to the additional event output pull-down current.

If in interrupt mode and the temperature reaches the critical temperature, the $\overline{\text{EVENT}}$ pin remains asserted until the temperature drops below the critical limit minus hysteresis.

Note: Hysteresis is also applied to the $\overline{\text{EVENT}}$ pin functionality. When either of the lock bits (bits 6 or 7) is set, these bits cannot be altered.

Figure 9. Event output boundary timings

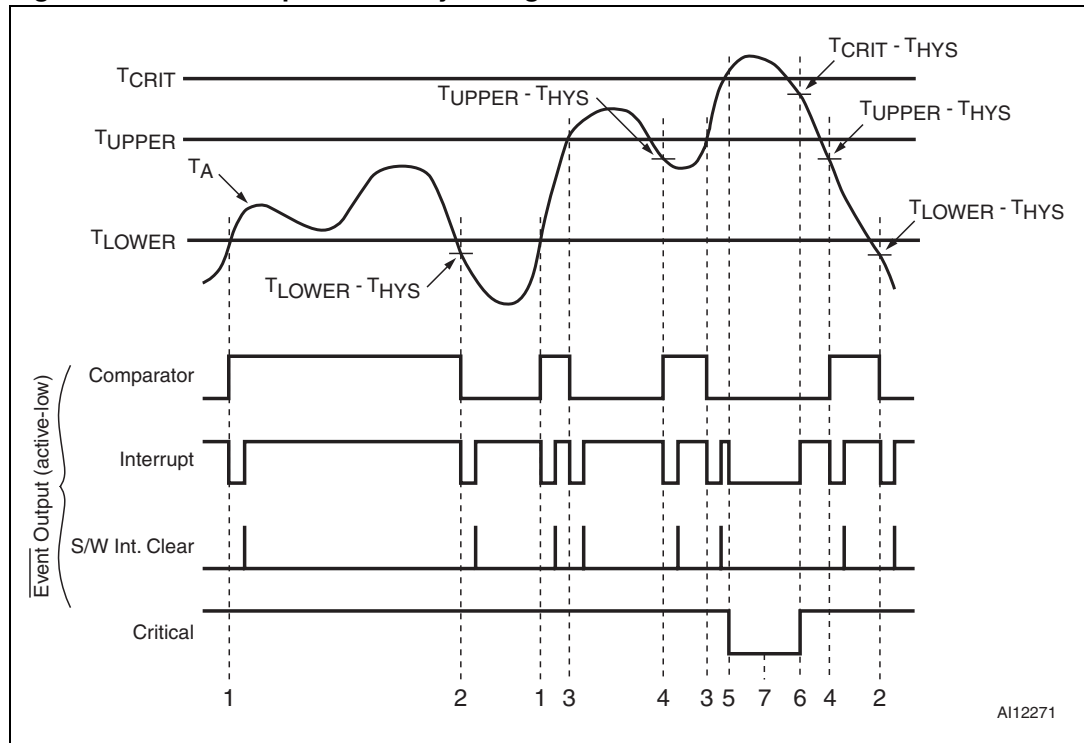

Table 11. Legend for Figure 9: Event output boundary timings

Note	Event output boundary conditions	Event output			T _A bits		
		Comparator	Interrupt	Critical	15	14	13
1	$T_A \geq T_{LOWER}$	H	L	H	0	0	0
2	$T_A \geq T_{LOWER} - T_{HYS}$	L	L	H	0	0	1
3	$T_A > T_{UPPER}$	L	L	H	0	1	0
4	$T_A \geq T_{UPPER} - T_{HYS}$	H	L	H	0	0	0
5	$T_A \geq T_{CRIT}$	L	L	L	1	1	0
6	$T_A < T_{CRIT} - T_{HYS}$	L	H	H	0	1	0
7	When $T_A \geq T_{CRIT}$ and $T_A < T_{CRIT} - T_{HYS}$, the event output is in comparator mode and bit 0 of the configuration register (interrupt mode) is ignored.						

Note: Systems that use the active high mode for event output must be wired point-to-point between the STTS424 and the sensing controller. Wire-OR configurations should not be used with active high EVENT since any device pulling the event output signal low will mask the other devices on the bus. Also note that the normal state of \overline{EVENT} in active high mode is a '0' which will constantly draw power through the pull-up resistor.

4.3 Temperature register (read-only)

This 16-bit, read-only register stores the temperature measured by the internal band gap TS as shown in [Table 12](#). The STTS424 meets the JEDEC JC42.4 mandatory 0.25°C resolution requirement. When reading this register, the MSBs (bit 15 to bit 8) are read first, and then the LSBs (bit 7 to bit 0) are read. The result is the current-sensed temperature. The data format is 2s complement with one LSB = 0.25°C. The MSB has a 128°C resolution.

The trip status bits represent the internal temperature trip detection, and are not affected by the status of the event or configuration bits (e.g. event output control or clear event). If neither of the above or below values are set (i.e. both are 0), then the temperature is exactly within the user-defined alarm window boundaries.

4.3.1 Temperature format

The 16-bit value used in the trip point set and temperature read-back registers is 2s complement, with the LSB equal to 0.0625°C (see [Table 13](#)). For example:

1. a value of 019Ch will represent 25.75°C,
2. a value of 07C0h will represent 124°C, and
3. a value of 1E74h will represent -24.75°C

The 0.0625°C resolution is optional. Supporting a resolution of at least 0.25°C is mandatory. All unused resolution bits will be set to zero. The MSB will have a resolution of 128°C. The STTS424 supports the 0.25°C/LSB only.

The upper 3 bits indicate trip status based on the current temperature, and are not affected by the event output status.

Table 12. Temperature register format

			Sign MSB										LSB			
Bit 15	Bit 14	Bit 13	Bit 12	Bit 11	Bit 10	Bit 9	Bit 8	Bit 7	Bit 6	Bit 5	Bit 4	Bit 3	Bit 2	Bit 1	Bit 0	
Above critical input ⁽¹⁾	Above alarm window ⁽¹⁾	Below alarm window ⁽¹⁾	Temperature										0	0		
Flag bits			Example hex value of 07C0 corresponds to 124°C (10-bit)													
0	0	0	0	0	1	1	1	1	1	0	0	0	0	0	0	07C0 h
Flag bits			Example hex value of 1C00 corresponds to -40°C (10-bit)													
0	0	0	1	1	1	0	1	1	0	0	0	0	0	0	0	1C00 h

1. See [Table 13](#) for explanation.

Table 13. Temperature register bit definitions

Bit	Definition with hysteresis = 0
13	Below (temperature) alarm window – 0 = Temperature is equal to or above the alarm window lower boundary temperature. – 1 = Temperature is below the alarm window.
14	Above (temperature) alarm window – 0 = Temperature is equal to or below the alarm window upper boundary temperature. – 1 = Temperature is below the alarm window.
15	Above critical trip – 0 = Temperature is below the critical temperature setting. – 1 = Temperature is equal to or above the critical temperature setting.

4.4 Temperature trip point registers (r/w)

The STTS424 alarm mode registers provide for 11-bit data in 2s compliment format. The data provides for one LSB = 0.25°C. All unused bits in these registers are read as '0'.

The STTS424 has three temperature trip point registers (see [Table 14](#)):

- Alarm temperature upper boundary threshold ([Table 15](#)),
- Alarm temperature lower boundary threshold ([Table 16](#)), and
- Critical temperature trip point value ([Table 17](#)).

Note: If the upper or lower boundary threshold values are being altered in-system, all interrupts should be turned off until a known state can be obtained to avoid superfluous interrupt activity.

Table 14. Temperature trip point register format

P2	P1	P0	Name	Register description	Width (bits)	Type (R/W)	Default state (POR)
0	1	0	UPPER	Alarm temperature upper boundary	16	R/W	00 00
0	1	1	LOWER	Alarm temperature lower boundary	16	R/W	00 00
1	0	0	CRITICAL	Critical temperature	16	R/W	00 00

Table 15. Alarm temperature upper boundary register format

			Sign MSB										LSB		
Bit 15	Bit 14	Bit 13	Bit 12	Bit 11	Bit 10	Bit 9	Bit 8	Bit 7	Bit 6	Bit 5	Bit 4	Bit 3	Bit 2	Bit 1	Bit 0
0	0	0	Alarm window upper boundary temperature											0	0

Table 16. Alarm temperature lower boundary register format

			Sign MSB											LSB		
Bit 15	Bit 14	Bit 13	Bit 12	Bit 11	Bit 10	Bit 9	Bit 8	Bit 7	Bit 6	Bit 5	Bit 4	Bit 3	Bit 2	Bit 1	Bit 0	
0	0	0	Alarm window lower boundary temperature										0	0		

Table 17. Critical temperature register format

			Sign MSB											LSB		
Bit 15	Bit 14	Bit 13	Bit 12	Bit 11	Bit 10	Bit 9	Bit 8	Bit 7	Bit 6	Bit 5	Bit 4	Bit 3	Bit 2	Bit 1	Bit 0	
0	0	0	Critical temperature trip point										0	0		

4.5 Manufacturer ID register (read-only)

The manufacturer's ID (programmed value 104Ah) in this register is the STMicroelectronics identification provided by the Peripheral Component Interconnect Special Interest Group (PCISIG).

Table 18. Manufacturer ID register format

Bit15	Bit14	Bit13	Bit12	Bit11	Bit10	Bit9	Bit8
0	0	0	1	0	0	0	0
Bit7	Bit6	Bit5	Bit4	Bit3	Bit2	Bit1	Bit0
0	1	0	0	1	0	1	0

4.6 Device ID and device revision ID register (read-only)

The device IDs and device revision IDs are maintained in this register. The register format is shown in [Table 19](#). The device IDs and device revision IDs are currently '0' and will be incremented whenever an update of the device is made.

Table 19. Device ID and device revision ID register format

Bit15	Bit14	Bit13	Bit12	Bit11	Bit10	Bit9	Bit8
0	0	0	0	0	0	0	1
Device ID							
Bit7	Bit6	Bit5	Bit4	Bit3	Bit2	Bit1	Bit0
0	0	0	0	0	0	0	1
Device revision ID							

5 Maximum ratings

Stressing the device above the ratings listed in the absolute maximum ratings table may cause permanent damage to the device. These are stress ratings only and operation of the device at these or any other conditions above those indicated in the operating sections of this specification is not implied. Exposure to absolute maximum rating conditions for extended periods may affect device reliability. Refer also to the STMicroelectronics SURE Program and other relevant quality documents.

Table 20. Absolute maximum ratings

Symbol	Parameter	Value	Unit
T_{STG}	Storage temperature	-60 to 150	°C
$T_{SLD}^{(1)}$	Lead solder temperature for 10 seconds	260	°C
V_{IO}	Input or output voltage - all pins	$V_{SS} - 0.3$ to $V_{DD} + 0.5$	V
V_{DD}	Supply voltage	$V_{SS} - 0.3$ to 6.5	V
V_{OUT}	Output voltage	$V_{DD} + 0.5$	V
I_O	Output current	10	mA
P_D	Power dissipation	320	mW
θ_{JA}	Thermal resistance	130	°C/W

1. Reflow at peak temperature of 255°C to 260°C for < 30 seconds (total thermal budget not to exceed 180°C for between 90 to 150 seconds).

6 DC and AC parameters

This section summarizes the operating measurement conditions, and the dc and ac characteristics of the device. The parameters in the DC and AC characteristics tables that follow, are derived from tests performed under the measurement conditions summarized in [Table 21: Operating and AC measurement conditions](#). Designers should check that the operating conditions in their circuit match the operating conditions when relying on the quoted parameters.

Table 21. Operating and AC measurement conditions

Parameter	Conditions	Unit
V _{DD} supply voltage - temperature sensor	2.7 to 3.6	V
Operating temperature	-40 to 125	°C
Input rise and fall times	≤ 5	ns
Input pulse voltages	0.2 to 0.8V _{DD}	V
Input and output timing reference voltages	0.3 to 0.7V _{DD}	V

Table 22. DC and AC characteristics - temperature sensor

Sym	Description	Test condition ⁽¹⁾	Min	Typ ⁽²⁾	Max	Unit
V _{DD}	Supply voltage		2.7	3.3	3.6	V
I _{DD}	V _{DD} supply current, active temperature conversions	SCL/SDA = V _{DD}		100	200	μA
	V _{DD} supply current, communication only (no conversions)		100 kHz		40	μA
			400 kHz		100	μA
I _{DD1}	Shutdown mode supply current, serial port inactive	DN package ⁽³⁾ at 125°C		1.0	3.0	μA
I _{SINK}	SMBUS output low sink current	SDA forced to 0.6 V	6			mA
I _{IH} , I _{IL}	Input/output leakage current				±2	μA
V _{POR}	Power on reset (POR) threshold	V _{DD} falling edge:		2.0		V
B-grade	Accuracy for corresponding range 2.7V ≤ V _{DD} ≤ 3.6V	+75°C < T _A < +95°C		±0.5	±1.0	°C
		+40°C < T _A < +125°C		±1.0	±2.0	°C
		-40°C < T _A < +125°C		±2.0	±3.0	°C
	Resolution	10-bit temperature data			0.25	°C/L SB
					10	bits
t _{CONV}	Conversion time	10-bit			125	ms
T _{HYS}	Hysteresis	Default value		500		mV
V _{OL1}	Low level voltage $\overline{\text{EVENT}}$	3.0 V ≤ V _{DD} ≤ 3.6 V; $\overline{\text{EVENT}}$; I _{OL} = 2.1 mA			0.4	V
SMBus/I²C interface						
V _{IH}	Input logic high	3.0 V ≤ V _{DD} ≤ 3.6 V; SCL, SDA	2.1			V
V _{IL}	Input logic low	3.0 V ≤ V _{DD} ≤ 3.6 V; SCL, SDA			0.8	V
C _{IN}	SMBus/I ² C Input capacitance			5		pF
f _{SCL}	SMBus/I ² C clock frequency		10		400	kHz
t _{TIMEOUT}	SMBus timeout		25		50	ms
V _{HV}	Allowable voltage on pin A0				10	V
L _{AO}	Leakage on pin A0 in overvoltage state			500		μA
V _{OL2}	Low level voltage SDA	I _{OL} = 6 mA			0.6	V

1. Guaranteed operating temperature for DN package: T_A = -40°C to 125°C; V_{DD} = 2.7 V to 3.6 V (except where noted).
2. Typical numbers taken at V_{DD} = 3.3 V, T_A = 25°C.
3. TDFN package max 0.80 mm height.

7 Package mechanical data

In order to meet environmental requirements, ST offers these devices in different grades of ECOPACK® packages, depending on their level of environmental compliance. ECOPACK® specifications, grade definitions and product status are available at: www.st.com. ECOPACK® is an ST trademark.

Figure 10. TDFN8 – 8-lead thin dual flat, no-lead (2 mm x 3 mm) package outline (DN)^(a)

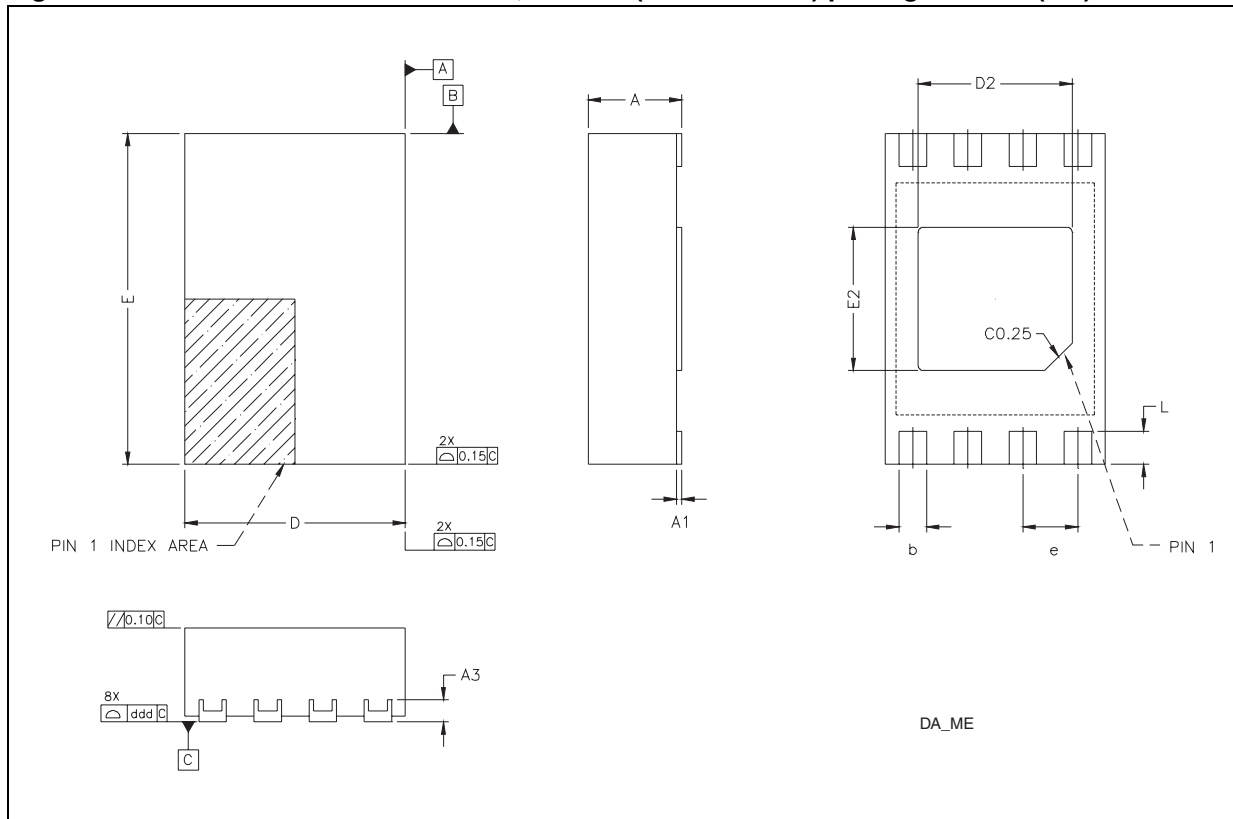

Table 23. TDFN8 – 8-lead thin dual flat, no-lead (2 mm x 3 mm) mechanical data (DN)⁽¹⁾

Sym	mm			inches		
	Min	Typ	Max	Min	Typ	Max
A	0.70	0.75	0.80	0.028	0.030	0.031
A1	0.00	0.00	0.05	0.000	0.000	0.002
A3		0.20			0.005	
b	0.20	0.25	0.30	0.008	0.010	0.012
D	1.95	2.00	2.05	0.075	0.078	0.079
D2	1.35	1.40	1.45	0.053	0.055	0.057
E	2.95	3.00	3.05	0.116	0.118	0.120
E2	1.25	1.30	1.35	0.049	0.051	0.053
e		0.50			0.020	
L	0.30	0.35	0.40	0.012	0.014	0.016
ddd			0.08			0.003

1. JEDEC MO-229, variation WCED-3 proposal

a. JEDEC MO-229, variation WCED-3 proposal

8 Part numbering

Table 24. Ordering information scheme

Example:	STTS424	B	DN	3	F
Device type	STTS424				
Grade		B: Maximum accuracy 75°C to 95°C = ± 1°C			
Package			DN = TDFN8 (2 mm x 3 mm) (0.80 mm max height)		
Temperature range				3 = -40°C to 125°C	
Shipping method					F = ECOPACK® package, tape & reel packing E = ECOPACK® package, tube packing

For other options, or for more information on any aspect of this device, please contact the ST sales office nearest you.

9 Package marking information

Figure 11. Device topside marking information (TDFN-8L)

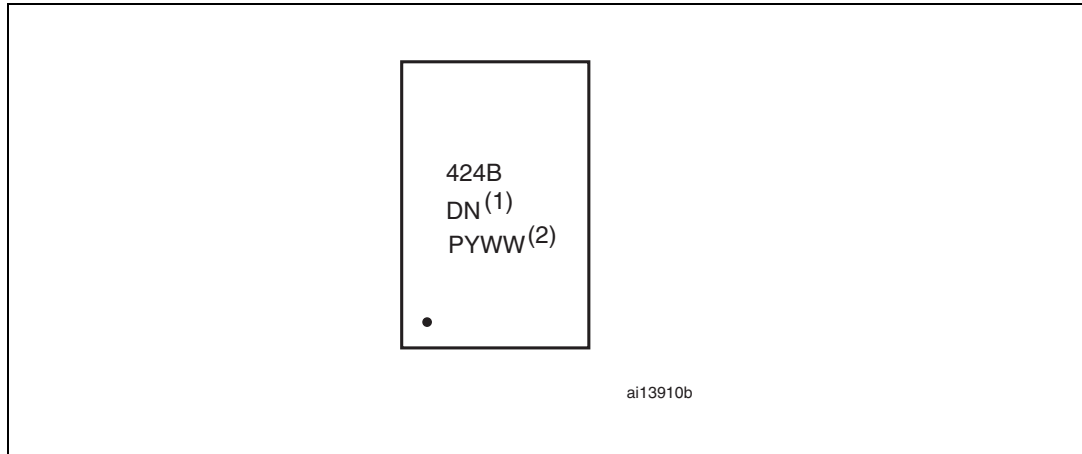

1. TDFN package identifier
DN = 0.80 mm (package height)
2. Traceability codes
P = Plant code
Y = Year
WW = Work Week

10 Landing pattern

The landing pattern recommendations for the TDFN package (DN) are shown in [Figure 12](#). The preferred implementation with wide corner pads enhances device centering during assembly, but a narrower option is defined for modules with tight routing requirements.

Figure 12. Landing pattern - TDFN package (DN)

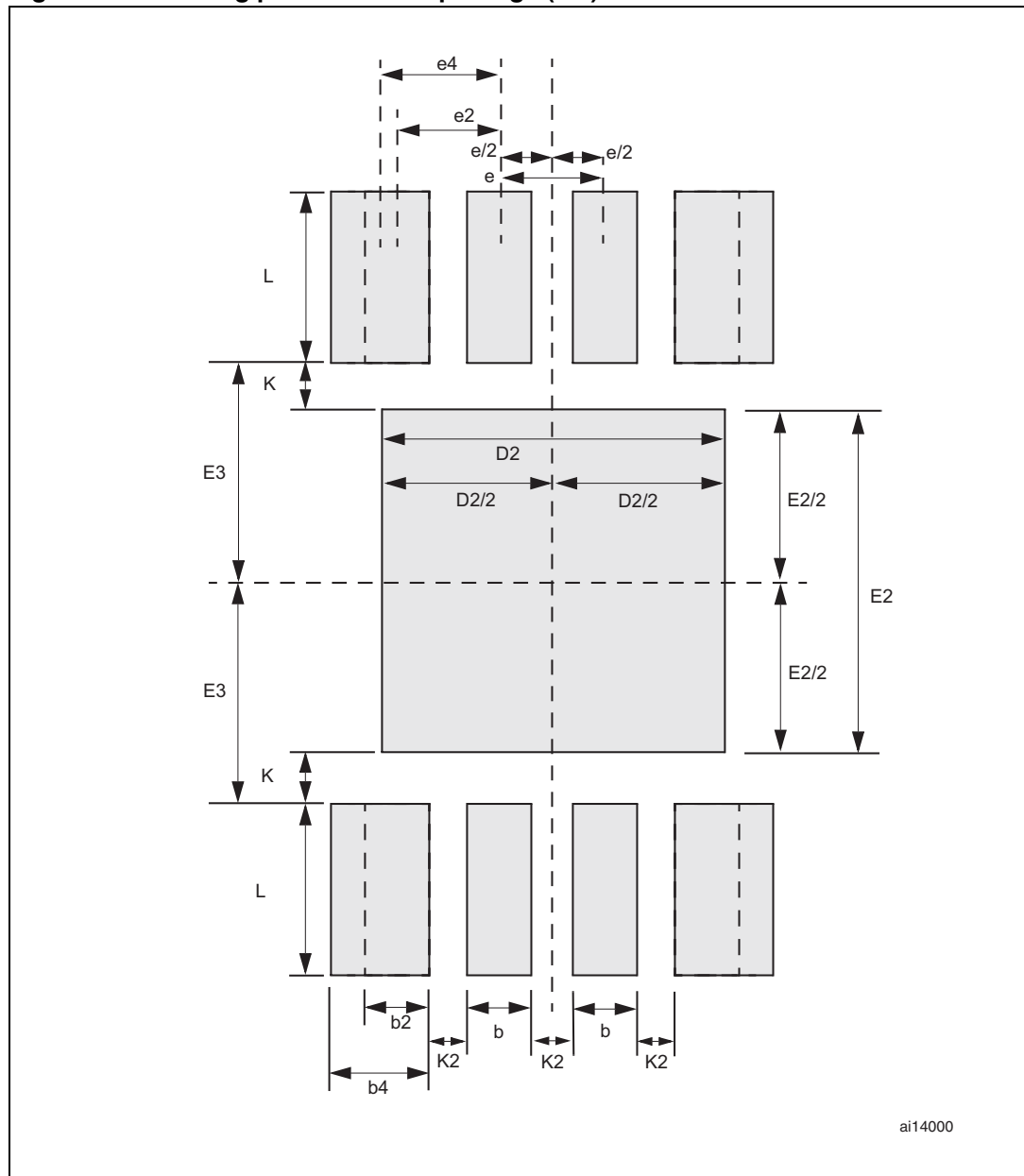

[Table 25](#) lists variations of landing pattern implementations, ranked as “preferred”, and minimum acceptable” based on the JEDEC proposal.

Table 25. Parameters for landing pattern - TDFN package (DN)

Parameter	Description	Dimension		
		Min	Nom	Max
D2	Heat paddle width	1.40	-	1.60
E2	Heat paddle height	1.40	-	1.60
E3	Heat paddle centerline to contact inner locus	1.00	-	-
L	Contact length	0.70	-	0.80
K	Heat paddle to contact keepout	0.20	-	-
K2	Contact to contact keepout	0.20	-	-
e	Contact centerline to contact centerline pitch for inner contacts	-	0.50	-
b	Contact width for inner contacts	0.25	-	0.30
e2	Landing pattern centerline to outer contact centerline, “minimum acceptable” option ⁽¹⁾	-	0.50	-
b2	Corner contact width, “minimum acceptable option” ⁽¹⁾	0.25	-	0.30
e4	Landing pattern centerline to outer contact centerline, “preferred” option ⁽²⁾	-	0.60	-
b4	Corner contact width, “preferred” option ⁽²⁾	0.45	-	0.50

1. Minimum acceptable option to be used when routing prevents preferred width contact.
2. Preferred option to be used when possible.

11 Revision history

Table 26. Document revision history

Date	Revision	Changes
17-Apr-2007	1	Initial release.
09-May-2007	2	Updated Table 3 , 5 , 6 , 7 , 22 , 23 , and 24 .
04-June-2007	3	Updated Table 22 .
02-Jul-2007	4	Added POR threshold values to Table 22 .
22-Oct-2008	5	Added TDFN package (cover page, Figure 10 , Table 23) and landing pattern recommendations (Figure 12 , Table 25); updated Section 1 , Section 4.3.1 ; Table 2 , 3 , 5 , 7 , 11 , 19 , 20 , 22 , 25 , and Figure 2 , 4 , 5 , 11 ; added Figure 6 ; removed all TSSOP8 and DFN8 package references throughout datasheet.
01-Apr-2009	6	Updated Features on cover page, Section 3.1 , Section 3.3 , Section 4.2.5 , Section 6 , Table 3 , 5 , 9 , 12 , 22 .

Please Read Carefully:

Information in this document is provided solely in connection with ST products. STMicroelectronics NV and its subsidiaries ("ST") reserve the right to make changes, corrections, modifications or improvements, to this document, and the products and services described herein at any time, without notice.

All ST products are sold pursuant to ST's terms and conditions of sale.

Purchasers are solely responsible for the choice, selection and use of the ST products and services described herein, and ST assumes no liability whatsoever relating to the choice, selection or use of the ST products and services described herein.

No license, express or implied, by estoppel or otherwise, to any intellectual property rights is granted under this document. If any part of this document refers to any third party products or services it shall not be deemed a license grant by ST for the use of such third party products or services, or any intellectual property contained therein or considered as a warranty covering the use in any manner whatsoever of such third party products or services or any intellectual property contained therein.

UNLESS OTHERWISE SET FORTH IN ST'S TERMS AND CONDITIONS OF SALE ST DISCLAIMS ANY EXPRESS OR IMPLIED WARRANTY WITH RESPECT TO THE USE AND/OR SALE OF ST PRODUCTS INCLUDING WITHOUT LIMITATION IMPLIED WARRANTIES OF MERCHANTABILITY, FITNESS FOR A PARTICULAR PURPOSE (AND THEIR EQUIVALENTS UNDER THE LAWS OF ANY JURISDICTION), OR INFRINGEMENT OF ANY PATENT, COPYRIGHT OR OTHER INTELLECTUAL PROPERTY RIGHT.

UNLESS EXPRESSLY APPROVED IN WRITING BY AN AUTHORIZED ST REPRESENTATIVE, ST PRODUCTS ARE NOT RECOMMENDED, AUTHORIZED OR WARRANTED FOR USE IN MILITARY, AIR CRAFT, SPACE, LIFE SAVING, OR LIFE SUSTAINING APPLICATIONS, NOR IN PRODUCTS OR SYSTEMS WHERE FAILURE OR MALFUNCTION MAY RESULT IN PERSONAL INJURY, DEATH, OR SEVERE PROPERTY OR ENVIRONMENTAL DAMAGE. ST PRODUCTS WHICH ARE NOT SPECIFIED AS "AUTOMOTIVE GRADE" MAY ONLY BE USED IN AUTOMOTIVE APPLICATIONS AT USER'S OWN RISK.

Resale of ST products with provisions different from the statements and/or technical features set forth in this document shall immediately void any warranty granted by ST for the ST product or service described herein and shall not create or extend in any manner whatsoever, any liability of ST.

ST and the ST logo are trademarks or registered trademarks of ST in various countries.

Information in this document supersedes and replaces all information previously supplied.

The ST logo is a registered trademark of STMicroelectronics. All other names are the property of their respective owners.

© 2009 STMicroelectronics - All rights reserved

STMicroelectronics group of companies

Australia - Belgium - Brazil - Canada - China - Czech Republic - Finland - France - Germany - Hong Kong - India - Israel - Italy - Japan - Malaysia - Malta - Morocco - Singapore - Spain - Sweden - Switzerland - United Kingdom - United States of America

www.st.com