



CLP30-200B1

ASD (Application Specific Devices)

Overvoltage and overcurrent protection for telecom line

Features

- Dual bidirectional protection device
- High peak pulse current:
 - $I_{PP} = 40\text{ A}$ (5/310 μs surge)
 - $I_{PP} = 30\text{ A}$ (10/1000 μs surge)
- Max. voltage at switching-on: 290 V
- Min. current at switching-off: 150 mA

Description

The CLP30-200B1 is designed to protect telecommunication equipment. It provides both a transient overvoltage protection and an overcurrent protection.

The external components (balanced resistors, ring relays contact, ...) needed by the CLP30-200B1 protection concept require very low power rating. This results in a very cost effective protection solution.

Main applications

Any telecom equipment submitted to transient overvoltages and lightning strikes such as :

- Analog and ISDN line cards
- PABX

Benefits

- Voltage and current controlled suppression
- Surface Mounting with SO-8 package
- Very low power rating of external components on line card: balanced resistors, ring relay, low voltage SLIC protection
- TRISILs™ are not subject to ageing and provide a fail safe mode in short circuit for a better level of protection. Trisils are used to ensure equipment meets various standards such as UL60950, IEC950 / CSA C22.2, UL1459 and FCC part 68. Trisils have UL94 V0 approved resin (Trisils are UL497B approved [file: E136224]).

TM: TRISIL is a trademark of STMicroelectronics

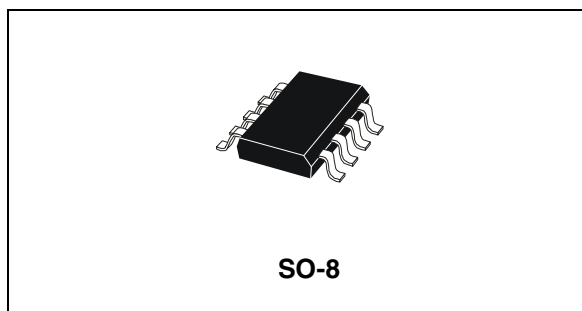

Order code

Part Number	Marking
CLP30-200B1RL	CLP30

Figure 1. CLP30-200B1 schematic diagram

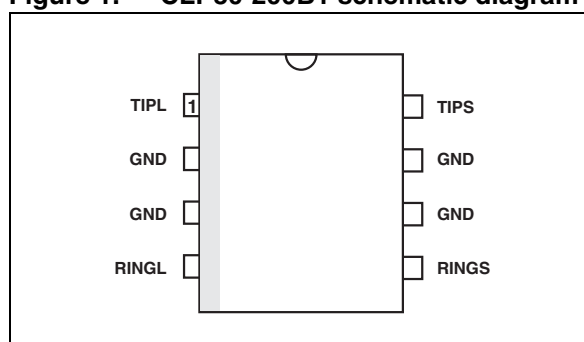
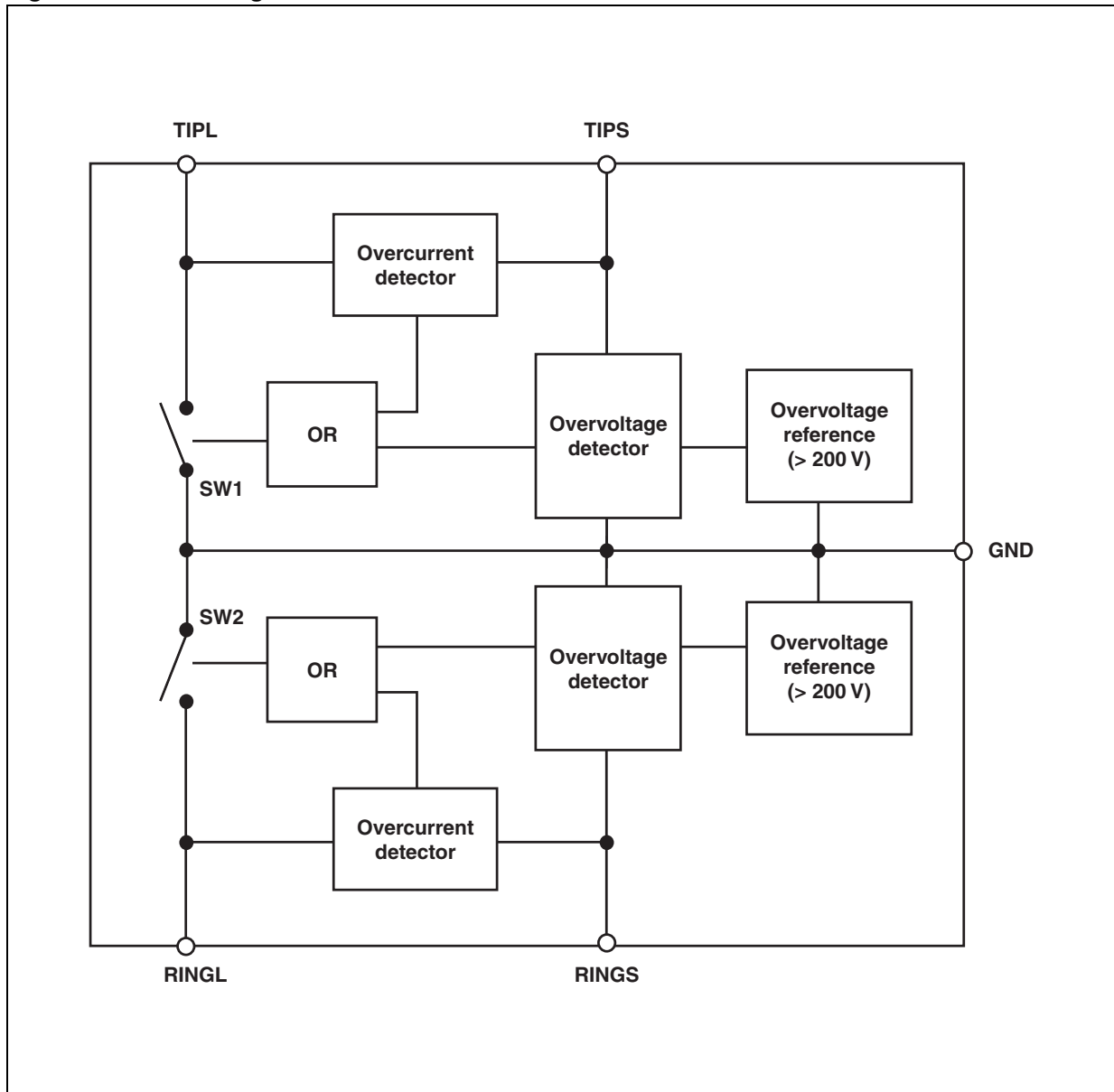

Figure 2. Block diagram



Pin	Symbol	Description
1	TIPL	TIP (line side)
2 / 3 / 6 / 7	GND	Ground
4	RINGL	RING (line side)
5	RINGS	RING (SLIC side)
8	TIPS	TIP (SLIC side)

1 Characteristics

Table 1. Standards compliance

Standard	Peak surge voltage (V)	Voltage waveform	Required peak current (A)	Current waveform	Minimum serial resistor to meet standard (Ω)
GR-1089 Core First level	2500	2/10 μ s	500	2/10 μ s	12
	1000	10/1000 μ s	100	10/1000 μ s	24
GR-1089 Core Second level	5000	2/10 μ s	500	2/10 μ s	24
GR-1089 Core Intra-building	1500	2/10 μ s	100	2/10 μ s	0
ITU-T-K20/K21	6000	10/700 μ s	150	5/310 μ s	110
	1500		37.5		0
ITU-T-K20 (IEC 61000-4-2)	8000	1/60 ns	ESD contact discharge		0
	15000		ESD air discharge		0
VDE0433	4000	10/700 μ s	100	5/310 μ s	60
	2000		50		10
VDE0878	4000	1.2/50 μ s	100	1/20 μ s	0
	2000		50		0
IEC61000-4-5	4000	10/700 μ s	100	5/310 μ s	60
	4000	1.2/50 μ s	100	8/20 μ s	0
FCC Part 68, lightning surge type A	1500	10/160 μ s	200	10/160 μ s	22.5
	800	10/560 μ s	100	10/560 μ s	15
FCC Part 68, lightning surge type B	1000	9/720 μ s	25	5/320 μ s	0

Table 2. Thermal resistance

Symbol	Paramete	Value	Unit
$R_{th(j-a)}$	Junction to ambient	170	$^{\circ}$ C/W

Table 3. Absolute maximum ratings ($R_{SENSE} = 3 \Omega$, $T_{amb} = 25^\circ C$)

Symbol	Parameter	Value	Unit
I_{PP}	Line to GND peak pulse current		
	– 10/1000 μs (open circuit voltage wave shape 10/1000 μs) – 5/310 μs (open circuit voltage wave shape 10/700 μs)	30 40	A
I_{TSM}	Non repetitive surge peak on-state current F = 50 Hz	$t_p = 10 \text{ ms}$	8.5
		$t_p = 200 \text{ ms}$	4.5
		$t_p = 1 \text{ s}$	3.5
T_{stg} T_j	Storage temperature range	-40 to +150	$^\circ C$
	Maximum junction temperature	150	
T_L	Lead temperature for soldering during 10 s.	260	$^\circ C$

Table 4. Electrical characteristics ($R_{SENSE} = 3 \Omega$, $T_{amb} = 25^\circ C$)

Symbol	Parameter	Test conditions	Min	Max	Unit
I_{LGL}	Line to GND leakage current	$V_{LG} = 200 \text{ V}$ Measured between TIPL (or RINGL) and GND		10	μA
V_{LG}	Line to GND operating voltage			200	V
V_{SWON}	Line to GND voltage at SW1 or SW2 switching-on	Measured at 50 Hz between TIPL (or RINGL) and GND, one cycle		290	V
I_{SWOFF}	Line to GND negative current at SW1 or SW2 switching-off	Refer to test circuit fig 9	150		mA
I_{SWON}	Line current at SW1 or SW2 switching-on	Positive surge	220	320	mA
		Negative surge	280	380	
C	Line to GND capacitance	$V_{LG} = 0 \text{ V}$ $V_{OSC} = 200 \text{ mV}_{RMS}$ F = 1MHz		100	pF

Figure 3. Test circuit for I_{SWOFF} parameter: GO-NO GO test

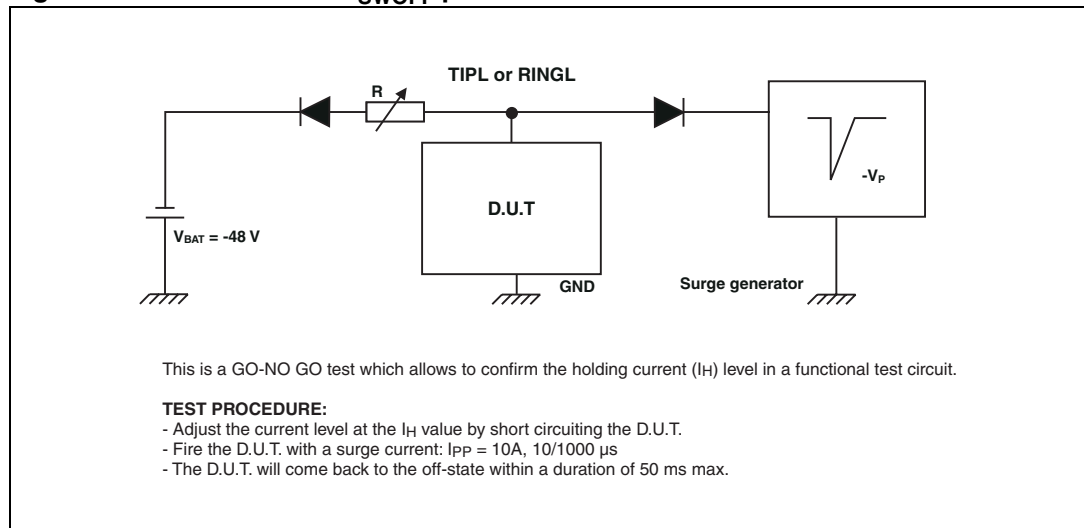

Figure 4. Typical variation of switching-on current (positive or negative) versus R_{SENSE} resistor and junction temperature (see test condition figure 6)

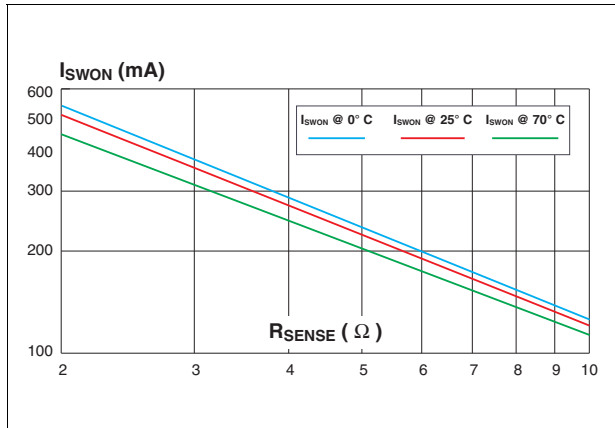

Figure 5. Variation of switching-on current versus R_{SENSE} at 25°C

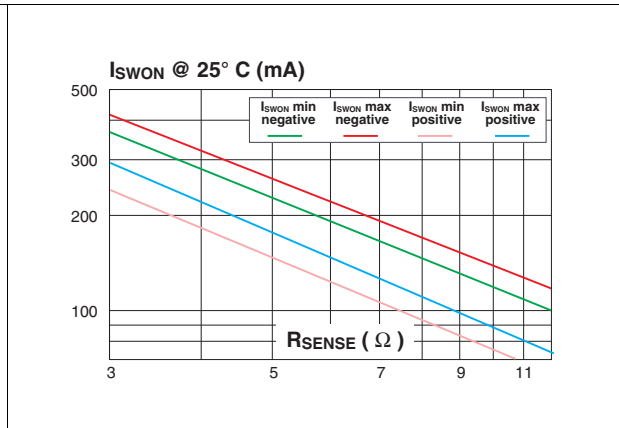

Figure 6. I_{SWON} MEASUREMENT:

- $I_{SWON} = I_1$ when the CLP30-200B1 switches on (I_1 is progressively increased using R)
- Both TIP and RING sides of the CLP30-200B1 are checked
- $R_L = 10 \Omega$

Figure 7. Relative variation of switching-off current versus junction temperature (for R_{SENSE} between 3 and 10 Ω)

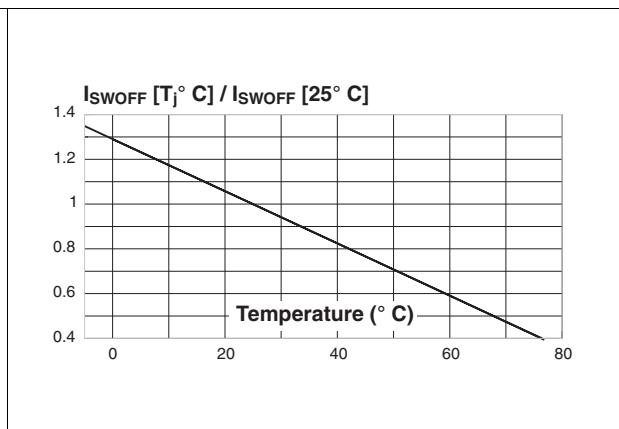
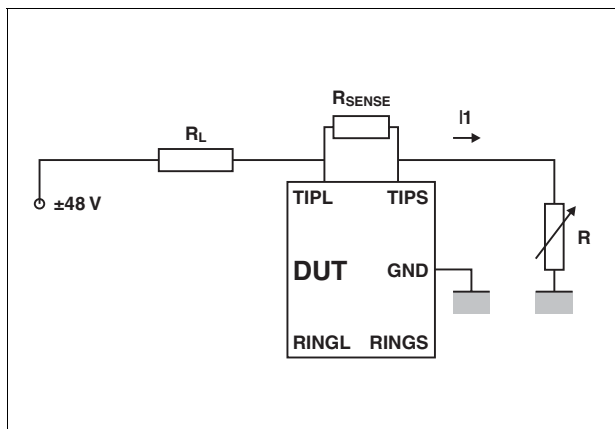

Figure 8. Relative variation of switching-off current versus R_{SENSE} (between 3 and 10 Ω)

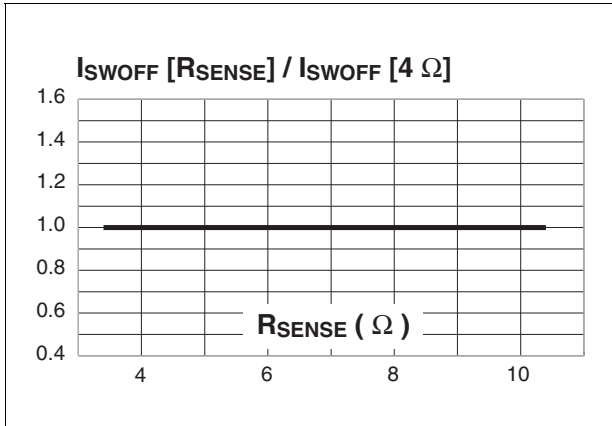

Figure 9. Relative variation of switching-on voltage versus dV/dt with an external resistor of 3 Ω

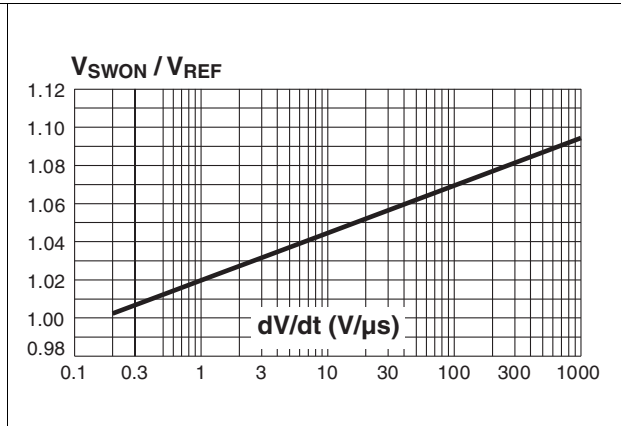

Figure 10. Relative variation of internal reference voltage versus junction temperature ($I_{LG} = 1 \text{ mA}$)

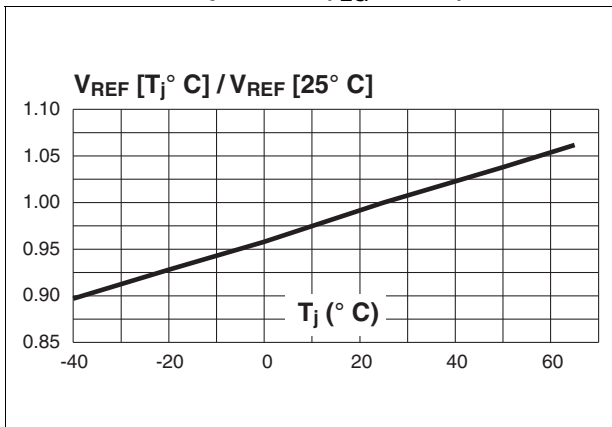

Figure 11. Capacitance (TIP/GND) versus applied voltage (typical values)

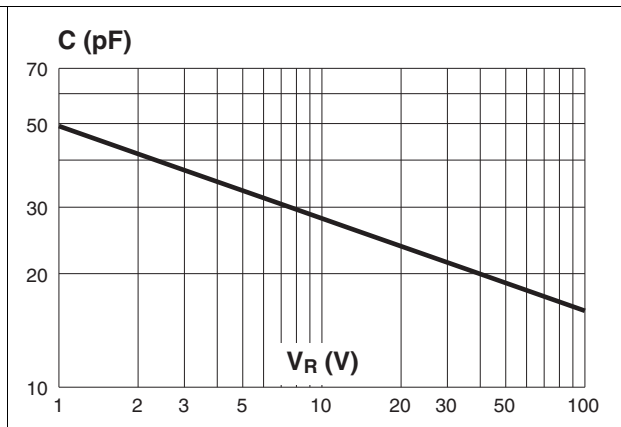
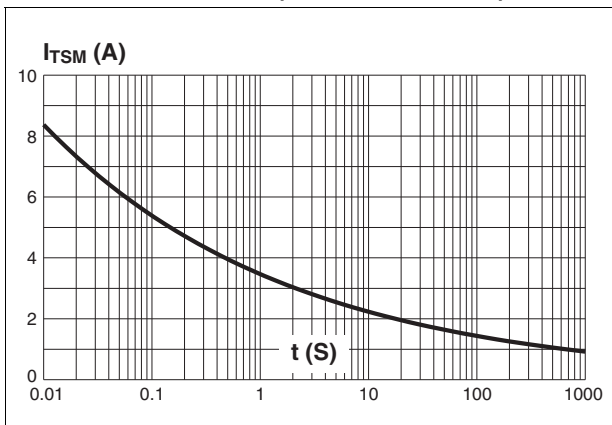

Figure 12. Surge peak current versus overload duration (maximum values)



2 Technical information

2.1 Introduction

The aim of this section is to show the behavior of our new telecom line protection device.

Figure 13. Subscriber line protection topology

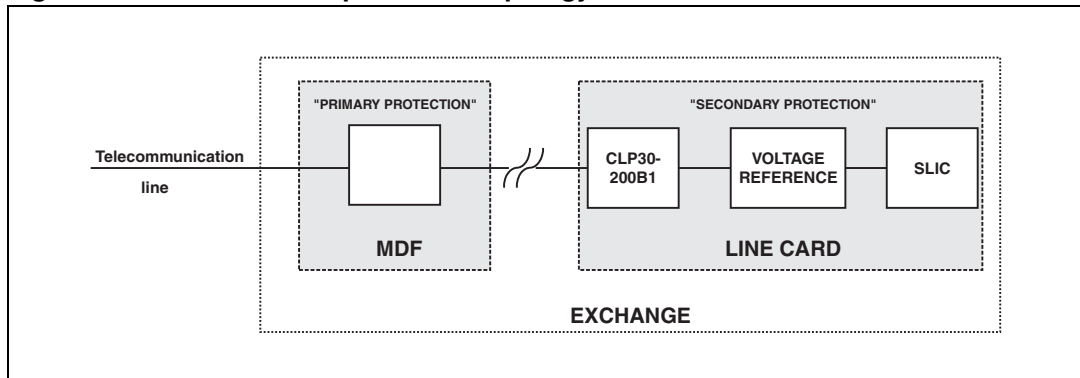

Figure 13. is a simplified block diagram of a subscriber line protection that is mainly used so far. This shows two different things:

- A “primary protection” located on the Main Distribution Frame (MDF) eliminates coarsely the high energy environmental disturbances (lightning transients and AC power mains disturbances) for which the ITU-T-K20 requires a 4 kV 10/700 μ s test. This can be assumed either by gas-tubes or silicon protection such as the TLPxxM.
- A “secondary protection” located on the line card eliminates finely the remaining transients that have not been totally suppressed by the first stage. The ITU-T-K20 requires a 1 kV 10/700 μ s test. At this stage, the protection is managed by the CLP30-200B1.

The explanations which follow are basically covering the line card application.

2.2 STMicroelectronics CLP30-200B1 concept

2.2.1 Evolution of the SLIC protection

Over the years, the performances of the SLICs considerably increased and therefore the need of the protection has also evolved.

The CLP30-200B1 is especially designed for the protection of this new generation of SLIC. For this, it is based on both overvoltage and overcurrent protection modes.

Figure 14. Line card protection

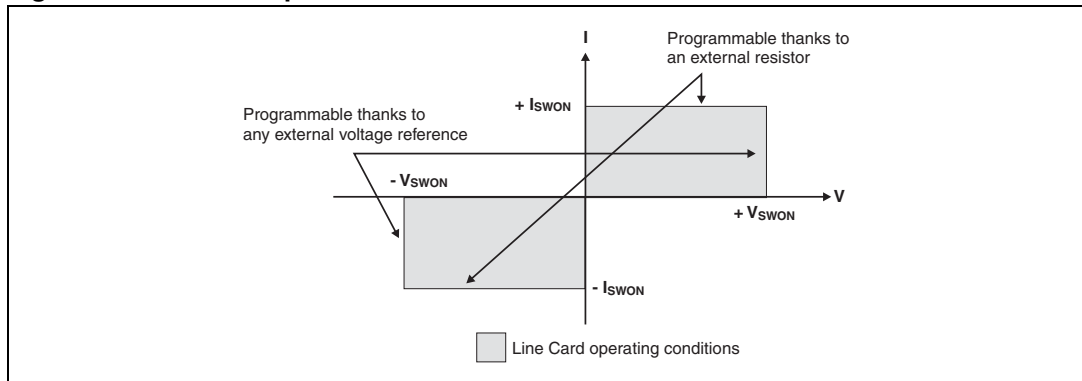
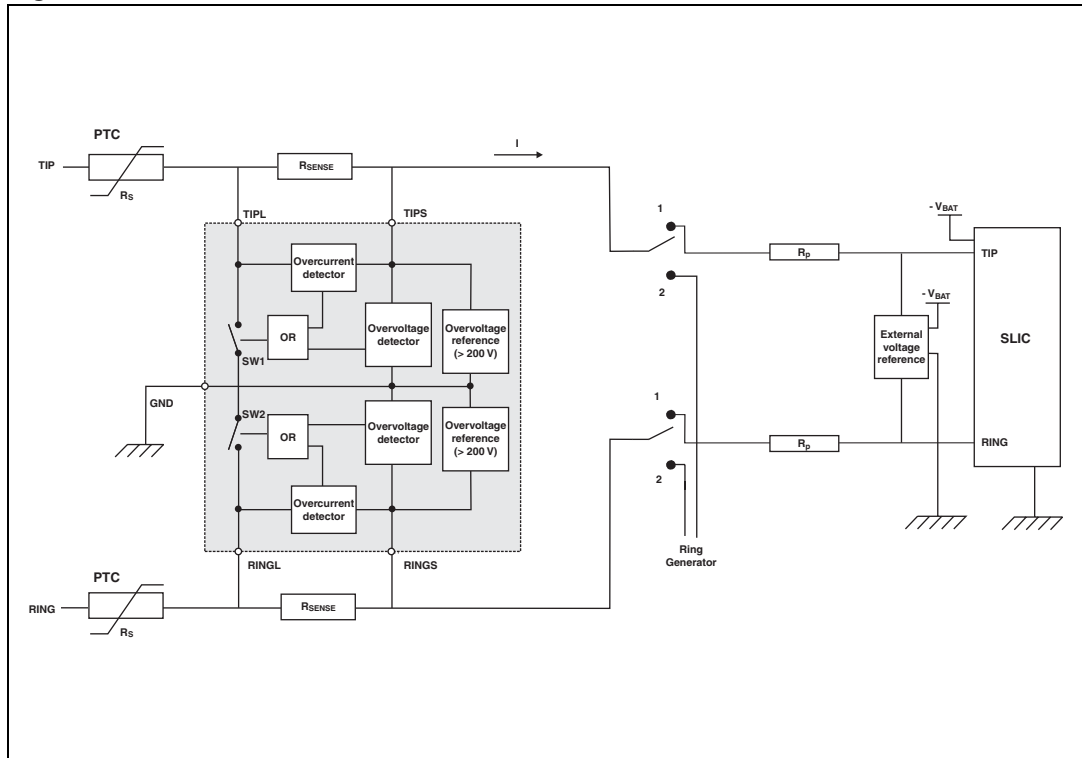

Figure 14. summarises the performance of the CLP30-200B1 which basically holds the SLIC inside its correct voltage and current values.

2.2.2 Application circuit

Figure 15. CLP30-200B1 in line card



The Figure 15. above shows the topology of a protected analog subscriber line at the line card side.

- A first stage based on CLP30-200B1 manages the high power issued from the external surges. When used in ringing mode, the CLP30-200B1 operates in voltage mode and provides a symmetrical and bidirectional overvoltage protection above 200 V on both TIP and RING lines. When used in speech mode, the CLP30-200B1 operates in current mode and the activation current of the CLP30-200B1 is adjusted by R_{SENSE} .

- A second stage which is the external voltage reference device defines the firing threshold voltage during the speech mode and also assumes a residual power overvoltage suppression. This stage can be either a fixed or programmable device such as LCP1511D.

2.2.3 Ringing mode

Figure 16. Switching by voltage during ringing mode

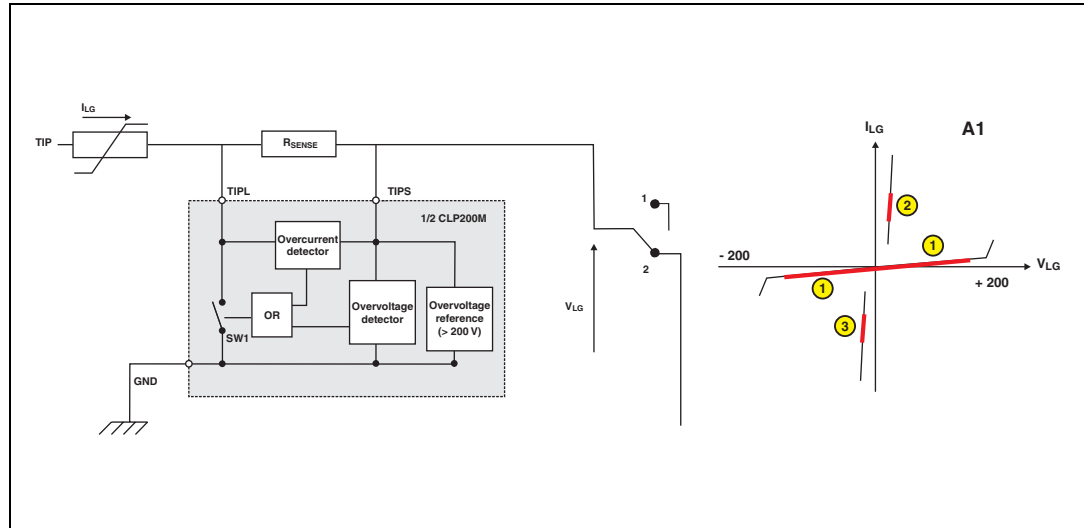

In ringing mode (ring relay in position 2), the only protection device involved is the CLP30-200B1.

In normal conditions, the CLP30-200B1 operates in region 1 of **A1** curve, and is idle.

If an overvoltage occurring between TIP (or RING) and GND reaches the internal overvoltage reference (+/- 200 V), the CLP30-200B1 acts and the line is short-circuited to GND. At this time the operating point moves **to region 2** for positive surges (**region 3** for negative surges). Once the surge current disappears, the device returns to its initial state (**region 1**).

For surges occurring between TIP and RING, the CLP30-200B1 acts in the same way. This means that the CLP30-200B1 ensures a tripolar protection.

When used alone, the CLP30-200B1 acts at the internal overvoltage reference level (+/- 200V). Furthermore, it is possible to adjust this threshold level to a lower voltage by using up to 4 fixed external voltage reference (V_{Z1} to V_{Z4}) (see [Figure 17](#)).

Figure 17. Method to adjust the reference voltage

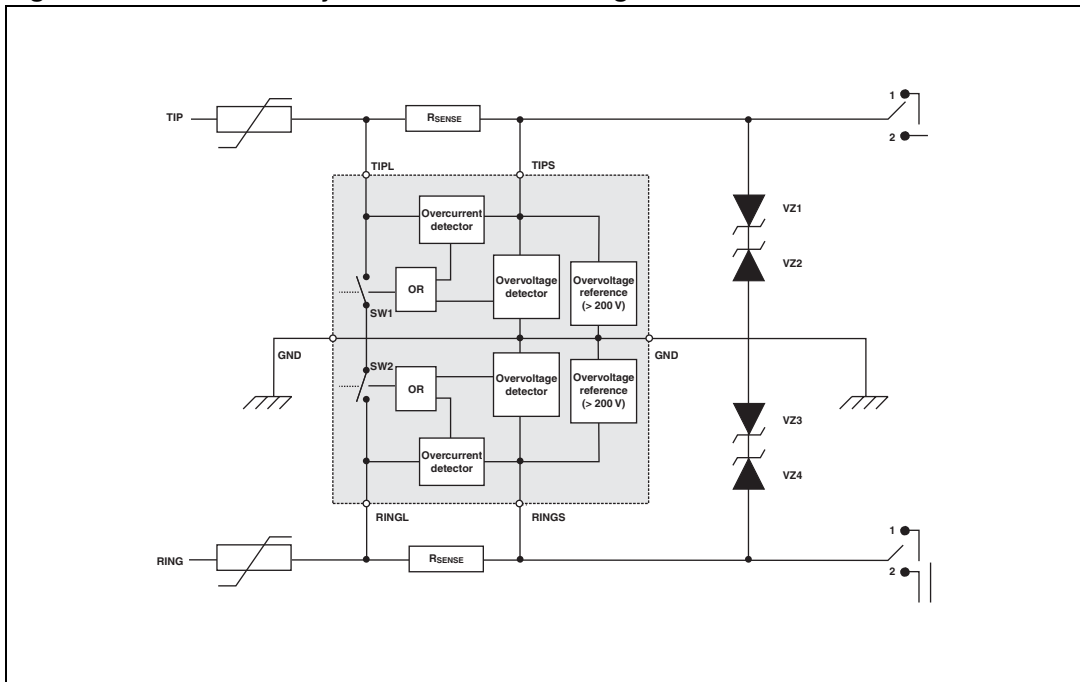

2.2.4 Speech mode

Figure 18. Switching by current during speech mode

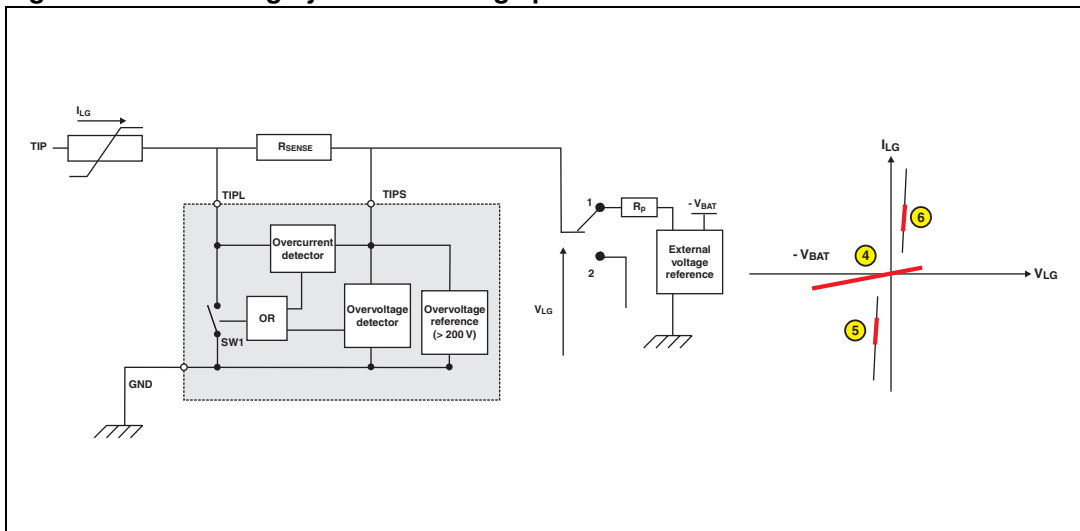

In speech mode (ring relay in position 1), the protection is provided by the combination of both CLP30-200B1 and the external voltage reference device (for example LCP1511D).

In normal conditions, the working point of this circuit is located in **region 4** of **A2** curve: the CLP30-200B1 is idle.

When a surge occurs on the line, the external voltage reference device clamps at GND or $-V_{BAT}$ respectively for positive and negative surges. This generates a current which is detected by R_{SENSE} and causes the protection to act: the line is short-circuited to GND. The operating point moves to **region 6** for positive surges or **region 5** for negative surges.

Once the surge current falls below the switching-off current I_{SWOFF} , the CLP30-200B1 returns to its initial state (**region 4**).

Furthermore, the CLP30-200B1 switches when an overvoltage, either positive or negative, occurs either:

- simultaneously on both TIP and RING lines versus GND
- between TIP and RING
- on TIP (or RING) versus GND

The choice of the switching-on current is function of the R_{SENSE} resistors.

Figure 19. Switching-on current versus R_{SENSE} : relative variation of I_{SWON} versus R_{SENSE} at various temperature

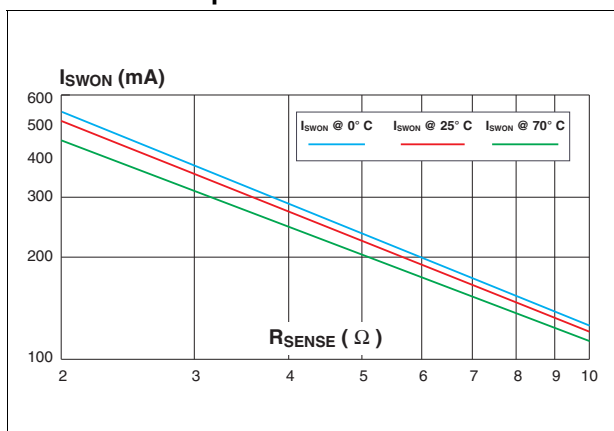
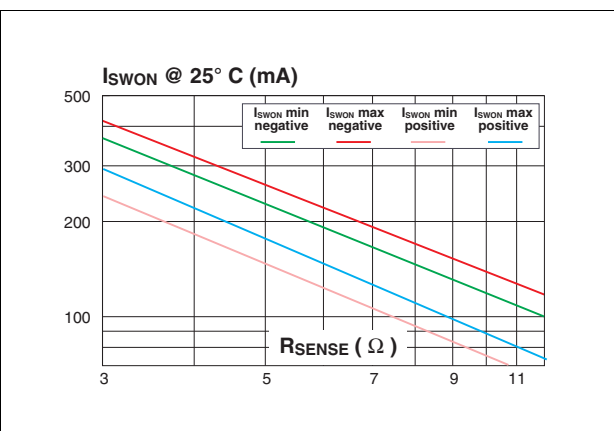

Figure 20. Switching-on current versus R_{SENSE} : relative variation of I_{SWON} versus R_{SENSE} at $T_{amb} = 25^\circ C$



This current (typically above 150 mA) should not activate the protection device CLP30-200B1.

Therefore the level of activation is to be chosen just below this limit (typically 200 mA). This level is adjusted through R_{SENSE} .

Figures 7a and 7b enable the designers to choose the right R_{SENSE} value.

Example

The choice of $R_{SENSE} = 3 \Omega$ ensures a negative triggering of -280 mA min and -380 mA maximum.

In this case, the positive triggering will be 220 mA min and 320 mA max.

Thanks to the CLP30-200B1 topology, the surge current in the line is reduced after it.

Because the remaining surge energy is low, the power ratings of R_p the relay contacts and the external voltage reference device may be kept low.

This results in a significant cost reduction for the whole system.

3 Ordering information scheme

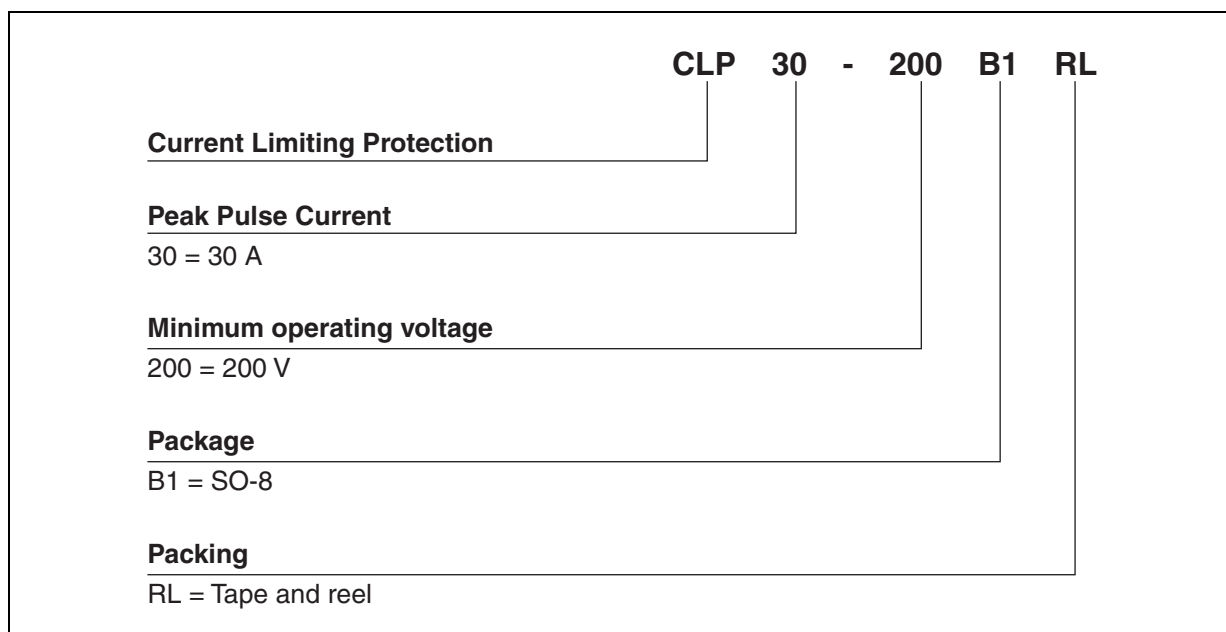

4 Package information

Table 5. SO-8 dimensions

Ref.	Dimensions					
	Millimeters			Inches		
	Min.	Typ.	Max.	Min.	Typ.	Max.
A			1.75			0.069
A1	0.1		0.25	0.004		0.010
A2	1.25			0.049		
b	0.28		0.48	0.011		0.019
C	0.17		0.23	0.007		0.009
D	4.80	4.90	5.00	0.189	0.193	0.197
E	5.80	6.00	6.20	0.228	0.236	0.244
E1	3.80	3.90	4.00	0.150	0.154	0.157
e		1.27			0.050	
h	0.25		0.50	0.010		0.020
L	0.40		1.27	0.016		0.050
L1		1.04			0.041	
k°	0		8	0		8
ccc			0.10			0.004

Figure 21. SO-8 footprint (dimensions in mm)

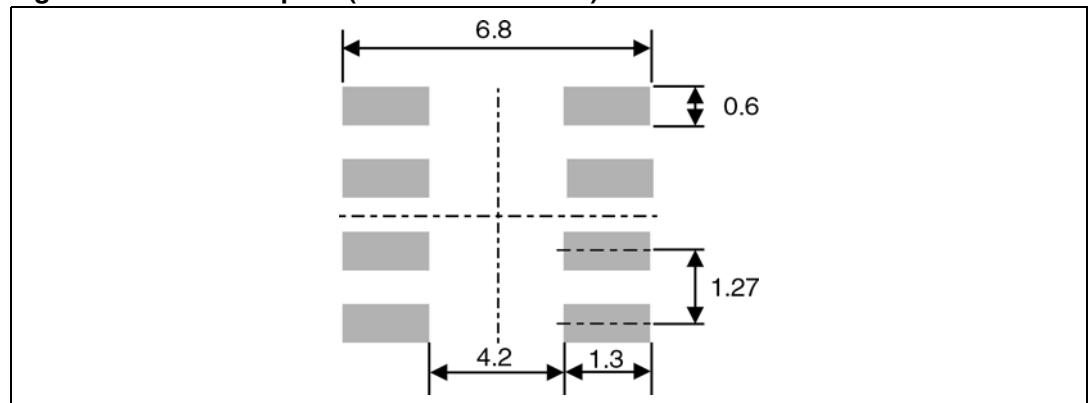

5 Ordering information

Part Number	Marking	Package	Weight	Base qty	Delivery mode
CLP30-200B1RL	CLP30	SO-8	0.11 g	2500	Tape and reel

6 Revision history

Date	Revision	Description of Changes
28-Aug-2006	1	First issue.

Please Read Carefully:

Information in this document is provided solely in connection with ST products. STMicroelectronics NV and its subsidiaries ("ST") reserve the right to make changes, corrections, modifications or improvements, to this document, and the products and services described herein at any time, without notice.

All ST products are sold pursuant to ST's terms and conditions of sale.

Purchasers are solely responsible for the choice, selection and use of the ST products and services described herein, and ST assumes no liability whatsoever relating to the choice, selection or use of the ST products and services described herein.

No license, express or implied, by estoppel or otherwise, to any intellectual property rights is granted under this document. If any part of this document refers to any third party products or services it shall not be deemed a license grant by ST for the use of such third party products or services, or any intellectual property contained therein or considered as a warranty covering the use in any manner whatsoever of such third party products or services or any intellectual property contained therein.

UNLESS OTHERWISE SET FORTH IN ST'S TERMS AND CONDITIONS OF SALE ST DISCLAIMS ANY EXPRESS OR IMPLIED WARRANTY WITH RESPECT TO THE USE AND/OR SALE OF ST PRODUCTS INCLUDING WITHOUT LIMITATION IMPLIED WARRANTIES OF MERCHANTABILITY, FITNESS FOR A PARTICULAR PURPOSE (AND THEIR EQUIVALENTS UNDER THE LAWS OF ANY JURISDICTION), OR INFRINGEMENT OF ANY PATENT, COPYRIGHT OR OTHER INTELLECTUAL PROPERTY RIGHT.

UNLESS EXPRESSLY APPROVED IN WRITING BY AN AUTHORIZED ST REPRESENTATIVE, ST PRODUCTS ARE NOT RECOMMENDED, AUTHORIZED OR WARRANTED FOR USE IN MILITARY, AIR CRAFT, SPACE, LIFE SAVING, OR LIFE SUSTAINING APPLICATIONS, NOR IN PRODUCTS OR SYSTEMS WHERE FAILURE OR MALFUNCTION MAY RESULT IN PERSONAL INJURY, DEATH, OR SEVERE PROPERTY OR ENVIRONMENTAL DAMAGE. ST PRODUCTS WHICH ARE NOT SPECIFIED AS "AUTOMOTIVE GRADE" MAY ONLY BE USED IN AUTOMOTIVE APPLICATIONS AT USER'S OWN RISK.

Resale of ST products with provisions different from the statements and/or technical features set forth in this document shall immediately void any warranty granted by ST for the ST product or service described herein and shall not create or extend in any manner whatsoever, any liability of ST.

ST and the ST logo are trademarks or registered trademarks of ST in various countries.

Information in this document supersedes and replaces all information previously supplied.

The ST logo is a registered trademark of STMicroelectronics. All other names are the property of their respective owners.

© 2006 STMicroelectronics - All rights reserved

STMicroelectronics group of companies

Australia - Belgium - Brazil - Canada - China - Czech Republic - Finland - France - Germany - Hong Kong - India - Israel - Italy - Japan - Malaysia - Malta - Morocco - Singapore - Spain - Sweden - Switzerland - United Kingdom - United States of America

www.st.com

