

**Transil™, transient voltage suppressor****Features**

- Stand-off voltage 16V
- Unidirectional device
- Low clamping factor  $V_{CL}/V_{BR}$
- Fast response time
- Very thin package: 0.65 mm

**Complies with the following standards**

- IEC 61000-4-2 Level 4
  - 15 kV (air discharge)
  - 8 kV (contact discharge)

**Description**

The ESDA18-1F2 is a single line Transil diode designed specifically for the protection of integrated circuits into portable equipment and miniaturized electronics devices subject to ESD and EOS transient overvoltages.

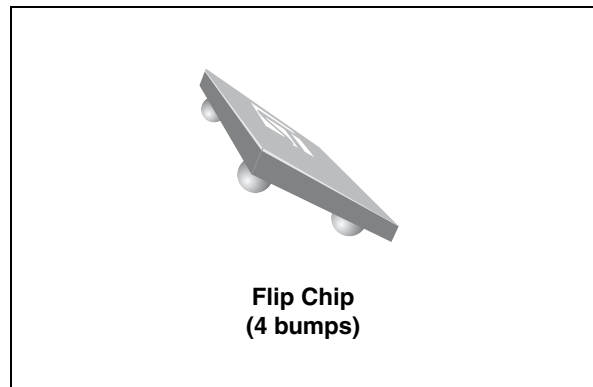
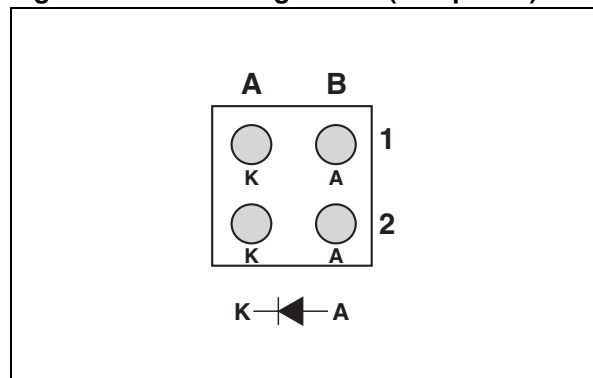
**Figure 1. Pin configuration (bump side)**

**TM:** Transil is a trademark of STMicroelectronics.

# 1 Characteristics

**Table 1. Absolute ratings (limiting value, per diode)**

Symbol	Parameter and test conditions	Value	Unit	
P <sub>PP</sub>	Peak pulse power dissipation 10 / 1000 μs pulse	100	W	
	Peak pulse power dissipation 8 / 20 μs pulse	700		
I <sub>FSM</sub>	Non repetitive surge peak forward current	t <sub>p</sub> =10 ms T <sub>j</sub> initial = T <sub>amb</sub>	8	A
T <sub>j</sub>	Maximum operating junction temperature		125	°C
T <sub>stg</sub>	Storage temperature range		- 65 to + 175	°C

**Table 2. Electrical characteristics (T<sub>amb</sub> = 25 °C)**

Symbol	Parameter									
V <sub>BR</sub>	Breakdown voltage									
I <sub>RM</sub>	Leakage current									
V <sub>RM</sub>	Stand-off voltage									
V <sub>CL</sub>	Clamping voltage									
R <sub>d</sub>	Dynamic impedance									
I <sub>PP</sub>	Peak pulse current									
C	Capacitance									
Order number	V <sub>BR</sub>		I <sub>R</sub>	I <sub>RM</sub>	V <sub>RM</sub>	V <sub>CL</sub>	I <sub>PP</sub> <sup>(1)</sup>	V <sub>F</sub> <sup>(2)</sup>	αT	C
	min.	max.								
	V	V	mA	μA	V	V	A	V	10 <sup>-4</sup> /°C	pF
ESDA18-1F2	16	18	1	0.5	10	20	1	1.3	8.5	230

- 8 / 20 μs pulse waveform.
- A DC current is not recommended for more than 5 sec. Even if Transil failure mode is short circuit the bumps could exceed melting temperature and the component disassembled from the board.

**Figure 2. Relative variation of peak pulse power versus initial junction temperature**

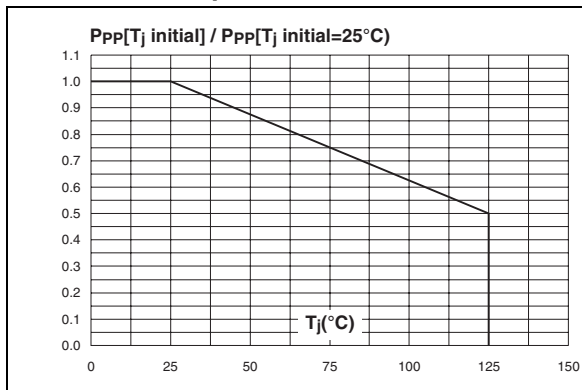

**Figure 3. Peak pulse power versus exponential pulse duration**

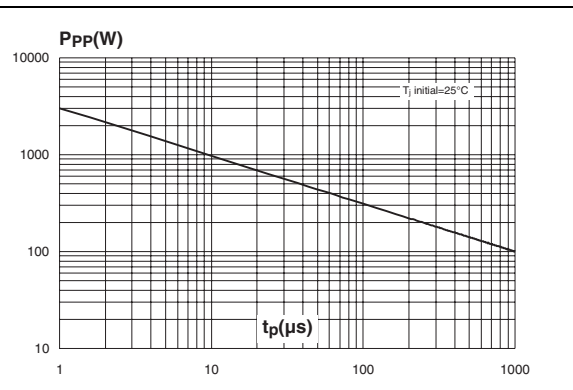

**Figure 4. Clamping voltage versus peak pulse current (typical values, exponential waveform)**

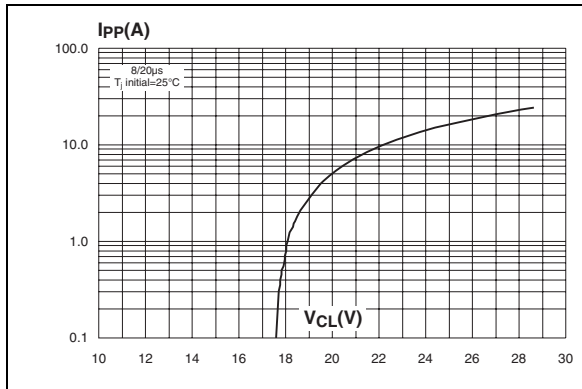

**Figure 5. Forward voltage drop versus peak forward current (typical values)**

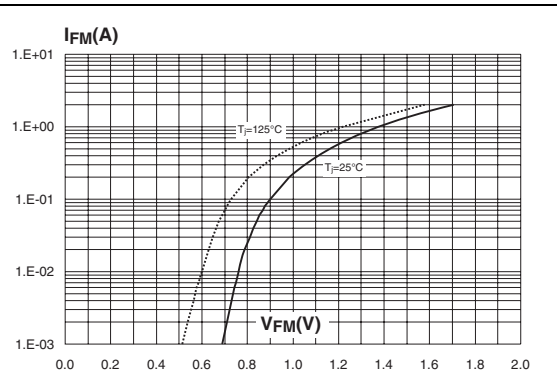

**Figure 6. Junction capacitance versus reverse voltage applied (typical values)**

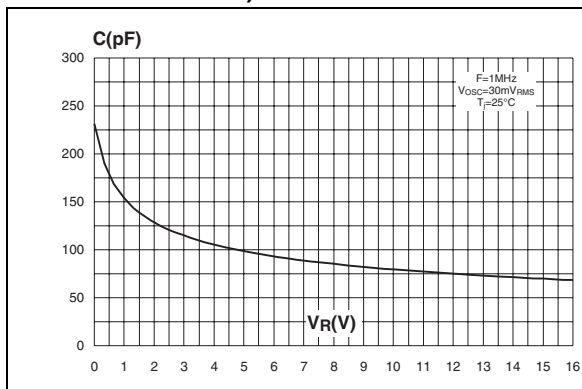

**Figure 7. Relative variation of leakage current versus junction temperature (typical values)**

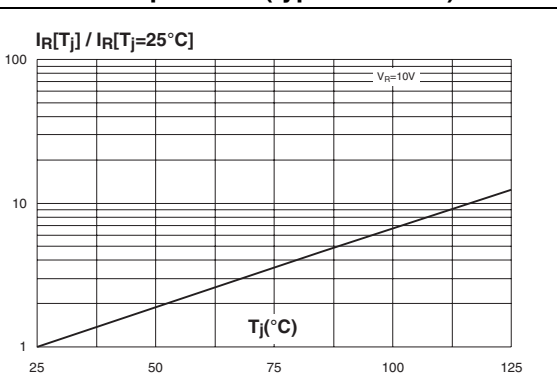

## 2 Application information

One major point is that the ESDA18-1F2 has to ensure the safety during reverse battery operation. Indeed, during this operation the device must clamp the DC reverse voltage below 1.3 V @ 0.85 A (max current). Thus reverse battery operation has been simulated by inverting the polarity of the Transil (please see figures 8 and 9)

**Figure 8. Reverse battery operation setup**

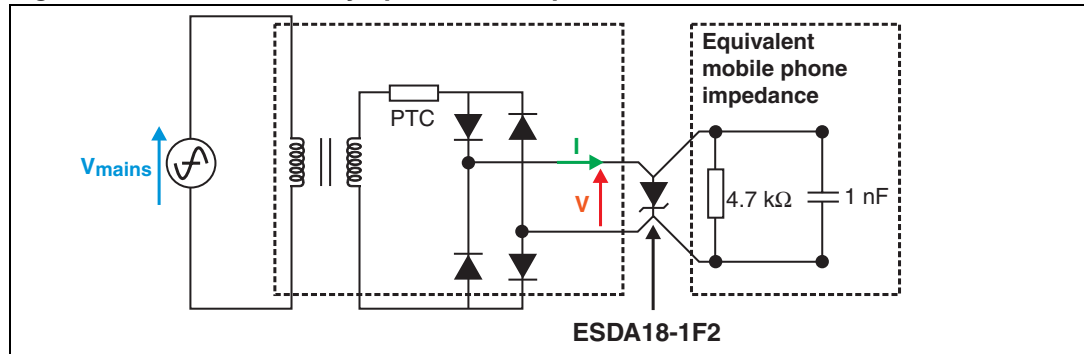

**Figure 9. Reverse battery operation results**

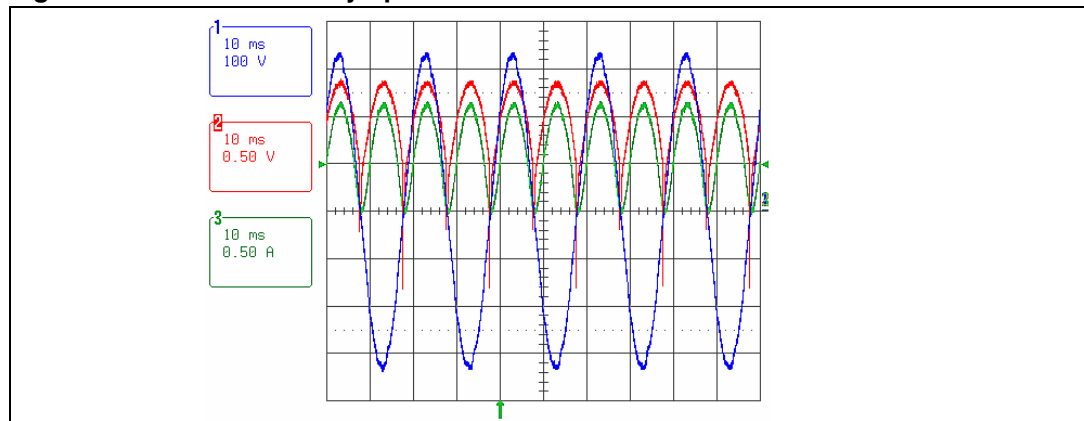

A short calculation based on Reverse battery operation results figures clearly show that in such real phone application the ESDA18-1F2 clamp the DC voltage below 1.3 V.

Typically the ESDA18-1F2 can clamp the DC voltage @ 0.9 V @ 0.76 A DC current:

$$V_{DC} = \frac{2 \times V_{max}}{\pi} \approx \frac{2 \times 1.4}{3.14} \approx 0.9V$$

$$I_{DC} = \frac{2 \times I_{max}}{\pi} \approx \frac{2 \times 1.2}{3.14} \approx 0.76A$$

### 3 Ordering information scheme

Figure 10. Ordering information scheme

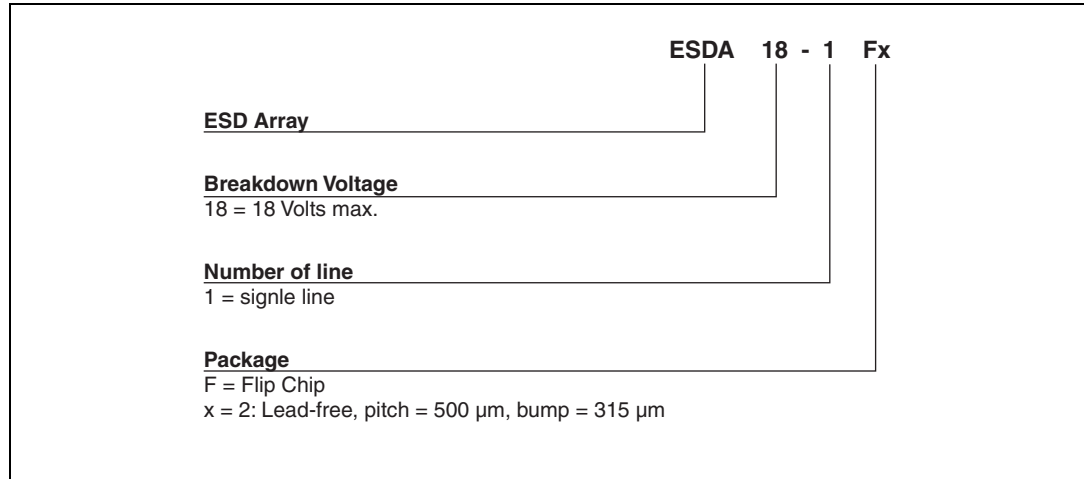

### 4 Packing information

In order to meet environmental requirements, ST offers these devices in ECOPACK® packages. These packages have a lead-free second level interconnect. The category of second level interconnect is marked on the inner box label, in compliance with JEDEC Standard JESD97. The maximum ratings related to soldering conditions are also marked on the inner box label. ECOPACK is an ST trademark. ECOPACK specifications are available at [www.st.com](http://www.st.com).

Figure 11. Flip Chip package dimensions

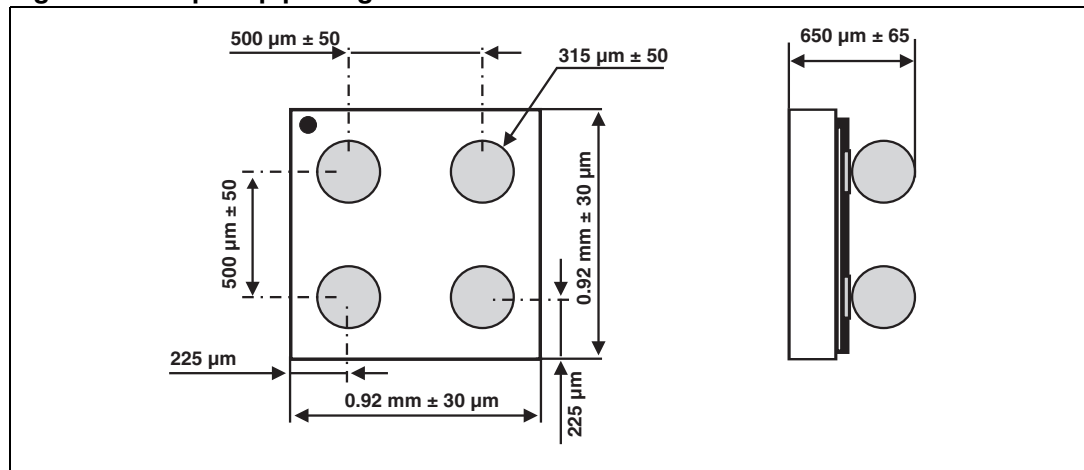

Figure 12. Footprint recommendations Figure 13. Marking

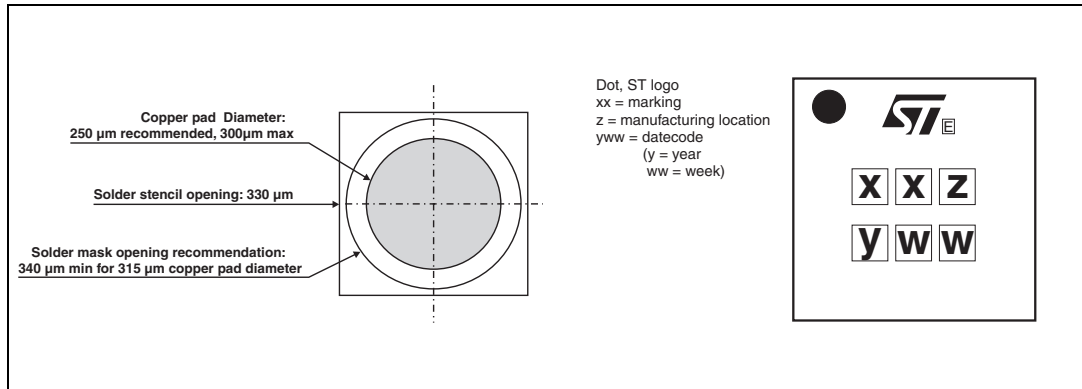
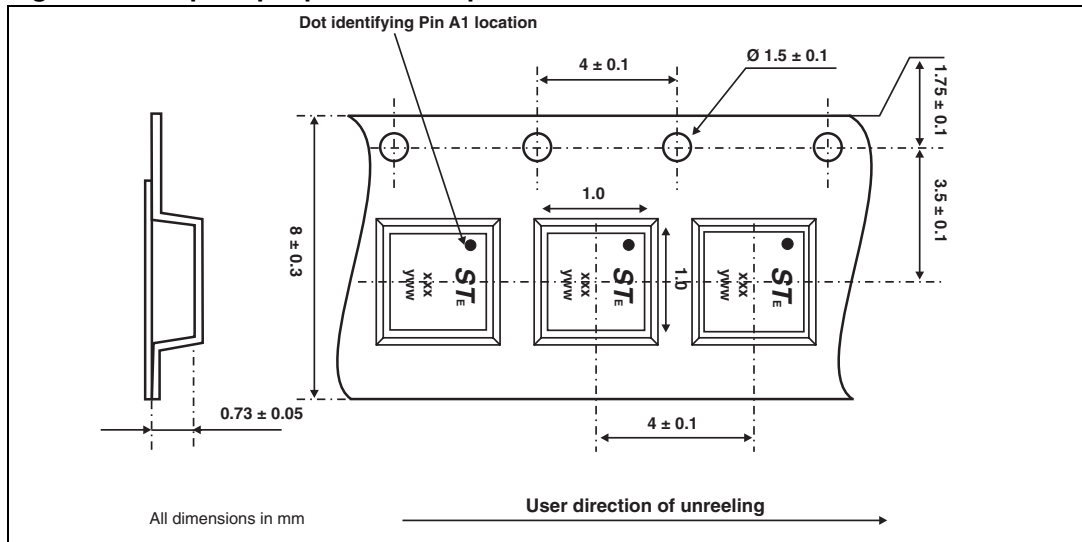

Figure 14. Flip Chip tape and reel specification



Note: More packing information is available in the application notes:  
 AN1235: "Flip Chip: Package description and recommendations for use"  
 AN1751: "EMI Filters: Recommendations and measurements"

## 5 Ordering information

Table 3. Ordering Information

Order code	Marking	Package	Weight	Base qty	Delivery mode
ESDA18-1F2	EE	Flip Chip	1.25 mg	5000	Tape and reel 7"

## 6 Revision history

Table 4. Document revision history

Date	Revision	Changes
09-May-2005	1	First issue.
18-Apr-2008	2	Updated ECOPACK statement. Updated <a href="#">Figure 11</a> , <a href="#">Figure 13</a> , and <a href="#">Figure 14</a> . Reformatted to current standards.

**Please Read Carefully:**

Information in this document is provided solely in connection with ST products. STMicroelectronics NV and its subsidiaries ("ST") reserve the right to make changes, corrections, modifications or improvements, to this document, and the products and services described herein at any time, without notice.

All ST products are sold pursuant to ST's terms and conditions of sale.

Purchasers are solely responsible for the choice, selection and use of the ST products and services described herein, and ST assumes no liability whatsoever relating to the choice, selection or use of the ST products and services described herein.

No license, express or implied, by estoppel or otherwise, to any intellectual property rights is granted under this document. If any part of this document refers to any third party products or services it shall not be deemed a license grant by ST for the use of such third party products or services, or any intellectual property contained therein or considered as a warranty covering the use in any manner whatsoever of such third party products or services or any intellectual property contained therein.

**UNLESS OTHERWISE SET FORTH IN ST'S TERMS AND CONDITIONS OF SALE ST DISCLAIMS ANY EXPRESS OR IMPLIED WARRANTY WITH RESPECT TO THE USE AND/OR SALE OF ST PRODUCTS INCLUDING WITHOUT LIMITATION IMPLIED WARRANTIES OF MERCHANTABILITY, FITNESS FOR A PARTICULAR PURPOSE (AND THEIR EQUIVALENTS UNDER THE LAWS OF ANY JURISDICTION), OR INFRINGEMENT OF ANY PATENT, COPYRIGHT OR OTHER INTELLECTUAL PROPERTY RIGHT.**

**UNLESS EXPRESSLY APPROVED IN WRITING BY AN AUTHORIZED ST REPRESENTATIVE, ST PRODUCTS ARE NOT RECOMMENDED, AUTHORIZED OR WARRANTED FOR USE IN MILITARY, AIR CRAFT, SPACE, LIFE SAVING, OR LIFE SUSTAINING APPLICATIONS, NOR IN PRODUCTS OR SYSTEMS WHERE FAILURE OR MALFUNCTION MAY RESULT IN PERSONAL INJURY, DEATH, OR SEVERE PROPERTY OR ENVIRONMENTAL DAMAGE. ST PRODUCTS WHICH ARE NOT SPECIFIED AS "AUTOMOTIVE GRADE" MAY ONLY BE USED IN AUTOMOTIVE APPLICATIONS AT USER'S OWN RISK.**

Resale of ST products with provisions different from the statements and/or technical features set forth in this document shall immediately void any warranty granted by ST for the ST product or service described herein and shall not create or extend in any manner whatsoever, any liability of ST.

ST and the ST logo are trademarks or registered trademarks of ST in various countries.

Information in this document supersedes and replaces all information previously supplied.

The ST logo is a registered trademark of STMicroelectronics. All other names are the property of their respective owners.

© 2008 STMicroelectronics - All rights reserved

STMicroelectronics group of companies

Australia - Belgium - Brazil - Canada - China - Czech Republic - Finland - France - Germany - Hong Kong - India - Israel - Italy - Japan - Malaysia - Malta - Morocco - Singapore - Spain - Sweden - Switzerland - United Kingdom - United States of America

[www.st.com](http://www.st.com)