

Trisil™ for telecom equipment protection

Features

- Bidirectional crowbar protection
- Voltage: range from 140 V to 400 V
- Low V_{BO} / V_R ratio
- Micro capacitance from 15 pF to 30 pF @ 50 V
- Low leakage current: $I_R = 2 \mu\text{A}$ max
- Holding current: $I_H = 150 \text{ mA}$ min.
- Repetitive peak pulse current:
 $I_{PP} = 100 \text{ A}$ (10/1000 μs)

Benefits

- Trisils are not subject to ageing and provide a fail safe mode in short circuit for better protection.
- Helps equipment meet main standards such as UL60950, IEC 950 / CSA C22.2 and UL1459.
- Epoxy meets UL94, V0.
- Package is JEDEC registered (DO-214AA).

Complies with the following standards

- GR-1089 Core
- ITU-T-K20/K21
- IEC 61000-4-5
- TIA/EIA IS-968
- UL497B recognized, UL file E136224

Applications

Any sensitive equipment requiring protection against lightning strikes and power crossing:

- Terminals (phone, fax, modem...) and central office equipment
- ADSL2+ and low end VDSL

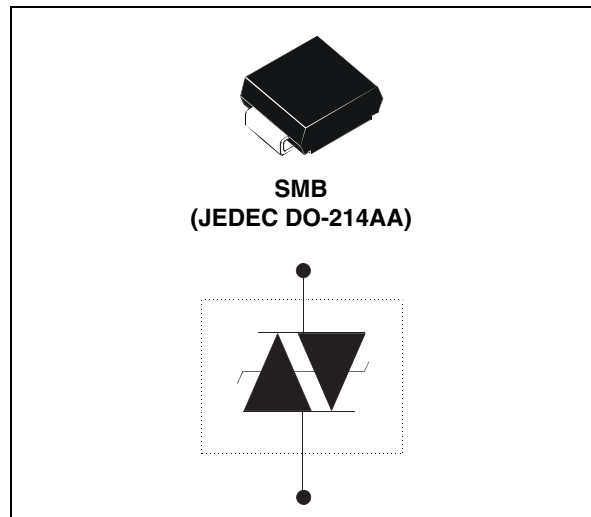

Description

The SMP100MC is a series of micro capacitance transient surge arrestors designed for the protection of high debit rate communication equipment. Its micro capacitance avoids any distortion of the signal and is compatible with digital transmission line cards (ADSL, VDSL, ISDN...).

SMP100MC series has been tested and confirmed compatible with Cooper Bussmann Telecom Circuit Protector TCP 1.25 A.

TM: Trisil is a trademark of STMicroelectronics.

1 Characteristics

Table 1. In compliance with the following standards

Standard	Peak surge voltage (V)	Waveform voltage	Required peak current (A)	Current waveform	Minimum serial resistor to meet standard (Ω)
GR-1089 Core First level	2500	2/10 μ s	500	2/10 μ s	0
	1000	10/1000 μ s	100	10/1000 μ s	0
GR-1089 Core Second level	5000	2/10 μ s	500	2/10 μ s	0
GR-1089 Core Intra-building	1500	2/10 μ s	100	2/10 μ s	0
ITU-T-K20/K21	6000	10/700 μ s	150	5/310 μ s	0
	1500		37.5		0
ITU-T-K20 (IEC61000-4-2)	8000	1/60 ns	ESD contact discharge		0
	15000		ESD air discharge		0
IEC61000-4-5	4000	10/700 μ s	100	5/310 μ s	0
	4000	1.2/50 μ s	100	8/20 μ s	0
TIA/EIA IS-968, lightning surge type A	1500	10/160 μ s	200	10/160 μ s	0
	800	10/560 μ s	100	10/560 μ s	0
TIA/EIA IS-968, lightning surge type B	1000	9/720 μ s	25	5/320 μ s	0

Table 2. Absolute ratings ($T_{amb} = 25\text{ }^{\circ}\text{C}$)

Symbol	Parameter	Value	Units	
I_{PP}	Repetitive peak pulse current	10/1000 μs	100	A
		8/20 μs	300	
		10/560 μs	140	
		5/310 μs	150	
		10/160 μs	200	
		1/20 μs	300	
		2/10 μs	500	
I_{FS}	Fail-safe mode: maximum current ⁽¹⁾	8/20 μs	5	kA
I_{TSM}	Non repetitive surge peak on-state current (sinusoidal)	t = 0.2 s	18	A
		t = 1 s	9	
		t = 2 s	7	
		t = 15 mn	4	
I^2t	I^2t value for fusing	t = 16.6 ms	20	A^2s
		t = 20 ms	21	
T_{stg}	Storage temperature range	-55 to 150	$^{\circ}\text{C}$	
T_j	Operating junction temperature range	-40 to 150	$^{\circ}\text{C}$	
T_L	Maximum lead temperature for soldering during 10 s.	260	$^{\circ}\text{C}$	

1. In fail safe mode the device acts as a short circuit.

Table 3. Thermal resistances

Symbol	Parameter	Value	Unit
$R_{th(j-a)}$	Junction to ambient (with recommended footprint)	100	$^{\circ}\text{C}/\text{W}$
$R_{th(j-l)}$	Junction to leads	20	$^{\circ}\text{C}/\text{W}$

Figure 1. Electrical characteristics - definitions ($T_{amb} = 25\text{ }^{\circ}\text{C}$)

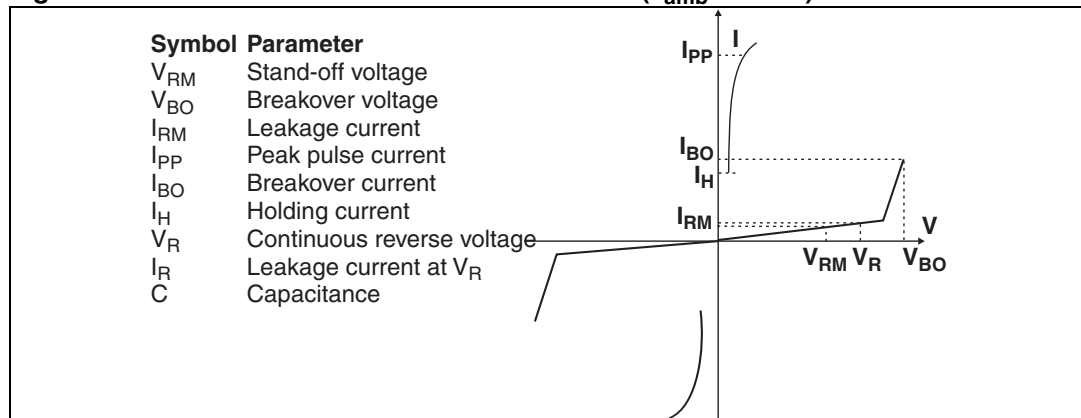

Table 4. Electrical characteristics - values ($T_{amb} = 25\text{ }^{\circ}\text{C}$)

Types	$I_{RM} @ V_{RM}$		$I_R @ V_R$		Dynamic $V_{BO}^{(1)}$	Static $V_{BO} @ I_{BO}^{(2)}$		$I_H^{(3)}$	$C^{(4)}$	$C^{(5)}$
	max.		max.		max.	max.	max.	min.	typ.	typ.
	μA	V	μA	V	V	V	mA	mA	pF	pF
SMP100MC-140	2	126	5	140	180	175	800	150	30	60
SMP100MC-160		144		160	205	200			25	50
SMP100MC-200		180		200	255	250			20	45
SMP100MC-230		207		230	295	285			20	40
SMP100MC-270		243		270	345	335			20	40
SMP100MC-320		290		320	400	390			15	35
SMP100MC-360		325		360	460	450			15	35
SMP100MC-400		360		400	540	530			15	30

1. See [Figure 16: Test circuit 1 for Dynamic IBO and VBO parameters](#)
2. See [Figure 17: Test circuit 2 for IBO and VBO parameters](#)
3. See [Figure 18: Test circuit 3 for dynamic IH parameter](#)
4. $V_R = 50\text{ V}$ bias, $V_{RMS}=1\text{V}$, $F=1\text{ MHz}$
5. $V_R = 2\text{ V}$ bias, $V_{RMS}=1\text{V}$, $F=1\text{ MHz}$

Figure 2. Pulse waveform

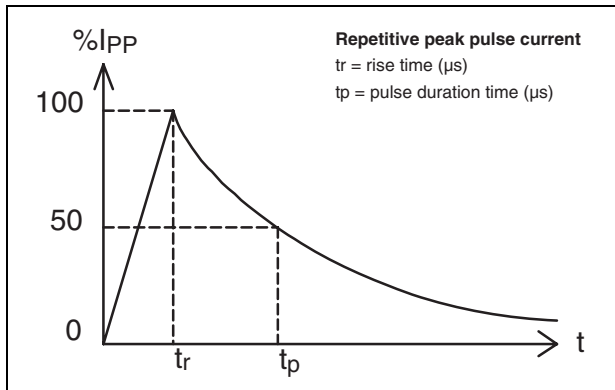

Figure 3. Non repetitive surge peak on-state current versus overload duration

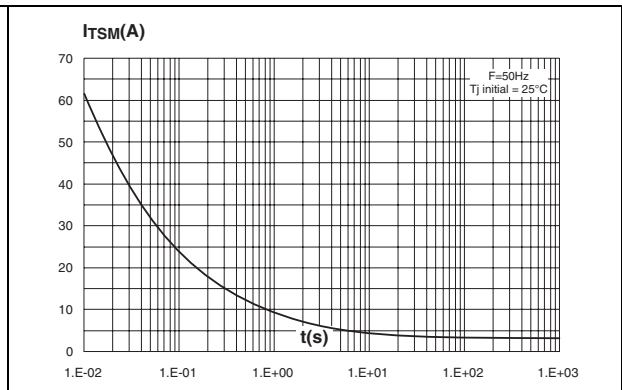

Figure 4. On-state voltage versus on-state current (typical values)

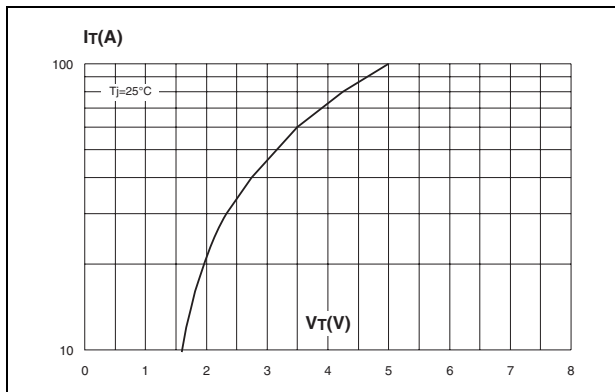

Figure 5. Relative variation of holding current versus junction temperature

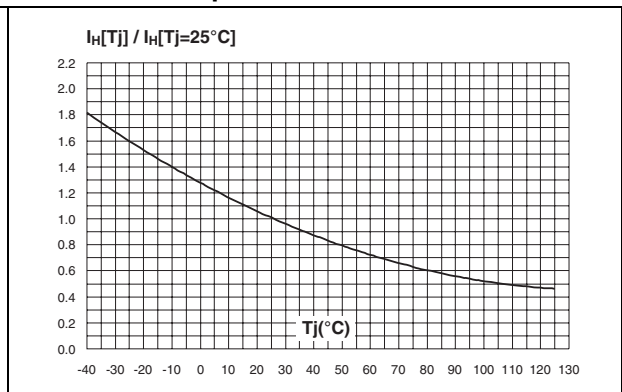

Figure 6. Relative variation of breakover voltage versus junction temperature

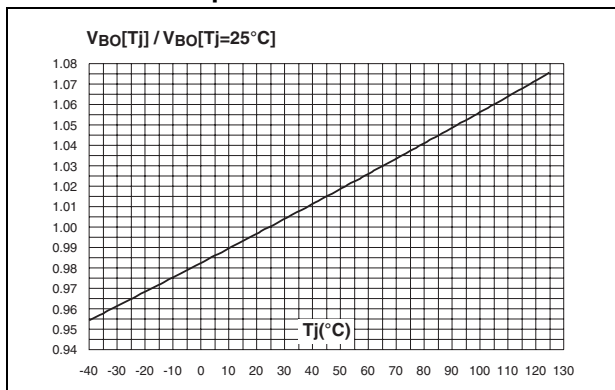

Figure 7. Relative variation of leakage current versus reverse voltage applied (typical values)

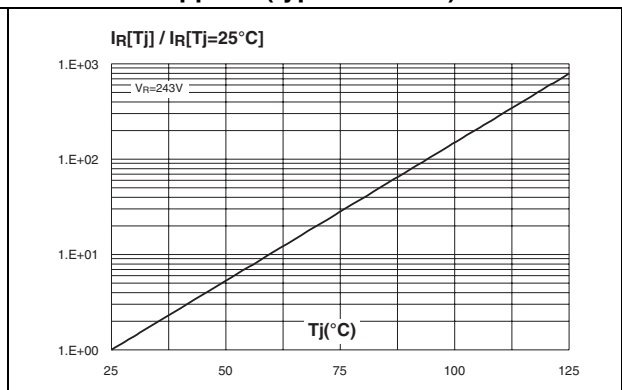

Figure 8. Variation of thermal impedance junction to ambient versus pulse duration

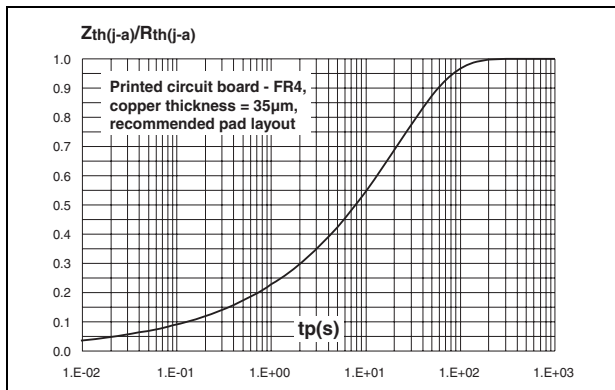
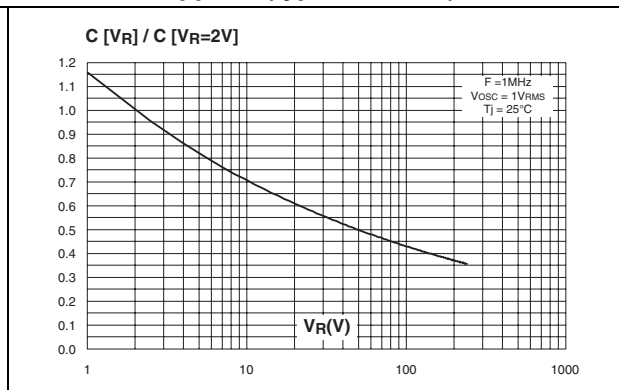

Figure 9. Relative variation of junction capacitance versus reverse voltage applied (typical values)



2 Application information

In wire line applications, analog or digital, both central office and subscriber sides have to be protected. This function is assumed by a combined series / parallel protection stage

Figure 10. Examples of protection stages for line cards

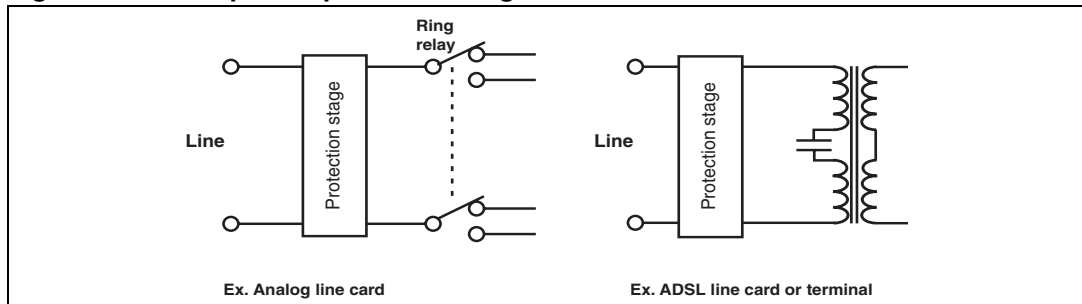

In such a stage, parallel function is assumed by one or several Trisil, and is used to protect against short duration surge (lightning). During this kind of surges the Trisil limits the voltage across the device to be protected at its break over value and then fires. The fuse assumes the series function, and is used to protect the module against long duration or very high current mains disturbances (50/60Hz). It acts by safe circuits opening. Lightning surge and mains disturbance surges are defined by standards like GR1089, TIA/EIA IS-968, ITU-T K20.

Figure 11. Typical circuits

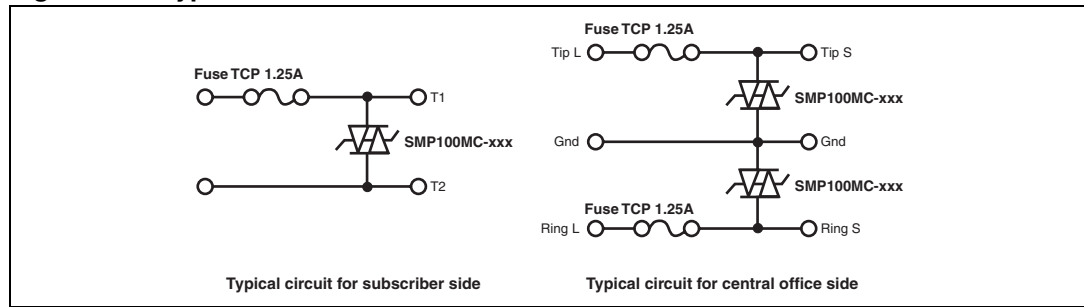
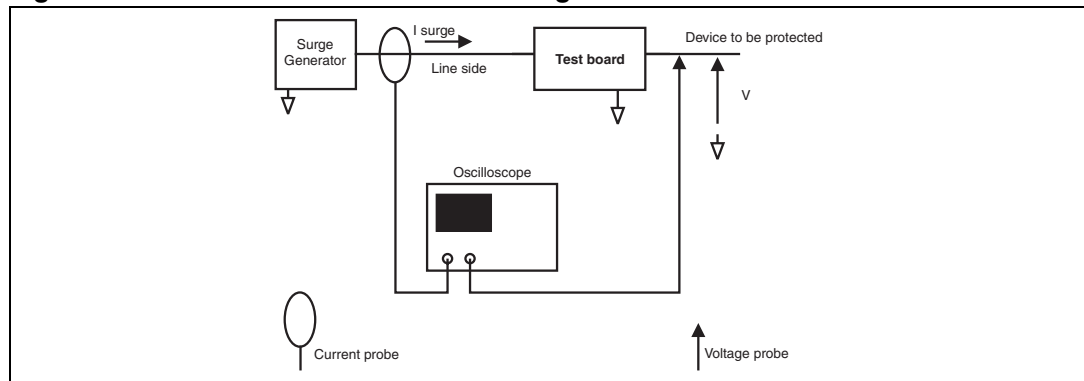
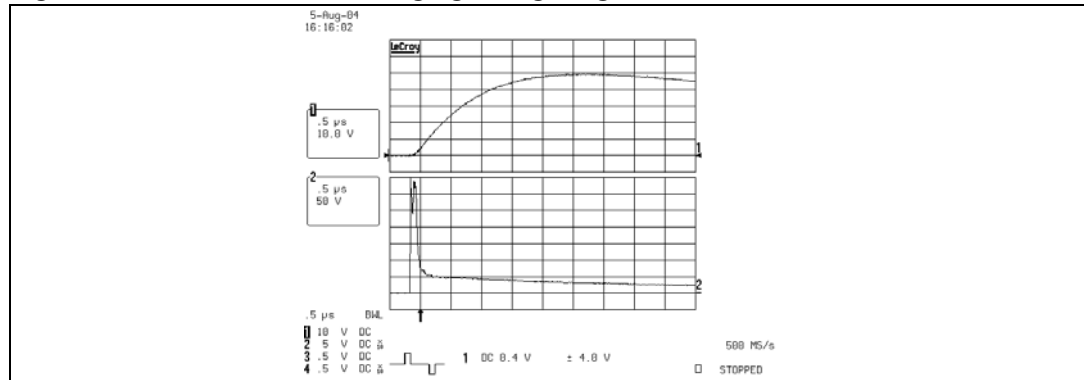

Figure 12. Test method of the board having fuse and Trisil



These topologies, using SMP100MC from ST and TCP1.25 A from Cooper Bussmann, have been functionally validated with a Trisil glued on the PCB. Following example was performed with SMP100MC-270 Trisil. For more information, see Application Note AN2064.

Figure 13. Trisil turns on during lightning surge



Test conditions:

2/10 μs + and -2.5 and 5 kV 500 A (10 pulses of each polarity), T_{amb} = 25 °C

Test result:

Fuse and Trisil OK after test in accordance with GR1089 requirements.

Figure 14. Trisil action while the fuse remains operational

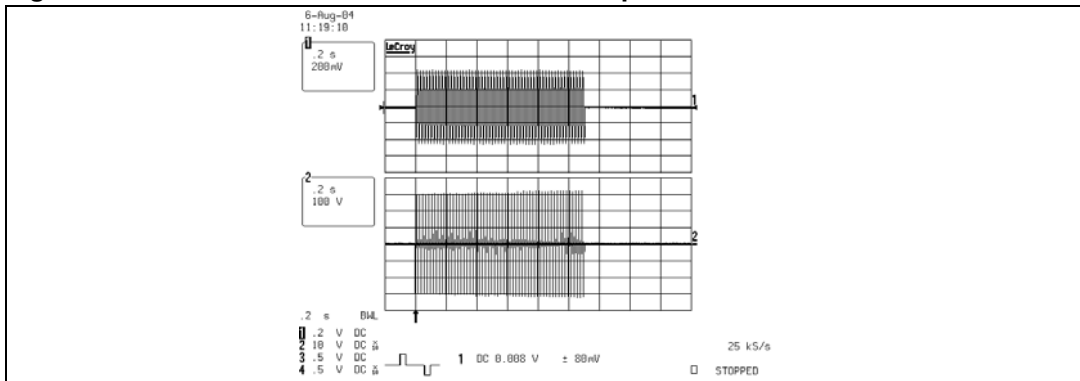

Test conditions:

600 V 3 A 1.1 s (first level), $T_{amb} = 25\text{ °C}$

Test result:

Fuse and Trisil OK after test in accordance with GR1089 requirements

Figure 15. High current power cross test: the fuse acts like a switch by opening the circuit

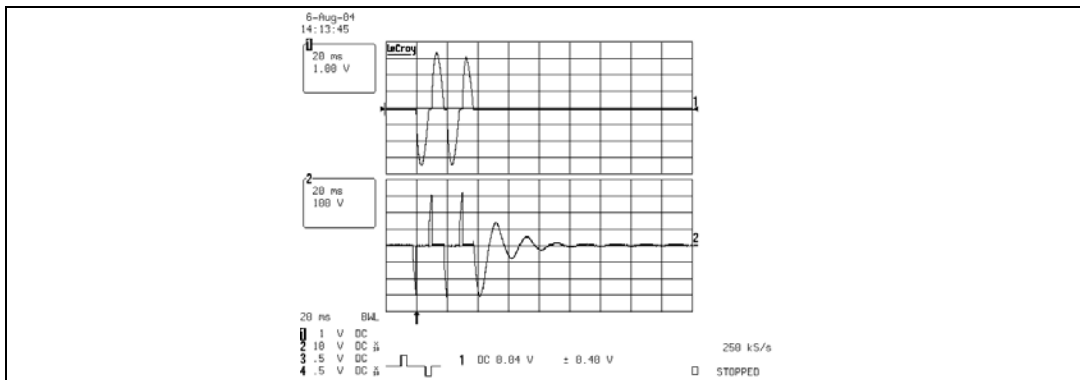

Test conditions:

277 V 25 A (second level), $T_{amb} = 25\text{ °C}$

Test result:

Fuse safety opened and Trisil OK after test in accordance with GR1089 requirements.

Figure 16. Test circuit 1 for Dynamic I_{BO} and V_{BO} parameters

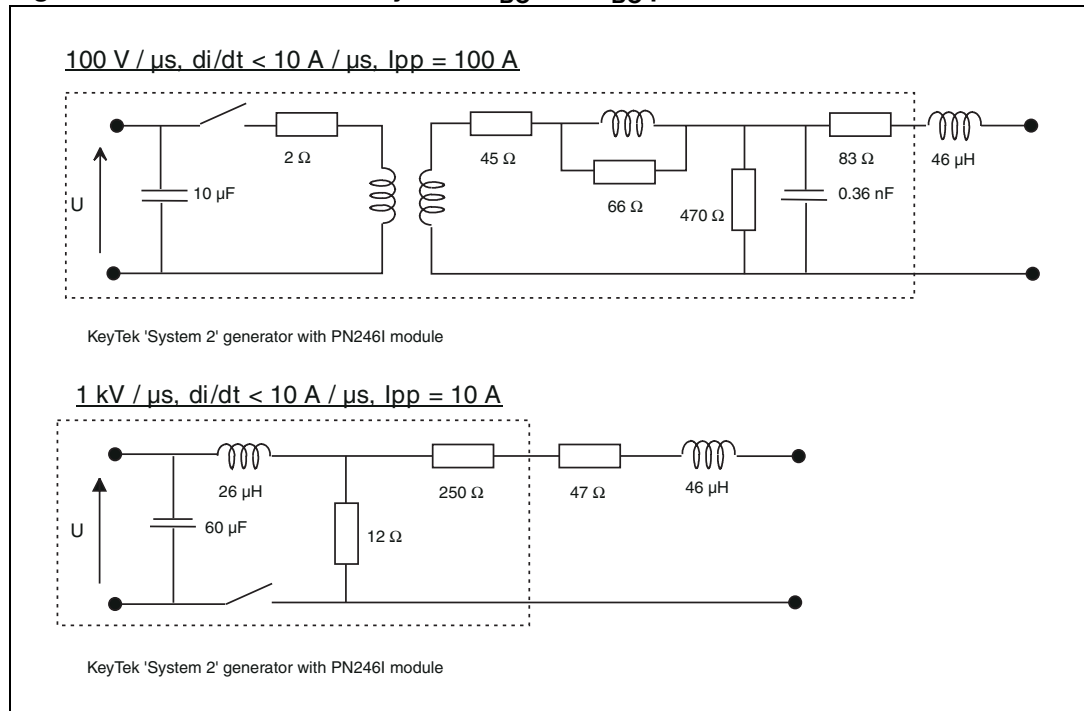

Figure 17. Test circuit 2 for I_{BO} and V_{BO} parameters

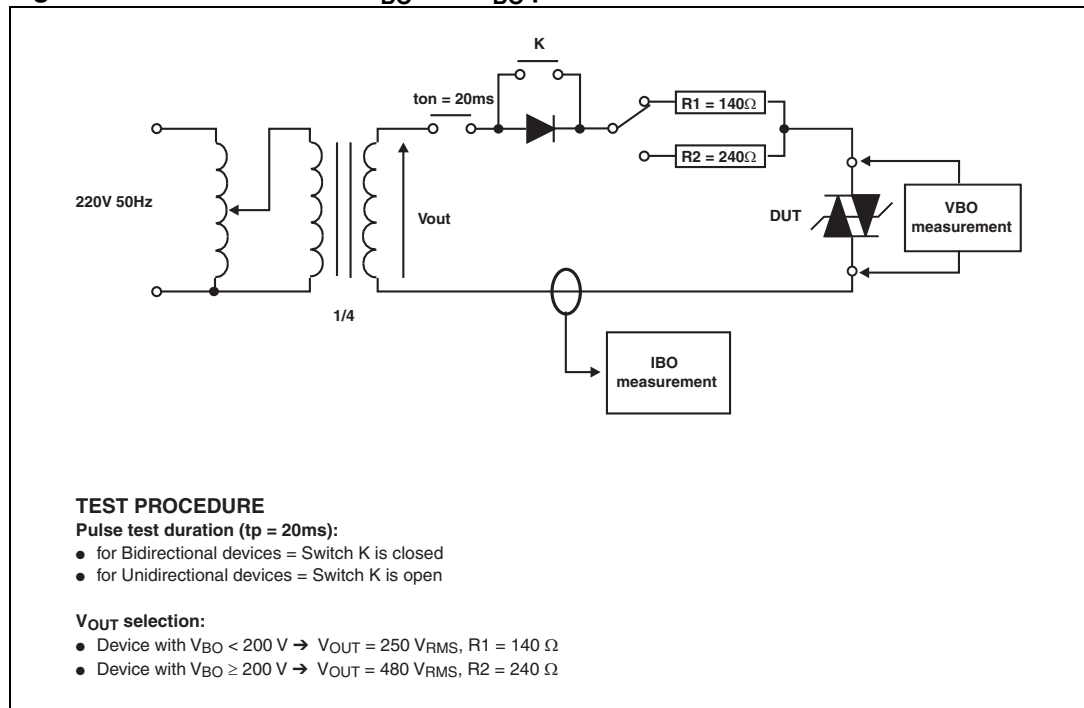
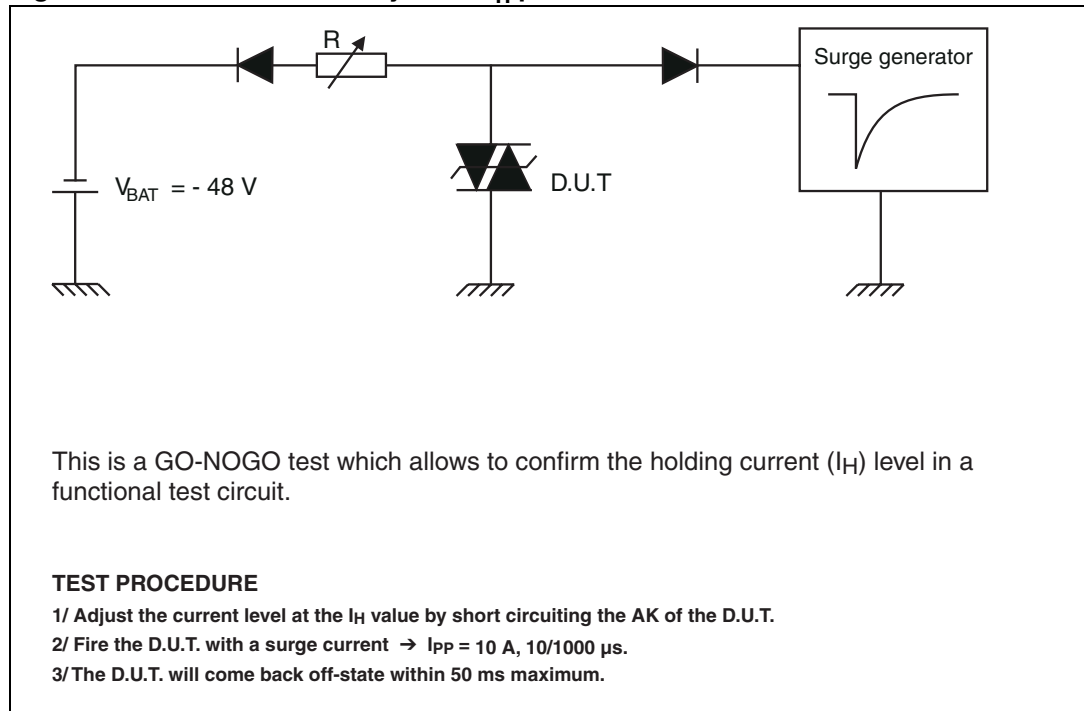
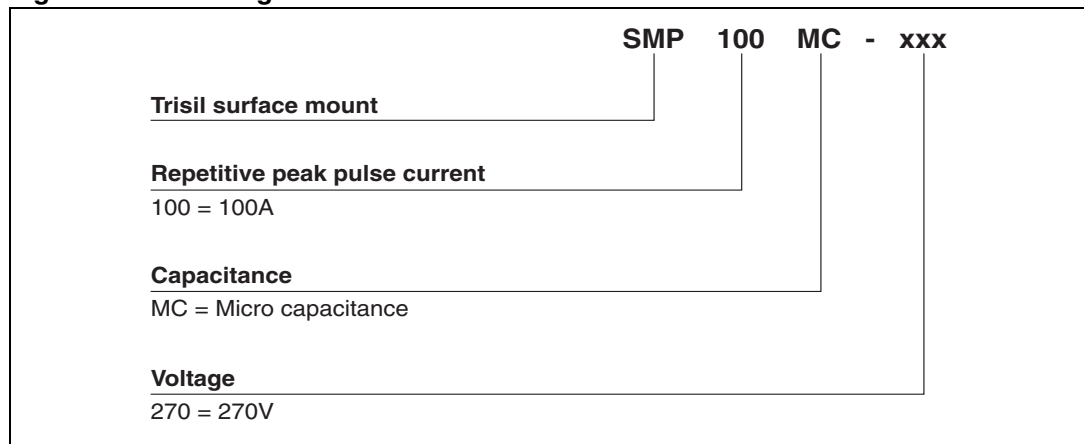

Figure 18. Test circuit 3 for dynamic I_H parameter



3 Ordering information scheme

Figure 19. Ordering information scheme



4 Package information

- Epoxy meets UL94, V0
- Lead-free package

In order to meet environmental requirements, ST offers these devices in different grades of ECOPACK® packages, depending on their level of environmental compliance. ECOPACK® specifications, grade definitions and product status are available at: www.st.com. ECOPACK® is an ST trademark.

Table 5. SMB dimensions

Ref.	Dimensions			
	Millimeters		Inches	
	Min.	Max.	Min.	Max.
A1	1.90	2.45	0.075	0.096
A2	0.05	0.20	0.002	0.008
b	1.95	2.20	0.077	0.087
c	0.15	0.40	0.006	0.016
E	5.10	5.60	0.201	0.220
E1	4.05	4.60	0.159	0.181
D	3.30	3.95	0.130	0.156
L	0.75	1.50	0.030	0.059

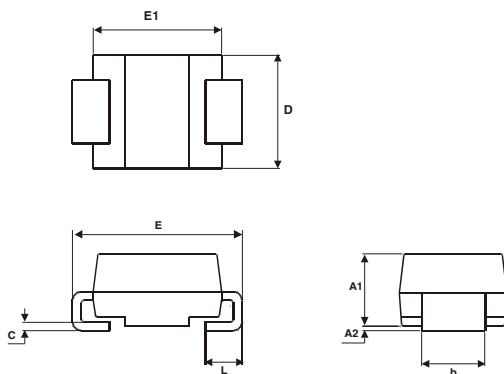
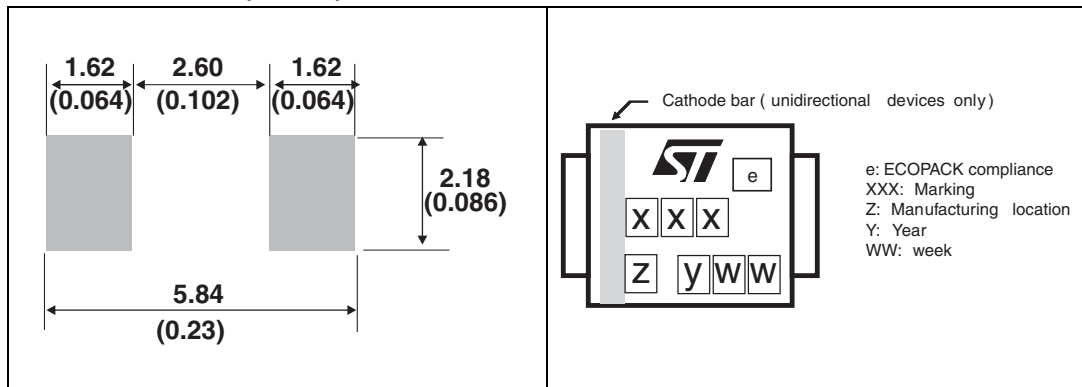

Figure 20. Footprint dimensions in mm (inches)

Figure 21. Marking layout⁽¹⁾



1. Marking layout can vary according to assembly location.

5 Ordering information

Table 6. Ordering information

Part Number	Marking	Package	Weight	Base qty	Delivery mode
SMP100MC-140	ML14	SMB	98 mg	2500	Tape and reel
SMP100MC-160	ML16				
SMP100MC-200	ML20				
SMP100MC-230	ML23				
SMP100MC-270	ML27				
SMP100MC-320	ML32				
SMP100MC-360	ML36				
SMP100MC-400	ML40				

6 Revision history

Table 7. Document revision history

Date	Revision	Changes
September-2003	0B	First issue.
14-Dec-2004	1	Absolute ratings values, table 3 on page 2, updated.
11-May-2005	2	New types introduction.
20-Jun-2005	3	Telecom Circuit Protector added
05-Jan-2006	4	SMP100MC-320 / 360 / 400 in full production ("in development" mention removed)
09-Feb-2012	5	Added UL statement in <i>Complies with the following standards.</i>

Please Read Carefully:

Information in this document is provided solely in connection with ST products. STMicroelectronics NV and its subsidiaries ("ST") reserve the right to make changes, corrections, modifications or improvements, to this document, and the products and services described herein at any time, without notice.

All ST products are sold pursuant to ST's terms and conditions of sale.

Purchasers are solely responsible for the choice, selection and use of the ST products and services described herein, and ST assumes no liability whatsoever relating to the choice, selection or use of the ST products and services described herein.

No license, express or implied, by estoppel or otherwise, to any intellectual property rights is granted under this document. If any part of this document refers to any third party products or services it shall not be deemed a license grant by ST for the use of such third party products or services, or any intellectual property contained therein or considered as a warranty covering the use in any manner whatsoever of such third party products or services or any intellectual property contained therein.

UNLESS OTHERWISE SET FORTH IN ST'S TERMS AND CONDITIONS OF SALE ST DISCLAIMS ANY EXPRESS OR IMPLIED WARRANTY WITH RESPECT TO THE USE AND/OR SALE OF ST PRODUCTS INCLUDING WITHOUT LIMITATION IMPLIED WARRANTIES OF MERCHANTABILITY, FITNESS FOR A PARTICULAR PURPOSE (AND THEIR EQUIVALENTS UNDER THE LAWS OF ANY JURISDICTION), OR INFRINGEMENT OF ANY PATENT, COPYRIGHT OR OTHER INTELLECTUAL PROPERTY RIGHT.

UNLESS EXPRESSLY APPROVED IN WRITING BY TWO AUTHORIZED ST REPRESENTATIVES, ST PRODUCTS ARE NOT RECOMMENDED, AUTHORIZED OR WARRANTED FOR USE IN MILITARY, AIR CRAFT, SPACE, LIFE SAVING, OR LIFE SUSTAINING APPLICATIONS, NOR IN PRODUCTS OR SYSTEMS WHERE FAILURE OR MALFUNCTION MAY RESULT IN PERSONAL INJURY, DEATH, OR SEVERE PROPERTY OR ENVIRONMENTAL DAMAGE. ST PRODUCTS WHICH ARE NOT SPECIFIED AS "AUTOMOTIVE GRADE" MAY ONLY BE USED IN AUTOMOTIVE APPLICATIONS AT USER'S OWN RISK.

Resale of ST products with provisions different from the statements and/or technical features set forth in this document shall immediately void any warranty granted by ST for the ST product or service described herein and shall not create or extend in any manner whatsoever, any liability of ST.

ST and the ST logo are trademarks or registered trademarks of ST in various countries.

Information in this document supersedes and replaces all information previously supplied.

The ST logo is a registered trademark of STMicroelectronics. All other names are the property of their respective owners.

© 2012 STMicroelectronics - All rights reserved

STMicroelectronics group of companies

Australia - Belgium - Brazil - Canada - China - Czech Republic - Finland - France - Germany - Hong Kong - India - Israel - Italy - Japan - Malaysia - Malta - Morocco - Philippines - Singapore - Spain - Sweden - Switzerland - United Kingdom - United States of America

www.st.com