

Monolithic 2-channel power management for high-definition ODD with integrated power switch

Features

- 1.2 MHz DC-DC current mode PWM converter
- Input voltage from 4 V up to 6 V
- Step-down 3.3 V fixed output voltage, up to 700 mA load
- Step-up output current up to 500 mA
- 2% step-down output voltage tolerance
- 3% step-up output voltage tolerance
- Synchronous rectification
- Step-down power-save mode at light load
- Typical efficiency: 90%
- Internal soft-start
- Enable functions
- True cutoff function for step-up converter
- Integrated motor control power switch
- Uses tiny capacitors and inductors
- Available in QFN16 (4 x 4 mm)

Description

The STODD03 is a 2-channel power management device intended for Blu-Ray applications based on high density optical storage devices. It integrates one step-down converter able to provide 3.3 V fixed output voltage up to 700 mA load, and one step-up converter to provide the power supply needed for the blue laser in applications where only 5 V input voltage is available. The step-up output voltage is adjustable in the range from 6.5 V to 14 V, with current capability up to 500 mA. Both step-down and step-up channels integrate low R_{DS_ON} N-channel and P-channel MOSFETs, allowing high DC-DC efficiencies. The enable function with true

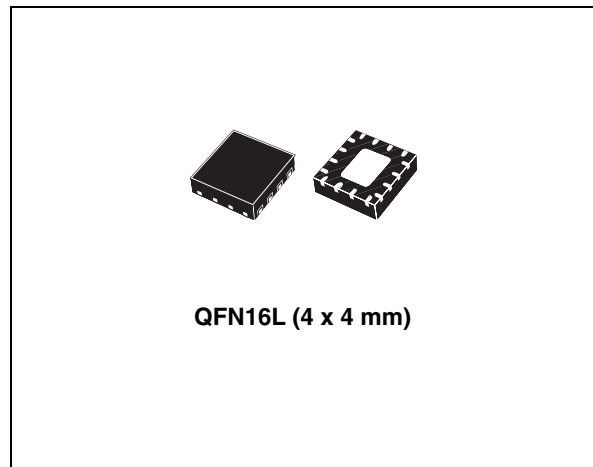

shutdown makes the step-up section particularly suitable for optical storage power management applications. Moreover, the STODD03 has a 1 A integrated power switch for motor control power supply. The high switching frequency allows the use of tiny SMD components. Low output ripple voltage is achieved thanks to the current mode PWM topology. The device includes soft-start control, thermal shutdown, and peak current limit to prevent damage due to accidental overload. The STODD03 is packaged in a QFN16 (4 x 4 mm).

Table 1. Device summary

Part number	Order code	Marking	Package
STODD03	STODD03PQR	ODD03	QFN16 (4 x 4 mm)

Contents

1	Block diagram	3
2	Absolute maximum ratings	4
3	Pin configuration	5
4	Typical application	7
5	Electrical characteristics	8
6	Package mechanical data	11
7	Revision history	15

1 Block diagram

Figure 1. Block diagram

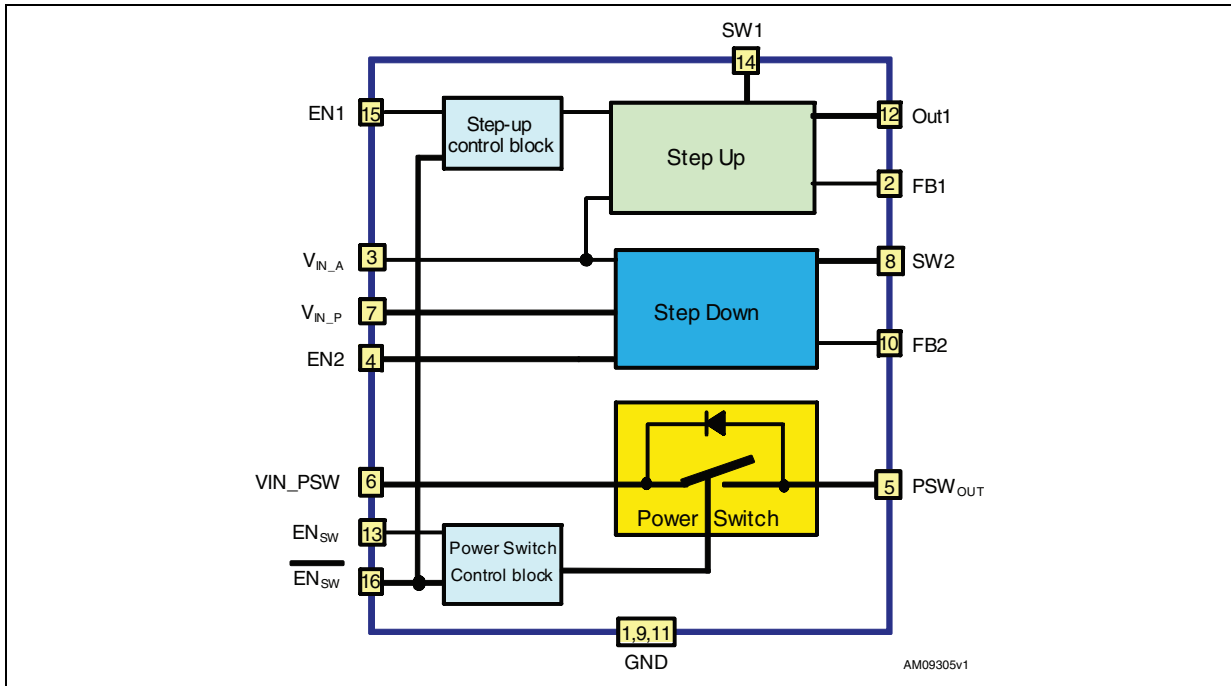

2 Absolute maximum ratings

Table 2. Absolute maximum ratings

Symbol	Parameter	Value	Unit
V _{IN_P}	Power supply input voltage	-0.3 to 7	V
VIN_PSW	Power switch input voltage	-0.3 to 7	V
V _{IN_A}	Analog supply input voltage	-0.3 to 7	V
EN _{XX}	All enable pins voltage	-0.3 to V _{IN_A}	V
SW1	Ch1 input switching pin	-0.3 to 16	V
SW2	Ch2 output switching pin	-0.3 to 7	V
PSW _{OUT}	Power switch output pin	-0.3 to 7	V
I _{SW}	Power switch max output current	1.2	A
OUT ₁	Ch1 output voltage pin	-0.3 to 16	V
FB ₁	Ch1 feedback voltage pin	-0.3 to 2.5	V
FB ₂	Ch2 feedback voltage pin	-0.3 to 5	V
T _{STG}	Storage temperature range	-50 to 150	°C
T _{OP}	Operating junction temperature range	-25 to 125	°C

Note: Absolute maximum ratings are those values beyond which damage to the device may occur. Functional operation under these conditions is not implied. All values are referred to gnd.

Table 3. Thermal data

Symbol	Parameter	Value	Unit
R _{thJC}	Thermal resistance junction-case	2.5	°C/W
R _{thJA}	Thermal resistance junction-ambient	46	°C/W

3 Pin configuration

Figure 2. Pin connections (top view)

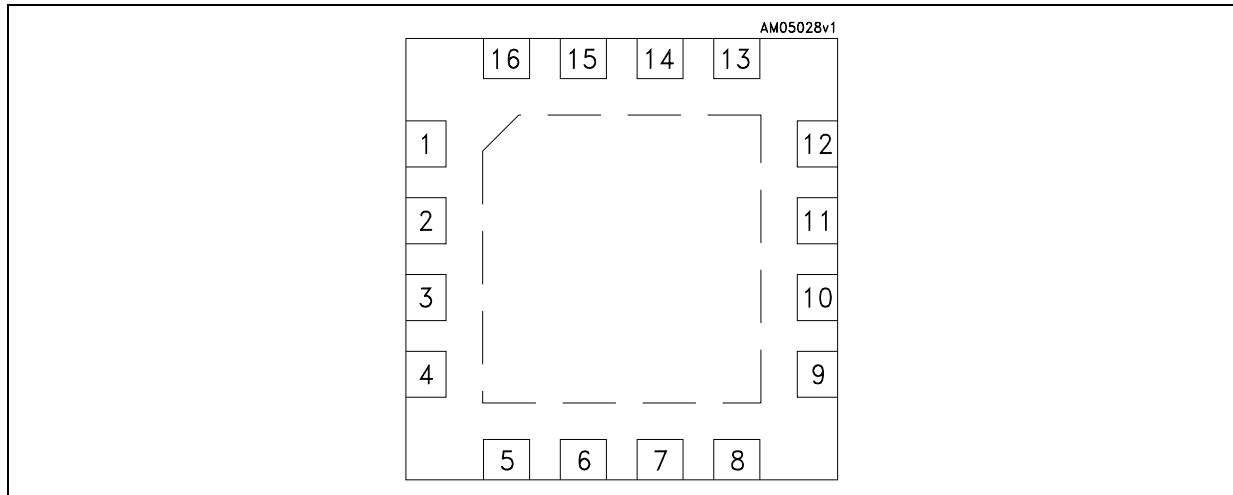

Table 4. Pin description

Pin number	Symbol	Function
1	GND_P1	Power ground pin (ch1)
2	FB1	Step-up feedback pin (ch1)
3	V _{IN_A}	Power supply for internal analog circuits
4	EN2	Step-down enable pin. Connect to V _{IN_A} if not used.
5	PSW _{OUT}	Power switch output pin. PSW _{OUT} output current is not internally limited. Do not exceed 1 A max.
6	VIN_PSW	Power switch input
7	V _{IN_P}	Power input voltage
8	SW2	Step-down switching pin (ch2)
9	GND_P2	Power ground (ch2)
10	FB2	Step-down feedback (ch2)
11	GND_A	Analog ground pin
12	OUT1	Step-up output voltage
13	EN-SW	Power switch enable pin active high (see Table 5)
14	SW1	Step-up switching pin (ch1)
15	EN1	Step-up enable pin. Step-up is enabled if EN1 > 1.2 V and $\overline{\text{EN-SW}}$ is set low (see also Table 6: Step-up EN1 and EN-SW truth table). When the step-up is disabled, no current will flow to the load thanks to the true-shutdown function.
16	$\overline{\text{EN-SW}}$	Power switch Enable pin active low (see Table 5)
epad	Epad	Exposed pad to be connected to a suitable gnd layer area, through vias, for thermal heat dissipation.

Table 5. Power switch truth table

EN-SW	$\overline{\text{EN-SW}}$	Power switch status
H	H	Open
L	L	Open
L	H	Open
H	L	Close

Table 6. Step-up EN1 and $\overline{\text{EN-SW}}$ truth table

EN-SW	EN1	$\overline{\text{EN-SW}}$	Step-up output status
x	H	H	OFF
x	L	H	OFF
x	L	L	OFF
x	H	L	ON

4 Typical application

Figure 3. Application circuit

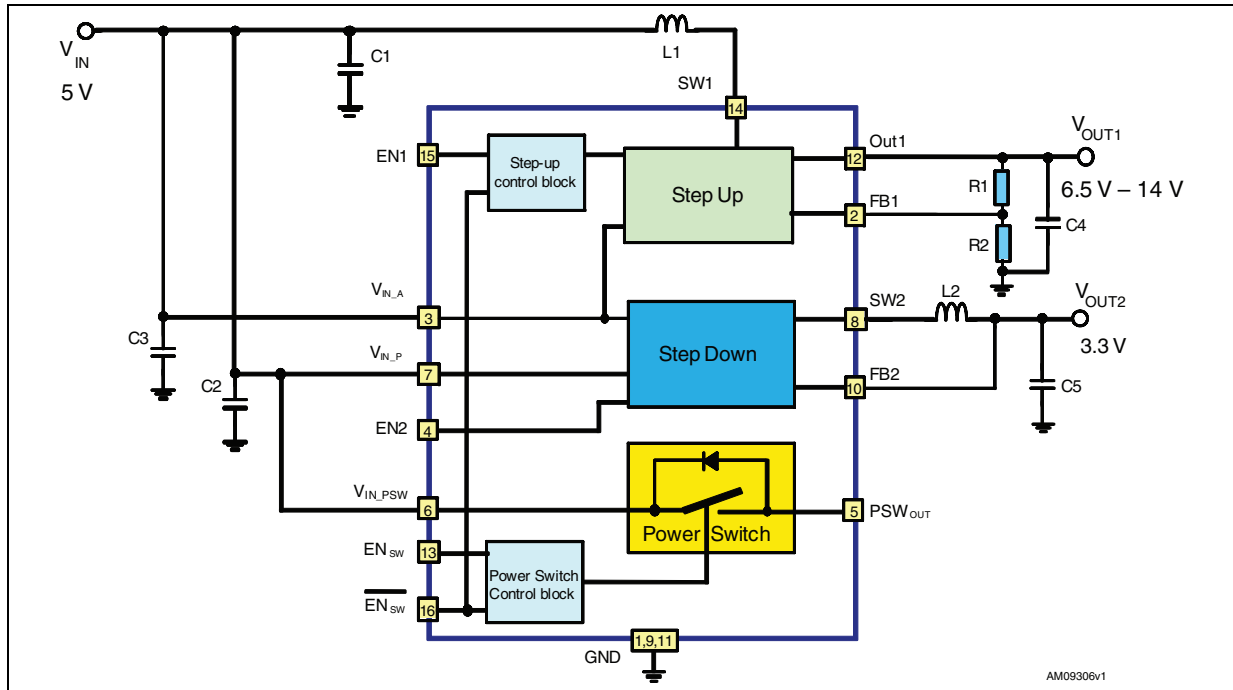

Table 7. List of external components (1)

Component	Value	Recommended part number
C1, C2, C3	10 μ F	Murata, GRM21BR61A106KE19L
C4, C5	22 μ F	Murata, GRM32ER61C226KE20L
L1	4.7 μ H	Coilcraft, LPS6225-472MLB
L2	3.3 μ H	Coilcraft, LPS4018-332MLB
R1, R2	33 k Ω , 3.3 k Ω	$V_{OUT1} = 8.8 \text{ V}$ (2)

- The components listed above refer to a typical applications circuit. Operation of the STODD03 is not limited to the choice of these external components. If a different solution is used, it is recommended to validate the suitability of the external components by thoroughly testing the application on a PCB evaluation board.
- R1 and R2 are calculated according to the following formula:
 $R1 = R2 \times [(V_{OUT1} / V_{FB1}) - 1]$. Resistors in the range of 1 k to 50 k are recommended.

5 Electrical characteristics

Refer to the typical application circuit, $V_{IN_P} = V_{IN_A} = V_{IN_PSW} = V_{EN1,2} = 5\text{ V}$, $V_{OUT1} = 9\text{ V}$, $V_{OUT2} = 3.3\text{ V}$, $C_{1,2,3} = 10\text{ }\mu\text{F}$, $C_{4,5} = 22\text{ }\mu\text{F}$, $L1 = 4.7\text{ }\mu\text{H}$, $L2 = 3.3\text{ }\mu\text{H}$, $T_J = -25\text{ to }125\text{ }^\circ\text{C}$ (unless otherwise specified, typical values are given at $T_J = 25\text{ }^\circ\text{C}$).

Table 8. Electrical characteristics

Symbol	Parameter	Test conditions	Min.	Typ.	Max.	Unit
V_{IN}	Input voltage range		4		6	V
I_{SUPPLY}	Supply current	$V_{EN1,2} > 1.2\text{ V}$, no switching		1.6	2	mA
		$V_{EN1,2} < 0.4\text{ V}$, no switching		1.2	2	mA
Step-up section						
V_{OUT}	Output voltage range		6.5		14	V
V_{FB1}	Feedback voltage	$T_J = 0\text{ to }85\text{ }^\circ\text{C}$	0.776	0.8	0.824	V
	Feedback voltage accuracy	$T_J = 0\text{ to }85\text{ }^\circ\text{C}$	-3		3	%
I_{FB1}	Feedback current	$V_{FB1} = 0\text{ V}$, $V_{EN1} = 2\text{ V}$		600		nA
I_{OUT1_OFF} (leak)	Output leakage current	$V_{EN} = 0\text{ V}$, $T_J = 0\text{ to }80\text{ }^\circ\text{C}$			20	μA
V_{OUT1_OVP}	Overvoltage protection ⁽¹⁾	$V_{FB1} = 0\text{ V}$	14.8	15.3	15.8	V
R_{DSon_N}	Internal N-channel R_{DSon}	$I_{SW1} = 400\text{ mA}$		300		m Ω
R_{DSon_P}	Internal P-channel R_{DSon}	$I_{SW1} = 400\text{ mA}$		300		
I_{SW1} (leak)	Internal leakage current	$V_{SW1} = 4\text{ V}$, $V_{FB1} = 2\text{ V}$, $V_{EN1} = 0\text{ V}$		2		μA
I_{SW1} (LIM)	SW current limitation	$V_{OUT1} = 9.2\text{ V}$		2.6		A
PWM f_s	Oscillator frequency	to be measured on SW1 pin	0.75	1.2	1.5	MHz
D_{MAX}	Max oscillator duty cycle	on SW1 pin, $V_{FB1} = 0.7\text{ V}$	70	90		%
η	Efficiency	$I_{OUT1} = 50\text{ mA}$, $V_{OUT1} = 7\text{ V}$		80		%
		$I_{OUT1} = 500\text{ mA}$, $V_{OUT1} = 7\text{ V}$		85		
		$I_{OUT1} = 100\text{ mA}$, $V_{OUT1} = 9\text{ V}$		75		
		$I_{OUT1} = 500\text{ mA}$, $V_{OUT1} = 9\text{ V}$		85		
V_{EN1_H}	Enable threshold high	$V_{IN} = 4\text{ to }6\text{ V}$	1.2			V
V_{EN1_L}	Enable threshold low	$V_{IN} = 4\text{ to }6\text{ V}$			0.4	
I_{EN1}	Enable pin current	$V_{EN1} = V_{IN} = 5\text{ V}$		2		μA
$\Delta V_{OUT1}/\Delta V_{IN}$	Line transient response ⁽²⁾	V_{IN} from 4 to 6 V, $I_{OUT1} = 500\text{ mA}$, $t_R = t_F \Rightarrow 30\text{ }\mu\text{s}$, $T_J = 25\text{ }^\circ\text{C}$	-5		5	% V_{OUT}
$\Delta V_{OUT1}/\Delta I_{OUT}$	Load transient response ⁽²⁾	$V_{IN} = 5\text{ V}$, I_{OUT1} from 100 mA to 500 mA, $t_R = t_F \Rightarrow 5\text{ }\mu\text{s}$, $T_J = 25\text{ }^\circ\text{C}$	-5		5	% V_{OUT}
$\Delta V_{OUT1}/\Delta V_{IN}$	Startup transient ⁽²⁾	V_{IN} from 0 to 5 V, $I_{OUT1} = 500\text{ mA}$	-10		10	% V_{OUT}
t_{START}	Startup time	V_{EN1} from 0 to 5 V, $I_{OUT1} = 100\text{ mA}$		500		μs
	Inrush current	$V_{OUT} = 9.25\text{ V}$, $I_{OUT} = 100\text{ mA}$		1.3		A

Table 8. Electrical characteristics (continued)

Symbol	Parameter	Test conditions	Min.	Typ.	Max.	Unit
Step-down section						
FB ₂	Feedback voltage	T _J = 0 to 85 °C	3.23	3.3	3.37	V
I _{FB2}	FB2 pin bias current	V _{FB2} = 3.5 V		15	20	μA
I _{OUT2}	Output current ⁽²⁾ ⁽³⁾	V _{IN} = 4 to 6 V	700			mA
I _{OUT_MIN}	Minimum output current		0			mA
ΔV _{OUT2}	Reference load regulation ⁽²⁾	10 mA < I _{OUT2} < 0.5 A		5.5	15	mV
PWM f _S	PWM switching frequency			1.2		MHz
%V _{OUT2} /ΔV _{IN}	Reference line regulation	4 V < V _{IN} < 6 V		0.032		%V _{OUT} / ΔV _{IN}
D _{MAX}	Maximum duty cycle	V _{FB2} = 3.0 V	85	94		%
I _{SWL}	Switching current limitation			1.5		A
I _{LKP2}	PMOS leakage current	V _{FB2} = 3.5 V, V _{SW2} = GND, T _J = 0 to 80 °C		0.1		μA
I _{LKN2}	NMOS leakage current	V _{FB2} = 3.5 V, V _{SW2} = 5 V, T _J = 0 to 80 °C		0.1		μA
R _{DSon} -N	NMOS switch-on resistance	I _{SW} = 250 mA		0.2		Ω
R _{DSon} -P	PMOS switch-on resistance	I _{SW} = 250 mA		0.3		Ω
ΔV _{OUT2} / ΔI _{OUT2}	Load transient response ⁽²⁾	100 mA < I _{OUT2} < 500 mA, t _R = t _F => 100 ns, T _J = 25 °C	-5		+5	%V _{OUT}
v	Efficiency	V _{OUT} = 3.3 V, I _{OUT} = 100 mA V _{OUT} = 3.3 V, I _{OUT} = 500 mA		75 85		%
V _{EN2_H}	Enable threshold high	V _{IN} = 4 to 6 V	1.2			V
V _{EN2_L}	Enable threshold low	V _{IN} = 4 to 6 V			0.4	V
I _{EN2}	Enable pin current	V _{EN2} = V _{IN} = 5 V		2		μA
Power switch section						
R _{DSon} -P	PMOS switch-on resistance	I _{SW} = 250 mA		0.3		Ω
I _{SW}	Switching operating current				1	A
I _{LKSW}	Switching leakage current	EN_SW = $\overline{\text{EN_SW}}$ = H, T _J = 0 to 80 °C		1		μA
V _{IN_PSW}	Input voltage range		4		6	V
V _{EN_SW_H}	Enable pins threshold high	V _{IN} = 4 to 6 V	1.2			V
V _{EN_SW_L}	Enable pins threshold low	V _{IN} = 4 to 6 V			0.4	V
I _{EN_SW}	Enable pins current	V _{EN_SW} = V _{IN} = 5 V		2		μA

Table 8. Electrical characteristics (continued)

Symbol	Parameter	Test conditions	Min.	Typ.	Max.	Unit
Thermal section						
T_{SHDN}	Thermal shutdown ⁽²⁾		130	150		°C
T_{HYS}	Thermal shutdown hyst. ⁽²⁾			15		°C

1. If $V_{\text{OUT1}} > \text{OVP}$, the device stops switching.
2. Guaranteed by design, but not tested in production.
3. $V_{\text{OUT}} = 90\%$ of nominal value

6 Package mechanical data

In order to meet environmental requirements, ST offers these devices in different grades of ECOPACK® packages, depending on their level of environmental compliance. ECOPACK specifications, grade definitions, and product status, are available at www.st.com. ECOPACK is an ST trademark.

Table 9. QFN16 (4 x 4 mm) mechanical data

Dim.	mm.		
	Min.	Typ.	Max.
A	0.80	0.90	1.00
A1	0.00	0.02	0.05
A3		0.20	
b	0.25	0.30	0.35
D	3.90	4.00	4.10
D2	2.50		2.80
E	3.90	4.00	4.10
E2	2.50		2.80
e		0.65	
L	0.30	0.40	0.50

Figure 4. QFN16 (4 x 4 mm) drawing

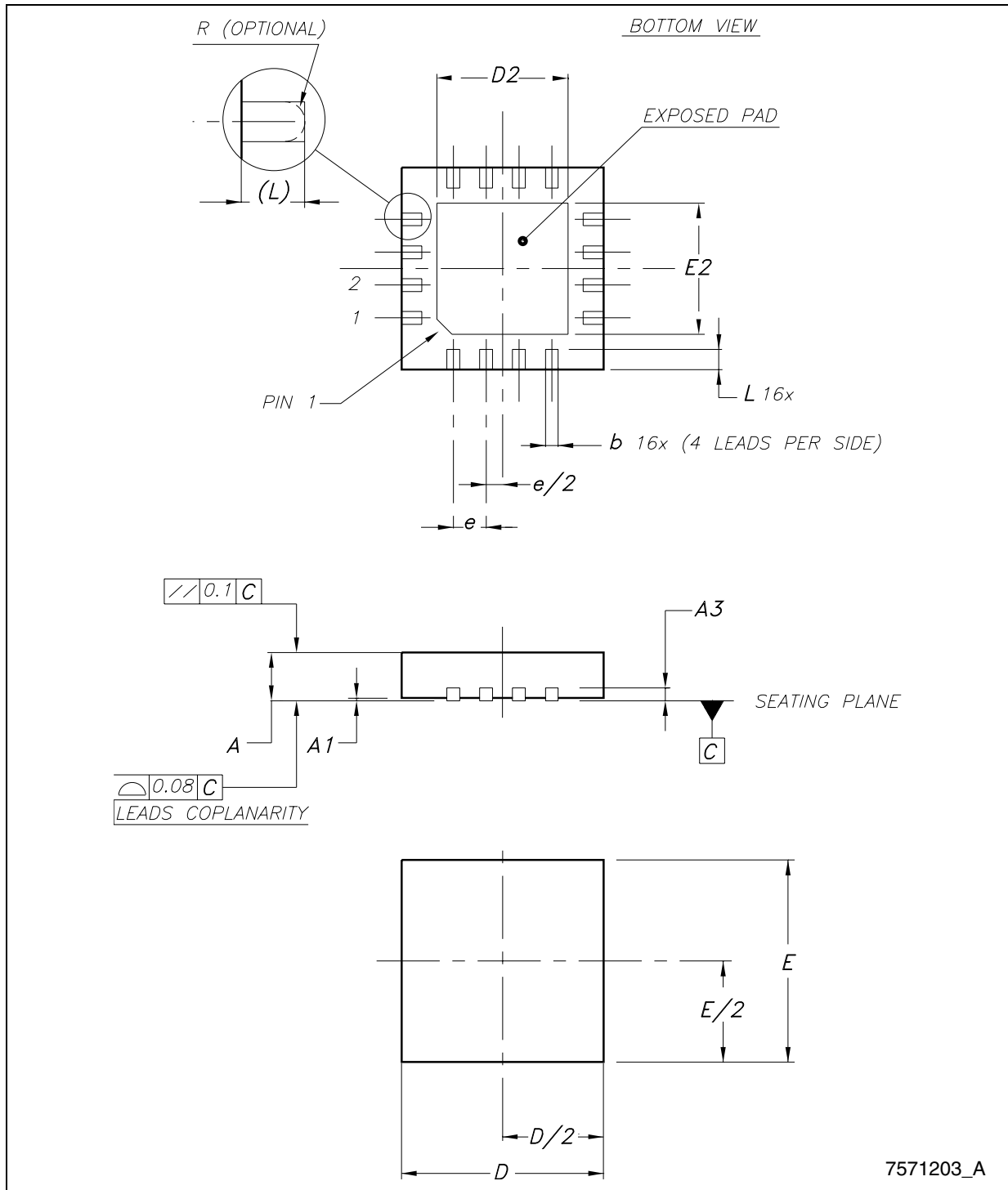

Tape & reel QFNxx/DFNxx (4x4) mechanical data

Dim.	mm.			inch.		
	Min.	Typ.	Max.	Min.	Typ.	Max.
A			330			12.992
C	12.8		13.2	0.504		0.519
D	20.2			0.795		
N	99		101	3.898		3.976
T			14.4			0.567
Ao		4.35			0.171	
Bo		4.35			0.171	
Ko		1.1			0.043	
Po		4			0.157	
P		8			0.315	

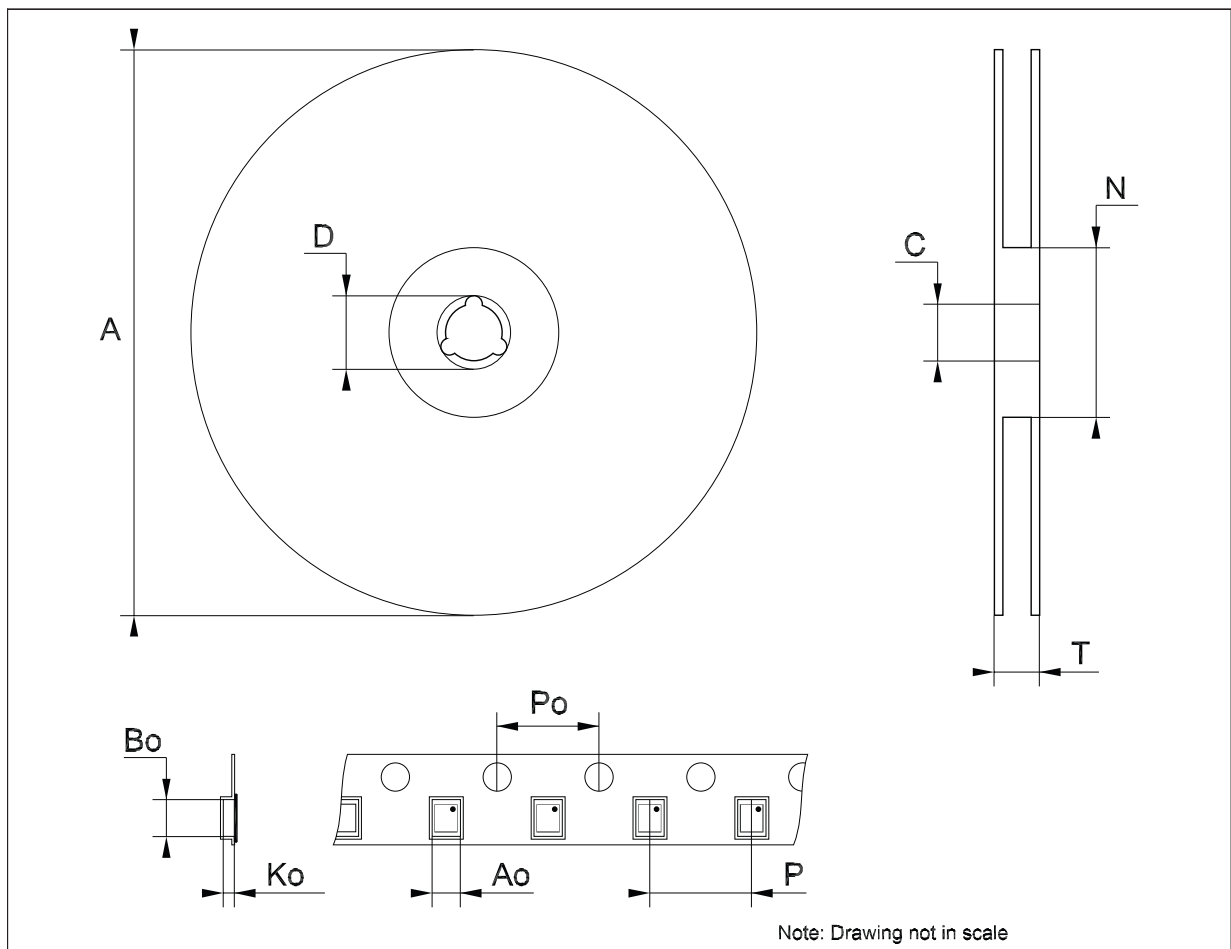
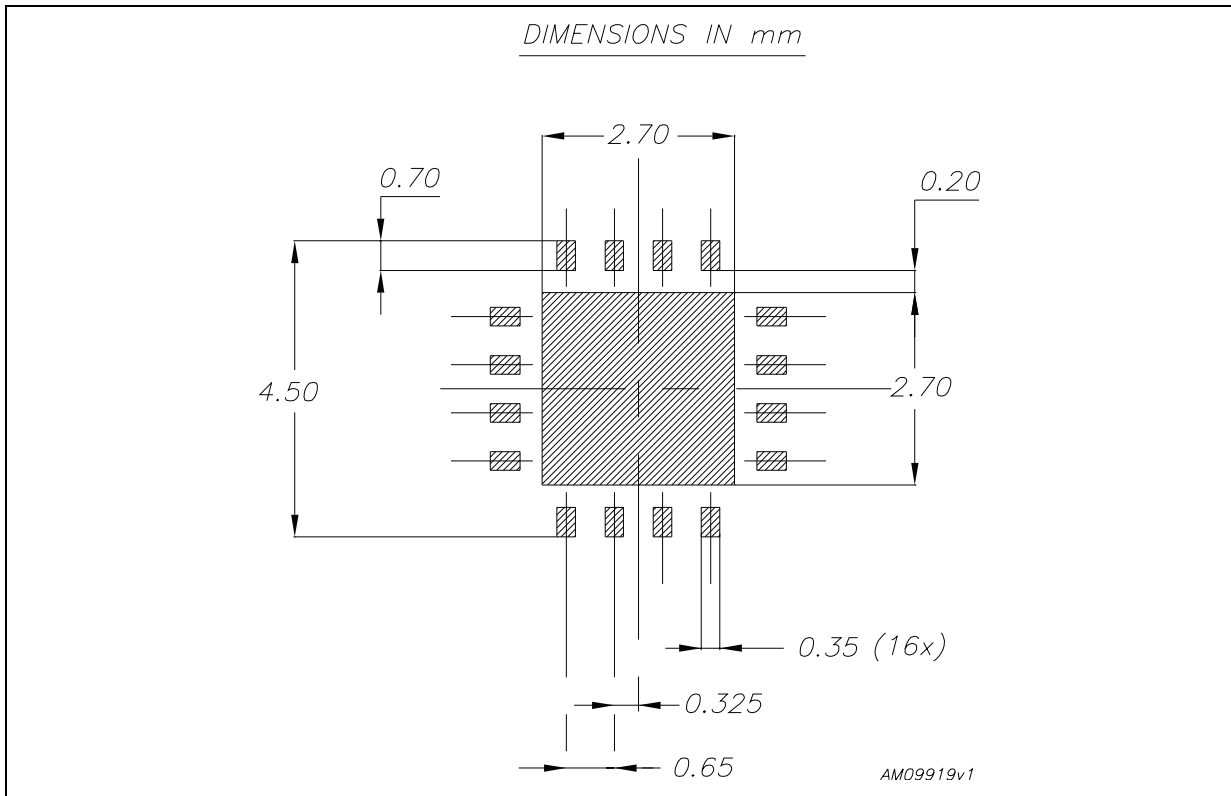

Figure 5. QFN16 (4 x 4 mm) recommended footprint



7 Revision history

Table 10. Document revision history

Date	Revision	Changes
30-Aug-2011	1	First release.

Please Read Carefully:

Information in this document is provided solely in connection with ST products. STMicroelectronics NV and its subsidiaries ("ST") reserve the right to make changes, corrections, modifications or improvements, to this document, and the products and services described herein at any time, without notice.

All ST products are sold pursuant to ST's terms and conditions of sale.

Purchasers are solely responsible for the choice, selection and use of the ST products and services described herein, and ST assumes no liability whatsoever relating to the choice, selection or use of the ST products and services described herein.

No license, express or implied, by estoppel or otherwise, to any intellectual property rights is granted under this document. If any part of this document refers to any third party products or services it shall not be deemed a license grant by ST for the use of such third party products or services, or any intellectual property contained therein or considered as a warranty covering the use in any manner whatsoever of such third party products or services or any intellectual property contained therein.

UNLESS OTHERWISE SET FORTH IN ST'S TERMS AND CONDITIONS OF SALE ST DISCLAIMS ANY EXPRESS OR IMPLIED WARRANTY WITH RESPECT TO THE USE AND/OR SALE OF ST PRODUCTS INCLUDING WITHOUT LIMITATION IMPLIED WARRANTIES OF MERCHANTABILITY, FITNESS FOR A PARTICULAR PURPOSE (AND THEIR EQUIVALENTS UNDER THE LAWS OF ANY JURISDICTION), OR INFRINGEMENT OF ANY PATENT, COPYRIGHT OR OTHER INTELLECTUAL PROPERTY RIGHT.

UNLESS EXPRESSLY APPROVED IN WRITING BY TWO AUTHORIZED ST REPRESENTATIVES, ST PRODUCTS ARE NOT RECOMMENDED, AUTHORIZED OR WARRANTED FOR USE IN MILITARY, AIR CRAFT, SPACE, LIFE SAVING, OR LIFE SUSTAINING APPLICATIONS, NOR IN PRODUCTS OR SYSTEMS WHERE FAILURE OR MALFUNCTION MAY RESULT IN PERSONAL INJURY, DEATH, OR SEVERE PROPERTY OR ENVIRONMENTAL DAMAGE. ST PRODUCTS WHICH ARE NOT SPECIFIED AS "AUTOMOTIVE GRADE" MAY ONLY BE USED IN AUTOMOTIVE APPLICATIONS AT USER'S OWN RISK.

Resale of ST products with provisions different from the statements and/or technical features set forth in this document shall immediately void any warranty granted by ST for the ST product or service described herein and shall not create or extend in any manner whatsoever, any liability of ST.

ST and the ST logo are trademarks or registered trademarks of ST in various countries.

Information in this document supersedes and replaces all information previously supplied.

The ST logo is a registered trademark of STMicroelectronics. All other names are the property of their respective owners.

© 2011 STMicroelectronics - All rights reserved

STMicroelectronics group of companies

Australia - Belgium - Brazil - Canada - China - Czech Republic - Finland - France - Germany - Hong Kong - India - Israel - Italy - Japan - Malaysia - Malta - Morocco - Philippines - Singapore - Spain - Sweden - Switzerland - United Kingdom - United States of America

www.st.com