



## STM6522

### Dual push-button Smart Reset™ with capacitor-adjustable setup delay

#### Features

- Dual Smart Reset™ push-button inputs with capacitor-adjustable extended reset setup delay ( $t_{SRC}$ )
- No power-on reset
- Dual  $\overline{RST}$  output, active-low, open-drain
- Fixed Smart Reset™ input logic voltage levels
- Broad operating voltage range 1.65 V to 5.5 V, inactive reset output levels valid down to 1.0 V
- Low supply current (1.5  $\mu$ A)
- Operating temperature:  
industrial grade  $-40\text{ }^{\circ}\text{C}$  to  $+85\text{ }^{\circ}\text{C}$
- TDFN8 package: 2 mm x 2 mm x 0.75 mm
- RoHS compliant

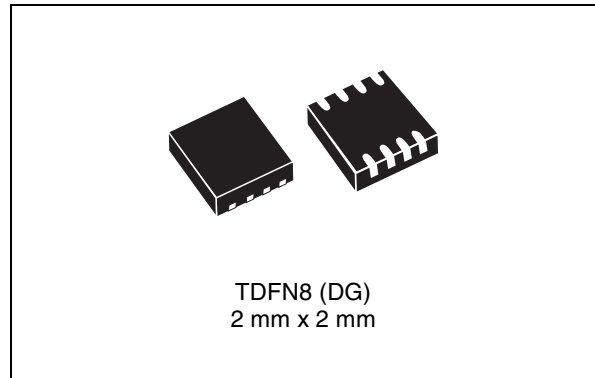

#### Applications

- Mobile phones, smartphones
- e-books
- MP3 players
- Games
- Portable navigation devices
- Any application that requires delayed reset push-button(s) response for improved system stability

# Contents

<b>1</b>	<b>Description</b> .....	<b>5</b>
<b>2</b>	<b>Pin descriptions</b> .....	<b>9</b>
2.1	Power supply ( $V_{CC}$ ) .....	9
2.2	Ground ( $V_{SS}$ ) .....	9
2.3	Primary Smart Reset™ input ( $\overline{SR0}$ ) .....	9
2.4	Secondary Smart Reset™ input ( $\overline{SR1}$ ) .....	9
2.5	Adjustable delay of Smart Reset™ (SRC pin) .....	10
2.6	Reset output ( $\overline{RST1}$ ) .....	10
2.7	Reset output ( $\overline{RST2}$ ) .....	10
<b>3</b>	<b>Typical operating characteristics</b> .....	<b>11</b>
<b>4</b>	<b>Maximum ratings</b> .....	<b>13</b>
<b>5</b>	<b>DC and AC parameters</b> .....	<b>14</b>
<b>6</b>	<b>Package mechanical data</b> .....	<b>16</b>
<b>7</b>	<b>Package footprint</b> .....	<b>18</b>
<b>8</b>	<b>Tape and reel information</b> .....	<b>19</b>
<b>9</b>	<b>Part numbering</b> .....	<b>22</b>
<b>10</b>	<b>Package marking</b> .....	<b>23</b>
<b>11</b>	<b>Revision history</b> .....	<b>24</b>

## List of tables

Table 1.	Signal names . . . . .	6
Table 2.	t <sub>SRC</sub> programmed by an ideal external capacitor . . . . .	10
Table 3.	Absolute maximum ratings . . . . .	13
Table 4.	Operating and measurement conditions . . . . .	14
Table 5.	DC and AC characteristics . . . . .	15
Table 6.	TDFN – 8-lead 2 x 2 x 0.75 mm, 0.5 mm pitch package mechanical data . . . . .	17
Table 7.	Parameters for landing pattern - TDFN – 8-lead 2 x 2 mm package . . . . .	18
Table 8.	Carrier tape dimensions . . . . .	19
Table 9.	Reel dimensions . . . . .	20
Table 10.	Ordering information scheme . . . . .	22
Table 11.	Package marking . . . . .	23
Table 12.	Document revision history . . . . .	24

## List of figures

Figure 1.	Logic diagram . . . . .	5
Figure 2.	Pin connections . . . . .	6
Figure 3.	Block diagram . . . . .	6
Figure 4.	Single-button Smart Reset™ typical hookup . . . . .	7
Figure 5.	Dual-button Smart Reset™ typical hookup. . . . .	7
Figure 6.	Timing waveforms. . . . .	8
Figure 7.	STM6522 timing . . . . .	9
Figure 8.	Supply current ( $I_{CC}$ ) vs. temperature . . . . .	11
Figure 9.	Smart Reset delay ( $t_{SRC}$ ) vs. temperature, $C_{SRC} = 0.6 \mu F$ . . . . .	11
Figure 10.	Reset timeout period ( $t_{REC}$ ) vs. temperature . . . . .	12
Figure 11.	Smart Reset™ input voltage threshold vs. temperature . . . . .	12
Figure 12.	AC testing input/output waveforms . . . . .	14
Figure 13.	TDFN – 8-lead 2 x 2 x 0.75 mm, 0.5 mm pitch package outline. . . . .	17
Figure 14.	Landing pattern - TDFN – 8-lead 2 x 2 mm without thermal pad . . . . .	18
Figure 15.	Carrier tape . . . . .	19
Figure 16.	Reel dimensions . . . . .	20
Figure 17.	Tape trailer/leader. . . . .	21
Figure 18.	Pin 1 orientation . . . . .	21
Figure 19.	Package marking, top view. . . . .	23

# 1 Description

The Smart Reset™ devices provide a useful feature that ensures that inadvertent short reset push-button closures do not cause system resets as the extended Smart Reset™ delay setup periods are implemented. Once the valid Smart Reset™ input levels and setup delay are met, the device generates an output reset pulse for a fixed timeout period ( $t_{REC}$ ).

The typical application hookup shows that either a single Smart Reset™ input, or both reset inputs can be connected to the applications interrupt and control both the interrupt pin and the hard reset functions. If the push-button is closed for a short time, the processor is only interrupted. If the system still does not respond properly, holding the push-button(s) for the extended setup time ( $t_{SRC}$ ) causes a hard reset of the processor. The Smart Reset™ feature helps significantly increase system stability and eliminates the need for a dedicated reset button.

The STM65xx family of Smart Reset™ devices consists of low-current microprocessor reset circuits targeted at applications such as MP3 players, portable navigation or mobile phones, generally any application that requires delayed reset push-button(s) response for improved system stability. The devices in the STM65xx Smart Reset™ family include various combinations of useful features for the targeted applications.

The STM6522 has two combined Smart Reset™ inputs ( $\overline{SR0}$  and  $\overline{SR1}$ ) with delayed reset setup time ( $t_{SRC}$ ) programmed by an external capacitor on the SRC pin.

Figure 1. Logic diagram

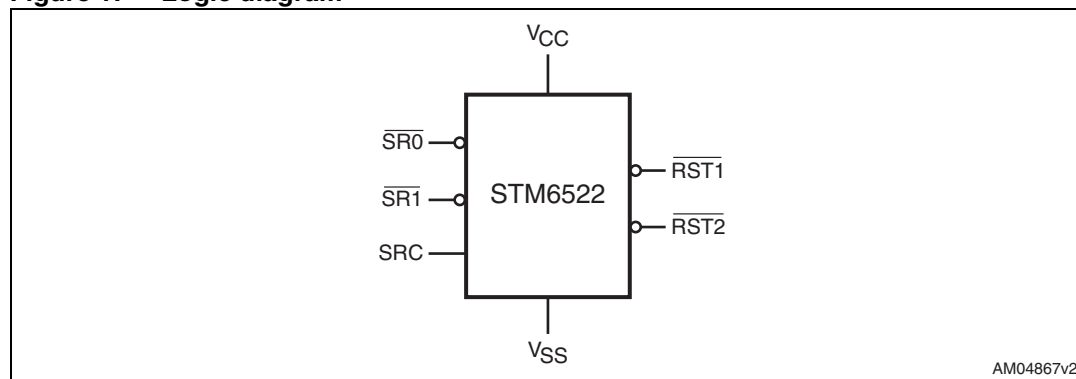

**Table 1. Signal names**

Symbol	Input/output	Description
$\overline{RST1}$	Output	Open-drain reset output, active-low, no internal pull-up resistor.
$\overline{RST2}$	Output	Open-drain reset output, active-low, no internal pull-up resistor.
$\overline{SR0}$	Input	Primary push-button Smart Reset™ input, active-low, fixed voltage input logic levels, no internal pull-up.
$\overline{SR1}$	Input	Secondary push-button Smart Reset™ input - combines with the primary push-button reset to provide setup delay time, active-low, fixed voltage input logic levels, no internal pull-up.
SRC	Input	Smart Reset™ input delay setup control: connect to an external capacitor to adjust the delay setup time ( $t_{SRC}$ ).
$V_{CC}$	Supply	Supply voltage input. Power supply for the device. A 0.1 $\mu F$ decoupling ceramic capacitor is recommended to be connected between $V_{CC}$ and $V_{SS}$ pins.
$V_{SS}$	Supply	Supply ground.
NC		No connect (not bonded); should be connected to $V_{SS}$ .

**Figure 2. Pin connections**

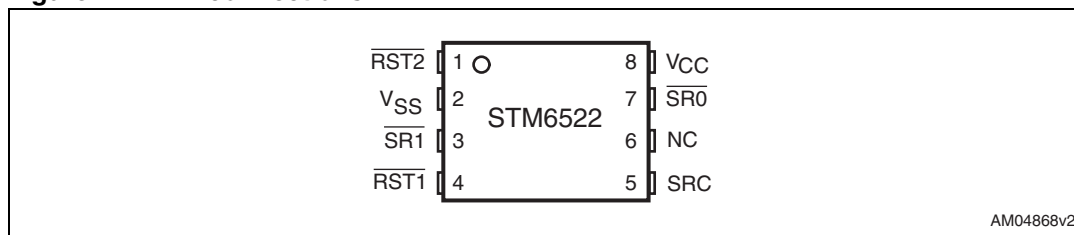

**Figure 3. Block diagram**

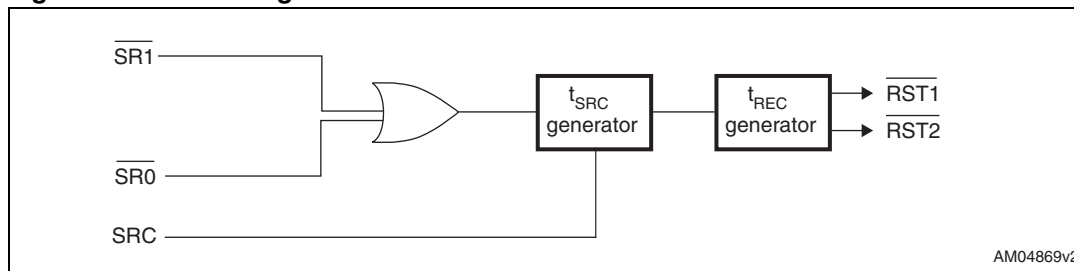

**Figure 4. Single-button Smart Reset™ typical hookup**

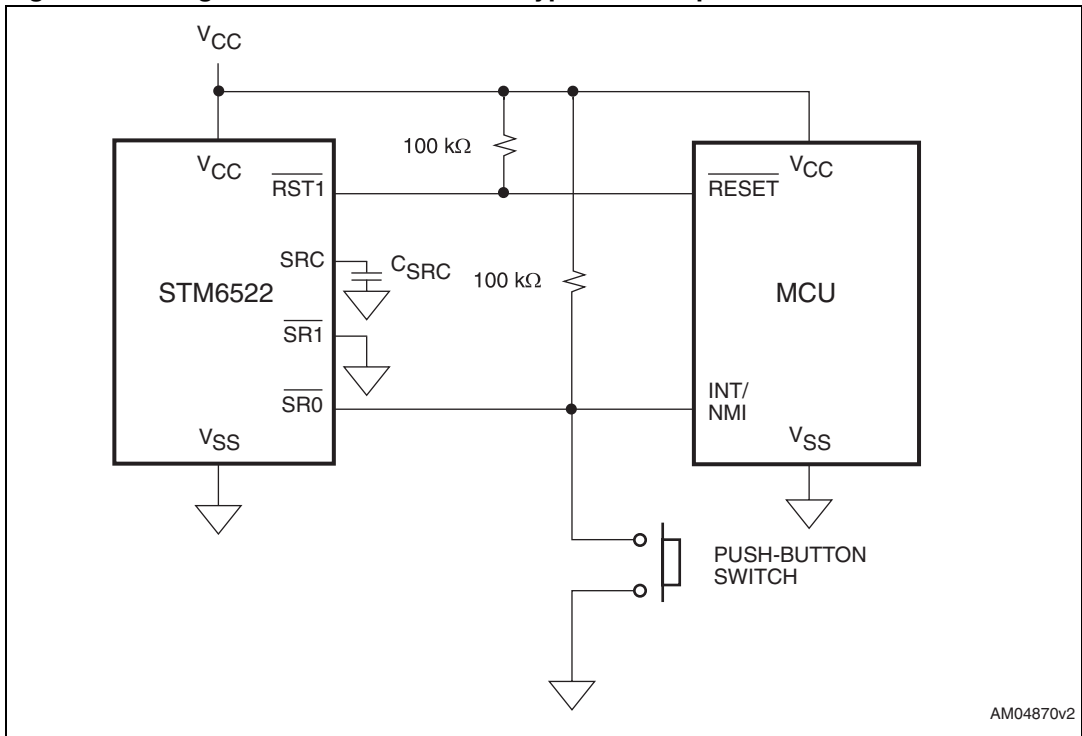

**Figure 5. Dual-button Smart Reset™ typical hookup**

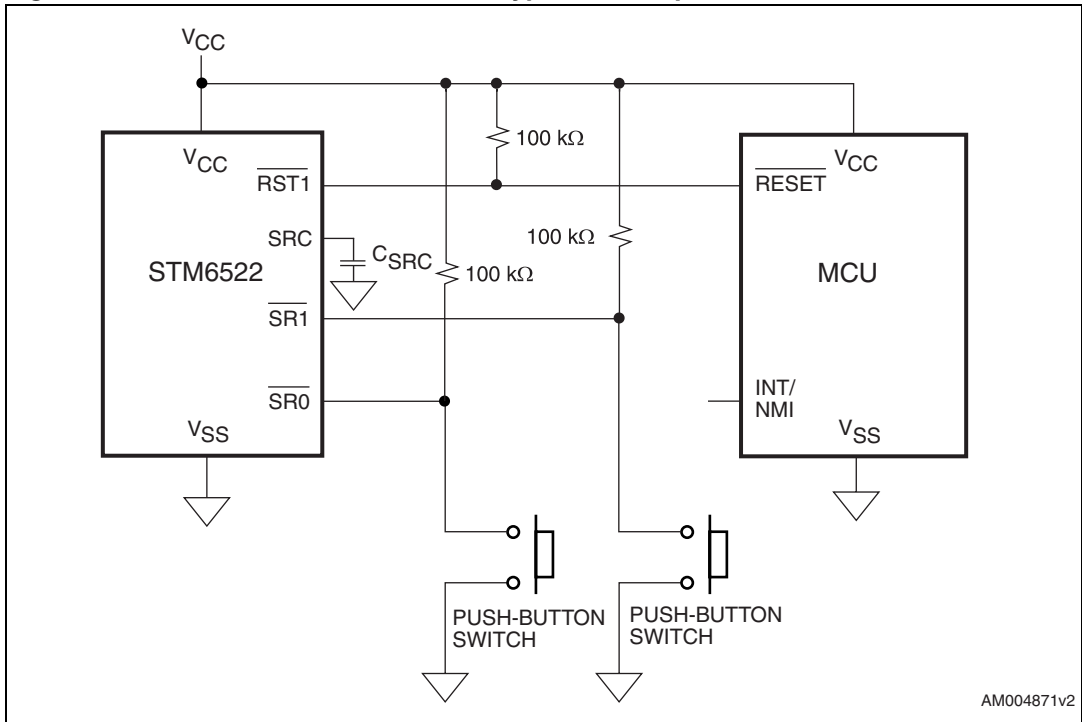
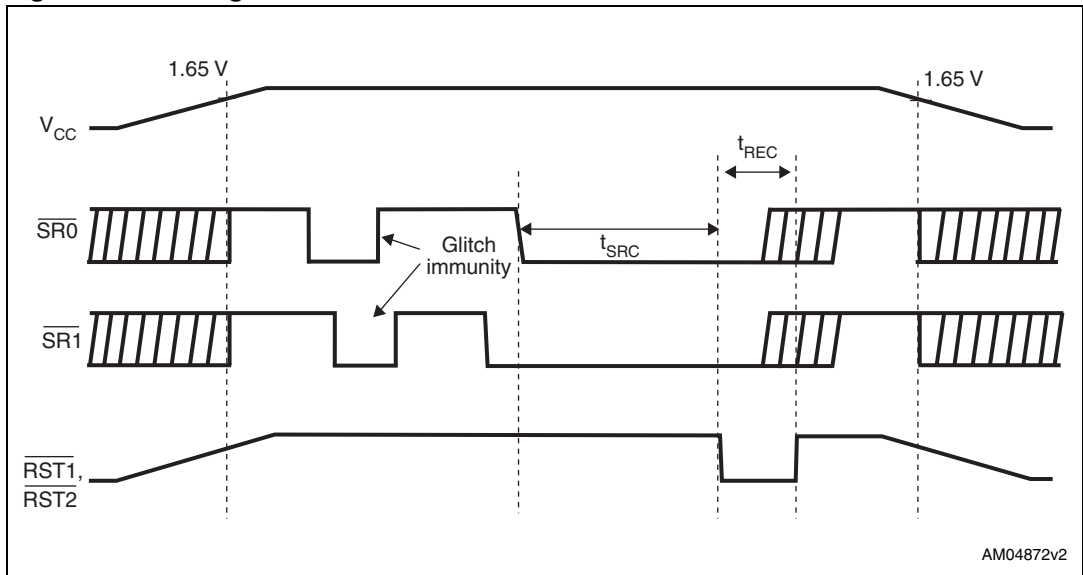

Figure 6. Timing waveforms



## 2 Pin descriptions

### 2.1 Power supply ( $V_{CC}$ )

This pin is used to provide the power to the device. A 0.1  $\mu\text{F}$  decoupling ceramic capacitor is recommended to be connected between  $V_{CC}$  and  $V_{SS}$  pins.

### 2.2 Ground ( $V_{SS}$ )

This is the supply ground for the device.

### 2.3 Primary Smart Reset™ input ( $\overline{\text{SR0}}$ )

The primary push-button Smart Reset™ input, active-low pin is connected to the push-button switch. The input logic voltage levels are set to a fixed voltage level and have no internal pull-up resistor.

### 2.4 Secondary Smart Reset™ input ( $\overline{\text{SR1}}$ )

The secondary push-button Smart Reset™ input, active-low pin is connected to the second push-button switch. The input logic voltage levels are set to a fixed voltage level and have no internal pull-up resistor. Keeping both Smart Reset™ inputs  $\overline{\text{SR0}}$  and  $\overline{\text{SR1}}$  active for longer than  $t_{\text{SRC}}$  activates the reset output pulse.

**Figure 7. STM6522 timing**

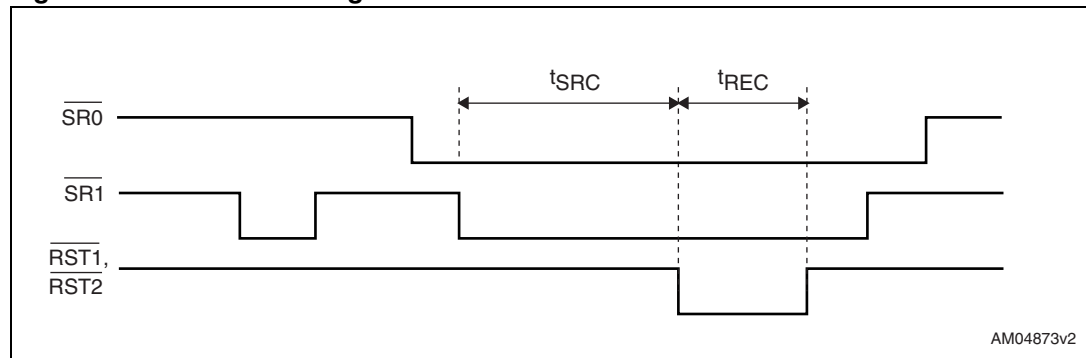

Reset is asserted “low” right after the Smart Reset™ setup delay ( $t_{\text{SRC}}$ ) has been met and returns to high after the  $t_{\text{REC}}$  period.

## 2.5 Adjustable delay of Smart Reset™ (SRC pin)

This pin controls the setup time before the push-button action is validated by the reset output. It is connected to an external capacitor ( $C_{SRC}$ ), which is tied to ground to provide the desired value of setup time ( $t_{SRC}$ ).

Selected calculated  $t_{SRC}$  and  $C_{SRC}$  examples are given in [Table 2](#). Refer also to [Table 5](#).

**Table 2.  $t_{SRC}$  programmed by an ideal external capacitor**

Calculated $C_{SRC}$ value [ $\mu$ F]	Setup delay $t_{SRC}$ [s] <sup>(1)(2)</sup>			Closest common $C_{SRC}$ value [ $\mu$ F]
	Min.	Typ.	Max.	
0.2	2	2.5	3.0	0.22
0.3	3	3.75	4.5	0.33
0.6	6	7.5	9	0.56
1	10	12.5	15	1

1. At 25 ° C. Example calculations based on an ideal capacitor. During application design and component selection it should be considered that the current flowing into the external  $t_{SRC}$  programming capacitor ( $C_{SRC}$ ) is on the order of 100 nA, therefore a low-leakage capacitor (ceramic or film capacitor) should be used and placed as close as possible to the SRC pin. Also an adequate low-leakage PCB environment should be ensured to prevent  $t_{SRC}$  accuracy from being affected. A recommended minimum value of  $C_{SRC}$  is 0.1  $\mu$ F.
2. In case of quickly repeated activations of  $t_{SRC}$  counter, an interval of 10 ms min. is needed between the activations to fully discharge  $C_{SRC}$ , so that the next  $t_{SRC}$  is as specified.

## 2.6 Reset output ( $\overline{RST1}$ )

This output is active-low, open-drain with no internal pull-up resistor.

## 2.7 Reset output ( $\overline{RST2}$ )

This output is active-low, open-drain with no internal pull-up resistor.

### 3 Typical operating characteristics

Figure 8. Supply current ( $I_{CC}$ ) vs. temperature

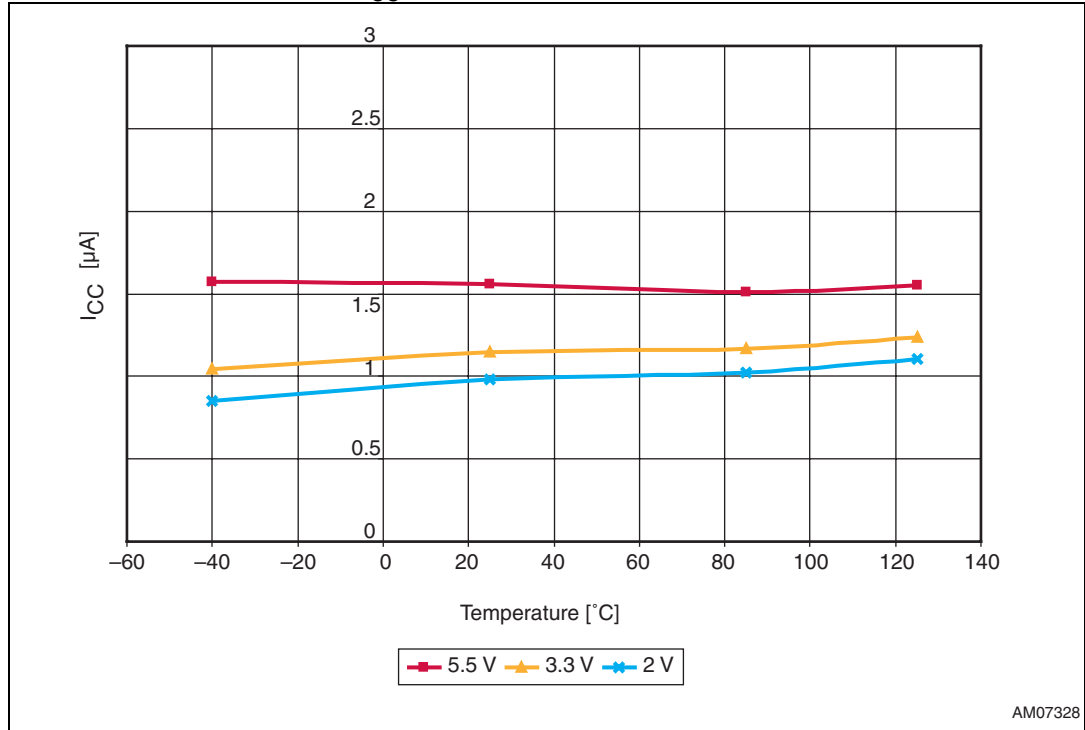

Figure 9. Smart Reset™ delay ( $t_{SRC}$ ) vs. temperature,  $C_{SRC} = 0.6 \mu$ F

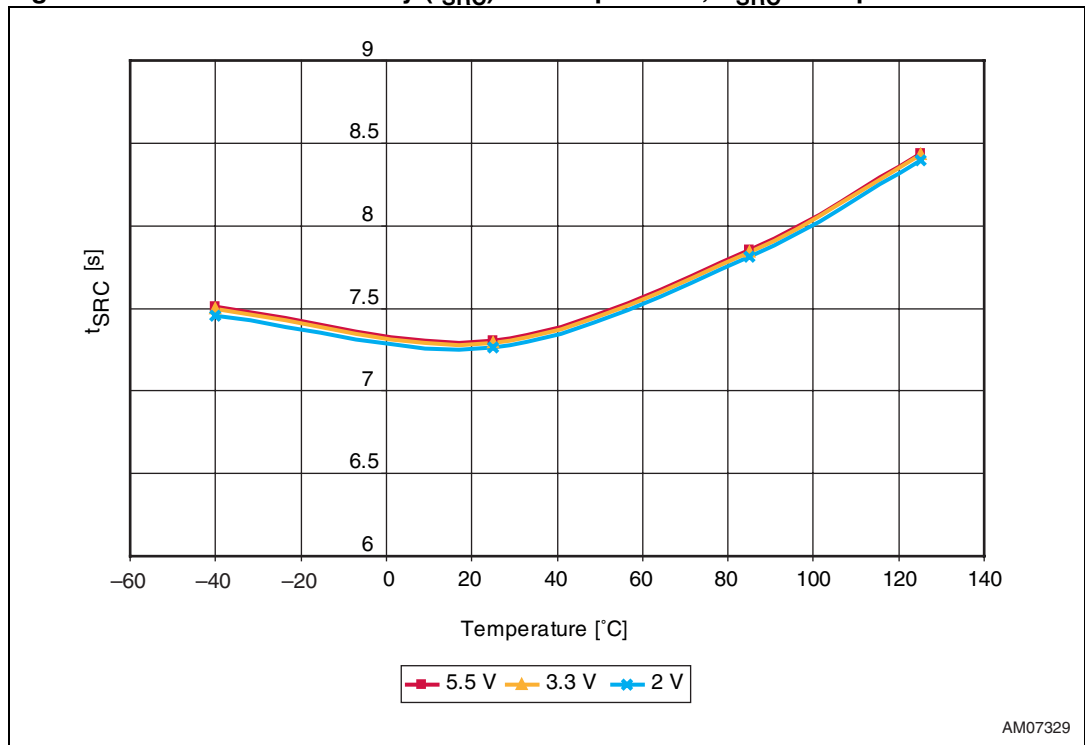

Figure 10. Reset timeout period ( $t_{REC}$ ) vs. temperature

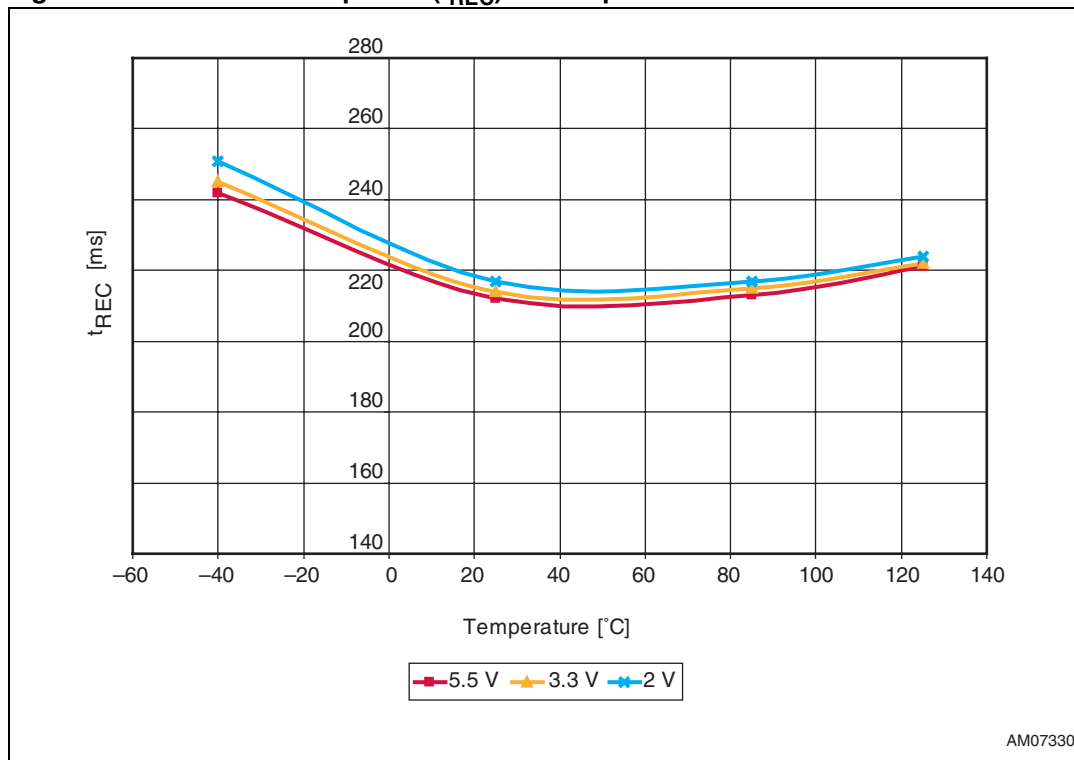
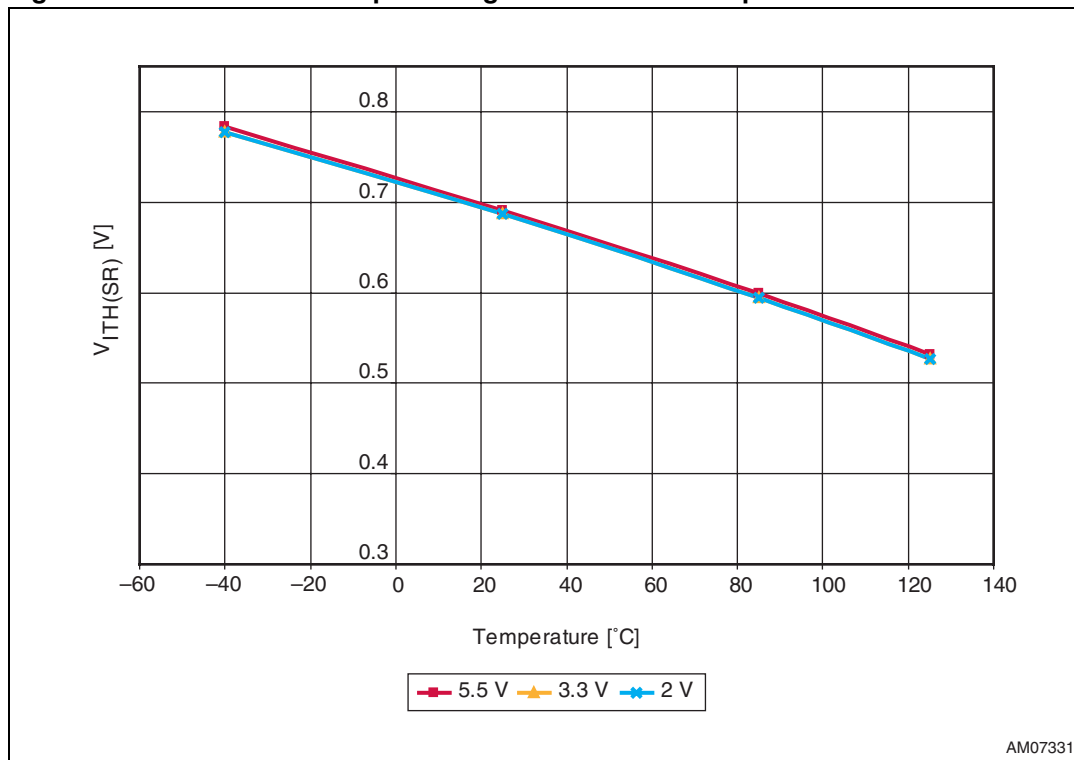

Figure 11. Smart Reset™ input voltage threshold vs. temperature



## 4 Maximum ratings

Stressing the device above the ratings listed in [Table 3: Absolute maximum ratings](#) may cause permanent damage to the device. These are stress ratings only and operation of the device at these or any other conditions above those indicated in [Table 4: Operating and measurement conditions](#) of this specification is not implied. Exposure to absolute maximum rating conditions for extended periods may affect device reliability. Refer also to the STMicroelectronics™ SURE program and other relevant quality documents.

**Table 3. Absolute maximum ratings**

Symbol	Parameter		Value	Unit
$T_{STG}$	Storage temperature ( $V_{CC}$ off)		-55 to +150	°C
$T_{SLD}^{(1)}$	Lead solder temperature for 10 seconds		260	°C
$\theta_{JA}$	Thermal resistance (junction to ambient)	TDFN8	149.0	°C/W
$V_{IO}$	Input or output voltage		-0.3 to 5.5	V
$V_{CC}$	Supply voltage		-0.3 to 7	V

1. Reflow at peak temperature of 260 °C. The time above 255 °C must not exceed 30 seconds.

## 5 DC and AC parameters

This section summarizes the operating measurement conditions, and the DC and AC characteristics of the device. The parameters in [Table 5: DC and AC characteristics](#) that follows, are derived from tests performed under the measurement conditions summarized in [Table 4: Operating and measurement conditions](#). Designers should check that the operating conditions in their circuit match the operating conditions when relying on the quoted parameters.

**Table 4. Operating and measurement conditions**

Parameter	Value	Unit
V <sub>CC</sub> supply voltage	1.65 to 5.5	V
Ambient operating temperature (T <sub>A</sub> )	-40 to +85	°C
Input rise and fall times	≤ 5	ns
Input pulse voltages	0.2 to 0.8 V <sub>CC</sub>	V
Input and output timing ref. voltages	0.3 to 0.7 V <sub>CC</sub>	V

**Figure 12. AC testing input/output waveforms**

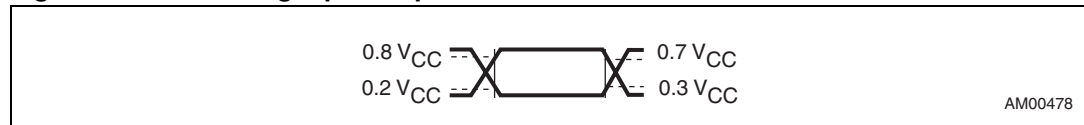

Table 5. DC and AC characteristics

Symbol	Parameter	Test conditions <sup>(1)</sup>	Min.	Typ. <sup>(2)</sup>	Max.	Unit
$V_{CC}$	Supply voltage range		1.65		5.5	V
$I_{CC}$	Supply current (inputs in their inactive state, neither $t_{REC}$ nor $t_{SRC}$ in progress)	$V_{CC} = 5.0$ V		2	3	$\mu$ A
		$V_{CC} = 3.0$ V		1.5		$\mu$ A
$V_{OL}$	Reset output voltage low (active-low reset asserted)	$V_{CC} \geq 4.5$ V, sinking 3.2 mA			0.3	V
		$V_{CC} \geq 3.3$ V, sinking 2.5 mA			0.3	V
		$V_{CC} \geq 1.65$ V, sinking 1 mA			0.3	V
$t_{REC}$	Reset timeout delay, factory programmed		140	210	280	ms
<b>Smart Reset™ inputs</b>						
$V_{IL}$	$\overline{SR0}$ , $\overline{SR1}$ input voltage low		$V_{SS} - 0.3$		0.3	V
$V_{IH}$	$\overline{SR0}$ , $\overline{SR1}$ input voltage high		0.85		5.5	V
$I_{LI(SR)}$	Input leakage current, $\overline{SRx}$ input		-1		+1	$\mu$ A
<b>Smart Reset™ delay</b>						
$t_{SRC}^{(3)}$	Delayed Smart Reset™ setup time. Refer to <a href="#">Table 2</a> .	$T_A = 25$ °C	$10 \times C_{SRC}$ ( $\mu$ F)	$12.5 \times C_{SRC}$ ( $\mu$ F)	$15 \times C_{SRC}$ ( $\mu$ F)	s

1. Valid for ambient operating temperature:  $T_A = -40$  to  $+85$  °C;  $V_{CC} = 1.65$  to  $5.5$  V (except where noted).

2. Typical value is at  $25$  °C and  $V_{CC} = 3.3$  V unless otherwise noted.

3. Input glitch immunity is equal to  $t_{SRC}$  (when both  $\overline{SR}$  inputs are low, otherwise infinite).

## 6 Package mechanical data

In order to meet environmental requirements, ST offers these devices in different grades of ECOPACK<sup>®</sup> packages, depending on their level of environmental compliance. ECOPACK<sup>®</sup> specifications, grade definitions and product status are available at: [www.st.com](http://www.st.com). ECOPACK<sup>®</sup> is an ST trademark.

Figure 13. TDFN – 8-lead 2 x 2 x 0.75 mm, 0.5 mm pitch package outline

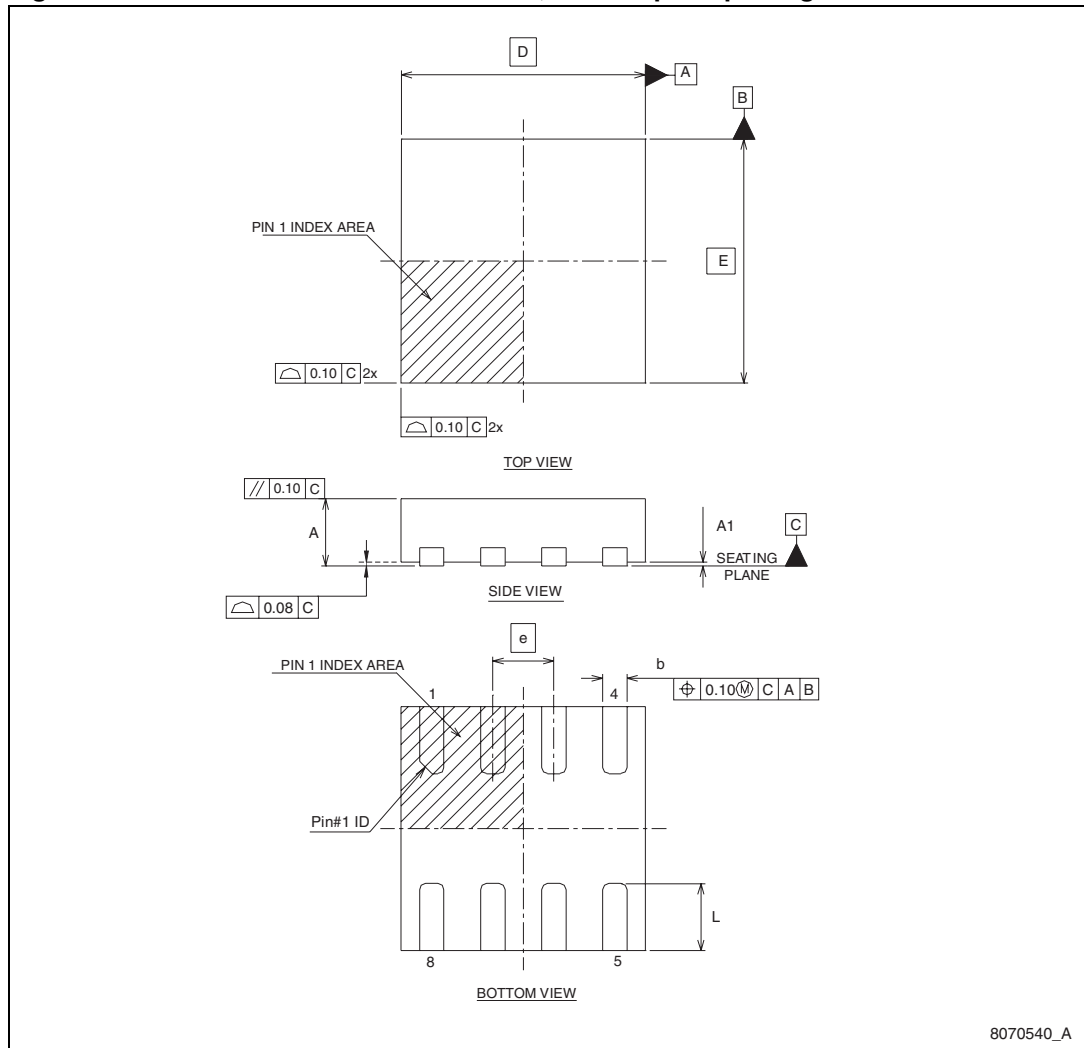

8070540\_A

Table 6. TDFN – 8-lead 2 x 2 x 0.75 mm, 0.5 mm pitch package mechanical data

Symbol	Dimension (mm)			Dimension (inches)		
	Min.	Nom.	Max.	Min.	Nom.	Max.
A	0.70	0.75	0.80	0.028	0.030	0.031
A1	0.00	0.02	0.05	0.000	0.001	0.002
b	0.15	0.20	0.25	0.006	0.008	0.010
D BSC	1.9	2.00	2.1	0.075	0.079	0.083
E BSC	1.9	2.00	2.1	0.075	0.079	0.083
e		0.50			0.020	
L	0.45	0.55	0.65	0.018	0.022	0.026

## 7 Package footprint

Figure 14. Landing pattern - TDFN – 8-lead 2 x 2 mm without thermal pad

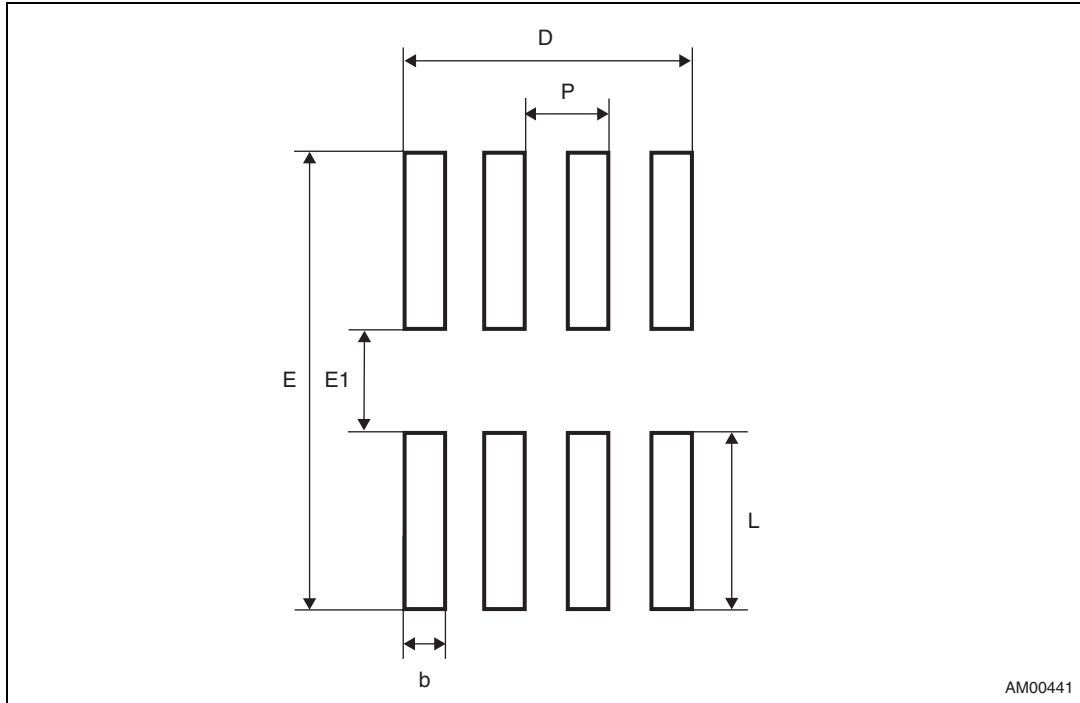

Table 7. Parameters for landing pattern - TDFN – 8-lead 2 x 2 mm package

Parameter	Description	Dimension (mm)		
		Min.	Nom.	Max.
L	Contact length	1.05	—	1.15
b	Contact width	0.25	—	0.30
E	Max. land pattern Y-direction	—	2.85	—
E1	Contact gap spacing	—	0.65	—
D	Max. land pattern X-direction	—	1.75	—
P	Contact pitch	—	0.5	—

## 8 Tape and reel information

Figure 15. Carrier tape

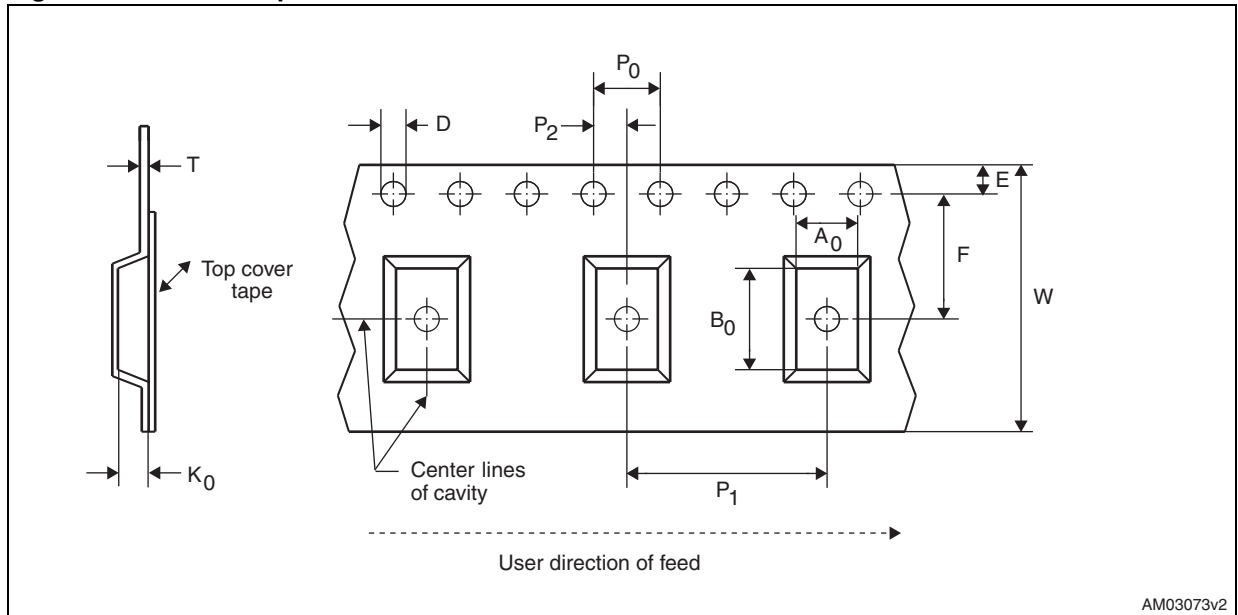

Table 8. Carrier tape dimensions

Package	W	D	E	P <sub>0</sub>	P <sub>2</sub>	F	A <sub>0</sub>	B <sub>0</sub>	K <sub>0</sub>	P <sub>1</sub>	T	Unit	Bulk qty.
TDFN8	8.00 +0.30 -0.10	1.50 +0.10/ -0.00	1.75 ±0.10	4.00 ±0.10	2.00 ±0.10	3.50 ±0.05	2.30 ±0.05	2.30 ±0.05	1.00 ±0.05	4.00 ±0.10	0.250 ±0.05	mm	3000

Figure 16. Reel dimensions

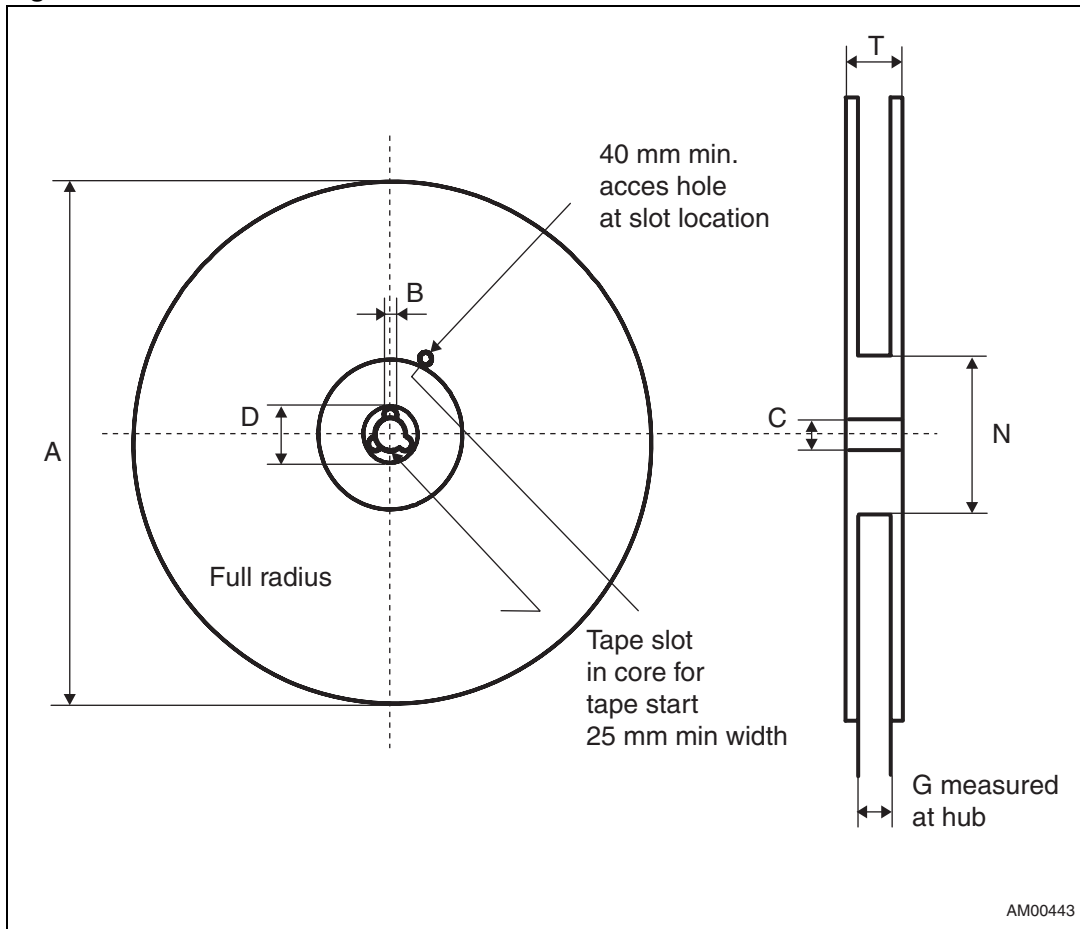
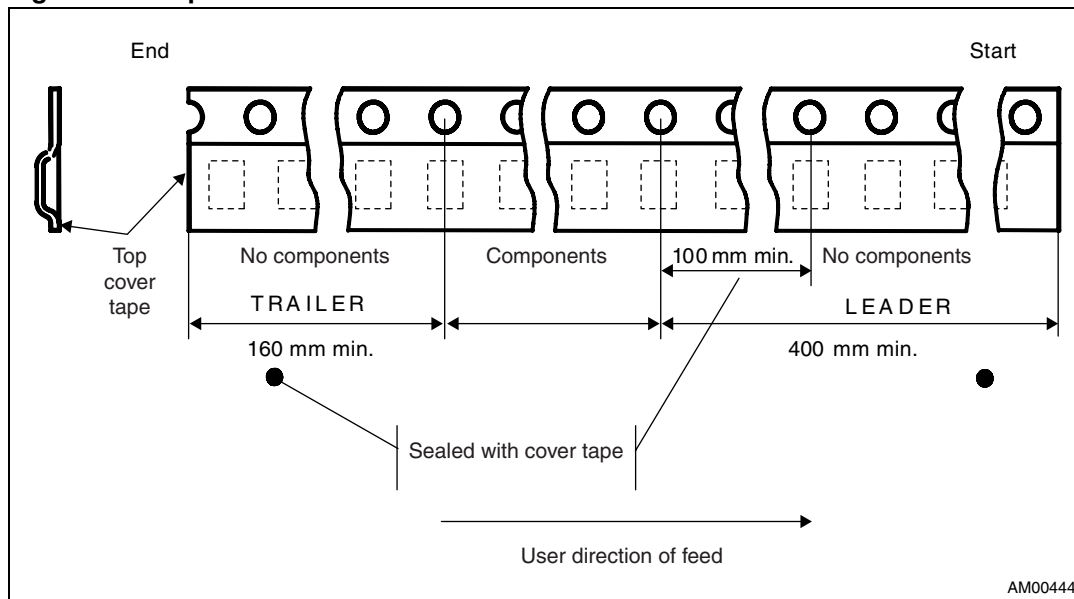

Table 9. Reel dimensions

Tape sizes	A max.	B min.	C	D min.	N min.	G	T max.
8 mm	180 (7 inches)	1.50	13.0 +/- 0.20	20.20	60	8.4 +2/-0	14.40

Figure 17. Tape trailer/leader



AM00444

Figure 18. Pin 1 orientation

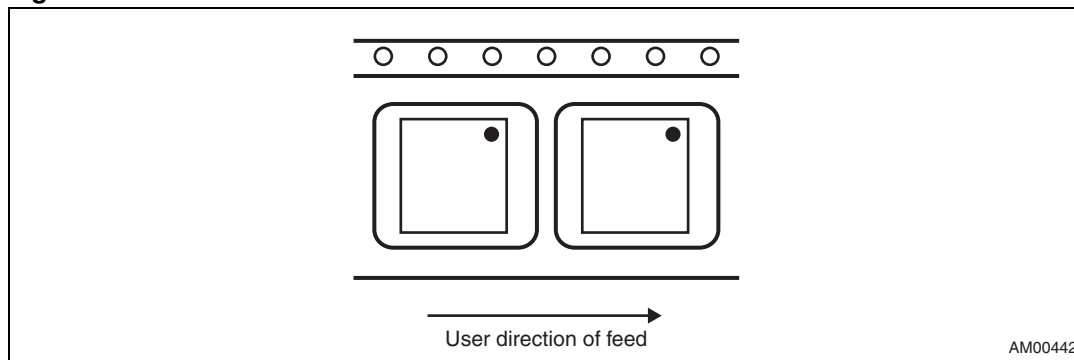

AM00442

- Note: 1 Drawings are not to scale.  
 2 All dimensions are in mm, unless otherwise noted.

## 9 Part numbering

**Table 10. Ordering information scheme**

Example:	STM6522	A	A	A	A	DG	6	F
<b>Device type</b>								
STM6522								
<b>V<sub>CC</sub> monitoring, power-on reset</b>								
A = no V <sub>CC</sub> monitoring, no power-on reset								
<b>Smart Reset™ setup delay (t<sub>SRC</sub>); presence of internal input pull-up on all Smart Reset™ inputs (<math>\overline{SRx}</math>)</b>								
A = user-programmed (external capacitor); no input pull-up								
<b>Output type</b>								
A = both $\overline{RST1}$ and $\overline{RST2}$ open-drain, no pull-up, active-low								
<b>Reset timeout period (t<sub>REC</sub>)</b>								
A = 140 ms min.								
<b>Package</b>								
DG = TDFN8 2 x 2 x 0.75 mm, 0.5 mm pitch								
<b>Temperature range</b>								
6 = -40 °C to +85 °C								
<b>Shipping method</b>								
F = ECOPACK® package, tape and reel								

For device options currently available refer to [Table 11](#). For other options, or for more information on any aspect of this device, please contact the ST sales office nearest you.

# 10 Package marking

**Table 11. Package marking**

Part number	t <sub>SRC</sub> delay control	Smart Reset™ inputs <sup>(1)</sup>	Power-on reset, V <sub>CC</sub> monitoring	$\overline{\text{RST1}}$ output <sup>(1)</sup>	$\overline{\text{RST2}}$ output <sup>(1)</sup>	t <sub>REC</sub> option	Topmark
STM6522AAAADG6F	C <sub>SRC</sub>	AL	—	AL, OD	AL, OD	A	CAL, AAL

1. AL = active-low, AH = active-high, PU = with internal pull-up resistor, OD = open-drain.

**Figure 19. Package marking, top view**

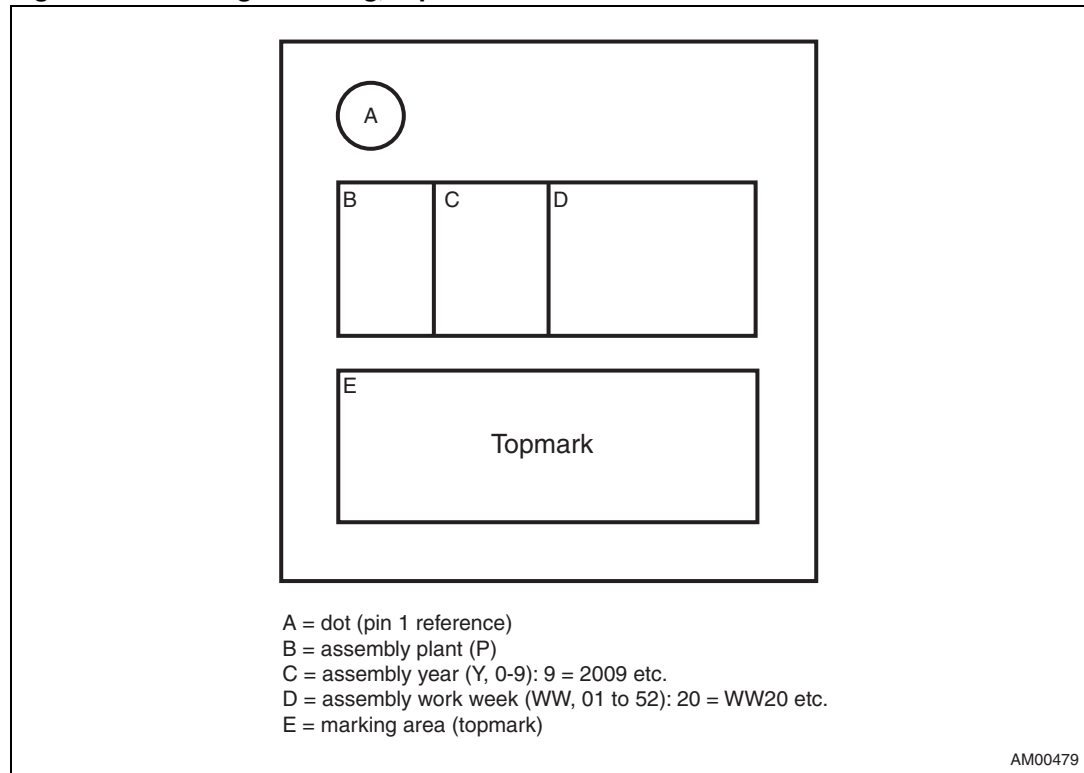

# 11 Revision history

**Table 12. Document revision history**

Date	Revision	Changes
03-Feb-2010	1	Initial release.
10-May-2010	2	Updated title, <i>Features, Applications, Section 1, Figure 1, Table 1, Figure 2, Figure 3, Figure 4, Figure 5, Figure 6, Section 2.4, Figure 7</i> , note 1 below <i>Table 2, Section 2.6</i> , added <i>Section 2.7, Section 3, Table 5, Table 6, Table 7, Table 10, Section 8, Table 11</i> .
09-Jan-2012	3	Updated <i>Table 3, Table 5, Table 11</i> and Disclaimer, minor text corrections throughout document.

**Please Read Carefully:**

Information in this document is provided solely in connection with ST products. STMicroelectronics NV and its subsidiaries ("ST") reserve the right to make changes, corrections, modifications or improvements, to this document, and the products and services described herein at any time, without notice.

All ST products are sold pursuant to ST's terms and conditions of sale.

Purchasers are solely responsible for the choice, selection and use of the ST products and services described herein, and ST assumes no liability whatsoever relating to the choice, selection or use of the ST products and services described herein.

No license, express or implied, by estoppel or otherwise, to any intellectual property rights is granted under this document. If any part of this document refers to any third party products or services it shall not be deemed a license grant by ST for the use of such third party products or services, or any intellectual property contained therein or considered as a warranty covering the use in any manner whatsoever of such third party products or services or any intellectual property contained therein.

**UNLESS OTHERWISE SET FORTH IN ST'S TERMS AND CONDITIONS OF SALE ST DISCLAIMS ANY EXPRESS OR IMPLIED WARRANTY WITH RESPECT TO THE USE AND/OR SALE OF ST PRODUCTS INCLUDING WITHOUT LIMITATION IMPLIED WARRANTIES OF MERCHANTABILITY, FITNESS FOR A PARTICULAR PURPOSE (AND THEIR EQUIVALENTS UNDER THE LAWS OF ANY JURISDICTION), OR INFRINGEMENT OF ANY PATENT, COPYRIGHT OR OTHER INTELLECTUAL PROPERTY RIGHT.**

**UNLESS EXPRESSLY APPROVED IN WRITING BY TWO AUTHORIZED ST REPRESENTATIVES, ST PRODUCTS ARE NOT RECOMMENDED, AUTHORIZED OR WARRANTED FOR USE IN MILITARY, AIR CRAFT, SPACE, LIFE SAVING, OR LIFE SUSTAINING APPLICATIONS, NOR IN PRODUCTS OR SYSTEMS WHERE FAILURE OR MALFUNCTION MAY RESULT IN PERSONAL INJURY, DEATH, OR SEVERE PROPERTY OR ENVIRONMENTAL DAMAGE. ST PRODUCTS WHICH ARE NOT SPECIFIED AS "AUTOMOTIVE GRADE" MAY ONLY BE USED IN AUTOMOTIVE APPLICATIONS AT USER'S OWN RISK.**

Resale of ST products with provisions different from the statements and/or technical features set forth in this document shall immediately void any warranty granted by ST for the ST product or service described herein and shall not create or extend in any manner whatsoever, any liability of ST.

ST and the ST logo are trademarks or registered trademarks of ST in various countries.

Information in this document supersedes and replaces all information previously supplied.

The ST logo is a registered trademark of STMicroelectronics. All other names are the property of their respective owners.

© 2012 STMicroelectronics - All rights reserved

STMicroelectronics group of companies

Australia - Belgium - Brazil - Canada - China - Czech Republic - Finland - France - Germany - Hong Kong - India - Israel - Italy - Japan - Malaysia - Malta - Morocco - Philippines - Singapore - Spain - Sweden - Switzerland - United Kingdom - United States of America

[www.st.com](http://www.st.com)