



STM6520

Dual push-button Smart Reset™ with push-button controlled output delay

Features

- Dual Smart Reset™ push-button inputs, with user-selectable extended reset setup delay (by two-state input logic): $t_{SRC} = 6, 10 \text{ s}$ (min.)
- Push-button controlled reset pulse duration (no fixed nor minimum pulse width guaranteed)
- No power-on reset
- Dual reset outputs
 - $\overline{RST1}$ - active-low, open-drain
 - RST2 - active-high, push-pull
- Fixed Smart Reset™ input logic voltage levels
- Broad operating voltage range 1.65 V to 5.5 V, inactive reset output levels valid down to 1.0 V
- Low supply current 1.5 μA
- Operating temperature: $-30 \text{ }^\circ\text{C}$ to $+85 \text{ }^\circ\text{C}$
- TDFN8 package: 2 mm x 2 mm x 0.75 mm
- RoHS compliant

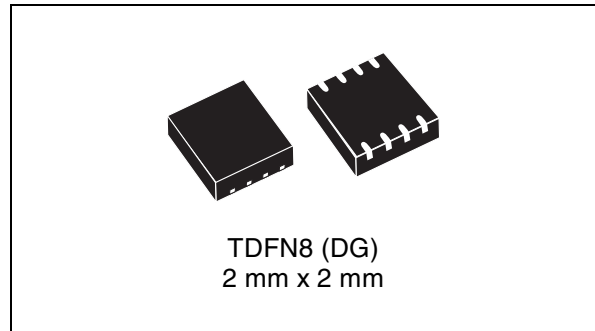

Applications

- Mobile phones, smartphones
- e-books
- MP3 players
- Games
- Portable navigation devices
- Any application that requires delayed reset push-button(s) response for improved system stability

Contents

1	Description	5
2	Device overview	6
3	Pin descriptions	7
3.1	Power supply (V_{CC})	7
3.2	Ground (V_{SS})	7
3.3	Smart Reset™ inputs ($\overline{SR0}$, $\overline{SR1}$)	7
3.4	User-selectable Smart Reset™ delay (DSR)	7
3.5	Reset outputs ($\overline{RST1}$, RST2)	7
4	Typical application diagram	8
5	Typical operating characteristics	10
6	Maximum rating	11
7	DC and AC parameters	12
8	Package mechanical data	14
9	Package footprint	16
10	Tape and reel information	17
11	Ordering information	20
12	Package marking information	21
13	Revision history	22

List of tables

Table 1.	Signal names	6
Table 2.	Absolute maximum ratings	11
Table 3.	Operating and measurement conditions	12
Table 4.	DC and AC characteristics	13
Table 5.	TDFN – 8-lead 2 x 2 x 0.75 mm, 0.5 mm package mechanical data	15
Table 6.	Parameter for landing pattern - TDFN – 8-lead 2 x 2 mm package	16
Table 7.	Carrier tape dimensions	17
Table 8.	Reel dimensions	18
Table 9.	Ordering information scheme	20
Table 10.	Package marking	21
Table 11.	Document revision history	22

List of figures

Figure 1.	Logic diagram	5
Figure 2.	Pin connections	5
Figure 3.	Block diagram	7
Figure 4.	$\overline{\text{RST1}}$ output used for microcontroller reset	8
Figure 5.	RST2 used for interrupting system power	8
Figure 6.	Timing waveforms	9
Figure 7.	Undervoltage condition	9
Figure 8.	Supply current (I_{CC}) vs. temperature	10
Figure 9.	Smart Reset™ delay (t_{SRC}) vs. temperature, $\text{DSR} = V_{\text{SS}}$	10
Figure 10.	AC testing input/output waveforms	12
Figure 11.	TDFN - 8-lead, 2 x 2 mm package outline	14
Figure 12.	Landing pattern - TDFN – 8-lead 2 x 2 mm without thermal pad	16
Figure 13.	Carrier tape	17
Figure 14.	Reel dimensions	18
Figure 15.	Tape trailer/leader	19
Figure 16.	Pin 1 orientation	19
Figure 17.	Package marking area, top view	21

1 Description

The Smart Reset™ devices provide a useful feature that ensures inadvertent short reset push-button closures do not cause system resets. This is done by implementing extended Smart Reset™ input delay time (t_{SRC}) and combined push-button inputs, which together ensures a safe reset and eliminates the need for a specific dedicated reset button.

This reset configuration provides versatility and allows the application to discriminate between a software generated interrupt and a hard system reset. When the input push-buttons are connected to microcontroller interrupt inputs, and are closed for a short time, the processor can only be interrupted. If the system still does not respond properly, continuing to keep the push-buttons closed for the extended setup time t_{SRC} causes a hard reset of the processor through the reset outputs.

The STM6520 has two combined delayed Smart Reset™ inputs ($\overline{SR0}$, $\overline{SR1}$) with two user-selectable delayed Smart Reset™ setup time (t_{SRC}) options of 7.5 s and 12.5 s typ., selected by a dual-state Smart Reset™ DSR input pin. When DSR is connected to ground, $t_{SRC} = 7.5$ s, when connected to V_{CC} , $t_{SRC} = 12.5$ s (typ.). There are two reset outputs, both going active simultaneously after both of the Smart Reset™ inputs were held active for the selected t_{SRC} delay time. The outputs remain asserted until either or both inputs go to inactive logic level (for this device the output reset pulse duration is fully push-button controlled, meaning neither fixed nor minimum reset pulse width, nor power-on reset pulse is implemented). The first reset output, $\overline{RST1}$, is active-low, open-drain; the second reset output, RST2, is active-high, push-pull. The device fully operates over a broad V_{CC} range 1.65 to 5.5 V. Below 1.575 V typ. the inputs are ignored and outputs are deasserted; the deasserted reset output levels are then valid down to 1.0 V.

Figure 1. Logic diagram

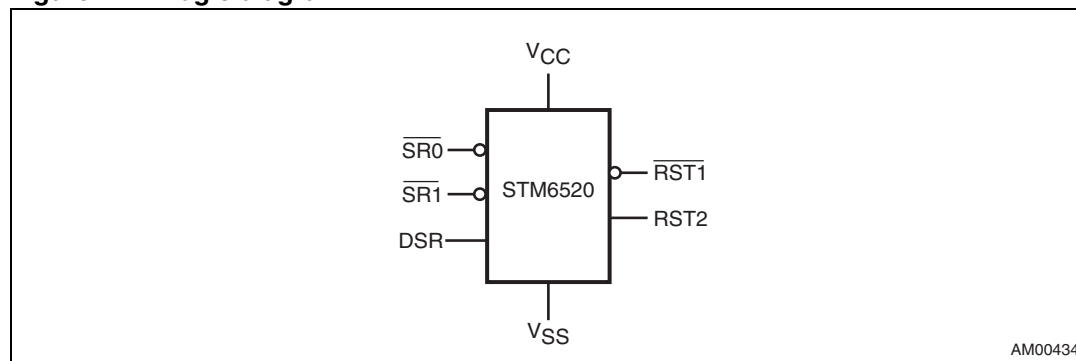

AM00434

Figure 2. Pin connections

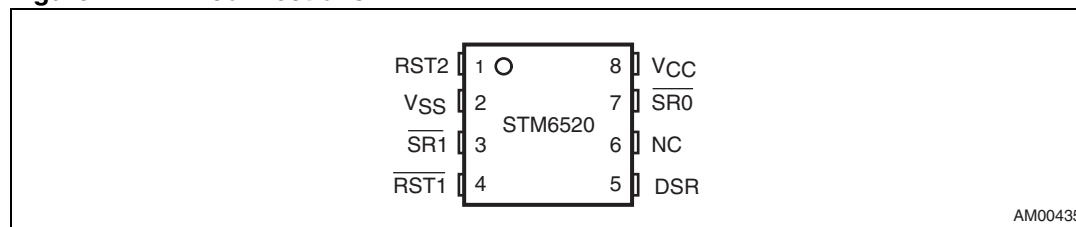

AM00435

2 Device overview

Table 1. Signal names

Symbol	Input/output	Description
$\overline{\text{RST1}}$	Output	First reset output, active-low, open-drain.
RST2	Output	Second reset output, active-high, push-pull.
$\overline{\text{SR0}}$	Input	Primary push-button Smart Reset™ input. Active-low.
$\overline{\text{SR1}}$	Input	Secondary push-button Smart Reset™ input. Active-low.
DSR	Input	A dual-state Smart Reset™ input delay selection pin. When connected to ground, $t_{\text{SRC}} = 7.5 \text{ s}$; when connected to V_{CC} , $t_{\text{SRC}} = 12.5 \text{ s}$ (typ.). DSR is a DC-type input, intended to be either permanently grounded or permanently connected to V_{CC} .
V_{CC}	Supply voltage	Positive supply voltage for the device. A 0.1 μF decoupling ceramic capacitor is recommended to be connected between V_{CC} and V_{SS} pins.
V_{SS}	Supply ground	Ground
NC		No connect (not bonded; should be connected to V_{SS}).

3 Pin descriptions

3.1 Power supply (V_{CC})

This pin is used to provide power to the Smart Reset™ device. A 0.1 μF ceramic decoupling capacitor is recommended to be connected between the V_{CC} and V_{SS} pins, as close to the STM6520 device as possible.

3.2 Ground (V_{SS})

This is the ground pin for the device.

3.3 Smart Reset™ inputs ($\overline{SR0}$, $\overline{SR1}$)

Push-button Smart Reset™ inputs, active-low. Both inputs need to be asserted simultaneously for at least t_{SRC} to activate the reset outputs.

3.4 User-selectable Smart Reset™ delay (DSR)

An input that allows the user to program the setup time (t_{SRC}) for which both the push-buttons need to be pressed to activate the reset outputs. Controlled by different voltage levels on the DSR pin: when connected to ground, $t_{SRC} = 7.5$ s, when connected to V_{CC} , $t_{SRC} = 12.5$ s (typ.). DSR is a DC-type input, intended to be either permanently grounded or permanently connected to V_{CC} .

3.5 Reset outputs ($\overline{RST1}$, RST2)

$\overline{RST1}$ is active-low, open-drain, RST2 active-high, push-pull. Neither fixed nor minimum output reset pulse duration, nor power-on reset is implemented. Releasing any of the push-buttons while reset outputs are active, causes both outputs to deassert.

Figure 3. Block diagram

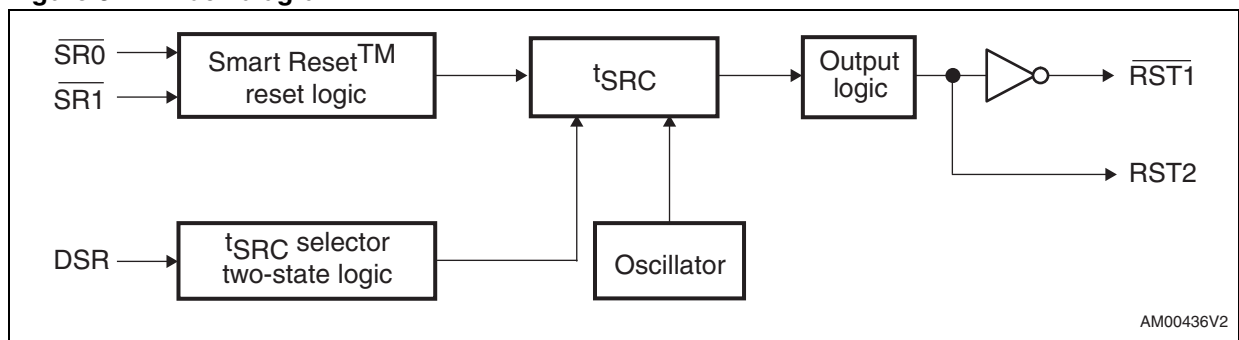

4 Typical application diagram

Figure 4. $\overline{\text{RST1}}$ output used for microcontroller reset

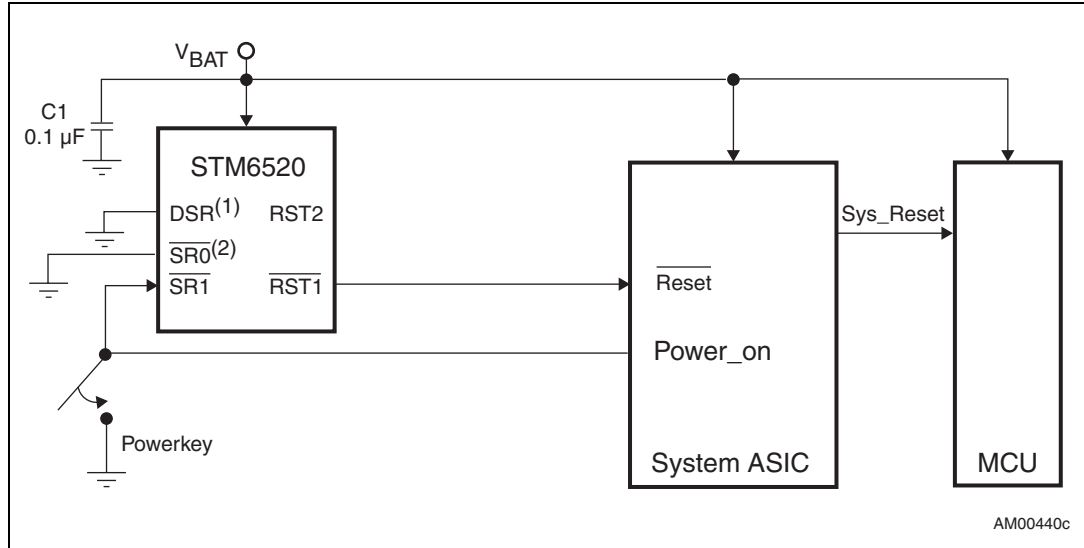

1. DSR pin (pin 5) must be tied to V_{CC} or V_{SS} .
2. When only one Smart Reset™ input is used, connect the unused one permanently to V_{SS} .

Figure 5. RST2 used for interrupting system power

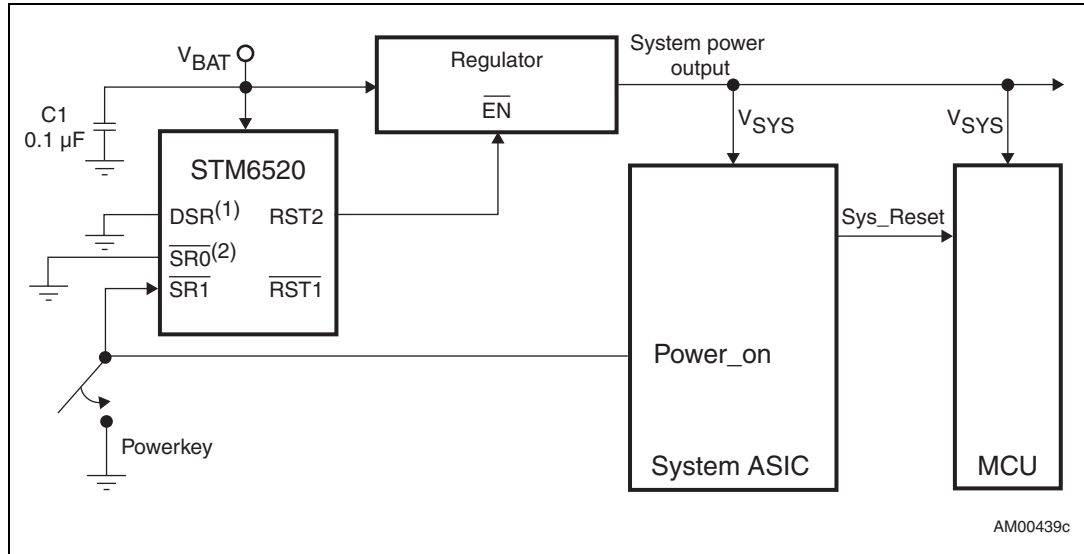

1. DSR pin (pin 5) must be tied to V_{CC} or V_{SS} .
2. When only one Smart Reset™ input is used, connect the unused one permanently to V_{SS} .

Figure 6. Timing waveforms

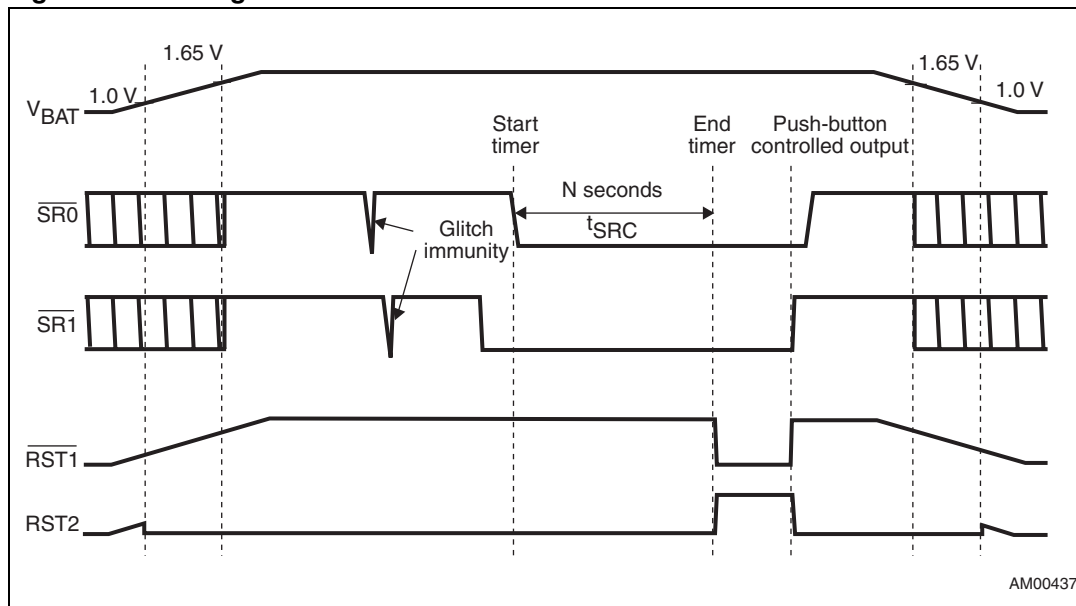
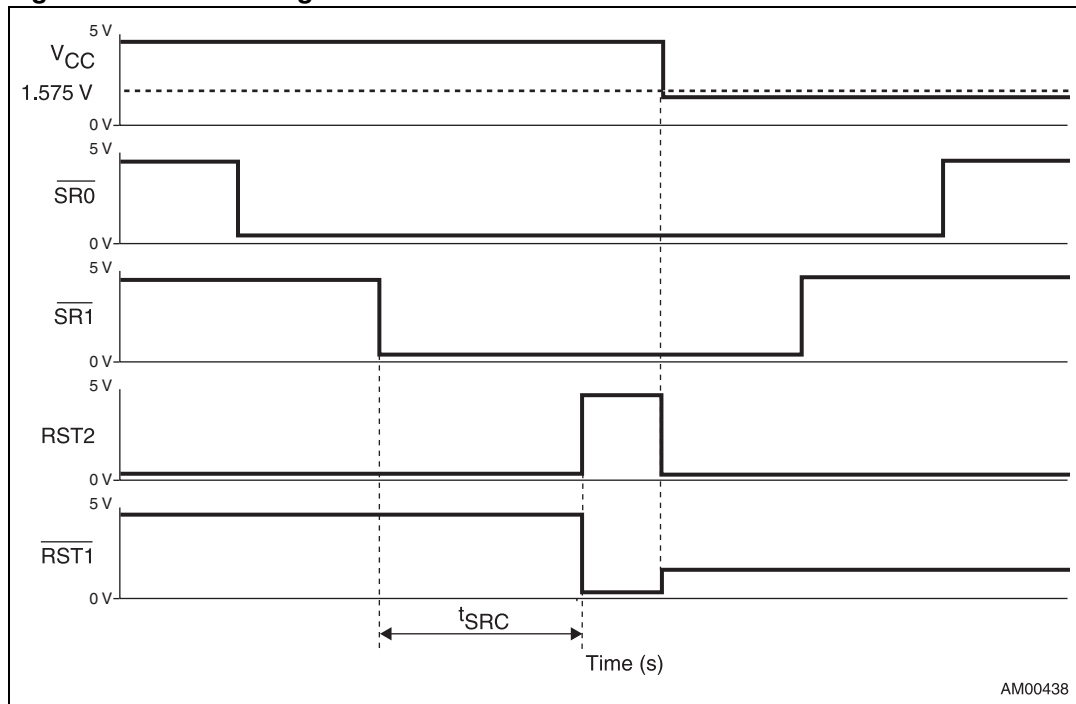

Figure 7. Undervoltage condition



Note: If undervoltage occurs (V_{CC} drops below 1.575 V typ.) while reset outputs are active, both outputs are released and go inactive.

5 Typical operating characteristics

Figure 8. Supply current (I_{CC}) vs. temperature

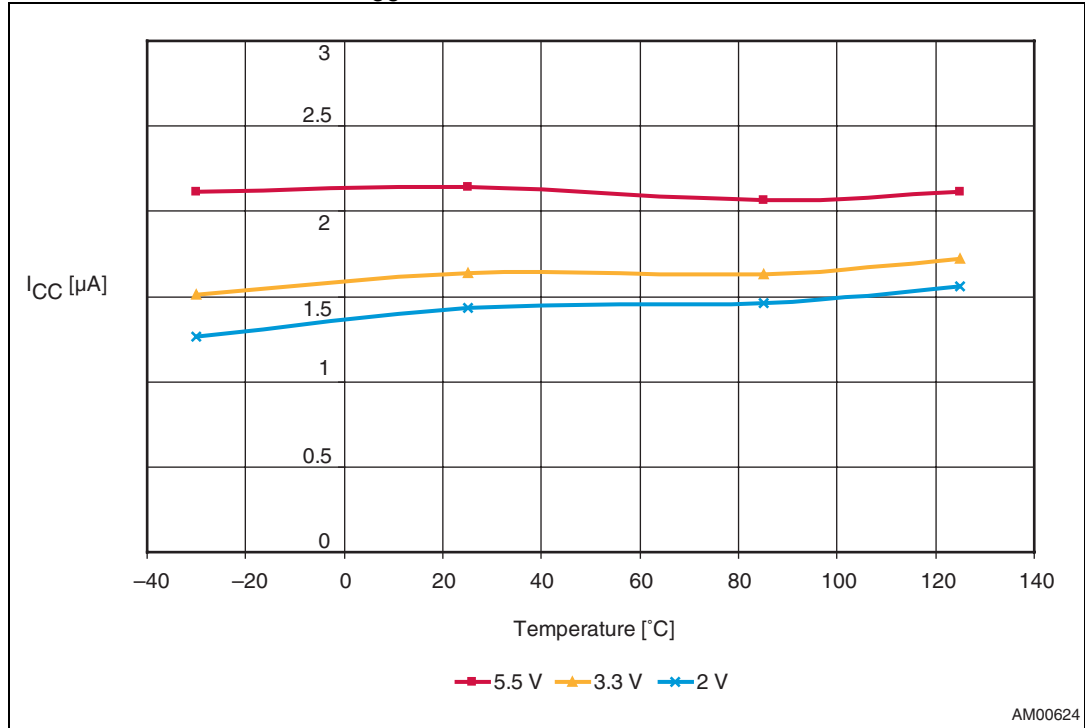
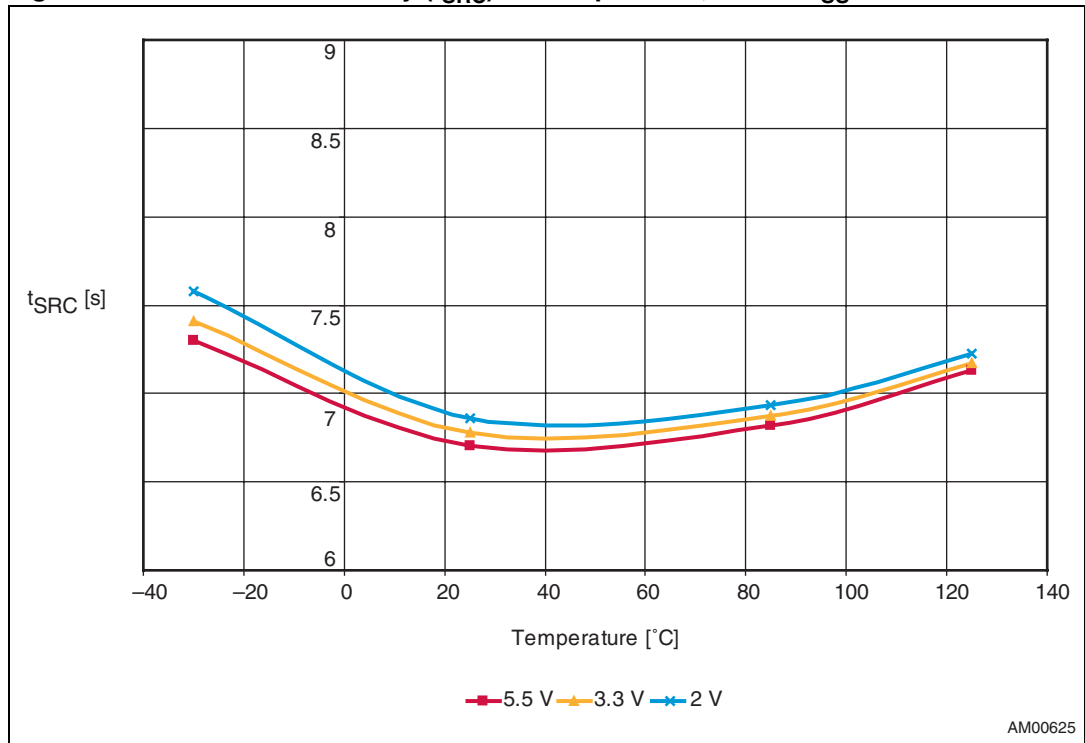

Figure 9. Smart Reset™ delay (t_{SRC}) vs. temperature, $DSR = V_{SS}$



6 Maximum rating

Stressing the device above the rating listed in the “Absolute maximum ratings” table may cause permanent damage to the device. These are stress ratings only and operation of the device at these or any other conditions above those indicated in the operating sections of this specification is not implied. Exposure to absolute maximum rating conditions for extended periods may affect device reliability. Refer also to the STMicroelectronics SURE Program and other relevant quality documents.

Table 2. Absolute maximum ratings

Symbol	Parameter	Value	Unit
T_{STG}	Storage temperature (V_{CC} off)	-55 to +150	°C
$T_{SLD}^{(1)}$	Lead solder temperature for 10 seconds	260	°C
θ_{JA}	Thermal resistance (junction to ambient)	TDFN8 149.0	°C/W
V_{IO}	Input or output voltage	-0.3 to 5.5 ⁽²⁾	V
V_{CC}	Supply voltage	-0.3 to 7	V
ESD			
V_{HBM}	Electrostatic discharge protection, human body model, all pins (JESD22-A114-B level 2)	2	kV
V_{RCDM}	Electrostatic discharge protection, charged device model, all pins	1	kV
V_{MM}	Electrostatic discharge protection, machine model, all pins (JESD22-A115-A level A)	200	V
	Latch-up (V_{CC} pin, reset input pins)	EIA/JESD78	

1. Reflow at peak temperature of 260 °C. The time above 255 °C must not exceed 30 seconds.
2. For RST2 -0.3 to V_{CC} +0.3 V only.

7 DC and AC parameters

This section summarizes the operating measurement conditions, and the DC and AC characteristics of the device. The parameters in the DC and AC characteristics table that follow, are derived from tests performed under the Measurement Conditions summarized in [Table 3: Operating and measurement conditions](#). Designers should check that the operating conditions in their circuit match the operating conditions when relying on the quoted parameters.

Table 3. Operating and measurement conditions

Parameter	Value	Unit
V _{CC} supply voltage	1.65 to 5.5	V
Ambient operating temperature (T _A)	-30 to +85	°C
Input rise and fall times	≤5	ns
Input pulse voltages	0.2 to 0.8 V _{CC}	V
Input and output timing ref. voltages	0.3 to 0.7 V _{CC}	V

Figure 10. AC testing input/output waveforms

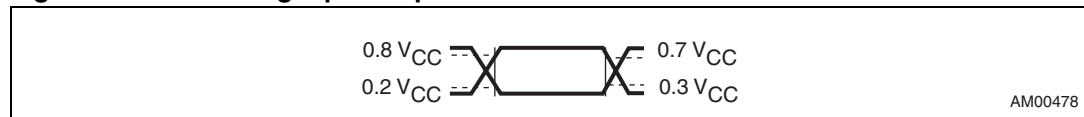

Table 4. DC and AC characteristics

Symbol	Parameter	Test conditions ⁽¹⁾	Min.	Typ. ⁽²⁾	Max.	Units
V _{CC}	Supply voltage range	Operating voltage ⁽³⁾	1.65		5.5	V
I _{CC}	Supply voltage	V _{CC} = 3.0 V, t _{SRC} counter is inactive		1.5	2.5	μA
		V _{CC} = 5.0 V, t _{SRC} counter is inactive		2.0	3.0	μA
		V _{CC} = 3.0 V, t _{SRC} counter is active		3.5		μA
		V _{CC} = 5.0 V, t _{SRC} counter is active		4.7		μA
V _{OL}	Reset output voltage low	V _{CC} ≥ 4.5 V, sinking 3.2 mA			0.3	V
		V _{CC} ≥ 3.3 V, sinking 2.5 mA			0.3	V
		V _{CC} ≥ 1.65 V, sinking 1 mA			0.3	V
V _{OH}	Reset output voltage high, RST2	V _{CC} ≥ 4.5 V, I _{SOURCE} = 0.8 mA	0.8 V _{CC}			V
		V _{CC} ≥ 2.7 V, I _{SOURCE} = 0.5 mA	0.8 V _{CC}			V
		V _{CC} ≥ 1.65 V, I _{SOURCE} = 0.25 mA	0.8 V _{CC}			V
I _{LO}	Output leakage current, $\overline{\text{RST1}}$	Open-drain, V _{RST1} = 5.5 V	-0.1		0.1	μA
Smart Reset™						
t _{SRC}	Smart Reset™ delay	DSR = V _{SS}	6	7.5	9	s
		DSR = V _{CC}	10	12.5	15	s
V _{IL}	$\overline{\text{SR0}}$, $\overline{\text{SR1}}$ input voltage low		V _{SS} - 0.3		0.3	V
V _{IH}	$\overline{\text{SR0}}$, $\overline{\text{SR1}}$ input voltage high		0.85		5.5	V
I _{LI}	Input leakage current ($\overline{\text{SR0}}$, $\overline{\text{SR1}}$, DSR pins)		-1		1	μA
	Input glitch immunity ⁽⁴⁾	Corresponds to the actual t _{SRC}		t _{SRC}		s

- Valid for ambient operating temperature: T_A = -30 to +85 °C; V_{CC} = 1.65 to 5.5 V (except where noted).
- Typical value is at 25 °C and V_{CC} = 3.3 V unless otherwise noted.
- Reset outputs are deasserted below 1.575 V typ. and remain deasserted down to V_{CC} = 1 V.
- Input glitch immunity is equal to t_{SRC} (when both SR inputs are low), otherwise infinite.

8 Package mechanical data

In order to meet environmental requirements, ST offers these devices in different grades of ECOPACK® packages, depending on their level of environmental compliance. ECOPACK® specifications, grade definitions and product status are available at: www.st.com. ECOPACK® is an ST trademark.

Figure 11. TDFN - 8-lead, 2 x 2 mm package outline

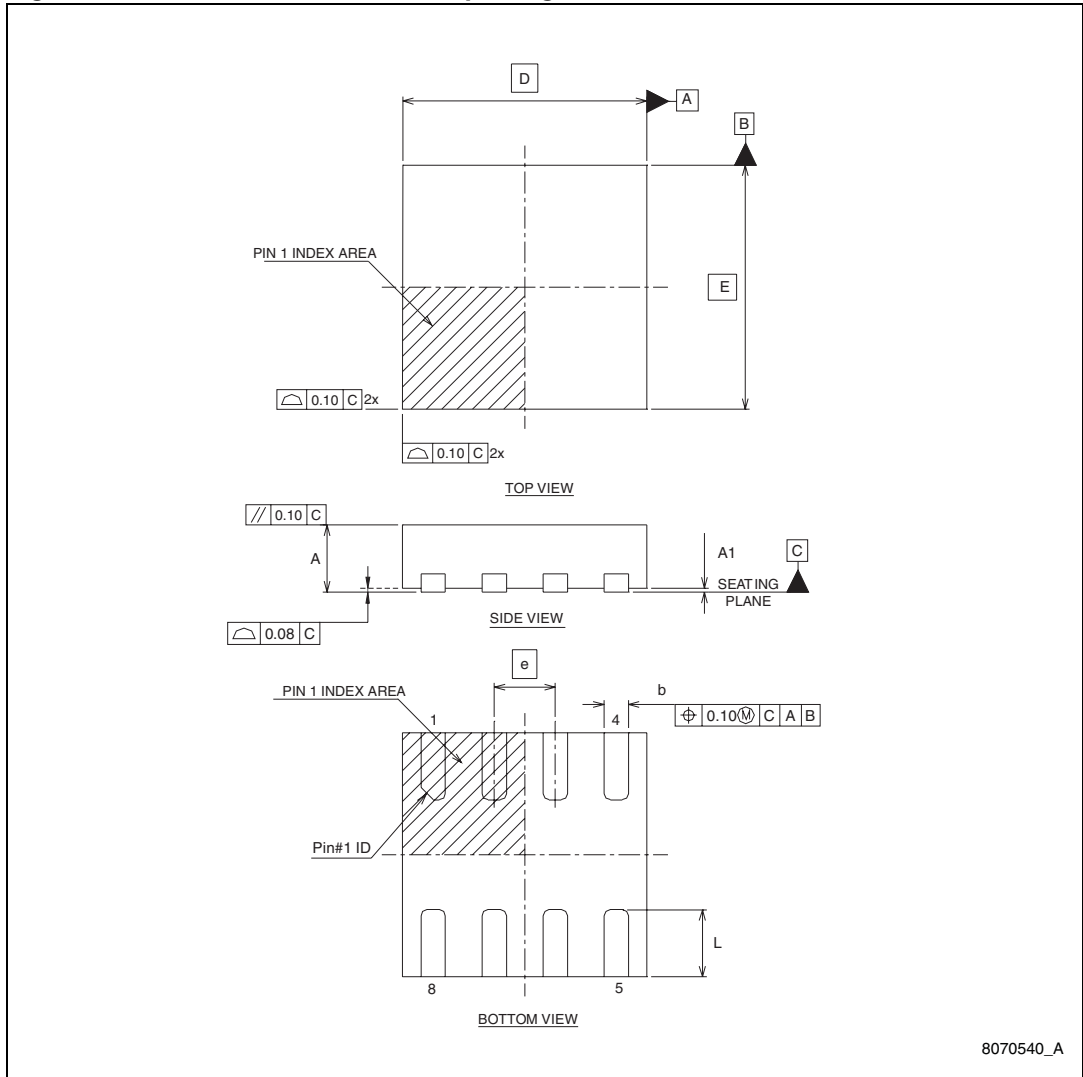

Table 5. TDFN – 8-lead 2 x 2 x 0.75 mm, 0.5 mm package mechanical data

Symbol	Dimension (mm)			Dimension (inches)		
	Min.	Nom.	Max.	Min.	Nom.	Max.
A	0.70	0.75	0.80	0.028	0.030	0.031
A1	0.00	0.02	0.05	0.000	0.001	0.002
b	0.15	0.20	0.25	0.006	0.008	0.010
D BSC	1.9	2.00	2.1	0.075	0.079	0.083
E BSC	1.9	2.00	2.1	0.075	0.079	0.083
e		0.50			0.020	
L	0.45	0.55	0.65	0.018	0.022	0.026

9 Package footprint

Figure 12. Landing pattern - TDFN – 8-lead 2 x 2 mm without thermal pad

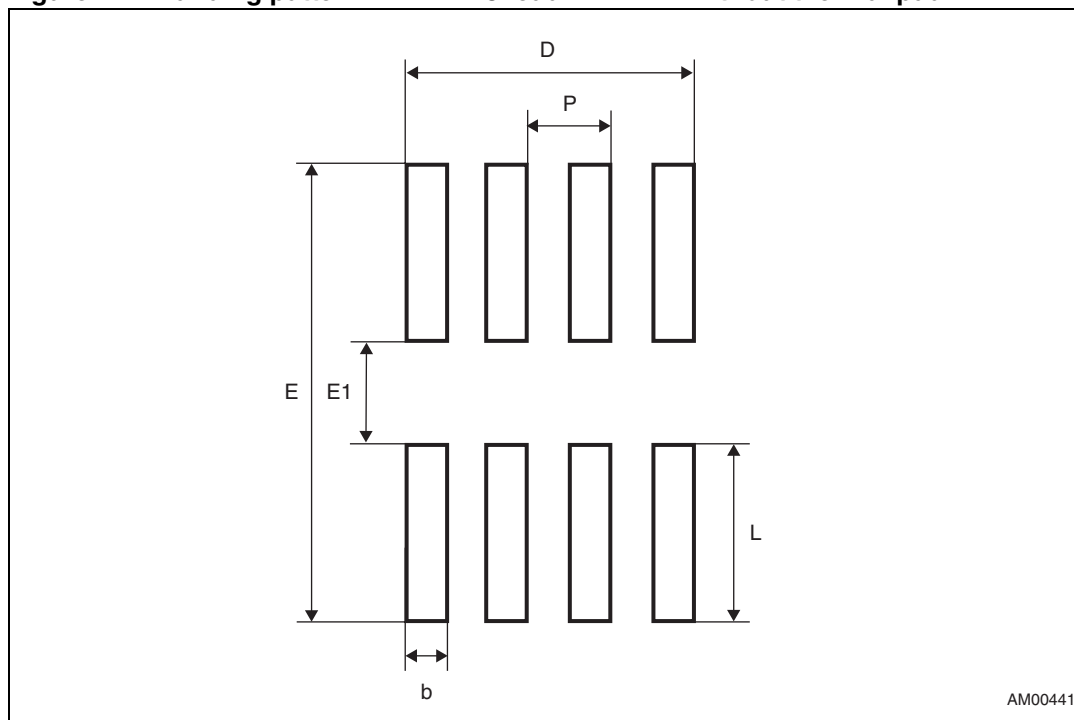

Table 6. Parameter for landing pattern - TDFN – 8-lead 2 x 2 mm package

Parameter	Description	Dimension (mm)		
		Min.	Nom.	Max.
L	Contact length	1.05	—	1.15
b	Contact width	0.25	—	0.30
E	Max. land pattern Y-direction	—	2.85	—
E1	Contact gap spacing	—	0.65	—
D	Max. land pattern X-direction	—	1.75	—
P	Contact pitch	—	0.5	—

10 Tape and reel information

Figure 13. Carrier tape

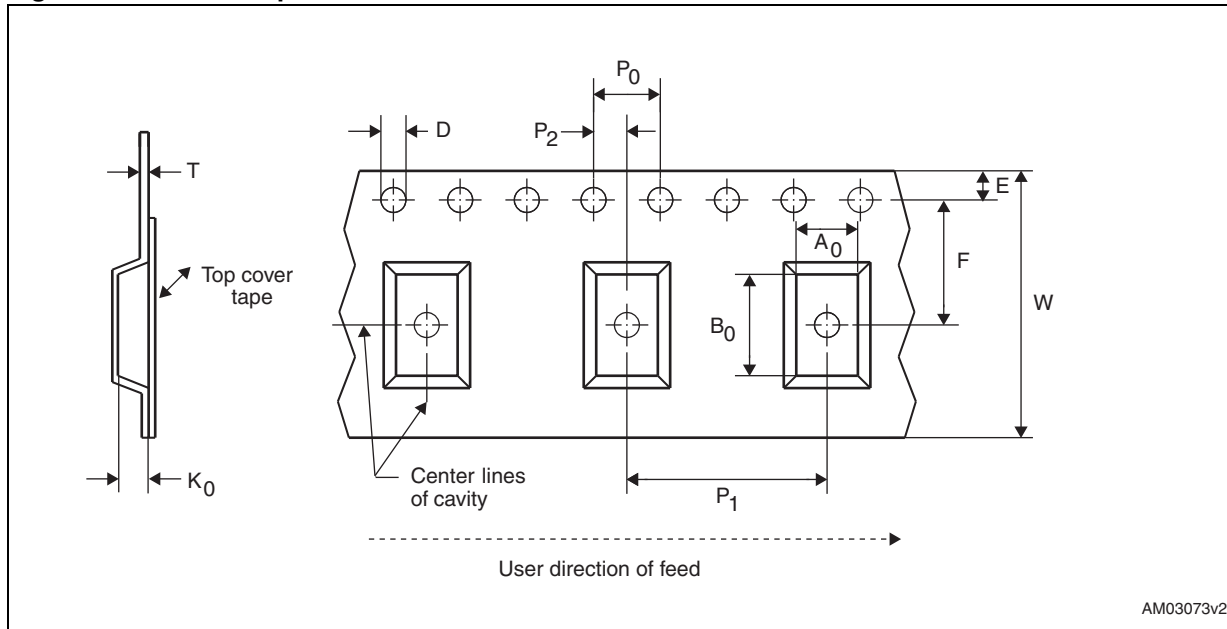

Table 7. Carrier tape dimensions

Package	W	D	E	P ₀	P ₂	F	A ₀	B ₀	K ₀	P ₁	T	Unit	Bulk qty.
TDFN8	8.00 +0.30 -0.10	1.50 +0.10/ -0.00	1.75 ±0.10	4.00 ±0.10	2.00 ±0.10	3.50 ±0.05	2.30 ±0.05	2.30 ±0.05	1.00 ±0.05	4.00 ±0.10	0.250 ±0.05	mm	3000

Figure 14. Reel dimensions

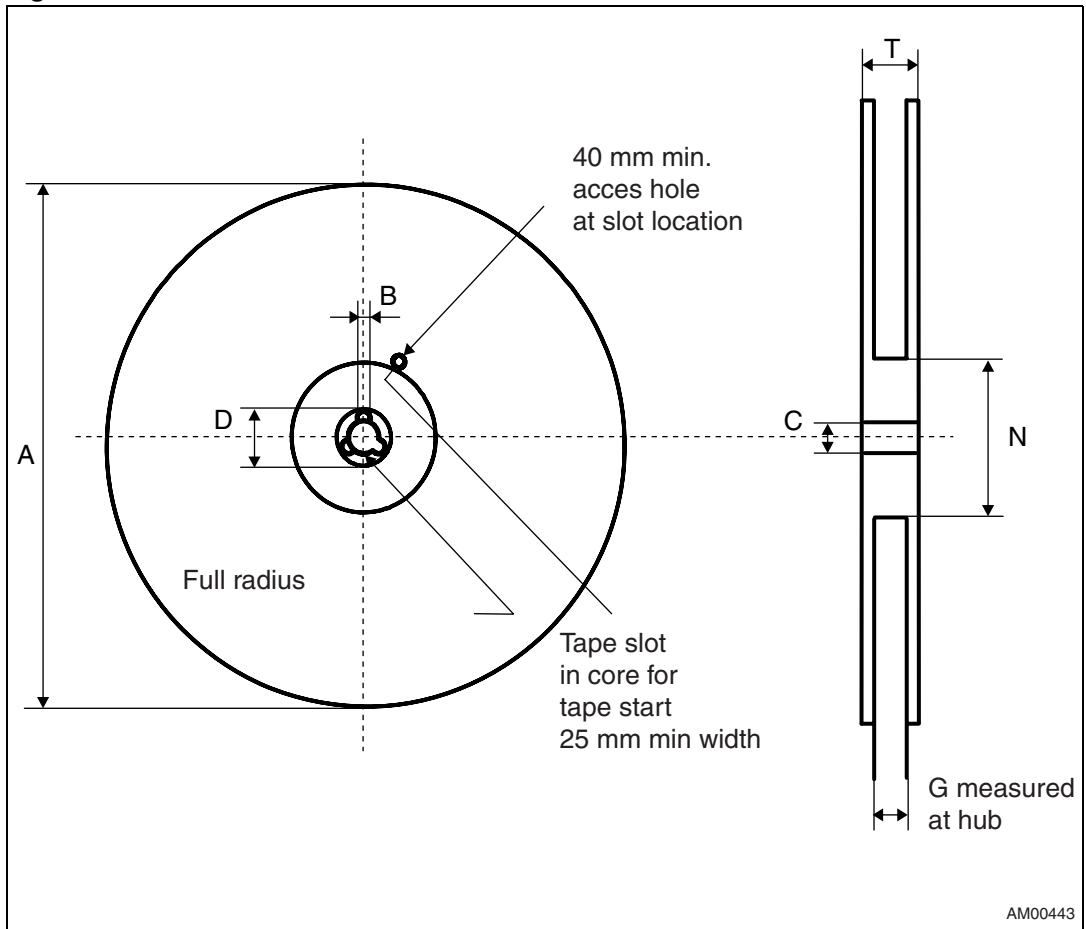

Table 8. Reel dimensions

Tape sizes	A max.	B min.	C	D min.	N min.	G	T max.
8 mm	180 (7 inches)	1.50	13.0 +/- 0.20	20.20	60	8.4 +2/-0	14.40

Figure 15. Tape trailer/leader

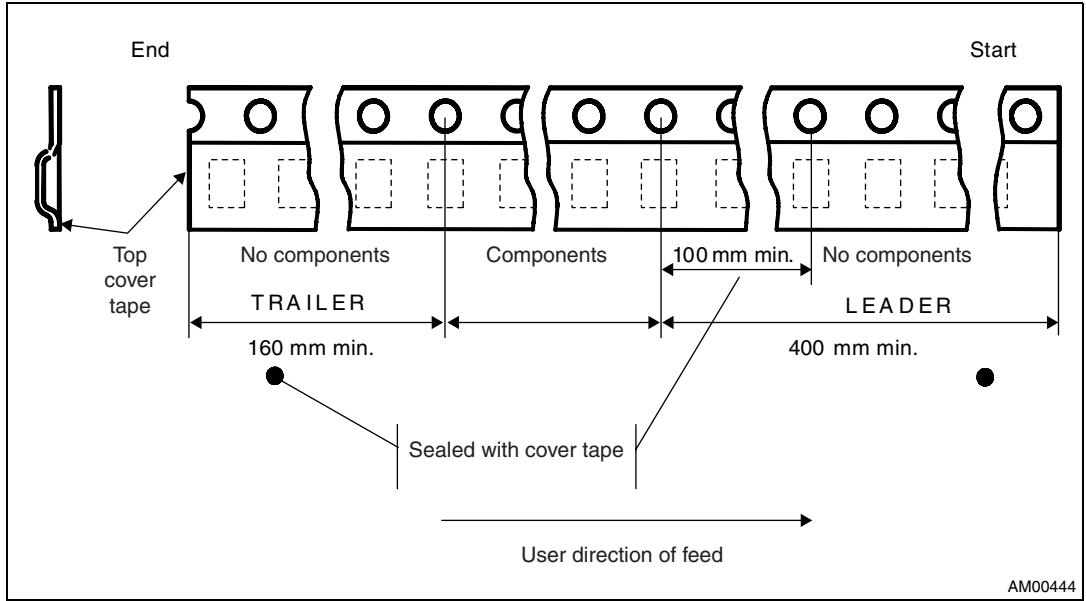
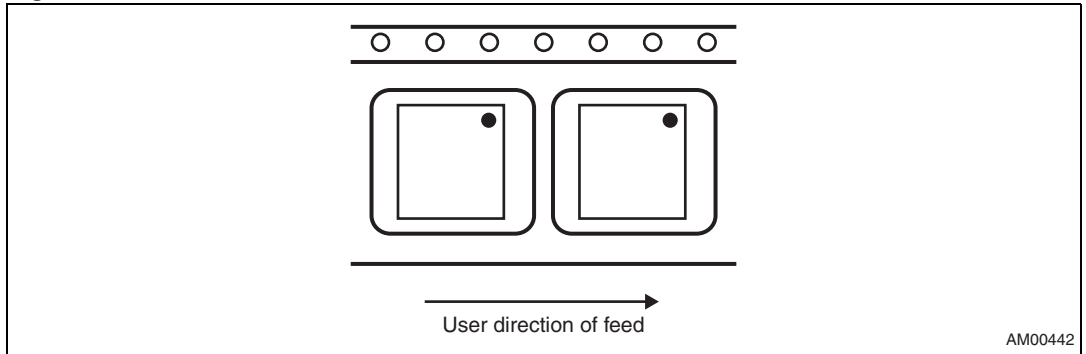

Figure 16. Pin 1 orientation



- Note: 1 Drawings are not to scale.
2 All dimensions are in mm, unless otherwise noted.

11 Ordering information

Table 9. Ordering information scheme

Example:	STM6520	A	Q	R	R	DG	9	F
Device type	STM6520							
Reset (V_{CC} monitoring threshold) voltage V_{RST}	A = no V_{CC} monitoring feature							
Smart Reset™ setup delay (t_{SRC})	Q = 7.5 or 12.5 s typ., user-selected (two-state); input comparator on SR0, SR1, no input pull-ups							
Outputs type	R = $\overline{RST1}$ active-low, open-drain, no pull-up; RST2 active-high, push-pull							
Reset pulse timeout period (t_{REC})	R = push-button controlled (no defined t_{REC} , no power-on reset)							
Package	DG = TDFN8 2 x 2 x 0.75 mm, 0.5 mm pitch							
Temperature range	9 = -30 °C to +85 °C							
Shipping method	F = ECOPACK® package, tape and reel							

For other options, voltage threshold values etc. or for more information on any aspect of this device, please contact the ST sales office nearest you.

12 Package marking information

Table 10. Package marking

Part number	Package	Topmark
STM6520AQRRDG9F	TDFN8 2 x 2 x 0.75 mm, 0.5 mm pitch	DRM
STM6520AQRRDG9F	TDFN8 2 x 2 x 0.75 mm, 0.5 mm pitch	ERM

Figure 17. Package marking area, top view

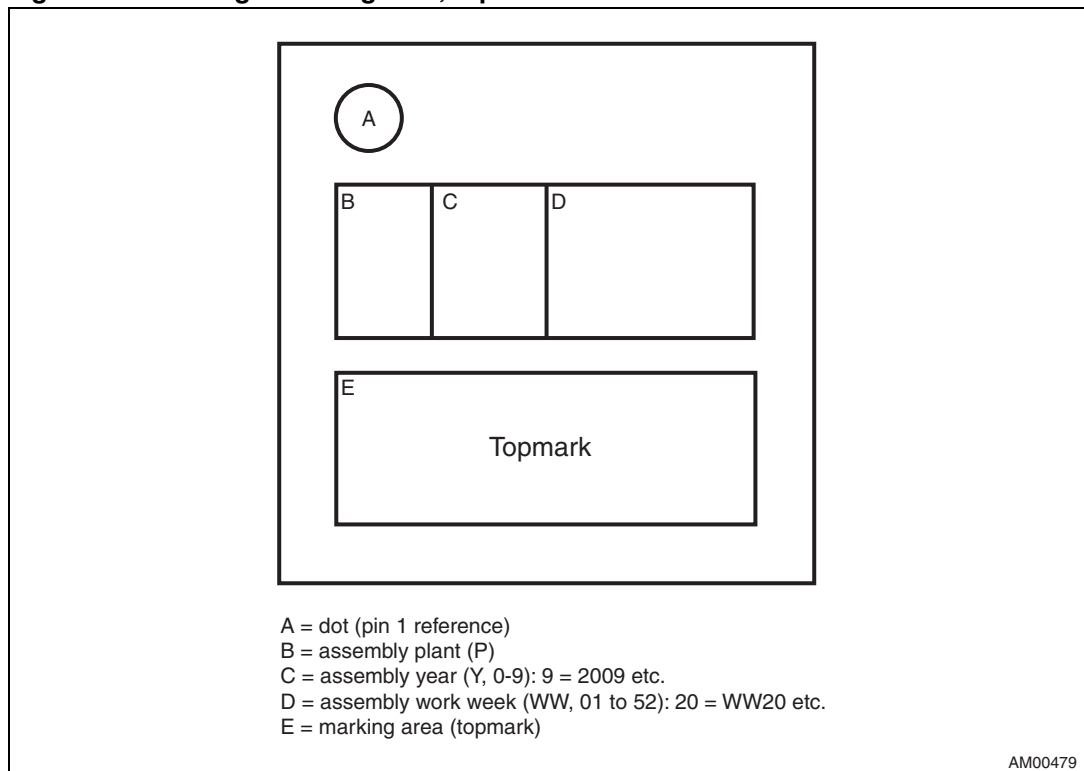

13 Revision history

Table 11. Document revision history

Date	Revision	Changes
08-Jul-2009	1	Initial release.
20-Oct-2009	2	Document reformatted, updated Section 1: Description , Table 1 , Figure 4 , Figure 5 , Table 4 , renamed Section 2: Device overview , added Section 5: Typical operating characteristics , updated supply voltage range in Table 4 .
20-Jan-2010	3	Updated Section 1: Description , Table 1 .
06-May-2010	4	Updated title, Features , Applications , Table 5 .
31-May-2010	5	Replaced “smart reset” by “Smart Reset™”, updated Applications , Section 1 , Section 3.1 , Section 3.5 , Figure 4 , Figure 5 , Table 2 , Table 4 , Table 6 and Table 10 .
06-Jan-2011	6	Updated I _{CC} - supply voltage in Table 4 .

Please Read Carefully:

Information in this document is provided solely in connection with ST products. STMicroelectronics NV and its subsidiaries ("ST") reserve the right to make changes, corrections, modifications or improvements, to this document, and the products and services described herein at any time, without notice.

All ST products are sold pursuant to ST's terms and conditions of sale.

Purchasers are solely responsible for the choice, selection and use of the ST products and services described herein, and ST assumes no liability whatsoever relating to the choice, selection or use of the ST products and services described herein.

No license, express or implied, by estoppel or otherwise, to any intellectual property rights is granted under this document. If any part of this document refers to any third party products or services it shall not be deemed a license grant by ST for the use of such third party products or services, or any intellectual property contained therein or considered as a warranty covering the use in any manner whatsoever of such third party products or services or any intellectual property contained therein.

UNLESS OTHERWISE SET FORTH IN ST'S TERMS AND CONDITIONS OF SALE ST DISCLAIMS ANY EXPRESS OR IMPLIED WARRANTY WITH RESPECT TO THE USE AND/OR SALE OF ST PRODUCTS INCLUDING WITHOUT LIMITATION IMPLIED WARRANTIES OF MERCHANTABILITY, FITNESS FOR A PARTICULAR PURPOSE (AND THEIR EQUIVALENTS UNDER THE LAWS OF ANY JURISDICTION), OR INFRINGEMENT OF ANY PATENT, COPYRIGHT OR OTHER INTELLECTUAL PROPERTY RIGHT.

UNLESS EXPRESSLY APPROVED IN WRITING BY AN AUTHORIZED ST REPRESENTATIVE, ST PRODUCTS ARE NOT RECOMMENDED, AUTHORIZED OR WARRANTED FOR USE IN MILITARY, AIR CRAFT, SPACE, LIFE SAVING, OR LIFE SUSTAINING APPLICATIONS, NOR IN PRODUCTS OR SYSTEMS WHERE FAILURE OR MALFUNCTION MAY RESULT IN PERSONAL INJURY, DEATH, OR SEVERE PROPERTY OR ENVIRONMENTAL DAMAGE. ST PRODUCTS WHICH ARE NOT SPECIFIED AS "AUTOMOTIVE GRADE" MAY ONLY BE USED IN AUTOMOTIVE APPLICATIONS AT USER'S OWN RISK.

Resale of ST products with provisions different from the statements and/or technical features set forth in this document shall immediately void any warranty granted by ST for the ST product or service described herein and shall not create or extend in any manner whatsoever, any liability of ST.

ST and the ST logo are trademarks or registered trademarks of ST in various countries.

Information in this document supersedes and replaces all information previously supplied.

The ST logo is a registered trademark of STMicroelectronics. All other names are the property of their respective owners.

© 2011 STMicroelectronics - All rights reserved

STMicroelectronics group of companies

Australia - Belgium - Brazil - Canada - China - Czech Republic - Finland - France - Germany - Hong Kong - India - Israel - Italy - Japan - Malaysia - Malta - Morocco - Philippines - Singapore - Spain - Sweden - Switzerland - United Kingdom - United States of America

www.st.com