



STBC08

800mA Standalone linear Li-Ion Battery charger with thermal regulation

Feature summary

- Programmable charge current up to 800mA
- No external MOSFET, sense resistors or blocking diode required
- Complete linear charger for single cell lithium-ion batteries
- Constant current / constant voltage operation with thermal regulation to maximize charge rate without risk of overheating
- Two charge status output pins
- Charges single cell li-ion batteries directly from USB port
- Preset 4.2V charge voltage with 1% accuracy
- Charge current monitor for gas gauging
- Automatic recharge
- Under-voltage lockout
- C/10 Charge termination
- 25µA supply current in shutdown mode
- Low battery voltage detect for precharge setting
- Soft-start feature limits inrush current
- DFN6 (3x3mm) package (for better power dissipation)

Applications

- Cellular telephones
- PDAs
- Bluetooth applications
- Battery-powered devices

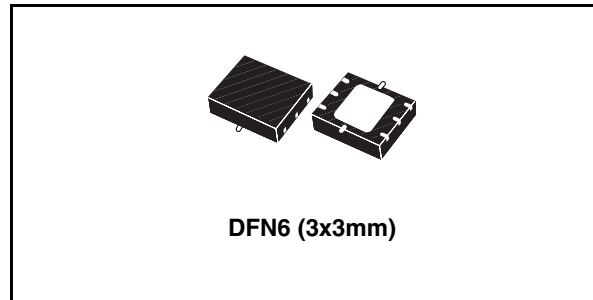

Description

The STBC08 is a constant current/constant voltage charger for single cell Li-Ion batteries. No external sense resistor or blocking diode is required.

The STBC08 is designed to work within USB power specifications. An internal block regulates the current when the junction temperature increases, in order to protect the device when it operates in high power or high ambient temperature conditions.

The charge voltage is fixed at 4.2V, and current limitation can be programmed using a single resistor connected between PROG pin and GND. The charge cycle is automatically terminated when the current flowing to the battery is 1/10 of the programmed value. If the external adaptor is removed, the STBC08 turns off and a 2µA current can flow from the battery to the device. The device can be put into Shutdown Mode, reducing the supply current to 25µA. The device also has a charge current monitor, under voltage lockout, automatic recharge. The charge termination and input voltage presence are indicated by two separate status pins.

Order code

Part number	Package	Packaging
STBC08PMR	QFN6 (3mm x 3mm)	4500 parts per reel

Contents

1	Block diagram	3
2	Pin configuration	4
3	Maximum ratings	5
4	Electrical characteristics	6
5	Typical performance characteristics	8
6	Application information	10
6.1	Charge cycle	10
6.2	V _{CC} Pin	10
6.3	Power ON pin	10
6.4	CHRG pin	10
6.5	PROG pin	11
6.6	Programming charge current	11
6.7	BAT pin	11
6.8	Charge termination	11
6.9	Automatic recharge	11
6.10	Soft start	12
6.11	Thermal regulation	12
6.12	Power dissipation	12
6.13	Stability considerations	12
7	Package mechanical data	13
8	Revision history	16

1 Block diagram

Figure 1. Block diagram

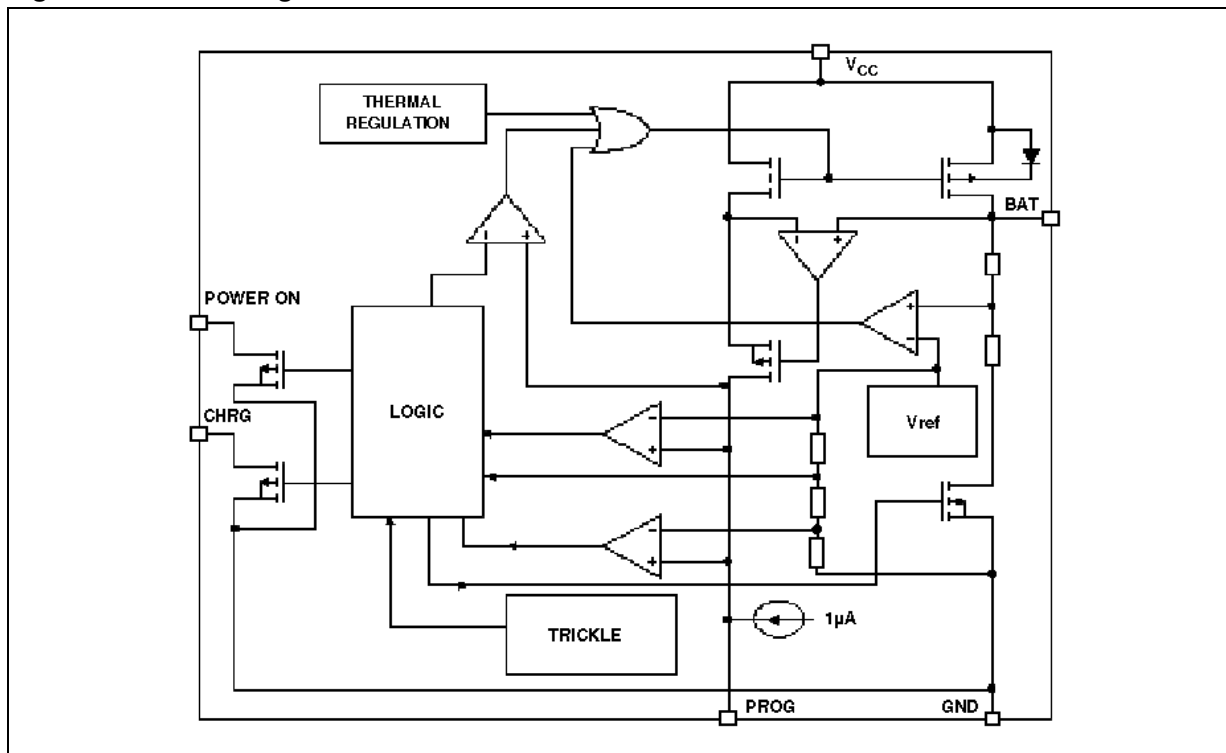

2 Pin configuration

Figure 2. Pin connections (top view)

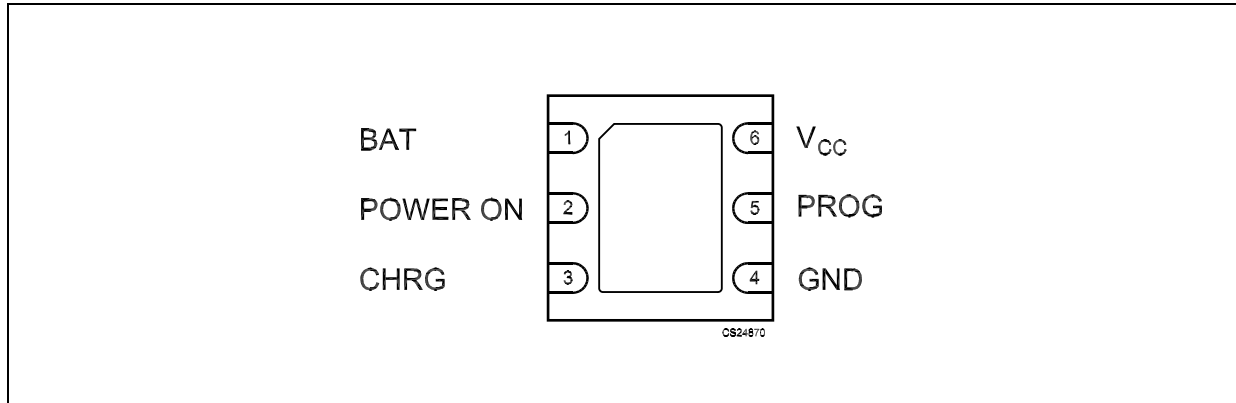
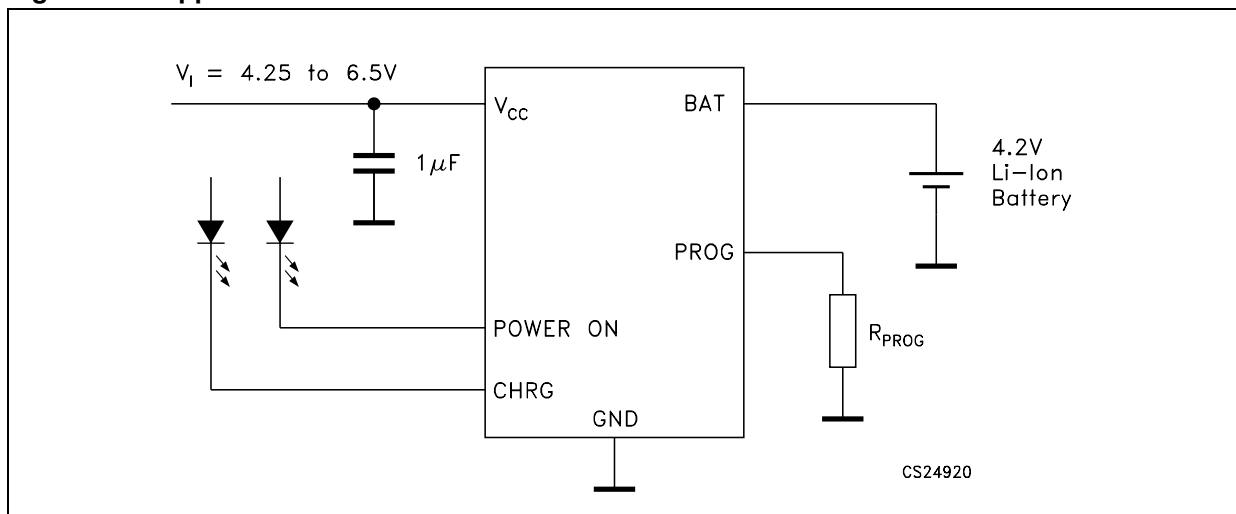

Table 1. Pin description

Pin N°	Symbol	Note
1	BAT	This pin provides an accurate 4.2V output voltage and the charge current to the battery. Only 2µA reverse current can flow in to the device when in Shutdown mode
2	POWER ON	Open Drain. When the STBC08 detects an undervoltage lockout condition or when the external adaptor provide an input voltage higher than 7.2V or less than battery voltage, POWER ON goes in high impedance state
3	CHRG	Open Drain. This pin goes in low impedance when the STBC08 is in precharge or charge mode
4	GND	Ground pin
5	PROG	Charge current program. Charge Current monitor and shutdown pin. The current limitation is programmed using a 1% tolerance R _{PROG} between PROG pin and GND
6	V _{CC}	Input supply voltage. The input range is from 4.25 to 6.5V. If V _{CC} < V _{BAT} + 30mV the device enters Shutdown mode and the sinked I _{BAT} is less than 2µA

Figure 3. Application circuit



3 Maximum ratings

Table 2. Absolute maximum ratings

Symbol	Parameter	Value	Unit
V_{CC}	Input supply voltage	From -0.3 to 10	V
V_{BAT}	BAT pin voltage	From -0.3 to $V_{CC}+0.3$	V
V_{PROG}	PROG pin voltage	From -0.3 to $V_{CC}+0.3$	V
V_{CHRG}	CHRG pin voltage	From -0.3 to 7	V
$V_{POWER-ON}$	POWER ON pin voltage	From -0.3 to 7	V
I_{BAT}	BAT pin current	800	mA
I_{PROG}	PROG pin current	800	μ A
	BAT short circuit duration	Continuous	
P_D	Power dissipation	Internally Limited	mW
T_J	Max junction temperature	125	$^{\circ}$ C
T_{STG}	Storage temperature range	-65 to 125	$^{\circ}$ C
T_{OP}	Operating junction temperature range	-40 to 85	$^{\circ}$ C

Table 3. Thermal Data

Symbol	Parameter	Value	Unit
R_{thJA}	Thermal Resistance Junction-Ambient	105.7	$^{\circ}$ C/W

4 Electrical characteristics

Table 4. Electrical characteristics

 ($V_{CC} = 5V$, $C_I = 1\mu F$, $T_J = -40$ to 85° unless otherwise specified) (*Note 2*).

Symbol	Parameter	Test	Min.	Typ.	Max.	Unit	
V_{CC}	Supply voltage		4.25		6.5	V	
I_{CC}	Supply current (<i>Note 1</i>)	Charge mode, $R_{PROG} = 10K\Omega$		150	500	μA	
		Standby mode (charge terminated)		150	300		
		Shutdown mode	R_{PROG} not connected		21		40
			$V_{CC} < V_{BAT}$		17		50
		$V_{CC} < V_{UV}$		17	40		
V_{BAT}	Termination output voltage	$V_{CC} = 4.3V$ to $6.5V$	4.158	4.2	4.242	V	
I_{BAT}	BAT pin current	Current mode $R_{PROG} = 10K\Omega$	90	100	110	mA	
		Current mode $R_{PROG} = 2K\Omega$	465	500	535	mA	
		Standby mode $V_{BAT} = 4.2V$	0	-2.5	-6	μA	
		Shutdown mode (R_{PROG} not connected), $T_J = 25^\circ C$		± 1	± 2	μA	
		Sleep mode, $V_{CC} = 0V$, $T_J = 25^\circ C$		± 1	± 2	μA	
I_{PRE}	Pre-charge current	$V_{BAT} < 2.8V$ $R_{PROG} = 2K\Omega$ $T_J = 25^\circ C$	20	45	70	mA	
V_{PRE}	Pre-charge threshold	$R_{PROG} = 10K\Omega$ V_{BAT} falling	2.8	2.9	3.0	V	
		Hysteresis $R_{PROG} = 10K\Omega$	70	100	130	mV	
V_{UV}	V_{CC} Undervoltage lockout	V_{CC} Low to High $R_{PROG} = 10K\Omega$	3.65	3.80	3.95	V	
		Hysteresis $R_{PROG} = 10K\Omega$	50	180	300	mV	
V_{MSD}	Manual shutdown threshold	PROG Pin Rising	1.15	1.21	1.30	V	
		PROG Pin Falling	0.85	0.95	1.05		
V_{ASD}	$V_{CC} - V_{BAT}$ Lockout threshold	V_{CC} Low to High $T_J = 25^\circ C$ $R_{PROG} = 10K\Omega$	50	85	120	mV	
		V_{CC} High to Low $T_J = 25^\circ C$ $R_{PROG} = 10K\Omega$	5	30	50		
I_{TERM}	C/10 Termination current threshold (I_{BAT}/I_{BATC10}) (<i>Note 3</i>)	$R_{PROG} = 10K\Omega$		0.1		mA/mA	
		$R_{PROG} = 2K\Omega$		0.1			
V_{PROG}	PROG pin voltage	Current Mode $R_{PROG} = 10K\Omega$	0.93	1.0	1.07	V	
V_{CHRG}	CHRG Pin pull-down voltage	$I_{CHRG} = 5mA$		0.35	0.6	V	
I_{POWER_ON}	POWER-ON pin leakage current	Pull-up			1	μA	
I_{POWER_ON}	POWER-ON pin pull-down voltage	$I_{POWER-ON} = 5mA$		0.35	0.6	V	

Table 4. Electrical characteristics(V_{CC} = 5V, C₁ = 1μF, T_J = -40 to 85° unless otherwise specified) (*Note 2*).

Symbol	Parameter	Test	Min.	Typ.	Max.	Unit
ΔV _{RECHRG}	Recharger battery threshold voltage	Battery Voltage T _J =25°C R _{PROG} = 10KΩ		200		mV
T _{LIM}	Junction temperature in constant temperature mode			120		°C
R _{ON}	Power Fet "ON" resistance (Between V _{CC} and BAT)			600		mΩ
t _{SS}	Soft-start time	I _{BAT} =0 to I _{BAT} =1000V/R _{PROG}		100		μs
T _{RECHARGE}	Recharge comparator filter time <i>Note 4</i>	V _{BAT} High to Low	0.75	2	4.5	ms
t _{TERM}	Termination comparator filter time <i>Note 4</i>	I _{BAT} Falling Below I _{CHG} /10	400	1000	2500	μs
I _{PROG}	PROG pin pull-up current			1		μA

- Note:*
- 1 Supply current includes PROG pin current but not any current delivered to the battery through the V_{BAT} pin.
 - 2 The STBC08 was tested using a battery simulator and an output capacitor value of 4.7μF
 - 3 I_{TERM} is expressed as a fraction of measured full charge current with indicated PROG resistor
 - 4 Guaranteed by design

5 Typical performance characteristics

Figure 4. I_{BAT} vs Supply voltage

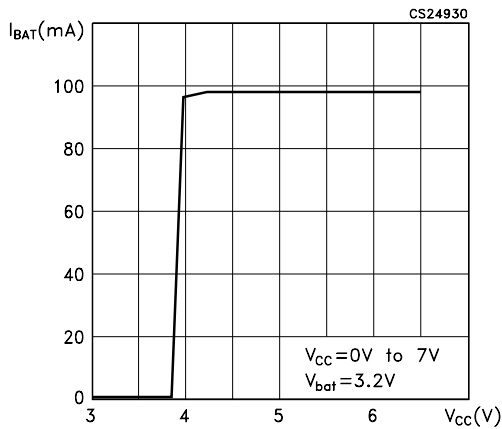

Figure 5. V_{BAT} vs V_{CC}

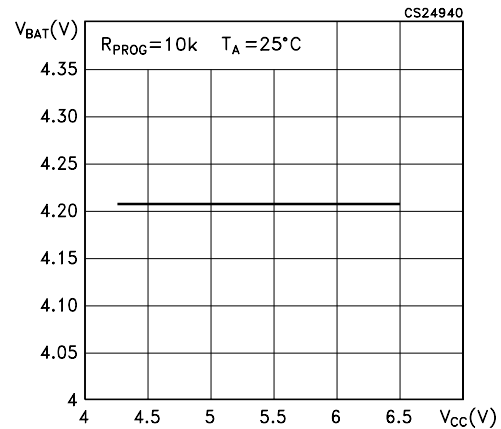

Figure 6. I_{BAT} vs temperature

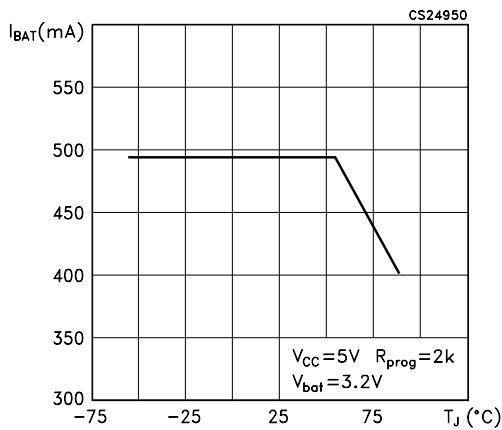

Figure 7. V_{PROG} vs temperature

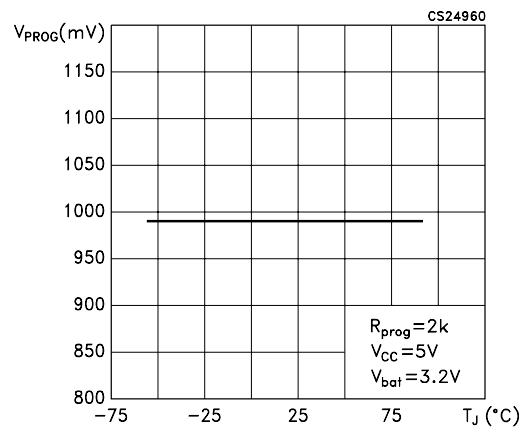

Figure 8. I_{BAT}/I_{PROG} vs temperature

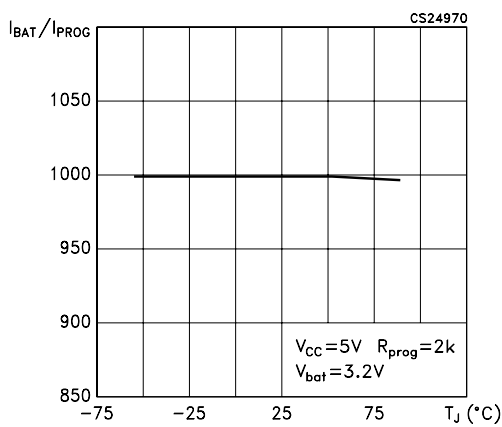

Figure 9. Recharge battery threshold voltage vs. temperature

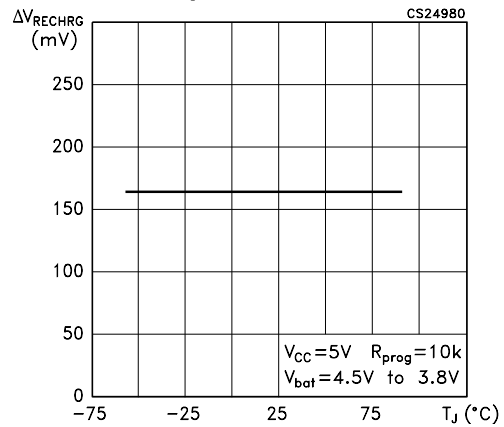

Figure 10. I_{BAT}/I_{PROG} vs V_{CC}

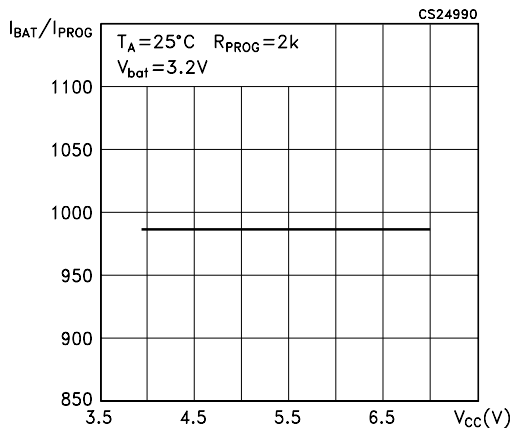

Figure 11. I_{BAT} vs V_{BAT}

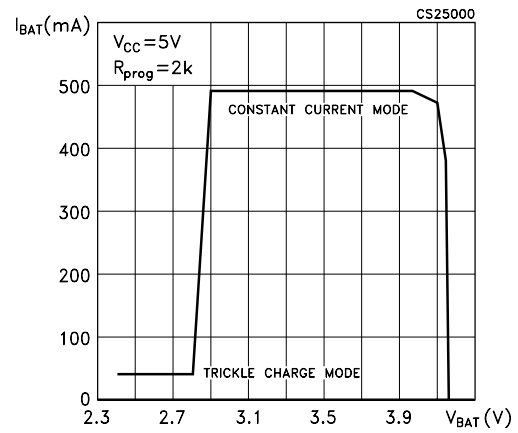

Figure 12. V_{CHRG} vs temperature (CHRG pin output low voltage)

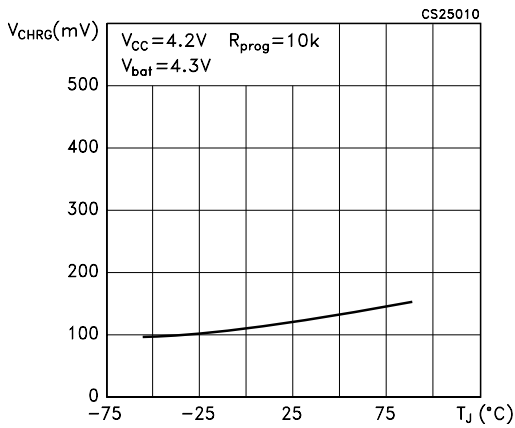

Figure 13. I_{BAT} vs V_{PROG}

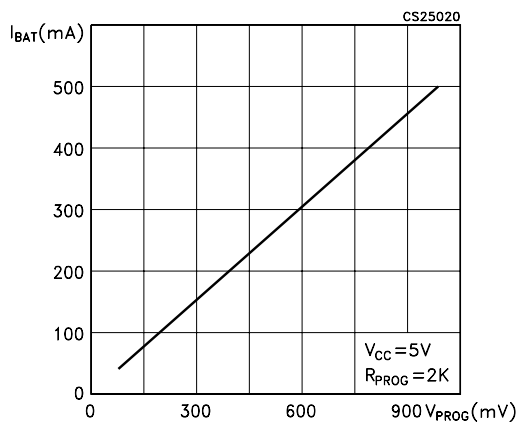
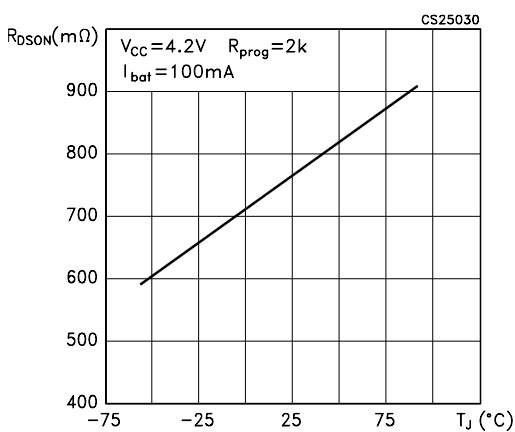

Figure 14. Power FET "ON" resistance



6 Application information

The STBC08 uses an internal P-Channel MOSFET to work in constant current and constant voltage method. It is able to provide up to 800mA with a final regulated output voltage of $4.2V \pm 1\%$ in full temperature range. No blocking diode and sensing resistor are required. It is also possible to use an USB port as power supply voltage.

6.1 Charge cycle

A charge cycle begins when the voltage at the V_{CC} pin rises above the UVLO threshold level, the R_{PROG} program resistor of 1% is connected between the PROG pin to GND pin and when a battery is connected to the charger output. If the battery voltage is below 2.9V, the charger enters Trickle Charge mode. In this condition, the device supplies 1/10 of the programmed charge current to bring the battery voltage up to safe level otherwise the life of a battery is reduced. If the BAT pin voltage is higher than 2.9V the charger enters in Constant Current Mode. When the BAT pin voltage is close to the final float voltage (4.2V) the device enters in Constant Voltage Mode and the charge current begins to decrease. The charge cycle is terminated when the current drops to 1/10 of the programmed value.

6.2 V_{CC} Pin

Input Supply Voltage. This pin is used to supply the device in the range from 4.25V to 6.5V voltage. A bypass capacitor of $1\mu F$ is recommended for use. When V_{CC} value drops of 30mV of the BAT pin voltage, the device enters in Shutdown Mode, dropping I_{BAT} to less than $2\mu A$.

6.3 Power ON pin

The POWER ON pin is an open drain flag that indicates V_{CC} presence, $V_{UVLO} < V_{CC} < 7.2V$ and $V_{CC} > V_{BAT}$. While in high impedance indicates that $V_{CC} < V_{UVLO}$, $V_{CC} > 7.2V$ or $V_{CC} < V_{BAT}$. In high impedance status the V_{CC} is insufficient to start the charge cycle.

6.4 CHRГ pin

The CHRГ pin is an open drain flag, it indicates the status of the charge. When the pin is in low state, the device is charging the battery. If the pin is in high impedance state the charge is terminated.

Table 5. CHRГ

		CHRГ	
		LOW	HIGH
Power-ON	LOW	00	01
	HIGH	-	11

Table 5 describes Flag Status values for the CHRГ pin.

- 00 is Precharge Mode (Trickle charge mode) or Charge Mode. V_{CC} is higher than V_{UVLO} and R_{PROG} is connected to the PROG pin.
- 01 is STANBY MODE (charge completed) or SHUTDOWN MODE (R_{PROG} not connected).
- 11 supply is not sufficient.

6.5 PROG pin

Charge Current Program, Charge Current Monitor and Shutdown Pin. The charge current is programmed by connecting a 1% resistor, R_{PROG} , to ground. When the device is charging in constant current, the value of voltage on this pin is 1.0V. In other conditions, the voltage on this pin can be used to measure the charge current using the following formula:

$$I_{BAT} = (V_{PROG}/R_{PROG}) * 1000$$

The PROG pin is used to shut down the device, disconnecting the program resistor from ground a $1\mu A$ current flows to pull the PROG pin high. If the value of this Pin is 1.21V (shutdown threshold voltage), the device enters Shutdown mode and the input supply current drops to $25\mu A$. Driving this pin to voltage beyond 2.4V a current of $35\mu A$ flows into the device from PROG pin.

6.6 Programming charge current

The R_{PROG} resistor is used to set the charge current value. The battery charge current is 1000 times the Prog pin current value. The program resistor and the charge current are calculated using the following formula:

$$R_{PROG} = 1000 * V_{PROG} / I_{BAT}$$

The charge current out of the BAT pin can be monitored through the PROG pin voltage using the following equation:

$$I_{BAT} = (V_{PROG}/R_{PROG}) * 1000$$

6.7 BAT pin

Charge Current Output pin. It provides charge current to the battery and regulates the final float voltage to 4.2V. An internal precision resistor is used as a feedback loop to compare the V_O with the reference.

6.8 Charge termination

A charge cycle is terminated when the final float voltage is reached consequently the charge current falls to 1/10th of the programmed value. The charge is over when the PROG pin voltage falls below 100mV for longer time than t_{TERM} (~1ms). The charge current is latched off, the device enters in standby mode and the input supply current drops to $200\mu A$.

6.9 Automatic recharge

The device restarts the charge cycle when the battery voltage falls below 4.05V to maintain the battery capacity value higher than 80%. During the recharge time, the CHRG pin goes low state.

6.10 Soft start

When a charge cycle starts, a internal soft start circuit minimizes the inrush current. At starting phase, the charge current ramps from zero to the full scale in a 100 μ s period time.

6.11 Thermal regulation

An internal thermal feedback loop reduces the output current if the die temperature attempts to rise above a present value of approximately 120°C. This feature protects the device from excessive temperature and allows the user to push the limits of the power handling capability of a given circuit board without risk of damaging the device.

6.12 Power dissipation

It is very important to use a good thermal PC board layout to maximize the available output current. The thermal path for the heat generated by the IC is from the die to the copper lead frame through the package leads and exposed pad to the PC board copper. The PC board copper is the heat sink. The footprint copper pads should be as wide as possible and expand out to larger copper areas to spread and dissipate the heat to the surrounding ambient. Feed through vias to inner or backside copper layers are also useful in improving the overall thermal performance of the device. Other heat sources on the board, not related to the device, must also be considered when designing a PC board layout because they will affect overall temperature rise and the maximum output current.

6.13 Stability considerations

The STBC08 contains two control loops: constant voltage and constant current. The constant-voltage loop is stable without any compensation when a battery is connected with low impedance leads. Excessive lead length, however, may add enough series inductance to require a bypass capacitor of at least 1 μ F from BAT to GND. Furthermore, a 4.7 μ F capacitor with a 0.2 Ω to 1 Ω series resistor from BAT to GND is required to keep ripple voltage low when the battery is disconnected.

7 Package mechanical data

In order to meet environmental requirements, ST offers these devices in ECOPACK® packages. These packages have a Lead-free second level interconnect. The category of second Level Interconnect is marked on the package and on the inner box label, in compliance with JEDEC Standard JESD97. The maximum ratings related to soldering conditions are also marked on the inner box label. ECOPACK is an ST trademark. ECOPACK specifications are available at: www.st.com.

Tape & Reel QFNxx/DFNxx (3x3) MECHANICAL DATA

DIM.	mm.			inch		
	MIN.	TYP	MAX.	MIN.	TYP.	MAX.
A			330			12.992
C	12.8		13.2	0.504		0.519
D	20.2			0.795		
N	60			2.362		
T			18.4			0.724
Ao		3.3			0.130	
Bo		3.3			0.130	
Ko		1.1			0.043	
Po		4			0.157	
P		8			0.315	

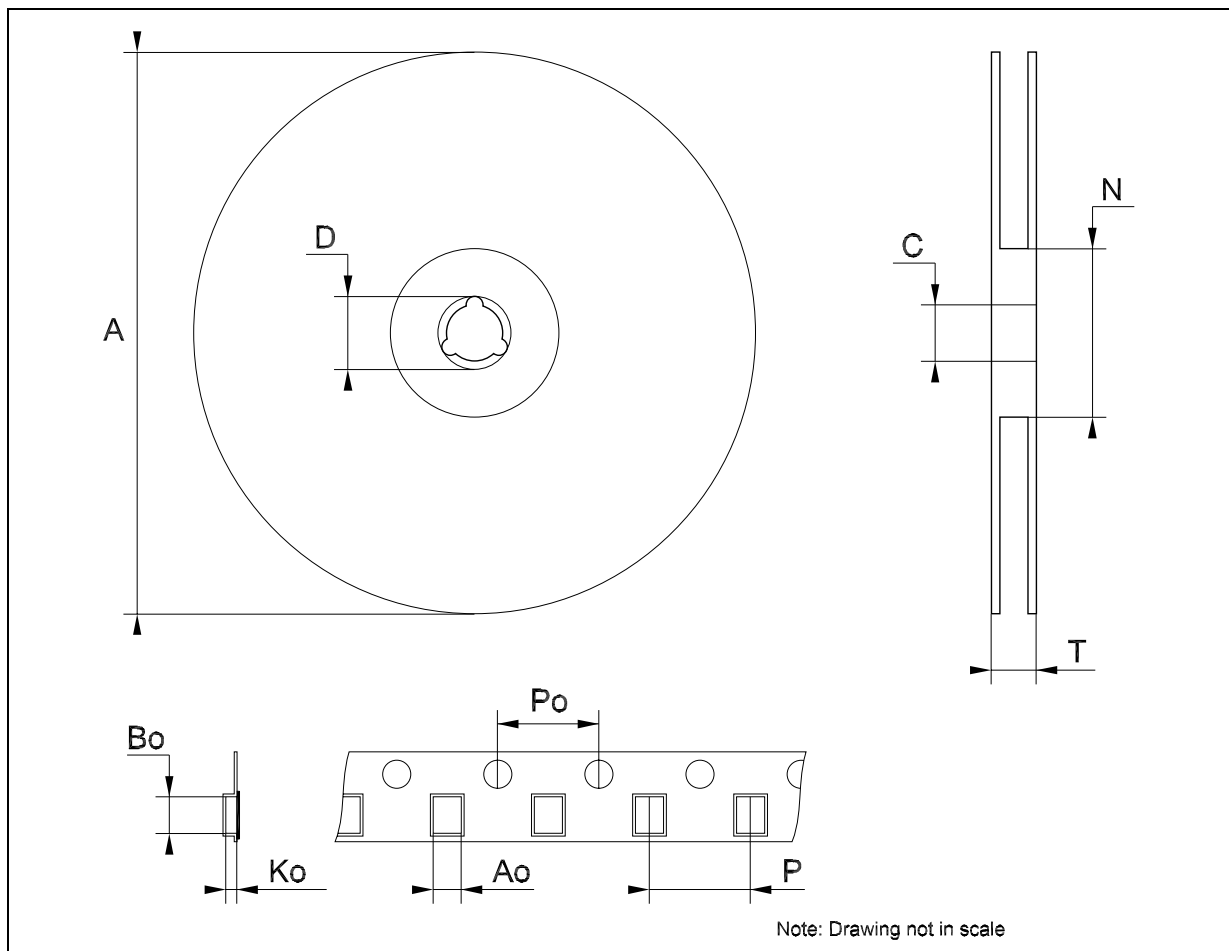

8 Revision history

Table 6. Revision history

Date	Revision	Changes
04-Sep-2006	1	Initial release.

Please Read Carefully:

Information in this document is provided solely in connection with ST products. STMicroelectronics NV and its subsidiaries ("ST") reserve the right to make changes, corrections, modifications or improvements, to this document, and the products and services described herein at any time, without notice.

All ST products are sold pursuant to ST's terms and conditions of sale.

Purchasers are solely responsible for the choice, selection and use of the ST products and services described herein, and ST assumes no liability whatsoever relating to the choice, selection or use of the ST products and services described herein.

No license, express or implied, by estoppel or otherwise, to any intellectual property rights is granted under this document. If any part of this document refers to any third party products or services it shall not be deemed a license grant by ST for the use of such third party products or services, or any intellectual property contained therein or considered as a warranty covering the use in any manner whatsoever of such third party products or services or any intellectual property contained therein.

UNLESS OTHERWISE SET FORTH IN ST'S TERMS AND CONDITIONS OF SALE ST DISCLAIMS ANY EXPRESS OR IMPLIED WARRANTY WITH RESPECT TO THE USE AND/OR SALE OF ST PRODUCTS INCLUDING WITHOUT LIMITATION IMPLIED WARRANTIES OF MERCHANTABILITY, FITNESS FOR A PARTICULAR PURPOSE (AND THEIR EQUIVALENTS UNDER THE LAWS OF ANY JURISDICTION), OR INFRINGEMENT OF ANY PATENT, COPYRIGHT OR OTHER INTELLECTUAL PROPERTY RIGHT.

UNLESS EXPRESSLY APPROVED IN WRITING BY AN AUTHORIZED ST REPRESENTATIVE, ST PRODUCTS ARE NOT RECOMMENDED, AUTHORIZED OR WARRANTED FOR USE IN MILITARY, AIR CRAFT, SPACE, LIFE SAVING, OR LIFE SUSTAINING APPLICATIONS, NOR IN PRODUCTS OR SYSTEMS WHERE FAILURE OR MALFUNCTION MAY RESULT IN PERSONAL INJURY, DEATH, OR SEVERE PROPERTY OR ENVIRONMENTAL DAMAGE. ST PRODUCTS WHICH ARE NOT SPECIFIED AS "AUTOMOTIVE GRADE" MAY ONLY BE USED IN AUTOMOTIVE APPLICATIONS AT USER'S OWN RISK.

Resale of ST products with provisions different from the statements and/or technical features set forth in this document shall immediately void any warranty granted by ST for the ST product or service described herein and shall not create or extend in any manner whatsoever, any liability of ST.

ST and the ST logo are trademarks or registered trademarks of ST in various countries.

Information in this document supersedes and replaces all information previously supplied.

The ST logo is a registered trademark of STMicroelectronics. All other names are the property of their respective owners.

© 2006 STMicroelectronics - All rights reserved

STMicroelectronics group of companies

Australia - Belgium - Brazil - Canada - China - Czech Republic - Finland - France - Germany - Hong Kong - India - Israel - Italy - Japan - Malaysia - Malta - Morocco - Singapore - Spain - Sweden - Switzerland - United Kingdom - United States of America

www.st.com