

#### PART NUMBER EXAMPLE

Ex.

914-250/104 K 10

1. Type \_\_\_\_\_
2. Rated voltage \_\_\_\_\_
3. Rated capacitance ( $\mu\text{F}$ ) \_\_\_\_\_
4. Tolerance \_\_\_\_\_
5. Lead spacing \_\_\_\_\_
6. Packaging code \_\_\_\_\_
7. Lead style code \_\_\_\_\_
8. Computer code (#) \_\_\_\_\_
9. Size in mm \_\_\_\_\_

#### MORE EXAMPLES

If formed to 5mm L/S: 914-250/104K10B1/5.

If cut & formed to 5mm L/S: 914-250/104K10B5/5.

If cut & formed to 5mm L/S & 3mm L/L: 914-250/104K10B1/5#1.  
 (#1 = one deviation from std ex.: L/L)

#### DESCRIPTION

Describes the construction and the dielectric type.

Rated voltage (3 digits). Ex. 050 = 050V, 250 = 250V, 1K0 = 1000V, 1K5 = 1500V

Rated capacitance (3 digits). The first two digits represent significant figures and the last digit is the number of zeros to follow. Ex. 102 = 1000pF = .001 $\mu\text{F}$ , 472 = 4700pF = .0047 $\mu\text{F}$ , 103 = 100000pF = .01 $\mu\text{F}$ , 104 = 100000pF = .1 $\mu\text{F}$ .

Tolerance (1 digit):

C	D	F	G	H	I	J	K	M	N	P	V	Z
$\pm$ 0.25pF	$\pm$ 0.5%	$\pm$ 1.0%	$\pm$ 2.0%	$\pm$ 2.5%	$\pm$ 3.0%	$\pm$ 5.0%	$\pm$ 10%	$\pm$ 20%	$\pm$ 30%	$+\infty$ , -0	+20, -10	+80, -20

Lead spacing (in mm) showing significant digits without decimals.

Packaging code: TR = Tape and Reel; TA = Tape and Ammo; B = Bulk.

Lead style code. Note: Previous character must be a letter, hence, for bulk packaging use the letter B.

Long Leads				Cut Leads			
Straight Long Leads/Non-Forming	Inside Forming Without Cut	Outside Forming Without Cut	Kink Without Cut	Non-Forming With Cut	Inside Forming With Cut	Outside Forming With Cut	Kink With Cut
0	1	2	3	4	5	6	7

Straight lead length portion = 25mm minimum.

Straight lead length portion = 5mm  $\pm$  1mm.

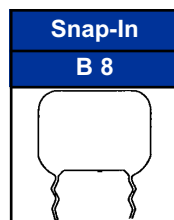
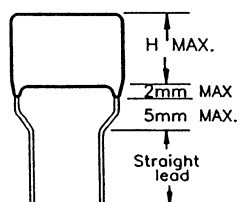

Due to the continued improvement of capacitor manufacturing technology, other sizes and values, not described in this catalog, may now be available. Please contact Factory or Area Representative for latest data.

EIA Code	( $\mu$ F) MicroFarad	(pF) PicoFarad	(nF) NanoFarad
1R5		1.5	0.0015
2R2		2.2	0.0022
3R3		3.3	0.0033
4R7		4.7	0.0047
6R8		6.8	0.0068
100		10	0.01
150		15	0.015
220		22	0.022
250		25	0.025
330		33	0.033
390		39	0.039
470		47	0.047
500		50	0.05
560		56	0.056
680		68	0.068
750		75	0.075
820		82	0.082
101	0.00010	100	0.1
121	0.00012	120	0.12
151	0.00015	150	0.15
181	0.00018	180	0.18
201	0.00020	200	0.2
221	0.00022	220	0.22
251	0.00025	250	0.25
271	0.00027	270	0.27
301	0.00030	300	0.3
331	0.00033	330	0.33
391	0.00039	390	0.39
401	0.00040	400	0.4
471	0.00047	470	0.47
501	0.00050	500	0.5
561	0.00056	560	0.56
681	0.00068	680	0.68
751	0.00075	750	0.75
821	0.00082	820	0.82
102	0.001	1000	1.0
122	0.0012	1200	1.2
152	0.0015	1500	1.5
202	0.002	2000	2.0
222	0.0022	2200	2.2
252	0.0025	2500	2.5
272	0.0027	2700	2.7
302	0.003	3000	3.0
332	0.0033	3300	3.3
392	0.0039	3900	3.9
472	0.0047	4700	4.7
562	0.0056	5600	5.6
682	0.0068	6800	6.8
822	0.0082	8200	8.2
103	0.01	10000	10.0
123	0.012	12000	12.0
153	0.015	15000	15.0
183	0.018	18000	18.0
223	0.022	22000	22.0

EIA Code	( $\mu$ F) MicroFarad	(pF) PicoFarad	(nF) NanoFarad
273	0.027	27000	27.0
333	0.033	33000	33.0
393	0.039	39000	39.0
473	0.047	47000	47.0
563	0.056	56000	56.0
683	0.068	68000	68.0
823	0.082	82000	82.0
104	0.1		100.0
124	0.12		120.0
154	0.15		150.0
184	0.18		180.0
224	0.22		220.0
274	0.27		270.0
334	0.33		330.0
394	0.39		390.0
474	0.47		470.0
564	0.56		560.0
684	0.68		680.0
824	0.82		820.0
105	1.0		1000.0
125	1.2		
155	1.5		
205	2.0		
305	3.0		
405	4.0		
505	5.0		
106	10.0		
107	100		
108	1000		

Code	$\mu$ F	pF
125	1.2	1200000
1754	1.75	1750000
1755	17.5	17500000
1756	175	175000000
472	0.0047	4700
7871	0.00787	7870

**Capacitance**, expressed in picoFarad.  
The first digits are significant figures.  
The last is the number of zeros.

**NOTE:** If four digits are present, the first three digits are significant figures, and the fourth is the number of zeros, etc.

TI Capacitors are produced on automatic machinery using computer control and SPC techniques. All capacitors are 100% tested for capacitance, dissipation factor and dielectric strength.

Unless otherwise specified, we apply MIL-STD-105, level II AQL 0.01% (reject on one) sampling plan for major electrical characteristics and 0.65% for minor characteristics before shipments. Custom sampling plans available upon request.

- **CAPACITANCE:** Measured at 1KHz, 25°C.
- **INSULATION RESISTANCE:** Measurement shall be made at 25°C after applying for 60 seconds at rated DC voltage or 500VDC, whichever is less.
- **TEMPERATURE COEFFICIENT:** (Refers to operating temperature range of -40°C ~ +85°C).
  - Polyester : 400 ± 200 PPM/°C
  - Polypropylene : -240 ± 80 PPM/°C
- **LONG TERM STABILITY:** Capacitance shall change no more than ±2% for polyester (with the exception of type 92M) and 0.5% for polypropylene (with the exception of type 92P).
- **LIFE TEST:** 1000 hours at 85° C with 150% rated DC voltage.
  - Test criteria:
  - DC/C DD.F. DI.R.
  - Polyester ≤5% 1.2% 0.5 x I.R. min.
  - Polypropylene ≤3% 0.2% 0.5 x I.R. min.
- **SELF HEALING:** A property of metallized capacitors, where any internal arc-over will usually clear itself by vaporizing the deposited metal film. Note that this applies to metallized capacitors only, not film and foil type.
- **FLAME RETARDANT:** Tape meets UL510 (Upon Request), epoxy meets UL94V-0, and cases comply with UL94V-0.
- **LEAD MATERIAL:** Tinned solid copper meets requirements of IEC 384-1, IEC 68-2-20 Solderability Test.
- **PULL TEST:** Follows IEC 384-1 4.13 (IEC 68-2-21 Test Ua). Will sustain 2Kg steady pull in the direction of lead egress and 1Kg steady pull at any 90 degree angle for 60 seconds. After test, capacitor shall show no evidence of damage and pass all electrical requirements.
- **BEND TEST:** Follows IEC 384-1 4.13 (IEC 68-2-21 Test Ub). Will sustain two cycles without breaking when attaching a load of 0.5Kg to the end of the lead and then rotating the capacitor 90 degree from the direction of lead egress, then 180 degree in the opposite direction, then back to the starting point.
- **VIBRATION TEST:** Per IEC 384-1 4.17, capacitor is mounted in apparatus and subjected to a simple harmonic motion with 0.03" amplitude. The entire frequency range, from 10Hz ~ 55Hz, applied for a period of 2 hours in each of 3 mutually perpendicular planes (total 6 hours). After test, capacitor shall show no evidence of physical damage and electrical performance shall not be degraded.
- **HUMIDITY TEST:** Steady state per IEC 384-1 4.22, capacitors are subjected to an environmental test chamber at R.H. 90% ~ 95%, 40°C for 240 hours. After the test, capacitor shall be conditioned at room temperature for 2 hours and meet the following criteria:
  - Capacitance change shall be less than 5% for polyester, 3% for polypropylene.
  - Dissipation factor shall be less than 1.2% for polyester, 0.2% for polypropylene.
  - Insulation resistance shall be over 50% of the minimum requirement.
- **MARKING:** Capacitors, if marked, are legibly and permanently marked with capacitance, tolerance, rated voltage in DC and manufacturer's name "TECATE", TI or symbol: T.
- **PACKING:**
  - Bulk: Includes inner cardboard boxes.
  - Axial Tape & Reel: Boxed reels packed in standard cartons.
  - Radial Tape & Reel (inductive and non-inductive): Boxed reels packed in standard cartons; ammo boxed reels packed in standard cartons.
- **TYPICAL LABEL FORM:**

Reference Order No	P/O: 40520		Packaging date
Description	DESC: 1µF/250VDC/±5%		
T.I. Part Number	901-250/105J		
Quantity	QTY: 100 PCS.      8/3/01		

Optional label information can be included

- Ex: Barcode
- Customer Name
- Customer Part Number
- Etc...

**GENERAL APPLICATION REFERENCE:**

Our film capacitors are widely used in the electronics industry. To help you select the proper TI capacitor we have provided you with the following information:

- (1) **FREQUENCY:** Polyester capacitors with higher dielectric loss are generally suitable for use at frequencies below 10KHz at a comparatively wide range of temperature. Polypropylene, with lower DF is the most popular selection for high frequency and higher pulse current applications although its size is larger and it has a lower temperature range.
- (2) **AC RATING:** The peak value of the superimposed AC plus DC voltage should not exceed the rated DC voltage. The peak voltage against a zero reference shall always be less than the nominal DC voltage rating of the capacitor. Also:

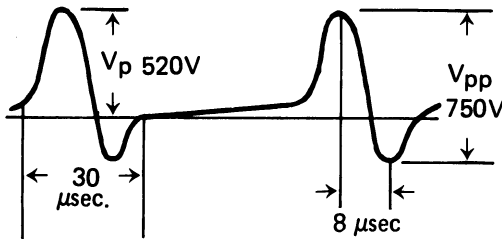

The Vrms voltage derived from the peak voltage shall always be less than the nominal AC voltage rating of the capacitor. Other restrictions may apply.

Vrms - VAC rated; VP - VDC rated  
(Where Vrms =  $V_{pp}/2\sqrt{2}$ )

- 3) **PULSE CURRENT:** Proper selection of TI capacitors can meet various applications when stressed under pulse or non-sinusoidal voltage. For instance:
 

2013S	:	up to 10A P-P at 15KHz and up to 35,000V/microsecond
2114	:	up to 30V/microsecond for cap. < 0.1μF.
814/2014	:	up to 800V/microsecond for cap. < 0.1μF.

For DeltaVoltage / Delta Time (DV/DT) ratings, see specific product type data.

## TEMPERATURE CHARACTERISTICS

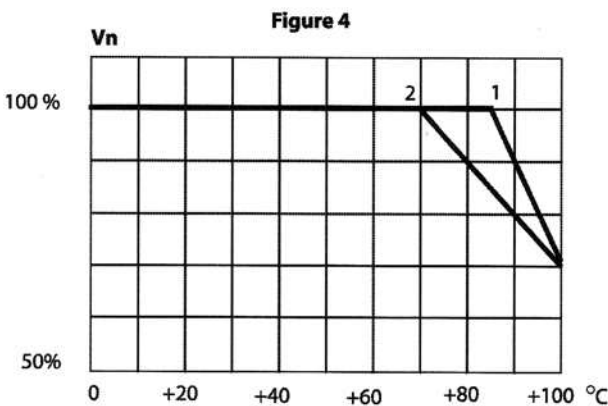
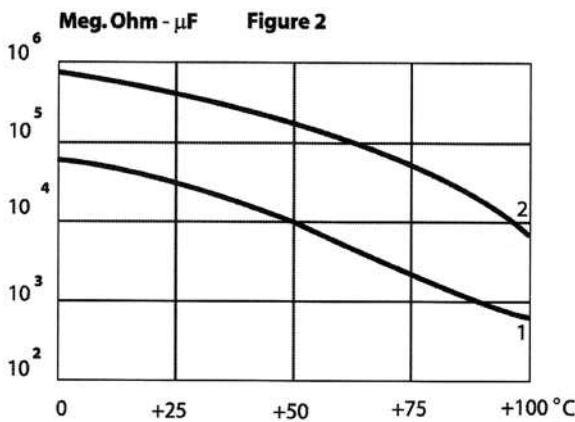
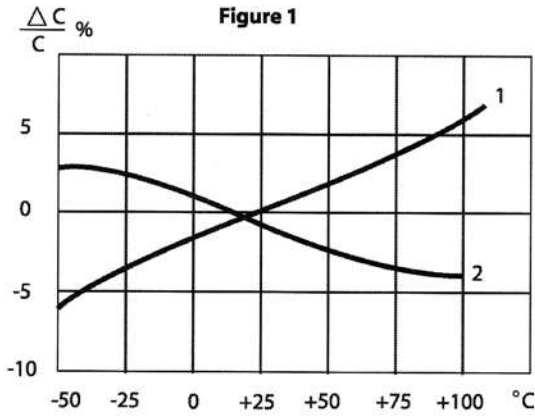

Curve 1: Polyester dielectric.

Curve 2: Polypropylene dielectric.

Excludes Types 92, 92M, 5214, & 5224.

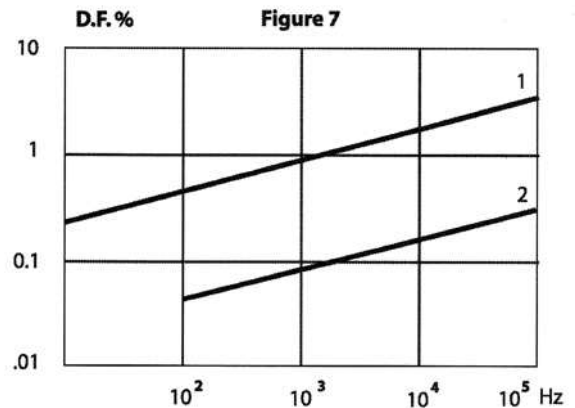
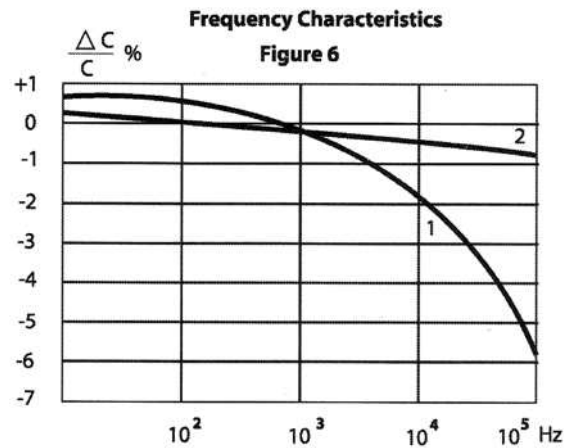
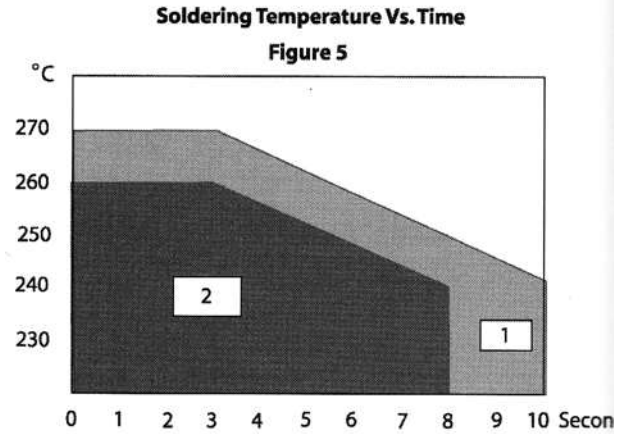

## AC RATED VOLTAGE/FREQUENCY DERATING CHARACTERISTICS

Figure 8 to 10 for 800, 900, & 6000 series capacitors with polyester dielectric (excluding types 92, 92M, & 914D). For in line use only, not recommended for use in across the line applications.

Figure 11 to 13 for 2000 & 7000 series capacitors with polypropylene or metallized polypropylene dielectric (excluding type 92P).

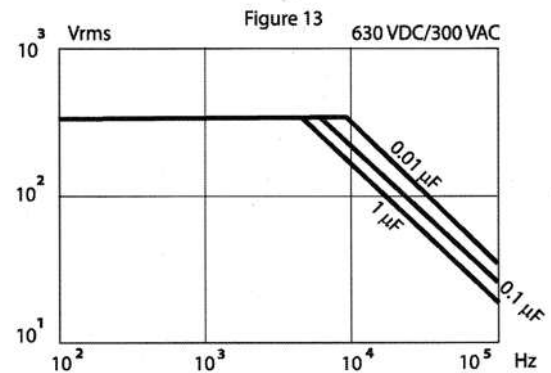
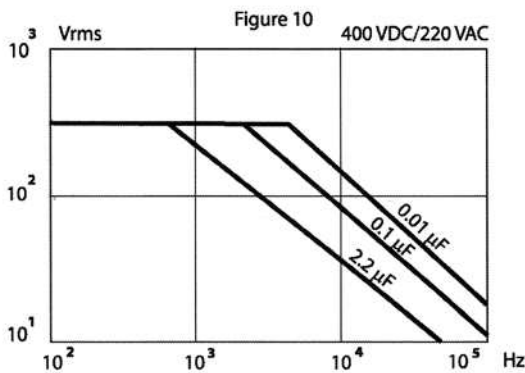
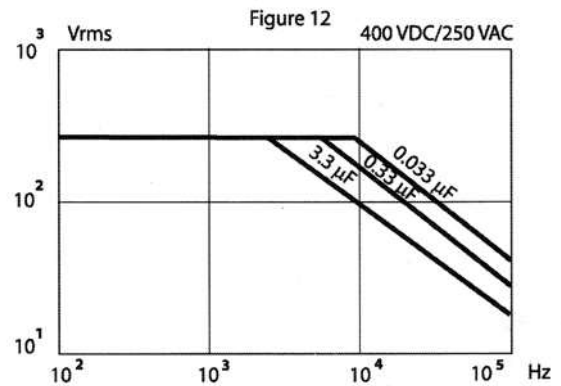
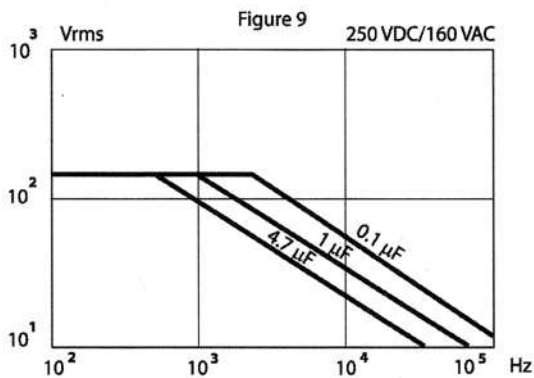
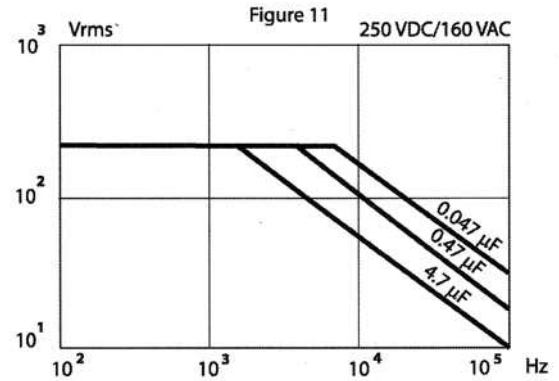
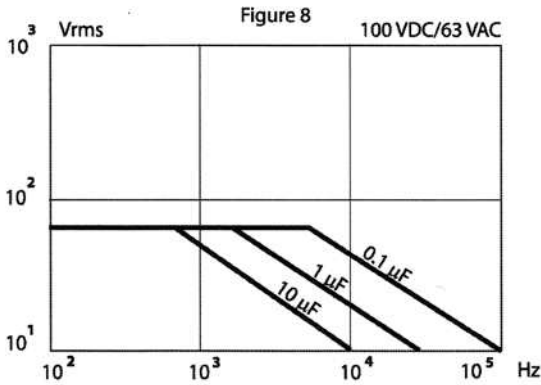

## TAPE AND REEL FOR RADIAL LEAD CAPACITOR

### Crimped Lead Taping

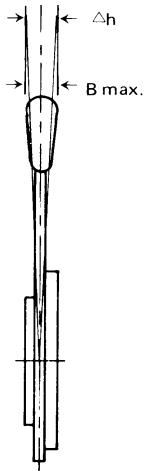
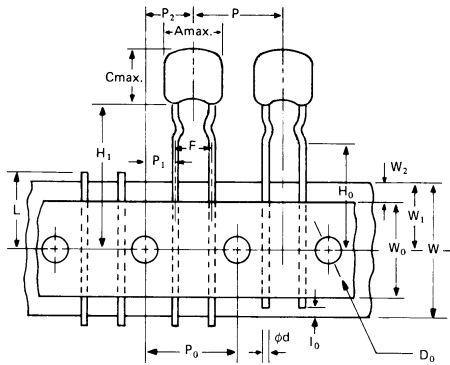

### Straight Lead Taping

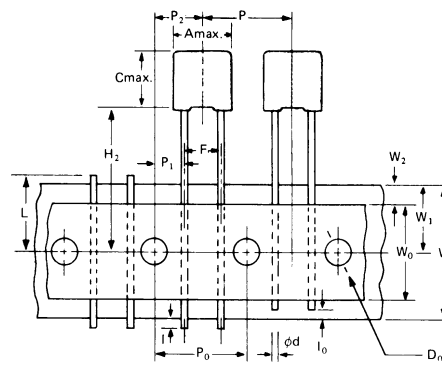

Dimensions (mm (inch))		
-d	0.5 ± 0.05	(0.0197 ± 0.002)
P	12.7 ± 1.0	(0.5 ± 0.0394)
P0	12.7 ± 0.2	(0.5 ± 0.008)
P2	6.35 ± 1.3	(0.25 ± 0.051)
P1	3.85 ± 0.5	(0.152 ± 0.020)
F	5.0 ± 0.8	(0.197 ± 0.0315)
Dh	0 ± 2.0	(0 ± 0.0787)
W	18.0 ± 0.5	(0.709 ± 0.020)
W1	9.0 ± 0.5	(0.354 ± 0.020)
H1	20.0 ± 0.75	(0.787 ± 0.030)
H2	16 -18.5	(0.63 -0.73, ± 0.020)
H0	16.0 ± 0.5	(0.63 ± 0.020)
I	2.0 maximum	(0.079 maximum)
I0	7.0 maximum	(0.276 maximum)
-D0	4.0 ± 0.2	(0.157 ± 0.008)
W0	6.0 minimum	(0.492 minimum)
t	0.7 ± 0.2	(0.028 ± 0.008)
W2	3.0 maximum	(0.118 maximum)
L	11.0 maximum	(0.433 maximum)

For sizes other than 5mm, see tech. bulletin.

## PACKING

### Ammo Box Packing

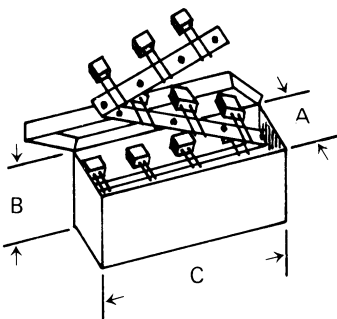

#### DIMENSIONS (mm (INCH))

	EIA Std.	TI Spec.
A	55 max. ( 2.17 max.)	52mm
B	335 max. (13.19 max.)	260mm
C	335 max. (13.19 max.)	330mm

### Reel Packing

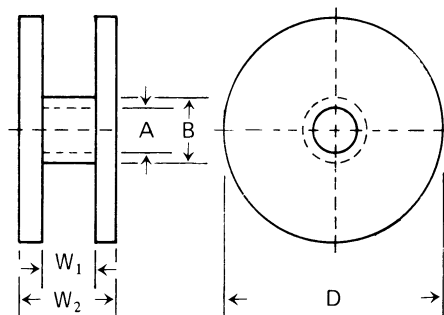

#### EIA Std.

#### TI Spec.

A	14-30 (0.55, -0.18)	15mm -1, +15
B	80 min. (3.15 min.)	80mm max.
D	360 max. (14.57 max.)	370mm max.
W <sub>1</sub>	45 -1, +6.2 (1.77 -0.04, +0.24)	45mm -1, +6.2
W <sub>2</sub>	55 max. (2.17 max.)	55mm max.

**TAPE & REEL OF AXIAL LEAD CAPACITORS FOR AUTOMATIC INSERTION  
EIA STANDARD EIA-296**

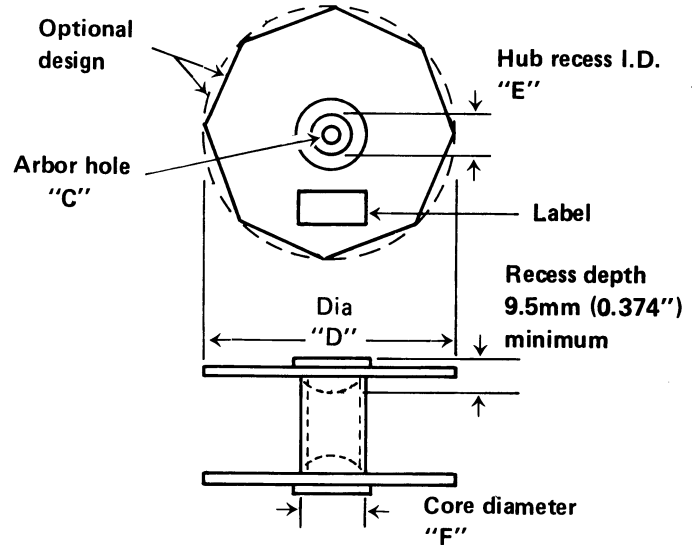
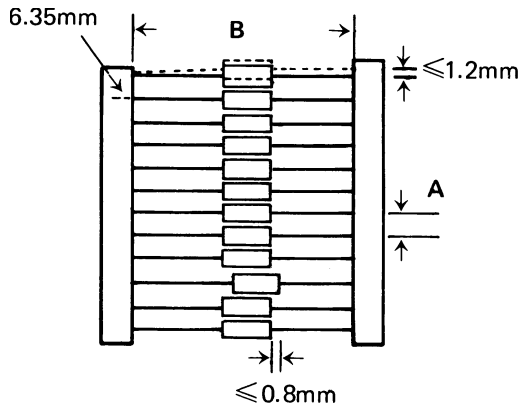

Capacitor Body Diameter	Capacitor Pitch "A" ± 0.5mm (0.02")
- 5mm (- 0.195")	5mm or 0.200"
5.01mm - 10mm (0.197" - 0.394")	10mm or 0.400"
10.01mm - 15mm (0.394" - 0.591")	15mm or 0.600"

Capacitor Body Length	Inside Tape Spacing "B" ± 1.5mm (0.059")
16.50mm ( 0.65")	52.4mm or 2.062"
16.51mm - 28.45mm (0.651" - 1.12")	63.5mm or 2.500"
28.46mm - 37.00mm (1.121" - 1.45")	73.0mm or 2.874"

	C	D	E	F
EIA Std.	13.9mm - 38.1mm (0.547" - 1.5")	76.2mm - 355.6mm (3" - 14")	28.6mm - 78.0mm (1.126" - 3.071")	34.5mm - 92.0mm (1.358" - 3.626")
TI Spec.	16.0mm (0.63")	355.0mm (13.97")	50.0mm (1.97")	60.0mm (2.36")

Capacitor Body Diameter	Pitch	Quantity (pcs/reel)
5.0mm	5mm	4000 maximum
5.1mm - 7.0mm	10mm	2000 maximum
7.1mm - 9.5mm	10mm	1000 maximum

**POLYESTER, POLYETHYLENE TEREPHTHALATE (PET), INDUCTIVELY WOUND, EPOXY COATED**

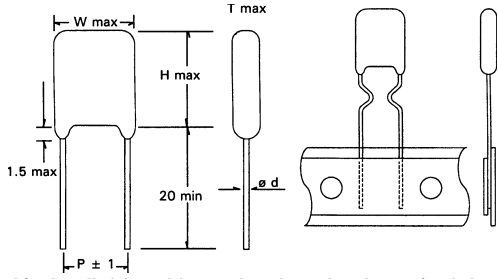

- A) Available with cut leads 5.0m long ( $\pm 1.0$ mm)
- B) Available cut and formed as shown above – style 7 (see part numbering system).

**SPECIFICATIONS**

Performance Characteristics	
Operating Temperature Range	-40°C ~ +85°C.
Voltage Range	100VDC.
Withstanding Voltage (between leads)	2.5 times rated voltage for 2 seconds.
Capacitance Range	0.001 $\mu$ F ~ 0.47 $\mu$ F.
Capacitance Tolerance	$\pm 5\%$ , $\pm 10\%$ , & $\pm 20\%$ .
Maximum Dissipation Factor % (20°C, 1KHz)	<1.0.
Minimum Insulation Resistance	30000M $\Omega$ (< 0.33 $\mu$ F). 10000M $\Omega$ (> 0.33 $\mu$ F).

**PART NUMBERING**

Part Number Example: 92-100/102J3F							
<b>92</b>	-	<b>100</b>	/	<b>102</b>	<b>J</b>	<b>3</b>	<b>F</b>
Type		Rated DC Voltage		Capacitance Code (pF)*	Tolerance Code	Lead Spacing	RoHs Compliant

\* Capacitance Code: First two digits represent significant figures, third digit represents multiplier (number of zeros).