

### THROUGH HOLE

711-025/101M6x11TR/2.5F

7	1	1	-	0	2	5	/	1	0	1	M	6	x	11	TR	/	2.5	F
Type Number			Voltage			Capacitance		Capacitance Tolerance			Case Size			Lead Config. and Packing		TR or TA Lead Space		RoHS Compliant

Type	WVDC	Code	Cap. (μF)	Code	Cap. Tol. (%)	Code	Size	Code		Lead Space	
711	6.3	6R3	0.1	0R1	±5	J	6.3 x 11	FC	Formed & Cut	Blank	5mm
	10	010	1	010	±10	K	***See note.	C	Cut Leads	2.5	2.5mm
	100	100	2.2	2R2	±20	M		FL	Formed & Long Leads	3.5	3.5mm
			10	100	-10 ~ +30	Q		TA	Tape & Ammo, TAN=neg. first *		
			100	101	-10 ~ +50	T		TR	Tape & Reel, TRN=neg. first *		
								-	Bulk		
								#	Computer Code		

\*\*See note.

#### \*\*Capacitance Note:

Expressed in microFarad. The first two digits are significant figures, the third is the number of zeros. If four digits are present, the first three digits are significant figures, and the fourth is the number of zeros.

#### \*\*\*Case Size Note:

Decimal size is rounded to the next integer. Ex. Case size 6.3x11 is represented as 6x11.

\* TR/TA Available for sizes up to 10mm diameter.

### LEAD CUT AND FORMING (RADIAL TYPE)

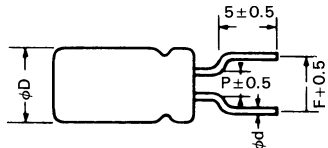
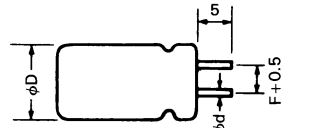
Forming Method	Code	Shape	Dimensions			
			D	dø	F	P
Forming Cut (5Ø ~ 8Ø)	FC		5	0.5	5.0	2.0
Cut (10Ø ~ 22Ø)	C		6.3	0.5	5.0	2.5
			8	0.6	5.0	3.5
			10	0.6	5.0	
			13	0.6	5.0	
			16	0.8	7.5	
			18	0.8	7.5	
			22	0.8	10.0	

Other leads configuration available on request.

Due to the continued improvement of capacitor manufacturing technology, other sizes and values, not described in this catalog, may now be available. Please contact Factory or Area Representative for the latest data.

### IMPORTANT CONSIDERATION IN THE USE OF CAPACITORS

#### 1. QUALITY CONTROL TESTING PROCEDURE

TI capacitors are produced on automatic machinery using computer control and SPC techniques. All capacitors are 100% tested for capacitance, dissipation factor and dielectric strength. Distribution curves of final test reports can be obtained for all production lots.

#### 2. CAPACITOR MARKING AND POLARIZATION

Aluminum electrolytic capacitors for DC applications are normally polarized. The polarity marking is indicated as follows:

- Stripe or arrow marking: usually with minus (-) sign on the body of the capacitors indicates negative polarity (cathode). Conversely a (+) sign would indicate positive polarity (anode).
- A shorter lead wire, on radial leaded capacitors, indicates negative polarity.

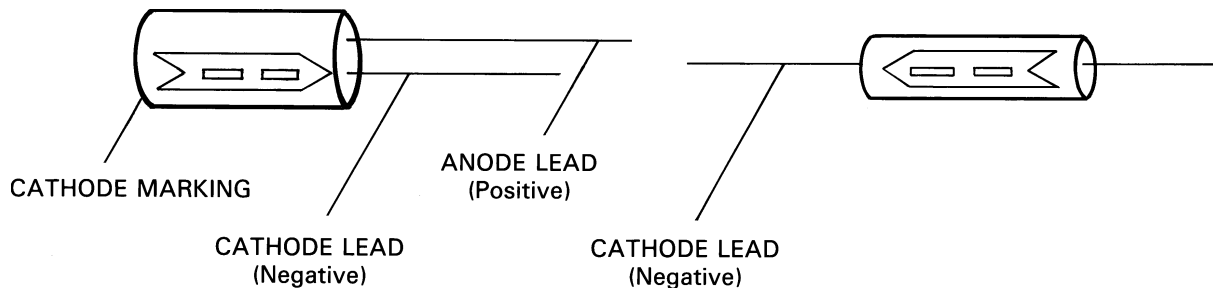

Reverse voltage, in excess of 1.5VDC, will cause anodization of the cathode foil shortening the life expectancy of capacitor with one or more of the following modes.

- High leakage current.
- Heat rise.
- Decrease in capacitance.
- Internal rapid gas formation with possible vent activation.

If reverse voltage or frequent polarity changes are expected, or if the polarity is unknown, a non-polar (NP) capacitor should be used.

#### 3. NON-POLAR CAPACITORS

Limited reverse or AC voltage can be tolerated by non-polar capacitors under certain conditions. Non-polar capacitors are designed for use in those circuits where polarity reversal can occur. Under no circumstances may the peak voltage exceed the rated voltage of the capacitor.

CAUTION: The AC ripple current ratings are not to be exceeded.

Warning: a non-polar capacitor (NP) is not necessarily suitable for AC applications.

#### 4. TERMINAL STRESS

Please note: Pull or Bend tests specified by EIA RS-186-6E applies to wires and terminals welded to outside aluminum case or riveted terminal. It does not apply to small electrolytic capacitors where the leads egress from the rubber, or similar compound, end seal.

Excessive force or stress to lead wires of the capacitors should be avoided. The consequences of pulling, pushing or bending the leads may result in high leakage current, electrolyte seepage and possibly open/short circuit conditions.

Warning: The following examples of capacitor handling abuses are characteristic of incipient failures.

- Bending or straightening of the capacitor after soldering.
- Forcing lead penetration in PC board where hole spacing does not match capacitor lead spacing.
- Picking up the PC board by holding the soldered capacitor.
- Inserting the leads into a captive test fixture by pushing on the capacitor top.

**IMPORTANT CONSIDERATION IN THE USE OF CAPACITORS (CONT.)**

5. SAFETY VENT

To operate correctly, the safety vent should have an unobstructed 3mm space in its proximity.

6. STORAGE

High level of humidity will affect wire solderability and high temperature will increase the DC leakage current and reduce the expected operating life. If capacitor is stored for a long period of time, or under adverse conditions, the capacitor should be reconditioned. DC voltage should be applied gradually, at 25°C, up to rated voltage. The voltage to be held until DC leakage currents comes down to specified value or less.

7. LEAKAGE TEST PROCEDURE

Capacitor must be preconditioned at 25°C at rated DC voltage for 30 minutes at not less than 18 hours nor more than 24 hours prior to testing. The leakage current shall be measured at the time specified for each type after application of maximum rated voltage at 25 °C. A resistance of 1KΩ shall be placed in series with the capacitor under test. The leakage current shall be calculated as specified for its particular type.

8. CLEANING

\*No guarantees or warranties are expressed or implied with the use of solvents.

Tecate recommends the use of CFC Substitutes whenever possible.

Industrial standards such as EIA RS-395 and Military Specification MIL C39018 caution against the use of halogenated hydrocarbon solvent in cleaning boards containing aluminum electrolytic capacitors. (Carbon tetrachloride, Chloroethene, Freon TMC and TMS, Methylene chloride, Perchloroethylene, Trichloroethane, Trichloroethylene, etc.). Should any of these solvents seep into electrolytic capacitors around or through their seals, they will attack the internal section and the resultant corrosion will cause the capacitor to fail over time.

The Tecate capacitors listed in this catalog can be used with some halogenous cleaning solvents such as Freon TF, Freon TE and Freon TES within 5 minutes either by immersion, steaming, ultrasonic cleaning or combinations of same.

9. SURGE VOLTAGE

The surge voltage rating is the maximum DC over-voltage to which the capacitor may be subjected for short periods not exceeding 30 seconds and at infrequent intervals of not more than five minutes in accordance with EIA RS-395 standards or JIS C5141 specifications.

10. SHELF LIFE

When Aluminum capacitors have been stored for long periods of time without having voltage applied, leakage current will be very high when voltage is applied. This can cause internal heating and pressure build-up inside the case (sometimes enough to rupture the vent). The amount of time that capacitors can be stored safely depends on the voltage rating of the capacitor and the storage environment. Humidity levels should be under 50% and temperature should be kept lower than the operating temperature rating of the capacitor. TECATE recommends reconditioning any capacitors that have been stored for a period of greater than 12 months from the date of manufacture. Reconditioning is accomplished by applying a low voltage through a 1K ohm series resistor and slowly ramping the voltage up to the rated voltage. Lower voltage capacitors have a longer shelf life than high voltage capacitors before needing to be reconditioned.

<b>Rated Voltage</b>	6.3	10	16	25	35	50	63	80	100	160	200	250	315	350	400	450
<b>Rated Surge Voltage</b>	8	13	20	32	44	63	79	100	125	200	250	300	365	400	450	500

Wire Size		Tensile Force	
AWG	Dia. (mm)	Lbs	Kg
25-24	0.45-0.5	1.1	0.5
22-20	0.6-0.8	2.2	1.0
18	1.0	5	2.0

Conversion	
mm	Inches
0.5	0.020
0.6	0.024
0.8	0.032
1.0	0.039
2.0	0.079
2.5	0.098
3.5	0.138
5.0	0.197
6.0	0.236
7.5	0.295
8.0	0.315
10	0.394
11.5	0.453
12.5	0.492
13	0.512
16	0.63
18	0.709
20	0.787
22	0.866
25	0.984
30	1.181
31	1.221
32	1.260
36	1.417
40	1.575
41	1.614
52	2.047
64	2.25
71	2.796
72	2.835
77	3.032

Symbol	Nominal Value	Tolerance	Remarks
W	52, 63, 73	±1.5	
R	2 maximum		
P	10, 15	±0.5	10 for 5Ø ~ 8Ø, 15 for 10Ø
Z	1.2 maximum		
L	W/2	±1.2	W = 52, L' = 71; W = 63, L' = 80
T	6	±1	

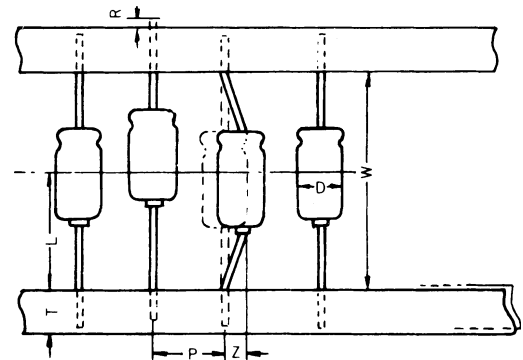

**Packing 1. Reel pack**

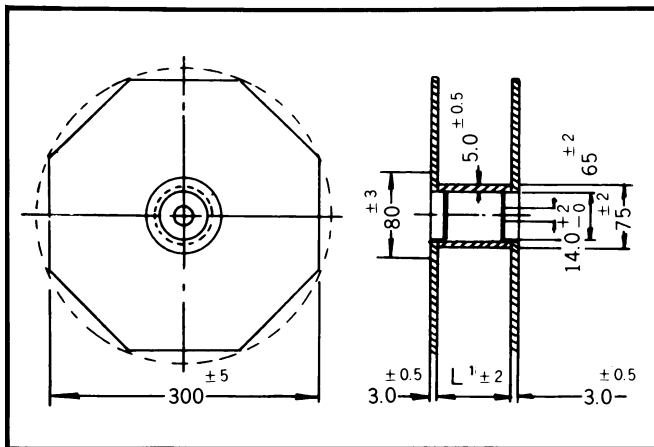

dØ	Quantity (pcs)
5	1200
6.3	1000
8	800
10	500

**ORIENTATION, PER EIA STD RS-468**

Radial lead taping (the cathode lead is the last lead to leave the reel). Available for capacitors with diameters of 4, 5, 6.3, 8 and 10mm.

Symbol	Case Size			Tolerance	Remarks
	4 x 7 5 x 7 6.3 x 7	5 x 11 6.3 x 11	8 x 11.5		
d-	0.45	0.5	0.6	±0.05	
P			12.7	±1.0	
P0			12.7	±0.2	
P1			3.85	±0.7	
P2			6.35	±1.0	
F			5.0	+0.8, -0.2	
-H			0	±2.0	
W			18	±0.5	
W0		12.5 minimum			
W1		9.0		+0.75, -0.5	
W2		3.0 maximum			
H	17.5	18.5	20.0	±0.75	For ammo pack.
H0		16.0		±0.5	
H1		32.25 maximum			For reel pack.
I		1.0 maximum			
D0-		4.0		±0.3	
t		0.7		±0.2	
L		11.0 maximum			

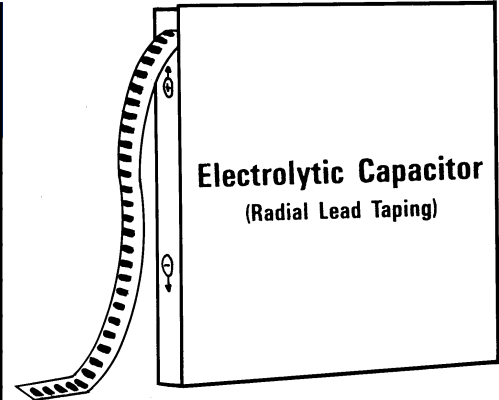

Symbol	D- = 10	Tolerance
d-	0.6	±0.05
P	12.7	±1.0
P0	12.7	±0.3
P1	3.85	±0.7
P2	6.35	±1.3
F	5.0	+0.8, -0.2
-H	0	±2.0
W	18.0	±0.5
W0	12.5 minimum	
W1	9.0	+0.75, -0.5
W2	3.0 maximum	
H	18.5	±0.75
H0	1.0 maximum	
H1	4.0	±0.3
I	0.7	±0.2
D0-	11.0 maximum	

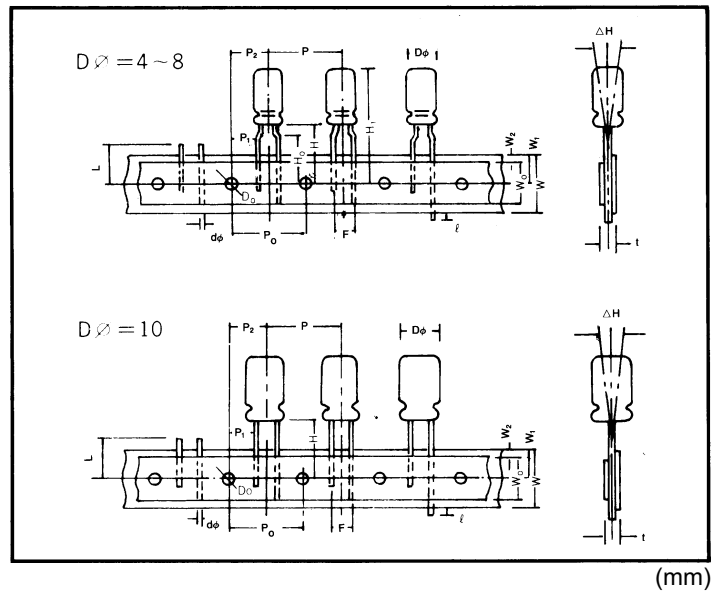

(TR)

2. Ammo pack

(TA)

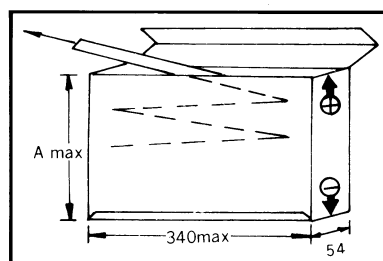
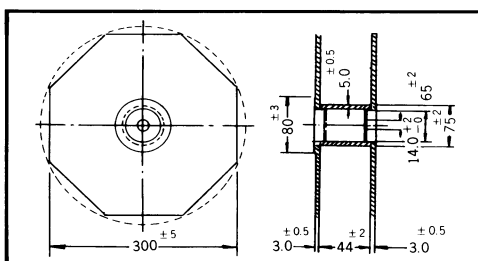

D-	Reel		Ammo	
	Quantity (pcs)	Quantity (pcs)	A	
4	1500	2000	285	
5	1200	2000	285	
6.3	1000	2000	325	
8	800	1000	285	
10	500	500		