



# STFW3N150 STP3N150, STW3N150

N-channel 1500 V, 6  $\Omega$ , 2.5 A, PowerMESH™ Power MOSFET  
in TO-220, TO-247, TO-3PF

## Features

Type	V <sub>DSS</sub>	R <sub>DS(on)</sub> max.	I <sub>D</sub>	P <sub>TOT</sub>
STFW3N150	1500 V	< 9 $\Omega$	2.5 A	63 W
STP3N150	1500 V	< 9 $\Omega$	2.5 A	140 W
STW3N150	1500 V	< 9 $\Omega$	2.5 A	140 W

- 100% avalanche tested
- Intrinsic capacitances and Q<sub>g</sub> minimized
- High speed switching
- Fully isolated TO-3PF plastic package
- Creepage distance path is 5.4 mm (typ.) for TO-3PF

## Application

Switching applications

## Description

Using the well consolidated high voltage MESH OVERLAY™ process, STMicroelectronics has designed an advanced family of very high voltage Power MOSFETs with outstanding performances. The strengthened layout coupled with the company's proprietary edge termination structure, gives the lowest R<sub>DS(on)</sub> per area, unrivalled gate charge and switching characteristics.

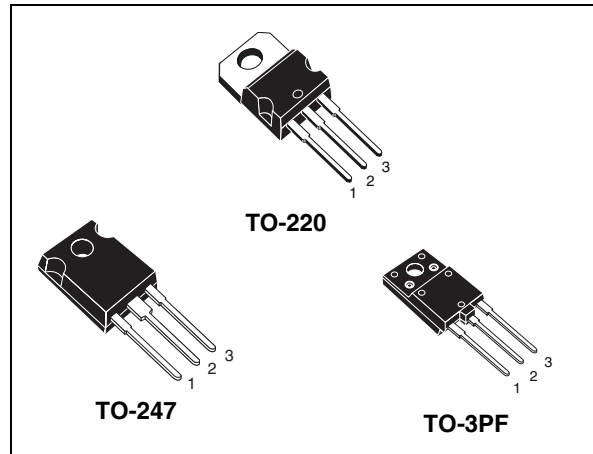

Figure 1. Internal schematic diagram

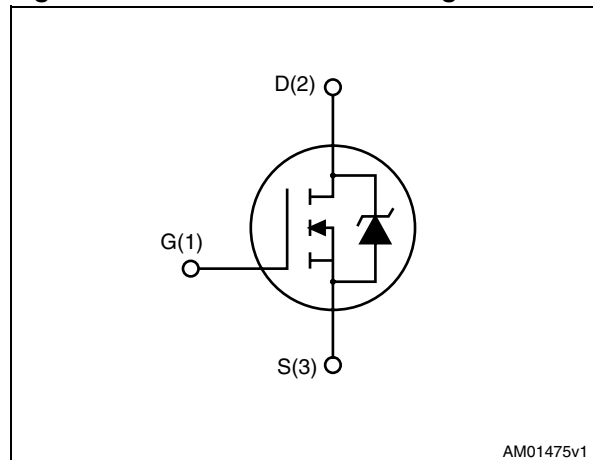

Table 1. Device summary

Order codes	Marking	Package	Packaging
STFW3N150	3N150	TO-3PF	Tube
STP3N150	3N150	TO-220	Tube
STW3N150	3N150	TO-247	Tube

## Contents

<b>1</b>	<b>Electrical ratings</b> .....	<b>3</b>
<b>2</b>	<b>Electrical characteristics</b> .....	<b>4</b>
	2.1 Electrical characteristics (curves) .....	6
<b>3</b>	<b>Test circuits</b> .....	<b>9</b>
<b>4</b>	<b>Package mechanical data</b> .....	<b>10</b>
<b>5</b>	<b>Revision history</b> .....	<b>14</b>

# 1 Electrical ratings

**Table 2. Absolute maximum ratings**

Symbol	Parameter	Value		Unit
		TO-220,TO-247	TO-3PF	
$V_{DS}$	Drain-source voltage ( $V_{GS} = 0$ )	1500		V
$V_{GS}$	Gate-source voltage	$\pm 30$		V
$I_D$	Drain current (continuous) at $T_C = 25\text{ }^\circ\text{C}$	2.5	2.5 <sup>(1)</sup>	A
$I_D$	Drain current (continuous) at $T_C = 100\text{ }^\circ\text{C}$	1.6	1.6 <sup>(1)</sup>	A
$I_{DM}^{(1)}$	Drain current (pulsed)	10	10 <sup>(1)</sup>	A
$P_{TOT}$	Total dissipation at $T_C = 25\text{ }^\circ\text{C}$	140	63	W
$V_{ISO}$	Insulation withstand voltage (RMS) from all three leads to external heat sink ( $t=1\text{ s}; T_C=25\text{ }^\circ\text{C}$ )		3500	V
	Derating factor	1.12	0.5	W/ $^\circ\text{C}$
$T_{stg}$	Storage temperature	-50 to 150		$^\circ\text{C}$
$T_j$	Max. operating junction temperature	150		$^\circ\text{C}$

1. Pulse width limited by safe operating area

**Table 3. Thermal data**

Symbol	Parameter	TO-220	TO-247	TO-3PF	Unit
$R_{thj-case}$	Thermal resistance junction-case max	0.89		2	$^\circ\text{C}/\text{W}$
$R_{thj-amb}$	Thermal resistance junction-ambient max	62.5	50	50	$^\circ\text{C}/\text{W}$
$T_j$	Maximum lead temperature for soldering purpose	300			$^\circ\text{C}$

**Table 4. Avalanche characteristics**

Symbol	Parameter	Max value	Unit
$I_{AR}$	Avalanche current, repetitive or not-repetitive (pulse width limited by $T_j$ max)	2.5	A
$E_{AS}$	Single pulse avalanche energy (starting $T_j = 25\text{ }^\circ\text{C}$ , $I_D = I_{AR}$ , $V_{DD} = 50\text{ V}$ )	450	mJ

## 2 Electrical characteristics

( $T_{\text{case}} = 25\text{ °C}$  unless otherwise specified)

**Table 5. On /off states**

Symbol	Parameter	Test conditions	Min.	Typ.	Max.	Unit
$V_{(\text{BR})\text{DSS}}$	Drain-source breakdown voltage	$I_{\text{D}} = 1\text{ mA}$ , $V_{\text{GS}} = 0$	1500			V
$I_{\text{DSS}}$	Zero gate voltage drain current ( $V_{\text{GS}} = 0$ )	$V_{\text{DS}} = \text{Max rating}$ $V_{\text{DS}} = \text{Max rating}$ , $T_{\text{C}} = 125\text{ °C}$			10 500	$\mu\text{A}$ $\mu\text{A}$
$I_{\text{GSS}}$	Gate-body leakage current ( $V_{\text{DS}} = 0$ )	$V_{\text{GS}} = \pm 30\text{ V}$			$\pm 100$	nA
$V_{\text{GS(th)}}$	Gate threshold voltage	$V_{\text{DS}} = V_{\text{GS}}$ , $I_{\text{D}} = 250\text{ }\mu\text{A}$	3	4	5	V
$R_{\text{DS(on)}}$	Static drain-source on resistance	$V_{\text{GS}} = 10\text{ V}$ , $I_{\text{D}} = 1.3\text{ A}$		6	9	$\Omega$

**Table 6. Dynamic**

Symbol	Parameter	Test conditions	Min.	Typ.	Max.	Unit
$g_{\text{fs}}^{(1)}$	Forward transconductance	$V_{\text{DS}} = 30\text{ V}$ , $I_{\text{D}} = 1.3\text{ A}$	-	2.6	-	S
$C_{\text{iSS}}$ $C_{\text{OSS}}$ $C_{\text{rSS}}$	Input capacitance Output capacitance Reverse transfer capacitance	$V_{\text{DS}} = 25\text{ V}$ , $f = 1\text{ MHz}$ , $V_{\text{GS}} = 0$	-	939 102 13.2	-	pF pF pF
$C_{\text{OSS eq.}}^{(2)}$	Equivalent output capacitance	$V_{\text{DS}} = 0$ to $1200\text{ V}$ , $V_{\text{GS}} = 0$	-	100	-	pF
$R_{\text{g}}$	Gate input resistance	$f = 1\text{ MHz}$ Gate DC Bias = 0 Test signal level = 20 mV open drain	-	4	-	$\Omega$
$Q_{\text{g}}$ $Q_{\text{GS}}$ $Q_{\text{GD}}$	Total gate charge Gate-source charge Gate-drain charge	$V_{\text{DD}} = 1200\text{ V}$ , $I_{\text{D}} = 2.5\text{ A}$ , $V_{\text{GS}} = 10\text{ V}$ (see Figure 19)	-	29.3 4.6 17	-	nC nC nC

1. Pulsed: Pulse duration = 300  $\mu\text{s}$ , duty cycle 1.5%

2.  $C_{\text{OSS eq.}}$  is defined as a constant equivalent capacitance giving the same charging time as  $C_{\text{OSS}}$  when  $V_{\text{DS}}$  increases from 0 to 80%  $V_{\text{DSS}}$

**Table 7. Switching times**

Symbol	Parameter	Test conditions	Min.	Typ.	Max.	Unit
$t_{d(on)}$	Turn-on delay time	$V_{DD} = 750\text{ V}$ , $I_D = 1.25\text{ A}$ , $R_G = 4.7\ \Omega$ , $V_{GS} = 10\text{ V}$ (see Figure 18)	-	24	-	ns
$t_r$	Rise time		-	47	-	ns
$t_{d(off)}$	Turn-off-delay time		-	45	-	ns
$t_f$	Fall time		-	61	-	ns

**Table 8. Source drain diode**

Symbol	Parameter	Test conditions	Min.	Typ.	Max.	Unit
$I_{SD}$	Source-drain current		-		2.5	A
$I_{SDM}^{(1)}$	Source-drain current (pulsed)				10	A
$V_{SD}^{(2)}$	Forward on voltage	$I_{SD} = 2.5\text{ A}$ , $V_{GS} = 0$	-		1.6	V
$t_{rr}$	Reverse recovery time	$I_{SD} = 2.5\text{ A}$ , $di/dt = 100\text{ A}/\mu\text{s}$ $V_{DD} = 60\text{ V}$ (see Figure 20)	-	410		ns
$Q_{rr}$	Reverse recovery charge		-	2.4		$\mu\text{C}$
$I_{RRM}$	Reverse recovery current		-	11.7		A
$t_{rr}$	Reverse recovery time	$I_{SD} = 2.5\text{ A}$ , $di/dt = 100\text{ A}/\mu\text{s}$ $V_{DD} = 60\text{ V}$ , $T_J = 150\text{ }^\circ\text{C}$ (see Figure 20)	-	540		ns
$Q_{rr}$	Reverse recovery charge		-	3.3		$\mu\text{C}$
$I_{RRM}$	Reverse recovery current		-	12.3		A

1. Pulse width limited by safe operating area

2. Pulsed: pulse duration = 300  $\mu\text{s}$ , duty cycle 1.5%

## 2.1 Electrical characteristics (curves)

Figure 2. Safe operating area for TO-3PF

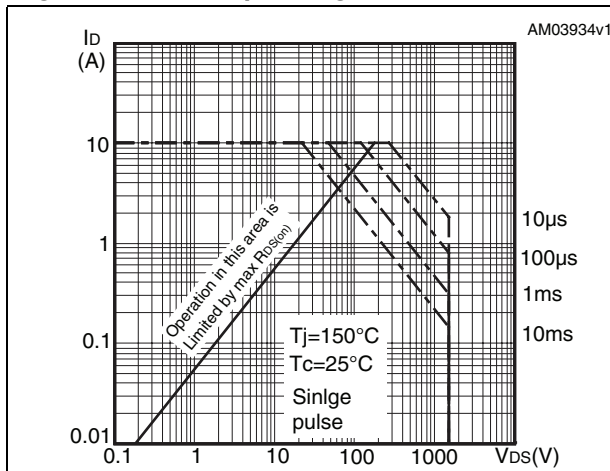

Figure 3. Thermal impedance for TO-3PF

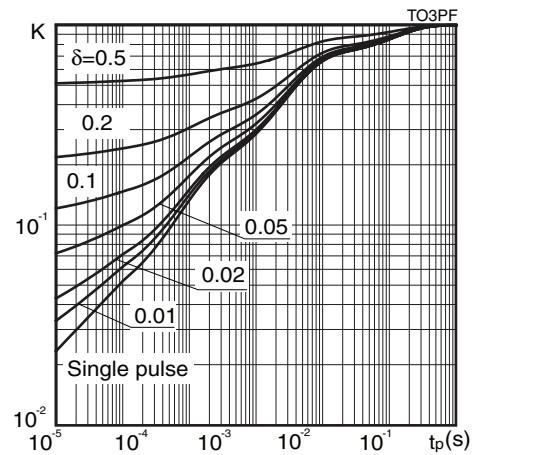

Figure 4. Safe operating area for TO-220

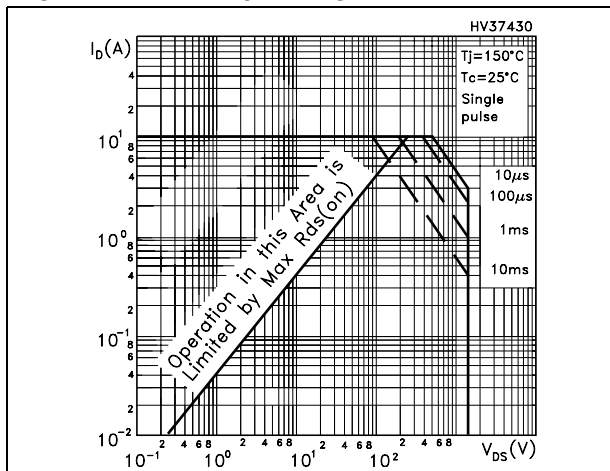

Figure 5. Thermal impedance for TO-220

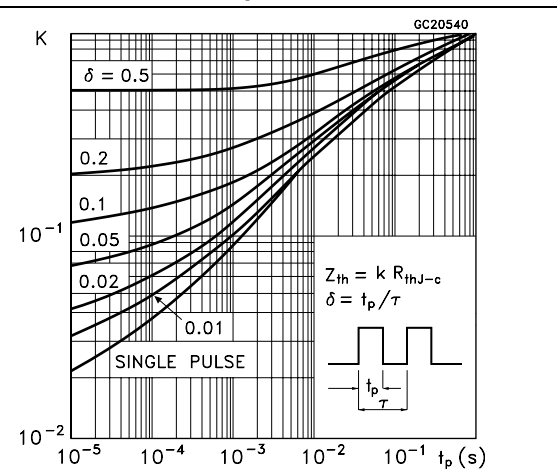

Figure 6. Safe operating area for TO-247

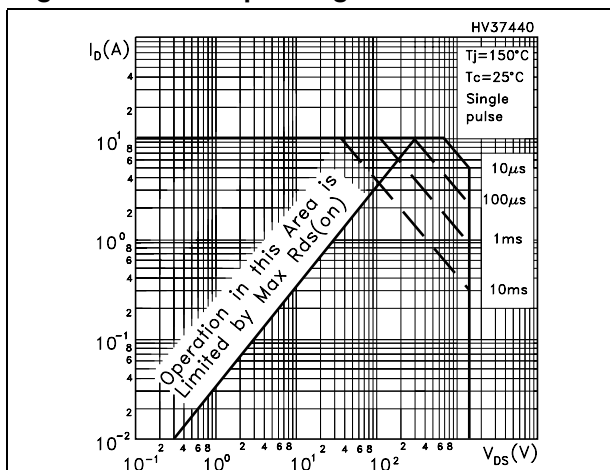

Figure 7. Thermal impedance for TO-247

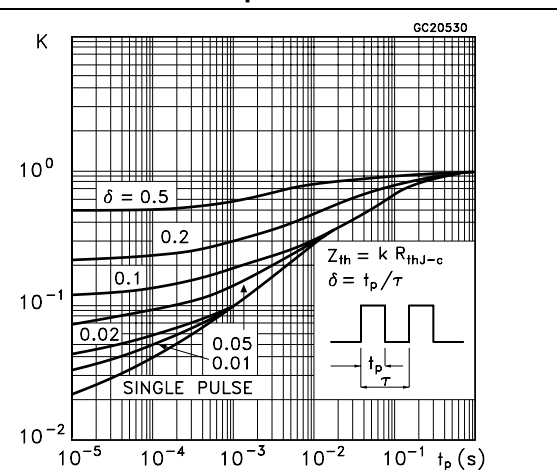

Figure 8. Output characteristics

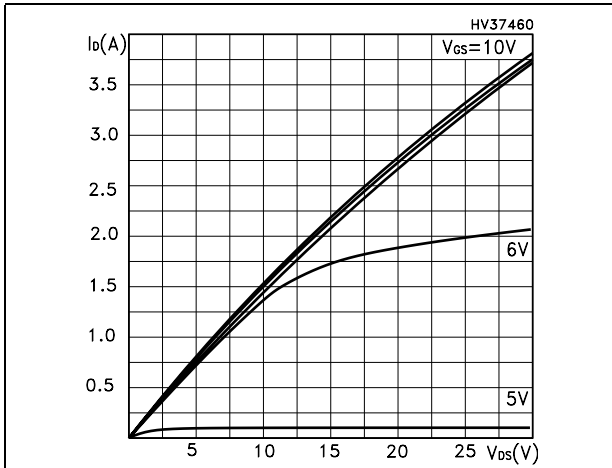

Figure 9. Transfer characteristics

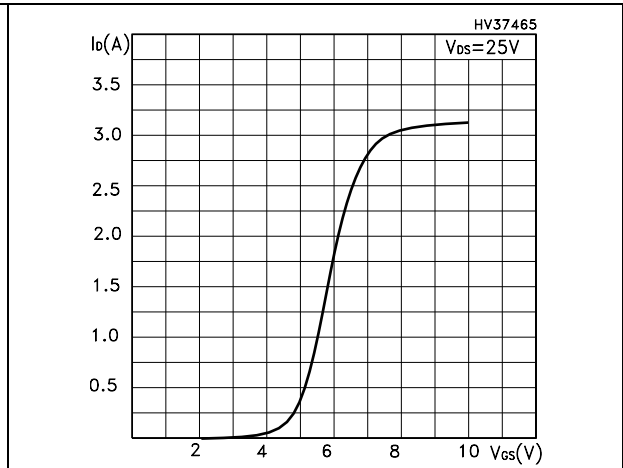

Figure 10. Normalized  $BV_{DSS}$  vs. temperature

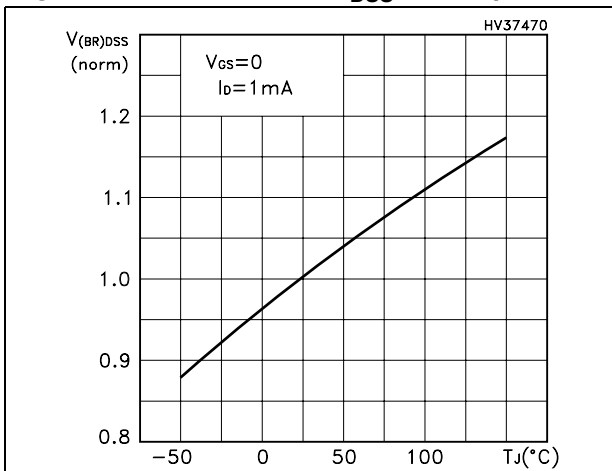

Figure 11. Static drain-source on resistance

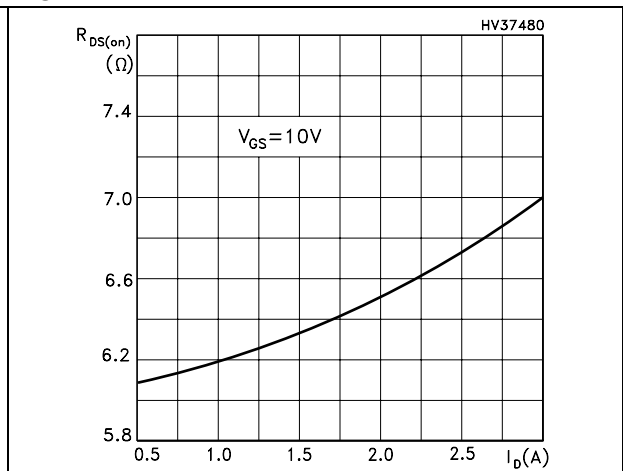

Figure 12. Gate charge vs. gate-source voltage

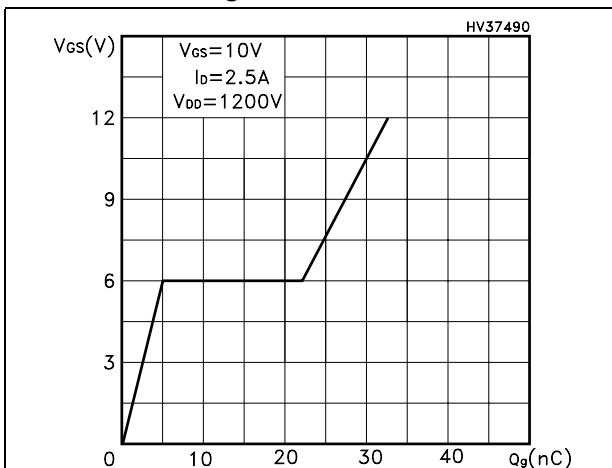

Figure 13. Capacitance variations

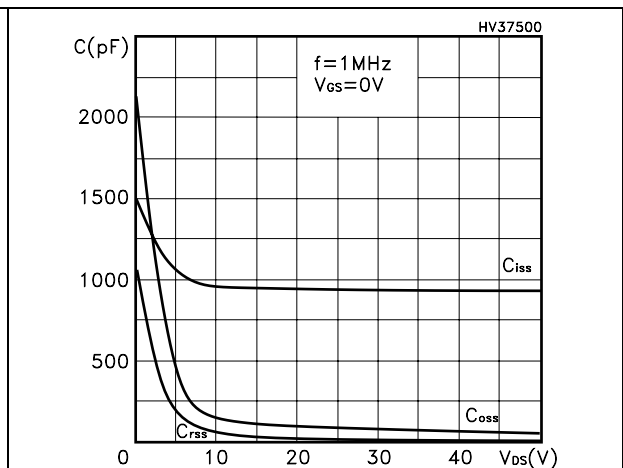

Figure 14. Normalized gate threshold voltage vs. temperature

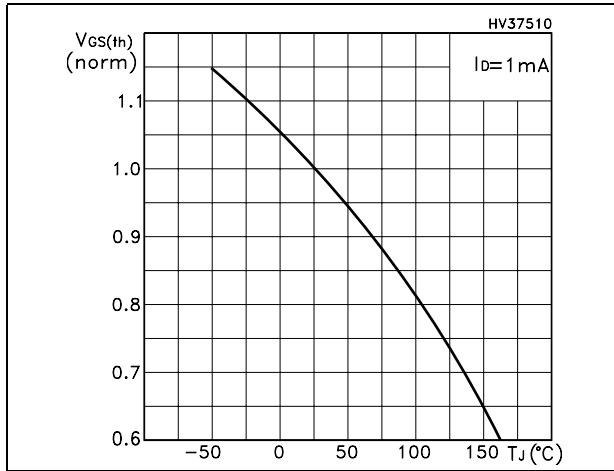

Figure 15. Normalized on resistance vs. temperature

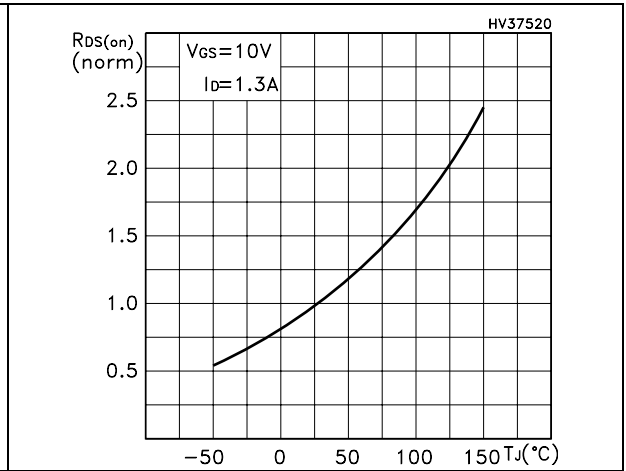

Figure 16. Source-drain diode forward characteristics

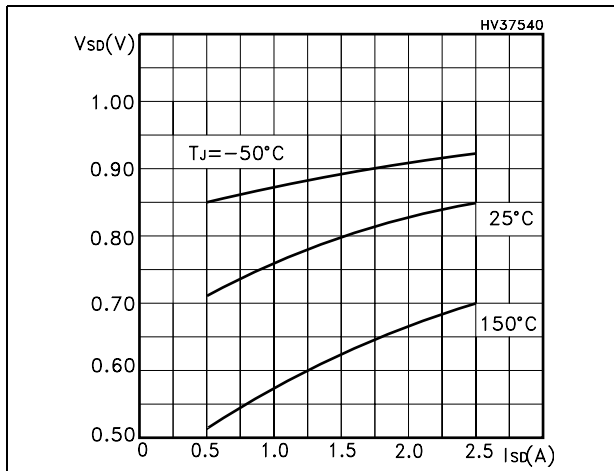
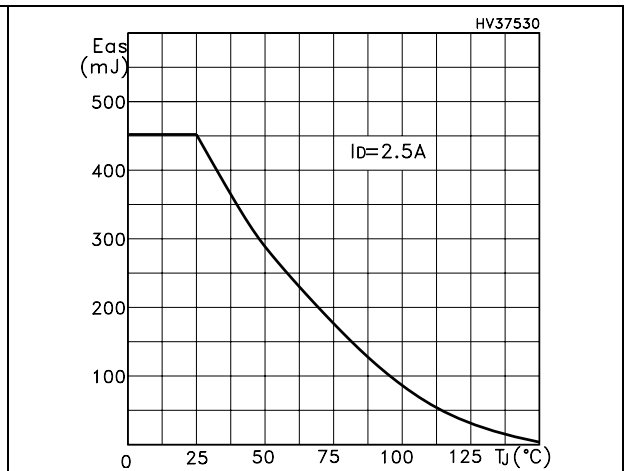
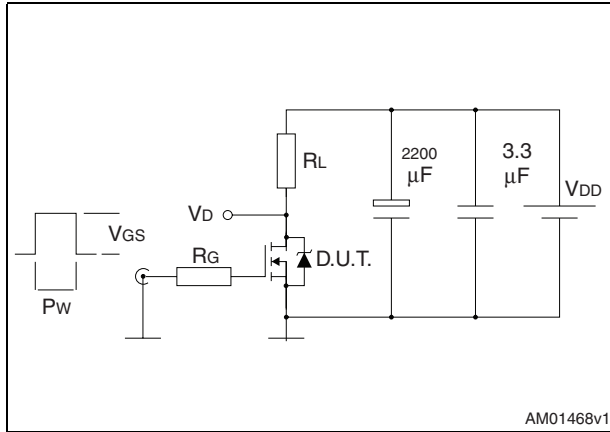

Figure 17. Maximum avalanche energy vs Tj



### 3 Test circuits

**Figure 18. Switching times test circuit for resistive load**



AM01468v1

**Figure 19. Gate charge test circuit**

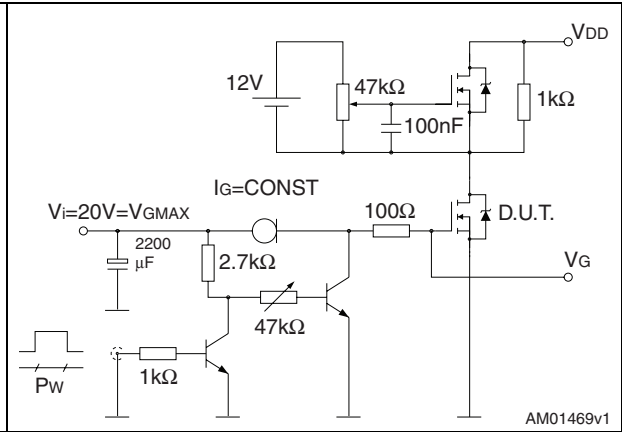

AM01469v1

**Figure 20. Test circuit for inductive load switching and diode recovery times**

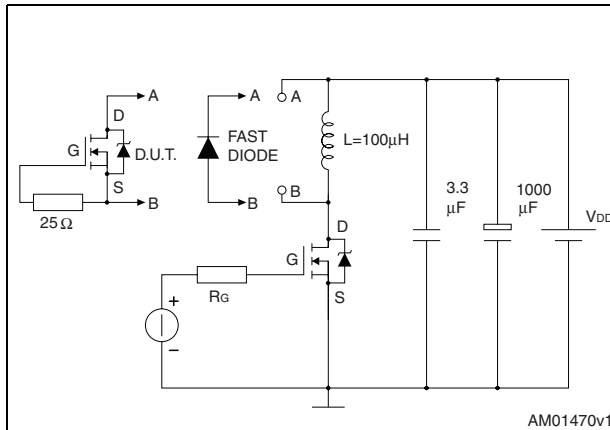

AM01470v1

**Figure 21. Unclamped inductive load test circuit**

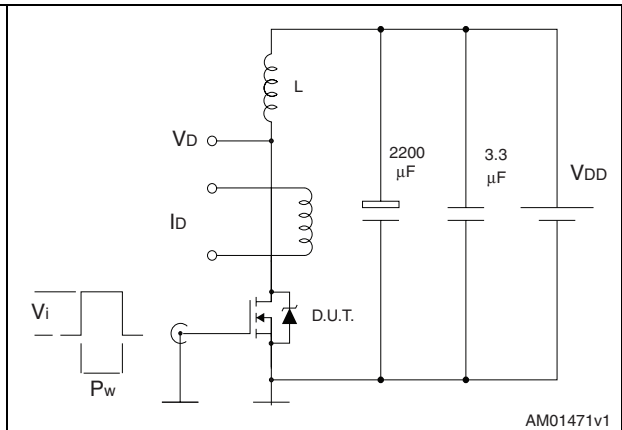

AM01471v1

**Figure 22. Unclamped inductive waveform**

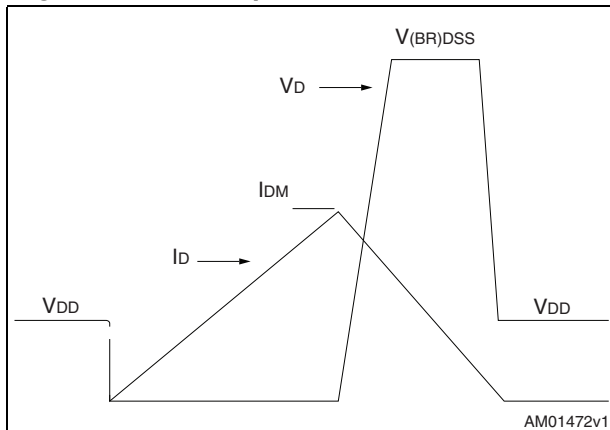

AM01472v1

**Figure 23. Switching time waveform**

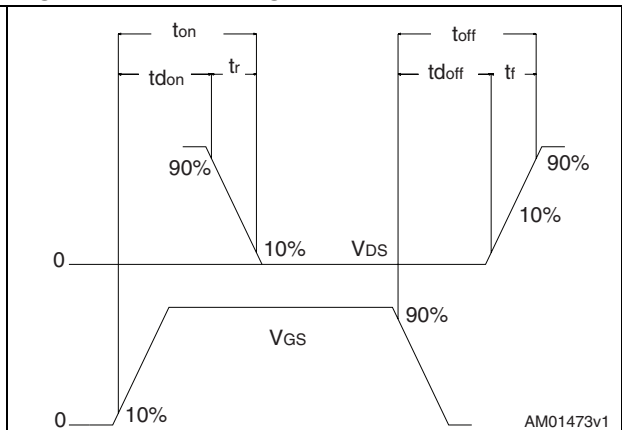

AM01473v1

## 4 Package mechanical data

In order to meet environmental requirements, ST offers these devices in different grades of ECOPACK<sup>®</sup> packages, depending on their level of environmental compliance. ECOPACK<sup>®</sup> specifications, grade definitions and product status are available at: [www.st.com](http://www.st.com). ECOPACK is an ST trademark.

TO-220 mechanical data

Dim	mm			inch		
	Min	Typ	Max	Min	Typ	Max
A	4.40		4.60	0.173		0.181
b	0.61		0.88	0.024		0.034
b1	1.14		1.70	0.044		0.066
c	0.48		0.70	0.019		0.027
D	15.25		15.75	0.6		0.62
D1		1.27			0.050	
E	10		10.40	0.393		0.409
e	2.40		2.70	0.094		0.106
e1	4.95		5.15	0.194		0.202
F	1.23		1.32	0.048		0.051
H1	6.20		6.60	0.244		0.256
J1	2.40		2.72	0.094		0.107
L	13		14	0.511		0.551
L1	3.50		3.93	0.137		0.154
L20		16.40			0.645	
L30		28.90			1.137	
∅P	3.75		3.85	0.147		0.151
Q	2.65		2.95	0.104		0.116

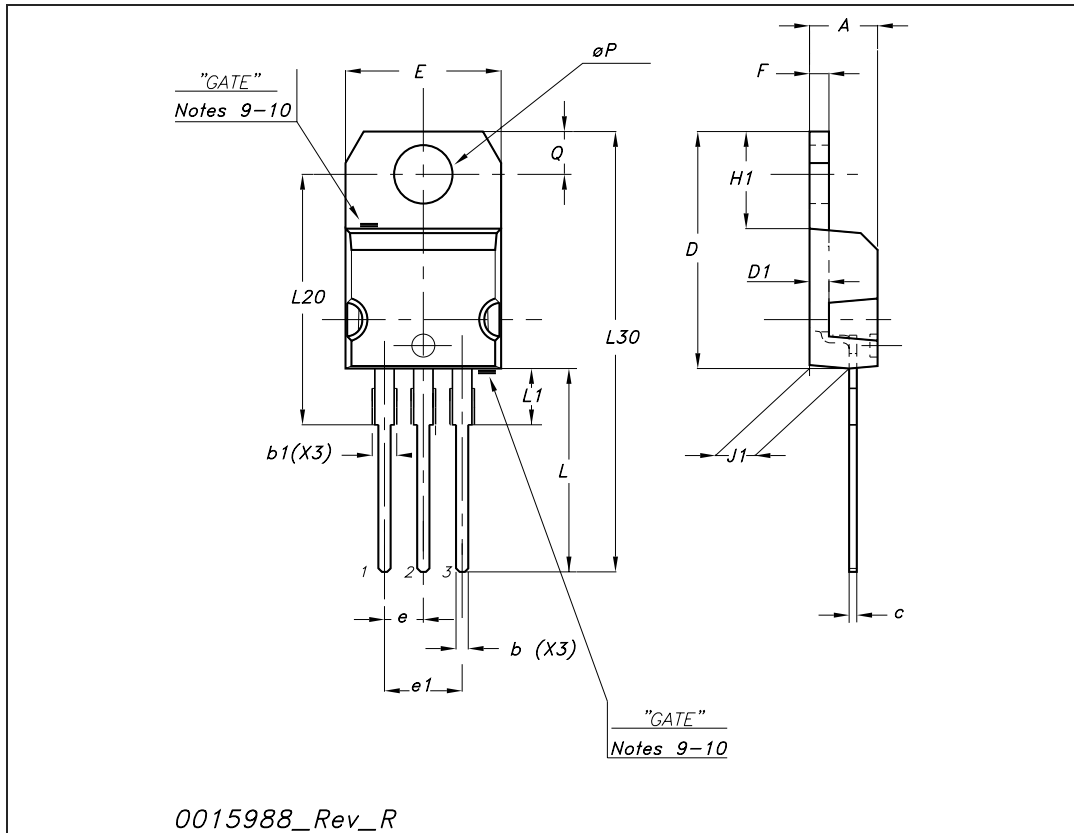

**TO-247 Mechanical data**

Dim.	mm.		
	Min.	Typ	Max.
A	4.85		5.15
A1	2.20		2.60
b	1.0		1.40
b1	2.0		2.40
b2	3.0		3.40
c	0.40		0.80
D	19.85		20.15
E	15.45		15.75
e		5.45	
L	14.20		14.80
L1	3.70		4.30
L2		18.50	
øP	3.55		3.65
øR	4.50		5.50
S		5.50	

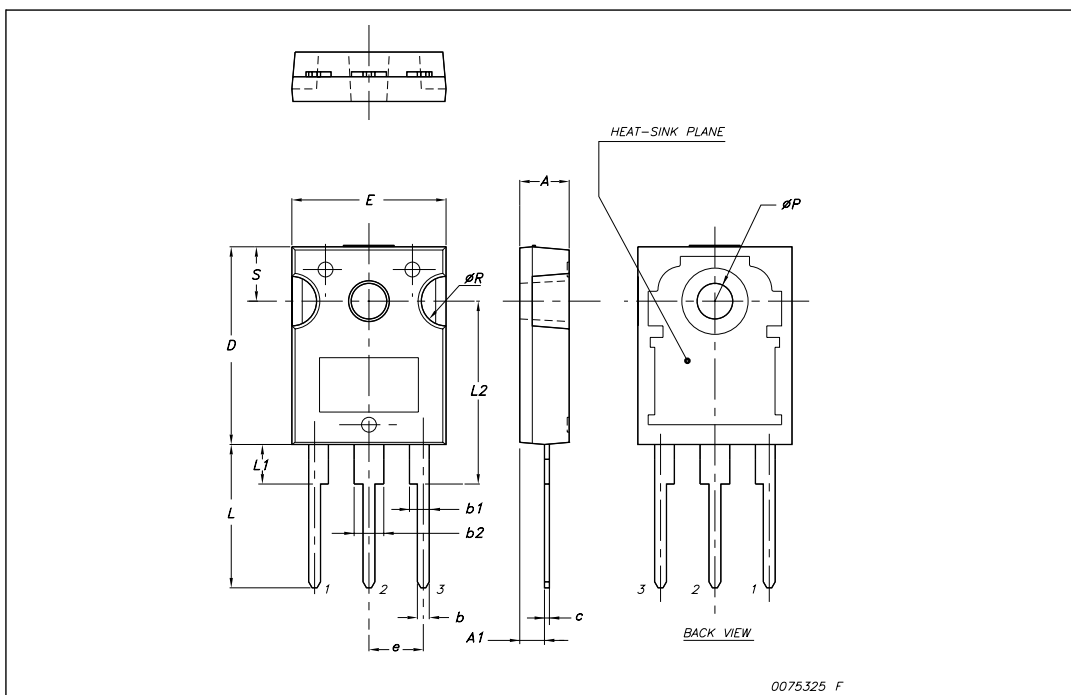

**TO-3PF mechanical data**

DIM.	mm.		
	min.	typ	max.
A	5.30		5.70
C	2.80		3.20
D	3.10		3.50
D1	1.80		2.20
E	0.80		1.10
F	0.65		0.95
F2	1.80		2.20
G	10.30		11.50
G1		5.45	
H	15.30		15.70
L	9.80	10	10.20
L2	22.80		23.20
L3	26.30		26.70
L4	43.20		44.40
L5	4.30		4.70
L6	24.30		24.70
L7	14.60		15
N	1.80		2.20
R	3.80		4.20
Dia	3.40		3.80

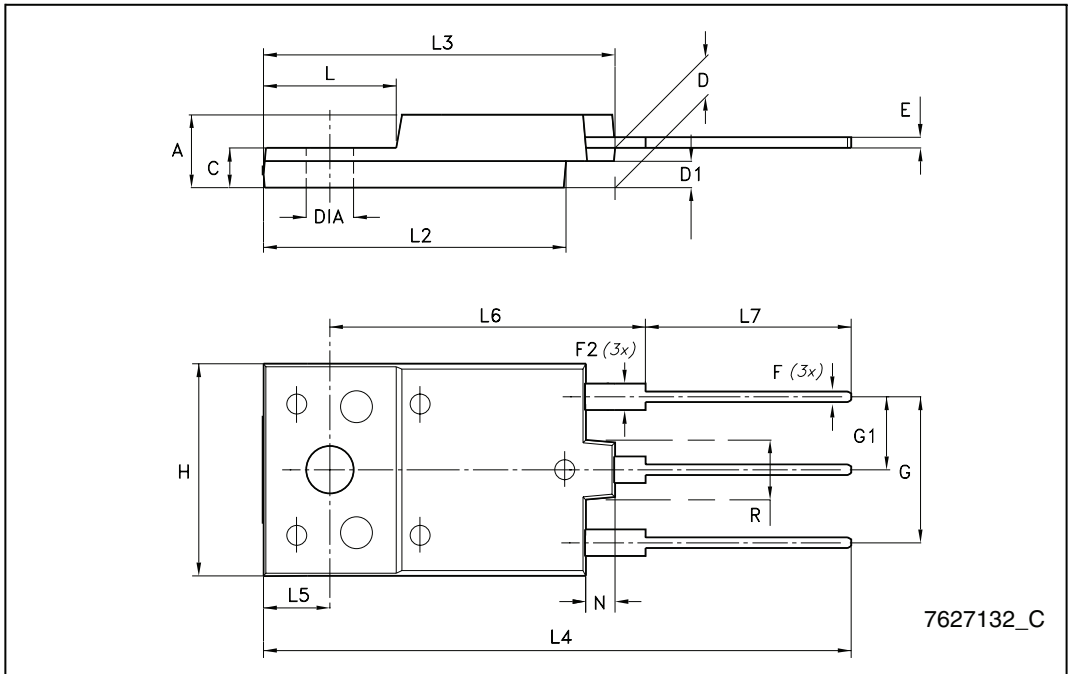

## 5 Revision history

**Table 9. Document revision history**

Date	Revision	Changes
12-Jan-2007	1	First release
17-Apr-2007	2	Added new value on <a href="#">Table 6</a> .
14-May-2007	3	The document has been reformatted
29-Aug-2007	4	$R_{DS(on)}$ value changed, updated <a href="#">Figure 15</a>
09-Apr-2008	5	Added new package: TO-3PF
13-Feb-2009	6	Added $P_{TOT}$ value for TO-3PF ( <a href="#">Table 2: Absolute maximum ratings</a> )
01-Dec-2009	7	– Document status promoted from preliminary data to datasheet – Removed TO-220FH package and mechanical data
10-Dec-2009	8	Corrected $V_{ISO}$ value in <a href="#">Table 2: Absolute maximum ratings</a>
29-Jun-2010	9	Corrected unit in <a href="#">Table 3</a> .

**Please Read Carefully:**

Information in this document is provided solely in connection with ST products. STMicroelectronics NV and its subsidiaries ("ST") reserve the right to make changes, corrections, modifications or improvements, to this document, and the products and services described herein at any time, without notice.

All ST products are sold pursuant to ST's terms and conditions of sale.

Purchasers are solely responsible for the choice, selection and use of the ST products and services described herein, and ST assumes no liability whatsoever relating to the choice, selection or use of the ST products and services described herein.

No license, express or implied, by estoppel or otherwise, to any intellectual property rights is granted under this document. If any part of this document refers to any third party products or services it shall not be deemed a license grant by ST for the use of such third party products or services, or any intellectual property contained therein or considered as a warranty covering the use in any manner whatsoever of such third party products or services or any intellectual property contained therein.

**UNLESS OTHERWISE SET FORTH IN ST'S TERMS AND CONDITIONS OF SALE ST DISCLAIMS ANY EXPRESS OR IMPLIED WARRANTY WITH RESPECT TO THE USE AND/OR SALE OF ST PRODUCTS INCLUDING WITHOUT LIMITATION IMPLIED WARRANTIES OF MERCHANTABILITY, FITNESS FOR A PARTICULAR PURPOSE (AND THEIR EQUIVALENTS UNDER THE LAWS OF ANY JURISDICTION), OR INFRINGEMENT OF ANY PATENT, COPYRIGHT OR OTHER INTELLECTUAL PROPERTY RIGHT.**

**UNLESS EXPRESSLY APPROVED IN WRITING BY AN AUTHORIZED ST REPRESENTATIVE, ST PRODUCTS ARE NOT RECOMMENDED, AUTHORIZED OR WARRANTED FOR USE IN MILITARY, AIR CRAFT, SPACE, LIFE SAVING, OR LIFE SUSTAINING APPLICATIONS, NOR IN PRODUCTS OR SYSTEMS WHERE FAILURE OR MALFUNCTION MAY RESULT IN PERSONAL INJURY, DEATH, OR SEVERE PROPERTY OR ENVIRONMENTAL DAMAGE. ST PRODUCTS WHICH ARE NOT SPECIFIED AS "AUTOMOTIVE GRADE" MAY ONLY BE USED IN AUTOMOTIVE APPLICATIONS AT USER'S OWN RISK.**

Resale of ST products with provisions different from the statements and/or technical features set forth in this document shall immediately void any warranty granted by ST for the ST product or service described herein and shall not create or extend in any manner whatsoever, any liability of ST.

ST and the ST logo are trademarks or registered trademarks of ST in various countries.

Information in this document supersedes and replaces all information previously supplied.

The ST logo is a registered trademark of STMicroelectronics. All other names are the property of their respective owners.

© 2010 STMicroelectronics - All rights reserved

STMicroelectronics group of companies

Australia - Belgium - Brazil - Canada - China - Czech Republic - Finland - France - Germany - Hong Kong - India - Israel - Italy - Japan - Malaysia - Malta - Morocco - Philippines - Singapore - Spain - Sweden - Switzerland - United Kingdom - United States of America

[www.st.com](http://www.st.com)

