

METALLIZED POLYPROPYLENE (OPP), NON-INDUCTIVE, PLASTIC CASE

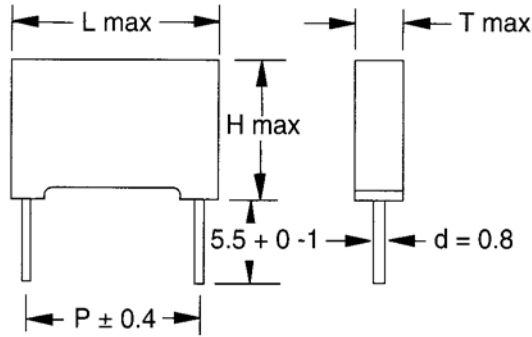

SPECIFICATIONS

Performance Characteristics	
Operating Temperature Range	-40°C ~ +85°C.
Voltage Range	250, 400, & 630VDC.
Withstanding Voltage (between leads)	1.5 times rated voltage for 5 seconds.
Capacitance Range	0.01µF ~ 2.2µF.
Capacitance Tolerance	±1%, ±2%, ±2.5%, ±5%, ±10%, & ±20%.
Maximum Dissipation Factor % (25°C)	0.2 @ 1KHz (typical 0.1). 0.2 @ 10KHz, 0.01µF < C 0.1µF. 0.3 @ 10KHz, 0.1µF < C 1.0µF.
Minimum Insulation Resistance (25°C)	IR ≥ 30000MΩ (C < 0.33µF). IR ≥ 10000MΩ x µF (C ≥ 0.33µF).

MAXIMUM PULSE RISE TIME (DV/DT) V/µSEC

WVDC	P				
	7.5	10.0	15.0	22.5	27.5
160	5.5	4	2	1.5	1
250	15	11	7	4	3
400	35	20	10	5.5	5
630	55	30	15	8	7

PART NUMBERING

Part Number Example: 2124-250/104K10F							
2124	-	250	/	104	K	10	F
Type		Rated DC Voltage		Capacitance Code (pF)*	Tolerance Code	Lead Spacing	RoHs Compliant

* Capacitance Code: First two digits represent significant figures, third digit represents multiplier (number of zeros).

WVDC	160 Case Code	250 Case Code	400 Case Code	630 Case Code
Cap. (µF)				
0.01		B2/C1	C1	C2
0.015		B2/C1	C1	C2
0.022	B2	C1	C2	C3
0.033	B2	C1	C2	D2
0.047	B3	C2	C3	D3
0.068	B3	C2	D2	D4
0.1	C2	C3/D1	D3	E2
0.15	C2	D2	D4	E3
0.22	D1	D2	E2	E4/F1
0.33	D2	E1	E3	F2
0.47	D2	E2	E4/F1	G1
0.68	E2	E2	F1	
1.0	E3	E4/F1	F2	
1.5	E3	F1	G1	
2.2	E4	F2		
3.3	E4			

Case Code	L	T	H	P	dØ
B2	10.5	4.0	9.0	7.5	0.6
B3	10.5	5.0	11.0	7.5	0.6
C1	13.0	4.0	9.0	10.0	0.8
C2	13.0	5.0	11.0	10.0	0.8
C3	13.0	6.0	12.0	10.0	0.8
D1	18.0	5.0	11.0	15.0	0.8
D2	18.0	6.0	12.0	15.0	0.8
D3	18.0	7.5	13.5	15.0	0.8
D4	18.0	8.5	14.5	15.0	0.8
E1	26.5	6.0	15.0	22.5	0.8
E2	26.5	7.0	16.5	22.5	0.8
E3	26.5	8.5	17.0	22.5	0.8
E4	26.5	10.0	19.0	22.5	0.8
F1	32.0	11.0	20.0	27.5	0.8
F2	32.0	13.0	22.0	27.5	0.8
G1	32.0	15.0	30.0	27.5	0.8

Please state required case code when submitting inquiries.