



STS4DNFS30L

N-channel 30 V, 0.044 Ω , 4 A SO-8
STripFET™ MOSFET plus SCHOTTKY rectifier

Features

MOSFET	V_{DSS}	R_{DS(on)}	I_D
	30V	<0.056 Ω	4A
SCHOTTKY	I_{F(AV)}	V_{RRM}	V_{F(MAX)}
	3A	30V	0.51V

- Standard outline for easy automated surface mount assembly
- Low threshold gate drive
- Integrated SCHOTTKY rectifier

Applications

- Switching applications

Description

This device is an N-channel Power MOSFET. It associates the latest low voltage STripFET™ in N-channel version to a low drop Schottky diode. Such configuration is extremely versatile in implementing, a large variety of DC-DC converters for printers, portable equipment, and cellular phones.

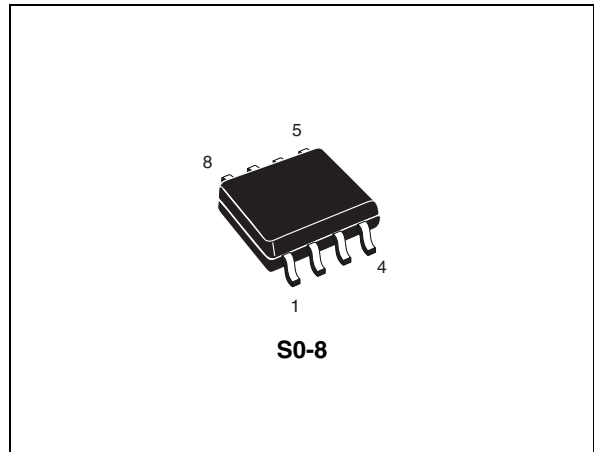

Figure 1. Internal schematic diagram

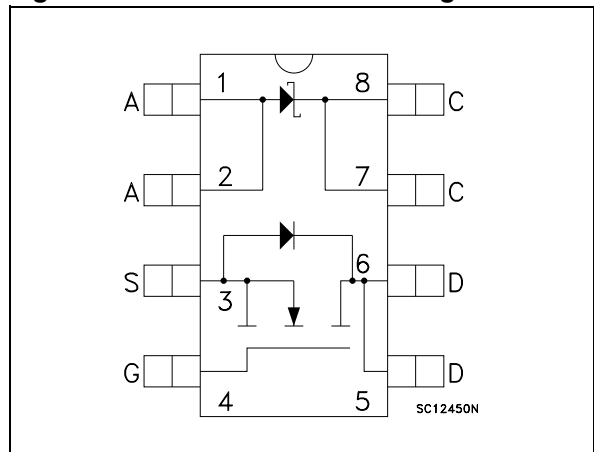

Table 1. Device summary

Order code	Marking	Package	Packaging
STS4DNFS30L	4DFS30L	SO-8	Tape and reel

Contents

1	Electrical ratings	3
2	Electrical characteristics	4
	2.1 Electrical characteristics (curves)	6
3	Test circuit	8
4	Package mechanical data	9
5	Revision history	12

1 Electrical ratings

Table 2. Absolute maximum ratings

Symbol	Parameter	Value	Unit
V_{DS}	Drain-source voltage ($v_{GS} = 0$)	30	V
V_{DGR}	Drain-gate voltage ($R_{GS} = 20 \text{ k}\Omega$)	30	V
V_{GS}	Gate- source voltage	± 16	V
I_D	Drain current (continuous) at $T_C = 25^\circ\text{C}$	4	A
I_D	Drain current (continuous) at $T_C = 100^\circ\text{C}$	2.5	A
$I_{DM}^{(1)}$	Drain current (pulsed)	16	A
P_{TOT}	Total dissipation at $T_C = 25^\circ\text{C}$ dual operation	2	W

1. Pulse width limited by safe operating area.

Table 3. Schottky absolute maximum ratings

Symbol	Parameter		Value	Unit
V_{RRM}	Repetitive peak reverse voltage		30	V
$I_{F(RMS)}$	RMS forward current		20	A
$I_{F(AV)}$	Average forward current	$T_L = 125^\circ\text{C}$ $\delta = 0.5$	3	A
I_{FSM}	Surge non repetitive forward current	$t_p = 10 \text{ ms}$ Sinusoidal	75	A
I_{RRM}	Repetitive peak reverse current	$t_p = 2 \mu\text{s}$ $F = 1 \text{ kHz}$	1	A
I_{RSM}	Non repetitive peak reverse current	$t_p = 100 \mu\text{s}$	1	A
dv/dt	Critical rate of rise of reverse voltage		10000	$\text{V}/\mu\text{s}$

Table 4. Thermal data

Symbol	Parameter	Value	Unit
R_{thj-a}	Thermal resistance junction-ambient MOSFET ⁽¹⁾	62.5	$^\circ\text{C}/\text{W}$ $^\circ\text{C}/\text{W}$
T_J	Junction temperature	-55 to 150	$^\circ\text{C}$
T_{stg}	Storage temperature range	-55 to 150	$^\circ\text{C}$

1. Mounted on FR-4 board (steady state).

2 Electrical characteristics

($T_{CASE}=25^{\circ}C$ unless otherwise specified).

Table 5. On/off states

Symbol	Parameter	Test conditions	Min.	Typ.	Max.	Unit
$V_{(BR)DSS}$	Drain-source Breakdown voltage	$I_D = 250 \mu A, V_{GS} = 0$	30			V
I_{DSS}	Zero gate voltage	$V_{DS} = \text{Max rating}$			1	μA
	Drain current ($V_{GS} = 0$)	$V_{DS} = \text{Max rating},$ $T_C = 125^{\circ}C$			10	μA
I_{GSS}	Gate-body leakage current ($V_{DS} = 0$)	$V_{GS} = \pm 16V$			± 100	nA
$V_{GS(th)}$	Gate threshold voltage	$V_{DS} = V_{GS}, I_D = 250\mu A$	1			V
$R_{DS(on)}$	Static drain-source on resistance	$V_{GS} = 10V, I_D = 2A$		0.044	0.055	Ω
		$V_{GS} = 5V, I_D = 2A$		0.051	0.065	Ω

Table 6. Dynamic

Symbol	Parameter	Test conditions	Min.	Typ.	Max.	Unit
$g_{fs}^{(1)}$	Forward transconductance	$V_{DS} = 15V, I_D = 2A$		5		S
C_{iss}	Input capacitance	$V_{DS} = 25V, f = 1 \text{ MHz},$ $V_{GS} = 0$		330		pF
C_{oss}	Output capacitance			90		pF
C_{rss}	Reverse transfer capacitance			40		pF
Q_g	Total gate charge	$V_{DD} = 24V, I_D = 4A,$ $V_{GS} = 5V$		6.5	9	nC
Q_{gs}	Gate-source charge			3.6		nC
Q_{gd}	Gate-drain charge			2		nC

1. Pulsed: Pulse duration = 300 μs , duty cycle 1.5.

Table 7. Switching times

Symbol	Parameter	Test conditions	Min.	Typ.	Max.	Unit
$t_{d(on)}$ t_r	Turn-on delay time	$V_{DD} = 15V, I_D = 2A,$ $R_G = 4.7\Omega, V_{GS} = 5V$ (see Figure 13)		11		ns
	Rise time			100		ns
$t_{d(off)}$ t_f	Turn-off delay time	$V_{DD} = 15V, I_D = 2A,$ $R_G = 4.7\Omega, V_{GS} = 5V$ (see Figure 13)		25		ns
	Fall time			22		ns

Table 8. Source drain diode

Symbol	Parameter	Test conditions	Min	Typ.	Max	Unit
I_{SD}	Source-drain current				4	A
$I_{SDM}^{(1)}$	Source-drain current (pulsed)				16	A
$V_{SD}^{(2)}$	Forward on voltage	$I_{SD} = 4A, V_{GS} = 0$			1.2	V
t_{rr}	Reverse recovery time	$I_{SD} = 4A, V_{DD} = 15V$ $di/dt = 100A/\mu s,$ $T_j = 150^\circ C$ (see Figure 15)		35		ns
Q_{rr}	Reverse recovery charge			25		nC
I_{RRM}	Reverse recovery current			1.4		A

1. Pulse width limited by safe operating area.
2. Pulsed: Pulse duration = 300 μs , duty cycle 1.5%

2.1 Electrical characteristics (curves)

Figure 2. Safe operating area

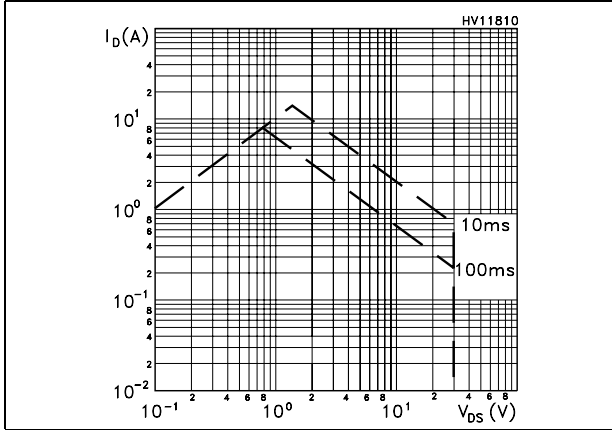

Figure 3. Thermal impedance

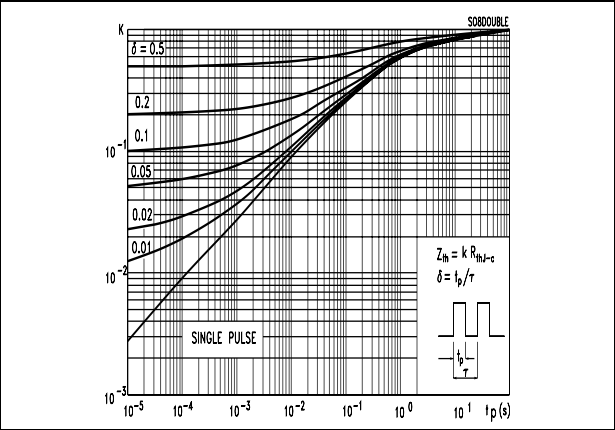

Figure 4. Output characteristics

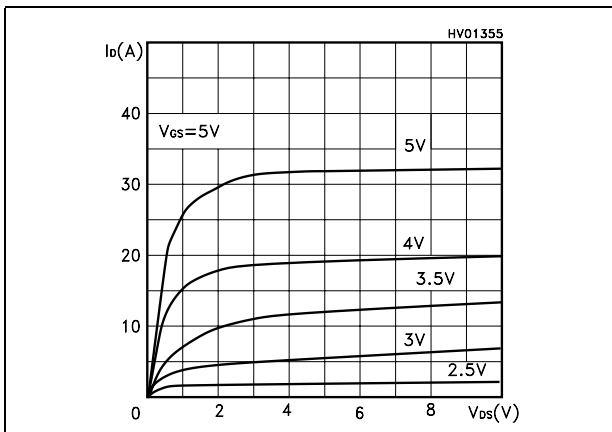

Figure 5. Transfer characteristics

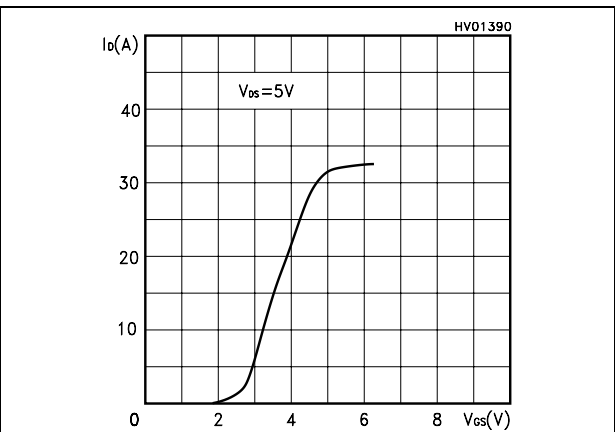

Figure 6. Transconductance

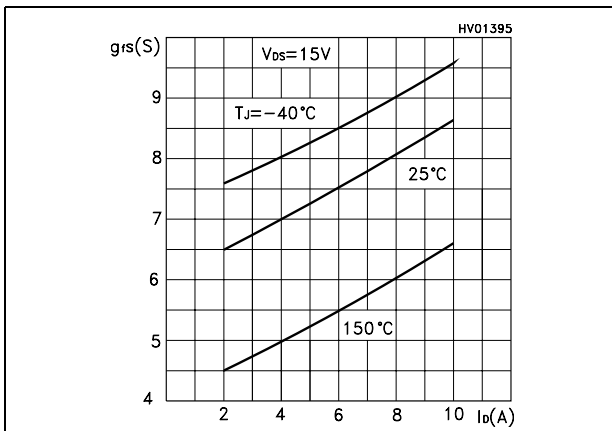

Figure 7. Static drain-source on resistance

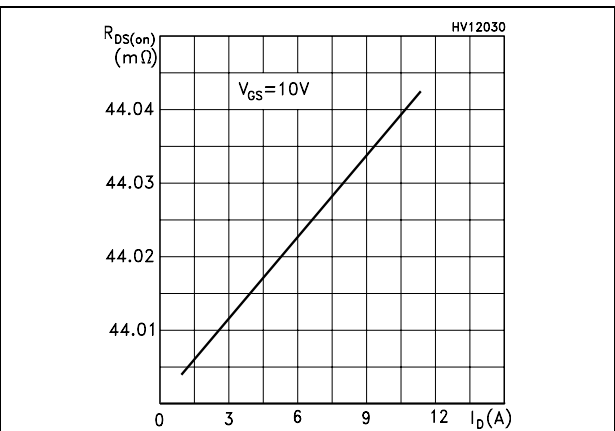

Figure 8. Gate charge vs. gate-source voltage Figure 9. Capacitance variations

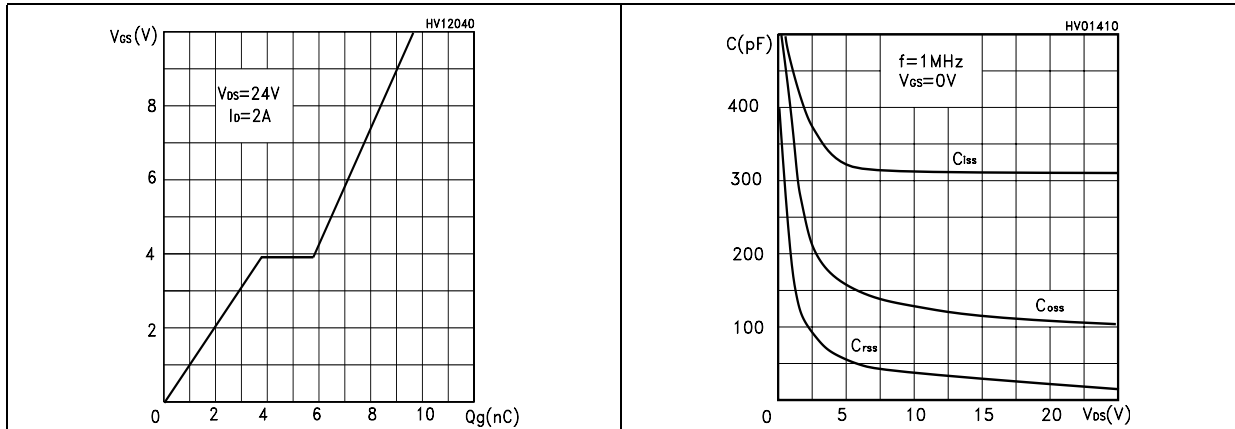

Figure 10. Normalized gate threshold voltage vs. temperature

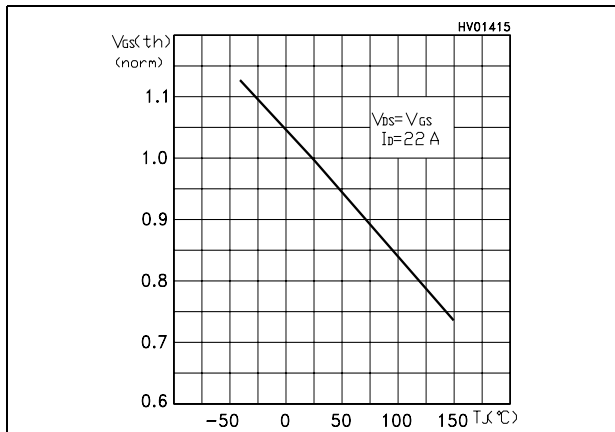

Figure 11. Normalized on resistance vs. temperature

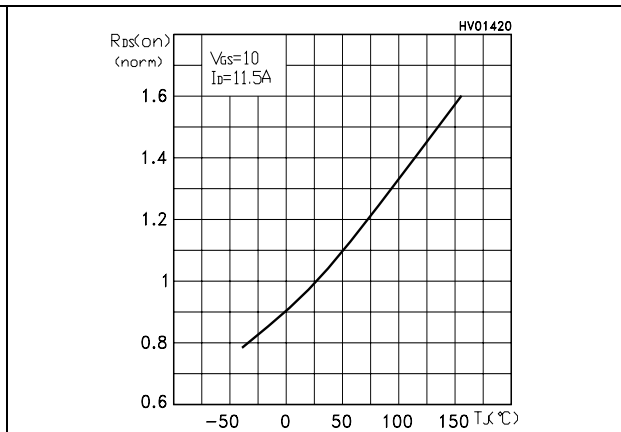
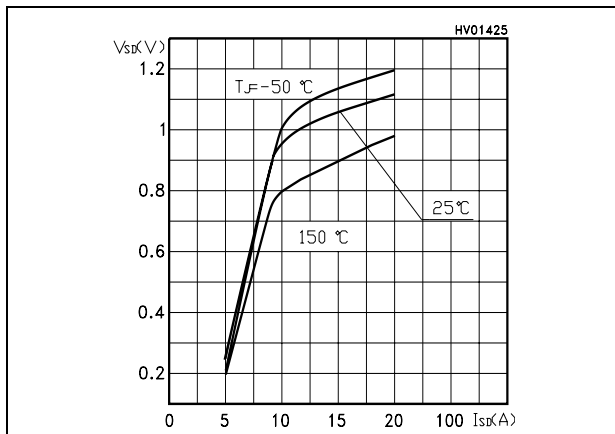

Figure 12. Source-drain diode forward characteristics



3 Test circuit

Figure 13. Switching times test circuit for resistive load

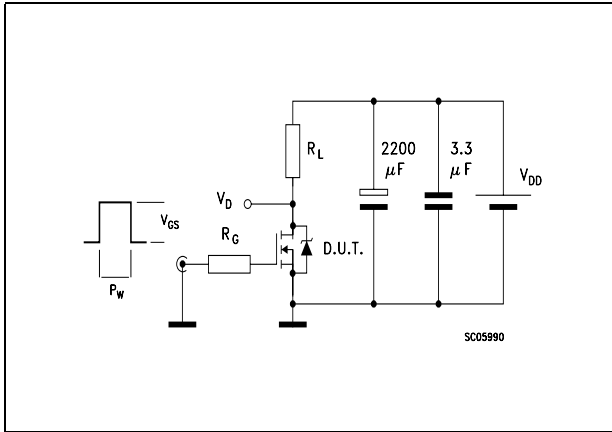

Figure 14. Gate charge test circuit

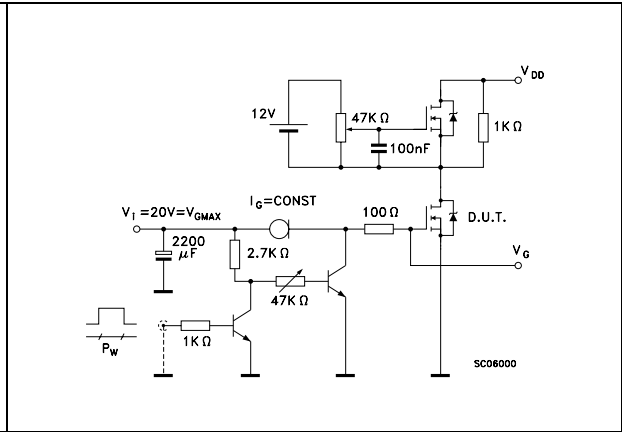

Figure 15. Test circuit for inductive load switching and diode recovery times

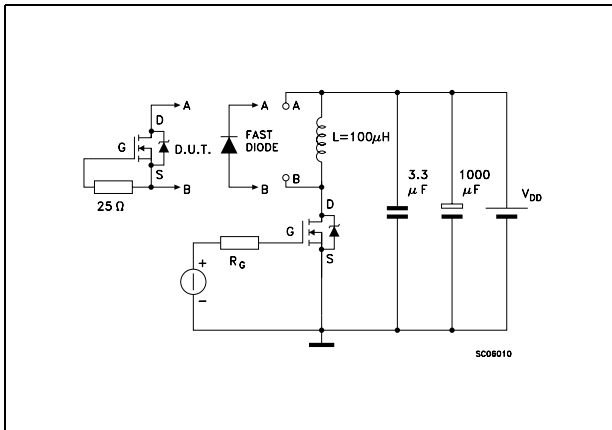

Figure 16. Unclamped Inductive load test circuit

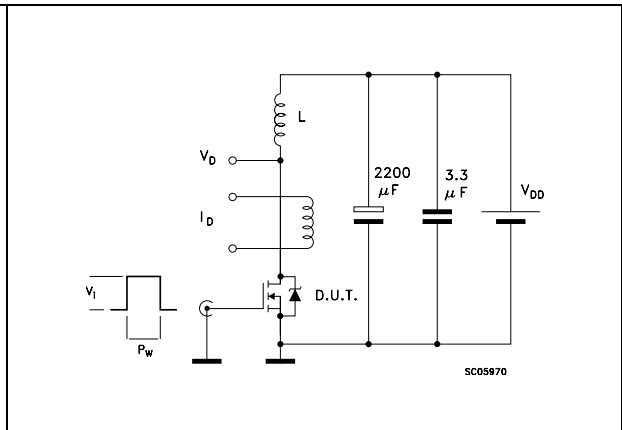

Figure 17. Unclamped inductive waveform

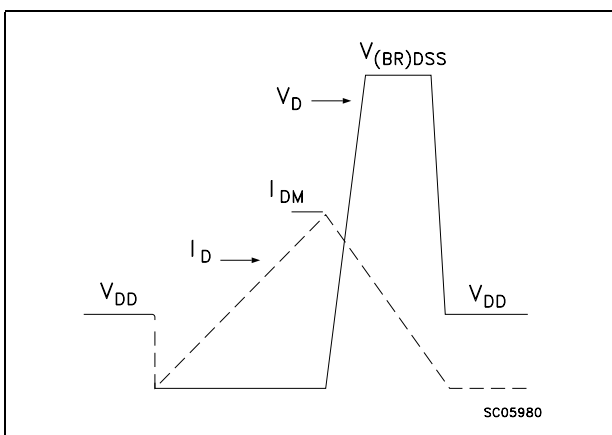
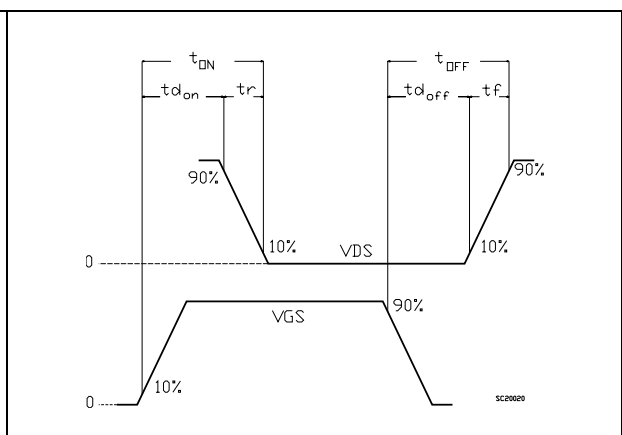

Figure 18. Switching time waveform



4 Package mechanical data

In order to meet environmental requirements, ST offers these devices in different grades of ECOPACK® packages, depending on their level of environmental compliance. ECOPACK® specifications, grade definitions and product status are available at: www.st.com. ECOPACK is an ST trademark.

Table 9. SO-8 mechanical data

Dim.	mm		
	Min.	Typ.	Max.
A			1.75
A1	0.10		0.25
A2	1.25		
b	0.28		0.48
c	0.17		0.23
D	4.80	4.90	5.00
E	5.80	6.00	6.20
E1	3.80	3.90	4.00
e		1.27	
h	0.25		0.50
L	0.40		1.27
L1		1.04	
k	0°		8°
ccc			0.10

Figure 19. SO-8 drawing

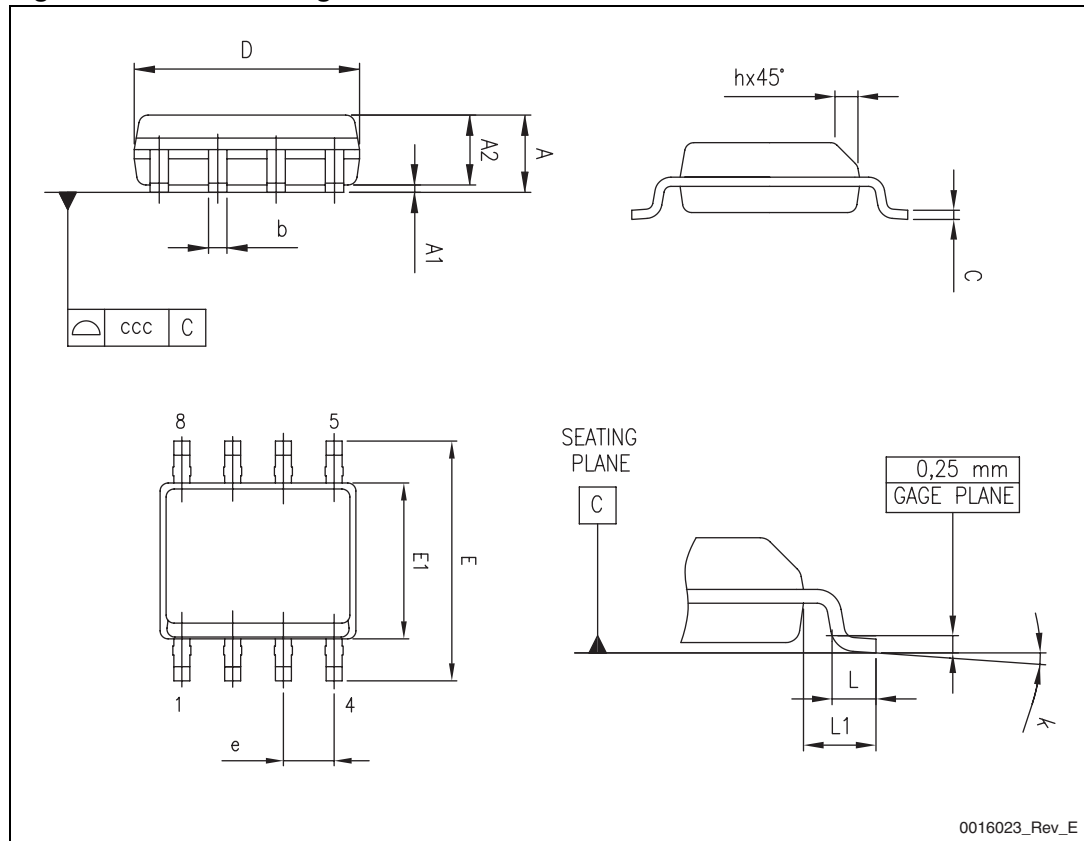

5 Revision history

Table 10. Document revision history

Date	Revision	Changes
21-Jun-2004	2	Complete version
10-Nov-2006	3	The document has been reformatted
26-Jan-2007	4	Typo mistakes on Table 2 .
29-Jun-2011	5	Modified marking in Table 1 . Updated mechanical data.

Please Read Carefully:

Information in this document is provided solely in connection with ST products. STMicroelectronics NV and its subsidiaries ("ST") reserve the right to make changes, corrections, modifications or improvements, to this document, and the products and services described herein at any time, without notice.

All ST products are sold pursuant to ST's terms and conditions of sale.

Purchasers are solely responsible for the choice, selection and use of the ST products and services described herein, and ST assumes no liability whatsoever relating to the choice, selection or use of the ST products and services described herein.

No license, express or implied, by estoppel or otherwise, to any intellectual property rights is granted under this document. If any part of this document refers to any third party products or services it shall not be deemed a license grant by ST for the use of such third party products or services, or any intellectual property contained therein or considered as a warranty covering the use in any manner whatsoever of such third party products or services or any intellectual property contained therein.

UNLESS OTHERWISE SET FORTH IN ST'S TERMS AND CONDITIONS OF SALE ST DISCLAIMS ANY EXPRESS OR IMPLIED WARRANTY WITH RESPECT TO THE USE AND/OR SALE OF ST PRODUCTS INCLUDING WITHOUT LIMITATION IMPLIED WARRANTIES OF MERCHANTABILITY, FITNESS FOR A PARTICULAR PURPOSE (AND THEIR EQUIVALENTS UNDER THE LAWS OF ANY JURISDICTION), OR INFRINGEMENT OF ANY PATENT, COPYRIGHT OR OTHER INTELLECTUAL PROPERTY RIGHT.

UNLESS EXPRESSLY APPROVED IN WRITING BY AN AUTHORIZED ST REPRESENTATIVE, ST PRODUCTS ARE NOT RECOMMENDED, AUTHORIZED OR WARRANTED FOR USE IN MILITARY, AIR CRAFT, SPACE, LIFE SAVING, OR LIFE SUSTAINING APPLICATIONS, NOR IN PRODUCTS OR SYSTEMS WHERE FAILURE OR MALFUNCTION MAY RESULT IN PERSONAL INJURY, DEATH, OR SEVERE PROPERTY OR ENVIRONMENTAL DAMAGE. ST PRODUCTS WHICH ARE NOT SPECIFIED AS "AUTOMOTIVE GRADE" MAY ONLY BE USED IN AUTOMOTIVE APPLICATIONS AT USER'S OWN RISK.

Resale of ST products with provisions different from the statements and/or technical features set forth in this document shall immediately void any warranty granted by ST for the ST product or service described herein and shall not create or extend in any manner whatsoever, any liability of ST.

ST and the ST logo are trademarks or registered trademarks of ST in various countries.

Information in this document supersedes and replaces all information previously supplied.

The ST logo is a registered trademark of STMicroelectronics. All other names are the property of their respective owners.

© 2011 STMicroelectronics - All rights reserved

STMicroelectronics group of companies

Australia - Belgium - Brazil - Canada - China - Czech Republic - Finland - France - Germany - Hong Kong - India - Israel - Italy - Japan - Malaysia - Malta - Morocco - Philippines - Singapore - Spain - Sweden - Switzerland - United Kingdom - United States of America

www.st.com