



MJE2955T
MJE3055T

COMPLEMENTARY SILICON POWER TRANSISTORS

- STMicroelectronics PREFERRED SALESTYPES
- COMPLEMENTARY PNP - NPN DEVICES

DESCRIPTION

The MJE3055T is a silicon Epitaxial-Base NPN transistor in Jedec TO-220 package. It is intended for power switching circuits and general-purpose amplifiers. The complementary PNP type is MJE2955T.

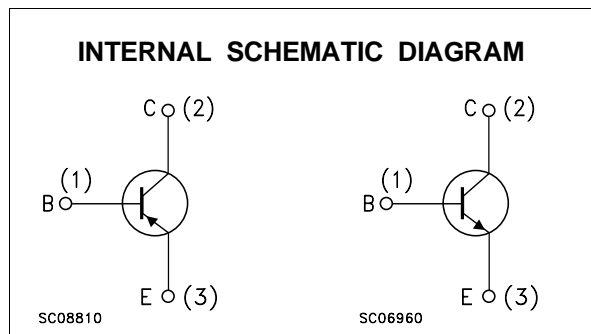
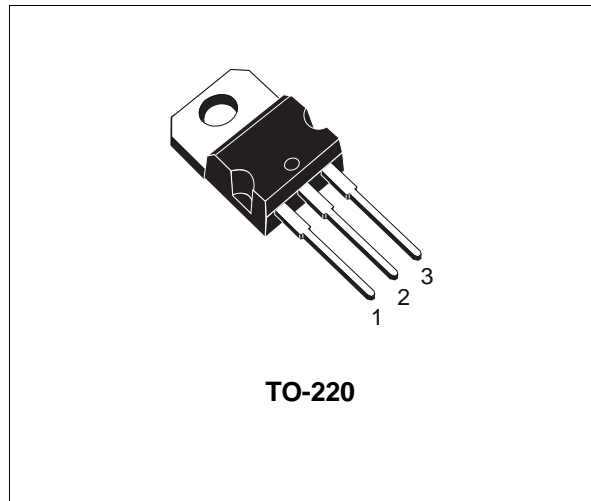

ABSOLUTE MAXIMUM RATINGS

Symbol	Parameter	Value		Unit
		NPN	MJE3055T	
		PNP	MJE2955T	
V_{CEO}	Collector-Emitter Voltage ($I_B = 0$)		60	V
V_{CBO}	Collector-Base Voltage ($I_E = 0$)		70	V
V_{EBO}	Emitter-Base Voltage ($I_C = 0$)		5	V
I_C	Collector Current		10	A
I_B	Base Current		6	A
P_{tot}	Total Power Dissipation at $T_{case} \leq 25\text{ }^\circ\text{C}$		75	W
T_{stg}	Storage Temperature		-55 to 150	$^\circ\text{C}$
T_j	Max. Operating Junction Temperature		150	$^\circ\text{C}$

For PNP types voltage and current values are negative.

MJE2955T / MJE3055T

THERMAL DATA

R _{thj-case}	Thermal Resistance Junction-case	Max	1.66	°C/W
-----------------------	----------------------------------	-----	------	------

ELECTRICAL CHARACTERISTICS (T_{case} = 25 °C unless otherwise specified)

Symbol	Parameter	Test Conditions		Min.	Typ.	Max.	Unit
I _{CEO}	Collector Cut-off Current (I _B = 0)	V _{CE} = 30 V				700	μA
I _{CEX}	Collector Cut-off Current (V _{BE} = 1.5V)	V _{CE} = 70 V T _{case} = 150°C				1 5	mA mA
I _{CBO}	Collector Cut-off Current (I _E = 0)	V _{CB0} = 70 V T _{case} = 150°C				1 10	mA mA
I _{EBO}	Emitter Cut-off Current (I _C = 0)	V _{EBO} = 5 V				5	mA
V _{CEO(sus)} *	Collector-Emitter Sustaining Voltage (I _B = 0)	I _C = 200 mA		60			V
V _{CE(sat)} *	Collector-Emitter Sustaining Voltage	I _C = 4 A I _C = 10 A	I _B = 0.4 A I _B = 3.3 A			1.1 8	V V
V _{BE(on)} *	Base-Emitter on Voltage	I _C = 4 A	V _{CE} = 4 V			1.8	V
h _{FE}	DC Current Gain	I _C = 4 A I _C = 10 A	V _{CE} = 4 V V _{CE} = 4 V	20 5		70	
f _T	Transistor Frequency	I _C = 500 mA f = 500 KHz	V _{CE} = 10 V	2			MHz

* Pulsed: Pulse duration = 300μs, duty cycle ≤ 2 %
For PNP type voltage and current values are negative.

TO-220 MECHANICAL DATA

DIM.	mm			inch		
	MIN.	TYP.	MAX.	MIN.	TYP.	MAX.
A	4.40		4.60	0.173		0.181
C	1.23		1.32	0.048		0.052
D	2.40		2.72	0.094		0.107
E	0.49		0.70	0.019		0.027
F	0.61		0.88	0.024		0.034
F1	1.14		1.70	0.044		0.067
F2	1.14		1.70	0.044		0.067
G	4.95		5.15	0.194		0.202
G1	2.40		2.70	0.094		0.106
H2	10.00		10.40	0.394		0.409
L2		16.40			0.645	
L4	13.00		14.00	0.511		0.551
L5	2.65		2.95	0.104		0.116
L6	15.25		15.75	0.600		0.620
L7	6.20		6.60	0.244		0.260
L9	3.50		3.93	0.137		0.154
M		2.60			0.102	
DIA.	3.75		3.85	0.147		0.151

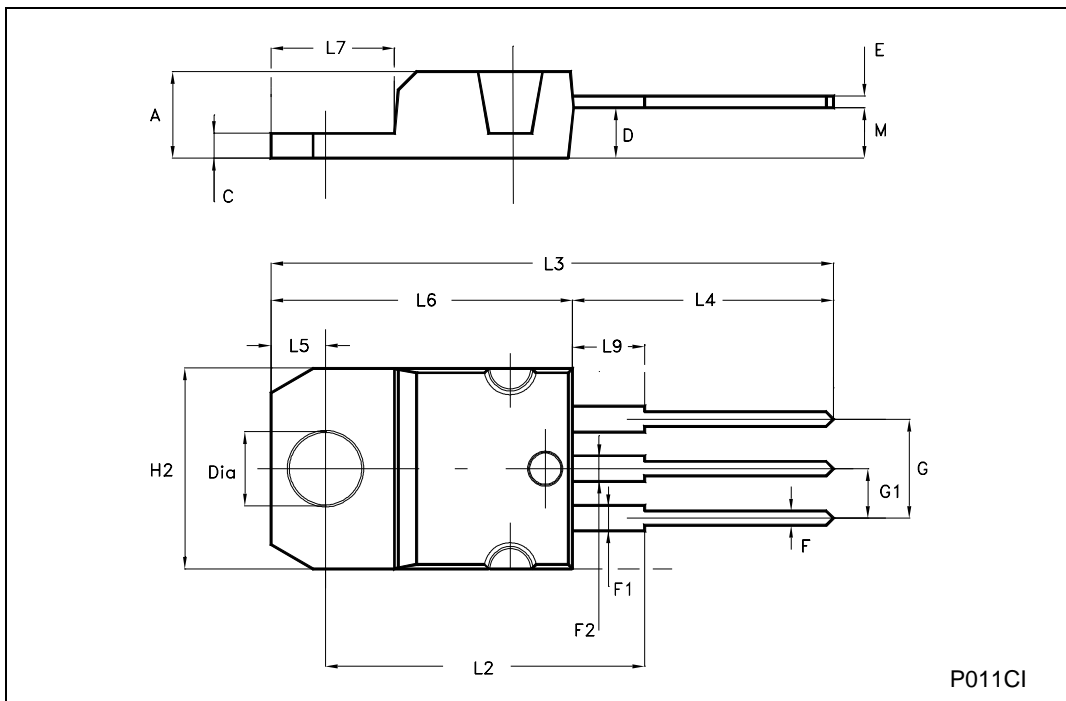

Information furnished is believed to be accurate and reliable. However, STMicroelectronics assumes no responsibility for the consequences of use of such information nor for any infringement of patents or other rights of third parties which may result from its use. No license is granted by implication or otherwise under any patent or patent rights of STMicroelectronics. Specification mentioned in this publication are subject to change without notice. This publication supersedes and replaces all information previously supplied. STMicroelectronics products are not authorized for use as critical components in life support devices or systems without express written approval of STMicroelectronics.

The ST logo is a trademark of STMicroelectronics.

All other names are the property of their respective owners.

© 2003 STMicroelectronics – All Rights reserved

STMicroelectronics GROUP OF COMPANIES

Australia - Belgium - Brazil - Canada - China - Czech Republic - Finland - France - Germany - Hong Kong - India - Israel - Italy - Japan - Malaysia - Malta - Morocco - Singapore - Spain - Sweden - Switzerland - United Kingdom - United States.

<http://www.st.com>