



COMPLEMENTARY SILICON POWER TRANSISTORS

- STMicroelectronics PREFERRED SALESTYPES
- COMPLEMENTARY PNP - NPN DEVICES
- MEDIUM VOLTAGE CAPABILITY
- SURFACE-MOUNTING TO-252 (DPAK) POWER PACKAGE IN TAPE & REEL (SUFFIX "T4")
- ELECTRICAL SIMILAR TO MJE340 AND MJE350

APPLICATIONS

- SOLENOID/RELAY DRIVERS
- GENERAL PURPOSE SWITCHING AND AMPLIFIER

DESCRIPTION

The MJD340 and MJD350 form complementary NPN - PNP pairs.

They are manufactured using Medium Voltage Epitaxial-Planar technology, resulting in a rugged high performance cost-effective transistor.

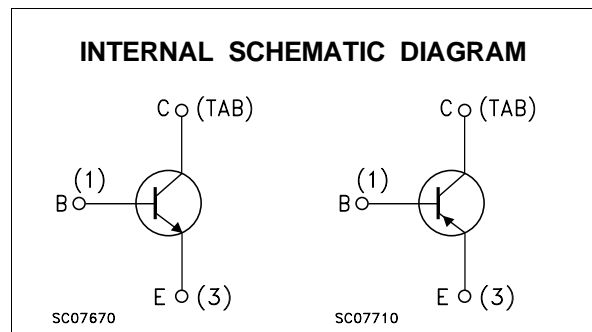
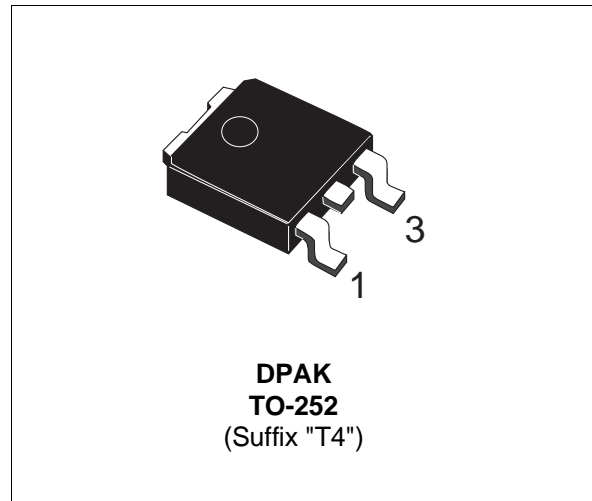

ABSOLUTE MAXIMUM RATINGS

Symbol	Parameter	Value		Unit	
		NPN	MJD340		
V_{CBO}	Collector-Base Voltage ($I_E = 0$)	PNP	MJD350	300	V
V_{CEO}	Collector-Emitter Voltage ($I_B = 0$)			300	V
V_{EBO}	Emitter-Base Voltage ($I_C = 0$)			3	V
I_C	Collector Current			0.5	A
I_{CM}	Collector Peak Current ($t_p = 25\text{ }^\circ\text{C}$)			0.75	A
P_{tot}	Total Power Dissipation at $T_{case} \leq 25\text{ }^\circ\text{C}$			15	W
T_{stg}	Storage Temperature			-65 to 150	$^\circ\text{C}$
T_j	Max Operating Junction Temperature			150	$^\circ\text{C}$

For PNP types voltage and current values are negative.

MJD340 / MJD350

THERMAL DATA

R _{thj-case}	Thermal Resistance Junction-case	Max	8.33	°C/W
R _{thj-amb}	Thermal Resistance Junction-ambient	Max	100	°C/W

ELECTRICAL CHARACTERISTICS (T_{case} = 25 °C unless otherwise specified)

Symbol	Parameter	Test Conditions	Min.	Typ.	Max.	Unit
I _{CBO}	Collector Cut-off Current (V _{BE} = 0)	V _{CB} = 300 V			0.1	mA
I _{EBO}	Emitter Cut-off Current (I _C = 0)	V _{EB} = 3 V			0.1	mA
V _{CEO(sus)*}	Collector-Emitter Sustaining Voltage (I _B = 0)	I _C = 1 mA	300			V
h _{FE*}	DC Current Gain	I _C = 50 mA V _{CE} = 10 V	30		240	

* Pulsed: Pulse duration = 300 μs, duty cycle ≤ 2 %
 For PNP type voltage and current values are negative.

Safe Operating Area

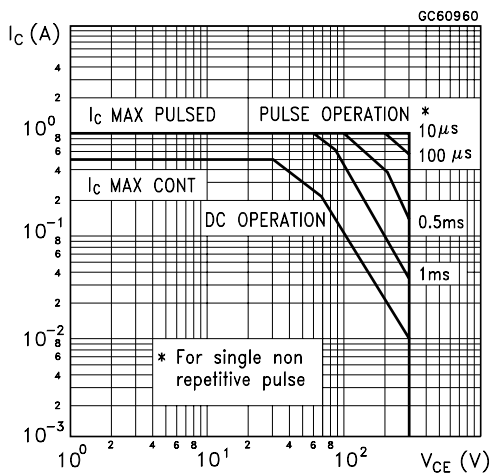

Derating Curve

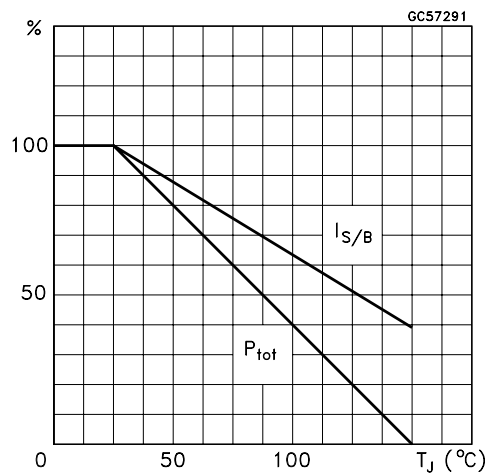

DC Current Gain (NPN type)

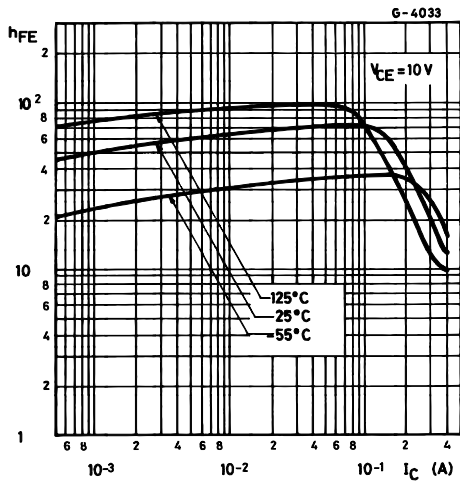

DC Current Gain (PNP type)

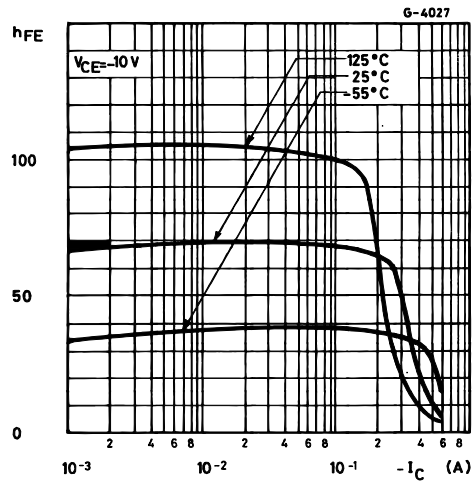

Collector Emitter Saturation Voltage (NPN type)

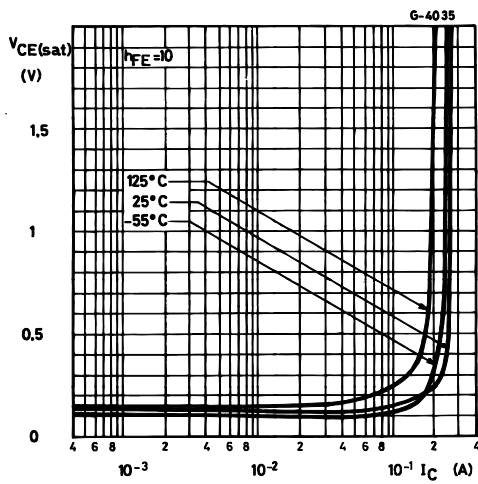

Collector Emitter Saturation Voltage (PNP type)

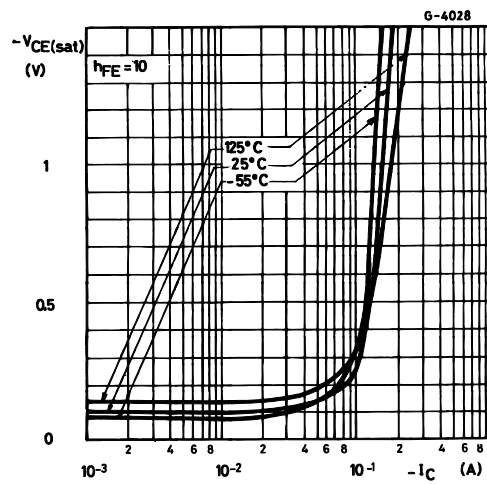

TO-252 (DPAK) MECHANICAL DATA

DIM.	mm			inch		
	MIN.	TYP.	MAX.	MIN.	TYP.	MAX.
A	2.20		2.40	0.087		0.094
A1	0.90		1.10	0.035		0.043
A2	0.03		0.23	0.001		0.009
B	0.64		0.90	0.025		0.035
B2	5.20		5.40	0.204		0.213
C	0.45		0.60	0.018		0.024
C2	0.48		0.60	0.019		0.024
D	6.00		6.20	0.236		0.244
E	6.40		6.60	0.252		0.260
G	4.40		4.60	0.173		0.181
H	9.35		10.10	0.368		0.398
L2		0.8			0.031	
L4	0.60		1.00	0.024		0.039
V2	0°		8°	0°		0°

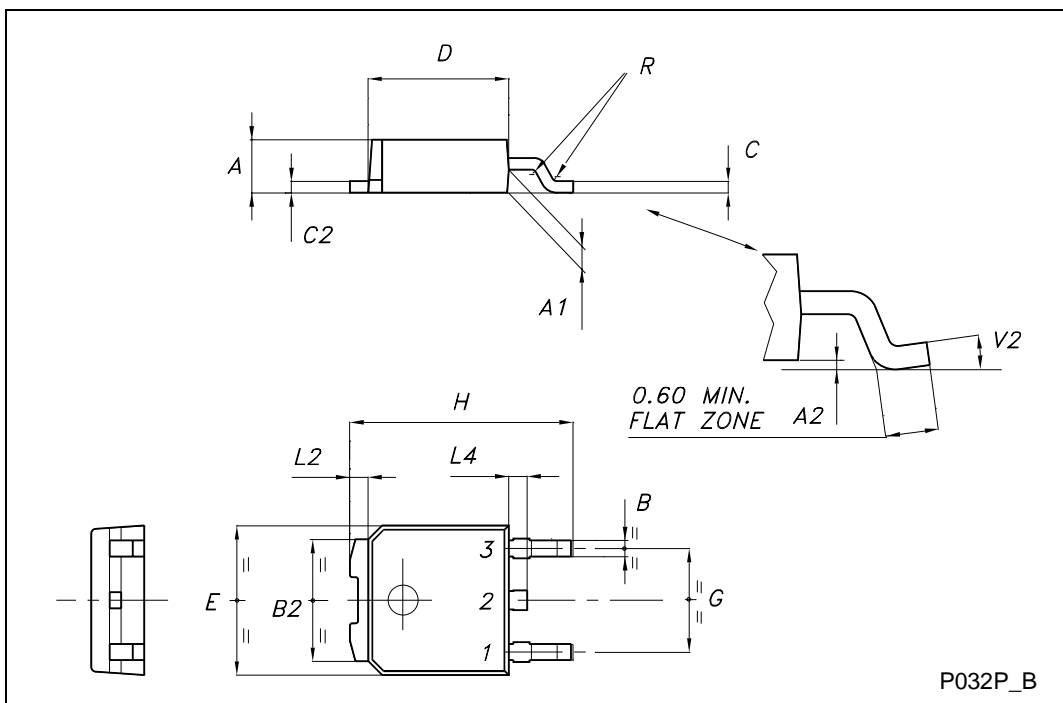

Information furnished is believed to be accurate and reliable. However, STMicroelectronics assumes no responsibility for the consequences of use of such information nor for any infringement of patents or other rights of third parties which may result from its use. No license is granted by implication or otherwise under any patent or patent rights of STMicroelectronics. Specification mentioned in this publication are subject to change without notice. This publication supersedes and replaces all information previously supplied. STMicroelectronics products are not authorized for use as critical components in life support devices or systems without express written approval of STMicroelectronics.

The ST logo is a trademark of STMicroelectronics.

All other names are the property of their respective owners.

© 2003 STMicroelectronics – All Rights reserved

STMicroelectronics GROUP OF COMPANIES

Australia - Belgium - Brazil - Canada - China - Czech Republic - Finland - France - Germany - Hong Kong - India - Israel - Italy - Japan - Malaysia - Malta - Morocco - Singapore - Spain - Sweden - Switzerland - United Kingdom - United States.

<http://www.st.com>