



STP16DPP05

Low voltage 16-bit constant current LED sink driver with output error detection

Features

- Low voltage power supply down to 3 V
- 16 constant current output channels
- Adjustable output current through external resistor
- Short and open output error detection
- Serial data IN/parallel data OUT
- 3.3 V MCU-driving capability
- Output current: 3 to 40 mA
- 30 MHz clock frequency
- Available in high thermal efficiency TSSOP exposed pad
- ESD protection: 2 kV HBM, 200 V MM

Description

The STP16DPP05 is a monolithic, low voltage, low current power 16-bit shift register designed for LED panel displays. The device features a 16-bit serial-in, parallel-out shift register that feeds a 16-bit D-type storage register. In the output stage, sixteen regulated current sources are designed to provide 3 to 40 mA of constant current to drive the LEDs. The STP16DPP05 features open and short LED detection on the outputs. The detection circuit checks for 3 different conditions that can occur on the output line: short to GND, short to V_O or open line.

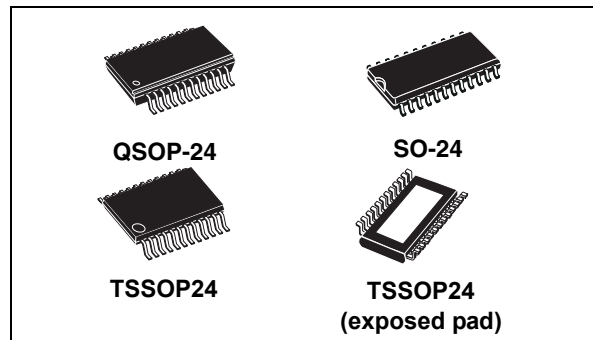

The data detection results are loaded in the shift registers and shifted out via the serial line output.

The detection functionality is implemented without increasing the pin count, through a secondary function of the output enable and latch pin (DM1 and DM2 respectively). A dedicated logic sequence allows the device to enter or exit from detection mode. The STP16DPP05 output current can be adjusted through an external resistor to control the light intensity of the LEDs. LED brightness is adjustable from 0% to 100% via the $\overline{OE}/DM2$ pin.

The STP16DPP05 guarantees a 20 V output driving capability, allowing users to connect more LEDs in series. The high 30 MHz clock frequency makes the device suitable for high data rate transmission. The 3.3 V supply is well suited for applications which interface a 3.3 V MCU. Compared to a standard TSSOP package, the TSSOP with exposed pad increases heat dissipation capability by a factor of 2.5

Table 1. Device summary

Order codes	Package	Packaging
STP16DPP05MTR	SO-24 (tape and reel)	1000 parts per reel
STP16DPP05TTR	TSSOP24 (tape and reel)	2500 parts per reel
STP16DPP05XTTR	TSSOP24 exposed pad (tape and reel)	2500 parts per reel
STP16DPP05PTR	QSOP-24	2500 parts per reel

Contents

- 1 Summary description 3**
 - 1.1 Pin connection and description 3
- 2 Electrical ratings 5**
 - 2.1 Absolute maximum ratings 5
 - 2.2 Thermal data 5
 - 2.3 Recommended operating conditions 6
- 3 Electrical characteristics 7**
- 4 Equivalent circuit and outputs 9**
- 5 Timing diagrams 11**
- 6 Typical characteristics 14**
- 7 Error detection mode functionality 18**
 - 7.1 Phase one: entering error detection mode 18
 - 7.2 Phase two: error detection 19
 - 7.3 Phase three: resuming normal mode 21
 - 7.4 Error detection conditions 21
- 8 Package mechanical data 23**
- 9 Revision history 31**

1 Summary description

Table 2. Typical current accuracy

Output voltage	Current accuracy		Output current	V _{DD}	Temperature
	Between bits	Between ICs			
≥ 1.3 V	± 1%	± 2%	5 to 40 mA	3.3 V to 5 V	25 °C

1.1 Pin connection and description

Figure 1. Pin connection

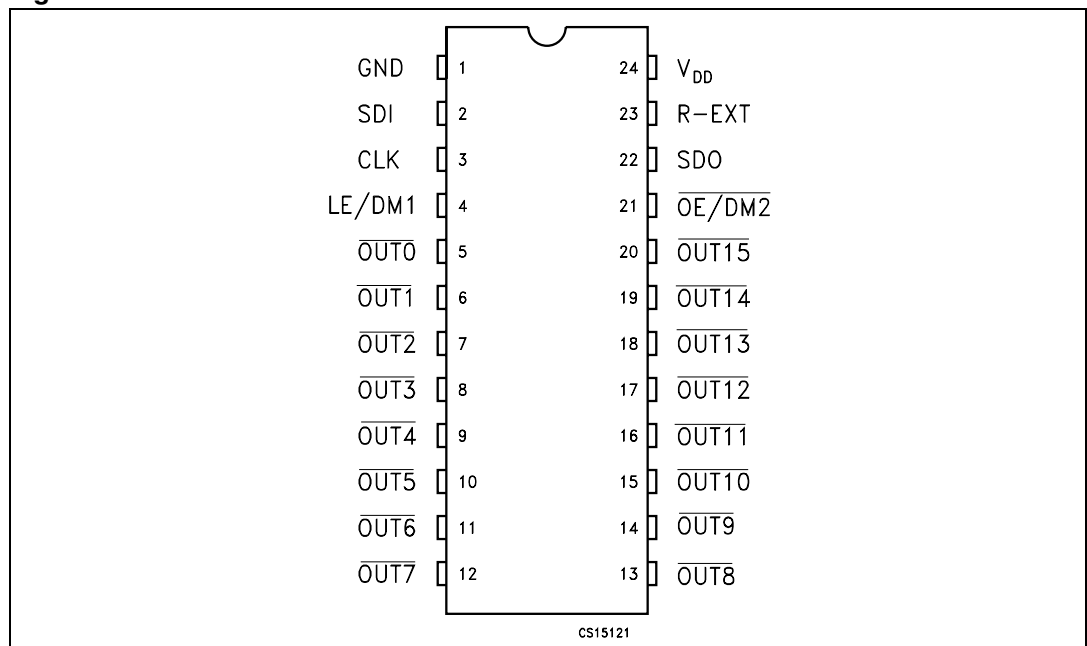

Note: The exposed pad should be electrically connected to a metal land electrically isolated or connected to ground.

Table 3. Pin description

Pin n°	Symbol	Name and function
1	GND	Ground terminal
2	SDI	Serial data input terminal
3	CLK	Clock input terminal
4	LE/DM1	Latch input terminal - detect mode 1 (see operation principle)
5-20	$\overline{\text{OUT 0-15}}$	Output terminal
21	$\overline{\text{OE/DM2}}$	Input terminal of output enable (active low) - detect mode 1 (see operation principle)
22	SDO	Serial data out terminal
23	R-EXT	Input terminal for an external resistor for constant current programming
24	V _{DD}	Supply voltage terminal

2 Electrical ratings

2.1 Absolute maximum ratings

Stressing the device above the ratings listed in the “absolute maximum ratings” table may cause permanent damage to the device. These are stress ratings only and operation of the device at these or any other condition above those indicated in the operating sections of this specification is not implied. Exposure to absolute maximum rating conditions for extended periods may affect device reliability.

Table 4. Absolute maximum ratings

Symbol	Parameter	Value	Unit
V_{DD}	Supply voltage	0 to 7	V
V_O	Output voltage	-0.5 to 20	V
I_O	Output current	50	mA
V_I	Input voltage	-0.4 to V_{DD}	V
I_{GND}	GND terminal current	800	mA
f_{CLK}	Clock frequency	50	MHz
T_J	Junction temperature range ⁽¹⁾	-40 to +170	°C

1. Such absolute value is based on the thermal shutdown protection.

2.2 Thermal data

Table 5. Thermal data

Symbol	Parameter	Value	Unit	
T_A	Operating free-air temperature range	-40 to +125	°C	
T_{J-OPR}	Operating thermal junction temperature range	-40 to +150	°C	
T_{STG}	Storage temperature range	-55 to +150	°C	
R_{thJA}	Thermal resistance junction-ambient ⁽¹⁾	SO-24	42.7	°C/W
		TSSOP24	55	°C/W
		TSSOP24 ⁽²⁾ Exposed Pad	37.5	°C/W
		QSOP-24	55	°C/W

1. According with JEDEC standard 51-7B

2. The exposed pad should be soldered directly to the PCB to obtain the thermal benefits.

2.3 Recommended operating conditions

Table 6. Recommended operating conditions

Symbol	Parameter	Test conditions	Min.	Typ.	Max.	Unit
V_{DD}	Supply voltage		3.0		5.5	V
V_O	Output voltage				20	V
I_O	Output current	OUTn	3		40	mA
I_{OH}	Output current	SERIAL-OUT			+1	mA
I_{OL}	Output current	SERIAL-OUT			-1	mA
V_{IH}	Input voltage		$0.7 V_{DD}$		V_{DD}	V
V_{IL}	Input voltage		-0.3		$0.3 V_{DD}$	V
t_{wLAT}	LE/DM1 pulse width	$V_{DD} = 3.0 \text{ V to } 5.0 \text{ V}$	20			ns
t_{wCLK}	CLK pulse width		10			ns
t_{wEN}	$\overline{OE/DM2}$ pulse width		100			ns
$t_{SETUP(D)}$	Setup time for DATA		8			ns
$t_{HOLD(D)}$	Hold time for DATA		5			ns
$t_{SETUP(L)}$	Setup time for LATCH		8			ns
f_{CLK}	Clock frequency		Cascade operation ⁽¹⁾			30

1. If the device is connected in cascade, it may not be possible to achieve the maximum data transfer. Please consider the timings carefully.

3 Electrical characteristics

$V_{DD} = 3.3\text{ V to }5\text{ V}$, $T_A = 25\text{ °C}$, unless otherwise specified.

Table 7. Electrical characteristics

Symbol	Parameter	Test conditions	Min.	Typ.	Max.	Unit
V_{IH}	Input voltage high level		$0.7 V_{DD}$		V_{DD}	V
V_{IL}	Input voltage low level		GND		$0.3 V_{DD}$	V
I_{OH}	Output leakage current	$V_{OH} = 20\text{ V}$			1	μA
V_{OL}	Output voltage (serial-OUT)	$I_{OL} = 1\text{ mA}$			0.4	V
V_{OH}	Output voltage (serial-OUT)	$I_{OH} = -1\text{ mA}$	$V_{DD}-0.4\text{V}$			V
I_{OL1}	Output current	$V_O = 0.3\text{ V}$, $R_{ext} = 4\text{ k}\Omega$	4.75	5	5.25	mA
I_{OL2}		$V_O = 0.3\text{ V}$, $R_{ext} = 1\text{ k}\Omega$	19	20	21	
I_{OL3}		$V_O = 1.3\text{ V}$, $R_{ext} = 497\ \Omega$	38	40	42	
ΔI_{OL1}	Output current error between bit (All output ON)	$V_O = 0.3\text{ V}$, $I_O = 5\text{ mA}$ $R_{EXT} = 4\text{ k}\Omega$		± 1	± 5	%
ΔI_{OL2}		$V_O = 0.3\text{ V}$, $I_O = 20\text{ mA}$ $R_{EXT} = 980\ \Omega$		± 0.5	± 3	
ΔI_{OL3}		$V_O = 1.3\text{ V}$, $I_O = 40\text{ mA}$ $R_{EXT} = 490\ \Omega$		± 0.5	± 3	
$R_{SIN(up)}$	Pull-up resistor		150	300	600	$\text{k}\Omega$
$R_{SIN(down)}$	Pull-down resistor		100	200	400	$\text{k}\Omega$
$I_{DD(OFF1)}$	Supply current (OFF)	$R_{EXT} = 1\text{ k}\Omega$, $I_{OUT} = 20\text{ mA}$, OUT 0 to 15 = OFF		5.4	7.5	mA
$I_{DD(OFF2)}$		$R_{EXT} = 497\ \Omega$, $I_{OUT} = 40\text{ mA}$ OUT 0 to 15 = OFF		8.0	9.5	
$I_{DD(ON1)}$	Supply current (ON)	$R_{EXT} = 1\text{ k}\Omega$, $I_{OUT} = 20\text{ mA}$, OUT 0 to 15 = ON		5.5	7.5	
$I_{DD(ON2)}$		$R_{EXT} = 497\ \Omega$, $I_{OUT} = 40\text{ mA}$ OUT 0 to 15 = ON		8.1	9.5	
Thermal	Thermal protection			170		$^{\circ}\text{C}$

$V_{DD} = 3.3\text{ V to }5\text{ V}$, $T_A = 25\text{ }^\circ\text{C}$, unless otherwise specified.

Table 8. Switching characteristics

Symbol	Parameter	Test conditions	Min	Typ	Max	Unit	
t_{PLH1}	Propagation delay time, $\overline{\text{CLK-OUTn}}$, $\text{LE/DM1} = \text{H}$, $\text{OE/DM2} = \text{L}$	$V_{IH} = V_{DD}$ $V_{IL} = \text{GND}$ $I_O = 20\text{ mA}$ $R_{EXT} = 1\text{ K}\Omega$ $C_L = 10\text{ pF}$ $V_L = 3.0\text{ V}$ $R_L = 60\text{ }\Omega$	$V_{DD} = 3.3\text{ V}$	35.5	44.5	ns	
			$V_{DD} = 5\text{ V}$	18.5	24		
t_{PLH2}	Propagation delay time, $\overline{\text{LE/DM1-OUTn}}$, $\text{OE/DM2} = \text{L}$		$V_{DD} = 3.3\text{ V}$	41.5	50	ns	
			$V_{DD} = 5\text{ V}$	23	29		
t_{PLH3}	Propagation delay time, $\overline{\text{OE/DM2-OUTn}}$, $\text{LE} = \text{H}$		$V_{DD} = 3.3\text{ V}$	45	54	ns	
			$V_{DD} = 5\text{ V}$	25	31		
t_{PLH}	Propagation delay time, $\overline{\text{CLK-SDO}}$		$V_{DD} = 3.3\text{ V}$	15	21	31	ns
			$V_{DD} = 5\text{ V}$	11	15	21	
t_{PHL1}	Propagation delay time, $\overline{\text{CLK-OUTn}}$, $\text{LE/DM1} = \text{H}$, $\text{OE/DM2} = \text{L}$		$V_{DD} = 3.3\text{ V}$		13.7	18	ns
			$V_{DD} = 5\text{ V}$		8.8	12.5	
t_{PHL2}	Propagation delay time, $\overline{\text{LE/DM1-OUTn}}$, $\text{OE/DM2} = \text{L}$		$V_{DD} = 3.3\text{ V}$		17	22	ns
			$V_{DD} = 5\text{ V}$		13	17	
t_{PHL3}	Propagation delay time, $\overline{\text{OE/DM2-OUTn}}$, $\text{LE/DM1} = \text{H}$		$V_{DD} = 3.3\text{ V}$		12.7	17	ns
			$V_{DD} = 5\text{ V}$		9.5	13	
t_{PHL}	Propagation delay time, $\overline{\text{CLK-SDO}}$	$V_{DD} = 3.3\text{ V}$	17.5	24	36	ns	
		$V_{DD} = 5\text{ V}$	12.5	17	25		
t_{ON}	Output rise time 10~90% of voltage waveform	$V_{DD} = 3.3\text{ V}$		28	39	ns	
		$V_{DD} = 5\text{ V}$		17	23		
t_{OFF}	Output fall time 90~10% of voltage waveform	$V_{DD} = 3.3\text{ V}$		4.5	6	ns	
		$V_{DD} = 5\text{ V}$		3.5	5		
t_r	CLK rise time ⁽¹⁾				5000	ns	
t_f	CLK fall time ⁽¹⁾				5000	ns	

1. In order to achieve high cascade data transfer, please consider t_r/t_f timings carefully.

4 Equivalent circuit and outputs

Figure 2. $\overline{\text{OE/DM2}}$ terminal

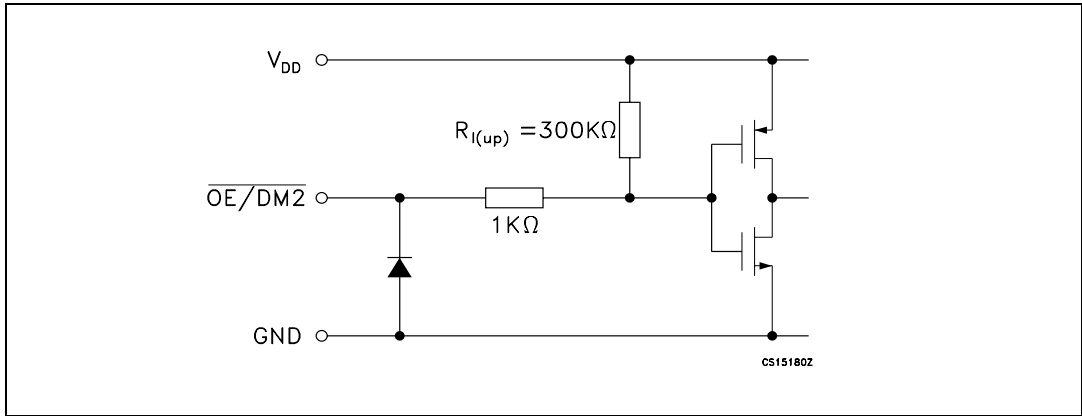

Figure 3. LE/DM1 terminal

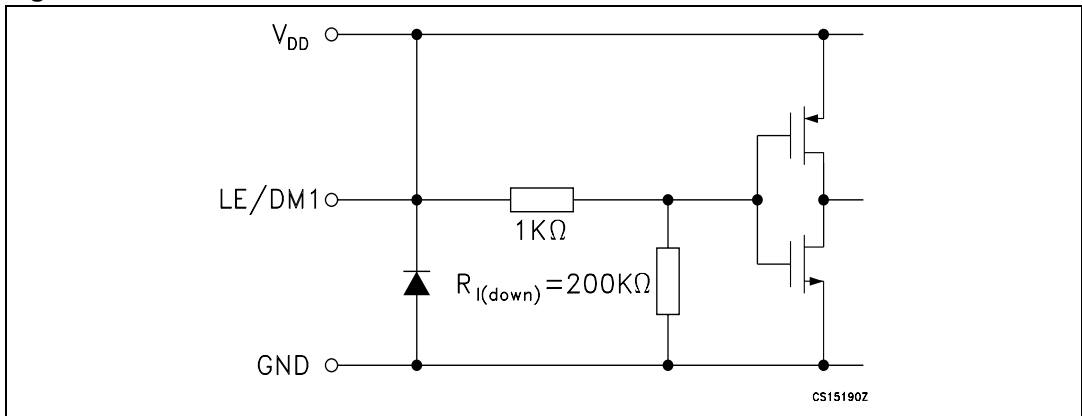

Figure 4. CLK, SDI terminal

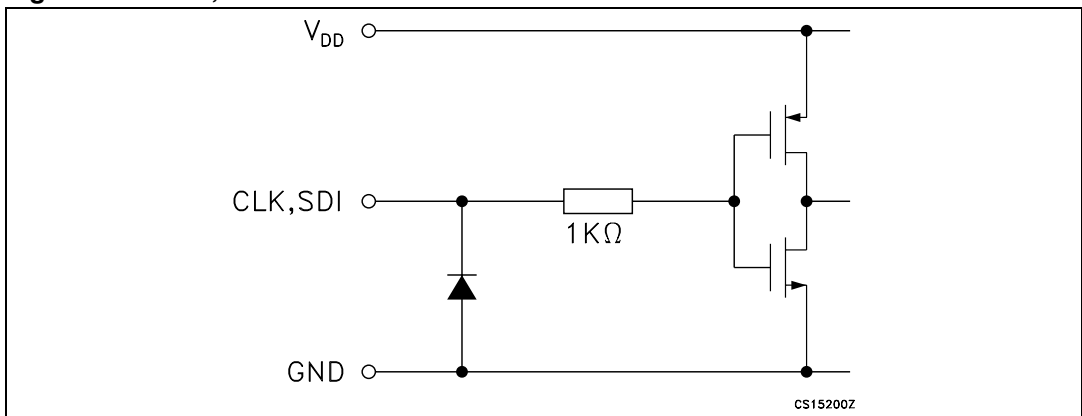

Figure 5. SDO terminal

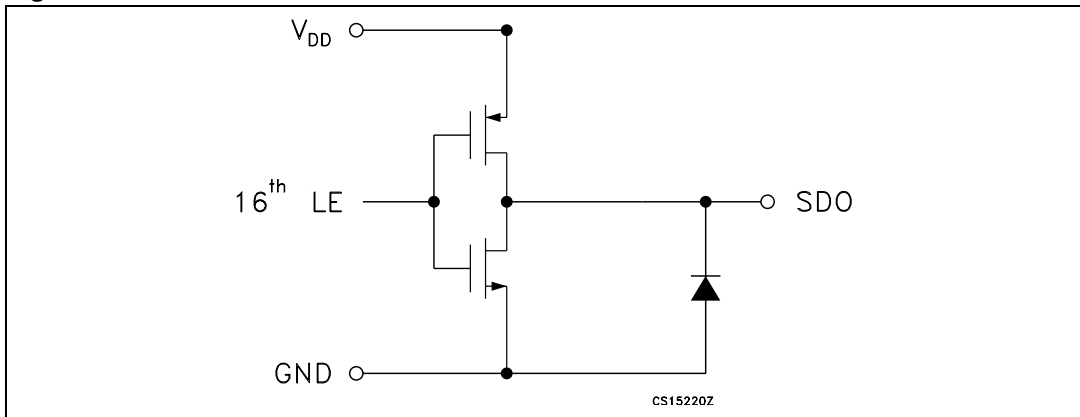
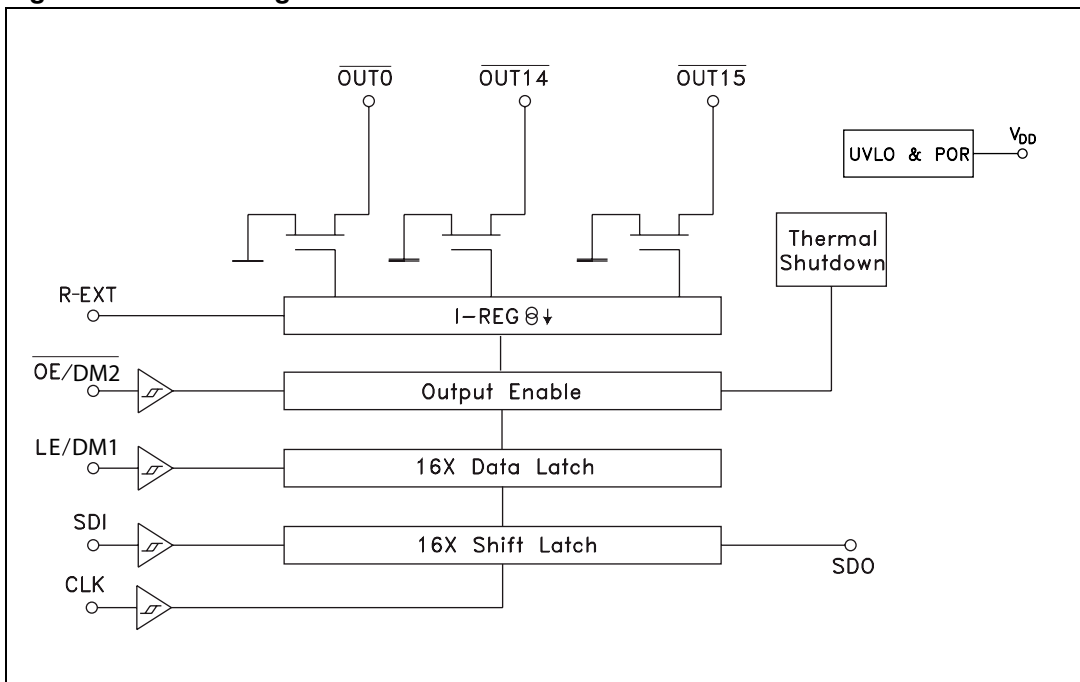

Figure 6. Block diagram



5 Timing diagrams

Table 9. Truth table

CLOCK	LE/DM1	OE/DM2	SERIAL-IN	OUT0 OUT7 OUT15	SDO
	H	L	Dn	Dn Dn - 7 Dn -15	Dn - 15
	L	L	Dn + 1	No change	Dn - 14
	H	L	Dn + 2	Dn + 2 Dn - 5 Dn -13	Dn - 13
	X	L	Dn + 3	Dn + 2 Dn - 5 Dn -13	Dn - 13
	X	H	Dn + 3	OFF	Dn - 13

Note: $OUTn = ON$ when $Dn = H$ $OUTn = OFF$ when $Dn = L$

Figure 7. Timing diagram

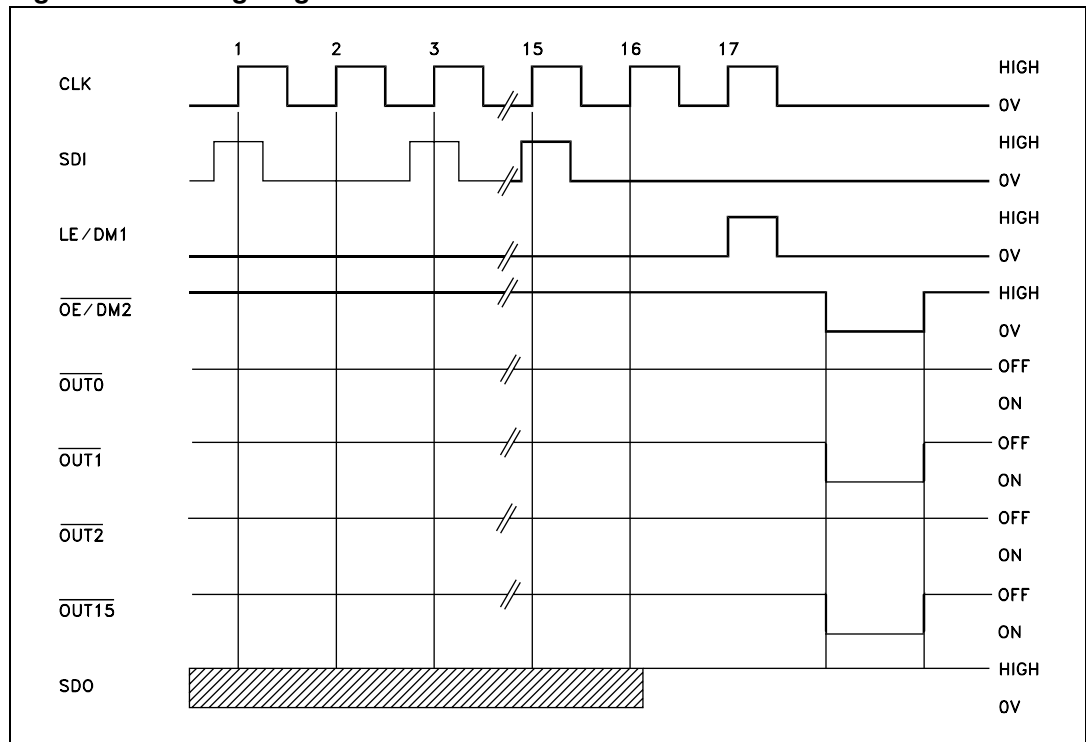

- Note:
- 1 Latch and output enable terminals are level-sensitive and are not synchronized with rising or falling edge of CLK signal.
 - 2 When LE/DM1 terminal is low level, the latch circuit holds previous set of data.
 - 3 When LE/DM1 terminal is high level, the latch circuit refreshes new set of data from SDI chain.
 - 4 When OE/DM2 terminal is at low level, the output terminals Out 0 to Out 15 respond to data in the latch circuits, either '1' for ON or '0' for OFF.
 - 5 When OE/DM2 terminal is at high level, all output terminals are switched OFF.

Table 10. Enable IO: shutdown truth table

CLOCK	LE/DM1	SDI ₀ SDI ₇ SDI ₁₅	SH	Auto Power-up	$\overline{\text{OUTn}}$
┌	H	All = L	Active	Not active ⁽¹⁾	OFF
┌	L	No change	No change	No change	No change
┌	H	One or more = H	Not active	Active	X ⁽²⁾

1. At power-up, the device starts in shutdown mode.
2. Undefined.

Figure 8. Clock, serial-in, serial-out

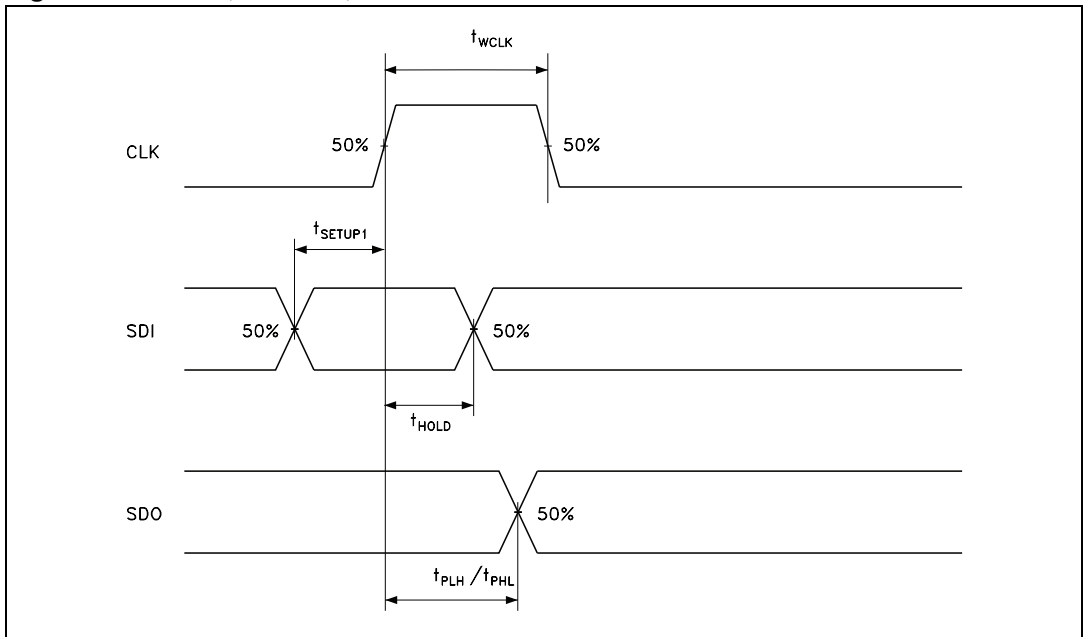

Figure 9. Clock, serial-in, latch, enable, outputs

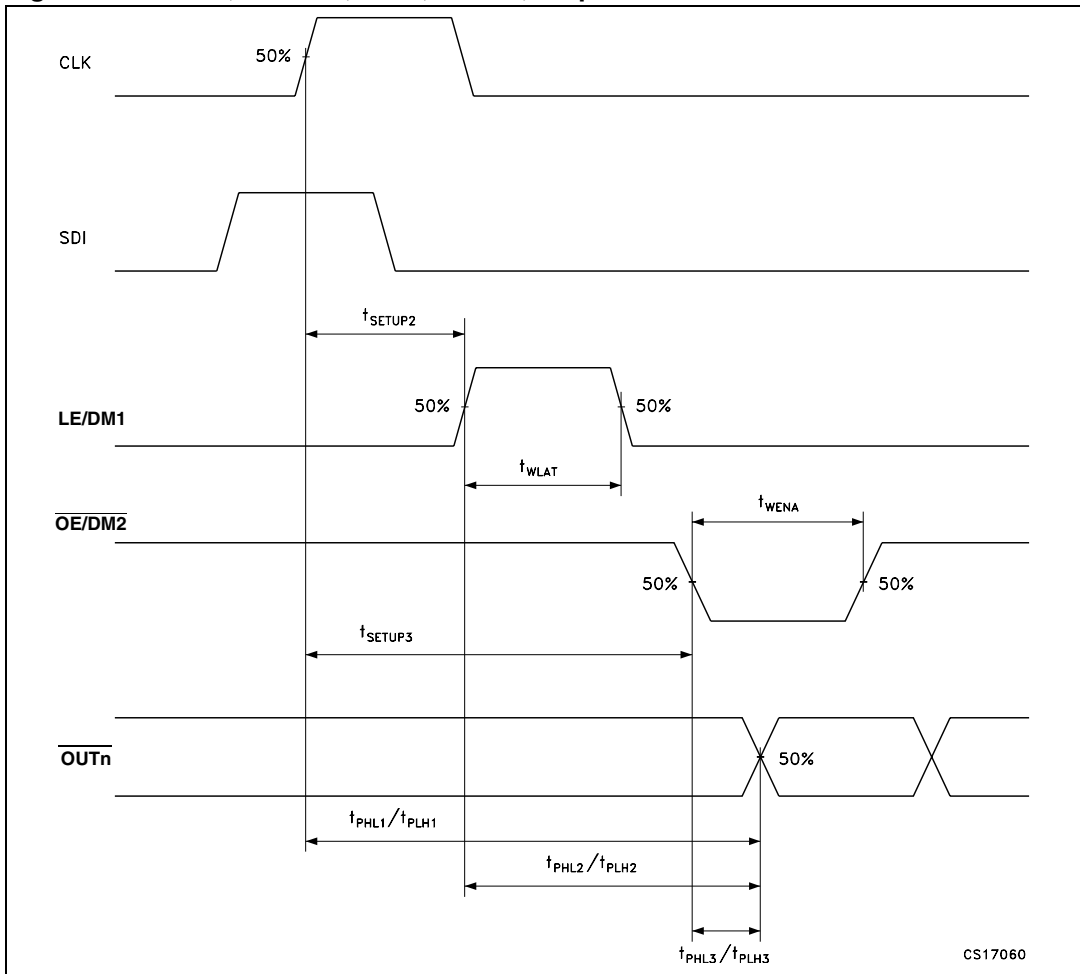
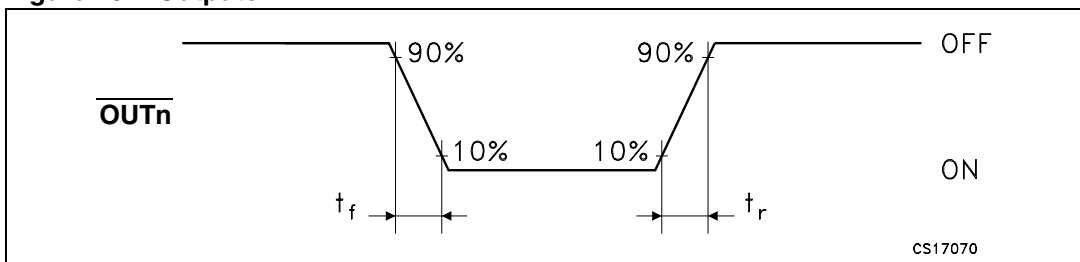

Figure 10. Outputs



6 Typical characteristics

Figure 11. Output current vs. R-EXT resistor

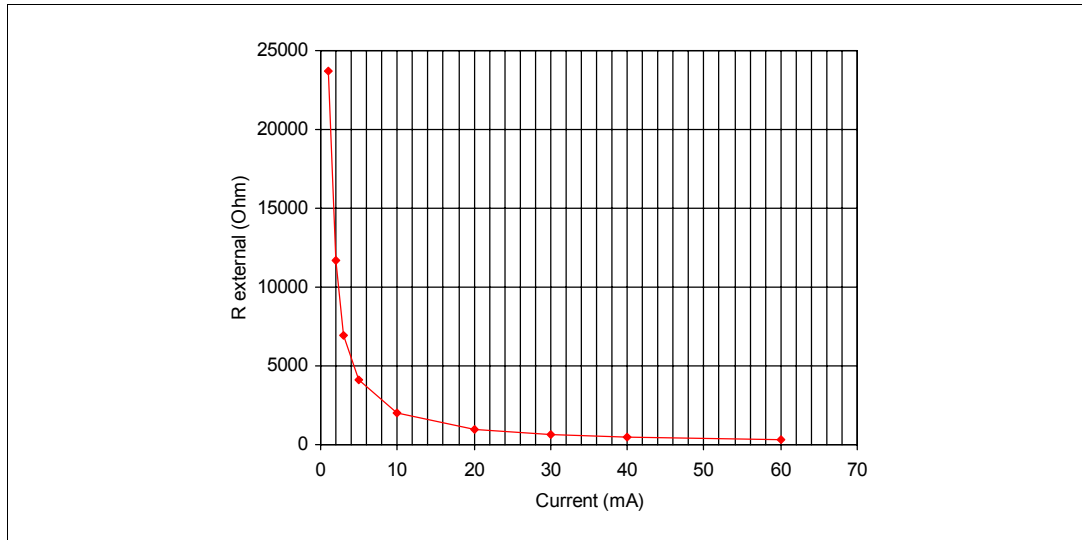

Table 11. Output current vs. R-EXT resistor

R-EXT (Ω)	Output current (mA)
23700	1
11730	2
6930	3
4090	5
2025	10
1000	20
667	30
497	40
331	60

Conditions:

Temperature = 25 °C, V_{DD} = 3.3 V; 5.0 V, I_{SET} = 3 mA; 5 mA; 10 mA; 20 mA; 50 mA; 60 mA.

Figure 12. I_{SET} vs. dropout voltage (V_{drop})

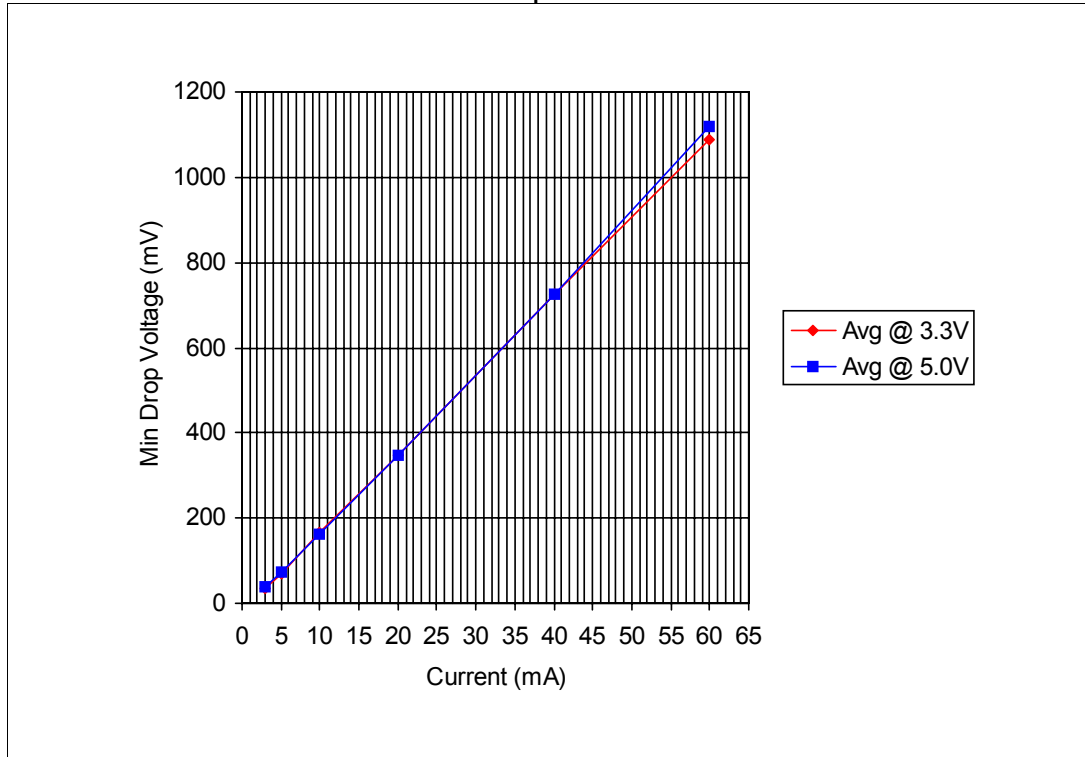

Table 12. I_{SET} vs. dropout voltage (V_{drop})

I_{out} (mA)	Avg (mV) @ 3.3 V	Avg (mV) @ 5.0 V
3	36	37
5	71	72
10	163	163
20	346	347
40	724	726
60	1080	1110

$T_A = 25\text{ }^\circ\text{C}$, $V_{dd} = 3.3\text{ V}; 5\text{ V}$

Figure 13. Output current vs. $\pm \Delta I_{OL}(\%)$

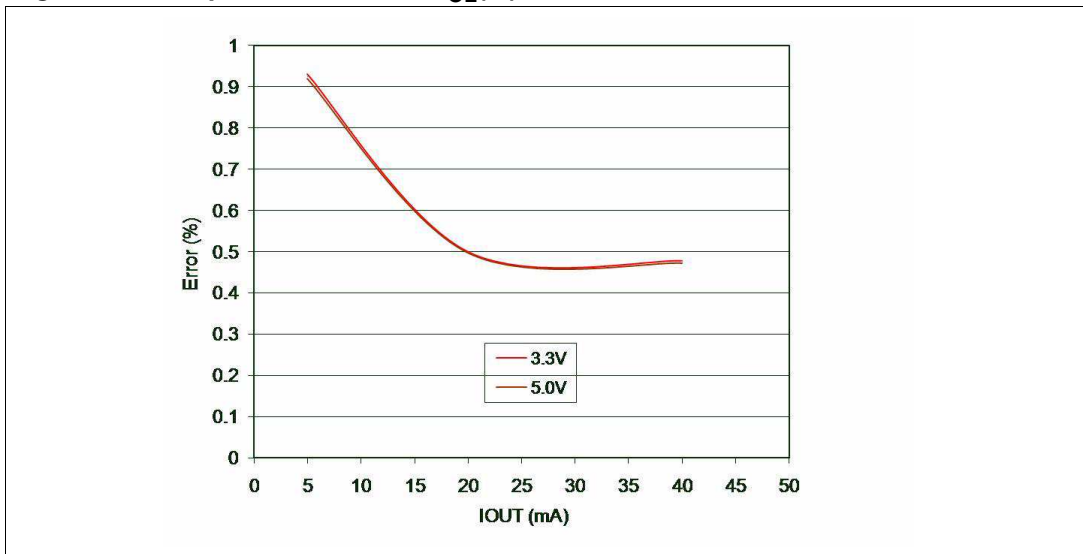

Figure 14. I_{dd} ON/OFF

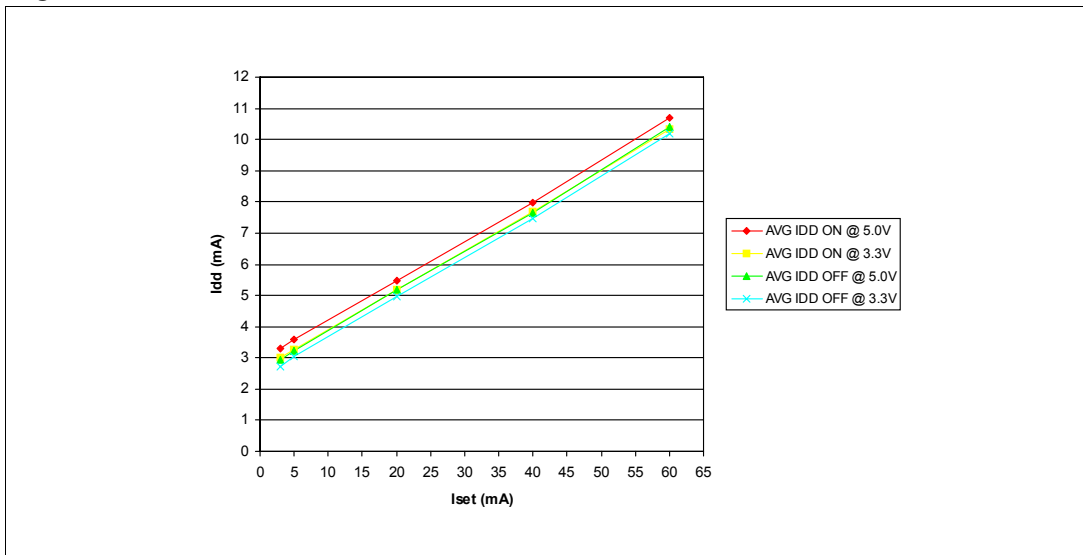
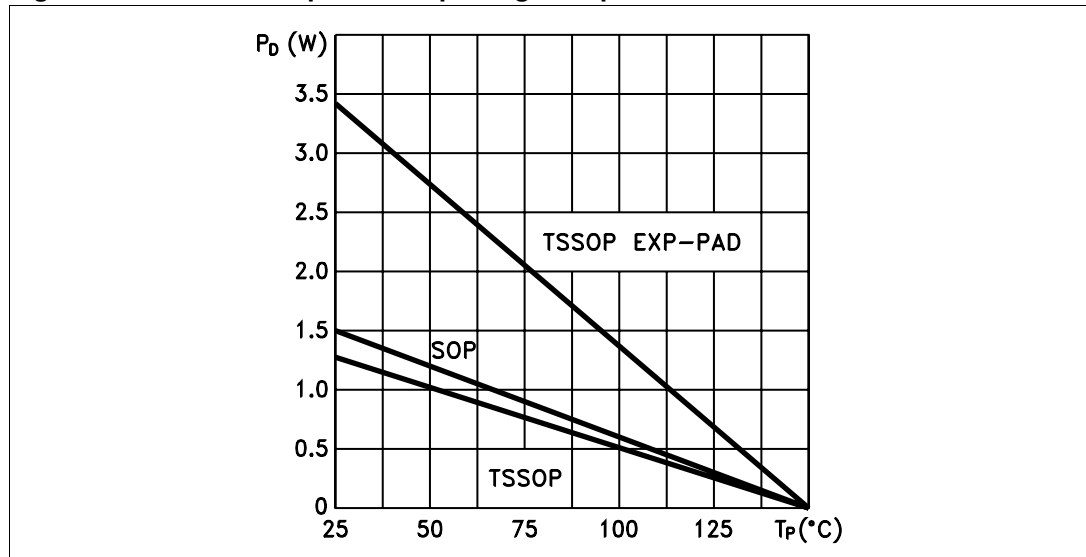

Figure 15. Power dissipation vs. package temperature



Note: The exposed pad should be soldered to the PCB to obtain the thermal benefits.

Figure 16. Turn ON output current characteristics (1)

Figure 17. Turn OFF output current characteristics (2)

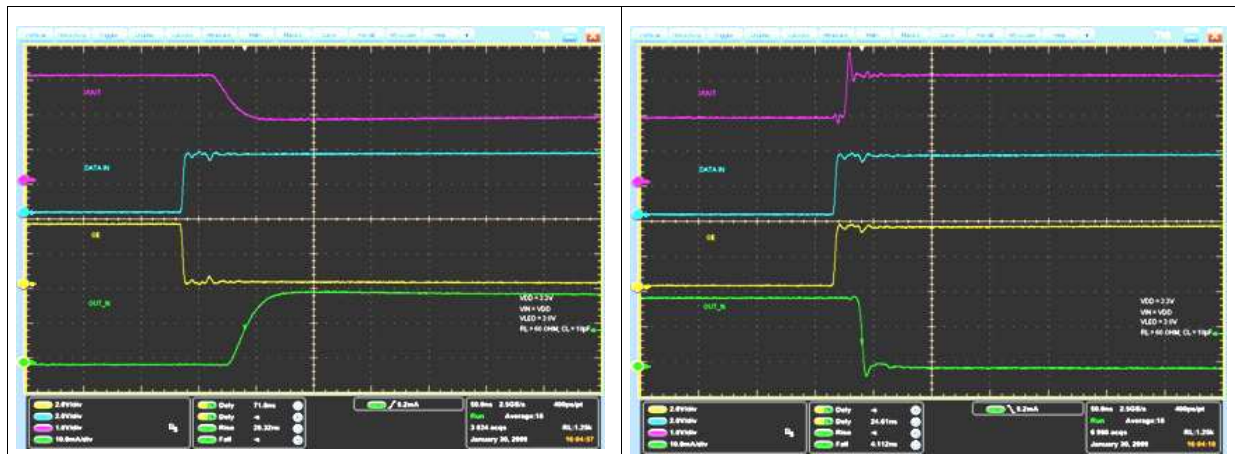

Electrical conditions:

Vdd = 3.3 V, Vin = Vdd, Vled = 3.0 V, RL = 60 Ω, CL = 10 pF

Ch1 (Yellow) = $\overline{OE/DM2}$, Ch2 (Blue) = SDI, Ch3 (Purple) = VOUT, Ch4 (Green) = OUT

1. The reference level for the T_{ON} characteristics is 50% of $\overline{OE/DM2}$ signal and 90% of output current
2. The reference level for the T_{OFF} characteristics is 50% of $\overline{OE/DM2}$ signal and 10% of output current

7 Error detection mode functionality

7.1 Phase one: entering error detection mode

From the “normal mode” condition the device can switch to “error mode” by a logic sequence on the $\overline{OE/DM2}$ and LE/DM1 pins, as shown in the following table and diagram:

Table 13. Entering error detection mode - truth table

CLK	1°	2°	3°	4°	5°
$\overline{OE/DM2}$	H	L	H	H	H
LE/DM1	L	L	L	H	L

Figure 18. Entering error detection mode - timing diagram

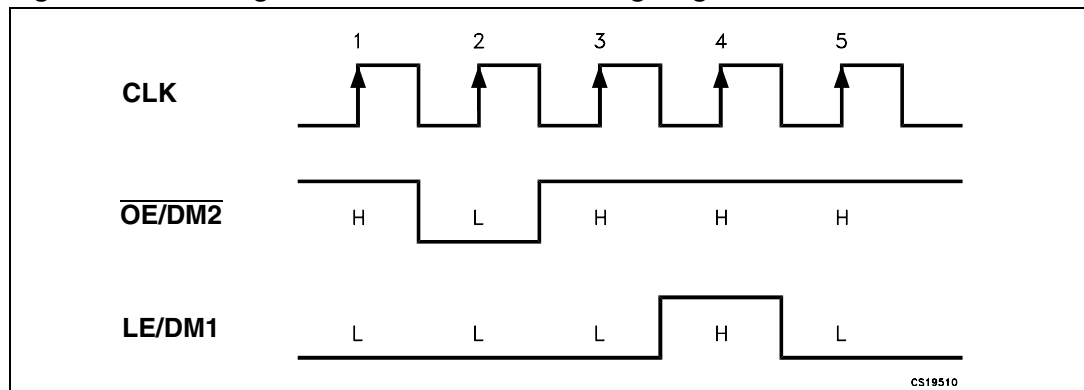

After these five CLK cycles, the device goes into “error detection mode” and at the rising edge of the 6th CLK cycle, the SDI data are ready for sampling.

7.2 Phase two: error detection

The 16 data bits must be set to “1” in order for all the outputs to be ON during error detection. The data are latched by LE/DM1, after which the outputs are ready for the detection process. When the microcontroller switches the OE/DM2 to LOW, the device drives the LEDs to analyze if an OPEN or SHORT condition has occurred.

Figure 19. Detection diagram

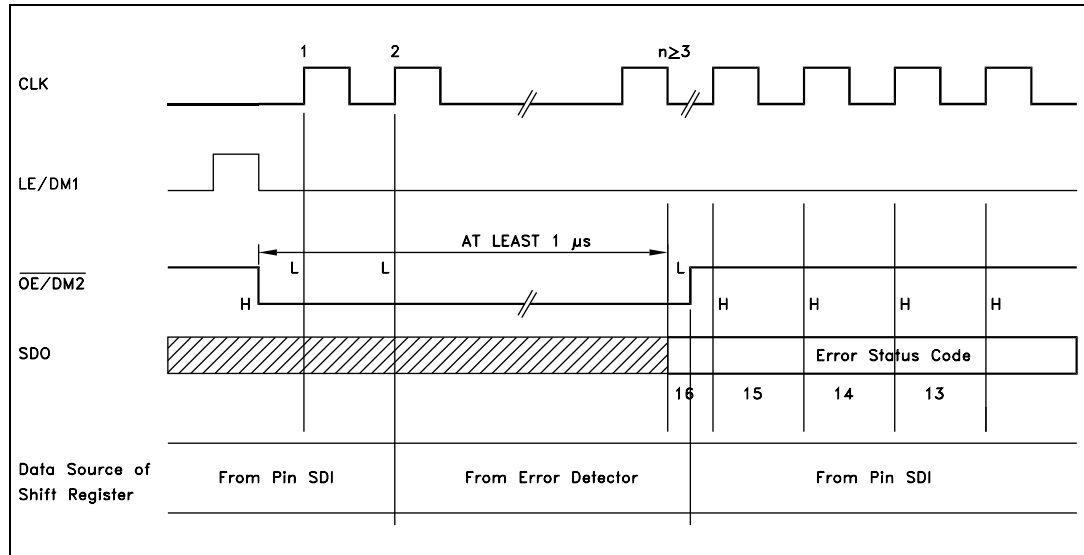

The status of the LEDs is detected in at least 1 microsecond, and after this period the microcontroller sets OE/DM2 to HIGH state and the output data detection result is sent to the microcontroller via SDO.

Error detection mode and normal mode both use the same data format. As soon as all the detection data bits are available on the serial line, the device may return to normal mode of operation. To re-detect the status, the device must first return to normal mode and reenter error detection mode.

Figure 20. Timing example for open and/or short-circuit detection

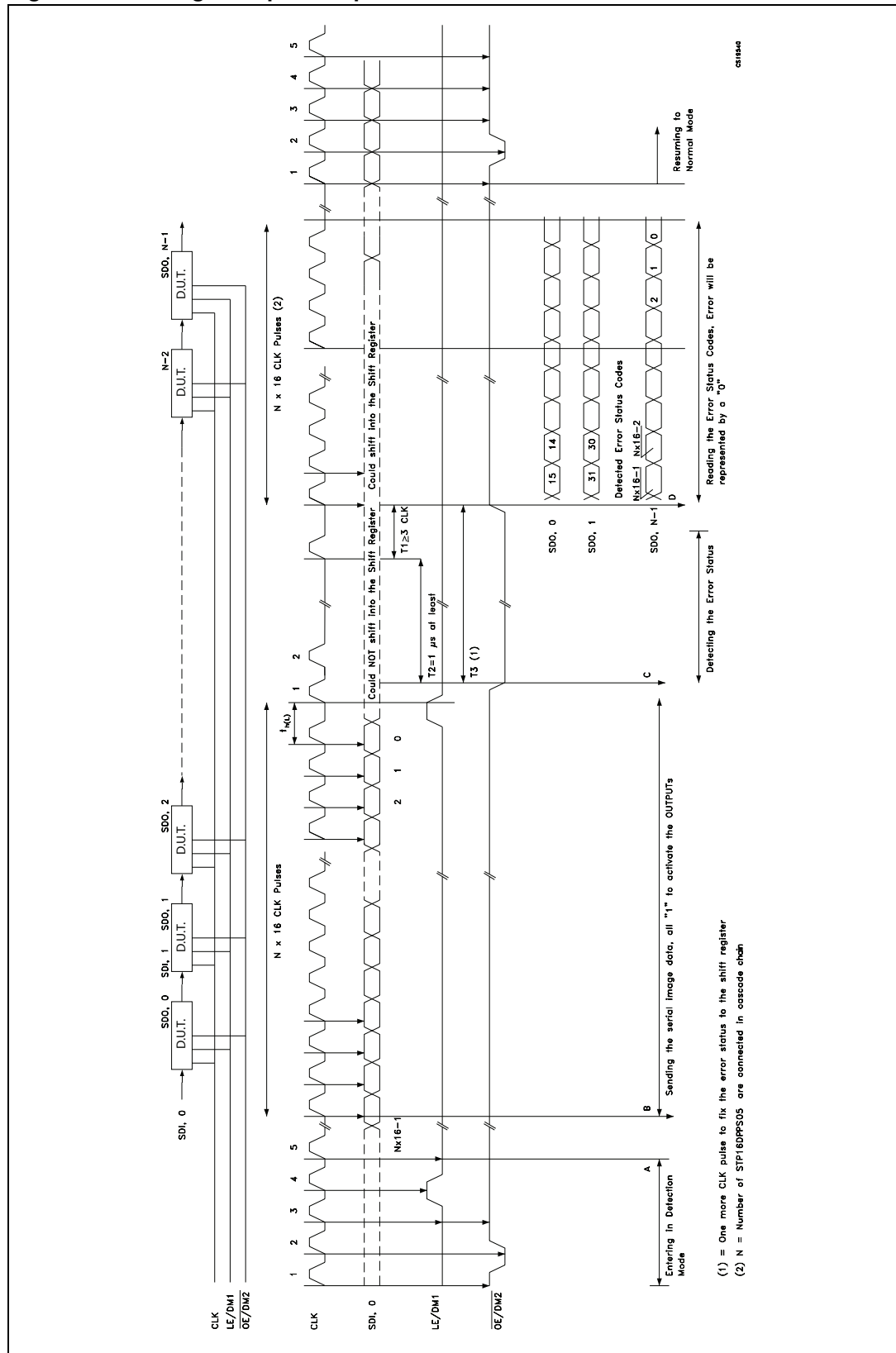

7.3 Phase three: resuming normal mode

The sequence for reentering normal mode is shown in the following table:

Figure 21. Resuming normal mode - timing diagram

CLK	1°	2°	3°	4°	5°
$\overline{OE/DM2}$	H	L	H	H	H
LE/DM1	L	L	L	L	L

Note: For proper device operation, the “entering error detection” sequence must be followed by a “resume mode” sequence, it is not possible to insert consecutive equal sequences.

7.4 Error detection conditions

Table 14. Detection conditions ($V_{DD} = 3.3$ to 5 V, temperature range -40 to 125 °C)

Configuration	Detect mode	Detection results		
SW-1 or SW-3b	Open line or output short to GND detected	$\implies I_{ODEC} \leq 0.5 \times I_O$	No error detected	$\implies I_{ODEC} \geq 0.5 \times I_O$
SW-2 or SW-3a	Short on LED or short to V-LED detected	$\implies V_O \geq 2.6$ V	No error detected	$\implies V_O \leq 2.3$ V

Note: Where: I_O = the output current programmed by the R-EXT, I_{ODEC} = the detected output current in detection mode

Figure 22. Detection circuit

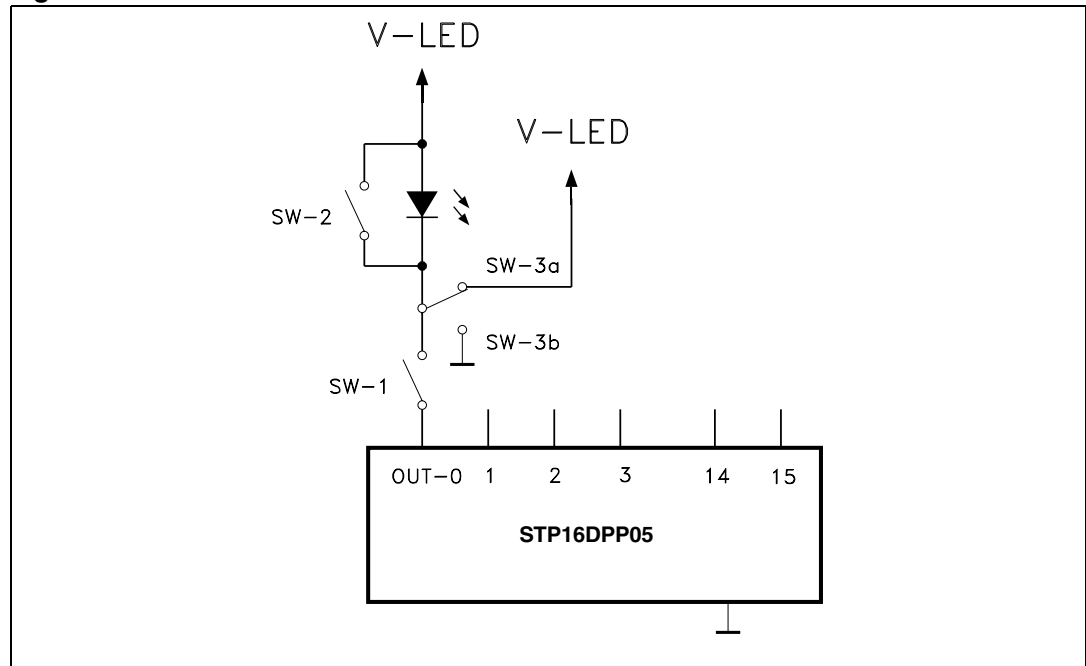
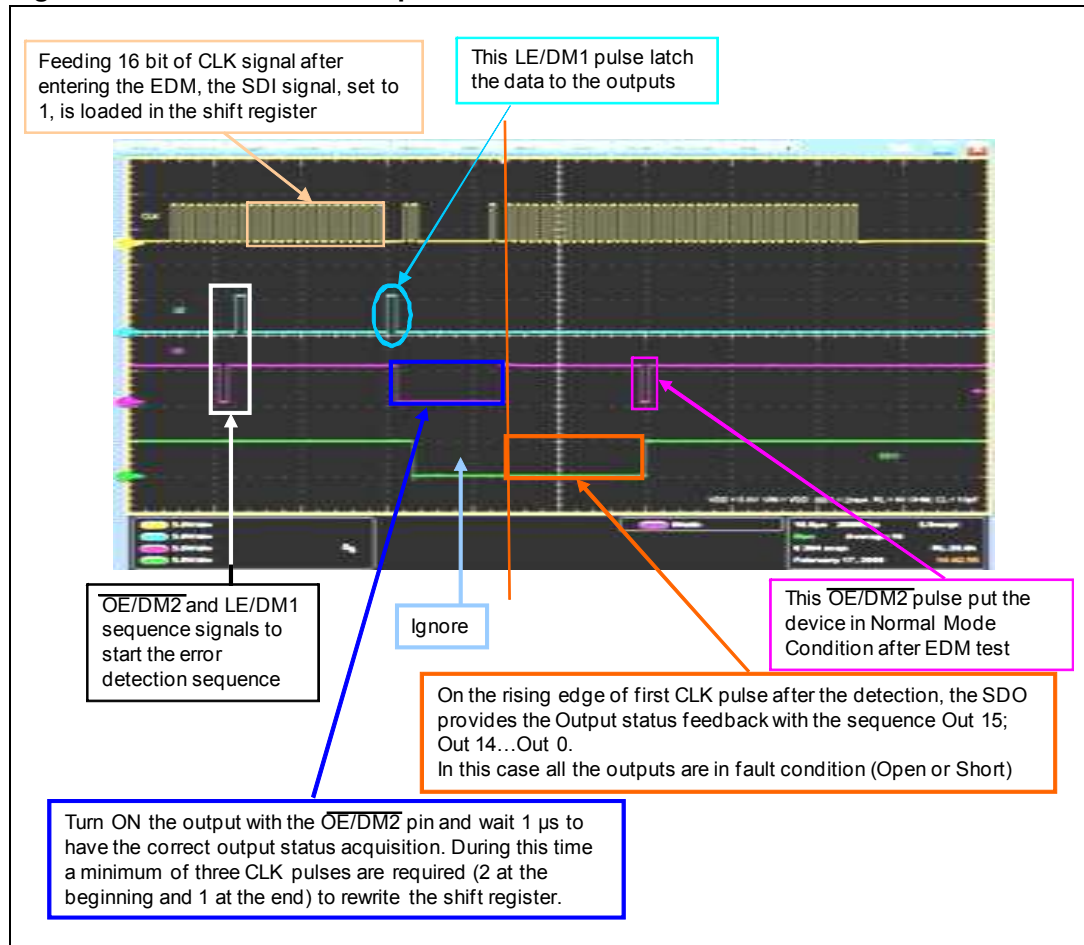

Figure 23. Error detection sequence



8 Package mechanical data

In order to meet environmental requirements, ST offers these devices in different grades of ECOPACK® packages, depending on their level of environmental compliance. ECOPACK® specifications, grade definitions and product status are available at: www.st.com. ECOPACK® is an ST trademark.

Table 15. QSOP-24 mechanical data

Dim.	mm.			inch		
	Min	Typ	Max	Min	Typ	Max
A	1.54	1.62	1.73	0.061	0.064	0.068
A1	0.1	0.15	0.25	0.004	0.006	0.010
A2		1.47			0.058	
b	0.31	0.2		0.012	0.008	
c	0.254	0.17		0.010	0.007	
D	8.56	8.66	8.76	0.337	0.341	0.345
E	5.8	6	6.2	0.228	0.236	0.244
E1	3.8	3.91	4.01	0.150	0.154	0.158
e		0.635			0.025	
L	0.4	0.635	0.89	0.016	0.025	0.035
h	0.25	0.33	0.41	0.010	0.013	0.016
<	8°	0°				

Figure 24. QSOP-24 package dimensions

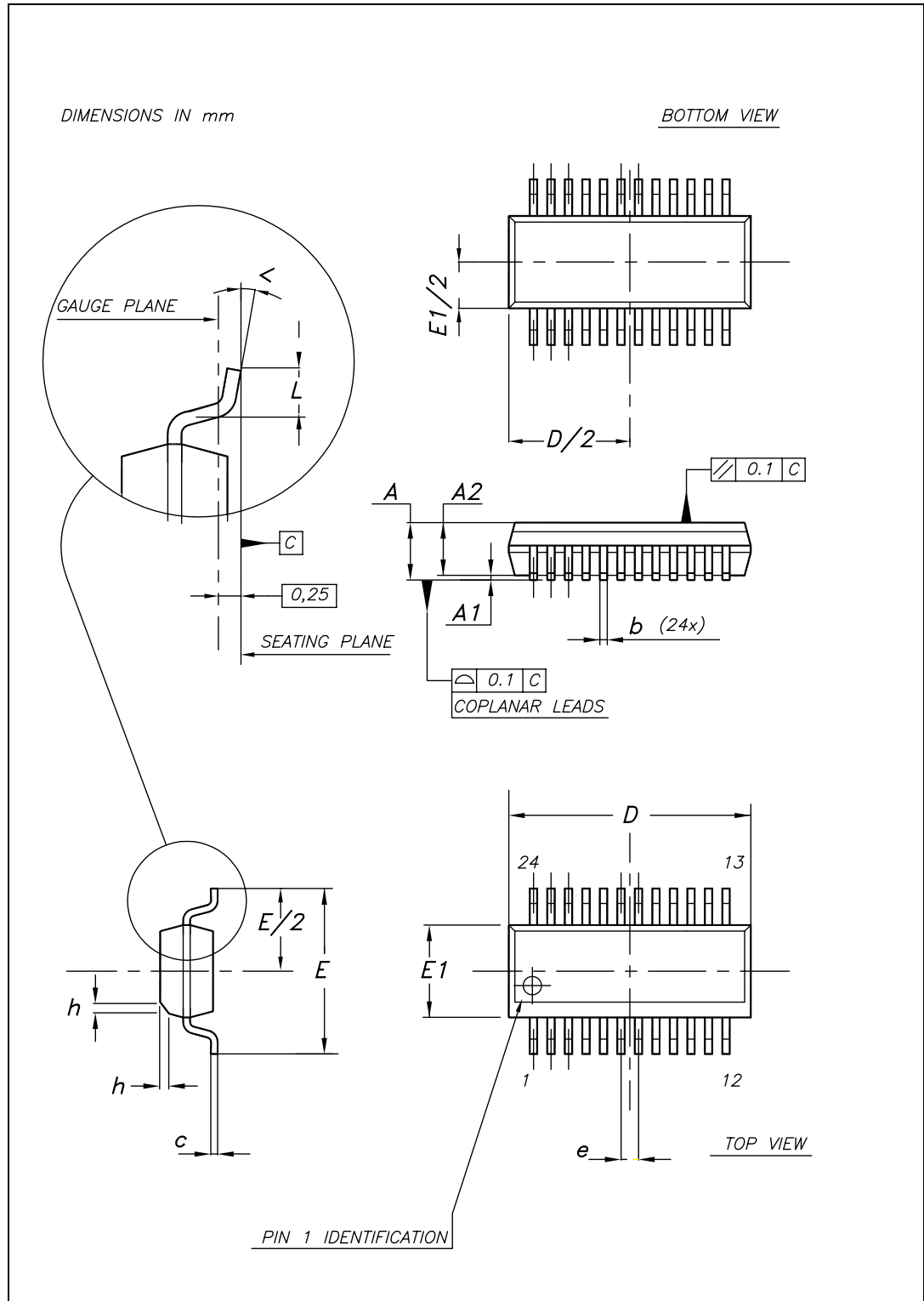

Table 16. QSOP-24 tape and reel

Dim.	mm.			Inches		
	Min	Typ	Max	Min	Typ	Max
R1	12.8	13	13.5	5.039	5.118	5.315
R2		330			129.921	
R3		100			39.37	
eint		16.4			6.457	
e1	1.5	2	2.5	0.591	0.787	0.984

Figure 25. QSOP-24 tape and reel dimensions

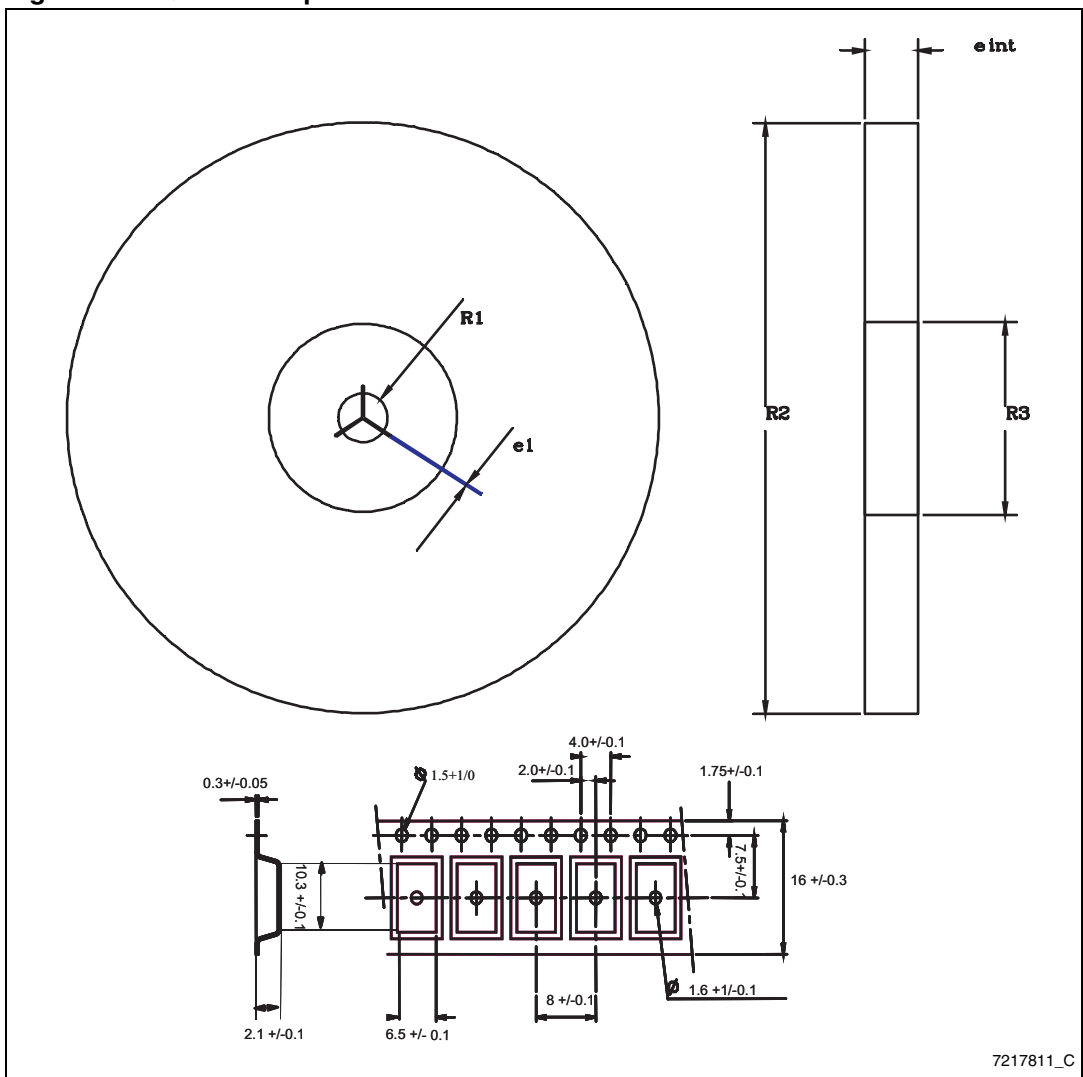

Table 17. TSSOP24 mechanical data

Dim.	mm.			Inches		
	Min	Typ	Max	Min	Typ	Max
A			1.1			0.043
A1	0.05		0.15	0.002		0.006
A2		0.9			0.035	
b	0.19		0.30	0.0075		0.0118
c	0.09		0.20	0.0035		0.0079
D	7.7		7.9	0.303		0.311
E	4.3		4.5	0.169		0.177
e		0.65 BSC			0.0256 BSC	
H	6.25		6.5	0.246		0.256
K	0°		8°	0°		8°
L	0.50		0.70	0.020		0.028

Figure 26. TSSOP24 package dimensions

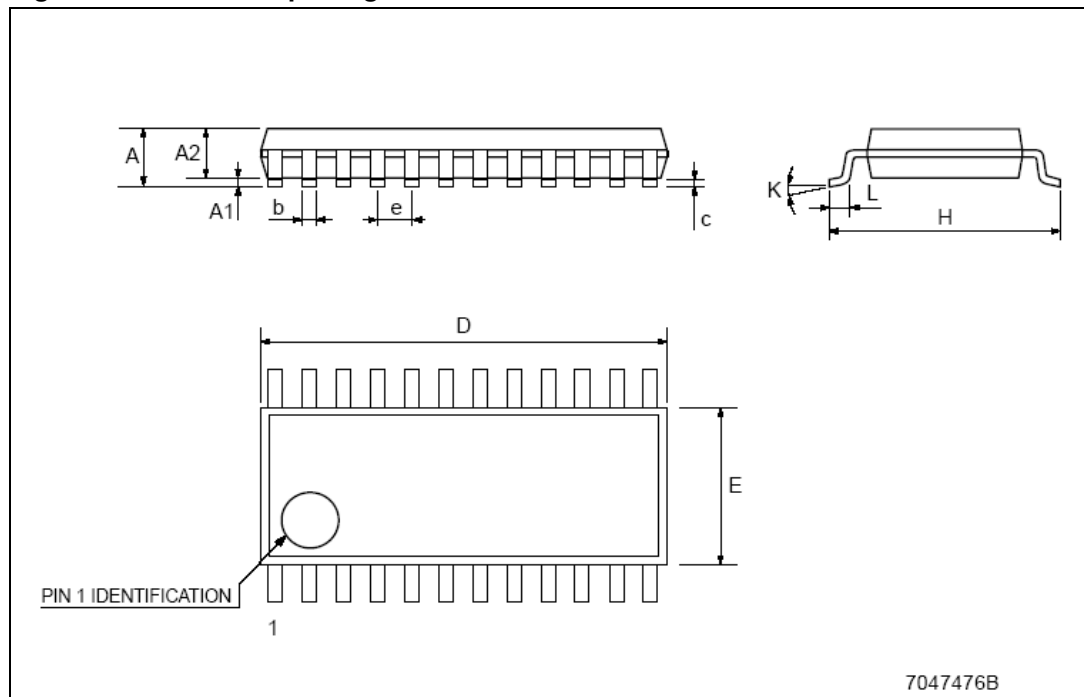

Table 18. TSSOP24 exposed pad mechanical data

Dim.	mm			Inches		
	Min	Typ	Max	Min	Typ	Max
A			1.2			0.047
A1			0.15		0.004	0.006
A2	0.8	1	1.05	0.031	0.039	0.041
b	0.19		0.30	0.007		0.012
c	0.09		0.20	0.004		0.0089
D	7.7	7.8	7.9	0.303	0.307	0.311
D1	4.7	5.0	5.3	0.185	0.197	0.209
E	6.2	6.4	6.6	0.244	0.252	0.260
E1	4.3	4.4	4.5	0.169	0.173	0.177
E2	2.9	3.2	3.5	0.114	0.126	0.138
e		0.65			0.0256	
K	0°		8°	0°		8°
L	0.45	0.60	0.75	0.018	0.024	0.030

Figure 27. TSSOP24 exposed pad dimensions

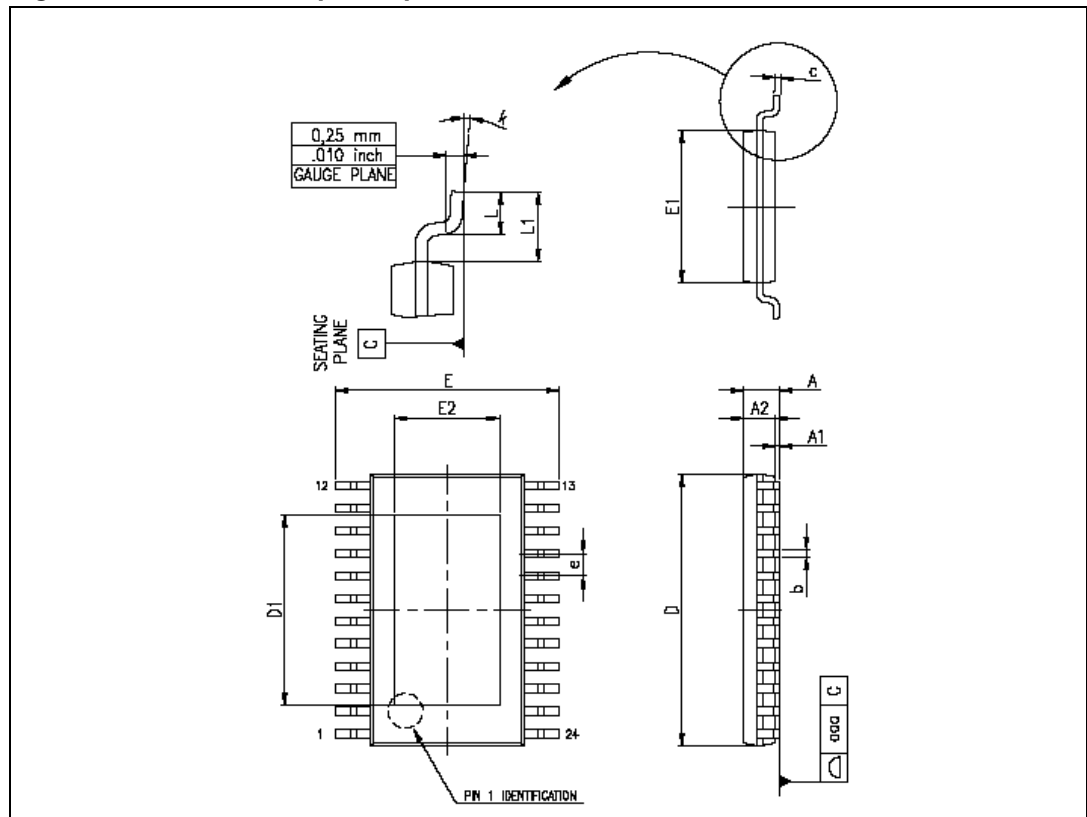

Table 19. Tape and reel TSSOP24 and TSSOP24 exposed pad

Dim.	mm.			Inches		
	Min	Typ	Max	Min	Typ	Max
A			330			12.992
C	12.8		13.2	0.504		0.519
D	20.2			0.795		
N	60			2.362		
T			22.4			0.882
Ao	6.8		7	0.268		0.276
Bo	8.2		8.4	0.323		0.331
Ko	1.7		1.9	0.067		0.075
Po	3.9		4.1	0.153		0.161
P	11.9		12.1	0.468		0.476

Figure 28. TSSOP24 and TSSOP24 exposed pad tape and reel dimensions

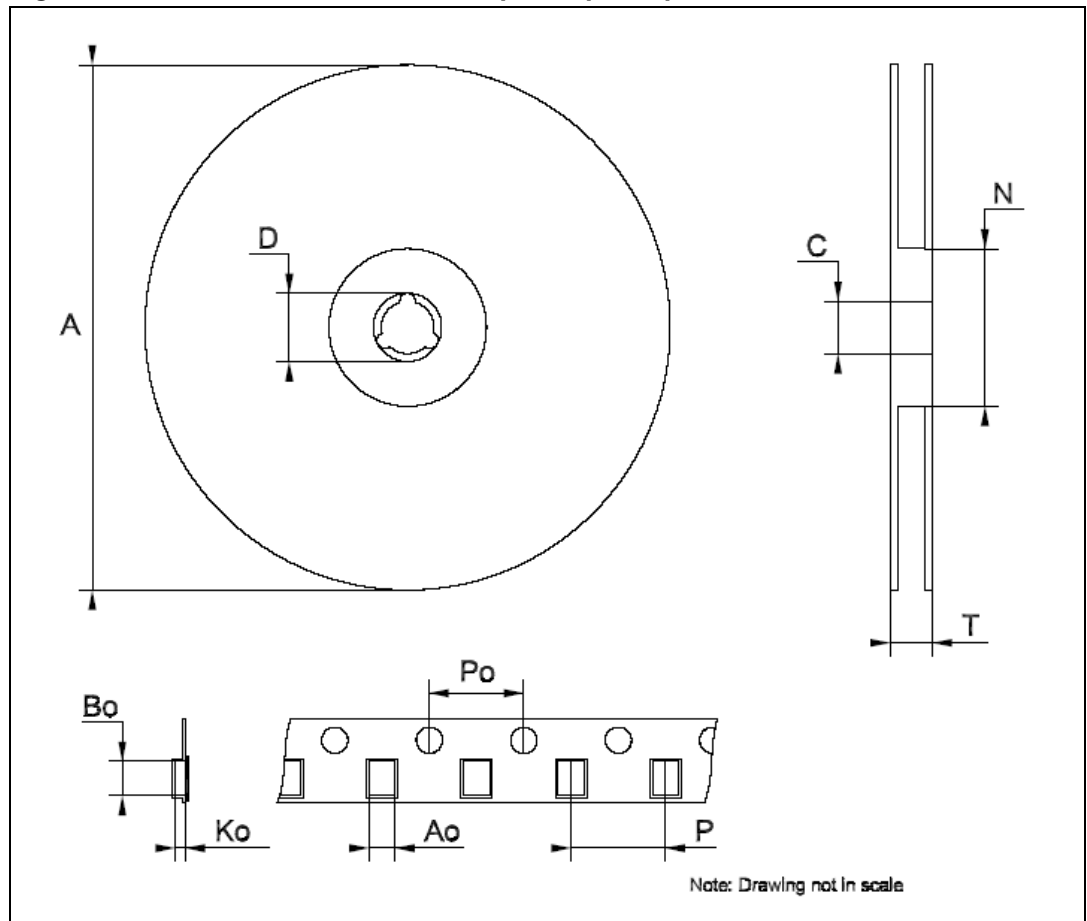
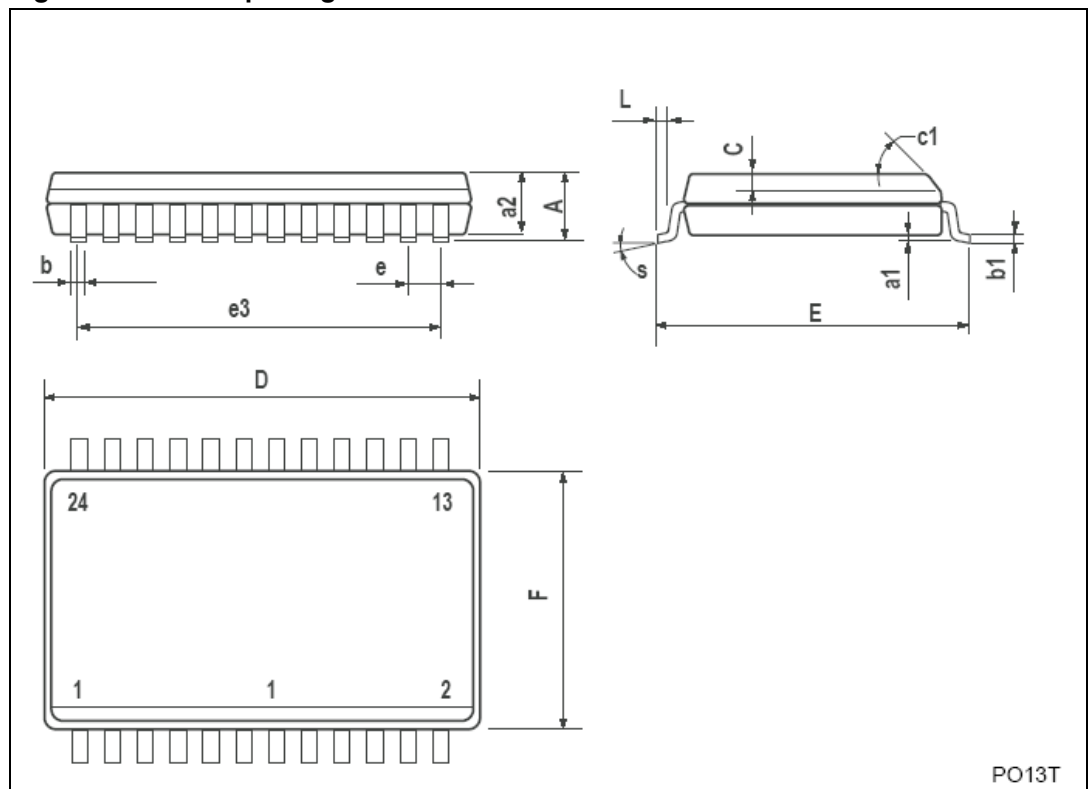

Table 20. SO-24 mechanical data

Dim.	mm.			Inches		
	Min	Typ	Max	Min	Typ	Max
A			2.65			0.104
a1	0.1		0.2	0.004		0.008
a2			2.45			0.096
b	0.35		0.49	0.014		0.019
b1	0.23		0.32	0.009		0.012
C		0.5			0.020	
c1	45°(typ.)					
D	15.20		15.60	0.598		0.614
E	10.00		10.65	0.393		0.419
e		1.27			0.050	
e3		13.97			0.550	
F	7.40		7.60	0.291		0.300
L	0.50		1.27	0.020		0.050
S	°(max.) 8					

Figure 29. SO-24 package dimensions



PO13T

Table 21. Tape and reel SO-24

Dim.	mm.			Inches		
	Min	Typ	Max	Min	Typ	Max
A			330			12.992
C	12.8		13.2	0.504		0.519
D	20.2			0.795		
N	60			2.362		
T			30.4			1.197
Ao	10.8		11.0	0.425		0.433
Bo	15.7		15.9	0.618		0.626
Ko	2.9		3.1	0.114		0.122
Po	3.9		4.1	0.153		0.161
P	11.9		12.1	0.468		0.476

Figure 30. SO-24 tape and reel dimensions

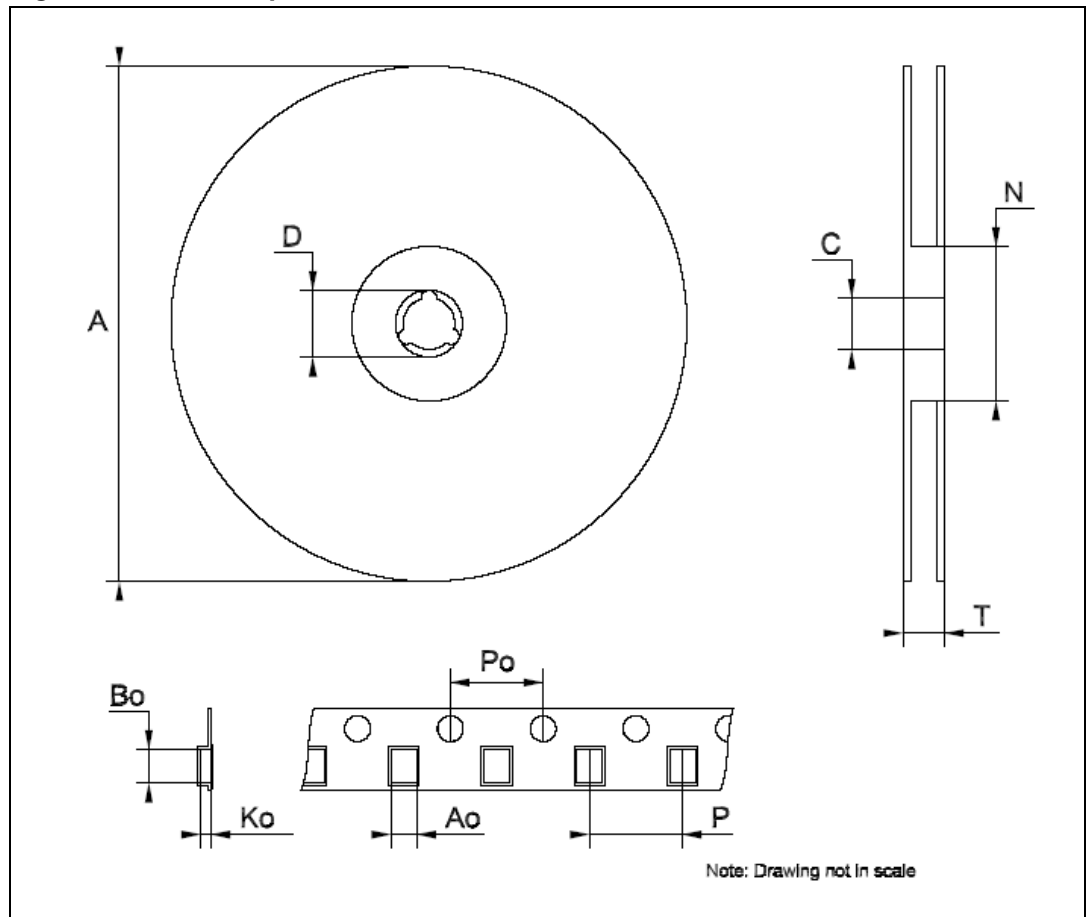

9 Revision history

Table 22. Document revision history

Date	Revision	Changes
22-Oct-2009	1	Initial release.

Please Read Carefully:

Information in this document is provided solely in connection with ST products. STMicroelectronics NV and its subsidiaries ("ST") reserve the right to make changes, corrections, modifications or improvements, to this document, and the products and services described herein at any time, without notice.

All ST products are sold pursuant to ST's terms and conditions of sale.

Purchasers are solely responsible for the choice, selection and use of the ST products and services described herein, and ST assumes no liability whatsoever relating to the choice, selection or use of the ST products and services described herein.

No license, express or implied, by estoppel or otherwise, to any intellectual property rights is granted under this document. If any part of this document refers to any third party products or services it shall not be deemed a license grant by ST for the use of such third party products or services, or any intellectual property contained therein or considered as a warranty covering the use in any manner whatsoever of such third party products or services or any intellectual property contained therein.

UNLESS OTHERWISE SET FORTH IN ST'S TERMS AND CONDITIONS OF SALE ST DISCLAIMS ANY EXPRESS OR IMPLIED WARRANTY WITH RESPECT TO THE USE AND/OR SALE OF ST PRODUCTS INCLUDING WITHOUT LIMITATION IMPLIED WARRANTIES OF MERCHANTABILITY, FITNESS FOR A PARTICULAR PURPOSE (AND THEIR EQUIVALENTS UNDER THE LAWS OF ANY JURISDICTION), OR INFRINGEMENT OF ANY PATENT, COPYRIGHT OR OTHER INTELLECTUAL PROPERTY RIGHT.

UNLESS EXPRESSLY APPROVED IN WRITING BY AN AUTHORIZED ST REPRESENTATIVE, ST PRODUCTS ARE NOT RECOMMENDED, AUTHORIZED OR WARRANTED FOR USE IN MILITARY, AIR CRAFT, SPACE, LIFE SAVING, OR LIFE SUSTAINING APPLICATIONS, NOR IN PRODUCTS OR SYSTEMS WHERE FAILURE OR MALFUNCTION MAY RESULT IN PERSONAL INJURY, DEATH, OR SEVERE PROPERTY OR ENVIRONMENTAL DAMAGE. ST PRODUCTS WHICH ARE NOT SPECIFIED AS "AUTOMOTIVE GRADE" MAY ONLY BE USED IN AUTOMOTIVE APPLICATIONS AT USER'S OWN RISK.

Resale of ST products with provisions different from the statements and/or technical features set forth in this document shall immediately void any warranty granted by ST for the ST product or service described herein and shall not create or extend in any manner whatsoever, any liability of ST.

ST and the ST logo are trademarks or registered trademarks of ST in various countries.

Information in this document supersedes and replaces all information previously supplied.

The ST logo is a registered trademark of STMicroelectronics. All other names are the property of their respective owners.

© 2009 STMicroelectronics - All rights reserved

STMicroelectronics group of companies

Australia - Belgium - Brazil - Canada - China - Czech Republic - Finland - France - Germany - Hong Kong - India - Israel - Italy - Japan - Malaysia - Malta - Morocco - Philippines - Singapore - Spain - Sweden - Switzerland - United Kingdom - United States of America

www.st.com