

Single buffer/driver with open drain

Features

- 5 V tolerant inputs
- High speed: $t_{PD} = 4.2$ ns (max.) at $V_{CC} = 3.3$ V
- Low power dissipation:
 - $I_{CC} = 1$ μ A (max.) at $T_A = 25$ °C
- Power down protection on inputs and outputs
- Operating voltage range:
 - $V_{CC} (opr) = 1.65$ to 5.5 V
- Latch-up performance exceeds 300 mA (JESD 17)
- ESD performance
 - 2000-V human body model (JESD 22 A114-A)
 - 200-V machine model (JESD 22 A115-A)
 - 1000-V charge device model (JESD 22 C101)

Applications

- Mobile phones

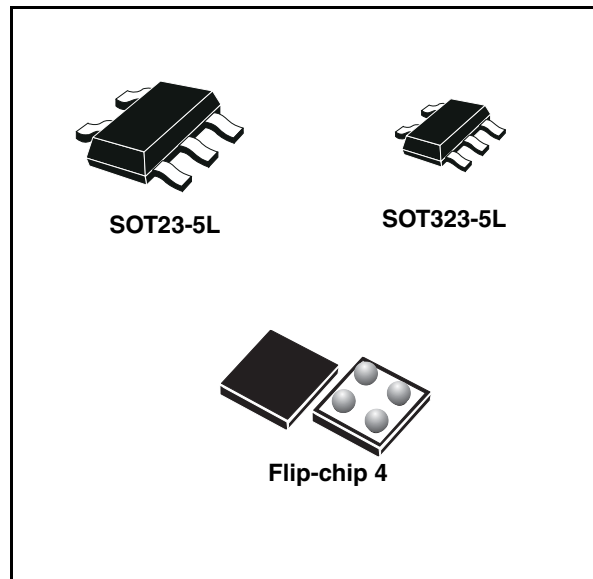

Description

The 74LX1G07 is a low voltage CMOS single buffer/driver (open drain) fabricated with sub-micron silicon gate and double-layer metal wiring C²MOS technology.

The internal circuit composed of 2 stages including buffer output, provides high noise immunity and stable output.

Power down protection is provided on input and 0 to 7 V can be accepted on input with no regards to the supply voltage. This device can be used to interface 5 to 3 V.

Table 1. Device summary

Order code	Package	Packaging
74LX1G07STR	SOT23-5L	Tape and reel
74LX1G07CTR	SOT323-5L	Tape and reel
74LX1G07BJR	Flip-chip 4	Tape and reel

Contents

1	Pin connection	3
2	Maximum rating	5
	2.1 Recommended operating conditions	6
3	Electrical characteristics	7
4	Package mechanical data	10
5	Revision history	18

1 Pin connection

Figure 1. Pin connection and IEC symbols

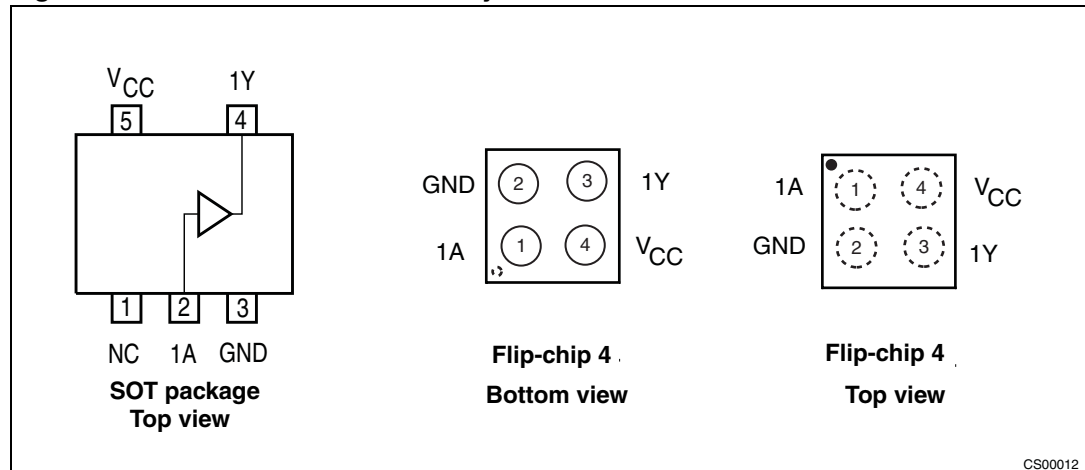

Table 2. Pin assignments

Pin number		Symbol	Name and function
Flip-chip 4	SOT		
—	1	NC	No connection
1	2	1A	Data input
3	4	1Y	Data output
2	3	GND	Ground (0V)
4	5	V _{CC}	Positive supply voltage

Table 3. Truth table

A	Y
L	L
H	Z

Z: High impedance

Figure 2. Input and output equivalent circuit

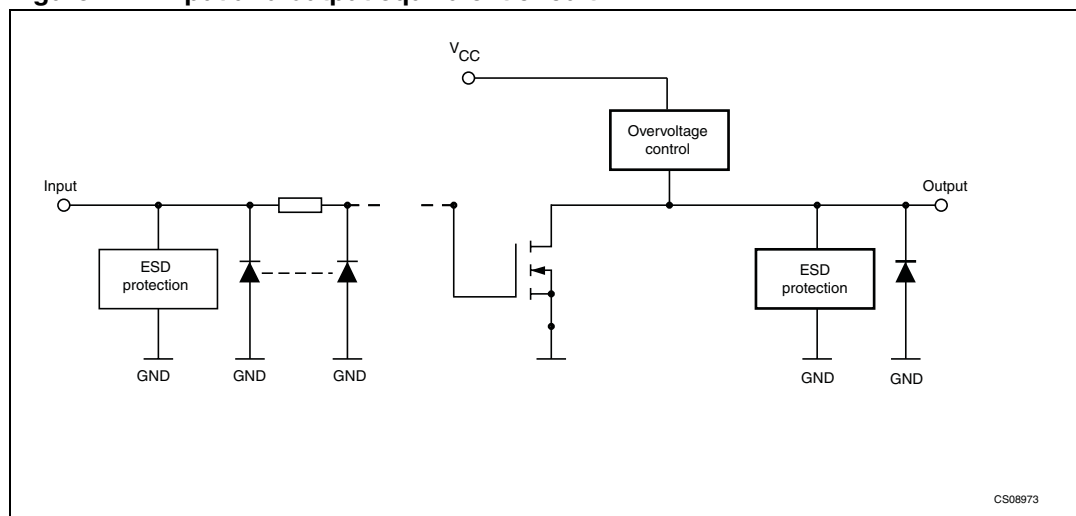

2 Maximum rating

Stressing the device above the rating listed in the “Absolute maximum ratings” table may cause permanent damage to the device. These are stress ratings only and operation of the device at these or any other conditions above those indicated in the operating sections of this specification is not implied. Exposure to absolute maximum rating conditions for extended periods may affect device reliability. Refer also to the STMicroelectronics SURE Program and other relevant quality documents.

Table 4. Absolute maximum ratings

Symbol	Parameter	Value	Unit
V_{CC}	Supply voltage	-0.5 to +7.0	V
V_I	DC input voltage	-0.5 to +7.0	V
V_O	DC output voltage ($V_{CC} = 0$ V)	-0.5 to +7.0	V
V_O	DC output voltage (high or low state)	-0.5 to $V_{CC} + 0.5$	V
I_{IK}	DC input diode current	- 50	mA
I_{OK}	DC output diode current	- 50	mA
I_O	DC output current	± 50	mA
I_{CC}	DC supply current per supply pin	± 100	mA
I_{GND}	DC ground current per supply pin	± 100	mA
T_{stg}	Storage temperature	-65 to +150	°C
T_L	Lead temperature (10 sec)	300	°C

2.1 Recommended operating conditions

Table 5. Recommended operating conditions

Symbol	Parameter	Value	Unit
V_{CC}	Supply voltage	1.65 to 5.5	V
V_I	Input voltage	0 to 5.5	V
V_O	Output voltage ($V_{CC} = 0$ V)	0 to 5.5	V
V_O	Output voltage (high or low state)	0 to V_{CC}	V
I_{OL}	High or low level output current ($V_{CC} = 4.5$ to 5.5 V)	+ 32	mA
I_{OL}	High or low level output current ($V_{CC} = 3.0$ to 3.6 V)	+24	mA
I_{OL}	High or low level output current ($V_{CC} = 2.7$ to 3.0 V)	+12	mA
I_{OL}	High or low level output current ($V_{CC} = 2.3$ to 2.7 V)	+8	mA
I_{OL}	High or low level output current ($V_{CC} = 1.65$ to 2.3 V)	+4	mA
T_{op}	Operating temperature	-40 to 85	°C
dt/dv	Input rise and fall time	0 to 10	ns/V

3 Electrical characteristics

Table 6. DC specifications

Symbol	Parameter	Test condition		Value		Unit
		V _{CC} (V)		-40 to 85 °C		
				Min	Max	
V _{IH}	High level input voltage	1.65 – 1.95		0.65 V _{CC}		V
		2.3 – 2.7		0.7 V _{CC}		
		3.0 – 5.5		0.7 V _{CC}		
V _{IL}	Low level input voltage	1.65 – 1.95			0.35 V _{CC}	V
		2.3 – 2.7			0.3 V _{CC}	
		3.0 – 5.5			0.3 V _{CC}	
V _{OL}	Low level output voltage	1.65 – 4.5	I _O = 100 μA		0.1	V
		1.65	I _O = 4 mA		0.45	
		2.3	I _O = 8 mA		0.3	
		3.0	I _O = 16 mA		0.4	
			I _O = 24 mA		0.55	
		4.5	I _O = 32 mA		0.55	
I _{OZ}	High impedance output leakage current	3.6	V _I = 5.5 V		±10	μA
I _I	Input leakage current	1.65 – 5.5	V _I = 0 – 5.5 V		±5	μA
I _{off}	Power off leakage current	0	V _I or V _O = 5.5 V		10	μA
I _{CC}	Quiescent supply current	1.65 – 5.5	V _I = V _{CC} or GND		10	μA
		3.6	V _I or V _O = 3.6 to 5.5 V		±10	

Table 7. AC electrical characteristics

Symbol	Parameter	Test conditions				Value		Unit
		V _{CC} (V)	C _L (pF)	R ₁ (Ω)	t _s = t _r (ns)	-40 to 85 °C		
						Min	Max	
t _{PLZ}	Propagation delay time	1.65 – 1.95	30	1000	2.0	1.8	8.3	ns
		2.3 – 2.7	30	500	2.0	1.2	5.5	
		2.7	50	500	2.5	1	5	
		3.0 – 3.6	50	500	2.5	0.8	4.2	
		4.5 – 5.5	50	500	2.5	0.5	3.5	
t _{PZL}	Propagation delay time	1.65 – 1.95	30	1000	2.0	1.8	8.3	ns
		2.3 – 2.7	30	500	2.0	1.2	5.5	
		2.7	50	500	2.5	1	5	
		3.0 – 3.6	50	500	2.5	0.8	4.2	
		4.5 – 5.5	50	500	2.5	0.5	3.5	

Table 8. Capacitive characteristics

Symbol	Parameter	Test conditions		Value			Unit
		V _{CC} (V)		T _A = 25 °C			
				Min	Typ	Max	
C _{IN}	Input capacitance	3.3	V _{IN} = 0 or V _{CC}		2.5		pF
C _{OUT}	Output capacitance	3.3	V _{IN} = 0 or V _{CC}		4		pF
C _{PD}	Power dissipation capacitance ⁽¹⁾	1.8	f _{IN} = 10 MHz		8		pF
		2.5			8		
		3.3			8		

1. C_{PD} is defined as the value of the IC's internal equivalent capacitance which is calculated from the operating current consumption without load. (Refer to test circuit). Average operating current can be obtained by the following equation: I_{CC(opr)} = C_{PD} × V_{CC} × f_{IN} + I_{CC}

Figure 3. Test circuit

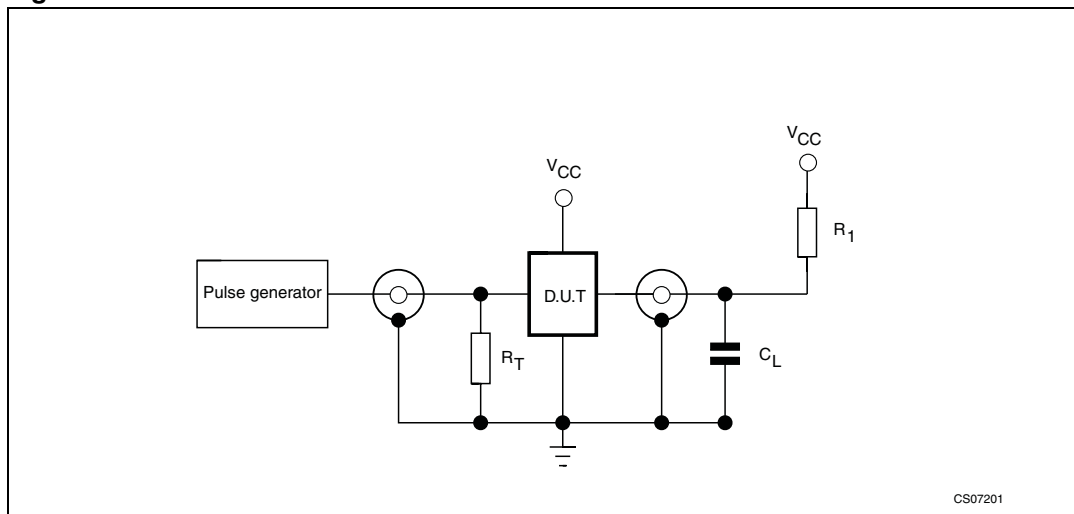
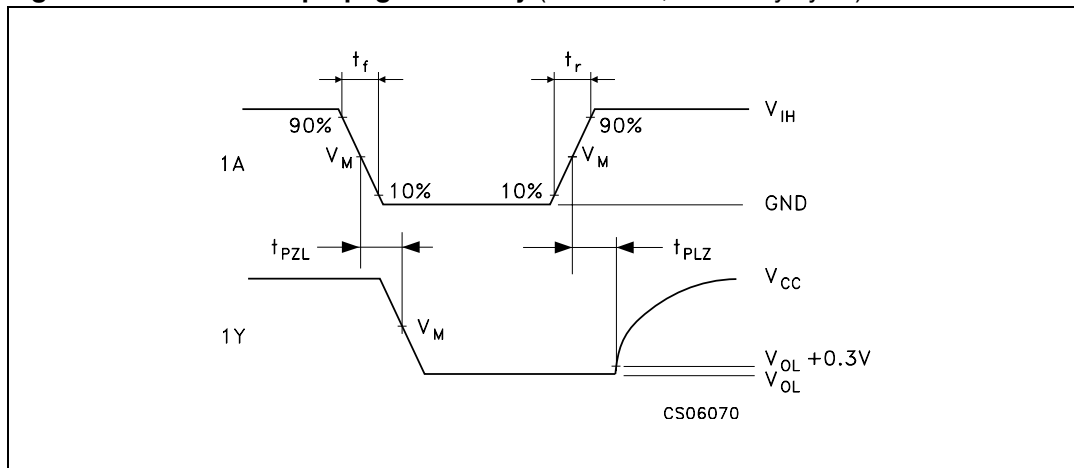

Table 9. Test circuit and waveform symbol value

Symbol	V _{CC}		
	1.65 – 1.95 V	2.3 – 2.7 V	2.7 – 5.5 V
C _L	30 pF	30 pF/ 50 pF	50 pF
R1	1000 Ω	500 Ω	500 Ω
V _{IH}	V _{CC}	V _{CC}	V _{CC}
V _M	V _{CC} /2	V _{CC} /2	V _{CC} /2
t _r = t _f	< 2.0 ns	< 2.0 ns	< 2.5 ns

Figure 4. Waveform: propagation delay (f = 1 MHz; 50% duty cycle)



4 Package mechanical data

In order to meet environmental requirements, ST offers these devices in ECOPACK[®] packages. These packages have a Lead-free second level interconnect. The category of second level interconnect is marked on the package and on the inner box label, in compliance with JEDEC standard JESD97. The maximum ratings related to soldering conditions are also marked on the inner box label. ECOPACK is an ST trademark. ECOPACK specifications are available at: www.st.com.

Figure 5. SOT23-5L package outline

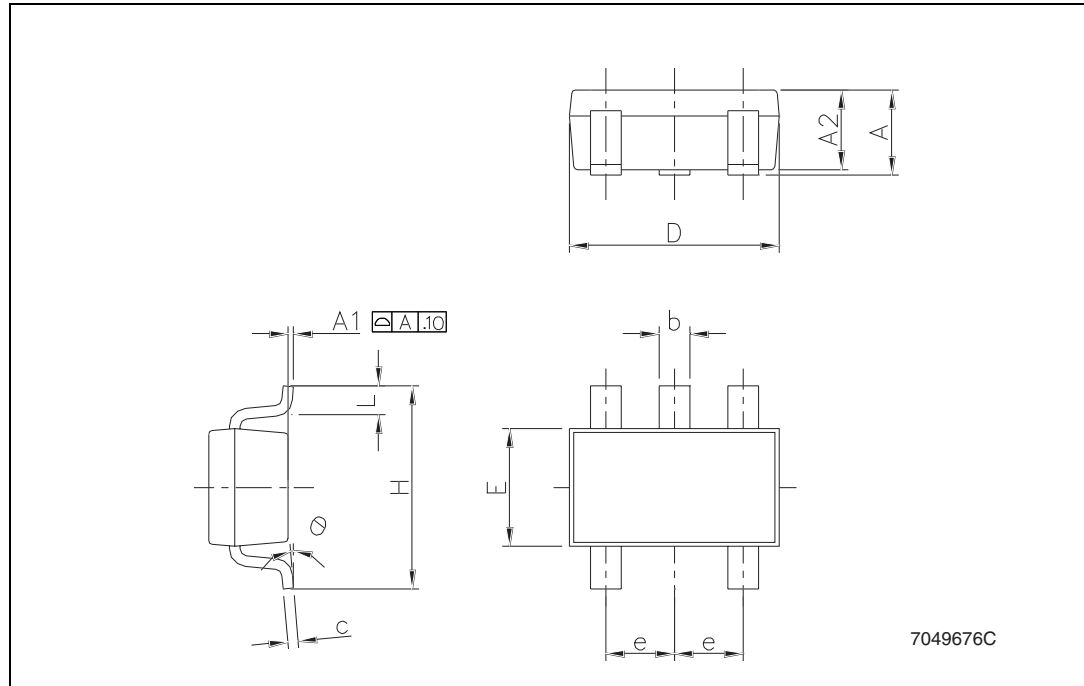

Table 10. SOT23-5L mechanical data

Symbol	millimeters			mils		
	Typ	Min	Max	Typ	Min	Max
A	0.90		1.45	35.4		57.1
A1	0.00		0.10	0.0		3.9
A2	0.90		1.30	35.4		51.2
b	0.35		0.50	13.7		19.7
C	0.09		0.20	3.5		7.8
D	2.80		3.00	110.2		118.1
E	1.50		1.75	59.0		68.8
e		0.95			37.4	
H	2.60		3.00	102.3		118.1
L	0.10		0.60	3.9		23.6

Figure 6. SOT323-5L package outline

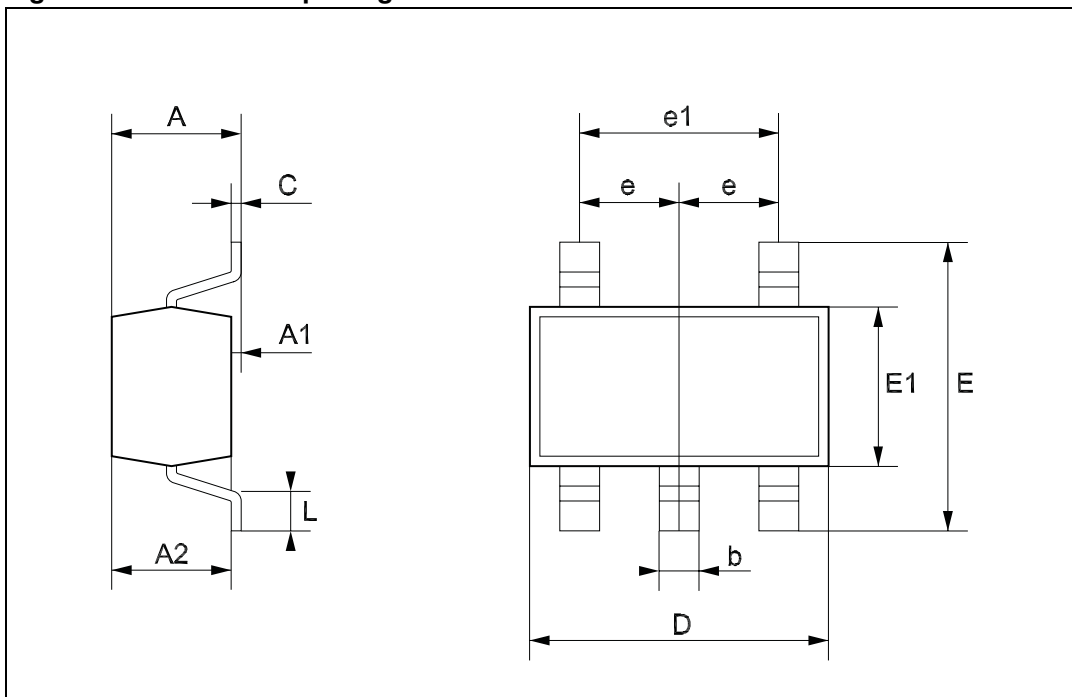

Table 11. SOT323-5L mechanical data

Symbol	millimeters			mils		
	Typ	Min	Max	Typ	Min	Max
A	0.80		1.10	31.5		43.3
A1	0.00		0.10	0.0		3.9
A2	0.80		1.00	31.5		39.4
b	0.15		0.30	5.9		11.8
C	0.10		0.18	3.9		7.1
D	1.80		2.20	70.9		86.6
E	1.80		2.20	70.9		94.5
E1	1.15		1.35	45.3		53.1
e		0.65			25.6	
e1		1.3			51.2	
L	0.10		0.30	3.9		11.8

Figure 7. Flip-chip 4 package outline

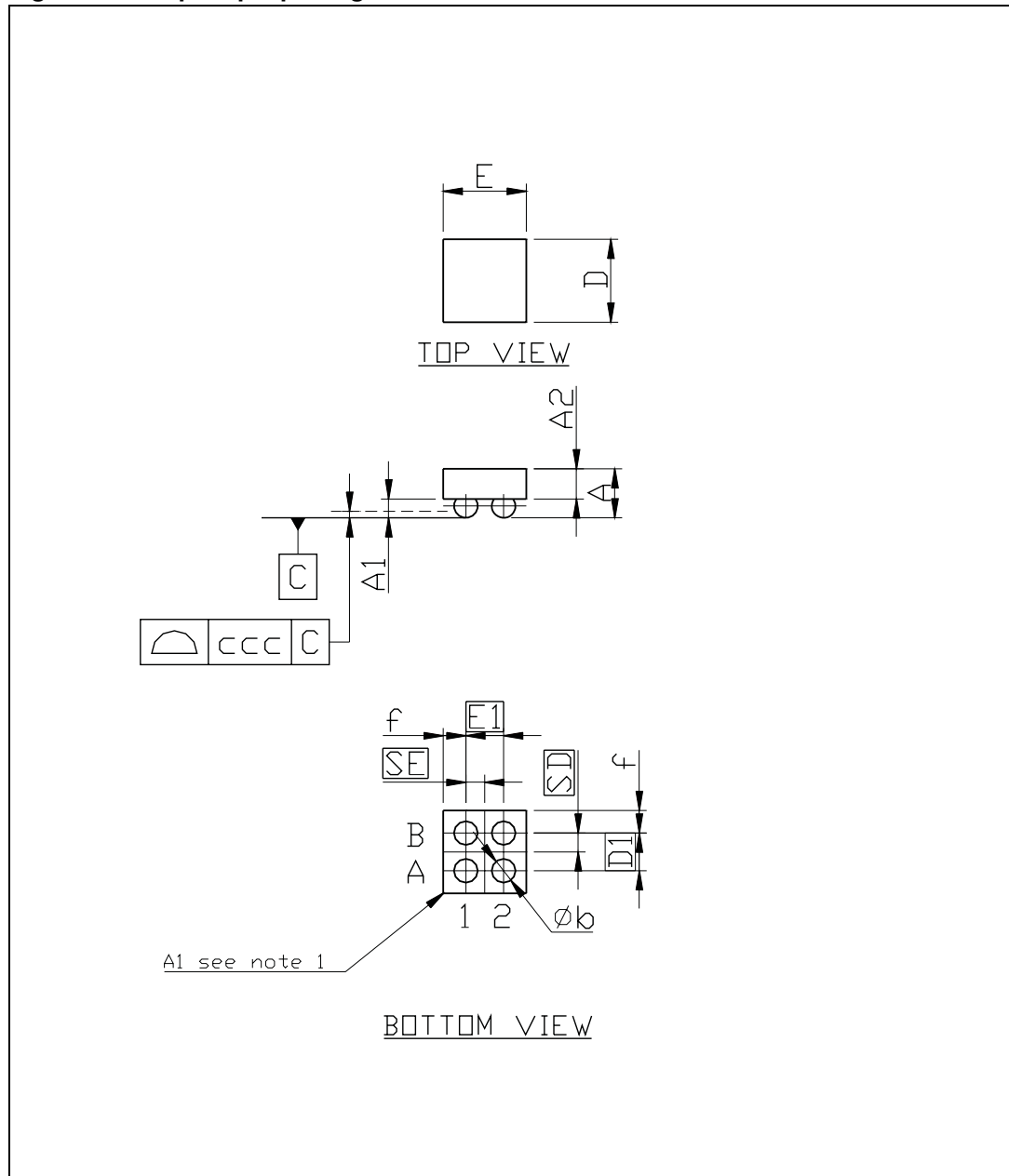

Table 12. Flip-chip 4 mechanical data

Symbol	millimeters		
	Min	Typ	Max
A	0.535	0.58	0.625
A1	0.18	0.205	0.23
A2	0.355	0.375	0.395
b	0.215	0.255	0.295
D	0.84	0.87	0.9
D1		0.5	
E	0.84	0.87	0.9
E1		0.5	
SD		0.25	
SE		0.25	
f	0.175	0.185	0.195
ccc		0.080	

Figure 8. Flip-chip 4 recommended footprint

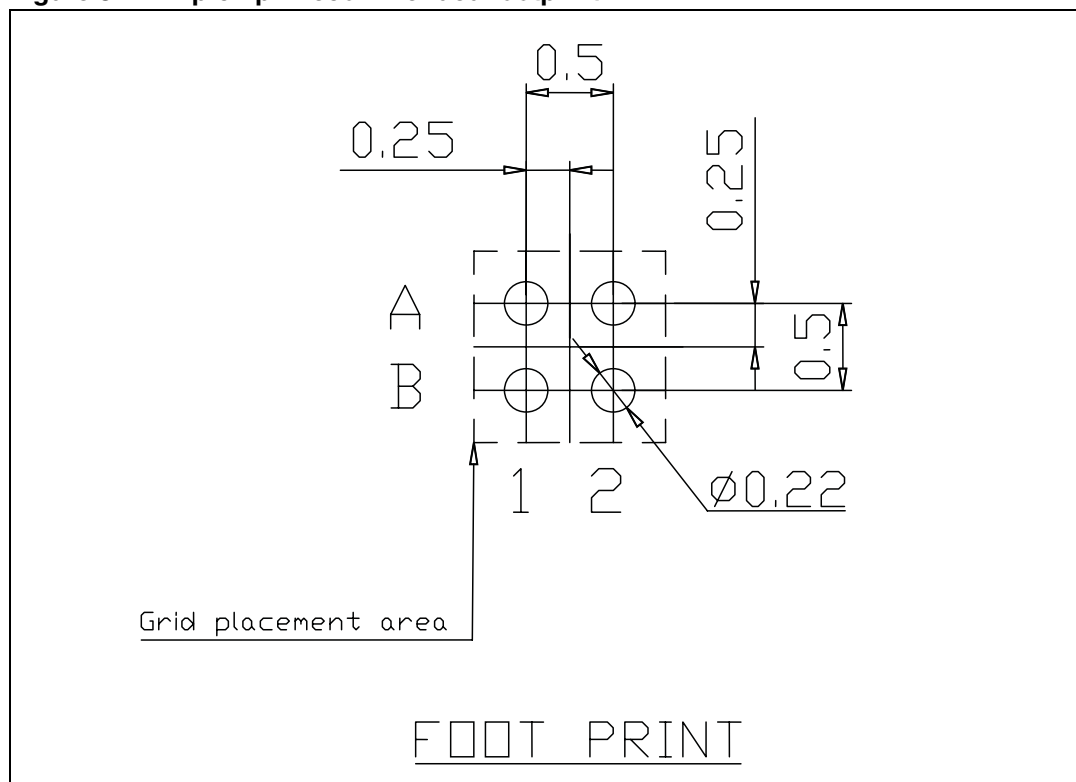

Figure 9. SOT23-xL tape and reel

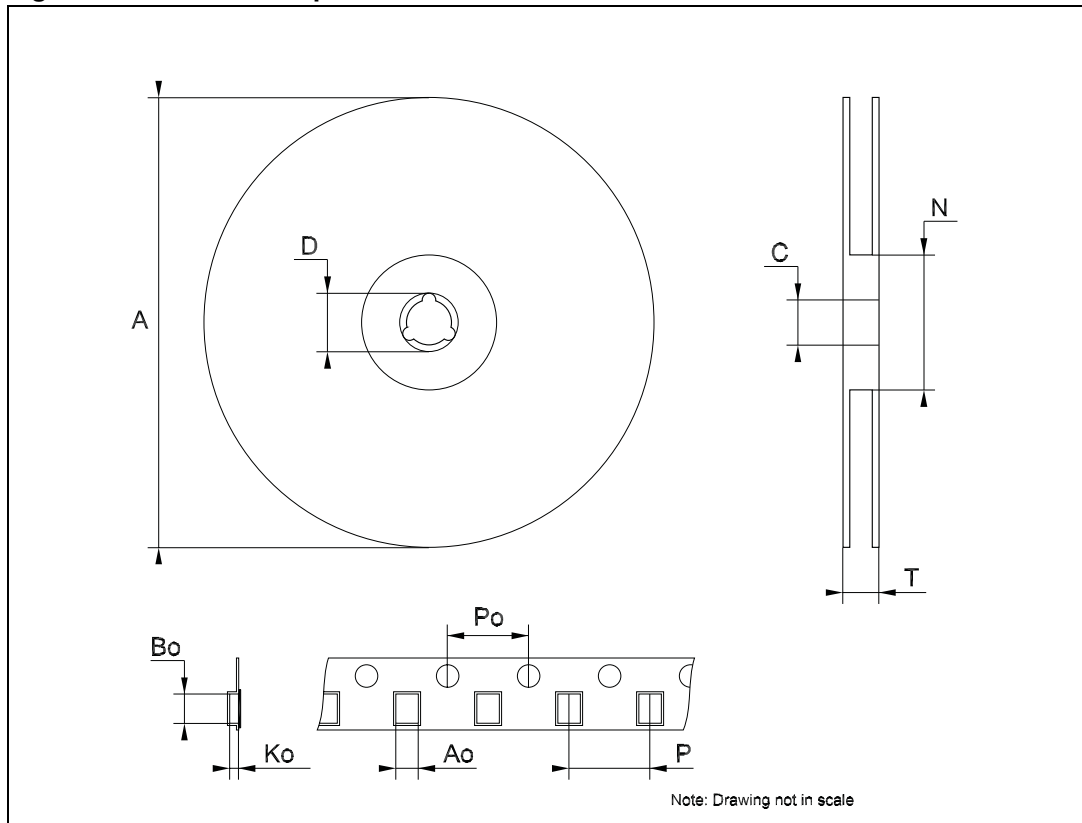
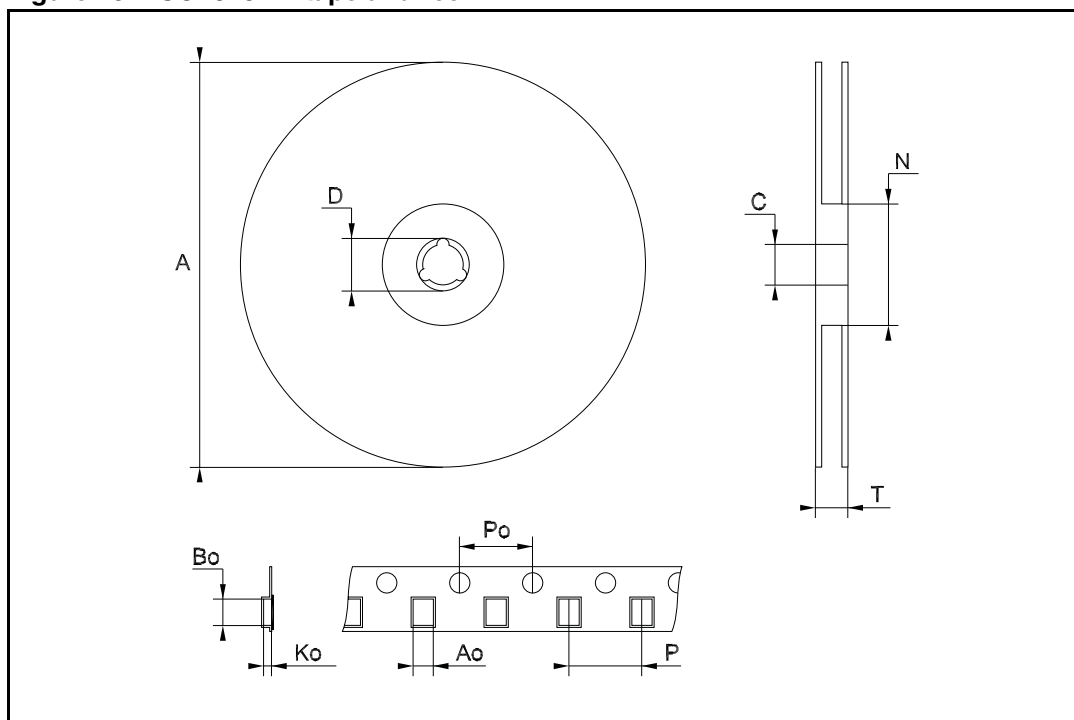

Table 13. SOT23-xL tape and reel mechanical data

Symbol	millimeters			inches		
	Typ	Min	Max	Typ	Min	Max
A			180			7.086
C	12.8	13.0	13.2	0.504	0.512	0.519
D	20.2			0.795		
N	60			2.362		
T			14.4			0.567
Ao	3.13	3.23	3.33	0.123	0.127	0.131
Bo	3.07	3.17	3.27	0.120	0.124	0.128
Ko	1.27	1.37	1.47	0.050	0.054	0.058
Po	3.9	4.0	4.1	0.153	0.157	0.161
P	3.9	4.0	4.1	0.153	0.157	0.161

Figure 10. SOT323-xL tape and reel



1. Drawing not to scale.

Table 14. SOT323-xL tape and reel mechanical data

Symbol	millimeters			inches		
	Typ	Min	Max	Typ	Min	Max
A	175	180	185	6.889	7.086	7.283
C	12.8	13	13.2	0.504	0.512	0.519
D	20.2			0.795		
N	59.5	60	60.5		2.362	
T			14.4			0.567
Ao		2.25			0.088	
Bo		2.7			0.106	
Ko		1.2			0.047	
Po	3.9	4	4.1	0.153	0.157	0.161
P	3.8	4	4.2	0.149	0.157	0.165

Figure 11. Flip-chip 4 reel information - back side

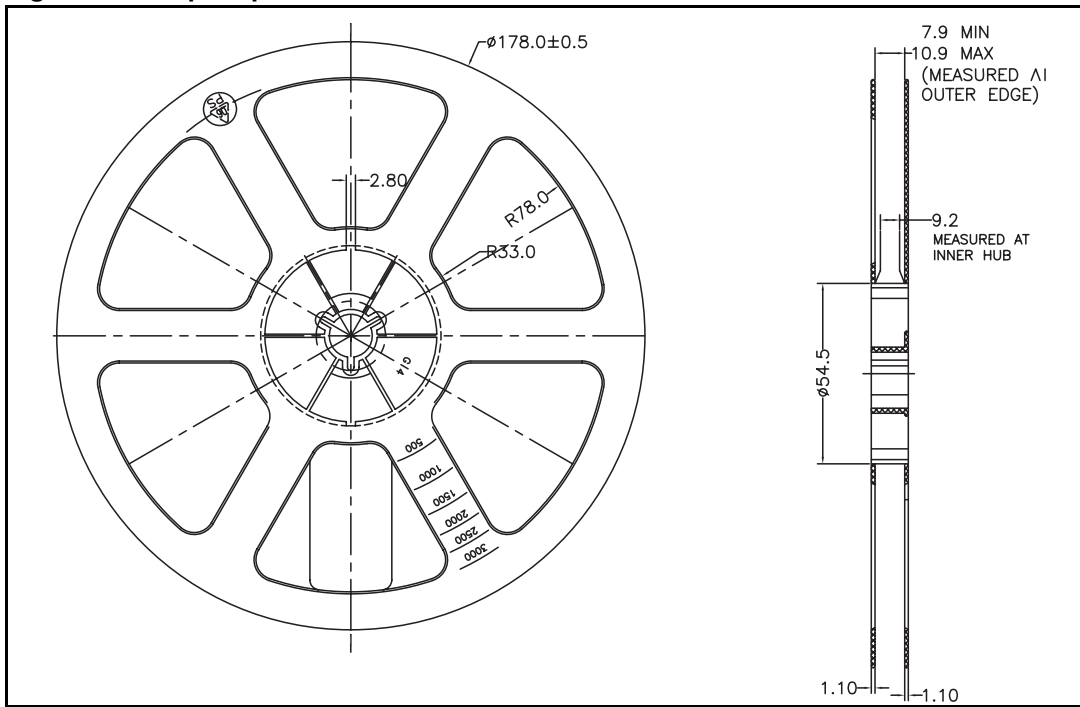

Figure 12. Flip-chip 4 reel information - front side

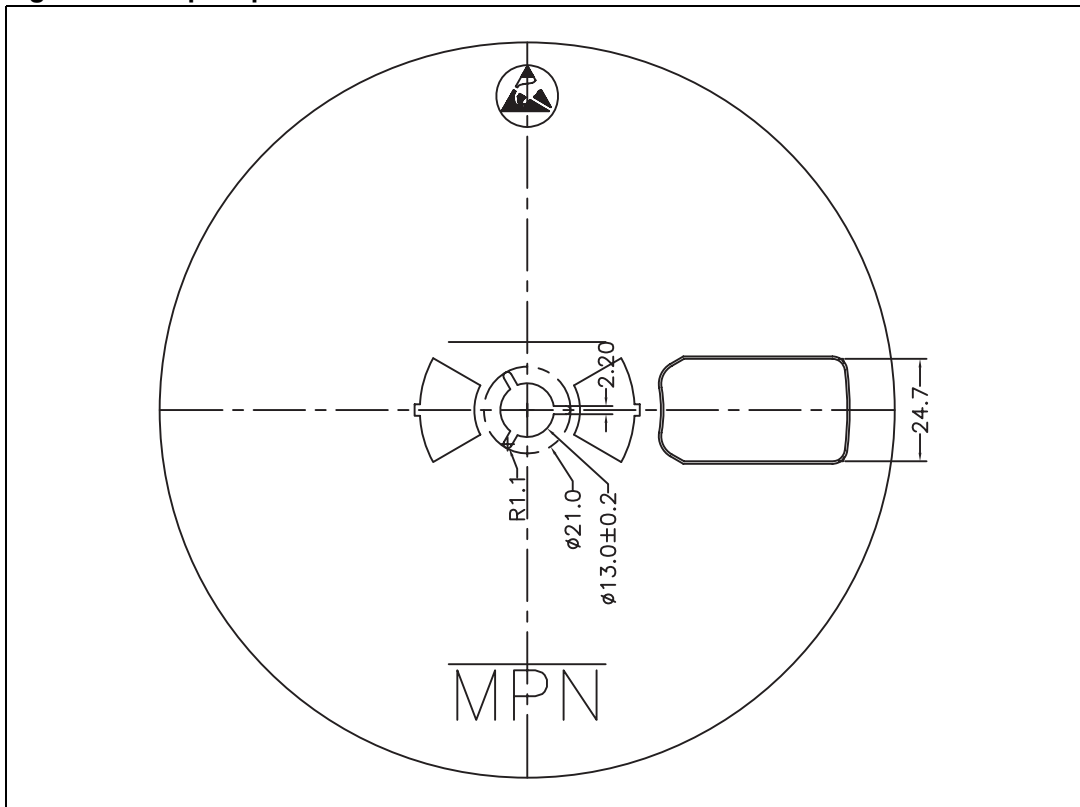

Figure 13. Flip-chip 4 carrier tape information

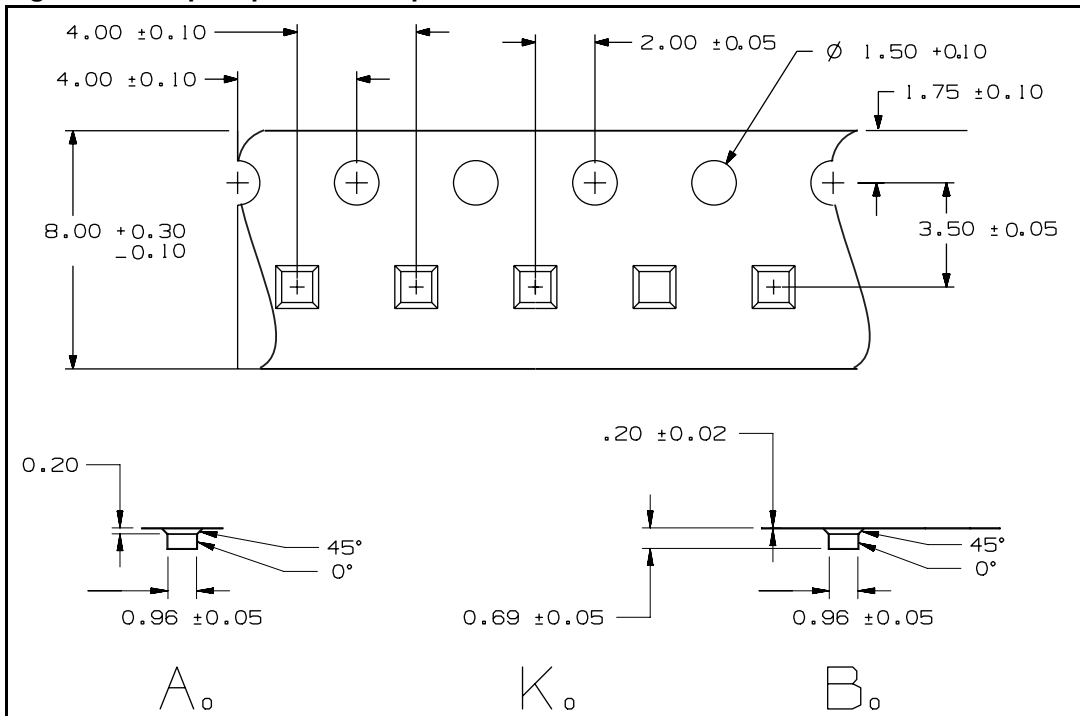
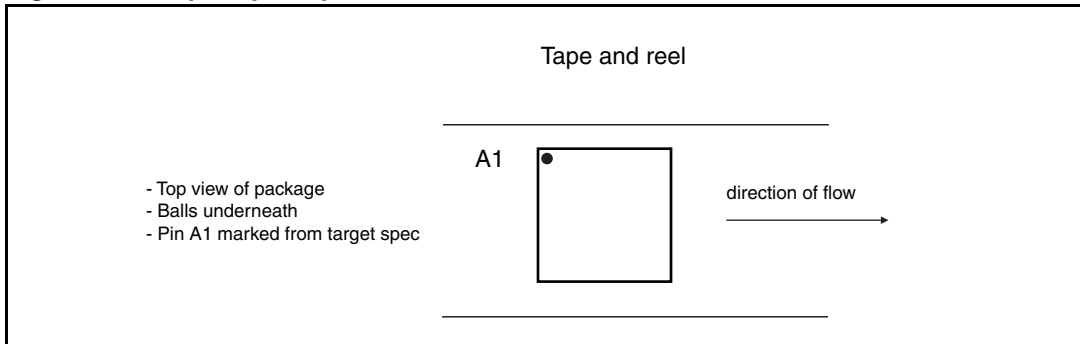

Figure 14. Flip-chip 4 tape orientation



5 Revision history

Table 15. Document revision history

Date	Revision	Changes
04-Sept-2004	4	Document change.
03-May-2006	5	Data reel updating.
17-Jan-2008	6	Document restructured and converted to new ST template. Added 74LX1G07BJR and related package information.
29-Jan-2008	7	Flip-Chip 4 replaced with Flip-chip 4 and updated Table 12 on page 13 .
21-Feb-2008	8	Replaced Flip-Chip 4 package name with Flip-chip 4, latch-up and ESD performance among the specifications in the cover page and updated Table 6 on page 7 , Table 8 on page 8 , and Table 12 on page 13 , replaced Figure 13 on page 18 and Figure 14 on page 18
23-Apr-2008	9	Modified: Table 12 on page 13 and Figure 13 on page 18 .

Please Read Carefully:

Information in this document is provided solely in connection with ST products. STMicroelectronics NV and its subsidiaries ("ST") reserve the right to make changes, corrections, modifications or improvements, to this document, and the products and services described herein at any time, without notice.

All ST products are sold pursuant to ST's terms and conditions of sale.

Purchasers are solely responsible for the choice, selection and use of the ST products and services described herein, and ST assumes no liability whatsoever relating to the choice, selection or use of the ST products and services described herein.

No license, express or implied, by estoppel or otherwise, to any intellectual property rights is granted under this document. If any part of this document refers to any third party products or services it shall not be deemed a license grant by ST for the use of such third party products or services, or any intellectual property contained therein or considered as a warranty covering the use in any manner whatsoever of such third party products or services or any intellectual property contained therein.

UNLESS OTHERWISE SET FORTH IN ST'S TERMS AND CONDITIONS OF SALE ST DISCLAIMS ANY EXPRESS OR IMPLIED WARRANTY WITH RESPECT TO THE USE AND/OR SALE OF ST PRODUCTS INCLUDING WITHOUT LIMITATION IMPLIED WARRANTIES OF MERCHANTABILITY, FITNESS FOR A PARTICULAR PURPOSE (AND THEIR EQUIVALENTS UNDER THE LAWS OF ANY JURISDICTION), OR INFRINGEMENT OF ANY PATENT, COPYRIGHT OR OTHER INTELLECTUAL PROPERTY RIGHT.

UNLESS EXPRESSLY APPROVED IN WRITING BY AN AUTHORIZED ST REPRESENTATIVE, ST PRODUCTS ARE NOT RECOMMENDED, AUTHORIZED OR WARRANTED FOR USE IN MILITARY, AIR CRAFT, SPACE, LIFE SAVING, OR LIFE SUSTAINING APPLICATIONS, NOR IN PRODUCTS OR SYSTEMS WHERE FAILURE OR MALFUNCTION MAY RESULT IN PERSONAL INJURY, DEATH, OR SEVERE PROPERTY OR ENVIRONMENTAL DAMAGE. ST PRODUCTS WHICH ARE NOT SPECIFIED AS "AUTOMOTIVE GRADE" MAY ONLY BE USED IN AUTOMOTIVE APPLICATIONS AT USER'S OWN RISK.

Resale of ST products with provisions different from the statements and/or technical features set forth in this document shall immediately void any warranty granted by ST for the ST product or service described herein and shall not create or extend in any manner whatsoever, any liability of ST.

ST and the ST logo are trademarks or registered trademarks of ST in various countries.

Information in this document supersedes and replaces all information previously supplied.

The ST logo is a registered trademark of STMicroelectronics. All other names are the property of their respective owners.

© 2008 STMicroelectronics - All rights reserved

STMicroelectronics group of companies

Australia - Belgium - Brazil - Canada - China - Czech Republic - Finland - France - Germany - Hong Kong - India - Israel - Italy - Japan - Malaysia - Malta - Morocco - Singapore - Spain - Sweden - Switzerland - United Kingdom - United States of America

www.st.com