

**M3200 series**  
**H3200 series**  
**VCXO 5.0V**  
**Full/Half size, Thru-hole, HCMOS/TTL**

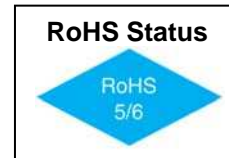

**Features**

- Super low jitter of 20 ps peak to peak
- Frequency from 3 MHz to 105 MHz
- APR to  $\pm 150$ ppm
- Start-up time is less than 5ms



**Applications**

- xDSL customer premise equipment
- Cable modems
- ATM/SONET/SDH

**Electrical Specifications**

Parameter	Symbol	Condition	Min	Typ	Max	Unit	Note
Frequency Range	F		3		105	MHz	
Frequency Stability	$\Delta F/F$	Operating Temperature at 25°C		$\pm 30$	$\pm 50$	ppm	
Aging		First Year After First Year		3 1		ppm ppm/yr	
Operating Temperature	T		0°		+70°	°C	
Supply Voltage	V <sub>cc</sub>		4.5	5.0	5.5	V	
Supply Current	I <sub>cc</sub>			30	45	mA	
Output Levels		"0" Level, sinking 16mA "1" Level, sourcing 10mA	V <sub>DD</sub> -0.4		0.4	V	
Rise & Fall Times		From 0.4 to (V <sub>DD</sub> -0.4) V (Above 35 MHz)		2.5	4 2	ns	
Peak Jitter	1 $\sigma$				20	ps	
Tristate		"1" Output is On – Pin 5 may float or 2.4V min, sourcing 400 $\mu$ a "0" Output is disabled, tristate, high impedance – Pin 5 requires 0.4V, sinking 400 $\mu$ a					
Input Impedance		Control voltage	15	1000		KOhm	
Start-up Time	T <sub>s</sub>				5	ms	
Symmetry		@ V <sub>DD</sub> /2			45/55	%	
Control Voltage Bandwidth			15	20		KHz	
APR			$\pm 50$	$\pm 75$	$\pm 150$	ppm	

**M3200 series**  
**H3200 series**  
**VCXO 5.0V**



**Full/Half size, Thru-hole, HCMOS/TTL**

**Environmental and Mechanical Conditions**

Parameter	Specification
Shock	1000 Gs, 0.35 ms, 1/2 sine wave, 3 shocks in each plane
Vibration	10-2000 Hz of .06" d.a. or 20 Gs, whichever is less
Humidity	Resistant to 85° R.H. at 85°C
Gross Leak	Each unit checked in 125°C fluorocarbon
Fine Leak	Mass spectrometer leak rate less than $2 \times 10^{-8}$ atm, cc/sec of helium
Pins	Kovar, nickel plated with 60/40 solder coat, or 7 microinch gold
Bend Test	Will withstand two bends of 90° from reference
Header	Steel, with nickel plate, or 7 microinch gold over nickel
Case	Stainless steel, type 304
Marking	Printing is black epoxy ink
Resistance to Solvents	MIL STD 202, Method 215

**Center Frequency is at 2.5V with ±50 ppm stability**

MODEL	Control Voltage (Volts)	Frequency Deviation (ppm)	Guaranteed Capture Range (ppm)	Control Voltage at Center Frequency	Center Frequency Stability (ppm)
3261	0.5 to 4.5	± 75 to 150	± 75	2.5	± 30, typ ± 50, max
3262	0.5 to 4.5	± 100 to 200	± 100	2.5	
3263	0.5 to 4.5	± 150 to 300	± 150	2.5	

**Center Frequency is at 2.5V with ±25 ppm stability**

MODEL	Control Voltage (Volts)	Frequency Deviation (ppm)	Guaranteed Capture Range (ppm)	Control Voltage at Center Frequency	Center Frequency Stability (ppm)
3271	0.5 to 4.5	± 75 to 150	± 75	2.5	± 20, typ ± 25, max
3272	0.5 to 4.5	± 100 to 200	± 100	2.5	
3273	0.5 to 4.5	± 150 to 300	± 150	2.5	

**Center Frequency is at 2.5V with ±20 ppm stability**

MODEL	Control Voltage (Volts)	Frequency Deviation (ppm)	Guaranteed Capture Range (ppm)	Control Voltage at Center Frequency	Center Frequency Stability (ppm)
3281	0.5 to 4.5	± 75 to 150	± 75	2.5	± 15, typ ± 20, max
3282	0.5 to 4.5	± 100 to 200	± 100	2.5	
3283	0.5 to 4.5	± 150 to 300	± 150	2.5	

**DESCRIPTIONS**

M3261, H3261	±75 ppm capture when using using 0.5 to 4.5V control-voltage and 2.5V center with ±50 ppm stability
M3262, H3262	±100 ppm capture when using using 0.5 to 4.5V control-voltage and 2.5V center with ±50 ppm stability
M3263, H3263	±150 ppm capture when using using 0.5 to 4.5V control-voltage and 2.5V center with ±50 ppm stability
M3271, H3271	±75 ppm capture when using using 0.5 to 4.5V control-voltage and 2.5V center with ±25 ppm stability
M3272, H3272	±100 ppm capture when using using 0.5 to 4.5V control-voltage and 2.5V center with ±25 ppm stability
M3273, H3273	±150 ppm capture when using using 0.5 to 4.5V control-voltage and 2.5V center with ±25 ppm stability
M3281, H3281	±75 ppm capture when using using 0.5 to 4.5V control-voltage and 2.5V center with ±20 ppm stability
M3282, H3282	±100 ppm capture when using using 0.5 to 4.5V control-voltage and 2.5V center with ±20 ppm stability
M3283, H3283	±150 ppm capture when using using 0.5 to 4.5V control-voltage and 2.5V center with ±20 ppm stability



**M3200 series**  
**H3200 series**  
**VCXO 5.0V**



**Full/Half size, Thru-hole, HCMOS/TTL**

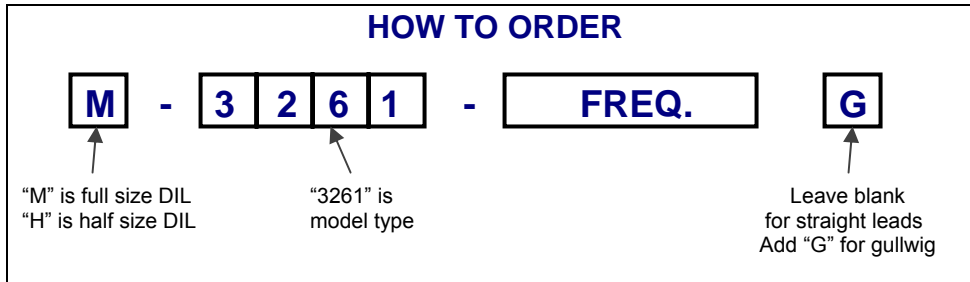

Pin #	Full size (M)	Half size (H)
1	N/C	Control Voltage
2	Control Voltage	Tristate
4	N/C	Ground & Case
5	Tristate	Output
7	Ground & Case	N/C
8	Output	+5V, V <sub>DD</sub>
9	N/C	N/C
14	+5V, V <sub>DD</sub>	N/C

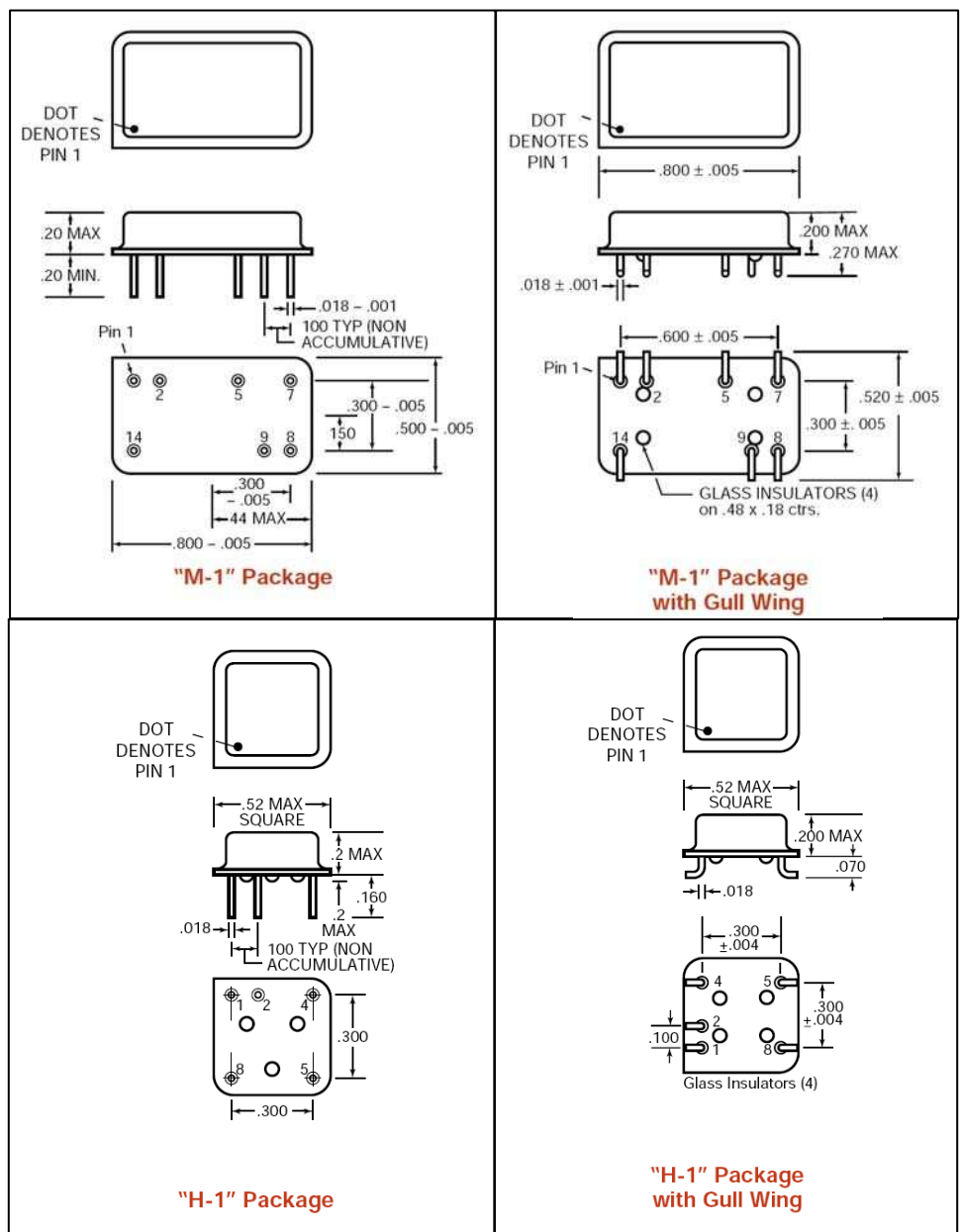

**FREQUENCY VS. CONTROL VOLTAGE FOR TYPICAL DEVICE**

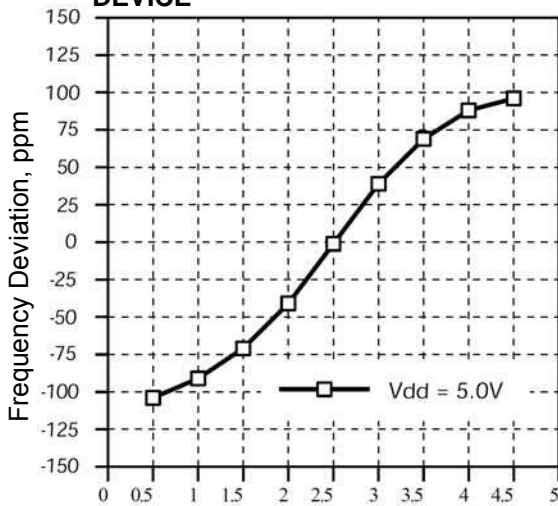

Fig. 2 Deviation from Nominal for M3282-77.76 M

