

Product Specifications

Customer	Standard
Description	2.87" TFT EPD Panel
Model Name	E2287CS051
Date	2016/ 08/ 22
Doc. No.	1P119-00
Revision	02

Customer Approval	
Date	
The above signature represents that the product specifications, testing regulation, and warranty in the specifications are accepted	

	Design Engineering		
	Approval	Check	Design

4F, No.28, Chuangye Rd., Tainan Science Park., Tainan City 74144, Taiwan (R.O.C.)

Tel: + 886-6-279-5399

Fax: + 886-6-505-5300

Copyright

Pervasive Displays Incorporated All rights reserved.

This document is the exclusive property of Pervasive Displays Inc. (PDI) and shall not be reproduced or copied or transformed to any other format without prior permission of PDI. (PDI Confidential)

本資料為龍亭新技股份有限公司專有之財產，非經許可，不得複製、翻印或轉變成其他形式使用。

龍亭新技股份有限公司 Pervasive Displays Inc.

4F, No.28, Chuangye Rd., Tainan Science Park., Tainan City 74144, Taiwan (R.O.C.)

Tel: + 886-6-279-5399

<http://www.pervasivedisplays.com>

Table of Contents

Revision History 6

Glossary of Acronyms 7

1 General Description 8

 1.1 Overview 8

 1.2 Features 8

 1.3 Applications 8

 1.4 General Specifications 9

 1.5 Mechanical Specifications 10

2 Absolute Maximum Ratings 12

 2.1 Absolute Ratings of Environment 12

 2.2 Reliability Test Item 13

 2.3 Product Lifetime 13

 2.4 Product Warranty 13

3 Electrical Characteristics 14

 3.1 Absolute Maximum Ratings of Panel 14

 3.2 Recommended Operation Conditions of Panel 14

4 Application Circuit Block Diagram 16

5 Terminal Pin Assignment & Reference Circuit 17

 5.1 Terminal Pin Assignment 17

 5.2 Reference Circuit 19

 5.3 Glass Breakage Detection 20

6 Optical Characteristics 21

 6.1 Measurement Conditions 21

 6.2 Optical Specifications 21

 6.2.1 Optical 21

 6.2.2 Ghosting 24

7 Packing 25

8 Precautions 27

9 Definition of Labels 29

List of Figures

Figure 1-1 EPD Drawing..... 11

Figure 3-1 Test Pattern of Panel 15

Figure 3-2 Image Update Current Profile..... 15

Figure 3-3 Current Measurement 15

Figure 4-1 Application Circuit Block Diagram 16

Figure 5-1 EPD Reference Circuit 19

Figure 6-1 Optical measurement..... 22

Figure 6-2 Definition of Viewing Angle to Measure Contrast Ratio..... 23

Figure 7-1 Packing Diagram 25

Figure 9-1 Model Label 29

Figure 9-2 Definition of Model Label 29

Figure 9-3 Carton Label 30

Figure 9-4 Pallet Label..... 30

List of Tables

Table 1-1	General Specification	9
Table 1-2	Mechanical Specification	10
Table 1-3	FPC Specification	10
Table 2-1	Absolute Ratings of Environment	12
Table 2-2	Reliability Test Items	13
Table 3-1	Absolute Maximum Ratings of Panel	14
Table 3-2	DC Characteristics of Panel.....	14
Table 5-1	Terminal Pin Assignment	17
Table 6-1	Optical Measurement Conditions	21
Table 6-2	Optical Measurement with D65 Light Source.....	21
Table 6-3	Measurement of Ghosting	24

Revision History

Version	Date	Page (New)	Section	Description
Ver.01	2016/07/05	All	All	Product specification first issued.
Ver.02	2016/08/22	12	2.1	Table 2-1, add humidity ratings.
		13	2.3	Add 2.3 Product Lifetime.
		13	2.4	Add 2.4 Product Warranty.
		21	6.2.1	Table 6-2, add White state optical data.
		24	6.2.2	Modify ghosting measurement.
		27	8	Add precaution (16).

Glossary of Acronyms

EPD	Electrophoretic Display (e-Paper Display)
EPD Panel	EPD
EPD Module	EPD with TCon board
TCon	Timing Controller
TFT	Thin Film Transistor
MCU	Microcontroller Unit
FPC	Flexible Printed Circuit
FPL	Front Plane Laminate
SPI	Serial Peripheral Interface
COG	Chip on Glass
IIS	Incoming Inspection Standard
ISTA	International Safe Transit Association
PDI	Pervasive Displays Incorporated

1 General Description

1.1 Overview

This is a 2.87" a-Si, active matrix TFT, Electronic Paper Display (EPD) panel. The panel has such high resolution (112 dpi) that it is able to easily display fine patterns. Due to its bi-stable nature, the EPD panel requires very little power to update and needs no power to maintain an image.

1.2 Features

- a-Si TFT active matrix Electronic Paper Display(EPD)
- Resolution: 296 x 128
- Ultra low power consumption
- Super Wide Viewing Angle - near 180°
- Extra thin & light
- SPI interface
- RoHS compliant

1.3 Applications

- Electronic shelf label (ESL)
- Reusable container
- Badge

1.4 General Specifications

Table 1-1 General Specification

Item	Specification	Unit	Note
Outline Dimension	79.0(H) x 36.7(V) x 1.0(T)	mm	(1)
Active Area	66.90(H) x 29.06(V)	mm	
Driver Element	a-Si TFT active matrix	-	
FPL	Aurora Mb	-	
Pixel Number	296 x 128	pixel	
Pixel Pitch	0.23 x 0.23 (112dpi)	mm	
Pixel Arrangement	Vertical stripe	-	
Display Colors	Black/White	-	
Surface Treatment	Anti-Glare	-	

Note (1): Not including FPC and Masking Film..

1.5 Mechanical Specifications

Table 1-2 Mechanical Specification

Item		Min.	Typ.	Max.	Unit	Note
Glass Size	Horizontal(H)	78.7	79.0	79.3	mm	
	Vertical(V)	36.4	36.7	37.0	mm	
	Thickness(T)	0.9	1.0	1.1	mm	(1)
Weight		-	5.4	6.5	g	

Note (1): Not including the Masking Film.

Table 1-3 FPC Specification

Item	Number of Pins	Pitch (mm)	Connector	Note
Golden Finger	26	0.5	HRS FH34SRJ 34S or STARCONN 6700S34 or Compatible	(1)

Note (1): HRS FH34SRJ 34S and STARCONN 6700S34 are 34-pins connectors. The middle 26 pins are used to connect FPC pads of EPD. The other 8 pins are used as dummy pins. Please refer PDI demo kit for detailed connection.

Figure 1-1 EPD Drawing

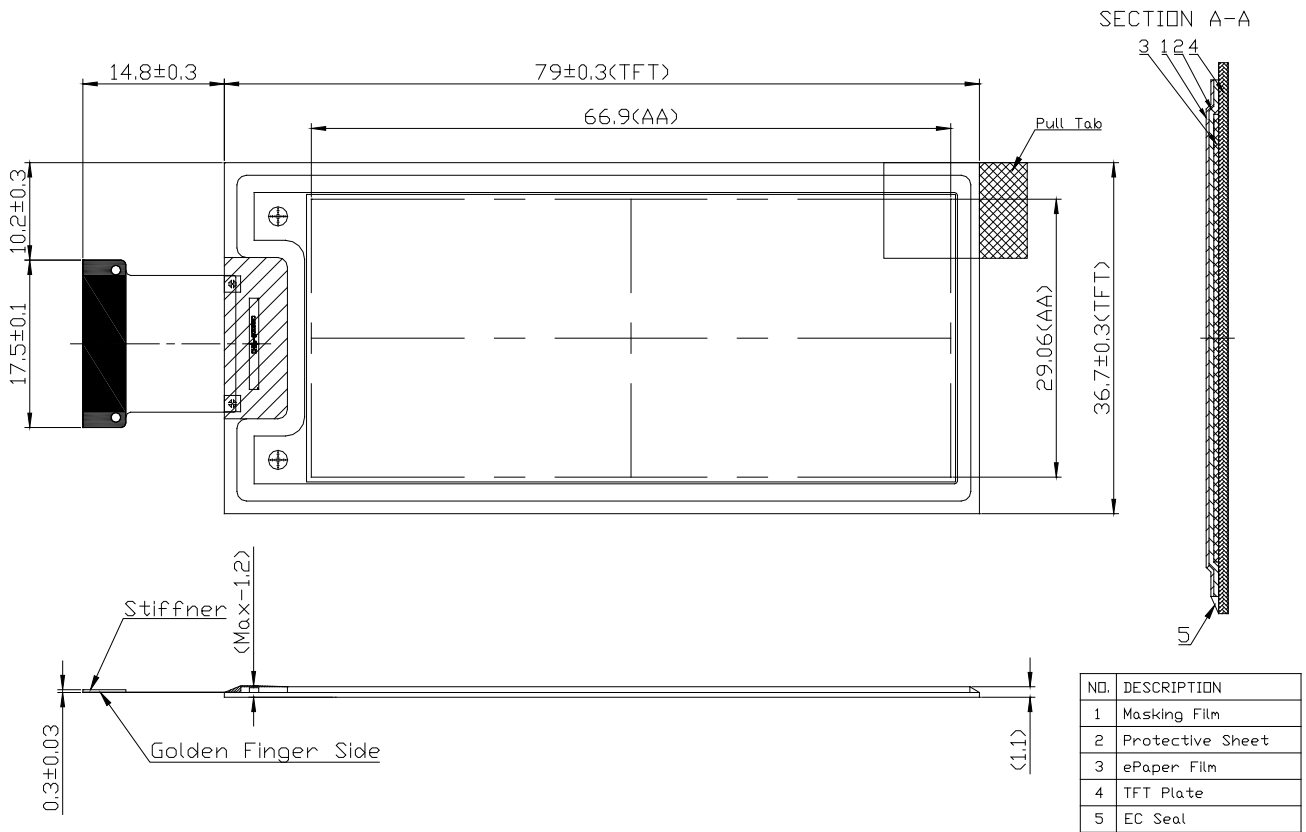

General tolerance: ±0.3mm

2 Absolute Maximum Ratings

2.1 Absolute Ratings of Environment

Table 2-1 Absolute Ratings of Environment

Item	Symbol	Value		Unit	Note
		Min.	Max.		
Storage Temperature	T _{ST}	-20	+ 60	°C	(1),(3)
Storage Humidity	H _{ST}	30	90	% RH	(1),(3)
Operating Ambient Temperature	T _{OP}	0	+ 50	°C	(1),(2),(4)
Operating Ambient Humidity	H _{OP}	30	90	% RH	(1),(2),(4)
Optimal Storage Temperature	T _{STo}	-10	35	°C	(1),(3)
Optimal Storage Humidity	H _{STo}	40	60	% RH	(1),(3)

Note (1):

- (a) 90 %RH Max. ($T_a \leq 40 \text{ }^\circ\text{C}$), where T_a is ambient temperature.
- (b) Wet-bulb temperature should be 39 °C Max. ($T_a > 40 \text{ }^\circ\text{C}$).
- (c) No condensation and no frost in absolute ratings of Environment.

Note (2): The temperature of panel display surface area should be 0 °C Min. and 50 °C Max. Refresh time depends on operation temperature.

Note (3): E Ink Material is Moisture and UV sensitive. The absolute rating operating environments describes the boundary conditions for updating the display while the absolute rating storage environment describe the boundary conditions for a display not updating. While displays are rated to perform according to specification for the warranty period at the absolute specified operating environment, the better the storage condition, the better the E Ink displays will perform. Similar to other moisture and UV sensitive components, we recommend that our displays be stored in temperature and humidity control environments, and whenever possible, under above defined Optimal Storage Condition, away from sunlight, to optimize their performance.

Note (4): The performance of EPD may be degraded under sunlight. Please customer consults PDI if customer wants to use EPD under sunlight.

2.2 Reliability Test Item

Table 2-2 Reliability Test Items

Item	Test Condition	Remark
High Temperature Operation	50 °C / 30% RH for 240h	(1) (2)
Low Temperature Operation	0 °C for 240h	(1) (2)
High Temperature/Humidity Operation	40 °C / 90 % RH for 240h	(1) (2)
High Temperature Storage	60 °C / 30% RH for 240h	(1) (2)(3)
Low Temperature Storage	-20 °C for 240h	(1) (2) (3)
High Temperature/Humidity Storage	60 °C / 80 % RH for 240h	(1) (2) (3)
Thermal Cycles (Non-operation)	1 Cycle: -20°C/30min → 60°C/30min, for 100 Cycles	(1) (2) (3)
Package Drop Test	Drop from 97cm. (ISTA) 1 corner, 3 edges, 6 sides. One drop for each.	(1) (2) (3)
Package Random Vibration Test	1.15Grms, 1Hz ~ 200Hz. (ISTA)	(1) (2) (3)

Note (1): No condensation and no frost during test. End of test, function, mechanical, and optical shall be satisfied with product specification and IIS.

Note (2): The test result and judgment are based on PDI's 1bit driving waveform, driving fixture and driving system.

Note (3): Stay white pattern for storage and non-operation test.

2.3 Product Lifetime

The EPD Module is designed for a 5-year life-time with 25 °C/50%RH operation assumption. Reliability estimation testing with accelerated life-time theory would be demonstrated to provide confidence of EPD lifetime.

2.4 Product Warranty

Warranty conditions have to be negotiated between PDI and individual customers. PDI provides 13months warranty for all products which are purchased from PDI.

3 Electrical Characteristics

3.1 Absolute Maximum Ratings of Panel

Table 3-1 Absolute Maximum Ratings of Panel

Parameter	Symbol	Value		Unit	Note
		Min	Max		
Logic supply voltage	V_{CC}, V_{DD}, V_{DDIO}	-0.3	6.0	V	
Ground	GND	-		-	Connect to Ground

3.2 Recommended Operation Conditions of Panel

Table 3-2 DC Characteristics of Panel

Parameter	Symbol	Value			Unit	Note	
		Min	Typ	Max			
Operation voltage	V_{CC}, V_{DD}, V_{DDIO}	2.3	3.0	3.6	V		
Input Voltage	High	V_{IH}	$0.7V_{DDIO}$	-	V_{DDIO}	V	
	Low	V_{IL}	0	-	$0.3V_{DDIO}$	V	
Output Voltage	High	V_{OH}	$V_{DDIO}-0.4$	-	-	V	$V_{DDIO}=V_{DD}$ $I_{OH}=400\mu A$
	Low	V_{OL}	-	-	0.4	V	$V_{DDIO}=V_{DD}$ $I_{OL}=-400\mu A,$
Input Current	$I_{DD+} I_{CC}$	-	8.2	-	mA	(1),(2),(3)	

$T_a = 25 \pm 2 \text{ }^\circ\text{C}$

Note (1):

Figure 3-1 Test Pattern of Panel



These currents are tested with PDI test jig.

Note (2):

$$V_{DD} = V_{CC} = 3.0V$$

Figure 3-2 Image Update Current Profile

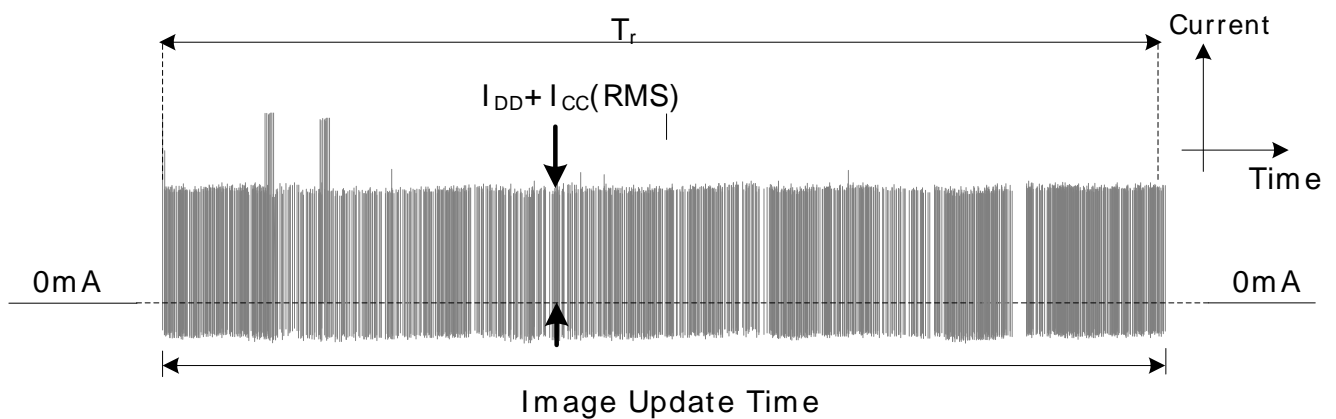

Note (3): I_{DD} : The current of $V_{DD} + V_{DDIO}$.

I_{CC} : The current of V_{CC} (EPD Boost Circuit).

Figure 3-3 Current Measurement

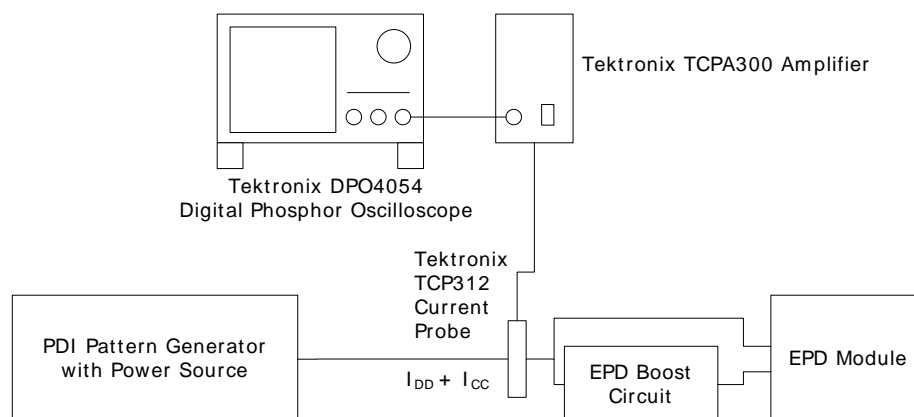

* Set oscilloscope filter to 250MHz and record length to 1M points.

4 Application Circuit Block Diagram

Figure 4-1 Application Circuit Block Diagram

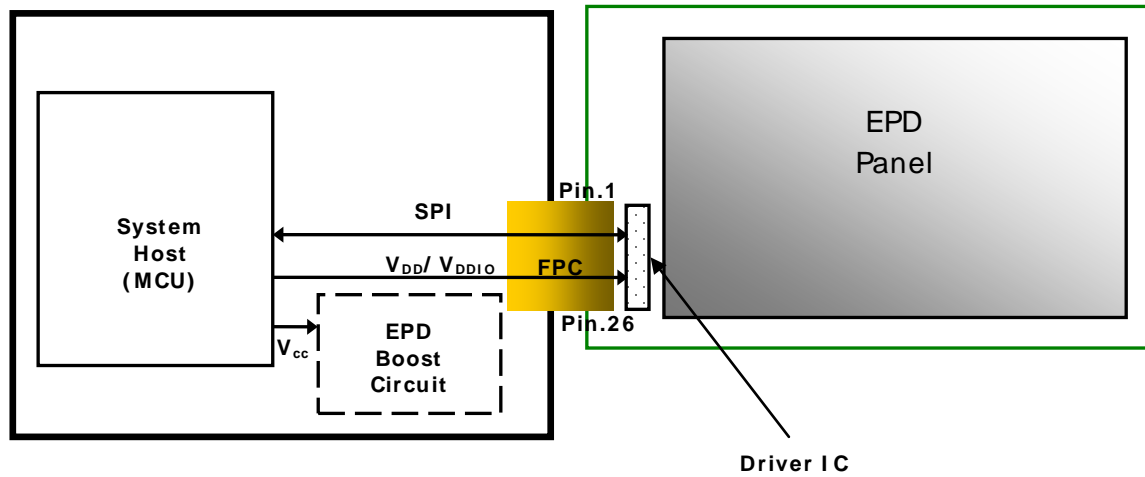

5 Terminal Pin Assignment & Reference Circuit

5.1 Terminal Pin Assignment

Table 5-1 Terminal Pin Assignment

No.	Signal	Type	Connected to	Function
1	GUARD1	O	System I/O	Glass Breakage Detection H: Normal L: Broken
2	NC	-	-	-
3	GDR	O	Power MOSFET Driver Control	This pin is the N-Channel MOSFET Gate Drive Control.
4	RESE	I	Booster Control Input	This pin is the Current Sense Input for the Control Loop.
5	NC	-	-	-
6	VDHR	-	-	Not connected
7	NC	-	-	Not connected
8	NC	-	-	Not connected
9	BS	I	Ground	This pin is setting panel interface.
10	BUSY_N	O	Device Busy Signal	This pin is Busy state output pin. L: Driver is busy, data/ command is transforming. H: Host side can send command/data to driver
11	RST_N	I	System Reset	This pin is reset signal input. Active Low.
12	DC	I	Serial Bus	This pin is Data/Command control. L: command H: data
13	CSB	I	Serial Bus	This pin is the chip select.
14	SCL	I	Serial Bus	Serial communication clock input

No.	Signal	Type	Connected to	Function
15	SDA	I/O	Serial Bus	Serial communication data input
16	VDDIO	P	Power Supply	Power supply for interface logic pins & I/O.
17	VDD	P	Power Supply	Power supply for digital.
18	GND	P	Ground	-
19	VDDD	P	Capacitor	This pin is the internal LDO(1.8V)
20	NC	-	-	-
21	VDH	C	Capacitor	This pin is the positive source driving voltage. A stabilizing capacitor should be connected between VDH and GND.
22	VGH	C	Capacitor	This pin is the positive gate driving voltage. A stabilizing capacitor should be connected between VGH and GND.
23	VDL	C	Capacitor	This pin is the negative source driving voltage. A stabilizing capacitor should be connected between VDL and GND.
24	VGL	C	Capacitor	This pin is the negative gate driving voltage. A stabilizing capacitor should be connected between VGL and GND.
25	VCOM	C	Capacitor	This pin is the VCOM driving voltage A stabilizing capacitor should be connected between VCOM and GND.
26	GUARD2	O	System I/O	Glass Breakage Detection H: Normal L: Broken

Note:

Type: I: Input O: Output
 C: Capacitor P: Power

5.2 Reference Circuit

Figure 5-1 EPD Reference Circuit

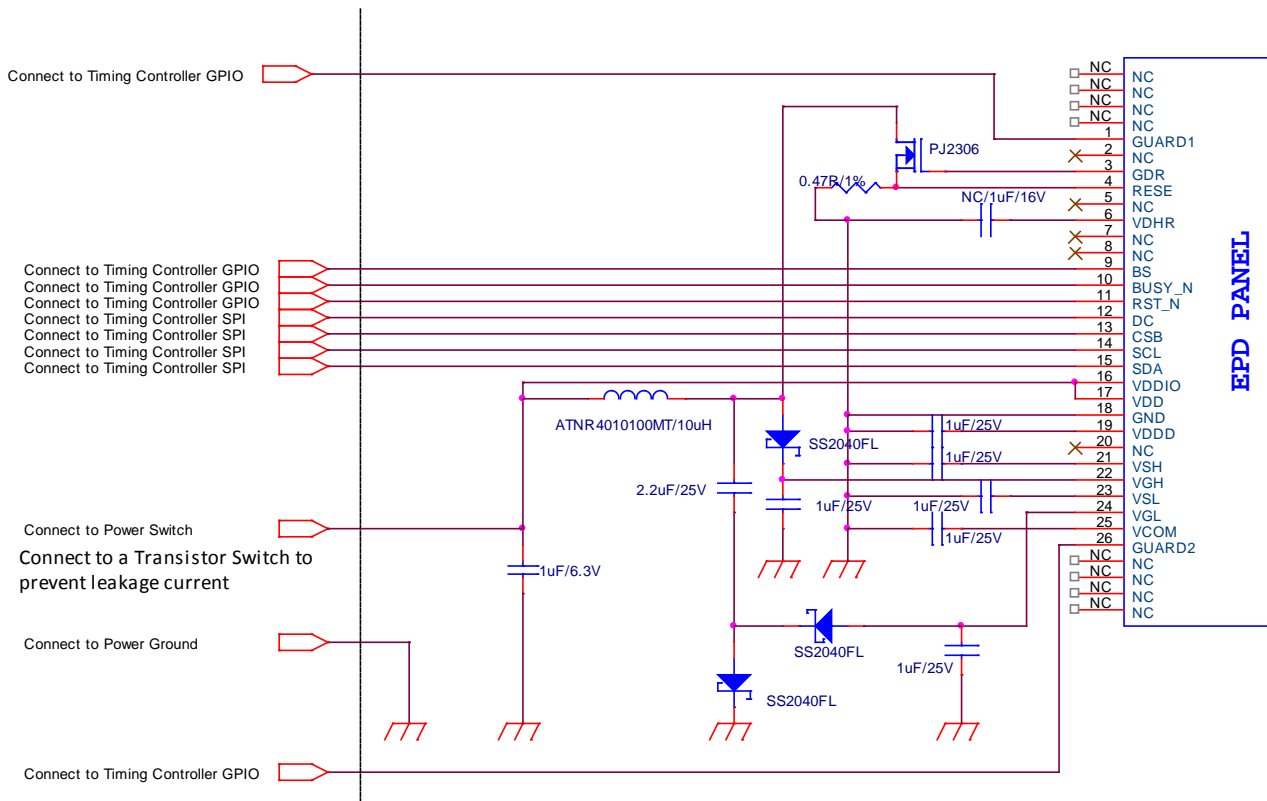

Note (1): HRS FH34SRJ 34S and STARCONN 6700S34 are 34-pins connectors. The middle 26 pins are used to connect FPC pads of EPD. The other 8 pins are used as dummy pins.

Type	Part	Vendor
Inductor	10uH ATNR4010100MT + -20% 0.8A H= 0.9mm	ARLITECH
Transistor	PJ2306 SOT-23 N-Channel 30V/3.2A	PANJIT
Diode	SS2040FL SOD-123FL	PANJIT

Note:

- (1) PJ2306 is a N-Channel Power MOSFET. The specification of selection criteria are $R_{DS} < 100$ mohm (the lower the better), $V_{DSS} = 30V$, $V_{GS-th} < 2.5V @ 250uA$.
- (2) SS2040FL is a Schottky diode needs the V_f as lower as possible, 0.2 to 0.4V and the repetitive peak reverse voltage $> 25V$.

5.3 Glass Breakage Detection

Breakage detection is a new feature that can let user know whether the glass substrate is broken. Before update, the system controller can check the signal on Guard Ring (Guard1 and Guard2). If this signal is not V_{DDIO} , the glass is possibly broken. In this case, the EPD may be not able to display image correctly. This feature is very critical for the bi-stable displays.

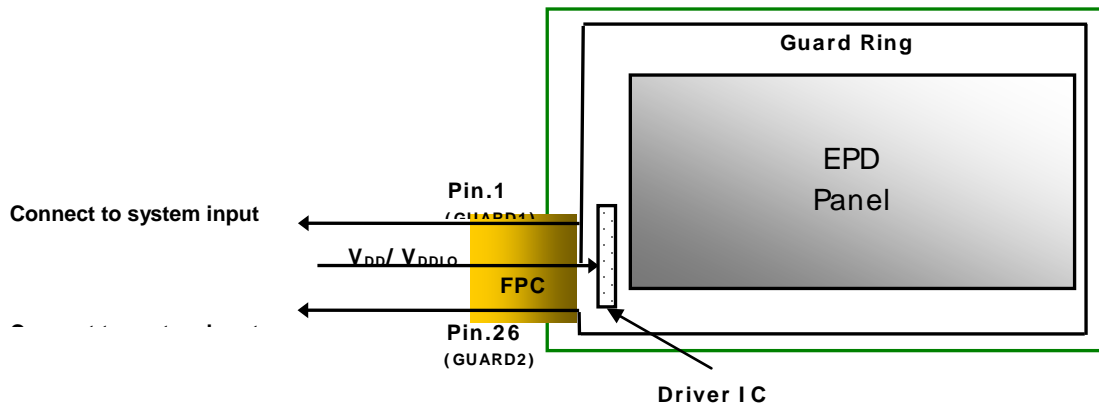

- Note (1): If there is not enough system controller GPIO. Using pin 26 of FPC can have larger coverage to detect breakage.
- Note (2): The GPIOs must add a resistor to ground when the GPIO don't have the internal resistor to ground.

6 Optical Characteristics

6.1 Measurement Conditions

Table 6-1 Optical Measurement Conditions

Item	Symbol	Value	Unit
Ambient Temperature	Ta	25±2	°C
Ambient Humidity	Ha	50±10	% RH
Supply Voltage	V _{CC} , V _{DD} , V _{DDIO} , V _{DDA}	3.0	V

Note (1): Image is updated with above condition.

6.2 Optical Specifications

6.2.1 Optical

Table 6-2 Optical Measurement with D65 Light Source

Item	Symbol	Rating			Unit	Note
		Min.	Typ.	Max.		
Contrast ratio	CR	-	11:1	-	-	$\theta_x=\theta_y=0$ (1),(2),(4),(5)
Refresh time	Tr	-	2.5	-	sec	(3),(5)
White state	L*	-	71	-	-	$\theta_x=\theta_y=0$ (1),(2),(5)
	a*		-2.8			
	b*	-	0.1	-		
Reflectance	R%	-	43	-	%	(1),(2),(5)

Note (1): Panel is driven by PDI waveform without masking film and optical measurement by CM-700D with D65 light source and SCE mode.

Figure 6-1 Optical measurement

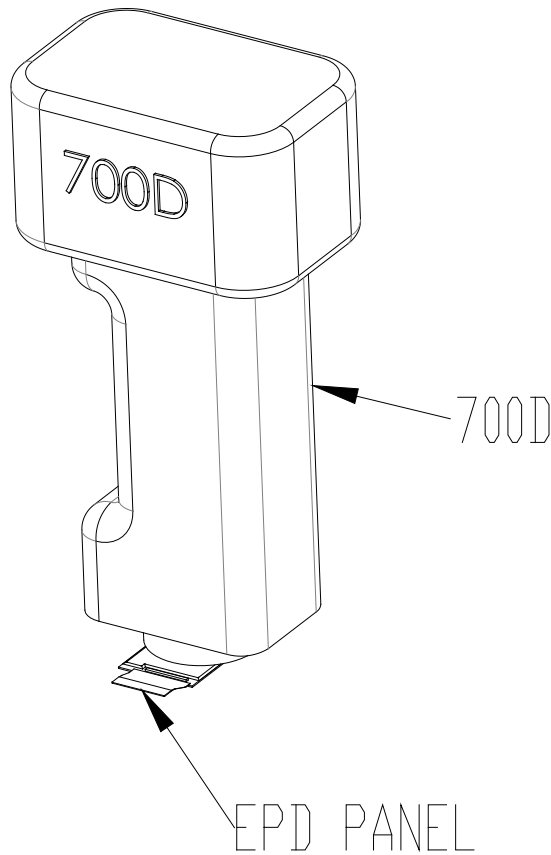

(face up and remove protection film)

SCE mode

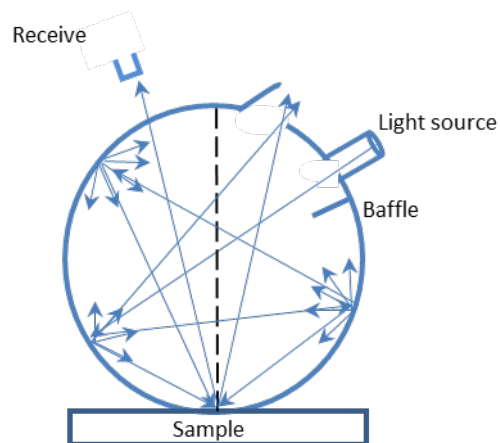

Note (2): Definition of Viewing Angle (θ_x , θ_y):

Figure 6-2 Definition of Viewing Angle to Measure Contrast Ratio

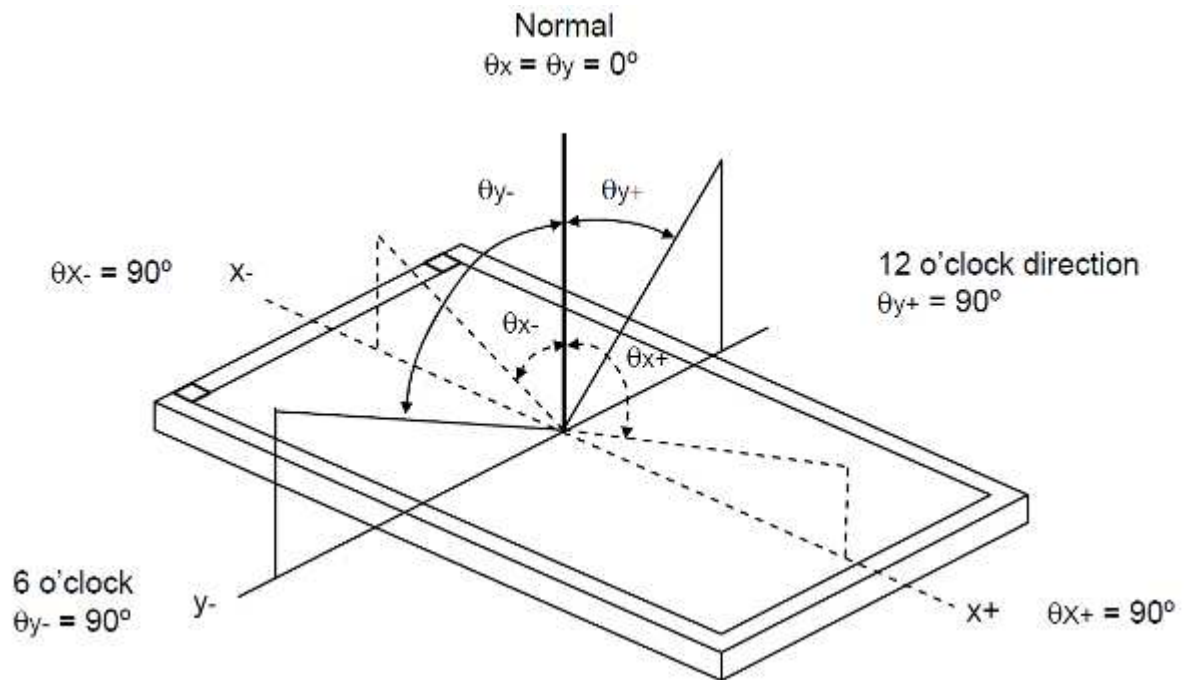

Note (3): Refresh time is the time that e-paper particles move not including the power on and off time. The refresh time is measured at 25°C. The refresh time and contrast ratio varies due to different films, display performance requirements, and ambient temperatures.

Note (4): T_r is the refresh time. For an image with White / Black, the total update time is (T_r).

Note (5): Contrast ratio (C.R.): The Contrast ratio is calculated by the following expression. $C.R. = (R\% \text{ White}) / (R\% \text{ Black})$.

Note (6): Optical data is measured at 60 seconds after refresh with PDI's global update procedure.

6.2.2 Ghosting

Below are two test methods to verify if ghosting is within an acceptable range. Test 1 and Test 2 use measured data to calculate color different, ΔE_{00} (CIEDE 2000).

The condition of measurement is to follow “ Table 6-1 Optical Measurement Conditions”.

- Test 1: White to Black Ghosting

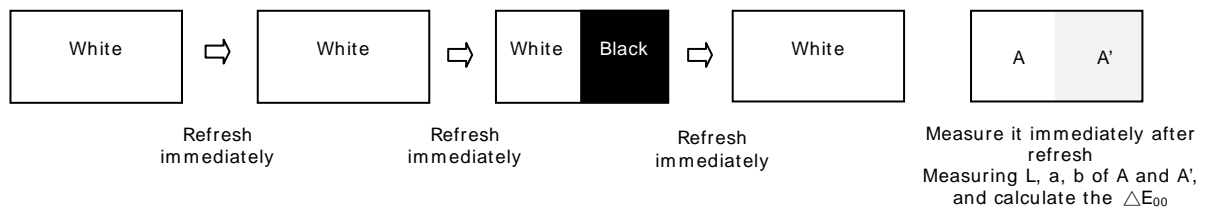

- Test 2: Black to White Ghosting

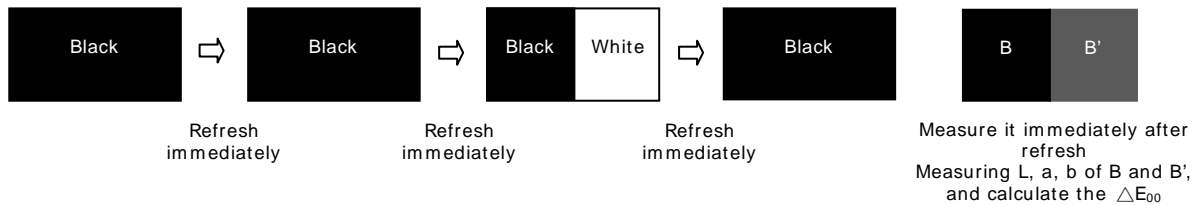

Table 6-3 Measurement of Ghosting

Item	Rating		
	Min.	Typ.	Max.
Test 1 ΔE_{00}	-	-	2
Test 2 ΔE_{00}	-	-	2

Note: Panel is driven by PDI waveform without masking film and optical measurement by CM-700D with D65 light source and SCE mode.

7 Packing

Figure 7-1 Packing Diagram

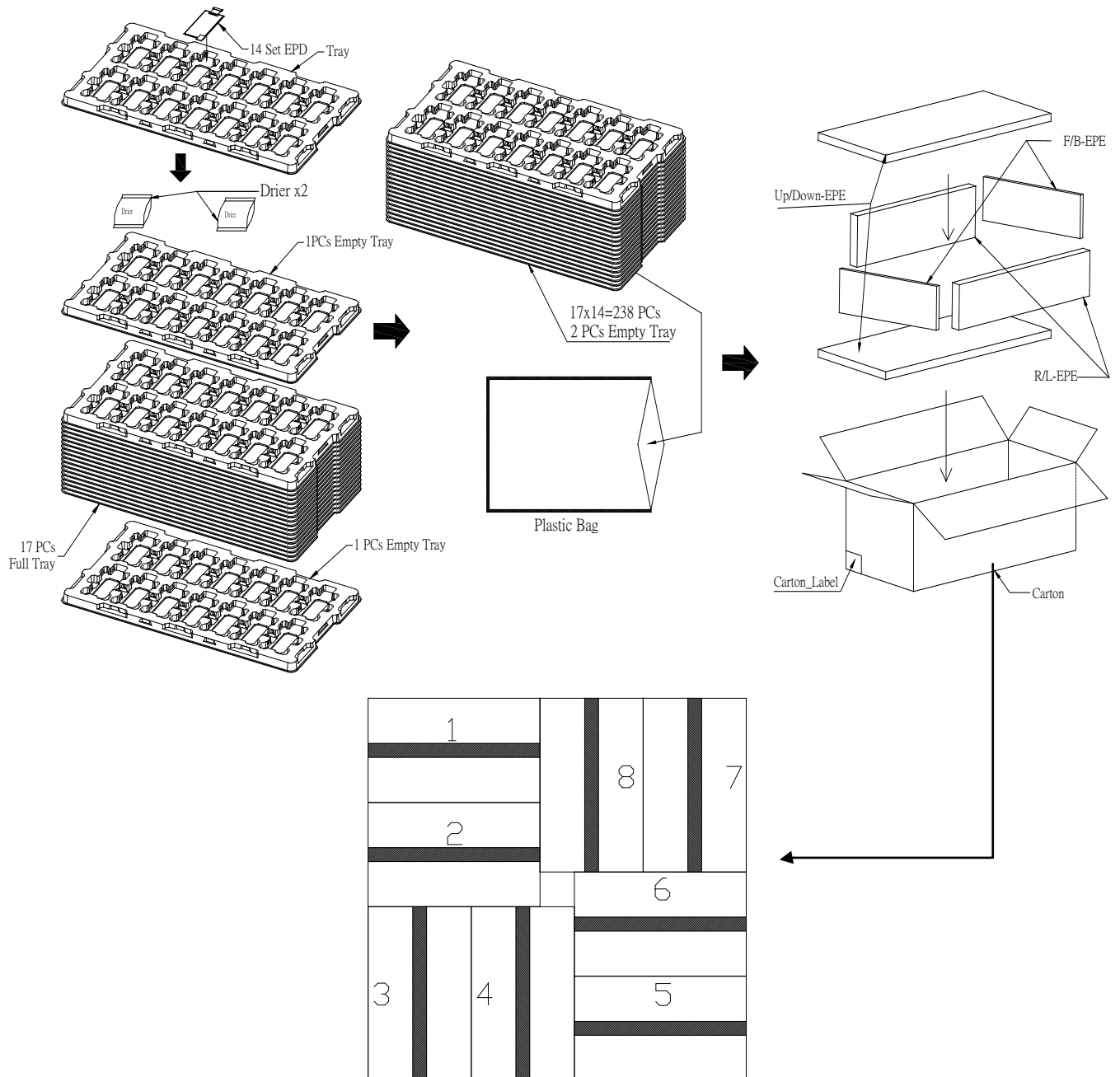

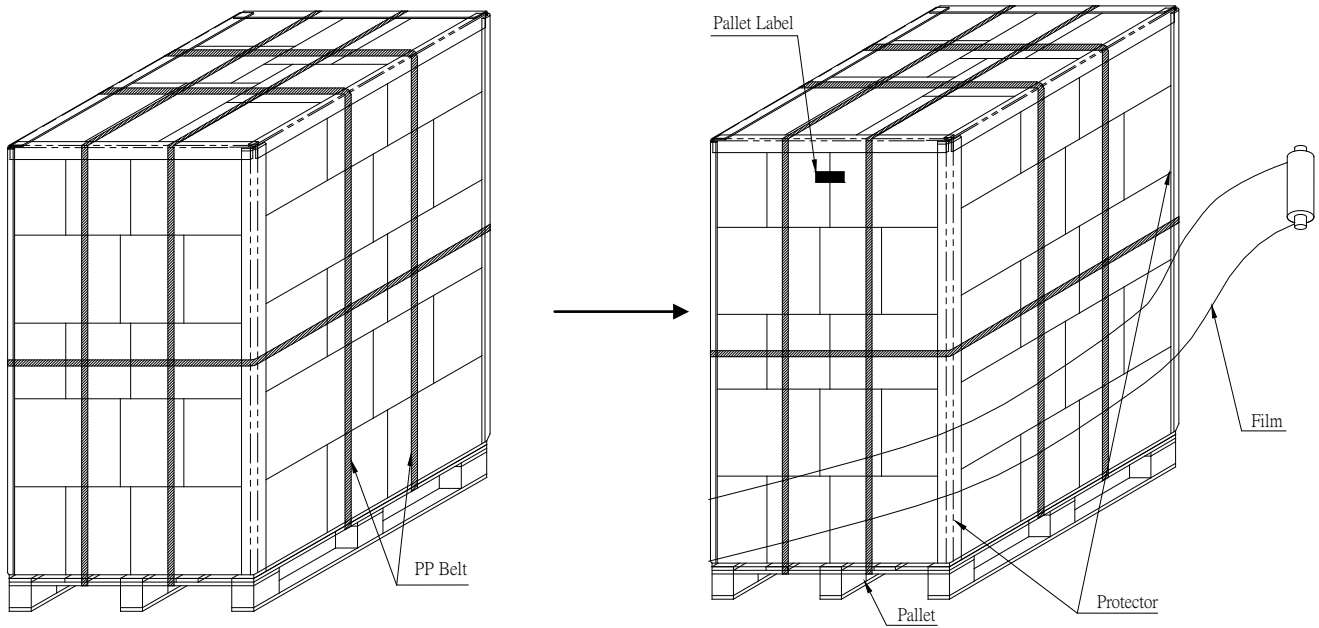

238(pcs)x40(BOX)=9,520pcs

	2.87" EPD BOX
N.W. :	1.29 Kg
G.W. :	4.76 Kg

Sea / Land / Air Transportation

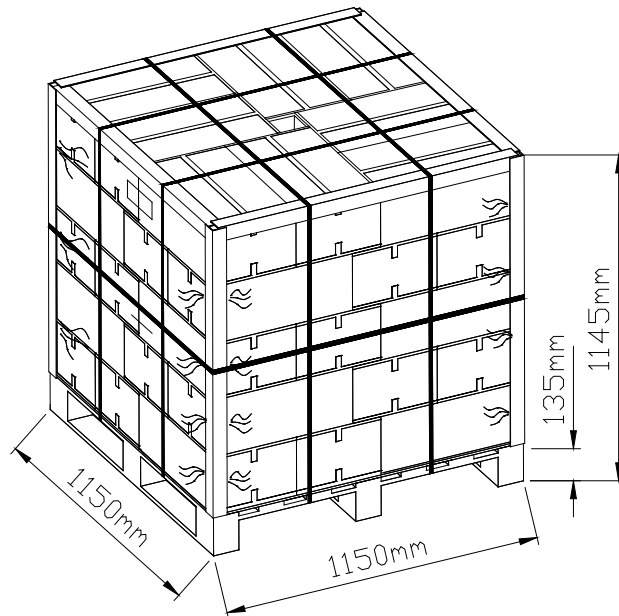

8 Precautions

- (1) The EPD Panel / Module is manufactured from fragile materials such as glass and plastic, and may be broken or cracked if dropped. Please handle with care. Do not apply force such as bending or twisting to the EPD panel during assembly. Please put on gloves to handle EPD to avoid slash.
- (2) It is recommended to assemble or install EPD panels in a clean working area. Dust and oil may cause electrical shorts or degrade / scratch / dent the protection sheet film.
- (3) Do not apply pressure to the EPD panel in order to prevent damaging it.
- (4) Do not connect or disconnect the interface connector while the EPD panel is in operation.
- (5) Please support the bezel with your finger while connecting the interface cable such as the FPC.
- (6) Do not stack the EPD panels / Modules.
- (7) Do not press the FPC on the glass edge or Pull FPC up / down to 90°.
- (8) Do not touch the FPC lead connector.
- (9) Do not touch IC bonding area. It may scratch TFT lead or damage IC function.
- (10) Wear a Wrist Strap (Grounding connect) when handling and during assembly. Semiconductor devices are included in the EPD Panel / Module and they should be handled with care to prevent any electrostatic discharge (ESD). (An Ion Fan may be needed in assembly operation to reduce ESD risk.)
- (11) Keep the EPD Panel / Module in the specified environment and original packing boxes when storage in order to avoid scratching and keep original performance.
- (12) Do not disassemble or reassemble the EPD Panel / Module.
- (13) Use a soft dry cloth without chemicals for cleaning. Please don't press hard for cleaning because the surface of the protection sheet film is very soft and without hard coating. This behavior would make dent or scratch on protection sheet.
- (14) Please be mindful of moisture to avoid its penetration into the EPD panel, which may cause damage during operation.
- (15) It's low temperature operation product. Please be mindful the temperature different to make frost or dew on the surface of EPD panel. Moisture may penetrate into the EPD panel because of frost or dew on surface of EPD panel, and makes EPD panel damage.
- (16) If the EPD Panel / Module is not refreshed every 24 hours, a phenomena known as "Ghosting" or "Image Sticking" may occur. It is recommended that customer refreshed the ESL / EPD Tag every 24 hours in use case. It is recommended that customer ships or stores the ESL / EPD Tag with a completely white image to avoid this issue.
- (17) High temperature, high humidity, sunlight or fluorescent light may degrade the EPD panel's performance. Please do not expose the unprotected EPD panel to high temperature, high humidity, sunlight, or fluorescent for long periods of time.
- (18) The label ink used for marking the Panel ID number is erased easily by solvent. Please avoid using solvent to clean the EPD panel. It would be concerned for RMA.
- (19) The EPD Panel / Module is vacuum packed with white image for shipment and

storage.

- (20) Before approved by PDI and customer, products and product specifications may be subject to change without notice. Confirm that you have received the latest product standards or specifications before final design, purchase or use.
- (21) PDI makes every attempt to ensure that its products are of high quality and reliability. However, contact PDI sales office before using the product in an application that demands especially high quality and reliability or where its failure or malfunction may directly threaten human life or cause risk of bodily injury, such as aerospace, aeronautics, nuclear power, combustion control, transportation, traffic, safety equipment or medical equipment for life support.
- (22) Design your application so that the product is used within the ranges guaranteed by PDI particularly for maximum rating, operating supply voltage range, heat radiation characteristics, installation conditions and other characteristics. PDI bears no responsibility for failure or damage when used beyond the guaranteed ranges. Even within the guaranteed ranges, consider normally foreseeable failure rates or failure modes in semiconductor devices and employ systemic measures such as fail safes, so that the equipment incorporating PDI product does not cause bodily injury, fire or other consequential damage due to operation of the PDI product.
- (23) This product is not designed to be radiation resistant.
- (24) Please keep $R \geq 1.0\text{mm}$ when bend for assembly.

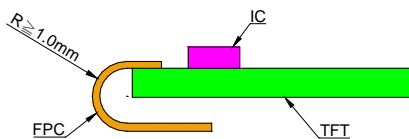

9 Definition of Labels

Figure 9-1 Model Label

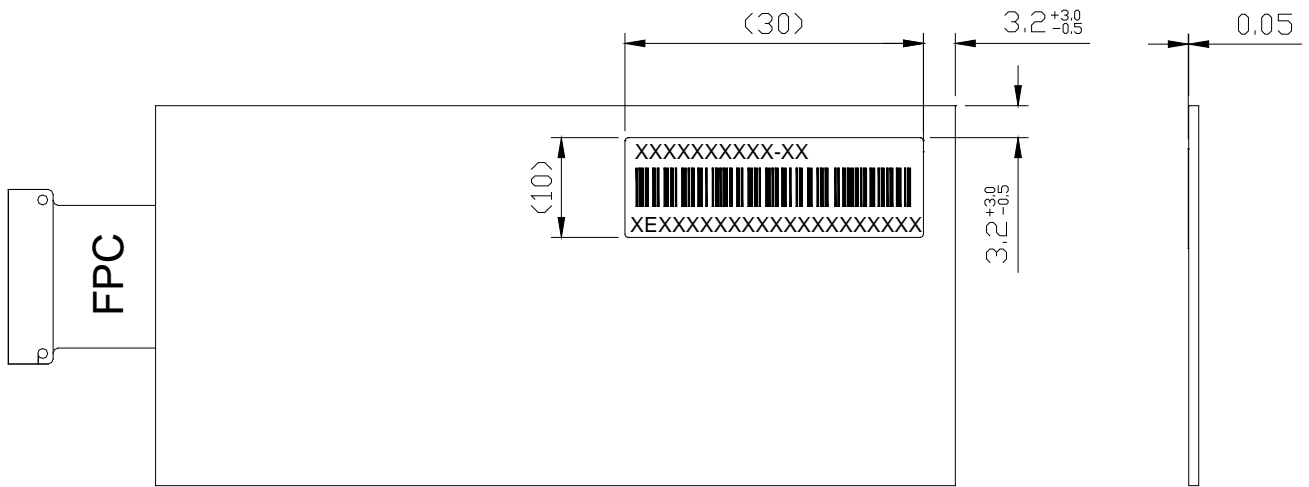

Figure 9-2 Definition of Model Label

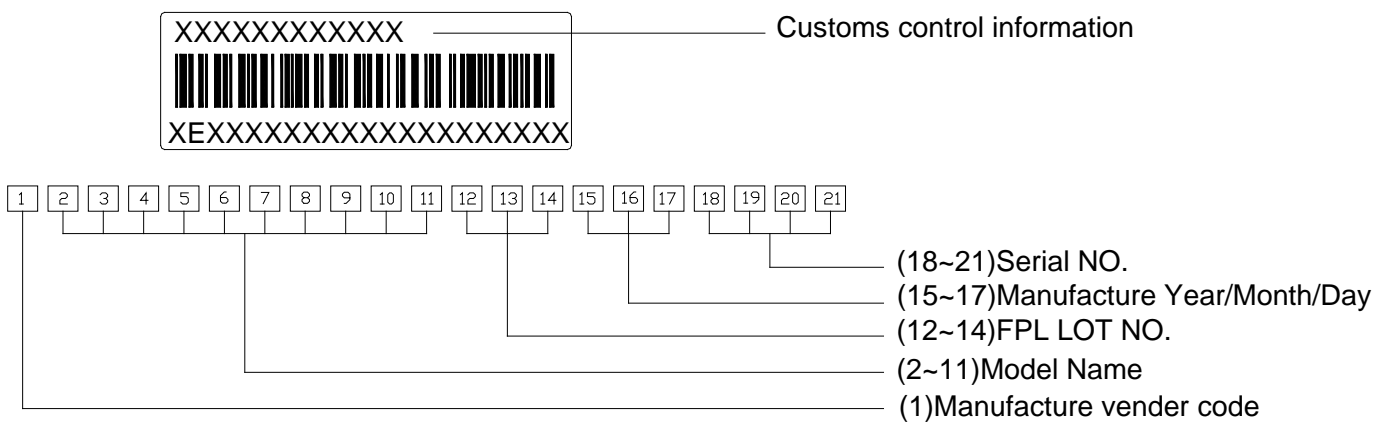
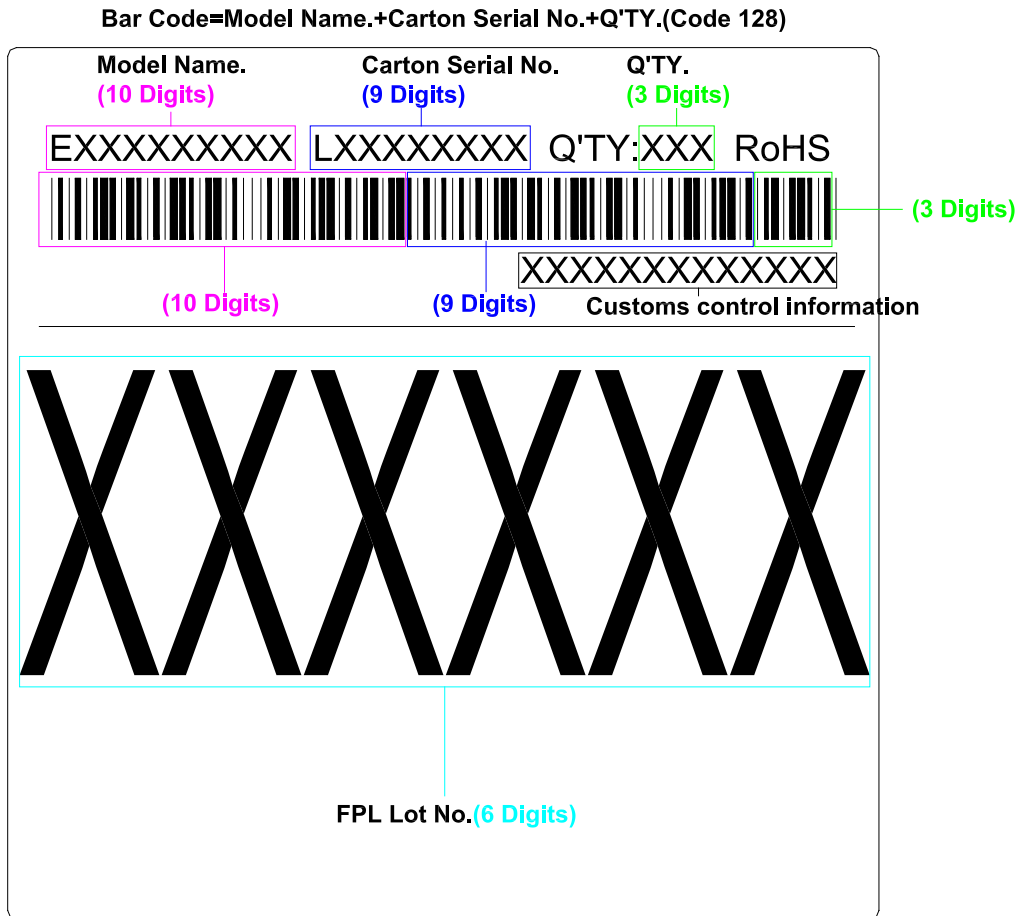
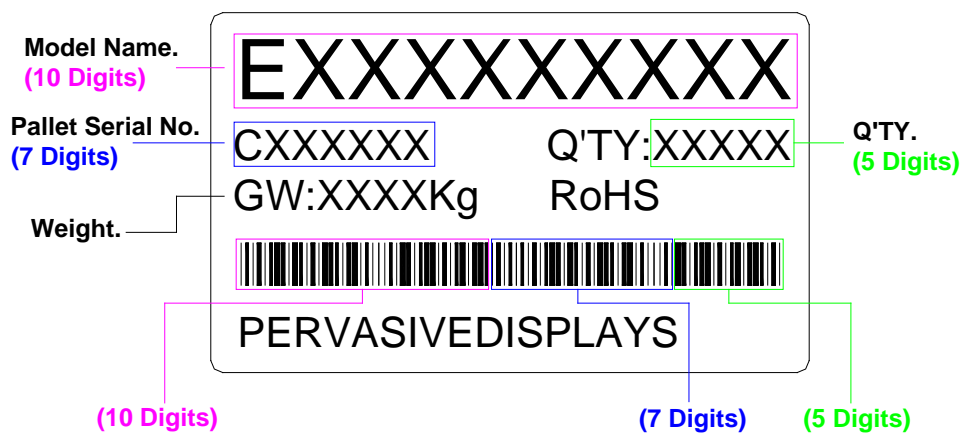

Figure 9-3 Carton Label



Carton Label

Figure 9-4 Pallet Label



Bar Code=Model Name.+Pallet Serial No.+Q'TY.(22 Digits)

Pallet Label