

VFVX110

VCXO Low Noise to 1.0GHz

9x14mm SMD, PECL/LVPECL



Features

- 200MHz to 1.0 GHz Frequency Range
- Ultra Low Jitter and Phase Noise
- Absolute Pull Range of ± 50 ppm
- $K_{VCO} = 85$ ppm/V

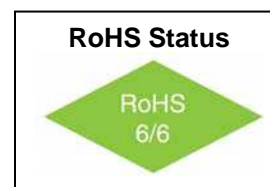

Applications

- Optical Networking, SONET / SDH
- 10 Gigabit Ethernet
- Broadband Access

Electrical Specifications

Parameter	Symbol	Condition	Min	Typ	Max	Unit	Note	
Frequency Range	F		200		1,000	MHz		
Frequency Stability	$\Delta F/F$	Vs. Operating Temperature B: 0°C to +70°C C: -10°C to +60°C G: -40°C to +85°C		± 10 ± 12 ± 18	± 20 ± 25 ± 30	ppm		
		Vs. Supply Voltage Vs. Aging / Year		± 3 ± 1		ppm/V ppm	First Year	
Operating Temperature Range	T		0° -10° -40°		+70° +60° +85°	°C	Order Code B Order Code C Order Code G	
Output		Signal	PECL / LVPECL					
Supply Voltage	Vcc		4.75 3.15	5.00 3.30	5.25 3.45	V	Order Code D Order Code E	
Voltage Control	Vc		0 0		5.0 3.3	V	Vcc = 5.0V Vcc = 3.3V	
Input Impedance			>50K Ω					
K_{VCO}				85		ppm/V		
APR			± 50			ppm	See Note 1	
Deviation slope		<i>Monotonic positive</i>						
Linearity			-10		+10	%		
Modulation BW			>10KHz				3dB BW	
Supply Current	Icc	50 Ohm Load			75	mA		

Note 1: APR is available up to ± 100 ppm minimum – consult factory for specific requirements.



VFVX110
VCXO Low Noise to 1.0GHz
9x14mm SMD, PECL/LVPECL



Electrical Specifications

Parameter	Symbol	Condition	Min	Typ	Max	Unit	Note
Load	50 Ohm to Vcc-2V or Thevenin Equivalent Bias Required						
Duty Cycle		@ 50%	45	50	55	%	
Rise / Fall Time	Tr/Tf	20% to 80%			0.6	ns	
Output Logic "1" Level	Voh		Vcc-0.96		Vcc-0.81	V	
Output Logic "0" Level	Vol		Vcc-1.85		Vcc-1.65	V	
Start up time				2	10	ms	
Jitter (RMS)		12KHz to 20MHz		0.2	0.5	ps	
SSB Phase Noise		100Hz 1KHz 10KHz 100KHz		-93 -118 -142 -145		dBc/Hz	@ 622.08MHz
Subharmonics				-50	-40	dBc	
Enable / Disable Function	Input HIGH (>2.5V): DISABLED Input LOW (<0.5V) or floating: ACTIVE						
Enable / Disable Time	Te/Td				100	ns	

How to Order

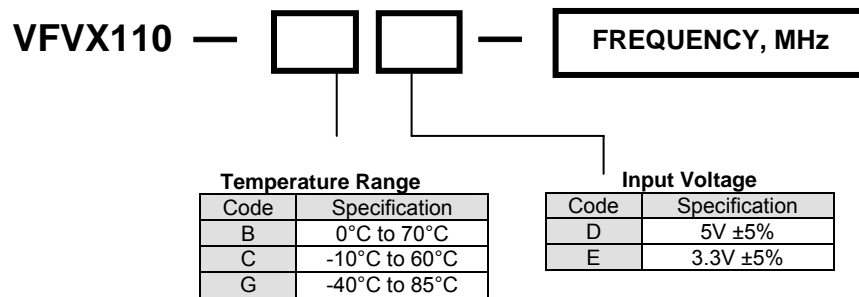

VFVX110

VCXO Low Noise to 1.0GHz

9x14mm SMD, PECL/LVPECL



Absolute Maximum Ratings

Parameter	Symbol	Condition	Min	Typ	Max	Unit	Note
Supply Break Down Voltage	V _{cc}		-0.5		6.0	V	
Storage Temperature	T _s		-55		+85°	°C	
Control Voltage	V _c		-1		7	V	

Environmental and Mechanical

Parameter	Specification
Mechanical Shock	Per MIL-STD-202, Method 213, Condition E
Thermal Shock	Per MIL-STD-883, Method 1011, Condition A
Vibration	Per MIL-STD-883, Method 2007, Condition A
Soldering Conditions	260°C for 10s max
Hermetic Seal	Leak rate less than 5×10^{-8} atm.cc/s of helium (crystal only)

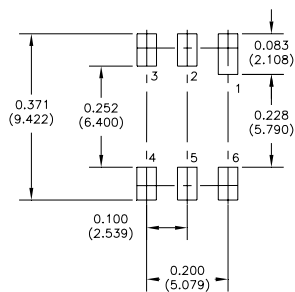
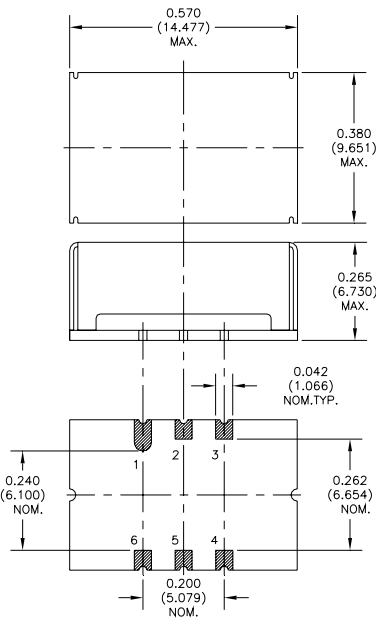
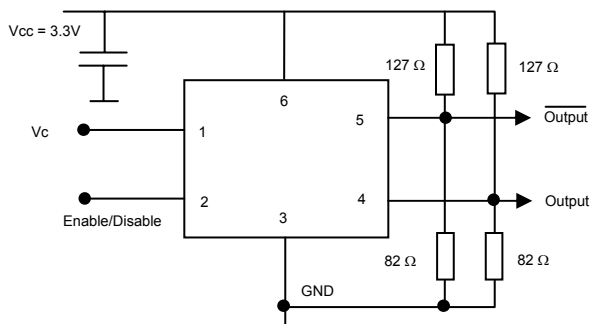

Pin #	Connection
1	V _c
2	Enable
3	Case, GND
4	Output
5	Output
6	V _{cc}

