



# LPC43S70

**32-bit ARM Cortex-M4 + 2 x M0 MCU; 282 kB SRAM; Ethernet; two HS USBs; 80 Msps 12-bit ADC; configurable peripherals, AES engine**

Rev. 1.2 — 15 March 2016

Product data sheet

## 1. General description

---

The LPC43S70 are ARM Cortex-M4 based microcontrollers for embedded applications which include an ARM Cortex-M0 coprocessor and an ARM Cortex-M0 subsystem for managing peripherals, 282 kB of SRAM, advanced configurable peripherals such as the State Configurable Timer (SCTimer/PWM) and the Serial General Purpose I/O (SGPIO) interface, security features with AES engine, two High-speed USB controllers, Ethernet, LCD, an external memory controller, and multiple digital and analog peripherals including a high-speed 12-bit ADC. The LPC43S70 operate at CPU frequencies of up to 204 MHz.

The ARM Cortex-M4 is a 32-bit core that offers system enhancements such as low power consumption, enhanced debug features, and a high level of support block integration. The ARM Cortex-M4 CPU incorporates a 3-stage pipeline, uses a Harvard architecture with separate local instruction and data buses as well as a third bus for peripherals, and includes an internal prefetch unit that supports speculative branching. The ARM Cortex-M4 supports single-cycle digital signal processing and SIMD instructions. A hardware floating-point unit is integrated in the core. The ARM Cortex-M4 with floating-point unit is often referred to as M4F.

The LPC43S70 include an application ARM Cortex-M0 coprocessor and a second ARM Cortex-M0 subsystem for managing the SGPIO and SPI peripherals. The ARM Cortex-M0 core is an energy-efficient and easy-to-use 32-bit core which is code- and tool-compatible with the Cortex-M4 core. Both Cortex-M0 cores offer up to 204 MHz performance with a simple instruction set and reduced code size. The Cortex-M0 does not support hardware multiply.

## 2. Features and benefits

---

- Main Cortex-M4 processor
  - ◆ ARM Cortex-M4 processor, running at frequencies of up to 204 MHz.
  - ◆ Built-in Memory Protection Unit (MPU) supporting eight regions.
  - ◆ Built-in Nested Vectored Interrupt Controller (NVIC).
  - ◆ Hardware floating-point unit.
  - ◆ Non-maskable Interrupt (NMI) input.
  - ◆ JTAG and Serial Wire Debug (SWD), serial trace, eight breakpoints, and four watch points.
  - ◆ Enhanced Trace Module (ETM) and Enhanced Trace Buffer (ETB) support.
  - ◆ System tick timer.
- Cortex-M0 coprocessor



- ◆ ARM Cortex-M0 coprocessor capable of off-loading the main ARM Cortex-M4 processor.
- ◆ Running at frequencies of up to 204 MHz.
- ◆ JTAG and built-in NVIC.
- Cortex-M0 subsystem
  - ◆ ARM Cortex-M0 processor controlling the SPI and SGPIO peripherals residing on a separate AHB multilayer matrix with direct access to 2 kB + 16 kB of SRAM.
  - ◆ Running at frequencies of up to 204 MHz.
  - ◆ Connected via a core-to-core bridge to the main AHB multilayer matrix and the main ARM Cortex-M4 processor.
  - ◆ JTAG and built-in NVIC.
- On-chip memory
  - ◆ 264 kB SRAM for code and data use on the main AHB multilayer matrix plus 18 kB of SRAM on the Cortex-M0 subsystem.
  - ◆ Multiple SRAM blocks with separate bus access. Two SRAM blocks can be powered down individually.
  - ◆ 64 kB ROM containing boot code and on-chip software drivers.
  - ◆ 64-bit of One-Time Programmable (OTP) memory for general-purpose use.
  - ◆ Two banks (256 bit total) One-Time Programmable (OTP) memory for AES key storage. One bank can store an encrypted key for decoding the boot image.
- AES engine for encryption and decryption of the boot image and data with DMA support and programmable via a ROM-based API.
- Configurable digital peripherals
  - ◆ Serial GPIO (SGPIO) interface.
  - ◆ State Configurable Timer (SCT) subsystem on AHB.
  - ◆ Global Input Multiplexer Array (GIMA) allows to cross-connect multiple inputs and outputs to event driven peripherals like the timers, SCT, and ADC0/1.
- Serial interfaces
  - ◆ Quad SPI Flash Interface (SPIFI) with four lanes and up to 52 MB per second.
  - ◆ 10/100T Ethernet MAC with RMII and MII interfaces and DMA support for high throughput at low CPU load. Support for IEEE 1588 time stamping/advanced time stamping (IEEE 1588-2008 v2).
  - ◆ One High-speed USB 2.0 Host/Device/OTG interface with DMA support and on-chip high-speed PHY.
  - ◆ One High-speed USB 2.0 Host/Device interface with DMA support, on-chip full-speed PHY and ULPI interface to external high-speed PHY.
  - ◆ USB interface electrical test software included in ROM USB stack.
  - ◆ One 550 UART with DMA support and full modem interface.
  - ◆ Three 550 USARTs with DMA and synchronous mode support and a smart card interface conforming to ISO7816 specification. One USART with IrDA interface.
  - ◆ Two C\_CAN 2.0B controllers with one channel each. Use of C\_CAN controller excludes operation of all other peripherals connected to the same bus bridge. See [Figure 1](#) and [Ref. 1](#).
  - ◆ Two SSP controllers with FIFO and multi-protocol support. Both SSPs with DMA support.
  - ◆ One SPI controller.

- ◆ One Fast-mode Plus I<sup>2</sup>C-bus interface with monitor mode and with open-drain I/O pins conforming to the full I<sup>2</sup>C-bus specification. Supports data rates of up to 1 Mbit/s.
- ◆ One standard I<sup>2</sup>C-bus interface with monitor mode and with standard I/O pins.
- ◆ Two I<sup>2</sup>S interfaces, each with DMA support and with one input and one output.
- Digital peripherals
  - ◆ External Memory Controller (EMC) supporting external SRAM, ROM, NOR flash, and SDRAM devices.
  - ◆ LCD controller with DMA support and a programmable display resolution of up to 1024 H × 768 V. Supports monochrome and color STN panels and TFT color panels; supports 1/2/4/8 bpp Color Look-Up Table (CLUT) and 16/24-bit direct pixel mapping.
  - ◆ Secure Digital Input Output (SD/MMC) card interface.
  - ◆ Eight-channel General-Purpose DMA (GPDMA) controller can access all memories on the AHB and all DMA-capable AHB slaves.
  - ◆ 164 General-Purpose Input/Output (GPIO) pins with configurable pull-up/pull-down resistors and open-drain mode.
  - ◆ GPIO registers are located on the AHB for fast access. GPIO ports have DMA support.
  - ◆ Up to eight GPIO pins can be selected from all GPIO pins as edge and level sensitive interrupt sources.
  - ◆ Two GPIO group interrupt modules enable an interrupt based on a programmable pattern of input states of a group of GPIO pins.
  - ◆ Four general-purpose timer/counters with capture and match capabilities.
  - ◆ One motor control Pulse Width Modulator (PWM) for three-phase motor control.
  - ◆ One Quadrature Encoder Interface (QEI).
  - ◆ Repetitive Interrupt timer (RI timer).
  - ◆ Windowed watchdog timer (WWDT).
  - ◆ Ultra-low power Real-Time Clock (RTC) on separate power domain with 256 bytes of battery powered backup registers.
  - ◆ Alarm timer; can be battery powered.
- Analog peripherals
  - ◆ One 10-bit DAC with DMA support and a data conversion rate of 400 kSamples/s. LPGA256 package only.
  - ◆ Two 8-channel, 10-bit ADCs (ADC0/1) with DMA support and a data conversion rate of 400 kSamples/s for a total of 16 independent channels. The 10-bit ADCs are only available on the LPGA256 package.
  - ◆ One 6-channel, 12-bit high-speed ADC (ADCHS) with DMA support and a data conversion rate of 80 MSamples/s.
- Unique ID for each device.
- Clock generation unit
  - ◆ Crystal oscillator with an operating range of 1 MHz to 25 MHz.
  - ◆ 12 MHz Internal RC (IRC) oscillator trimmed to 1 % accuracy over temperature and voltage.
  - ◆ Ultra-low power Real-Time Clock (RTC) crystal oscillator.

- ◆ Three PLLs allow CPU operation up to the maximum CPU rate without the need for a high-frequency crystal. The second PLL is dedicated to the High-speed USB, the third PLL can be used as audio PLL.
- ◆ Clock output.
- Power
  - ◆ Single 3.3 V (2.2 V to 3.6 V) power supply with on-chip DC-to-DC converter for the core supply and the RTC power domain.
  - ◆ RTC power domain can be powered separately by a 3 V battery supply.
  - ◆ Four reduced power modes: Sleep, Deep-sleep, Power-down, and Deep power-down.
  - ◆ Processor wake-up from Sleep mode via wake-up interrupts from various peripherals.
  - ◆ Wake-up from Deep-sleep, Power-down, and Deep power-down modes via external interrupts and interrupts generated by battery powered blocks in the RTC power domain.
  - ◆ Brownout detect with four separate thresholds for interrupt and forced reset.
  - ◆ Power-On Reset (POR).
  - ◆ Available as LBG256 and TFBGA100 packages.

### 3. Applications

---

- Motor control
- Power management
- White goods
- RFID readers
- Embedded audio applications
- Industrial automation
- e-metering

## 4. Ordering information

Table 1. Ordering information

Type number	Package		Version
	Name	Description	
LPC43S70FET256	LBGA256	Plastic low profile ball grid array package; 256 balls; body 17 × 17 × 1 mm	SOT740-2
LPC43S70FET100	TFBGA100	Plastic thin fine-pitch ball grid array package; 100 balls; body 9 × 9 × 0.7 mm	SOT926-1

### 4.1 Ordering options

Table 2. Ordering options

Type number	Total SRAM	LCD	Ethernet	USB0 (Host, Device, OTG)	USB1 (Host, Device)/ULPI interface	10-bit ADC channels ADC0/ADC1	12-bit ADC channels	PWM	QEI	GPIO	Package
LPC43S70FET256	282 kB	yes	yes	yes	yes/yes	8/8	6	yes	yes	164	LBGA256
LPC43S70FET100	282 kB	no	yes	yes	yes/no	n/a	3	no	no	49	TFBGA100

5. Block diagram

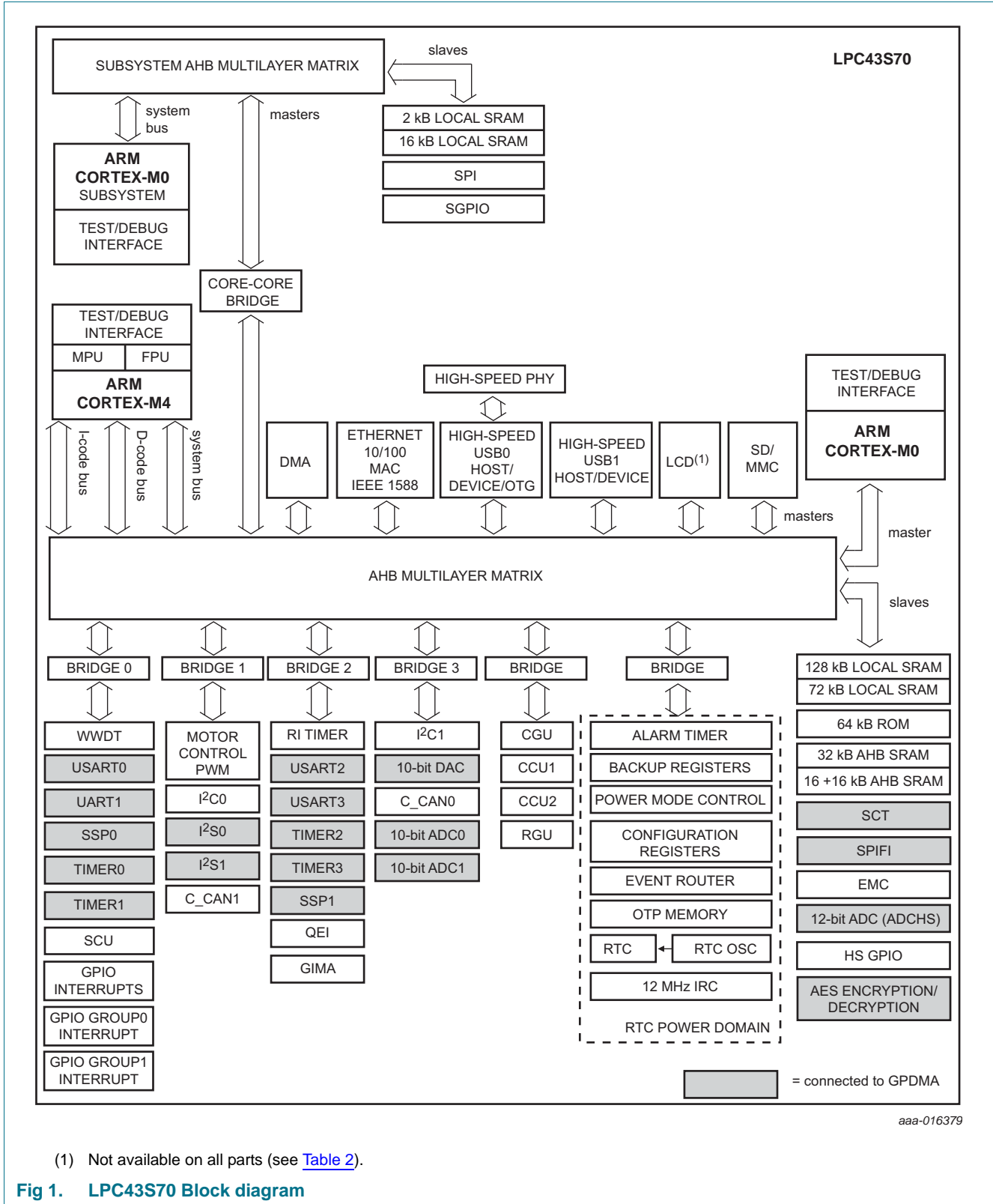

## 6. Pinning information

### 6.1 Pinning

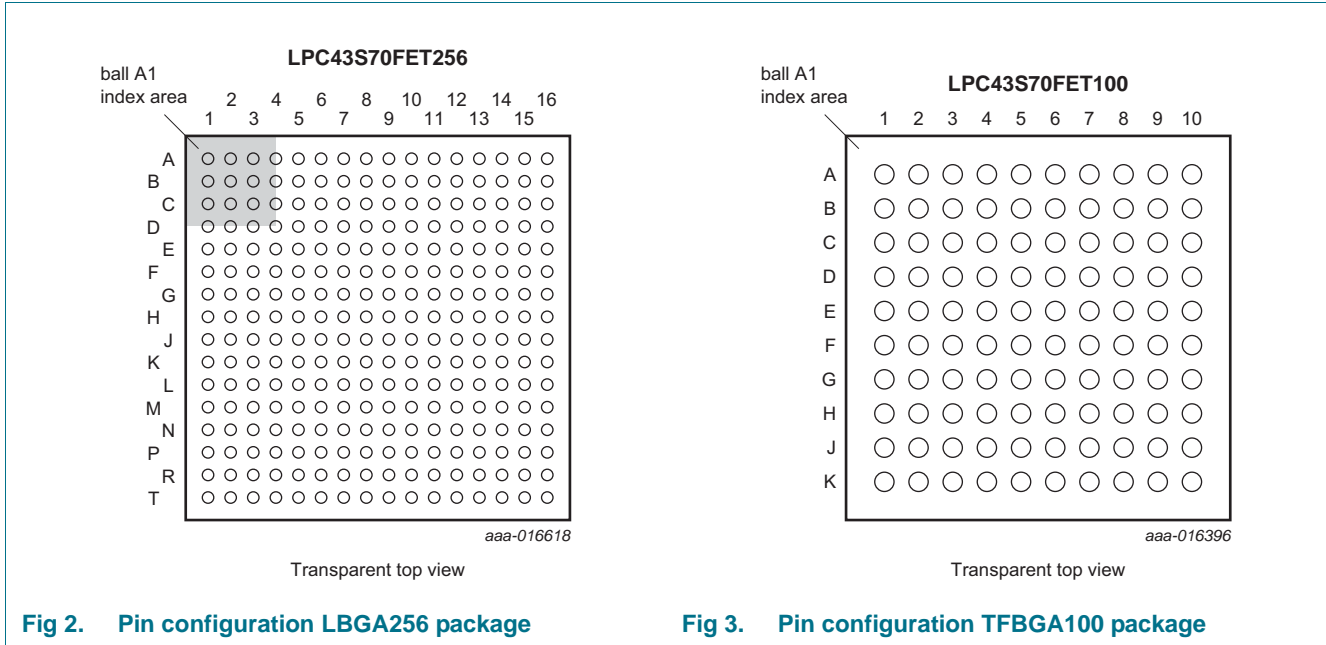

### 6.2 Pin description

On the LPC43S70, digital pins are grouped into 16 ports, named P0 to P9 and PA to PF, with up to 20 pins used per port. Each digital pin can support up to eight different digital functions, including General Purpose I/O (GPIO), selectable through the System Configuration Unit (SCU) registers. The pin name is not indicative of the GPIO port assigned to it.

Not all functions listed in [Table 3](#) are available on all packages. See [Table 2](#) for availability of USB0, USB1, Ethernet, and LCD functions.

**Table 3. Pin description**

LCD, Ethernet, USB0, and USB1 functions are not available on all parts. See [Table 2](#).

Symbol	LBGA256	TFBGA100	Reset state	Type	Description	
<b>Multiplexed digital pins</b>						
P0_0	L3	G2	3	I; PU	I/O	<b>GPIO0[0]</b> — General purpose digital input/output pin.
					I/O	<b>SSP1_MISO</b> — Master In Slave Out for SSP1.
					I	<b>ENET_RXD1</b> — Ethernet receive data 1 (RMII/MII interface).
					I/O	<b>SGPIO0</b> — General purpose digital input/output pin.
					-	R — Function reserved.
					-	R — Function reserved.
					I/O	<b>I2S0_TX_WS</b> — Transmit Word Select. It is driven by the master and received by the slave. Corresponds to the signal WS in the <i>I<sup>2</sup>S-bus specification</i> .
					I/O	<b>I2S1_TX_WS</b> — Transmit Word Select. It is driven by the master and received by the slave. Corresponds to the signal WS in the <i>I<sup>2</sup>S-bus specification</i> .
P0_1	M2	G1	3	I; PU	I/O	<b>GPIO0[1]</b> — General purpose digital input/output pin.
					I/O	<b>SSP1_MOSI</b> — Master Out Slave in for SSP1.
					I	<b>ENET_COL</b> — Ethernet Collision detect (MII interface).
					I/O	<b>SGPIO1</b> — General purpose digital input/output pin.
					-	R — Function reserved.
					-	R — Function reserved.
					I/O	<b>ENET_TX_EN</b> — Ethernet transmit enable (RMII/MII interface).
					I/O	<b>I2S1_TX_SDA</b> — I2S1 transmit data. It is driven by the transmitter and read by the receiver. Corresponds to the signal SD in the <i>I<sup>2</sup>S-bus specification</i> .
P1_0	P2	H1	3	I; PU	I/O	<b>GPIO0[4]</b> — General purpose digital input/output pin.
					I	<b>CTIN_3</b> — SCT input 3. Capture input 1 of timer 1.
					I/O	<b>EMC_A5</b> — External memory address line 5.
					-	R — Function reserved.
					-	R — Function reserved.
					I/O	<b>SSP0_SSEL</b> — Slave Select for SSP0.
					I/O	<b>SGPIO7</b> — General purpose digital input/output pin.
					-	R — Function reserved.
P1_1	R2	K2	3	I; PU	I/O	<b>GPIO0[8]</b> — General purpose digital input/output pin. Boot pin (see <a href="#">Table 5</a> ).
					O	<b>CTOUT_7</b> — SCT output 7. Match output 3 of timer 1.
					I/O	<b>EMC_A6</b> — External memory address line 6.
					I/O	<b>SGPIO8</b> — General purpose digital input/output pin.
					-	R — Function reserved.
					I/O	<b>SSP0_MISO</b> — Master In Slave Out for SSP0.
					-	R — Function reserved.
					-	R — Function reserved.

**Table 3. Pin description ...continued**LCD, Ethernet, USB0, and USB1 functions are not available on all parts. See [Table 2](#).

Symbol	LBGA256	TFBGA100	Reset state	Type	Description
P1_2	R3	K1	I; PU	I/O	<b>GPIO0[9]</b> — General purpose digital input/output pin. Boot pin (see <a href="#">Table 5</a> ).
					O <b>CTOUT_6</b> — SCT output 6. Match output 2 of timer 1.
					I/O <b>EMC_A7</b> — External memory address line 7.
					I/O <b>SGPIO9</b> — General purpose digital input/output pin.
					- <b>R</b> — Function reserved.
					I/O <b>SSP0_MOSI</b> — Master Out Slave in for SSP0.
					- <b>R</b> — Function reserved.
P1_3	P5	J1	I; PU	I/O	<b>GPIO0[10]</b> — General purpose digital input/output pin.
					O <b>CTOUT_8</b> — SCT output 8. Match output 0 of timer 2.
					I/O <b>SGPIO10</b> — General purpose digital input/output pin.
					O <b>EMC_OE</b> — LOW active Output Enable signal.
					O <b>USB0_IND1</b> — USB0 port indicator LED control output 1.
					I/O <b>SSP1_MISO</b> — Master In Slave Out for SSP1.
					- <b>R</b> — Function reserved.
P1_4	T3	J2	I; PU	I/O	<b>GPIO0[11]</b> — General purpose digital input/output pin.
					O <b>CTOUT_9</b> — SCT output 9. Match output 1 of timer 2.
					I/O <b>SGPIO11</b> — General purpose digital input/output pin.
					O <b>EMC_BLS0</b> — LOW active Byte Lane select signal 0.
					O <b>USB0_IND0</b> — USB0 port indicator LED control output 0.
					I/O <b>SSP1_MOSI</b> — Master Out Slave in for SSP1.
					- <b>R</b> — Function reserved.
P1_5	R5	J4	I; PU	I/O	<b>GPIO1[8]</b> — General purpose digital input/output pin.
					O <b>CTOUT_10</b> — SCT output 10. Match output 2 of timer 2.
					- <b>R</b> — Function reserved.
					O <b>EMC_CS0</b> — LOW active Chip Select 0 signal.
					I <b>USB0_PWR_FAULT</b> — Port power fault signal indicating overcurrent condition; this signal monitors over-current on the USB bus (external circuitry required to detect over-current condition).
					I/O <b>SSP1_SSEL</b> — Slave Select for SSP1.
					I/O <b>SGPIO15</b> — General purpose digital input/output pin.
O <b>SD_POW</b> — SD/MMC power monitor output.					

**Table 3. Pin description ...continued**LCD, Ethernet, USB0, and USB1 functions are not available on all parts. See [Table 2](#).

Symbol	LBGA256	TFBGA100	Reset state	Type	Description
P1_6	T4	K4	I; PU	I/O	<b>GPIO1[9]</b> — General purpose digital input/output pin.
					I <b>CTIN_5</b> — SCT input 5. Capture input 2 of timer 2.
					- <b>R</b> — Function reserved.
					O <b>EMC_WE</b> — LOW active Write Enable signal.
					- <b>R</b> — Function reserved.
					- <b>R</b> — Function reserved.
					I/O <b>SGPIO14</b> — General purpose digital input/output pin.
P1_7	T5	G4	I; PU	I/O	<b>GPIO1[0]</b> — General purpose digital input/output pin.
					I <b>U1_DSR</b> — Data Set Ready input for UART1.
					O <b>CTOUT_13</b> — SCT output 13. Match output 1 of timer 3.
					I/O <b>EMC_D0</b> — External memory data line 0.
					O <b>USB0_PPWR</b> — VBUS drive signal (towards external charge pump or power management unit); indicates that VBUS must be driven (active HIGH). Add a pull-down resistor to disable the power switch at reset. This signal has opposite polarity compared to the USB_PPWR used on other NXP LPC parts.
					- <b>R</b> — Function reserved.
					- <b>R</b> — Function reserved.
P1_8	R7	H5	I; PU	I/O	<b>GPIO1[1]</b> — General purpose digital input/output pin.
					O <b>U1_DTR</b> — Data Terminal Ready output for UART1.
					O <b>CTOUT_12</b> — SCT output 12. Match output 0 of timer 3.
					I/O <b>EMC_D1</b> — External memory data line 1.
					- <b>R</b> — Function reserved.
					- <b>R</b> — Function reserved.
					- <b>R</b> — Function reserved.
P1_9	T7	J5	I; PU	I/O	<b>GPIO1[2]</b> — General purpose digital input/output pin.
					O <b>U1_RTS</b> — Request to Send output for UART1.
					O <b>CTOUT_11</b> — SCT output 11. Match output 3 of timer 2.
					I/O <b>EMC_D2</b> — External memory data line 2.
					- <b>R</b> — Function reserved.
					- <b>R</b> — Function reserved.
					- <b>R</b> — Function reserved.
				I/O	<b>SD_DAT0</b> — SD/MMC data bus line 0.

**Table 3. Pin description ...continued**LCD, Ethernet, USB0, and USB1 functions are not available on all parts. See [Table 2](#).

Symbol	LBGA256	TFBGA100	Reset state	Type	Description
P1_10	R8	H6	I; PU	I/O	<b>GPIO1[3]</b> — General purpose digital input/output pin.
					I <b>U1_RI</b> — Ring Indicator input for UART1.
					O <b>CTOUT_14</b> — SCT output 14. Match output 2 of timer 3.
					I/O <b>EMC_D3</b> — External memory data line 3.
					- <b>R</b> — Function reserved.
					- <b>R</b> — Function reserved.
					- <b>R</b> — Function reserved.
P1_11	T9	J7	I; PU	I/O	<b>GPIO1[4]</b> — General purpose digital input/output pin.
					I <b>U1_CTS</b> — Clear to Send input for UART1.
					O <b>CTOUT_15</b> — SCT output 15. Match output 3 of timer 3.
					I/O <b>EMC_D4</b> — External memory data line 4.
					- <b>R</b> — Function reserved.
					- <b>R</b> — Function reserved.
					- <b>R</b> — Function reserved.
P1_12	R9	K7	I; PU	I/O	<b>GPIO1[5]</b> — General purpose digital input/output pin.
					I <b>U1_DCD</b> — Data Carrier Detect input for UART1.
					- <b>R</b> — Function reserved.
					I/O <b>EMC_D5</b> — External memory data line 5.
					I <b>T0_CAP1</b> — Capture input 1 of timer 0.
					- <b>R</b> — Function reserved.
					I/O <b>SGPIO8</b> — General purpose digital input/output pin.
P1_13	R10	H8	I; PU	I/O	<b>GPIO1[6]</b> — General purpose digital input/output pin.
					O <b>U1_TXD</b> — Transmitter output for UART1.
					- <b>R</b> — Function reserved.
					I/O <b>EMC_D6</b> — External memory data line 6.
					I <b>T0_CAP0</b> — Capture input 0 of timer 0.
					- <b>R</b> — Function reserved.
					I/O <b>SGPIO9</b> — General purpose digital input/output pin.
I <b>SD_CD</b> — SD/MMC card detect input.					

**Table 3. Pin description ...continued**LCD, Ethernet, USB0, and USB1 functions are not available on all parts. See [Table 2](#).

Symbol	LBGA256	TFBGA100	Reset state	Type	Description
P1_14	R11	J8	I; PU	I/O	<b>GPIO1[7]</b> — General purpose digital input/output pin.
					I <b>U1_RXD</b> — Receiver input for UART1.
					- <b>R</b> — Function reserved.
					I/O <b>EMC_D7</b> — External memory data line 7.
					O <b>T0_MAT2</b> — Match output 2 of timer 0.
					- <b>R</b> — Function reserved.
					I/O <b>SGPIO10</b> — General purpose digital input/output pin.
P1_15	T12	K8	I; PU	I/O	<b>GPIO0[2]</b> — General purpose digital input/output pin.
					O <b>U2_TXD</b> — Transmitter output for USART2.
					I/O <b>SGPIO2</b> — General purpose digital input/output pin.
					I <b>ENET_RXD0</b> — Ethernet receive data 0 (RMII/MII interface).
					O <b>T0_MAT1</b> — Match output 1 of timer 0.
					- <b>R</b> — Function reserved.
					- <b>R</b> — Function reserved.
P1_16	M7	H9	I; PU	I/O	<b>GPIO0[3]</b> — General purpose digital input/output pin.
					I <b>U2_RXD</b> — Receiver input for USART2.
					I/O <b>SGPIO3</b> — General purpose digital input/output pin.
					I <b>ENET_CRS</b> — Ethernet Carrier Sense (MII interface).
					O <b>T0_MAT0</b> — Match output 0 of timer 0.
					- <b>R</b> — Function reserved.
					- <b>R</b> — Function reserved.
P1_17	M8	H10	I; PU	I/O	<b>GPIO0[12]</b> — General purpose digital input/output pin.
					I/O <b>U2_UCLK</b> — Serial clock input/output for USART2 in synchronous mode.
					- <b>R</b> — Function reserved.
					I/O <b>ENET_MDIO</b> — Ethernet MIIM data input and output.
					I <b>T0_CAP3</b> — Capture input 3 of timer 0.
					O <b>CAN1_TD</b> — CAN1 transmitter output.
					I/O <b>SGPIO11</b> — General purpose digital input/output pin.
- <b>R</b> — Function reserved.					

**Table 3. Pin description ...continued**LCD, Ethernet, USB0, and USB1 functions are not available on all parts. See [Table 2](#).

Symbol	LPGA256	TFBGA100	Reset state	Type	Description
P1_18	N12	J10	I; PU	I/O	<b>GPIO0[13]</b> — General purpose digital input/output pin.
					I/O <b>U2_DIR</b> — RS-485/EIA-485 output enable/direction control for USART2.
					- <b>R</b> — Function reserved.
					O <b>ENET_TXD0</b> — Ethernet transmit data 0 (RMII/MII interface).
					O <b>T0_MAT3</b> — Match output 3 of timer 0.
					I <b>CAN1_RD</b> — CAN1 receiver input.
					I/O <b>SGPIO12</b> — General purpose digital input/output pin.
P1_19	M11	K9	I; PU	I	<b>ENET_TX_CLK (ENET_REF_CLK)</b> — Ethernet Transmit Clock (MII interface) or Ethernet Reference Clock (RMII interface).
					I/O <b>SSP1_SCK</b> — Serial clock for SSP1.
					- <b>R</b> — Function reserved.
					- <b>R</b> — Function reserved.
					O <b>CLKOUT</b> — Clock output pin.
					- <b>R</b> — Function reserved.
					O <b>I2S0_RX_MCLK</b> — I2S receive master clock.
P1_20	M10	K10	I; PU	I/O	<b>GPIO0[15]</b> — General purpose digital input/output pin.
					I/O <b>SSP1_SSEL</b> — Slave Select for SSP1.
					- <b>R</b> — Function reserved.
					O <b>ENET_TXD1</b> — Ethernet transmit data 1 (RMII/MII interface).
					I <b>T0_CAP2</b> — Capture input 2 of timer 0.
					- <b>R</b> — Function reserved.
					I/O <b>SGPIO13</b> — General purpose digital input/output pin.
P2_0	T16	G10	I; PU	I/O	<b>SGPIO4</b> — General purpose digital input/output pin.
					O <b>U0_TXD</b> — Transmitter output for USART0.
					I/O <b>EMC_A13</b> — External memory address line 13.
					O <b>USB0_PPWR</b> — VBUS drive signal (towards external charge pump or power management unit); indicates that VBUS must be driven (active HIGH). Add a pull-down resistor to disable the power switch at reset. This signal has opposite polarity compared to the USB_PPWR used on other NXP LPC parts.
					I/O <b>GPIO5[0]</b> — General purpose digital input/output pin.
					- <b>R</b> — Function reserved.
					I <b>T3_CAP0</b> — Capture input 0 of timer 3.
O <b>ENET_MDC</b> — Ethernet MIIM clock.					

**Table 3. Pin description ...continued**LCD, Ethernet, USB0, and USB1 functions are not available on all parts. See [Table 2](#).

Symbol	LBGA256	TFBGA100	Reset state	Type	Description
P2_1	N15	G7	[3]	I; PU	I/O <b>SGPIO5</b> — General purpose digital input/output pin.
					I <b>U0_RXD</b> — Receiver input for USART0.
					I/O <b>EMC_A12</b> — External memory address line 12.
					I <b>USB0_PWR_FAULT</b> — Port power fault signal indicating overcurrent condition; this signal monitors over-current on the USB bus (external circuitry required to detect over-current condition).
					I/O <b>GPIO5[1]</b> — General purpose digital input/output pin.
					- <b>R</b> — Function reserved.
					I <b>T3_CAP1</b> — Capture input 1 of timer 3.
					- <b>R</b> — Function reserved.
P2_2	M15	F5	[3]	I; PU	I/O <b>SGPIO6</b> — General purpose digital input/output pin.
					I/O <b>U0_UCLK</b> — Serial clock input/output for USART0 in synchronous mode.
					I/O <b>EMC_A11</b> — External memory address line 11.
					O <b>USB0_IND1</b> — USB0 port indicator LED control output 1.
					I/O <b>GPIO5[2]</b> — General purpose digital input/output pin.
					I <b>CTIN_6</b> — SCT input 6. Capture input 1 of timer 3.
					I <b>T3_CAP2</b> — Capture input 2 of timer 3.
					- <b>R</b> — Function reserved.
P2_3	J12	D8	[4]	I; PU	I/O <b>SGPIO12</b> — General purpose digital input/output pin.
					I/O <b>I2C1_SDA</b> — I <sup>2</sup> C1 data input/output (this pin does not use a specialized I <sup>2</sup> C pad).
					O <b>U3_TXD</b> — Transmitter output for USART3.
					I <b>CTIN_1</b> — SCT input 1. Capture input 1 of timer 0. Capture input 1 of timer 2.
					I/O <b>GPIO5[3]</b> — General purpose digital input/output pin.
					- <b>R</b> — Function reserved.
					O <b>T3_MAT0</b> — Match output 0 of timer 3.
					I <b>USB0_PWR_EN</b> — VBUS drive signal (towards external charge pump or power management unit); indicates that Vbus must be driven (active HIGH).
P2_4	K11	D9	[4]	I; PU	I/O <b>SGPIO13</b> — General purpose digital input/output pin.
					I/O <b>I2C1_SCL</b> — I <sup>2</sup> C1 clock input/output (this pin does not use a specialized I <sup>2</sup> C pad).
					I <b>U3_RXD</b> — Receiver input for USART3.
					I <b>CTIN_0</b> — SCT input 0. Capture input 0 of timer 0, 1, 2, 3.
					I/O <b>GPIO5[4]</b> — General purpose digital input/output pin.
					- <b>R</b> — Function reserved.
					O <b>T3_MAT1</b> — Match output 1 of timer 3.
					I <b>USB0_PWR_FAULT</b> — Port power fault signal indicating overcurrent condition; this signal monitors over-current on the USB bus (external circuitry required to detect over-current condition).

**Table 3. Pin description ...continued**LCD, Ethernet, USB0, and USB1 functions are not available on all parts. See [Table 2](#).

Symbol	LBGA256	TFBGA100	Reset state	Type	Description	
P2_5	K14	D10	[4]	I; PU	I/O	<b>SGPIO14</b> — General purpose digital input/output pin.
					I	<b>CTIN_2</b> — SCT input 2. Capture input 2 of timer 0.
					I	<b>USB1_VBUS</b> — Monitors the presence of USB1 bus power. <b>Note:</b> This signal must be HIGH for USB reset to occur.
					I	<b>ADCTRIG1</b> — ADC trigger input 1.
					I/O	<b>GPIO5[5]</b> — General purpose digital input/output pin.
					-	<b>R</b> — Function reserved.
					O	<b>T3_MAT2</b> — Match output 2 of timer 3.
					O	<b>USB0_IND0</b> — USB0 port indicator LED control output 0.
P2_6	K16	G9	[3]	I; PU	I/O	<b>SGPIO7</b> — General purpose digital input/output pin.
					I/O	<b>U0_DIR</b> — RS-485/EIA-485 output enable/direction control for USART0.
					I/O	<b>EMC_A10</b> — External memory address line 10.
					O	<b>USB0_IND0</b> — USB0 port indicator LED control output 0.
					I/O	<b>GPIO5[6]</b> — General purpose digital input/output pin.
					I	<b>CTIN_7</b> — SCT input 7.
					I	<b>T3_CAP3</b> — Capture input 3 of timer 3.
					-	<b>R</b> — Function reserved.
P2_7	H14	C10	[3]	I; PU	I/O	<b>GPIO0[7]</b> — General purpose digital input/output pin. If this pin is pulled LOW at reset, the part enters ISP mode using USART0.
					O	<b>CTOUT_1</b> — SCT output 1. Match output 1 of timer 0.
					I/O	<b>U3_UCLK</b> — Serial clock input/output for USART3 in synchronous mode.
					I/O	<b>EMC_A9</b> — External memory address line 9.
					-	<b>R</b> — Function reserved.
					-	<b>R</b> — Function reserved.
					O	<b>T3_MAT3</b> — Match output 3 of timer 3.
					-	<b>R</b> — Function reserved.
P2_8	J16	C6	[3]	I; PU	I/O	<b>SGPIO15</b> — General purpose digital input/output pin. Boot pin (see <a href="#">Table 5</a> ).
					O	<b>CTOUT_0</b> — SCT output 0. Match output 0 of timer 0.
					I/O	<b>U3_DIR</b> — RS-485/EIA-485 output enable/direction control for USART3.
					I/O	<b>EMC_A8</b> — External memory address line 8.
					I/O	<b>GPIO5[7]</b> — General purpose digital input/output pin.
					-	<b>R</b> — Function reserved.
					-	<b>R</b> — Function reserved.
					-	<b>R</b> — Function reserved.

**Table 3. Pin description ...continued**

LCD, Ethernet, USB0, and USB1 functions are not available on all parts. See [Table 2](#).

Symbol	LBGA256	TFBGA100	Reset state	Type	Description
P2_9	H16	B10	I; PU	I/O	<a href="#">3</a> <a href="#">2</a> <b>GPIO1[10]</b> — General purpose digital input/output pin. Boot pin (see <a href="#">Table 5</a> ).
					O <b>CTOUT_3</b> — SCT output 3. Match output 3 of timer 0.
					I/O <b>U3_BAUD</b> — Baud pin for USART3.
					I/O <b>EMC_A0</b> — External memory address line 0.
					- <b>R</b> — Function reserved.
					- <b>R</b> — Function reserved.
					- <b>R</b> — Function reserved.
P2_10	G16	E8	I; PU	I/O	<a href="#">3</a> <b>GPIO0[14]</b> — General purpose digital input/output pin.
					O <b>CTOUT_2</b> — SCT output 2. Match output 2 of timer 0.
					O <b>U2_TXD</b> — Transmitter output for USART2.
					I/O <b>EMC_A1</b> — External memory address line 1.
					- <b>R</b> — Function reserved.
					- <b>R</b> — Function reserved.
					- <b>R</b> — Function reserved.
P2_11	F16	A9	I; PU	I/O	<a href="#">3</a> <b>GPIO1[11]</b> — General purpose digital input/output pin.
					O <b>CTOUT_5</b> — SCT output 5. Match output 1 of timer 1.
					I <b>U2_RXD</b> — Receiver input for USART2.
					I/O <b>EMC_A2</b> — External memory address line 2.
					- <b>R</b> — Function reserved.
					- <b>R</b> — Function reserved.
					- <b>R</b> — Function reserved.
P2_12	E15	B9	I; PU	I/O	<a href="#">3</a> <b>GPIO1[12]</b> — General purpose digital input/output pin.
					O <b>CTOUT_4</b> — SCT output 4. Match output 0 of timer 1.
					- <b>R</b> — Function reserved.
					I/O <b>EMC_A3</b> — External memory address line 3.
					- <b>R</b> — Function reserved.
					- <b>R</b> — Function reserved.
					- <b>R</b> — Function reserved.
					I/O <b>U2_UCLK</b> — Serial clock input/output for USART2 in synchronous mode.

**Table 3. Pin description ...continued**

LCD, Ethernet, USB0, and USB1 functions are not available on all parts. See [Table 2](#).

Symbol	LPGA256	TFBGA100	Reset state	Type	Description					
P2_13	C16	A10	I; PU	I/O	<b>GPIO1[13]</b> — General purpose digital input/output pin.					
					I <b>CTIN_4</b> — SCT input 4. Capture input 2 of timer 1.					
					- <b>R</b> — Function reserved.					
					I/O <b>EMC_A4</b> — External memory address line 4.					
					- <b>R</b> — Function reserved.					
					- <b>R</b> — Function reserved.					
					- <b>R</b> — Function reserved.					
P3_0	F13	A8	I; PU	I/O	<b>I2S0_RX_SCK</b> — I2S receive clock. It is driven by the master and received by the slave. Corresponds to the signal SCK in the <i>I<sup>2</sup>S-bus specification</i> .					
					O <b>I2S0_RX_MCLK</b> — I2S receive master clock.					
					I/O <b>I2S0_TX_SCK</b> — Transmit Clock. It is driven by the master and received by the slave. Corresponds to the signal SCK in the <i>I<sup>2</sup>S-bus specification</i> .					
					O <b>I2S0_TX_MCLK</b> — I2S transmit master clock.					
					I/O <b>SSP0_SCK</b> — Serial clock for SSP0.					
					- <b>R</b> — Function reserved.					
					- <b>R</b> — Function reserved.					
P3_1	G11	F7	I; PU	I/O	<b>I2S0_TX_WS</b> — Transmit Word Select. It is driven by the master and received by the slave. Corresponds to the signal WS in the <i>I<sup>2</sup>S-bus specification</i> .					
					I/O <b>I2S0_RX_WS</b> — Receive Word Select. It is driven by the master and received by the slave. Corresponds to the signal WS in the <i>I<sup>2</sup>S-bus specification</i> .					
					I <b>CAN0_RD</b> — CAN receiver input.					
					O <b>USB1_IND1</b> — USB1 Port indicator LED control output 1.					
					I/O <b>GPIO5[8]</b> — General purpose digital input/output pin.					
					- <b>R</b> — Function reserved.					
					O <b>LCD_VD15</b> — LCD data.					
					- <b>R</b> — Function reserved.					
					P3_2	F11	G6	I; PU	I/O	<b>I2S0_TX_SDA</b> — I2S transmit data. It is driven by the transmitter and read by the receiver. Corresponds to the signal SD in the <i>I<sup>2</sup>S-bus specification</i> .
										I/O <b>I2S0_RX_SDA</b> — I2S Receive data. It is driven by the transmitter and read by the receiver. Corresponds to the signal SD in the <i>I<sup>2</sup>S-bus specification</i> .
O <b>CAN0_TD</b> — CAN transmitter output.										
O <b>USB1_IND0</b> — USB1 Port indicator LED control output 0.										
I/O <b>GPIO5[9]</b> — General purpose digital input/output pin.										
- <b>R</b> — Function reserved.										
O <b>LCD_VD14</b> — LCD data.										
- <b>R</b> — Function reserved.										

**Table 3. Pin description ...continued**

LCD, Ethernet, USB0, and USB1 functions are not available on all parts. See [Table 2](#).

Symbol	LBGA256	TFBGA100	Reset state	Type	Description
P3_3	B14	A7	5	I; PU	- R — Function reserved.
					I/O <b>SPI_SCK</b> — Serial clock for SPI.
					I/O <b>SSP0_SCK</b> — Serial clock for SSP0.
					O <b>SPIFI_SCK</b> — Serial clock for SPIFI.
					O <b>CGU_OUT1</b> — CGU spare clock output 1.
					- R — Function reserved.
					O <b>I2S0_TX_MCLK</b> — I2S transmit master clock.
P3_4	A15	B8	3	I; PU	I/O <b>GPIO1[14]</b> — General purpose digital input/output pin.
					- R — Function reserved.
					- R — Function reserved.
					I/O <b>SPIFI_SIO3</b> — I/O lane 3 for SPIFI.
					O <b>U1_TXD</b> — Transmitter output for UART 1.
					I/O <b>I2S0_TX_WS</b> — Transmit Word Select. It is driven by the master and received by the slave. Corresponds to the signal WS in the <i>I<sup>2</sup>S-bus specification</i> .
					I/O <b>I2S1_RX_SDA</b> — I2S1 Receive data. It is driven by the transmitter and read by the receiver. Corresponds to the signal SD in the <i>I<sup>2</sup>S-bus specification</i> .
P3_5	C12	B7	3	I; PU	O <b>LCD_VD13</b> — LCD data.
					I/O <b>GPIO1[15]</b> — General purpose digital input/output pin.
					- R — Function reserved.
					- R — Function reserved.
					I/O <b>SPIFI_SIO2</b> — I/O lane 2 for SPIFI.
					I <b>U1_RXD</b> — Receiver input for UART 1.
					I/O <b>I2S0_TX_SDA</b> — I2S transmit data. It is driven by the transmitter and read by the receiver. Corresponds to the signal SD in the <i>I<sup>2</sup>S-bus specification</i> .
I/O <b>I2S1_RX_WS</b> — Receive Word Select. It is driven by the master and received by the slave. Corresponds to the signal WS in the <i>I<sup>2</sup>S-bus specification</i> .					
P3_6	B13	C7	3	I; PU	O <b>LCD_VD12</b> — LCD data.
					I/O <b>GPIO0[6]</b> — General purpose digital input/output pin.
					I/O <b>SPI_MISO</b> — Master In Slave Out for SPI.
					I/O <b>SSP0_SSEL</b> — Slave Select for SSP0.
					I/O <b>SPIFI_MISO</b> — Input 1 in SPIFI quad mode; SPIFI output IO1.
					- R — Function reserved.
					I/O <b>SSP0_MISO</b> — Master In Slave Out for SSP0.
- R — Function reserved.					
- R — Function reserved.					

**Table 3. Pin description ...continued**LCD, Ethernet, USB0, and USB1 functions are not available on all parts. See [Table 2](#).

Symbol	LBGA256	TFBGA100	Reset state	Type	Description				
P3_7	C11	D7	[3] I; PU	-	R — Function reserved.				
				I/O	<b>SPI_MOSI</b> — Master Out Slave In for SPI.				
				I/O	<b>SSP0_MISO</b> — Master In Slave Out for SSP0.				
				I/O	<b>SPIFI_MOSI</b> — Input I0 in SPIFI quad mode; SPIFI output IO0.				
				I/O	<b>GPIO5[10]</b> — General purpose digital input/output pin.				
				I/O	<b>SSP0_MOSI</b> — Master Out Slave in for SSP0.				
				-	R — Function reserved.				
P3_8	C10	E7	[3] I; PU	-	R — Function reserved.				
				I	<b>SPI_SSEL</b> — Slave Select for SPI. Note that this pin is an input pin only. The SPI in master mode cannot drive the CS input on the slave. Any GPIO pin can be used for SPI chip select in master mode.				
				I/O	<b>SSP0_MOSI</b> — Master Out Slave in for SSP0.				
				I/O	<b>SPIFI_CS</b> — SPIFI serial flash chip select.				
				I/O	<b>GPIO5[11]</b> — General purpose digital input/output pin.				
				I/O	<b>SSP0_SSEL</b> — Slave Select for SSP0.				
				-	R — Function reserved.				
				-	R — Function reserved.				
				P4_0	D5	-	[3] I; PU	I/O	<b>GPIO2[0]</b> — General purpose digital input/output pin.
								O	<b>MCOA0</b> — Motor control PWM channel 0, output A.
I	<b>NMI</b> — External interrupt input to NMI.								
-	R — Function reserved.								
-	R — Function reserved.								
O	<b>LCD_VD13</b> — LCD data.								
I/O	<b>U3_UCLK</b> — Serial clock input/output for USART3 in synchronous mode.								
-	R — Function reserved.								
P4_1	A1	-	[6] [13] I; PU					I/O	<b>GPIO2[1]</b> — General purpose digital input/output pin.
				O	<b>CTOUT_1</b> — SCT output 1. Match output 1 of timer 0.				
				O	<b>LCD_VD0</b> — LCD data.				
				-	R — Function reserved.				
				-	R — Function reserved.				
				O	<b>LCD_VD19</b> — LCD data.				
				O	<b>U3_TXD</b> — Transmitter output for USART3.				
				I	<b>ENET_COL</b> — Ethernet Collision detect (MII interface).				
				AI	<b>ADC0_1</b> — ADC0, input channel 1. Configure the pin as GPIO input and use the ADC function select register in the SCU to select the ADC.				

**Table 3. Pin description ...continued**

LCD, Ethernet, USB0, and USB1 functions are not available on all parts. See [Table 2](#).

Symbol	LBGA256	TFBGA100	Reset state	Type	Description	
P4_2	D3	-	[3]	I; PU	I/O	<b>GPIO2[2]</b> — General purpose digital input/output pin.
					O	<b>CTOUT_0</b> — SCT output 0. Match output 0 of timer 0.
					O	<b>LCD_VD3</b> — LCD data.
					-	<b>R</b> — Function reserved.
					-	<b>R</b> — Function reserved.
					O	<b>LCD_VD12</b> — LCD data.
					I	<b>U3_RXD</b> — Receiver input for USART3.
					I/O	<b>SGPIO8</b> — General purpose digital input/output pin.
P4_3	C2	-	[6] [13]	I; PU	I/O	<b>GPIO2[3]</b> — General purpose digital input/output pin.
					O	<b>CTOUT_3</b> — SCT output 3. Match output 3 of timer 0.
					O	<b>LCD_VD2</b> — LCD data.
					-	<b>R</b> — Function reserved.
					-	<b>R</b> — Function reserved.
					O	<b>LCD_VD21</b> — LCD data.
					I/O	<b>U3_BAUD</b> — Baud pin for USART3.
					I/O	<b>SGPIO9</b> — General purpose digital input/output pin.
P4_4	B1	-	[6]	I; PU	I/O	<b>GPIO2[4]</b> — General purpose digital input/output pin.
					O	<b>CTOUT_2</b> — SCT output 2. Match output 2 of timer 0.
					O	<b>LCD_VD1</b> — LCD data.
					-	<b>R</b> — Function reserved.
					-	<b>R</b> — Function reserved.
					O	<b>LCD_VD20</b> — LCD data.
					I/O	<b>U3_DIR</b> — RS-485/EIA-485 output enable/direction control for USART3.
					I/O	<b>SGPIO10</b> — General purpose digital input/output pin.
P4_5	D2	-	[3]	I; PU	I/O	<b>GPIO2[5]</b> — General purpose digital input/output pin.
					O	<b>CTOUT_5</b> — SCT output 5. Match output 1 of timer 1.
					O	<b>LCD_FP</b> — Frame pulse (STN). Vertical synchronization pulse (TFT).
					-	<b>R</b> — Function reserved.
					-	<b>R</b> — Function reserved.
					-	<b>R</b> — Function reserved.
					-	<b>R</b> — Function reserved.
					I/O	<b>SGPIO11</b> — General purpose digital input/output pin.

**Table 3. Pin description ...continued**

LCD, Ethernet, USB0, and USB1 functions are not available on all parts. See [Table 2](#).

Symbol	LBGA256	TFBGA100	Reset state	Type	Description					
P4_6	C1	-	[3] I; PU	I/O	<b>GPIO2[6]</b> — General purpose digital input/output pin.					
					O <b>CTOUT_4</b> — SCT output 4. Match output 0 of timer 1.					
					O <b>LCD_ENAB/LCDM</b> — STN AC bias drive or TFT data enable input.					
					- <b>R</b> — Function reserved.					
					- <b>R</b> — Function reserved.					
					- <b>R</b> — Function reserved.					
					- <b>R</b> — Function reserved.					
P4_7	H4	-	[3] O; PU	O	<b>LCD_DCLK</b> — LCD panel clock.					
					I <b>GP_CLKIN</b> — General purpose clock input to the CGU.					
					- <b>R</b> — Function reserved.					
					- <b>R</b> — Function reserved.					
					- <b>R</b> — Function reserved.					
					- <b>R</b> — Function reserved.					
					I/O <b>I2S1_TX_SCK</b> — Transmit Clock. It is driven by the master and received by the slave. Corresponds to the signal SCK in the I <sup>2</sup> S-bus specification.					
					I/O <b>I2S0_TX_SCK</b> — Transmit Clock. It is driven by the master and received by the slave. Corresponds to the signal SCK in the I <sup>2</sup> S-bus specification.					
					P4_8	E2	-	[3] I; PU	-	<b>R</b> — Function reserved.
										I <b>CTIN_5</b> — SCT input 5. Capture input 2 of timer 2.
O <b>LCD_VD9</b> — LCD data.										
- <b>R</b> — Function reserved.										
I/O <b>GPIO5[12]</b> — General purpose digital input/output pin.										
O <b>LCD_VD22</b> — LCD data.										
O <b>CAN1_TD</b> — CAN1 transmitter output.										
I/O <b>SGPIO13</b> — General purpose digital input/output pin.										
P4_9	L2	-	[3] I; PU	-	<b>R</b> — Function reserved.					
					I <b>CTIN_6</b> — SCT input 6. Capture input 1 of timer 3.					
					O <b>LCD_VD11</b> — LCD data.					
					- <b>R</b> — Function reserved.					
					I/O <b>GPIO5[13]</b> — General purpose digital input/output pin.					
					O <b>LCD_VD15</b> — LCD data.					
					I <b>CAN1_RD</b> — CAN1 receiver input.					
					I/O <b>SGPIO14</b> — General purpose digital input/output pin.					

**Table 3. Pin description ...continued**LCD, Ethernet, USB0, and USB1 functions are not available on all parts. See [Table 2](#).

Symbol	LBGA256	TFBGA100	Reset state	Type	Description
P4_10	M3	-	③	I; PU	- R — Function reserved.
					I <b>CTIN_2</b> — SCT input 2. Capture input 2 of timer 0.
					O <b>LCD_VD10</b> — LCD data.
					- R — Function reserved.
					I/O <b>GPIO5[14]</b> — General purpose digital input/output pin.
					O <b>LCD_VD14</b> — LCD data.
					- R — Function reserved.
P5_0	N3	-	③	I; PU	I/O <b>GPIO2[9]</b> — General purpose digital input/output pin.
					O <b>MCOB2</b> — Motor control PWM channel 2, output B.
					I/O <b>EMC_D12</b> — External memory data line 12.
					- R — Function reserved.
					I <b>U1_DSR</b> — Data Set Ready input for UART 1.
					I <b>T1_CAP0</b> — Capture input 0 of timer 1.
					- R — Function reserved.
P5_1	P3	-	③	I; PU	I/O <b>GPIO2[10]</b> — General purpose digital input/output pin.
					I <b>MCI2</b> — Motor control PWM channel 2, input.
					I/O <b>EMC_D13</b> — External memory data line 13.
					- R — Function reserved.
					O <b>U1_DTR</b> — Data Terminal Ready output for UART 1. Can also be configured to be an RS-485/EIA-485 output enable signal for UART 1.
					I <b>T1_CAP1</b> — Capture input 1 of timer 1.
					- R — Function reserved.
P5_2	R4	-	③	I; PU	I/O <b>GPIO2[11]</b> — General purpose digital input/output pin.
					I <b>MCI1</b> — Motor control PWM channel 1, input.
					I/O <b>EMC_D14</b> — External memory data line 14.
					- R — Function reserved.
					O <b>U1_RTS</b> — Request to Send output for UART 1. Can also be configured to be an RS-485/EIA-485 output enable signal for UART 1.
					I <b>T1_CAP2</b> — Capture input 2 of timer 1.
					- R — Function reserved.
- R — Function reserved.					

**Table 3. Pin description ...continued**LCD, Ethernet, USB0, and USB1 functions are not available on all parts. See [Table 2](#).

Symbol	LPGA256	TFBGA100	Reset state	Type	Description
P5_3	T8	-	[3]	I; PU	I/O <b>GPIO2[12]</b> — General purpose digital input/output pin.
					I <b>MCIO</b> — Motor control PWM channel 0, input.
					I/O <b>EMC_D15</b> — External memory data line 15.
					- <b>R</b> — Function reserved.
					I <b>U1_RI</b> — Ring Indicator input for UART 1.
					I <b>T1_CAP3</b> — Capture input 3 of timer 1.
					- <b>R</b> — Function reserved.
P5_4	P9	-	[3]	I; PU	I/O <b>GPIO2[13]</b> — General purpose digital input/output pin.
					O <b>MCOB0</b> — Motor control PWM channel 0, output B.
					I/O <b>EMC_D8</b> — External memory data line 8.
					- <b>R</b> — Function reserved.
					I <b>U1_CTS</b> — Clear to Send input for UART 1.
					O <b>T1_MAT0</b> — Match output 0 of timer 1.
					- <b>R</b> — Function reserved.
P5_5	P10	-	[3]	I; PU	I/O <b>GPIO2[14]</b> — General purpose digital input/output pin.
					O <b>MCOA1</b> — Motor control PWM channel 1, output A.
					I/O <b>EMC_D9</b> — External memory data line 9.
					- <b>R</b> — Function reserved.
					I <b>U1_DCD</b> — Data Carrier Detect input for UART 1.
					O <b>T1_MAT1</b> — Match output 1 of timer 1.
					- <b>R</b> — Function reserved.
P5_6	T13	-	[3]	I; PU	I/O <b>GPIO2[15]</b> — General purpose digital input/output pin.
					O <b>MCOB1</b> — Motor control PWM channel 1, output B.
					I/O <b>EMC_D10</b> — External memory data line 10.
					- <b>R</b> — Function reserved.
					O <b>U1_TXD</b> — Transmitter output for UART 1.
					O <b>T1_MAT2</b> — Match output 2 of timer 1.
					- <b>R</b> — Function reserved.
- <b>R</b> — Function reserved.					

**Table 3. Pin description ...continued**LCD, Ethernet, USB0, and USB1 functions are not available on all parts. See [Table 2](#).

Symbol	LBGA256	TFBGA100	Reset state	Type	Description
P5_7	R12	-	[3]	I; PU	I/O <b>GPIO2[7]</b> — General purpose digital input/output pin.
					O <b>MCOA2</b> — Motor control PWM channel 2, output A.
					I/O <b>EMC_D11</b> — External memory data line 11.
					- <b>R</b> — Function reserved.
					I <b>U1_RXD</b> — Receiver input for UART 1.
					O <b>T1_MAT3</b> — Match output 3 of timer 1.
					- <b>R</b> — Function reserved.
P6_0	M12	H7	[3]	I; PU	- <b>R</b> — Function reserved.
					O <b>I2S0_RX_MCLK</b> — I2S receive master clock.
					- <b>R</b> — Function reserved.
					- <b>R</b> — Function reserved.
					I/O <b>I2S0_RX_SCK</b> — Receive Clock. It is driven by the master and received by the slave. Corresponds to the signal SCK in the <i>I<sup>2</sup>S-bus specification</i> .
					- <b>R</b> — Function reserved.
					- <b>R</b> — Function reserved.
P6_1	R15	G5	[3]	I; PU	I/O <b>GPIO3[0]</b> — General purpose digital input/output pin.
					O <b>EMC_DYCS1</b> — SDRAM chip select 1.
					I/O <b>U0_UCLK</b> — Serial clock input/output for USART0 in synchronous mode.
					I/O <b>I2S0_RX_WS</b> — Receive Word Select. It is driven by the master and received by the slave. Corresponds to the signal WS in the <i>I<sup>2</sup>S-bus specification</i> .
					- <b>R</b> — Function reserved.
					I <b>T2_CAP0</b> — Capture input 2 of timer 2.
					- <b>R</b> — Function reserved.
P6_2	L13	J9	[3]	I; PU	I/O <b>GPIO3[1]</b> — General purpose digital input/output pin.
					O <b>EMC_CKEOUT1</b> — SDRAM clock enable 1.
					I/O <b>U0_DIR</b> — RS-485/EIA-485 output enable/direction control for USART0.
					I/O <b>I2S0_RX_SDA</b> — I2S Receive data. It is driven by the transmitter and read by the receiver. Corresponds to the signal SD in the <i>I<sup>2</sup>S-bus specification</i> .
					- <b>R</b> — Function reserved.
					I <b>T2_CAP1</b> — Capture input 1 of timer 2.
					- <b>R</b> — Function reserved.

**Table 3. Pin description ...continued**LCD, Ethernet, USB0, and USB1 functions are not available on all parts. See [Table 2](#).

Symbol	LPGA256	TFBGA100	Reset state	Type	Description	
P6_3	P15	-	[3]	I; PU	I/O	<b>GPIO3[2]</b> — General purpose digital input/output pin.
					I	<b>USB0_PWR_EN</b> — VBUS drive signal (towards external charge pump or power management unit); indicates that the VBUS signal must be driven (active HIGH).
					I/O	<b>SGPIO4</b> — General purpose digital input/output pin.
					O	<b>EMC_CS1</b> — LOW active Chip Select 1 signal.
					-	<b>R</b> — Function reserved.
					I	<b>T2_CAP2</b> — Capture input 2 of timer 2.
					-	<b>R</b> — Function reserved.
P6_4	R16	F6	[3]	I; PU	I/O	<b>GPIO3[3]</b> — General purpose digital input/output pin.
					I	<b>CTIN_6</b> — SCT input 6. Capture input 1 of timer 3.
					O	<b>U0_TXD</b> — Transmitter output for USART0.
					O	<b>EMC_CAS</b> — LOW active SDRAM Column Address Strobe.
					-	<b>R</b> — Function reserved.
					-	<b>R</b> — Function reserved.
					-	<b>R</b> — Function reserved.
P6_5	P16	F9	[3]	I; PU	I/O	<b>GPIO3[4]</b> — General purpose digital input/output pin.
					O	<b>CTOUT_6</b> — SCT output 6. Match output 2 of timer 1.
					I	<b>U0_RXD</b> — Receiver input for USART0.
					O	<b>EMC_RAS</b> — LOW active SDRAM Row Address Strobe.
					-	<b>R</b> — Function reserved.
					-	<b>R</b> — Function reserved.
					-	<b>R</b> — Function reserved.
P6_6	L14	-	[3]	I; PU	I/O	<b>GPIO0[5]</b> — General purpose digital input/output pin.
					O	<b>EMC_BLS1</b> — LOW active Byte Lane select signal 1.
					I/O	<b>SGPIO5</b> — General purpose digital input/output pin.
					I	<b>USB0_PWR_FAULT</b> — Port power fault signal indicating overcurrent condition; this signal monitors over-current on the USB bus (external circuitry required to detect over-current condition).
					-	<b>R</b> — Function reserved.
					I	<b>T2_CAP3</b> — Capture input 3 of timer 2.
					-	<b>R</b> — Function reserved.

**Table 3. Pin description ...continued**LCD, Ethernet, USB0, and USB1 functions are not available on all parts. See [Table 2](#).

Symbol	LBGA256	TFBGA100	Reset state	Type	Description
P6_7	J13	-	③	I; PU	- R — Function reserved.
					I/O <b>EMC_A15</b> — External memory address line 15.
					I/O <b>SGPIO6</b> — General purpose digital input/output pin.
					O <b>USB0_IND1</b> — USB0 port indicator LED control output 1.
					I/O <b>GPIO5[15]</b> — General purpose digital input/output pin.
					O <b>T2_MAT0</b> — Match output 0 of timer 2.
					- R — Function reserved.
P6_8	H13	-	③	I; PU	- R — Function reserved.
					I/O <b>EMC_A14</b> — External memory address line 14.
					I/O <b>SGPIO7</b> — General purpose digital input/output pin.
					O <b>USB0_IND0</b> — USB0 port indicator LED control output 0.
					I/O <b>GPIO5[16]</b> — General purpose digital input/output pin.
					O <b>T2_MAT1</b> — Match output 1 of timer 2.
					- R — Function reserved.
P6_9	J15	F8	③	I; PU	I/O <b>GPIO3[5]</b> — General purpose digital input/output pin.
					- R — Function reserved.
					- R — Function reserved.
					O <b>EMC_DYCS0</b> — SDRAM chip select 0.
					- R — Function reserved.
					O <b>T2_MAT2</b> — Match output 2 of timer 2.
					- R — Function reserved.
P6_10	H15	-	③	I; PU	I/O <b>GPIO3[6]</b> — General purpose digital input/output pin.
					O <b>MCABORT</b> — Motor control PWM, LOW-active fast abort.
					- R — Function reserved.
					O <b>EMC_DQMOUT1</b> — Data mask 1 used with SDRAM and static devices.
					- R — Function reserved.
					- R — Function reserved.
					- R — Function reserved.

**Table 3. Pin description ...continued**

LCD, Ethernet, USB0, and USB1 functions are not available on all parts. See [Table 2](#).

Symbol	LBGA256	TFBGA100	Reset state	Type	Description
P6_11	H12	C9	I; PU	I/O	<a href="#">3</a> <a href="#">2</a> <b>GPIO3[7]</b> — General purpose digital input/output pin.
					- R — Function reserved.
					- R — Function reserved.
					O <b>EMC_CKEOUT0</b> — SDRAM clock enable 0.
					- R — Function reserved.
					O <b>T2_MAT3</b> — Match output 3 of timer 2.
					- R — Function reserved.
P6_12	G15	-	I; PU	I/O	<a href="#">3</a> <b>GPIO2[8]</b> — General purpose digital input/output pin.
					O <b>CTOUT_7</b> — SCT output 7. Match output 3 of timer 1.
					- R — Function reserved.
					O <b>EMC_DQMOUT0</b> — Data mask 0 used with SDRAM and static devices.
					- R — Function reserved.
					- R — Function reserved.
					- R — Function reserved.
P7_0	B16	-	I; PU	I/O	<a href="#">3</a> <b>GPIO3[8]</b> — General purpose digital input/output pin.
					O <b>CTOUT_14</b> — SCT output 14. Match output 2 of timer 3.
					- R — Function reserved.
					O <b>LCD_LE</b> — Line end signal.
					- R — Function reserved.
					- R — Function reserved.
					- R — Function reserved.
P7_1	C14	-	I; PU	I/O	<a href="#">3</a> <b>GPIO3[9]</b> — General purpose digital input/output pin.
					O <b>CTOUT_15</b> — SCT output 15. Match output 3 of timer 3.
					I/O <b>I2S0_TX_WS</b> — Transmit Word Select. It is driven by the master and received by the slave. Corresponds to the signal WS in the <i>I<sup>2</sup>S-bus specification</i> .
					O <b>LCD_VD19</b> — LCD data.
					O <b>LCD_VD7</b> — LCD data.
					- R — Function reserved.
					O <b>U2_TXD</b> — Transmitter output for USART2.
					I/O <b>SGPIO5</b> — General purpose digital input/output pin.

**Table 3. Pin description ...continued**

LCD, Ethernet, USB0, and USB1 functions are not available on all parts. See [Table 2](#).

Symbol	LBGA256	TFBGA100	Reset state	Type	Description
P7_2	A16	-	[3] I; PU	[2]	I/O <b>GPIO3[10]</b> — General purpose digital input/output pin.
					I <b>CTIN_4</b> — SCT input 4. Capture input 2 of timer 1.
					I/O <b>I2S0_TX_SDA</b> — I2S transmit data. It is driven by the transmitter and read by the receiver. Corresponds to the signal SD in the <i>I<sup>2</sup>S-bus specification</i> .
					O <b>LCD_VD18</b> — LCD data.
					O <b>LCD_VD6</b> — LCD data.
					- <b>R</b> — Function reserved.
					I <b>U2_RXD</b> — Receiver input for USART2.
					I/O <b>SGPIO6</b> — General purpose digital input/output pin.
P7_3	C13	-	[3] I; PU	[3]	I/O <b>GPIO3[11]</b> — General purpose digital input/output pin.
					I <b>CTIN_3</b> — SCT input 3. Capture input 1 of timer 1.
					- <b>R</b> — Function reserved.
					O <b>LCD_VD17</b> — LCD data.
					O <b>LCD_VD5</b> — LCD data.
					- <b>R</b> — Function reserved.
					- <b>R</b> — Function reserved.
					- <b>R</b> — Function reserved.
P7_4	C8	-	[6] I; PU	[6]	I/O <b>GPIO3[12]</b> — General purpose digital input/output pin.
					O <b>CTOUT_13</b> — SCT output 13. Match output 1 of timer 3.
					- <b>R</b> — Function reserved.
					O <b>LCD_VD16</b> — LCD data.
					O <b>LCD_VD4</b> — LCD data.
					O <b>TRACEDATA[0]</b> — Trace data, bit 0.
					- <b>R</b> — Function reserved.
					- <b>R</b> — Function reserved.
P7_5	A7	-	[6] I; PU	[6]	I/O <b>GPIO3[13]</b> — General purpose digital input/output pin.
					O <b>CTOUT_12</b> — SCT output 12. Match output 0 of timer 3.
					- <b>R</b> — Function reserved.
					O <b>LCD_VD8</b> — LCD data.
					O <b>LCD_VD23</b> — LCD data.
					O <b>TRACEDATA[1]</b> — Trace data, bit 1.
					- <b>R</b> — Function reserved.
					- <b>R</b> — Function reserved.
AI					<b>ADC0_4</b> — ADC0, input channel 4. Configure the pin as GPIO input and use the ADC function select register in the SCU to select the ADC.
P7_5	A7	-	[6] I; PU	[6]	I/O <b>GPIO3[13]</b> — General purpose digital input/output pin.
					O <b>CTOUT_12</b> — SCT output 12. Match output 0 of timer 3.
					- <b>R</b> — Function reserved.
					O <b>LCD_VD8</b> — LCD data.
					O <b>LCD_VD23</b> — LCD data.
					O <b>TRACEDATA[1]</b> — Trace data, bit 1.
					- <b>R</b> — Function reserved.
					- <b>R</b> — Function reserved.
AI					<b>ADC0_3</b> — ADC0, input channel 3. Configure the pin as GPIO input and use the ADC function select register in the SCU to select the ADC.

**Table 3. Pin description ...continued**

LCD, Ethernet, USB0, and USB1 functions are not available on all parts. See [Table 2](#).

Symbol	LBGA256	TFBGA100	Reset state	Type	Description
P7_6	C7	-	[3]	I; PU	I/O <b>GPIO3[14]</b> — General purpose digital input/output pin.
					O <b>CTOUT_11</b> — SCT output 1. Match output 3 of timer 2.
					- <b>R</b> — Function reserved.
					O <b>LCD_LP</b> — Line synchronization pulse (STN). Horizontal synchronization pulse (TFT).
					- <b>R</b> — Function reserved.
					O <b>TRACEDATA[2]</b> — Trace data, bit 2.
					- <b>R</b> — Function reserved.
P7_7	B6	-	[6] [13]	I; PU	I/O <b>GPIO3[15]</b> — General purpose digital input/output pin.
					O <b>CTOUT_8</b> — SCT output 8. Match output 0 of timer 2.
					- <b>R</b> — Function reserved.
					O <b>LCD_PWR</b> — LCD panel power enable.
					- <b>R</b> — Function reserved.
					O <b>TRACEDATA[3]</b> — Trace data, bit 3.
					O <b>ENET_MDC</b> — Ethernet MIIM clock.
P8_0	E5	-	[4] [13]	I; PU	I/O <b>GPIO4[0]</b> — General purpose digital input/output pin.
					I <b>USB0_PWR_FAULT</b> — Port power fault signal indicating overcurrent condition; this signal monitors over-current on the USB bus (external circuitry required to detect over-current condition).
					- <b>R</b> — Function reserved.
					I <b>MC12</b> — Motor control PWM channel 2, input.
					I/O <b>SGPIO8</b> — General purpose digital input/output pin.
					- <b>R</b> — Function reserved.
					- <b>R</b> — Function reserved.
O <b>T0_MAT0</b> — Match output 0 of timer 0.					
P8_1	H5	-	[4]	I; PU	I/O <b>GPIO4[1]</b> — General purpose digital input/output pin.
					O <b>USB0_IND1</b> — USB0 port indicator LED control output 1.
					- <b>R</b> — Function reserved.
					I <b>MC11</b> — Motor control PWM channel 1, input.
					I/O <b>SGPIO9</b> — General purpose digital input/output pin.
					- <b>R</b> — Function reserved.
					- <b>R</b> — Function reserved.
O <b>T0_MAT1</b> — Match output 1 of timer 0.					

**Table 3. Pin description ...continued**LCD, Ethernet, USB0, and USB1 functions are not available on all parts. See [Table 2](#).

Symbol	LBGA256	TFBGA100	Reset state	Type	Description	
P8_2	K4	-	[4]	I; PU	I/O	<b>GPIO4[2]</b> — General purpose digital input/output pin.
					O	<b>USB0_IND0</b> — USB0 port indicator LED control output 0.
					-	<b>R</b> — Function reserved.
					I	<b>MCIO</b> — Motor control PWM channel 0, input.
					I/O	<b>SGPIO10</b> — General purpose digital input/output pin.
					-	<b>R</b> — Function reserved.
					-	<b>R</b> — Function reserved.
P8_3	J3	-	[3]	I; PU	I/O	<b>GPIO4[3]</b> — General purpose digital input/output pin.
					I/O	<b>USB1_ULPI_D2</b> — ULPI link bidirectional data line 2.
					-	<b>R</b> — Function reserved.
					O	<b>LCD_VD12</b> — LCD data.
					O	<b>LCD_VD19</b> — LCD data.
					-	<b>R</b> — Function reserved.
					-	<b>R</b> — Function reserved.
P8_4	J2	-	[3]	I; PU	I/O	<b>GPIO4[4]</b> — General purpose digital input/output pin.
					I/O	<b>USB1_ULPI_D1</b> — ULPI link bidirectional data line 1.
					-	<b>R</b> — Function reserved.
					O	<b>LCD_VD7</b> — LCD data.
					O	<b>LCD_VD16</b> — LCD data.
					-	<b>R</b> — Function reserved.
					-	<b>R</b> — Function reserved.
P8_5	J1	-	[3]	I; PU	I/O	<b>GPIO4[5]</b> — General purpose digital input/output pin.
					I/O	<b>USB1_ULPI_D0</b> — ULPI link bidirectional data line 0.
					-	<b>R</b> — Function reserved.
					O	<b>LCD_VD6</b> — LCD data.
					O	<b>LCD_VD8</b> — LCD data.
					-	<b>R</b> — Function reserved.
					-	<b>R</b> — Function reserved.
				I	<b>T0_CAP1</b> — Capture input 1 of timer 0.	

**Table 3. Pin description ...continued**

LCD, Ethernet, USB0, and USB1 functions are not available on all parts. See [Table 2](#).

Symbol	LPGA256	TFBGA100	Reset state	Type	Description	
P8_6	K3	-	[3]	I; PU	I/O	<b>GPIO4[6]</b> — General purpose digital input/output pin.
					I	<b>USB1_ULPI_NXT</b> — ULPI link NXT signal. Data flow control signal from the PHY.
					-	<b>R</b> — Function reserved.
					O	<b>LCD_VD5</b> — LCD data.
					O	<b>LCD_LP</b> — Line synchronization pulse (STN). Horizontal synchronization pulse (TFT).
					-	<b>R</b> — Function reserved.
					-	<b>R</b> — Function reserved.
					I	<b>T0_CAP2</b> — Capture input 2 of timer 0.
P8_7	K1	-	[3]	I; PU	I/O	<b>GPIO4[7]</b> — General purpose digital input/output pin.
					O	<b>USB1_ULPI_STP</b> — ULPI link STP signal. Asserted to end or interrupt transfers to the PHY.
					-	<b>R</b> — Function reserved.
					O	<b>LCD_VD4</b> — LCD data.
					O	<b>LCD_PWR</b> — LCD panel power enable.
					-	<b>R</b> — Function reserved.
					-	<b>R</b> — Function reserved.
					I	<b>T0_CAP3</b> — Capture input 3 of timer 0.
P8_8	L1	-	[3]	I; PU	-	<b>R</b> — Function reserved.
					I	<b>USB1_ULPI_CLK</b> — ULPI link CLK signal. 60 MHz clock generated by the PHY.
					-	<b>R</b> — Function reserved.
					-	<b>R</b> — Function reserved.
					-	<b>R</b> — Function reserved.
					-	<b>R</b> — Function reserved.
					O	<b>CGU_OUT0</b> — CGU spare clock output 0.
					O	<b>I2S1_TX_MCLK</b> — I2S1 transmit master clock.
P9_0	T1	-	[3]	I; PU	I/O	<b>GPIO4[12]</b> — General purpose digital input/output pin.
					O	<b>MCABORT</b> — Motor control PWM, LOW-active fast abort.
					-	<b>R</b> — Function reserved.
					-	<b>R</b> — Function reserved.
					-	<b>R</b> — Function reserved.
					I	<b>ENET_CRS</b> — Ethernet Carrier Sense (MII interface).
					I/O	<b>SGPIO0</b> — General purpose digital input/output pin.
					I/O	<b>SSP0_SSEL</b> — Slave Select for SSP0.

**Table 3. Pin description ...continued**LCD, Ethernet, USB0, and USB1 functions are not available on all parts. See [Table 2](#).

Symbol	LPGA256	TFBGA100	Reset state	Type	Description						
P9_1	N6	-	[3]	I; PU	I/O	<b>GPIO4[13]</b> — General purpose digital input/output pin.					
					O	<b>MCOA2</b> — Motor control PWM channel 2, output A.					
					-	<b>R</b> — Function reserved.					
					-	<b>R</b> — Function reserved.					
					I/O	<b>I2S0_TX_WS</b> — Transmit Word Select. It is driven by the master and received by the slave. Corresponds to the signal WS in the <i>I<sup>2</sup>S-bus specification</i> .					
					I	<b>ENET_RX_ER</b> — Ethernet receive error (MII interface).					
					I/O	<b>SGPIO1</b> — General purpose digital input/output pin.					
					I/O	<b>SSP0_MISO</b> — Master In Slave Out for SSP0.					
					P9_2	N8	-	[3]	I; PU	I/O	<b>GPIO4[14]</b> — General purpose digital input/output pin.
										O	<b>MCOB2</b> — Motor control PWM channel 2, output B.
-	<b>R</b> — Function reserved.										
-	<b>R</b> — Function reserved.										
I/O	<b>I2S0_TX_SDA</b> — I2S transmit data. It is driven by the transmitter and read by the receiver. Corresponds to the signal SD in the <i>I<sup>2</sup>S-bus specification</i> .										
I	<b>ENET_RXD3</b> — Ethernet receive data 3 (MII interface).										
I/O	<b>SGPIO2</b> — General purpose digital input/output pin.										
I/O	<b>SSP0_MOSI</b> — Master Out Slave in for SSP0.										
P9_3	M6	-	[3]	I; PU						I/O	<b>GPIO4[15]</b> — General purpose digital input/output pin.
										O	<b>MCOA0</b> — Motor control PWM channel 0, output A.
					O	<b>USB1_IND1</b> — USB1 Port indicator LED control output 1.					
					-	<b>R</b> — Function reserved.					
					-	<b>R</b> — Function reserved.					
					I	<b>ENET_RXD2</b> — Ethernet receive data 2 (MII interface).					
					I/O	<b>SGPIO9</b> — General purpose digital input/output pin.					
					O	<b>U3_TXD</b> — Transmitter output for USART3.					
					P9_4	N10	-	[3]	I; PU	-	<b>R</b> — Function reserved.
										O	<b>MCOB0</b> — Motor control PWM channel 0, output B.
O	<b>USB1_IND0</b> — USB1 Port indicator LED control output 0.										
-	<b>R</b> — Function reserved.										
I/O	<b>GPIO5[17]</b> — General purpose digital input/output pin.										
O	<b>ENET_TXD2</b> — Ethernet transmit data 2 (MII interface).										
I/O	<b>SGPIO4</b> — General purpose digital input/output pin.										
I	<b>U3_RXD</b> — Receiver input for USART3.										

**Table 3. Pin description ...continued**

LCD, Ethernet, USB0, and USB1 functions are not available on all parts. See [Table 2](#).

Symbol	LBGA256	TFBGA100	Reset state	Type	Description
P9_5	M9	-	[3]	I; PU	- R — Function reserved.
					O <b>MCOA1</b> — Motor control PWM channel 1, output A.
					O <b>USB1_VBUS_EN</b> — USB1 VBUS power enable.
					- R — Function reserved.
					I/O <b>GPIO5[18]</b> — General purpose digital input/output pin.
					O <b>ENET_TXD3</b> — Ethernet transmit data 3 (MII interface).
					I/O <b>SGPIO3</b> — General purpose digital input/output pin.
					O <b>U0_TXD</b> — Transmitter output for USART0.
P9_6	L11	-	[3]	I; PU	I/O <b>GPIO4[11]</b> — General purpose digital input/output pin.
					O <b>MCOB1</b> — Motor control PWM channel 1, output B.
					I <b>USB1_PWR_FAULT</b> — USB1 Port power fault signal indicating over-current condition; this signal monitors over-current on the USB1 bus (external circuitry required to detect over-current condition).
					- R — Function reserved.
					- R — Function reserved.
					I <b>ENET_COL</b> — Ethernet Collision detect (MII interface).
					I/O <b>SGPIO8</b> — General purpose digital input/output pin.
					I <b>U0_RXD</b> — Receiver input for USART0.
PA_0	L12	-	[3]	I; PU	- R — Function reserved.
					- R — Function reserved.
					- R — Function reserved.
					- R — Function reserved.
					- R — Function reserved.
					- R — Function reserved.
					O <b>I2S1_RX_MCLK</b> — I2S1 receive master clock.
					O <b>CGU_OUT1</b> — CGU spare clock output 1.
- R — Function reserved.					
PA_1	J14	-	[4]	I; PU	I/O <b>GPIO4[8]</b> — General purpose digital input/output pin.
					I <b>QEI_IDX</b> — Quadrature Encoder Interface INDEX input.
					- R — Function reserved.
					O <b>U2_TXD</b> — Transmitter output for USART2.
					- R — Function reserved.
					- R — Function reserved.
					- R — Function reserved.
					- R — Function reserved.

**Table 3. Pin description ...continued**LCD, Ethernet, USB0, and USB1 functions are not available on all parts. See [Table 2](#).

Symbol	LBGA256	TFBGA100	Reset state	Type	Description	
PA_2	K15	-	[4]	I; PU	I/O	<b>GPIO4[9]</b> — General purpose digital input/output pin.
					I	<b>QEI_PHB</b> — Quadrature Encoder Interface PHB input.
					-	<b>R</b> — Function reserved.
					I	<b>U2_RXD</b> — Receiver input for USART2.
					-	<b>R</b> — Function reserved.
					-	<b>R</b> — Function reserved.
					-	<b>R</b> — Function reserved.
PA_3	H11	-	[4]	I; PU	I/O	<b>GPIO4[10]</b> — General purpose digital input/output pin.
					I	<b>QEI_PHA</b> — Quadrature Encoder Interface PHA input.
					-	<b>R</b> — Function reserved.
					-	<b>R</b> — Function reserved.
					-	<b>R</b> — Function reserved.
					-	<b>R</b> — Function reserved.
					-	<b>R</b> — Function reserved.
PA_4	G13	-	[3]	I; PU	-	<b>R</b> — Function reserved.
					O	<b>CTOUT_9</b> — SCT output 9. Match output 1 of timer 2.
					-	<b>R</b> — Function reserved.
					I/O	<b>EMC_A23</b> — External memory address line 23.
					I/O	<b>GPIO5[19]</b> — General purpose digital input/output pin.
					-	<b>R</b> — Function reserved.
					-	<b>R</b> — Function reserved.
PB_0	B15	-	[3]	I; PU	-	<b>R</b> — Function reserved.
					O	<b>CTOUT_10</b> — SCT output 10. Match output 2 of timer 2.
					O	<b>LCD_VD23</b> — LCD data.
					-	<b>R</b> — Function reserved.
					I/O	<b>GPIO5[20]</b> — General purpose digital input/output pin.
					-	<b>R</b> — Function reserved.
					-	<b>R</b> — Function reserved.
-	<b>R</b> — Function reserved.					

**Table 3. Pin description ...continued**

LCD, Ethernet, USB0, and USB1 functions are not available on all parts. See [Table 2](#).

Symbol	LBGA256	TFBGA100	Reset state	Type	Description
PB_1	A14	-	③	I; PU	- R — Function reserved.
					I <b>USB1_ULPI_DIR</b> — ULPI link DIR signal. Controls the ULP data line direction.
					O <b>LCD_VD22</b> — LCD data.
					- R — Function reserved.
					I/O <b>GPIO5[21]</b> — General purpose digital input/output pin.
					O <b>CTOUT_6</b> — SCT output 6. Match output 2 of timer 1.
					- R — Function reserved.
					- R — Function reserved.
PB_2	B12	-	③	I; PU	- R — Function reserved.
					I/O <b>USB1_ULPI_D7</b> — ULPI link bidirectional data line 7.
					O <b>LCD_VD21</b> — LCD data.
					- R — Function reserved.
					I/O <b>GPIO5[22]</b> — General purpose digital input/output pin.
					O <b>CTOUT_7</b> — SCT output 7. Match output 3 of timer 1.
					- R — Function reserved.
					- R — Function reserved.
PB_3	A13	-	③	I; PU	- R — Function reserved.
					I/O <b>USB1_ULPI_D6</b> — ULPI link bidirectional data line 6.
					O <b>LCD_VD20</b> — LCD data.
					- R — Function reserved.
					I/O <b>GPIO5[23]</b> — General purpose digital input/output pin.
					O <b>CTOUT_8</b> — SCT output 8. Match output 0 of timer 2.
					- R — Function reserved.
					- R — Function reserved.
PB_4	B11	-	③	I; PU	- R — Function reserved.
					I/O <b>USB1_ULPI_D5</b> — ULPI link bidirectional data line 5.
					O <b>LCD_VD15</b> — LCD data.
					- R — Function reserved.
					I/O <b>GPIO5[24]</b> — General purpose digital input/output pin.
					I <b>CTIN_5</b> — SCT input 5. Capture input 2 of timer 2.
					- R — Function reserved.
					- R — Function reserved.

**Table 3. Pin description ...continued**LCD, Ethernet, USB0, and USB1 functions are not available on all parts. See [Table 2](#).

Symbol	LBGA256	TFBGA100	Reset state	Type	Description
PB_5	A12	-	<a href="#">[3]</a>	I; PU	- R — Function reserved.
					I/O <b>USB1_ULPI_D4</b> — ULPI link bidirectional data line 4.
					O <b>LCD_VD14</b> — LCD data.
					- R — Function reserved.
					I/O <b>GPIO5[25]</b> — General purpose digital input/output pin.
					I <b>CTIN_7</b> — SCT input 7.
					O <b>LCD_PWR</b> — LCD panel power enable.
PB_6	A6	-	<a href="#">[6]</a> <a href="#">[13]</a>	I; PU	- R — Function reserved.
					I/O <b>USB1_ULPI_D3</b> — ULPI link bidirectional data line 3.
					O <b>LCD_VD13</b> — LCD data.
					- R — Function reserved.
					I/O <b>GPIO5[26]</b> — General purpose digital input/output pin.
					I <b>CTIN_6</b> — SCT input 6. Capture input 1 of timer 3.
					O <b>LCD_VD19</b> — LCD data.
PC_0	D4	-	<a href="#">[6]</a> <a href="#">[13]</a>	I; PU	- R — Function reserved.
					I <b>USB1_ULPI_CLK</b> — ULPI link CLK signal. 60 MHz clock generated by the PHY.
					- R — Function reserved.
					I/O <b>ENET_RX_CLK</b> — Ethernet Receive Clock (MIIM interface).
					O <b>LCD_DCLK</b> — LCD panel clock.
					- R — Function reserved.
					- R — Function reserved.
I/O <b>SD_CLK</b> — SD/MMC card clock.					
PC_1	E4	-	<a href="#">[3]</a>	I; PU	I/O <b>USB1_ULPI_D7</b> — ULPI link bidirectional data line 7.
					- R — Function reserved.
					I <b>U1_RI</b> — Ring Indicator input for UART 1.
					O <b>ENET_MDC</b> — Ethernet MIIM clock.
					I/O <b>GPIO6[0]</b> — General purpose digital input/output pin.
					- R — Function reserved.
					I <b>T3_CAP0</b> — Capture input 0 of timer 3.
O <b>SD_VOLT0</b> — SD/MMC bus voltage select output 0.					

**Table 3. Pin description ...continued**

LCD, Ethernet, USB0, and USB1 functions are not available on all parts. See [Table 2](#).

Symbol	LBGA256	TFBGA100	Reset state	Type	Description
PC_2	F6	-	[3] I; PU	I/O	<b>USB1_ULPI_D6</b> — ULPI link bidirectional data line 6.
					- R — Function reserved.
					I <b>U1_CTS</b> — Clear to Send input for UART 1.
					O <b>ENET_TXD2</b> — Ethernet transmit data 2 (MII interface).
					I/O <b>GPIO6[1]</b> — General purpose digital input/output pin.
					- R — Function reserved.
					- R — Function reserved.
PC_3	F5	-	[6] I; PU	I/O	<b>USB1_ULPI_D5</b> — ULPI link bidirectional data line 5.
					- R — Function reserved.
					O <b>U1_RTS</b> — Request to Send output for UART 1. Can also be configured to be an RS-485/EIA-485 output enable signal for UART 1.
					O <b>ENET_TXD3</b> — Ethernet transmit data 3 (MII interface).
					I/O <b>GPIO6[2]</b> — General purpose digital input/output pin.
					- R — Function reserved.
					- R — Function reserved.
PC_4	F4	-	[3] I; PU	-	R — Function reserved.
					I/O <b>USB1_ULPI_D4</b> — ULPI link bidirectional data line 4.
					- R — Function reserved.
					<b>ENET_TX_EN</b> — Ethernet transmit enable (RMII/MII interface).
					I/O <b>GPIO6[3]</b> — General purpose digital input/output pin.
					- R — Function reserved.
					I <b>T3_CAP1</b> — Capture input 1 of timer 3.
PC_5	G4	-	[3] I; PU	-	R — Function reserved.
					I/O <b>USB1_ULPI_D3</b> — ULPI link bidirectional data line 3.
					- R — Function reserved.
					O <b>ENET_TX_ER</b> — Ethernet Transmit Error (MII interface).
					I/O <b>GPIO6[4]</b> — General purpose digital input/output pin.
					- R — Function reserved.
					I <b>T3_CAP2</b> — Capture input 2 of timer 3.
I/O <b>SD_DAT1</b> — SD/MMC data bus line 1.					

**Table 3. Pin description ...continued**LCD, Ethernet, USB0, and USB1 functions are not available on all parts. See [Table 2](#).

Symbol	LBGA256	TFBGA100	Reset state	Type	Description
PC_6	H6	-	③	I; PU	- R — Function reserved.
					I/O <b>USB1_ULPI_D2</b> — ULPI link bidirectional data line 2.
					- R — Function reserved.
					I <b>ENET_RXD2</b> — Ethernet receive data 2 (MII interface).
					I/O <b>GPIO6[5]</b> — General purpose digital input/output pin.
					- R — Function reserved.
					I <b>T3_CAP3</b> — Capture input 3 of timer 3.
PC_7	G5	-	③	I; PU	- R — Function reserved.
					I/O <b>USB1_ULPI_D1</b> — ULPI link bidirectional data line 1.
					- R — Function reserved.
					I <b>ENET_RXD3</b> — Ethernet receive data 3 (MII interface).
					I/O <b>GPIO6[6]</b> — General purpose digital input/output pin.
					- R — Function reserved.
					O <b>T3_MAT0</b> — Match output 0 of timer 3.
PC_8	N4	-	③	I; PU	- R — Function reserved.
					I/O <b>USB1_ULPI_D0</b> — ULPI link bidirectional data line 0.
					- R — Function reserved.
					I <b>ENET_RX_DV</b> — Ethernet Receive Data Valid (RMII/MII interface).
					I/O <b>GPIO6[7]</b> — General purpose digital input/output pin.
					- R — Function reserved.
					O <b>T3_MAT1</b> — Match output 1 of timer 3.
PC_9	K2	-	③	I; PU	- R — Function reserved.
					I <b>USB1_ULPI_NXT</b> — ULPI link NXT signal. Data flow control signal from the PHY.
					- R — Function reserved.
					I <b>ENET_RX_ER</b> — Ethernet receive error (MII interface).
					I/O <b>GPIO6[8]</b> — General purpose digital input/output pin.
					- R — Function reserved.
					O <b>T3_MAT2</b> — Match output 2 of timer 3.
O <b>SD_POW</b> — SD/MMC power monitor output.					

**Table 3. Pin description ...continued**LCD, Ethernet, USB0, and USB1 functions are not available on all parts. See [Table 2](#).

Symbol	LPGA256	TFBGA100	Reset state	Type	Description
PC_10	M5	-	[3] I; PU	-	R — Function reserved.
				O	<b>USB1_ULPI_STP</b> — ULPI link STP signal. Asserted to end or interrupt transfers to the PHY.
				I	<b>U1_DSR</b> — Data Set Ready input for UART 1.
				-	R — Function reserved.
				I/O	<b>GPIO6[9]</b> — General purpose digital input/output pin.
				-	R — Function reserved.
				O	<b>T3_MAT3</b> — Match output 3 of timer 3.
				I/O	<b>SD_CMD</b> — SD/MMC command signal.
PC_11	L5	-	[3] I; PU	-	R — Function reserved.
				I	<b>USB1_ULPI_DIR</b> — ULPI link DIR signal. Controls the ULPI data line direction.
				I	<b>U1_DCD</b> — Data Carrier Detect input for UART 1.
				-	R — Function reserved.
				I/O	<b>GPIO6[10]</b> — General purpose digital input/output pin.
				-	R — Function reserved.
				-	R — Function reserved.
				I/O	<b>SD_DAT4</b> — SD/MMC data bus line 4.
PC_12	L6	-	[3] I; PU	-	R — Function reserved.
				-	R — Function reserved.
				O	<b>U1_DTR</b> — Data Terminal Ready output for UART 1. Can also be configured to be an RS-485/EIA-485 output enable signal for UART 1.
				-	R — Function reserved.
				I/O	<b>GPIO6[11]</b> — General purpose digital input/output pin.
				I/O	<b>SGPIO11</b> — General purpose digital input/output pin.
				I/O	<b>I2S0_TX_SDA</b> — I2S transmit data. It is driven by the transmitter and read by the receiver. Corresponds to the signal SD in the <i>I<sup>2</sup>S-bus specification</i> .
				I/O	<b>SD_DAT5</b> — SD/MMC data bus line 5.
PC_13	M1	-	[3] I; PU	-	R — Function reserved.
				-	R — Function reserved.
				O	<b>U1_TXD</b> — Transmitter output for UART 1.
				-	R — Function reserved.
				I/O	<b>GPIO6[12]</b> — General purpose digital input/output pin.
				I/O	<b>SGPIO12</b> — General purpose digital input/output pin.
				I/O	<b>I2S0_TX_WS</b> — Transmit Word Select. It is driven by the master and received by the slave. Corresponds to the signal WS in the <i>I<sup>2</sup>S-bus specification</i> .
				I/O	<b>SD_DAT6</b> — SD/MMC data bus line 6.

**Table 3. Pin description ...continued**LCD, Ethernet, USB0, and USB1 functions are not available on all parts. See [Table 2](#).

Symbol	LBGA256	TFBGA100	Reset state	Type	Description
PC_14	N1	-	③	I; PU	- R — Function reserved.
					- R — Function reserved.
					I U1_RXD — Receiver input for UART 1.
					- R — Function reserved.
					I/O GPIO6[13] — General purpose digital input/output pin.
					I/O SGPIO13 — General purpose digital input/output pin.
					O ENET_TX_ER — Ethernet Transmit Error (MII interface).
					I/O SD_DAT7 — SD/MMC data bus line 7.
PD_0	N2	-	③	I; PU	- R — Function reserved.
					O CTOUT_15 — SCT output 15. Match output 3 of timer 3.
					O EMC_DQMOUT2 — Data mask 2 used with SDRAM and static devices.
					- R — Function reserved.
					I/O GPIO6[14] — General purpose digital input/output pin.
					- R — Function reserved.
					- R — Function reserved.
					I/O SGPIO4 — General purpose digital input/output pin.
PD_1	P1	-	③	I; PU	- R — Function reserved.
					- R — Function reserved.
					O EMC_CKEOUT2 — SDRAM clock enable 2.
					- R — Function reserved.
					I/O GPIO6[15] — General purpose digital input/output pin.
					O SD_POW — SD/MMC power monitor output.
					- R — Function reserved.
					I/O SGPIO5 — General purpose digital input/output pin.
PD_2	R1	-	③	I; PU	- R — Function reserved.
					O CTOUT_7 — SCT output 7. Match output 3 of timer 1.
					I/O EMC_D16 — External memory data line 16.
					- R — Function reserved.
					I/O GPIO6[16] — General purpose digital input/output pin.
					- R — Function reserved.
					- R — Function reserved.
					I/O SGPIO6 — General purpose digital input/output pin.

**Table 3. Pin description ...continued**LCD, Ethernet, USB0, and USB1 functions are not available on all parts. See [Table 2](#).

Symbol	LBGA256	TFBGA100	Reset state	Type	Description
PD_3	P4	-	③	I; PU	- R — Function reserved.
					O <b>CTOUT_6</b> — SCT output 7. Match output 2 of timer 1.
					I/O <b>EMC_D17</b> — External memory data line 17.
					- R — Function reserved.
					I/O <b>GPIO6[17]</b> — General purpose digital input/output pin.
					- R — Function reserved.
					- R — Function reserved.
PD_4	T2	-	③	I; PU	- R — Function reserved.
					O <b>CTOUT_8</b> — SCT output 8. Match output 0 of timer 2.
					I/O <b>EMC_D18</b> — External memory data line 18.
					- R — Function reserved.
					I/O <b>GPIO6[18]</b> — General purpose digital input/output pin.
					- R — Function reserved.
					- R — Function reserved.
PD_5	P6	-	③	I; PU	- R — Function reserved.
					O <b>CTOUT_9</b> — SCT output 9. Match output 1 of timer 2.
					I/O <b>EMC_D19</b> — External memory data line 19.
					- R — Function reserved.
					I/O <b>GPIO6[19]</b> — General purpose digital input/output pin.
					- R — Function reserved.
					- R — Function reserved.
PD_6	R6	-	③	I; PU	- R — Function reserved.
					O <b>CTOUT_10</b> — SCT output 10. Match output 2 of timer 2.
					I/O <b>EMC_D20</b> — External memory data line 20.
					- R — Function reserved.
					I/O <b>GPIO6[20]</b> — General purpose digital input/output pin.
					- R — Function reserved.
					- R — Function reserved.
					I/O <b>SGPIO10</b> — General purpose digital input/output pin.

**Table 3. Pin description ...continued**LCD, Ethernet, USB0, and USB1 functions are not available on all parts. See [Table 2](#).

Symbol	LBGA256	TFBGA100	Reset state	Type	Description
PD_7	T6	-	③	I; PU	- R — Function reserved.
					I <b>CTIN_5</b> — SCT input 5. Capture input 2 of timer 2.
					I/O <b>EMC_D21</b> — External memory data line 21.
					- R — Function reserved.
					I/O <b>GPIO6[21]</b> — General purpose digital input/output pin.
					- R — Function reserved.
					- R — Function reserved.
PD_8	P8	-	③	I; PU	- R — Function reserved.
					I <b>CTIN_6</b> — SCT input 6. Capture input 1 of timer 3.
					I/O <b>EMC_D22</b> — External memory data line 22.
					- R — Function reserved.
					I/O <b>GPIO6[22]</b> — General purpose digital input/output pin.
					- R — Function reserved.
					- R — Function reserved.
PD_9	T11	-	③	I; PU	- R — Function reserved.
					O <b>CTOUT_13</b> — SCT output 13. Match output 1 of timer 3.
					I/O <b>EMC_D23</b> — External memory data line 23.
					- R — Function reserved.
					I/O <b>GPIO6[23]</b> — General purpose digital input/output pin.
					- R — Function reserved.
					- R — Function reserved.
PD_10	P11	-	③	I; PU	- R — Function reserved.
					I <b>CTIN_1</b> — SCT input 1. Capture input 1 of timer 0. Capture input 1 of timer 2.
					O <b>EMC_BLS3</b> — LOW active Byte Lane select signal 3.
					- R — Function reserved.
					I/O <b>GPIO6[24]</b> — General purpose digital input/output pin.
					- R — Function reserved.
					- R — Function reserved.
- R — Function reserved.					

**Table 3. Pin description ...continued**LCD, Ethernet, USB0, and USB1 functions are not available on all parts. See [Table 2](#).

Symbol	LBGA256	TFBGA100	Reset state	Type	Description
PD_11	N9	-	③	I; PU	- R — Function reserved.
					- R — Function reserved.
					O <b>EMC_CS3</b> — LOW active Chip Select 3 signal.
					- R — Function reserved.
					I/O <b>GPIO6[25]</b> — General purpose digital input/output pin.
					I/O <b>USB1_ULPI_D0</b> — ULPI link bidirectional data line 0.
					O <b>CTOUT_14</b> — SCT output 14. Match output 2 of timer 3.
PD_12	N11	-	③	I; PU	- R — Function reserved.
					- R — Function reserved.
					O <b>EMC_CS2</b> — LOW active Chip Select 2 signal.
					- R — Function reserved.
					I/O <b>GPIO6[26]</b> — General purpose digital input/output pin.
					O <b>CTOUT_10</b> — SCT output 10. Match output 2 of timer 2.
					- R — Function reserved.
PD_13	T14	-	③	I; PU	- R — Function reserved.
					I <b>CTIN_0</b> — SCT input 0. Capture input 0 of timer 0, 1, 2, 3.
					O <b>EMC_BLS2</b> — LOW active Byte Lane select signal 2.
					- R — Function reserved.
					I/O <b>GPIO6[27]</b> — General purpose digital input/output pin.
					O <b>CTOUT_13</b> — SCT output 13. Match output 1 of timer 3.
					- R — Function reserved.
PD_14	R13	-	③	I; PU	- R — Function reserved.
					- R — Function reserved.
					O <b>EMC_DYCS2</b> — SDRAM chip select 2.
					- R — Function reserved.
					I/O <b>GPIO6[28]</b> — General purpose digital input/output pin.
					O <b>CTOUT_11</b> — SCT output 11. Match output 3 of timer 2.
					- R — Function reserved.

**Table 3. Pin description ...continued**LCD, Ethernet, USB0, and USB1 functions are not available on all parts. See [Table 2](#).

Symbol	LBGA256	TFBGA100	Reset state	Type	Description
PD_15	T15	-	③	I; PU	- R — Function reserved.
					- R — Function reserved.
					I/O <b>EMC_A17</b> — External memory address line 17.
					- R — Function reserved.
					I/O <b>GPIO6[29]</b> — General purpose digital input/output pin.
					I <b>SD_WP</b> — SD/MMC card write protect input.
					O <b>CTOUT_8</b> — SCT output 8. Match output 0 of timer 2.
PD_16	R14	-	③	I; PU	- R — Function reserved.
					- R — Function reserved.
					I/O <b>EMC_A16</b> — External memory address line 16.
					- R — Function reserved.
					I/O <b>GPIO6[30]</b> — General purpose digital input/output pin.
					O <b>SD_VOLT2</b> — SD/MMC bus voltage select output 2.
					O <b>CTOUT_12</b> — SCT output 12. Match output 0 of timer 3.
PE_0	P14	-	③	I; PU	- R — Function reserved.
					- R — Function reserved.
					- R — Function reserved.
					I/O <b>EMC_A18</b> — External memory address line 18.
					I/O <b>GPIO7[0]</b> — General purpose digital input/output pin.
					O <b>CAN1_TD</b> — CAN1 transmitter output.
					- R — Function reserved.
PE_1	N14	-	③	I; PU	- R — Function reserved.
					- R — Function reserved.
					- R — Function reserved.
					I/O <b>EMC_A19</b> — External memory address line 19.
					I/O <b>GPIO7[1]</b> — General purpose digital input/output pin.
					I <b>CAN1_RD</b> — CAN1 receiver input.
					- R — Function reserved.
- R — Function reserved.					

**Table 3. Pin description ...continued**LCD, Ethernet, USB0, and USB1 functions are not available on all parts. See [Table 2](#).

Symbol	LBGA256	TFBGA100	Reset state	Type	Description
PE_2	M14	-	③	I; PU	I <b>ADCTRIG0</b> — ADC trigger input 0.
					I <b>CAN0_RD</b> — CAN receiver input.
					- <b>R</b> — Function reserved.
					I/O <b>EMC_A20</b> — External memory address line 20.
					I/O <b>GPIO7[2]</b> — General purpose digital input/output pin.
					- <b>R</b> — Function reserved.
					- <b>R</b> — Function reserved.
PE_3	K12	-	③	I; PU	- <b>R</b> — Function reserved.
					O <b>CAN0_TD</b> — CAN transmitter output.
					I <b>ADCTRIG1</b> — ADC trigger input 1.
					I/O <b>EMC_A21</b> — External memory address line 21.
					I/O <b>GPIO7[3]</b> — General purpose digital input/output pin.
					- <b>R</b> — Function reserved.
					- <b>R</b> — Function reserved.
PE_4	K13	-	③	I; PU	- <b>R</b> — Function reserved.
					I <b>NMI</b> — External interrupt input to NMI.
					- <b>R</b> — Function reserved.
					I/O <b>EMC_A22</b> — External memory address line 22.
					I/O <b>GPIO7[4]</b> — General purpose digital input/output pin.
					- <b>R</b> — Function reserved.
					- <b>R</b> — Function reserved.
PE_5	N16	-	③	I; PU	- <b>R</b> — Function reserved.
					O <b>CTOUT_3</b> — SCT output 3. Match output 3 of timer 0.
					O <b>U1_RTS</b> — Request to Send output for UART 1. Can also be configured to be an RS-485/EIA-485 output enable signal for UART 1.
					I/O <b>EMC_D24</b> — External memory data line 24.
					I/O <b>GPIO7[5]</b> — General purpose digital input/output pin.
					- <b>R</b> — Function reserved.
					- <b>R</b> — Function reserved.
- <b>R</b> — Function reserved.					

**Table 3. Pin description ...continued**LCD, Ethernet, USB0, and USB1 functions are not available on all parts. See [Table 2](#).

Symbol	LBGA256	TFBGA100	Reset state	Type	Description
PE_6	M16	-	③	I; PU	- R — Function reserved.
					O <b>CTOUT_2</b> — SCT output 2. Match output 2 of timer 0.
					I <b>U1_RI</b> — Ring Indicator input for UART 1.
					I/O <b>EMC_D25</b> — External memory data line 25.
					I/O <b>GPIO7[6]</b> — General purpose digital input/output pin.
					- R — Function reserved.
					- R — Function reserved.
PE_7	F15	-	③	I; PU	- R — Function reserved.
					O <b>CTOUT_5</b> — SCT output 5. Match output 1 of timer 1.
					I <b>U1_CTS</b> — Clear to Send input for UART1.
					I/O <b>EMC_D26</b> — External memory data line 26.
					I/O <b>GPIO7[7]</b> — General purpose digital input/output pin.
					- R — Function reserved.
					- R — Function reserved.
PE_8	F14	-	③	I; PU	- R — Function reserved.
					O <b>CTOUT_4</b> — SCT output 4. Match output 0 of timer 0.
					I <b>U1_DSR</b> — Data Set Ready input for UART 1.
					I/O <b>EMC_D27</b> — External memory data line 27.
					I/O <b>GPIO7[8]</b> — General purpose digital input/output pin.
					- R — Function reserved.
					- R — Function reserved.
PE_9	E16	-	③	I; PU	- R — Function reserved.
					I <b>CTIN_4</b> — SCT input 4. Capture input 2 of timer 1.
					I <b>U1_DCD</b> — Data Carrier Detect input for UART 1.
					I/O <b>EMC_D28</b> — External memory data line 28.
					I/O <b>GPIO7[9]</b> — General purpose digital input/output pin.
					- R — Function reserved.
					- R — Function reserved.
- R — Function reserved.					

**Table 3. Pin description ...continued**

LCD, Ethernet, USB0, and USB1 functions are not available on all parts. See [Table 2](#).

Symbol	LBGA256	TFBGA100	Reset state	Type	Description
PE_10	E14	-	[3]	I; PU	- R — Function reserved.
					I <b>CTIN_3</b> — SCT input 3. Capture input 1 of timer 1.
					O <b>U1_DTR</b> — Data Terminal Ready output for UART 1. Can also be configured to be an RS-485/EIA-485 output enable signal for UART 1.
					I/O <b>EMC_D29</b> — External memory data line 29.
					I/O <b>GPIO7[10]</b> — General purpose digital input/output pin.
					- R — Function reserved.
					- R — Function reserved.
PE_11	D16	-	[3]	I; PU	- R — Function reserved.
					O <b>CTOUT_12</b> — SCT output 12. Match output 0 of timer 3.
					O <b>U1_TXD</b> — Transmitter output for UART 1.
					I/O <b>EMC_D30</b> — External memory data line 30.
					I/O <b>GPIO7[11]</b> — General purpose digital input/output pin.
					- R — Function reserved.
					- R — Function reserved.
PE_12	D15	-	[3]	I; PU	- R — Function reserved.
					O <b>CTOUT_11</b> — SCT output 11. Match output 3 of timer 2.
					I <b>U1_RXD</b> — Receiver input for UART 1.
					I/O <b>EMC_D31</b> — External memory data line 31.
					I/O <b>GPIO7[12]</b> — General purpose digital input/output pin.
					- R — Function reserved.
					- R — Function reserved.
PE_13	G14	-	[3]	I; PU	- R — Function reserved.
					O <b>CTOUT_14</b> — SCT output 14. Match output 2 of timer 3.
					I/O <b>I2C1_SDA</b> — I <sup>2</sup> C1 data input/output (this pin does not use a specialized I <sup>2</sup> C pad).
					O <b>EMC_DQMOUT3</b> — Data mask 3 used with SDRAM and static devices.
					I/O <b>GPIO7[13]</b> — General purpose digital input/output pin.
					- R — Function reserved.
					- R — Function reserved.

**Table 3. Pin description ...continued**LCD, Ethernet, USB0, and USB1 functions are not available on all parts. See [Table 2](#).

Symbol	LBGA256	TFBGA100	Reset state	Type	Description
PE_14	C15	-	I; PU	-	R — Function reserved.
					R — Function reserved.
					R — Function reserved.
					O <b>EMC_DYCS3</b> — SDRAM chip select 3.
					I/O <b>GPIO7[14]</b> — General purpose digital input/output pin.
					R — Function reserved.
					R — Function reserved.
PE_15	E13	-	I; PU	-	R — Function reserved.
					O <b>CTOUT_0</b> — SCT output 0. Match output 0 of timer 0.
					I/O <b>I2C1_SCL</b> — I <sup>2</sup> C1 clock input/output (this pin does not use a specialized I <sup>2</sup> C pad).
					O <b>EMC_CKEOUT3</b> — SDRAM clock enable 3.
					I/O <b>GPIO7[15]</b> — General purpose digital input/output pin.
					R — Function reserved.
					R — Function reserved.
PF_0	D12	-	O; PU	-	I/O <b>SSP0_SCK</b> — Serial clock for SSP0.
					I <b>GP_CLKIN</b> — General purpose clock input to the CGU.
					R — Function reserved.
					R — Function reserved.
					R — Function reserved.
					R — Function reserved.
					R — Function reserved.
PF_1	E11	-	I; PU	-	R — Function reserved.
					R — Function reserved.
					I/O <b>SSP0_SSEL</b> — Slave Select for SSP0.
					R — Function reserved.
					I/O <b>GPIO7[16]</b> — General purpose digital input/output pin.
					R — Function reserved.
					I/O <b>SGPIO0</b> — General purpose digital input/output pin.
R — Function reserved.					

**Table 3. Pin description ...continued**LCD, Ethernet, USB0, and USB1 functions are not available on all parts. See [Table 2](#).

Symbol	LBGA256	TFBGA100	Reset state	Type	Description
PF_2	D11	-	③	I; PU	- R — Function reserved.
					O <b>U3_TXD</b> — Transmitter output for USART3.
					I/O <b>SSP0_MISO</b> — Master In Slave Out for SSP0.
					- R — Function reserved.
					I/O <b>GPIO7[17]</b> — General purpose digital input/output pin.
					- R — Function reserved.
					I/O <b>SGPIO1</b> — General purpose digital input/output pin.
PF_3	E10	-	③	I; PU	- R — Function reserved.
					I <b>U3_RXD</b> — Receiver input for USART3.
					I/O <b>SSP0_MOSI</b> — Master Out Slave in for SSP0.
					- R — Function reserved.
					I/O <b>GPIO7[18]</b> — General purpose digital input/output pin.
					- R — Function reserved.
					I/O <b>SGPIO2</b> — General purpose digital input/output pin.
PF_4	D10	H4	③	O; PU	I/O <b>SSP1_SCK</b> — Serial clock for SSP1.
					I <b>GP_CLKIN</b> — General purpose clock input to the CGU.
					O <b>TRACECLK</b> — Trace clock.
					- R — Function reserved.
					- R — Function reserved.
					- R — Function reserved.
					O <b>I2S0_TX_MCLK</b> — I2S transmit master clock.
I/O <b>I2S0_RX_SCK</b> — I2S receive clock. It is driven by the master and received by the slave. Corresponds to the signal SCK in the <i>I<sup>2</sup>S-bus specification</i> .					
PF_5	E9	-	⑥	I; PU	- R — Function reserved.
					I/O <b>U3_UCLK</b> — Serial clock input/output for USART3 in synchronous mode.
					I/O <b>SSP1_SSEL</b> — Slave Select for SSP1.
					O <b>TRACEDATA[0]</b> — Trace data, bit 0.
					I/O <b>GPIO7[19]</b> — General purpose digital input/output pin.
					- R — Function reserved.
					I/O <b>SGPIO4</b> — General purpose digital input/output pin.
					- R — Function reserved.
					AI <b>ADC1_4</b> — ADC1, input channel 4. Configure the pin as GPIO input and use the ADC function select register in the SCU to select the ADC.

**Table 3. Pin description ...continued**

LCD, Ethernet, USB0, and USB1 functions are not available on all parts. See [Table 2](#).

Symbol	LBGA256	TFBGA100	Reset state	Type	Description
PF_6	E7	-	[6] I; PU	[2] -	R — Function reserved.
					I/O <b>U3_DIR</b> — RS-485/EIA-485 output enable/direction control for USART3.
					I/O <b>SSP1_MISO</b> — Master In Slave Out for SSP1.
					O <b>TRACEDATA[1]</b> — Trace data, bit 1.
					I/O <b>GPIO7[20]</b> — General purpose digital input/output pin.
					- R — Function reserved.
					I/O <b>SGPIO5</b> — General purpose digital input/output pin.
					I/O <b>I2S1_TX_SDA</b> — I2S1 transmit data. It is driven by the transmitter and read by the receiver. Corresponds to the signal SD in the <i>I<sup>2</sup>S-bus specification</i> .
					AI <b>ADC1_3</b> — ADC1, input channel 3. Configure the pin as GPIO input and use the ADC function select register in the SCU to select the ADC.
PF_7	B7	-	[6] I; PU	-	R — Function reserved.
					I/O <b>U3_BAUD</b> — Baud pin for USART3.
					I/O <b>SSP1_MOSI</b> — Master Out Slave in for SSP1.
					O <b>TRACEDATA[2]</b> — Trace data, bit 2.
					I/O <b>GPIO7[21]</b> — General purpose digital input/output pin.
					- R — Function reserved.
					I/O <b>SGPIO6</b> — General purpose digital input/output pin.
					I/O <b>I2S1_TX_WS</b> — Transmit Word Select. It is driven by the master and received by the slave. Corresponds to the signal WS in the <i>I<sup>2</sup>S-bus specification</i> .
					AI/O <b>ADC1_7</b> — ADC1, input channel 7 or band gap output. Configure the pin as GPIO input and use the ADC function select register in the SCU to select the ADC.
PF_8	E6	-	[6] I; PU	[13] -	R — Function reserved.
					I/O <b>U0_UCLK</b> — Serial clock input/output for USART0 in synchronous mode.
					I <b>CTIN_2</b> — SCT input 2. Capture input 2 of timer 0.
					O <b>TRACEDATA[3]</b> — Trace data, bit 3.
					I/O <b>GPIO7[22]</b> — General purpose digital input/output pin.
					- R — Function reserved.
					I/O <b>SGPIO7</b> — General purpose digital input/output pin.
					- R — Function reserved.
					AI <b>ADC0_2</b> — ADC0, input channel 2. Configure the pin as GPIO input and use the ADC function select register in the SCU to select the ADC.

**Table 3. Pin description ...continued**

LCD, Ethernet, USB0, and USB1 functions are not available on all parts. See [Table 2](#).

Symbol	LBGA256	TFBGA100	Reset state	Type	Description
PF_9	D6	-	[6] [13]	I; PU	- R — Function reserved.
					I/O <b>U0_DIR</b> — RS-485/EIA-485 output enable/direction control for USART0.
					O <b>CTOUT_1</b> — SCT output 1. Match output 1 of timer 0.
					- R — Function reserved.
					I/O <b>GPIO7[23]</b> — General purpose digital input/output pin.
					- R — Function reserved.
					I/O <b>SGPIO3</b> — General purpose digital input/output pin.
- R — Function reserved.					
PF_10	A3	-	[6] [13]	I; PU	AI <b>ADC1_2</b> — ADC1, input channel 2. Configure the pin as GPIO input and use the ADC function select register in the SCU to select the ADC.
					- R — Function reserved.
					O <b>U0_TXD</b> — Transmitter output for USART0.
					- R — Function reserved.
					- R — Function reserved.
					I/O <b>GPIO7[24]</b> — General purpose digital input/output pin.
					- R — Function reserved.
I <b>SD_WP</b> — SD/MMC card write protect input.					
- R — Function reserved.					
PF_11	A2	-	[6] [13]	I; PU	AI <b>ADC0_5</b> — ADC0, input channel 5. Configure the pin as GPIO input and use the ADC function select register in the SCU to select the ADC.
					- R — Function reserved.
					I <b>U0_RXD</b> — Receiver input for USART0.
					- R — Function reserved.
					- R — Function reserved.
					I/O <b>GPIO7[25]</b> — General purpose digital input/output pin.
					- R — Function reserved.
O <b>SD_VOLT2</b> — SD/MMC bus voltage select output 2.					
- R — Function reserved.					
AI <b>ADC1_5</b> — ADC1, input channel 5. Configure the pin as GPIO input and use the ADC function select register in the SCU to select the ADC.					

**Table 3. Pin description ...continued**

LCD, Ethernet, USB0, and USB1 functions are not available on all parts. See [Table 2](#).

Symbol	LPGA256	TFBGA100	Reset state	Type	Description	
<b>Clock pins</b>						
CLK0	N5	K3	[5]	O; PU	O	<b>EMC_CLK0</b> — SDRAM clock 0.
					O	<b>CLKOUT</b> — Clock output pin.
					-	<b>R</b> — Function reserved.
					-	<b>R</b> — Function reserved.
					I/O	<b>SD_CLK</b> — SD/MMC card clock.
					O	<b>EMC_CLK01</b> — SDRAM clock 0 and clock 1 combined.
					I/O	<b>SSP1_SCK</b> — Serial clock for SSP1.
					I	<b>ENET_TX_CLK (ENET_REF_CLK)</b> — Ethernet Transmit Clock (MII interface) or Ethernet Reference Clock (RMII interface).
CLK1	T10	-	[5]	O; PU	O	<b>EMC_CLK1</b> — SDRAM clock 1.
					O	<b>CLKOUT</b> — Clock output pin.
					-	<b>R</b> — Function reserved.
					-	<b>R</b> — Function reserved.
					-	<b>R</b> — Function reserved.
					O	<b>CGU_OUT0</b> — CGU spare clock output 0.
					-	<b>R</b> — Function reserved.
					O	<b>I2S1_TX_MCLK</b> — I2S1 transmit master clock.
CLK2	D14	K6	[5]	O; PU	O	<b>EMC_CLK3</b> — SDRAM clock 3.
					O	<b>CLKOUT</b> — Clock output pin.
					-	<b>R</b> — Function reserved.
					-	<b>R</b> — Function reserved.
					I/O	<b>SD_CLK</b> — SD/MMC card clock.
					O	<b>EMC_CLK23</b> — SDRAM clock 2 and clock 3 combined.
					O	<b>I2S0_TX_MCLK</b> — I2S transmit master clock.
					I/O	<b>I2S1_RX_SCK</b> — Receive Clock. It is driven by the master and received by the slave. Corresponds to the signal SCK in the I <sup>2</sup> S-bus specification.
CLK3	P12	-	[5]	O; PU	O	<b>EMC_CLK2</b> — SDRAM clock 2.
					O	<b>CLKOUT</b> — Clock output pin.
					-	<b>R</b> — Function reserved.
					-	<b>R</b> — Function reserved.
					-	<b>R</b> — Function reserved.
					O	<b>CGU_OUT1</b> — CGU spare clock output 1.
					-	<b>R</b> — Function reserved.
					I/O	<b>I2S1_RX_SCK</b> — Receive Clock. It is driven by the master and received by the slave. Corresponds to the signal SCK in the I <sup>2</sup> S-bus specification.

**Debug pins**

**Table 3. Pin description ...continued**

LCD, Ethernet, USB0, and USB1 functions are not available on all parts. See [Table 2](#).

Symbol	LBGA256	TFBGA100	Reset state	Type	Description
DBGEN	L4	A6	[3] I	I	JTAG interface control signal. Also used for boundary scan. To use the part in functional mode, connect this pin in one of the following ways: <ul style="list-style-type: none"> <li>• Leave DBGEN open. The DBGEN pin is pulled up internally by a 50 kΩ resistor.</li> <li>• Tie DBGEN to VDDIO.</li> <li>• Pull DBGEN up to VDDIO with an external pull-up resistor.</li> </ul>
TCK/SWDCLK	J5	H2	[3] I; F	I	Test Clock for JTAG interface (default) or Serial Wire (SW) clock.
$\overline{\text{TRST}}$	M4	B4	[3] I; PU	I	Test Reset for JTAG interface.
TMS/SWDIO	K6	C4	[3] I; PU	I	Test Mode Select for JTAG interface (default) or SW debug data input/output.
TDO/SWO	K5	H3	[3] O	O	Test Data Out for JTAG interface (default) or SW trace output.
TDI	J4	G3	[3] I; PU	I	Test Data In for JTAG interface.
<b>USB0 pins</b>					
USB0_DP	F2	E1	[7] -	I/O	USB0 bidirectional D+ line.
USB0_DM	G2	E2	[7] -	I/O	USB0 bidirectional D- line.
USB0_VBUS	F1	E3	[7] [8] -	I/O	VBUS pin (power on USB cable). This pin includes an internal pull-down resistor of 64 kΩ (typical) ± 16 kΩ.
USB0_ID	H2	F1	[9] -	I	Indicates to the transceiver whether connected as an A-device (USB0_ID LOW) or B-device (USB0_ID HIGH). For OTG this pin has an internal pull-up resistor.
USB0_RREF	H1	F3	[9] -		12.0 kΩ (accuracy 1 %) on-board resistor to ground for current reference.
<b>USB1 pins</b>					
USB1_DP	F12	E9	[10] -	I/O	USB1 bidirectional D+ line.
USB1_DM	G12	E10	[10] -	I/O	USB1 bidirectional D- line.
<b>I<sup>2</sup>C-bus pins</b>					
I2C0_SCL	L15	D6	[11] I; F	I/O	I <sup>2</sup> C clock input/output. Open-drain output (for I <sup>2</sup> C-bus compliance).
I2C0_SDA	L16	E6	[11] I; F	I/O	I <sup>2</sup> C data input/output. Open-drain output (for I <sup>2</sup> C-bus compliance).
<b>Reset and wake-up pins</b>					
$\overline{\text{RESET}}$	D9	B6	[12] I; IA	I	External reset input: A LOW-going pulse as short as 50 ns on this pin resets the device, causing I/O ports and peripherals to take on their default states, and processor execution to begin at address 0. This pin does not have an internal pull-up.
WAKEUP0	A9	A4	[12] I; IA	I	External wake-up input; can raise an interrupt and can cause wake-up from any of the low power modes. A pulse with a duration > 45 ns wakes up the part. This pin does not have an internal pull-up.
WAKEUP1	A10	-	[12] I; IA	I	External wake-up input; can raise an interrupt and can cause wake-up from any of the low power modes. A pulse with a duration > 45 ns wakes up the part. This pin does not have an internal pull-up.
WAKEUP2	C9	-	[12] I; IA	I	External wake-up input; can raise an interrupt and can cause wake-up from any of the low power modes. A pulse with a duration > 45 ns wakes up the part. This pin does not have an internal pull-up.

**Table 3. Pin description ...continued**

LCD, Ethernet, USB0, and USB1 functions are not available on all parts. See [Table 2](#).

Symbol	LBGA256	TFBGA100	Reset state	Type	Description
WAKEUP3	D8	-	[12] I; IA	I	External wake-up input; can raise an interrupt and can cause wake-up from any of the low power modes. A pulse with a duration > 45 ns wakes up the part. This pin does not have an internal pull-up.
<b>ADC pins</b>					
ADCHS_0	E3	A2	[9] I; IA	I	12-bit high-speed ADC input channel 0.
ADCHS_1	C3	A1	[9] I; IA	I	12-bit high-speed ADC input channel 1.
ADCHS_2	A4	B3	[9] I; IA	I	12-bit high-speed ADC input channel 2.
ADCHS_3	A5	-	[9] I; IA	I	12-bit high-speed ADC input channel 3.
ADCHS_4	C6	-	[9] I; IA	I	12-bit high-speed ADC input channel 4.
ADCHS_5	B3	-	[9] I; IA	I	12-bit high-speed ADC input channel 5.
ADCHS_NEG	B5	A3	[9] I; IA	I/O	12-bit high-speed ADC reference voltage output or negative differential input.
ADC0_7	C5	-	[9] I; IA	I	10-bit ADC0 input channel 7.
<b>RTC</b>					
RTC_ALARM	A11	C3	[12] -	O	RTC controlled output. This pin has an internal pull-up. The reset state of this pin is LOW after POR. For all other types of reset, the reset state depends on the state of the RTC alarm interrupt.
RTCX1	A8	A5	[9] -	I	Input to the RTC 32 kHz ultra-low power oscillator circuit.
RTCX2	B8	B5	[9] -	O	Output from the RTC 32 kHz ultra-low power oscillator circuit.
<b>Crystal oscillator pins</b>					
XTAL1	D1	B1	[9] -	I	Input to the oscillator circuit and internal clock generator circuits.
XTAL2	E1	C1	[9] -	O	Output from the oscillator amplifier.
<b>Power and ground pins</b>					
USB0_VDDA 3V3_DRIVER	F3	D1	-	-	Separate analog 3.3 V power supply for driver.
USB0_VDDA3V3	G3	D2	-	-	USB 3.3 V separate power supply voltage.
USB0_VSSA_TERM	H3	D3	-	-	Dedicated analog ground for clean reference for termination resistors.
USB0_VSSA_REF	G1	F2	-	-	Dedicated clean analog ground for generation of reference currents and voltages.
VDDA	B4	B2	-	-	Analog power supply and 10-bit ADC reference voltage.
VBAT	B10	C5	-	-	RTC power supply: 3.3 V on this pin supplies power to the RTC.
VDDREG	F10, F9, L8, L7	E4, E5, F4	-	-	Main regulator power supply. Tie the VDDREG and VDDIO pins to a common power supply to ensure the same ramp-up time for both supply voltages.
VPP	E8	-	-	-	OTP programming voltage.

**Table 3. Pin description ...continued**LCD, Ethernet, USB0, and USB1 functions are not available on all parts. See [Table 2](#).

Symbol	LBGA256	TFBGA100	Reset state [2]	Type	Description
VDDIO	D7, E12, F7, F8, G10, H10, J6, J7, K7, L9, L10, N7, N13	F10, K5	-	-	I/O power supply. Tie the VDDREG and VDDIO pins to a common power supply to ensure the same ramp-up time for both supply voltages.
VDD	-	-	-	-	Power supply for main regulator, I/O, and OTP.
VSS	G9, H7, J10, J11, K8	-	-	-	Ground.
VSSIO	C4, D13, G6, G7, G8, H8, H9, J8, J9, K9, K10, M13, P7, P13	C8, D4, D5, G8, J3, J6	-	-	Ground.
VSSA	B2	C2	-	-	Analog ground.
<b>Not connected</b>					
-	B9	-	-	-	n.c.

[1] - = not pinned out.

[2] I = input, O = output, AI/O analog input/output, IA = inactive; PU = pull-up enabled (weak pull-up resistor pulls up pin to  $V_{DD(I/O)}$ ); F = floating. Reset state reflects the pin state at reset without boot code operation.[3] 5 V tolerant pad with 15 ns glitch filter (5 V tolerant if  $V_{DD(I/O)}$  present; if  $V_{DD(I/O)}$  not present, do not exceed 3.3 V); provides digital I/O functions with TTL levels and hysteresis; normal drive strength.[4] 5 V tolerant pad with 15 ns glitch filter (5 V tolerant if  $V_{DD(I/O)}$  present; if  $V_{DD(I/O)}$  not present, do not exceed 3.3 V) providing digital I/O functions with TTL levels, and hysteresis; high drive strength.[5] 5 V tolerant pad with 15 ns glitch filter (5 V tolerant if  $V_{DD(I/O)}$  present; if  $V_{DD(I/O)}$  not present, do not exceed 3.3 V) providing high-speed digital I/O functions with TTL levels and hysteresis.

- [6] 5 V tolerant pad providing digital I/O functions (with TTL levels and hysteresis) and analog input or output (5 V tolerant if  $V_{DD(I/O)}$  present; if  $V_{DD(I/O)}$  not present, do not exceed 3.3 V). When configured as a ADC input or DAC output, the pin is not 5 V tolerant and the digital section of the pad must be disabled by setting the pin to an input function and disabling the pull-up resistor through the pin's SFSP register.
- [7] 5 V tolerant transparent analog pad.
- [8] For maximum load  $C_L = 6.5 \mu\text{F}$  and maximum resistance  $R_{pd} = 80 \text{ k}\Omega$ , the VBUS signal takes about 2 s to fall from  $V_{BUS} = 5 \text{ V}$  to  $V_{BUS} = 0.2 \text{ V}$  when it is no longer driven.
- [9] Transparent analog pad. Not 5 V tolerant.
- [10] Pad provides USB functions (5 V tolerant if  $V_{DD(I/O)}$  present; if  $V_{DD(I/O)}$  not present, do not exceed 3.3 V). It is designed in accordance with the USB specification, revision 2.0 (Full-speed and Low-speed mode only).
- [11] Open-drain 5 V tolerant digital I/O pad, compatible with I<sup>2</sup>C-bus Fast Mode Plus specification. This pad requires an external pull-up to provide output functionality. When power is switched off, this pin connected to the I<sup>2</sup>C-bus is floating and does not disturb the I<sup>2</sup>C lines.
- [12] 5 V tolerant pad with 20 ns glitch filter; provides digital I/O functions with open-drain output with weak pull-up resistor and hysteresis.
- [13] To minimize interference on the 12-bit ADC signal lines, do not configure the digital signal as output when using the 12-bit ADC. See [Table 45](#).

## 7. Functional description

### 7.1 Architectural overview

The ARM Cortex-M4 includes three AHB-Lite buses: the system bus, the I-code bus, and the D-code bus. The I-code and D-code core buses allow for concurrent code and data accesses from different slave ports.

The LPC43S70 use a multi-layer AHB matrix to connect the ARM Cortex-M4 buses and other bus masters to peripherals in a flexible manner that optimizes performance by allowing peripherals that are on different slaves ports of the matrix to be accessed simultaneously by different bus masters.

An ARM Cortex-M0 coprocessor is included in the LPC43S70, capable of off-loading the main ARM Cortex-M4 application processor. Most peripheral interrupts are connected to both processors. The processors communicate with each other via an interprocessor communication protocol.

### 7.2 ARM Cortex-M4 processor

The ARM Cortex-M4 CPU incorporates a 3-stage pipeline, uses a Harvard architecture with separate local instruction and data buses as well as a third bus for peripherals, and includes an internal prefetch unit that supports speculative branching. The ARM Cortex-M4 supports single-cycle digital signal processing and SIMD instructions. A hardware floating-point processor is integrated in the core. The processor includes a NVIC with up to 53 interrupts.

### 7.3 ARM Cortex-M0 processors

The ARM Cortex-M0 processors are general purpose, 32-bit microprocessors, which offer high performance and very low power consumption. The ARM Cortex-M0 processor uses a 3-stage pipeline von Neumann architecture and a small but powerful instruction set providing high-end processing hardware. The processors each incorporate an NVIC with 32 interrupts.

#### 7.3.1 ARM Cortex-M0 coprocessor

The M0 coprocessor resides on the same AHB multi-layer matrix as the main Cortex-M0 core. The coprocessor can be used to off-load multiple tasks from the main Cortex-M4 processor.

#### 7.3.2 ARM Cortex-M0 subsystem

The Cortex-M0 subsystem can be used to manage the SGPIO and SPI peripherals on the M0 subsystem multilayer matrix but any other peripheral as well. The M0 subsystem is separated by a bridge from the main AHB matrix. The M0 subsystem AHB matrix has two SRAM blocks which allows to run the Cortex-M0 subsystem at full speed independently from the main matrix.

One application of using the subsystem is to reduce power, for example when the main matrix runs at a very low speed and the M0 subsystem monitors activity and increases the main matrix speed when needed.

One of the two SRAM blocks connected to the subsystem AHB matrix is typically used for code running on the M0 subsystem and the other SRAM block for data. This allows other bus masters to access the data SRAM without interrupting the M0 processor instruction fetches and thereby stalling the M0 subsystem.

The M0 subsystem matrix runs at an asynchronous speed from the main matrix. This allows to operate the SGPIO at any desired frequency. The M0 subsystem can control the SGPIO in a deterministic way, without incurring latency that occurs when the M4 controls the SGPIO through a bridge.

## 7.4 Interprocessor communication

The ARM Cortex-M4 and ARM Cortex-M0 interprocessor communication is based on using shared SRAM as mailbox and one processor raising an interrupt on the other processor's NVIC, for example after it has delivered a new message in the mailbox. The receiving processor can reply by raising an interrupt on the sending processor's NVIC to acknowledge the message.

### 7.5 AHB multilayer matrix

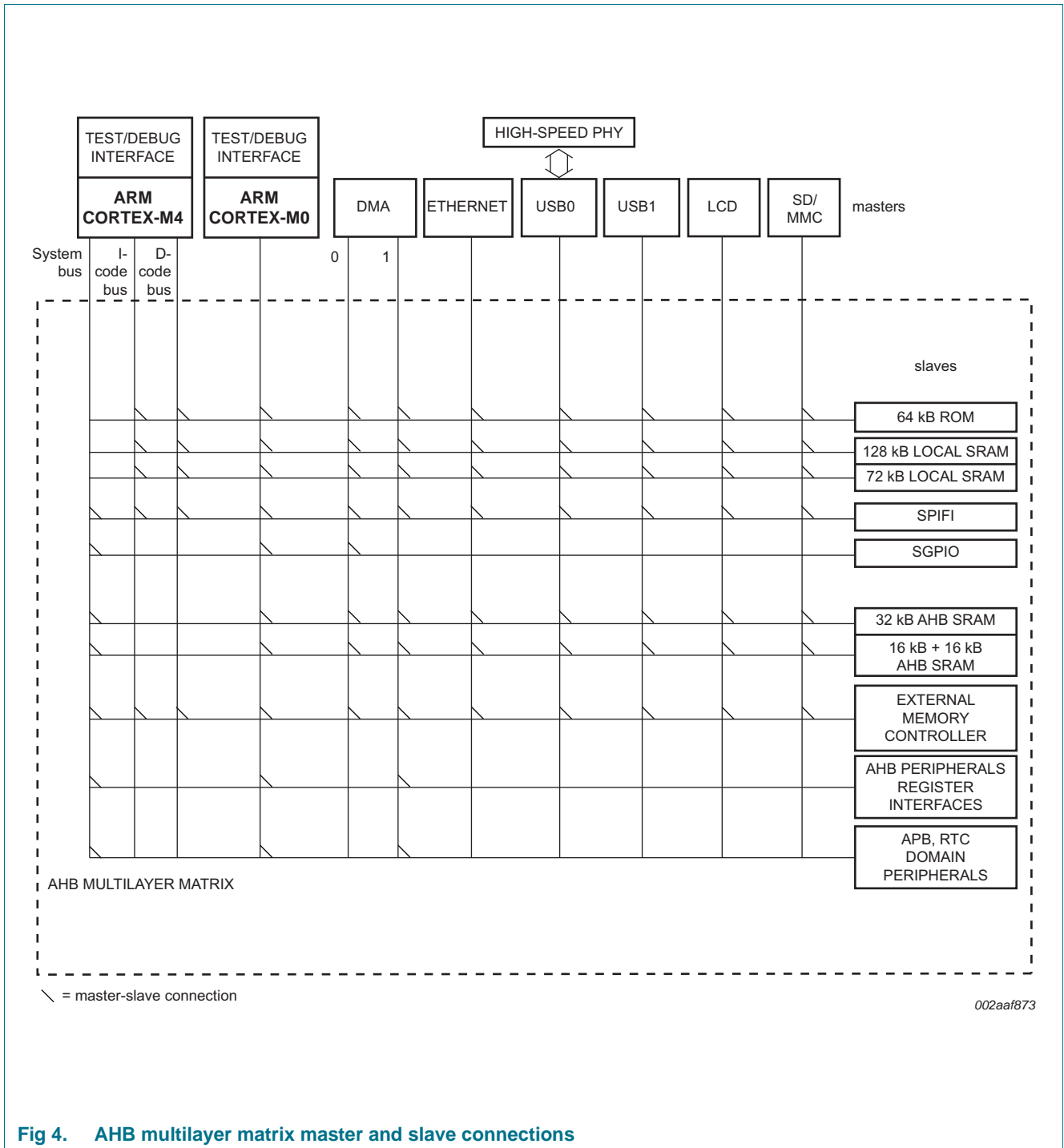

Fig 4. AHB multilayer matrix master and slave connections

### 7.6 Nested Vectored Interrupt Controller (NVIC)

The NVIC is an integral part of the Cortex-M4. The tight coupling to the CPU allows for low interrupt latency and efficient processing of late arriving interrupts.

Each ARM Cortex-M0 coprocessor has its own NVIC with 32 vectored interrupts. Most peripheral interrupts are shared between the two Cortex-M0 cores and the Cortex-M4 NVICs.

### 7.6.1 Features

- ARM Cortex-M4 NVIC:
  - Controls system exceptions and peripheral interrupts.
  - Up to 53 vectored interrupts.
  - Eight programmable interrupt priority levels with hardware priority level masking.
  - Relocatable vector table.
  - Non-Maskable Interrupt (NMI).
  - Software interrupt generation.
- ARM Cortex-M0 and ARM Cortex-M0 subsystem NVIC:
  - Control system exceptions and peripheral interrupts.
  - Up to 32 vectored interrupts.
  - Four programmable priority levels with hardware priority level masking.

### 7.6.2 Interrupt sources

Each peripheral device has one interrupt line connected to the NVIC but may have several interrupt flags. Individual interrupt flags may also represent more than one interrupt source.

## 7.7 System Tick timer (SysTick)

The ARM Cortex-M4 includes a system tick timer (SysTick) that is intended to generate a dedicated SYSTICK exception, typically at 10 ms interval.

**Remark:** The SysTick is not included in the ARM Cortex-M0 core.

## 7.8 Event router

The event router combines various internal signals, interrupts, and the external interrupt pins (WAKEUP[3:0]) to create an interrupt in the NVIC if enabled and to create a wake-up signal to the ARM core and the CCU for waking up from Sleep, Deep-sleep, Power-down, and Deep power-down modes. Individual events can be configured as edge or level sensitive and can be enabled or disabled in the event router. The event router can be battery powered.

The following events if enabled in the event router can create a wake-up signal and/or an interrupt:

- External pins WAKEUP0/1/2/3 and  $\overline{\text{RESET}}$
- Alarm timer, RTC, WWDT, BOD interrupts
- C\_CAN and QEI interrupts
- Ethernet, USB0, USB1 signals
- Selected outputs of combined timers (SCT and timer0/1/3)

## 7.9 Global Input Multiplexer Array (GIMA)

The GIMA allows to route signals to event-driven peripheral targets like the SCT, timers, event router, or the ADCs.

### 7.9.1 Features

- Single selection of a source.
- Signal inversion.
- Can capture a pulse if the input event source is faster than the target clock.
- Synchronization of input event and target clock.
- Single-cycle pulse generation for target.

## 7.10 On-chip static RAM

The LPC43S70 support 200 kB local SRAM and an additional 64 kB AHB SRAM with separate bus master access for higher throughput and individual power control for low power operation. See [Section 7.22.9.1 “Memory retention in Power-down modes”](#).

## 7.11 In-System Programming (ISP)

In-System programming (ISP) is programming or reprogramming the on-chip SRAM memory, using the boot loader software and the USART0 serial port. This can be done when the part resides in the end-user board. ISP allows to load data into on-chip SRAM and execute code from on-chip SRAM.

## 7.12 Boot ROM

The internal ROM memory is used to store the boot code of the LPC43S70. After a reset, the ARM processor will start its code execution from this memory.

The boot ROM memory includes the following features:

- ROM memory size is 64 kB.
- Supports booting from UART interfaces and external static memory such as NOR flash, SPI flash, quad SPI flash.
- Includes APIs for OTP and AES programming.
- Includes a flexible USB device stack that supports Human Interface Device (HID), Mass Storage Class (MSC), and Device Firmware Upgrade (DFU) drivers.

Several boot modes are available depending on the values of the OTP bits BOOT\_SRC. If the OTP memory is not programmed or the BOOT\_SRC bits are all zero, the boot mode is determined by the states of the boot pins P2\_9, P2\_8, P1\_2, and P1\_1.

**Table 4. Boot mode when OTP BOOT\_SRC bits are programmed**

Boot mode	BOOT_SRC bit 3	BOOT_SRC bit 2	BOOT_SRC bit 1	BOOT_SRC bit 0	Description
Pin state	0	0	0	0	Boot source is defined by the reset state of P1_1, P1_2, P2_8 pins, and P2_9. See <a href="#">Table 5</a> .
USART0	0	0	0	1	Boot from device connected to USART0 using pins P2_0 and P2_1.
SPIFI	0	0	1	0	Boot from Quad SPI flash connected to the SPIFI interface using pins P3_3 to P3_8.
EMC 8-bit	0	0	1	1	Boot from external static memory (such as NOR flash) using CS0 and an 8-bit data bus.
EMC 16-bit	0	1	0	0	Boot from external static memory (such as NOR flash) using CS0 and a 16-bit data bus.
EMC 32-bit	0	1	0	1	Boot from external static memory (such as NOR flash) using CS0 and a 32-bit data bus.
USB0	0	1	1	0	Boot from USB0.
USB1	0	1	1	1	Boot from USB1.
SPI (SSP)	1	0	0	0	Boot from SPI flash connected to the SSP0 interface on P3_3 (function SSP0_SCK), P3_6 (function SSP0_SSEL), P3_7 (function SSP0_MISO), and P3_8 (function SSP0_MOSI) <sup>[1]</sup> .
USART3	1	0	0	1	Boot from device connected to USART3 using pins P2_3 and P2_4.

[1] The boot loader programs the appropriate pin function at reset to boot using either SSP0 or SPIFI.

**Remark:** Pin functions for SPIFI and SSP0 boot are different.

**Table 5. Boot mode when OPT BOOT\_SRC bits are zero**

Boot mode	Pins				Description
	P2_9	P2_8	P1_2	P1_1	
USART0	LOW	LOW	LOW	LOW	Boot from device connected to USART0 using pins P2_0 and P2_1.
SPIFI	LOW	LOW	LOW	HIGH	Boot from Quad SPI flash connected to the SPIFI interface on P3_3 to P3_8 <sup>[1]</sup> .
EMC 8-bit	LOW	LOW	HIGH	LOW	Boot from external static memory (such as NOR flash) using CS0 and an 8-bit data bus.
EMC 16-bit	LOW	LOW	HIGH	HIGH	Boot from external static memory (such as NOR flash) using CS0 and a 16-bit data bus.
EMC 32-bit	LOW	HIGH	LOW	LOW	Boot from external static memory (such as NOR flash) using CS0 and a 32-bit data bus.
USB0	LOW	HIGH	LOW	HIGH	Boot from USB0
USB1	LOW	HIGH	HIGH	LOW	Boot from USB1.
SPI (SSP)	LOW	HIGH	HIGH	HIGH	Boot from SPI flash connected to the SSP0 interface on P3_3 (function SSP0_SCK), P3_6 (function SSP0_SSEL), P3_7 (function SSP0_MISO), and P3_8 (function SSP0_MOSI) <sup>[1]</sup> .
USART3	HIGH	LOW	LOW	LOW	Boot from device connected to USART3 using pins P2_3 and P2_4.

[1] The boot loader programs the appropriate pin function at reset to boot using either SSP0 or SPIFI.

**Remark:** Pin functions for SPIFI and SSP0 boot are different.

### 7.13 Memory mapping

The memory map shown in [Figure 5](#) and [Figure 6](#) is global to both the Cortex-M4 and the Cortex-M0 processors and all SRAM is shared between both processors. Each processor uses its own ARM private bus memory map for the NVIC and other system functions.

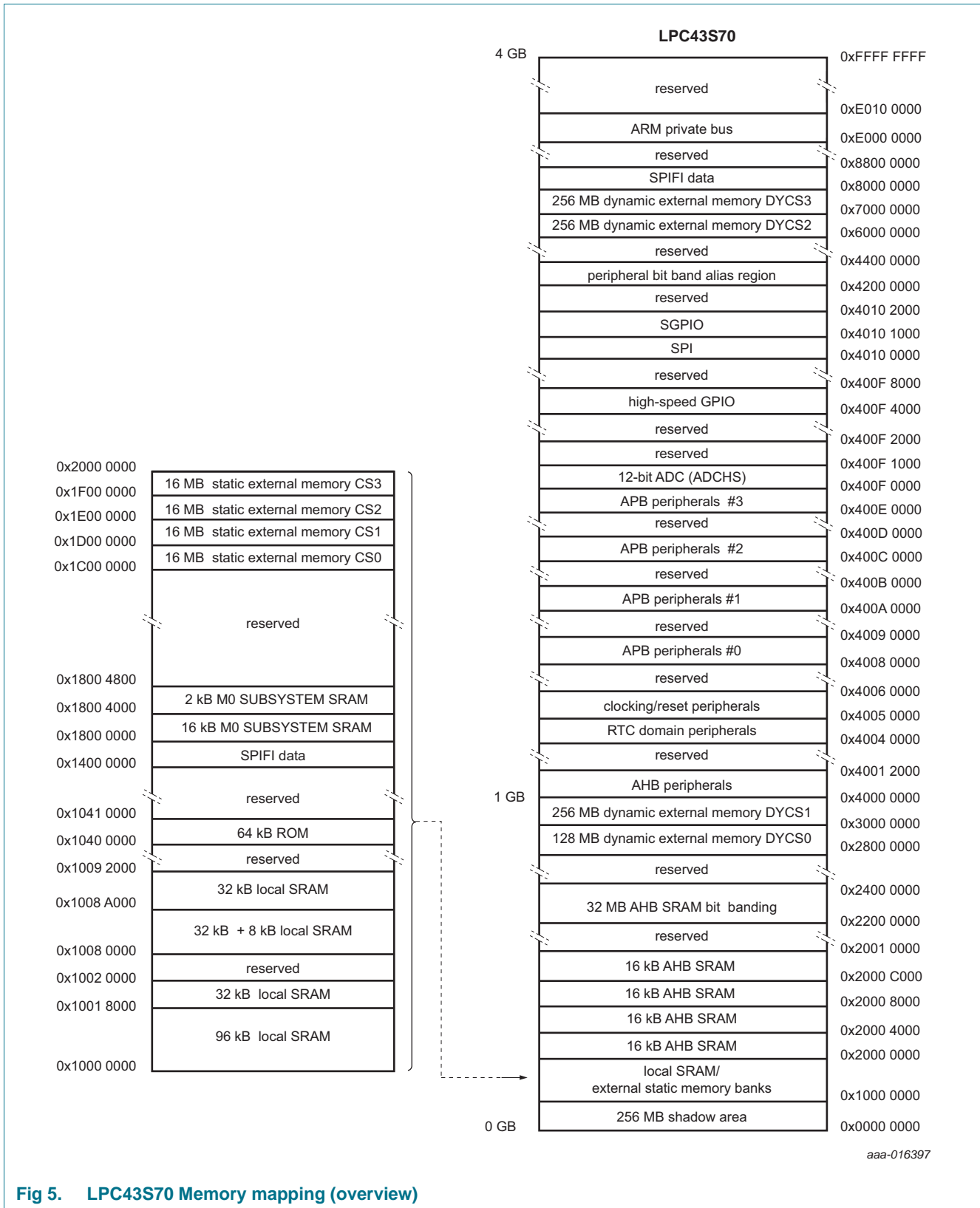
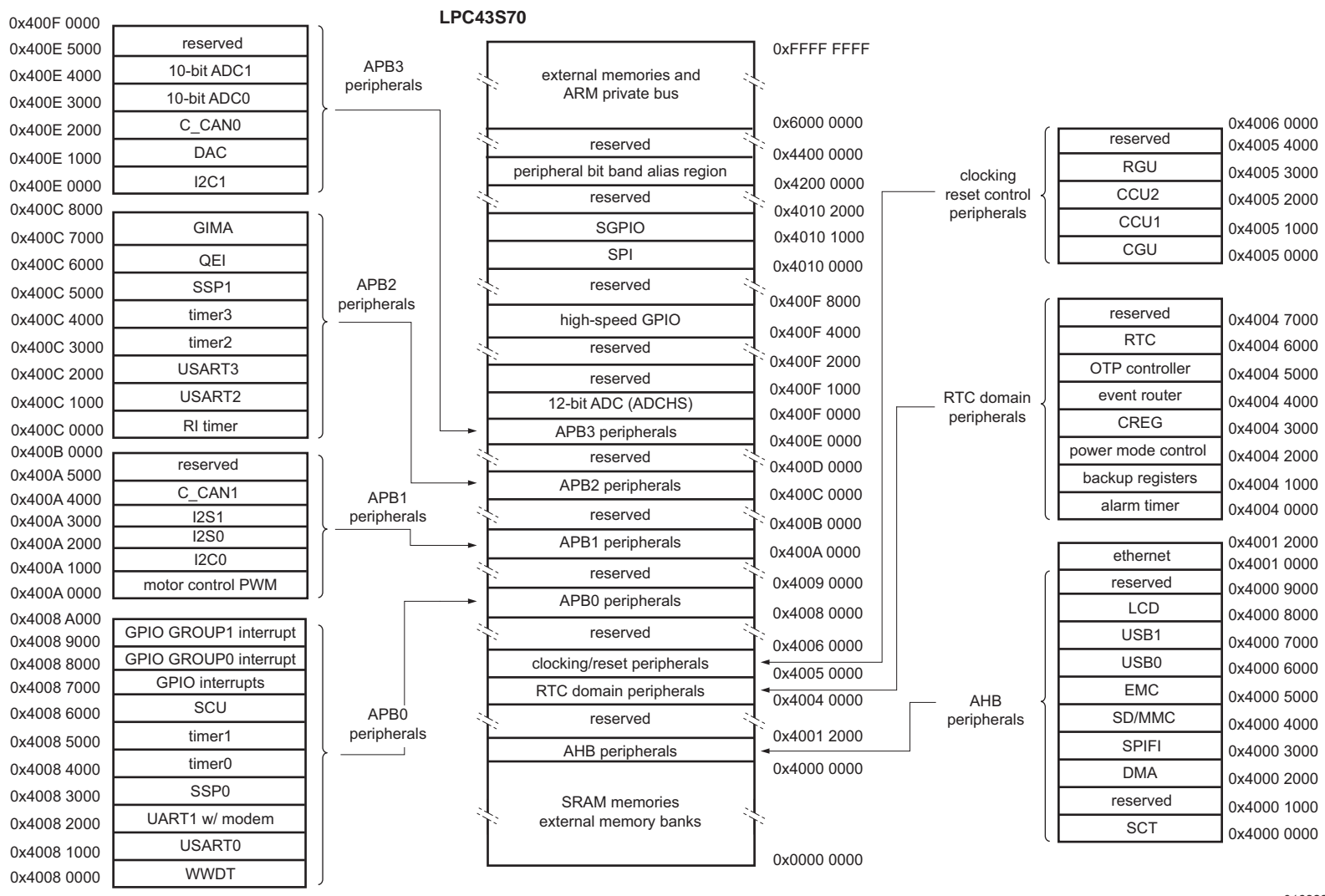

Fig 5. LPC43S70 Memory mapping (overview)



aaa-016398

Fig 6. LPC43S70 Memory mapping (peripherals)

## 7.14 One-Time Programmable (OTP) memory

The OTP provides 64 bit of memory for general-purpose use. 256 bit of OTP memory are available to store two AES keys in two memory banks. One bank is encrypted.

## 7.15 General Purpose I/O (GPIO)

The LPC43S70 provide 8 GPIO ports with up to 31 GPIO pins each.

Device pins that are not connected to a specific peripheral function are controlled by the GPIO registers. Pins may be dynamically configured as inputs or outputs. Separate registers allow setting or clearing any number of outputs simultaneously. The value of the output register may be read back as well as the current state of the port pins.

All GPIO pins default to inputs with pull-up resistors enabled on reset.

### 7.15.1 Features

- Accelerated GPIO functions:
  - GPIO registers are located on the AHB so that the fastest possible I/O timing can be achieved.
  - Mask registers allow treating sets of port bits as a group, leaving other bits unchanged.
  - All GPIO registers are byte and half-word addressable.
  - Entire port value can be written in one instruction.
- Bit-level set and clear registers allow a single instruction set or clear of any number of bits in one port.
- Direction control of individual bits.
- All I/O default to inputs after reset.
- Up to eight GPIO pins can be selected from all GPIO pins to create an edge- or level-sensitive GPIO interrupt request (GPIO interrupts).
- Two GPIO group interrupts can be triggered by any pin or pins in each port (GPIO group0 and group1 interrupts).

## 7.16 Configurable digital peripherals

### 7.16.1 State Configurable Timer (SCT) subsystem

The SCT allows a wide variety of timing, counting, output modulation, and input capture operations. The inputs and outputs of the SCT are shared with the capture and match inputs/outputs of the 32-bit general purpose counter/timers.

The SCT can be configured as two 16-bit counters or a unified 32-bit counter. In the two-counter case, in addition to the counter value the following operational elements are independent for each half:

- State variable
- Limit, halt, stop, and start conditions
- Values of Match/Capture registers, plus reload or capture control values

In the two-counter case, the following operational elements are global to the SCT, but the last three can use match conditions from either counter:

- Clock selection
- Inputs
- Events
- Outputs
- Interrupts

#### 7.16.1.1 Features

- Two 16-bit counters or one 32-bit counter.
- Counter(s) clocked by bus clock or selected input.
- Up counter(s) or up-down counter(s).
- State variable allows sequencing across multiple counter cycles.
- Event combines input or output condition and/or counter match in a specified state.
- Events control outputs and interrupts.
- Selected event(s) can limit, halt, start, or stop a counter.
- Supports:
  - 8 inputs (one input connected internally)
  - 16 outputs
  - 16 match/capture registers
  - 16 events
  - 32 states

#### 7.16.2 Serial GPIO (SGPIO)

The Serial GPIOs offer standard GPIO functionality enhanced with features to accelerate serial stream processing.

##### 7.16.2.1 Features

- Each SGPIO input/output slice can be used to perform a serial to parallel or parallel to serial data conversion.
- 16 SGPIO input/output slices each with a 32-bit FIFO that can shift the input value from a pin or an output value to a pin with every cycle of a shift clock.
- Each slice is double-buffered.
- Interrupt is generated on a full FIFO, shift clock, or pattern match.
- Slices can be concatenated to increase buffer size.
- Each slice has a 32-bit pattern match filter.

### 7.17 AHB peripherals

#### 7.17.1 AES decryption/encryption

The hardware AES engine can decode and encode data using the AES algorithm in conjunction with a 128-bit key.

The AES encryption and decryption features are accessible through the ROM-based AES API.

### 7.17.1.1 Features

- On-chip API support for AES encryption and decryption.
- Two 128-bit OTP memories for AES key storage and customer use. One OTP memory bank is encrypted.
- Random number generator (RNG) accessible through AES API.
- Unique ID for each device.
- Decoding of external flash data connected to the quad SPI Flash Interface (SPIFI).
- Secure storage of encryption and decryption keys.
- Support for CMAC hash calculation to authenticate encrypted data.
- AES engine supports the following modes:
  - Electronic Code Block (ECB) mode (encryption and decryption) with 128-bit key.
  - Cypher Block Chaining (CBC) mode (encryption and decryption) with 128-bit key.
- The AES engine is compliant with the FIPS (Federal Information Processing Standard) Publication 197, Advanced Encryption Standard (AES).
- Random Number Generator (RNG) is supported by the AES API and passes the following tests:
  - diehard
  - FIPS\_140-1
  - NIST
- Data is processed in little endian mode. This means that the first byte read from flash is integrated into the AES codeword as least significant byte. The 16th byte read from flash is the most significant byte of the first AES codeword.
- AES peak engine performance of 0.5 byte/clock cycle.
- DMA transfers supported through the GPDMA.

### 7.17.2 General Purpose DMA (GPDMA)

The DMA controller allows peripheral-to memory, memory-to-peripheral, peripheral-to-peripheral, and memory-to-memory transactions. Each DMA stream provides unidirectional serial DMA transfers for a single source and destination. For example, a bidirectional port requires one stream for transmit and one for receives. The source and destination areas can each be either a memory region or a peripheral for master 1, but only memory for master 0.

#### 7.17.2.1 Features

- Eight DMA channels. Each channel can support an unidirectional transfer.
- 16 DMA request lines.
- Single DMA and burst DMA request signals. Each peripheral connected to the DMA Controller can assert either a burst DMA request or a single DMA request. The DMA burst size is set by programming the DMA Controller.
- Memory-to-memory, memory-to-peripheral, peripheral-to-memory, and peripheral-to-peripheral transfers are supported.

- Scatter or gather DMA is supported through the use of linked lists. This means that the source and destination areas do not have to occupy contiguous areas of memory.
- Hardware DMA channel priority.
- AHB slave DMA programming interface. The DMA Controller is programmed by writing to the DMA control registers over the AHB slave interface.
- Two AHB bus masters for transferring data. These interfaces transfer data when a DMA request goes active. Master 1 can access memories and peripherals (except SGPIO and SPI). Master 0 can access memories on the main AHB matrix and peripherals and memories on the MOSUB bus.
- 32-bit AHB master bus width.
- Incrementing or non-incrementing addressing for source and destination.
- Programmable DMA burst size. The DMA burst size can be programmed to more efficiently transfer data.
- Internal four-word FIFO per channel.
- Supports 8, 16, and 32-bit wide transactions.
- Big-endian and little-endian support. The DMA Controller defaults to little-endian mode on reset.
- An interrupt to the processor can be generated on a DMA completion or when a DMA error has occurred.
- Raw interrupt status. The DMA error and DMA count raw interrupt status can be read prior to masking.

### 7.17.3 SPI Flash Interface (SPIFI)

The SPI Flash Interface allows low-cost serial flash memories to be connected to the ARM Cortex-M4 processor with little performance penalty compared to parallel flash devices with higher pin count.

After a few commands configure the interface at startup, the entire flash content is accessible as normal memory using byte, halfword, and word accesses by the processor and/or DMA channels. Erasure and programming are handled by simple sequences of commands.

Many serial flash devices use a half-duplex command-driven SPI protocol for device setup and initialization and then move to a half-duplex, command-driven 4-bit protocol for normal operation. Different serial flash vendors and devices accept or require different commands and command formats. SPIFI provides sufficient flexibility to be compatible with common flash devices and includes extensions to help insure compatibility with future devices.

#### 7.17.3.1 Features

- Interfaces to serial flash memory in the main memory map.
- Supports classic and 4-bit bidirectional serial protocols.
- Half-duplex protocol compatible with various vendors and devices.
- Data rates of up to 52 MB per second.
- Supports DMA access.

#### 7.17.4 SD/MMC card interface

The SD/MMC card interface supports the following modes to control:

- Secure Digital memory (SD version 3.0)
- Secure Digital I/O (SDIO version 2.0)
- Consumer Electronics Advanced Transport Architecture (CE-ATA version 1.1)
- MultiMedia Cards (MMC version 4.4)

#### 7.17.5 External Memory Controller (EMC)

The LPC43S70 EMC is a Memory Controller peripheral offering support for asynchronous static memory devices such as RAM, ROM, and flash. In addition, it can be used as an interface with off-chip memory-mapped devices and peripherals.

##### 7.17.5.1 Features

- Dynamic memory interface support including single data rate SDRAM.
- Asynchronous static memory device support including RAM, ROM, and flash, with or without asynchronous page mode.
- Low transaction latency.
- Read and write buffers to reduce latency and to improve performance.
- 8/16/32 data and 24 address lines wide static memory support.
- 16 bit and 32 bit wide chip select SDRAM memory support.
- Static memory features include:
  - Asynchronous page mode read
  - Programmable Wait States
  - Bus turnaround delay
  - Output enable and write enable delays
  - Extended wait
- Four chip selects for synchronous memory and four chip selects for static memory devices.
- Power-saving modes dynamically control EMC\_CKEOUT and EMC\_CLK signals to SDRAMs.
- Dynamic memory self-refresh mode controlled by software.
- Controller supports 2048 (A0 to A10), 4096 (A0 to A11), and 8192 (A0 to A12) row address synchronous memory parts. That is typical 512 MB, 256 MB, and 128 MB parts, with 4, 8, 16, or 32 data bits per device.
- Separate reset domains allow the for auto-refresh through a chip reset if desired.
- SDRAM clock can run at full or half the Cortex-M4 core frequency.

**Note:** Synchronous static memory devices (synchronous burst mode) are not supported.

#### 7.17.6 High-speed USB Host/Device/OTG interface (USB0)

The USB OTG module allows the LPC43S70 to connect directly to a USB Host such as a PC (in device mode) or to a USB Device in host mode.

### 7.17.6.1 Features

- Contains UTMI+ compliant transceiver (PHY).
- Complies with *Universal Serial Bus specification 2.0*.
- Complies with *USB On-The-Go supplement*.
- Complies with *Enhanced Host Controller Interface Specification*.
- Supports auto USB 2.0 mode discovery.
- Supports all high-speed USB-compliant peripherals.
- Supports all full-speed USB-compliant peripherals.
- Supports software Host Negotiation Protocol (HNP) and Session Request Protocol (SRP) for OTG peripherals.
- Supports interrupts.
- This module has its own, integrated DMA engine.
- USB interface electrical test software included in ROM USB stack.

### 7.17.7 High-speed USB Host/Device interface with ULPI (USB1)

The USB1 interface can operate as a full-speed USB Host/Device interface or can connect to an external ULPI PHY for High-speed operation.

#### 7.17.7.1 Features

- Complies with *Universal Serial Bus specification 2.0*.
- Complies with *Enhanced Host Controller Interface Specification*.
- Supports auto USB 2.0 mode discovery.
- Supports all high-speed USB-compliant peripherals if connected to external ULPI PHY.
- Supports all full-speed USB-compliant peripherals.
- Supports interrupts.
- This module has its own, integrated DMA engine.
- USB interface electrical test software included in ROM USB stack.

### 7.17.8 LCD controller

**Remark:** The LCD controller is available on the LPC4370FET256 parts. See [Table 2](#).

The LCD controller provides all of the necessary control signals to interface directly to a variety of color and monochrome LCD panels. Both STN (single and dual panel) and TFT panels can be operated. The display resolution is selectable and can be up to 1024 × 768 pixels. Several color modes are provided, up to a 24-bit true-color non-palettized mode. An on-chip 512-byte color palette allows reducing bus utilization (i.e. memory size of the displayed data) while still supporting a large number of colors.

The LCD interface includes its own DMA controller to allow it to operate independently of the CPU and other system functions. A built-in FIFO acts as a buffer for display data, providing flexibility for system timing. Hardware cursor support can further reduce the amount of CPU time needed to operate the display.

### 7.17.8.1 Features

- AHB master interface to access frame buffer.
- Setup and control via a separate AHB slave interface.
- Dual 16-deep programmable 64-bit wide FIFOs for buffering incoming display data.
- Supports single and dual-panel monochrome Super Twisted Nematic (STN) displays with 4-bit or 8-bit interfaces.
- Supports single and dual-panel color STN displays.
- Supports Thin Film Transistor (TFT) color displays.
- Programmable display resolution including, but not limited to: 320 × 200, 320 × 240, 640 × 200, 640 × 240, 640 × 480, 800 × 600, and 1024 × 768.
- Hardware cursor support for single-panel displays.
- 15 gray-level monochrome, 3375 color STN, and 32 K color palettized TFT support.
- 1, 2, or 4 bits-per-pixel (bpp) palettized displays for monochrome STN.
- 1, 2, 4, or 8 bpp palettized color displays for color STN and TFT.
- 16 bpp true-color non-palettized for color STN and TFT.
- 24 bpp true-color non-palettized for color TFT.
- Programmable timing for different display panels.
- 256 entry, 16-bit palette RAM, arranged as a 128 × 32-bit RAM.
- Frame, line, and pixel clock signals.
- AC bias signal for STN, data enable signal for TFT panels.
- Supports little and big-endian, and Windows CE data formats.
- LCD panel clock may be generated from the peripheral clock, or from a clock input pin.

## 7.17.9 Ethernet

### 7.17.9.1 Features

- 10/100 Mbit/s
- DMA support
- Power management remote wake-up frame and magic packet detection
- Supports both full-duplex and half-duplex operation
  - Supports CSMA/CD Protocol for half-duplex operation.
  - Supports IEEE 802.3x flow control for full-duplex operation.
  - Optional forwarding of received pause control frames to the user application in full-duplex operation.
  - Back-pressure support for half-duplex operation.
  - Automatic transmission of zero-quanta pause frame on deassertion of flow control input in full-duplex operation.
- Supports IEEE1588 time stamping and IEEE 1588 advanced time stamping (IEEE 1588-2008 v2).

## 7.18 Digital serial peripherals

### 7.18.1 UART1

The LPC43S70 contain one UART with standard transmit and receive data lines, UART1 also provides a full modem control handshake interface and support for RS-485/9-bit mode allowing both software address detection and automatic address detection using 9-bit mode.

UART1 includes a fractional baud rate generator. Standard baud rates such as 115200 Bd can be achieved with any crystal frequency above 2 MHz.

#### 7.18.1.1 Features

- Maximum UART data bit rate of 8 MBit/s.
- 16 B Receive and Transmit FIFOs.
- Register locations conform to 16C550 industry standard.
- Receiver FIFO trigger points at 1 B, 4 B, 8 B, and 14 B.
- Built-in fractional baud rate generator covering wide range of baud rates without a need for external crystals of particular values.
- Auto baud capabilities and FIFO control mechanism that enables software flow control implementation.
- Equipped with standard modem interface signals. This module also provides full support for hardware flow control.
- Support for RS-485/9-bit/EIA-485 mode (UART1).
- DMA support.

### 7.18.2 USART0/2/3

The LPC43S70 contain three USARTs. In addition to standard transmit and receive data lines, the USARTs support a synchronous mode.

The USARTs include a fractional baud rate generator. Standard baud rates such as 115200 Bd can be achieved with any crystal frequency above 2 MHz.

#### 7.18.2.1 Features

- Maximum UART data bit rate of 8 MBit/s.
- 16 B Receive and Transmit FIFOs.
- Register locations conform to 16C550 industry standard.
- Receiver FIFO trigger points at 1 B, 4 B, 8 B, and 14 B.
- Built-in fractional baud rate generator covering wide range of baud rates without a need for external crystals of particular values.
- Auto baud capabilities and FIFO control mechanism that enables software flow control implementation.
- Support for RS-485/9-bit/EIA-485 mode.
- USART3 includes an IrDA mode to support infrared communication.
- All USARTs have DMA support.
- Support for synchronous mode at a data bit rate of up to 8 Mbit/s.

- Smart card mode conforming to ISO7816 specification

### 7.18.3 SPI serial I/O controller

The LPC43S70 contain one SPI controller. SPI is a full duplex serial interface designed to handle multiple masters and slaves connected to a given bus. Only a single master and a single slave can communicate on the interface during a given data transfer. During a data transfer the master always sends 8 bits to 16 bits of data to the slave, and the slave always sends 8 bits to 16 bits of data to the master.

#### 7.18.3.1 Features

- Maximum SPI data bit rate 25 MHz in master and slave modes.
- Compliant with SPI specification
- Synchronous, serial, full duplex communication
- Combined SPI master and slave
- Maximum data bit rate of one eighth of the input clock rate
- 8 bits to 16 bits per transfer

### 7.18.4 SSP serial I/O controller

**Remark:** The LPC43S70 contain two SSP controllers.

The SSP controller is capable of operation on a SPI, 4-wire SSI, or Microwire bus. It can interact with multiple masters and slaves on the bus. Only a single master and a single slave can communicate on the bus during a given data transfer. The SSP supports full duplex transfers, with frames of 4 bits to 16 bits of data flowing from the master to the slave and from the slave to the master. In practice, often only one of these data flows carries meaningful data.

#### 7.18.4.1 Features

- Maximum SSP speed in full-duplex mode of 25 Mbit/s; for transmit only 50 Mbit/s (master) and 15 Mbit/s (slave).
- Compatible with Motorola SPI, 4-wire Texas Instruments SSI, and National Semiconductor Microwire buses
- Synchronous serial communication
- Master or slave operation
- 8-frame FIFOs for both transmit and receive
- 4-bit to 16-bit frame
- DMA transfers supported by GPDMA

### 7.18.5 I<sup>2</sup>C-bus interface

**Remark:** The LPC43S70 each contain two I<sup>2</sup>C-bus interfaces.

The I<sup>2</sup>C-bus is bidirectional for inter-IC control using only two wires: a Serial Clock line (SCL) and a Serial Data line (SDA). Each device is recognized by a unique address and can operate as either a receiver-only device (e.g., an LCD driver) or a transmitter with the capability to both receive and send information (such as memory). Transmitters and/or

receivers can operate in either master or slave mode, depending on whether the chip has to initiate a data transfer or is only addressed. The I<sup>2</sup>C is a multi-master bus and can be controlled by more than one bus master connected to it.

#### 7.18.5.1 Features

- I<sup>2</sup>C0 is a standard I<sup>2</sup>C compliant bus interface with open-drain pins. I<sup>2</sup>C0 also supports Fast mode plus with bit rates up to 1 Mbit/s.
- I<sup>2</sup>C1 uses standard I/O pins with bit rates of up to 400 kbit/s (Fast I<sup>2</sup>C-bus).
- Easy to configure as master, slave, or master/slave.
- Programmable clocks allow versatile rate control.
- Bidirectional data transfer between masters and slaves.
- Multi-master bus (no central master).
- Arbitration between simultaneously transmitting masters without corruption of serial data on the bus.
- Serial clock synchronization allows devices with different bit rates to communicate via one serial bus.
- Serial clock synchronization can be used as a handshake mechanism to suspend and resume serial transfer.
- The I<sup>2</sup>C-bus can be used for test and diagnostic purposes.
- All I<sup>2</sup>C-bus controllers support multiple address recognition and a bus monitor mode.

#### 7.18.6 I<sup>2</sup>S interface

**Remark:** The LPC43S70 each contain two I<sup>2</sup>S-bus interfaces.

The I<sup>2</sup>S-bus provides a standard communication interface for digital audio applications.

The *I<sup>2</sup>S-bus specification* defines a 3-wire serial bus using one data line, one clock line, and one word select signal. The basic I<sup>2</sup>S-bus connection has one master, which is always the master, and one slave. The I<sup>2</sup>S-bus interface provides a separate transmit and receive channel, each of which can operate as either a master or a slave.

##### 7.18.6.1 Features

- Both I<sup>2</sup>S interfaces have separate input/output channels, each of which can operate in master or slave mode.
- Capable of handling 8-bit, 16-bit, and 32-bit word sizes.
- Mono and stereo audio data supported.
- The sampling frequency can range from 16 kHz to 192 kHz (16, 22.05, 32, 44.1, 48, 96, 192) kHz.
- Support for an audio master clock.
- Configurable word select period in master mode (separately for I<sup>2</sup>S-bus input and output).
- Two 8-word FIFO data buffers are provided, one for transmit and one for receive.
- Generates interrupt requests when buffer levels cross a programmable boundary.
- Two DMA requests for each I<sup>2</sup>S interface, controlled by programmable buffer levels. These are connected to the GPDMA block.

- Controls include reset, stop and mute options separately for I<sup>2</sup>S-bus input and I<sup>2</sup>S-bus output.

### 7.18.7 C\_CAN

**Remark:** The LPC43S70 each contain two C\_CAN controllers. Use of C\_CAN controller excludes operation of all other peripherals connected to the same bus bridge. See [Figure 1](#).

Controller Area Network (CAN) is the definition of a high performance communication protocol for serial data communication. The C\_CAN controller is designed to provide a full implementation of the CAN protocol according to the CAN Specification Version 2.0B. The C\_CAN controller allows to build powerful local networks with low-cost multiplex wiring by supporting distributed real-time control with a very high level of reliability.

#### 7.18.7.1 Features

- Conforms to protocol version 2.0 parts A and B.
- Supports bit rate of up to 1 Mbit/s.
- Supports 32 Message Objects.
- Each Message Object has its own identifier mask.
- Provides programmable FIFO mode (concatenation of Message Objects).
- Provides maskable interrupts.
- Supports Disabled Automatic Retransmission (DAR) mode for time-triggered CAN applications.
- Provides programmable loop-back mode for self-test operation.

## 7.19 Counter/timers and motor control

### 7.19.1 General purpose 32-bit timers/external event counters

The LPC43S70 include four 32-bit timer/counters. The timer/counter is designed to count cycles of the system derived clock or an externally-supplied clock. It can optionally generate interrupts, generate timed DMA requests, or perform other actions at specified timer values, based on four match registers. Each timer/counter also includes two capture inputs to trap the timer value when an input signal transitions, optionally generating an interrupt.

#### 7.19.1.1 Features

- A 32-bit timer/counter with a programmable 32-bit prescaler.
- Counter or timer operation.
- Two 32-bit capture channels per timer, that can take a snapshot of the timer value when an input signal transitions. A capture event may also generate an interrupt.
- Four 32-bit match registers that allow:
  - Continuous operation with optional interrupt generation on match.
  - Stop timer on match with optional interrupt generation.
  - Reset timer on match with optional interrupt generation.

- Up to four external outputs corresponding to match registers, with the following capabilities:
  - Set LOW on match.
  - Set HIGH on match.
  - Toggle on match.
  - Do nothing on match.
- Up to two match registers can be used to generate timed DMA requests.

### 7.19.2 Motor control PWM

The motor control PWM is a specialized PWM supporting 3-phase motors and other combinations. Feedback inputs are provided to automatically sense rotor position and use that information to ramp speed up or down. An abort input is also provided that causes the PWM to immediately release all motor drive outputs. At the same time, the motor control PWM is highly configurable for other generalized timing, counting, capture, and compare applications.

### 7.19.3 Quadrature Encoder Interface (QEI)

A quadrature encoder, also known as a 2-channel incremental encoder, converts angular displacement into two pulse signals. By monitoring both the number of pulses and the relative phase of the two signals, the user can track the position, direction of rotation, and velocity. In addition, a third channel, or index signal, can be used to reset the position counter. The quadrature encoder interface decodes the digital pulses from a quadrature encoder wheel to integrate position over time and determine direction of rotation. In addition, the QEI can capture the velocity of the encoder wheel.

#### 7.19.3.1 Features

- Tracks encoder position.
- Increments/decrements depending on direction.
- Programmable for 2× or 4× position counting.
- Velocity capture using built-in timer.
- Velocity compare function with “less than” interrupt.
- Uses 32-bit registers for position and velocity.
- Three position compare registers with interrupts.
- Index counter for revolution counting.
- Index compare register with interrupts.
- Can combine index and position interrupts to produce an interrupt for whole and partial revolution displacement.
- Digital filter with programmable delays for encoder input signals.
- Can accept decoded signal inputs (clk and direction).

### 7.19.4 Repetitive Interrupt (RI) timer

The repetitive interrupt timer provides a free-running 32-bit counter which is compared to a selectable value, generating an interrupt when a match occurs. Any bits of the timer/compare can be masked such that they do not contribute to the match detection. The repetitive interrupt timer can be used to create an interrupt that repeats at predetermined intervals.

#### 7.19.4.1 Features

- 32-bit counter. Counter can be free-running or be reset by a generated interrupt.
- 32-bit compare value.
- 32-bit compare mask. An interrupt is generated when the counter value equals the compare value, after masking. This allows for combinations not possible with a simple compare.

### 7.19.5 Windowed WatchDog Timer (WWDT)

The purpose of the watchdog is to reset the controller if software fails to periodically service it within a programmable time window.

#### 7.19.5.1 Features

- Internally resets chip if not periodically reloaded during the programmable time-out period.
- Optional windowed operation requires reload to occur between a minimum and maximum time period, both programmable.
- Optional warning interrupt can be generated at a programmable time prior to watchdog time-out.
- Enabled by software but requires a hardware reset or a watchdog reset/interrupt to be disabled.
- Incorrect feed sequence causes reset or interrupt if enabled.
- Flag to indicate watchdog reset.
- Programmable 24-bit timer with internal prescaler.
- Selectable time period from  $(T_{cy(WDCLK)} \times 256 \times 4)$  to  $(T_{cy(WDCLK)} \times 2^{24} \times 4)$  in multiples of  $T_{cy(WDCLK)} \times 4$ .

## 7.20 Analog peripherals

### 7.20.1 12-bit high-speed Analog-to-Digital Converter (ADCHS)

#### 7.20.1.1 Features

- 12-bit high-speed ADC.
- Six single-sided input channels or one differential input channel.
- Descriptor based conversion sequence for single or multiple inputs.
- Integrated 14-bit timer.
- Automatic high/low threshold detection.
- Power-down mode.

- Measurement range of 0 V to 1.2 V.
- 12-bit conversion rate of 80 MSamples/s.
- Conversion on transition on input pin or various internal signals.
- Output FIFO with DMA support.

## 7.20.2 10-bit Analog-to-Digital Converter (ADC0/1)

### 7.20.2.1 Features

- 10-bit successive approximation analog to digital converter.
- Input multiplexing among 8 pins per ADC for a total of 16 individual channels.
- Power-down mode.
- Measurement range 0 to VDDA.
- Sampling frequency up to 400 kSamples/s.
- Burst conversion mode for single or multiple inputs.
- Optional conversion on transition on ADCTRIG0 or ADCTRIG1 pins, combined timer outputs 8 or 15, or the PWM output MCOA2.
- Individual result registers for each A/D channel to reduce interrupt overhead.
- DMA support.

## 7.20.3 Digital-to-Analog Converter (DAC)

### 7.20.3.1 Features

- 10-bit resolution
- Monotonic by design (resistor string architecture)
- Controllable conversion speed
- Low power consumption

## 7.21 Peripherals in the RTC power domain

### 7.21.1 RTC

The Real Time Clock (RTC) is a set of counters for measuring time when system power is on, and optionally when it is off. It uses very little power when its registers are not being accessed by the CPU, especially reduced power modes. The RTC is clocked by a separate 32 kHz oscillator that produces a 1 Hz internal time reference. The RTC is powered by its own power supply pin, VBAT.

#### 7.21.1.1 Features

- Measures the passage of time to maintain a calendar and clock. Provides seconds, minutes, hours, day of month, month, year, day of week, and day of year.
- Ultra-low power design to support battery powered systems. Uses power from the CPU power supply when it is present.
- Dedicated battery power supply pin.
- RTC power supply is isolated from the rest of the chip.
- Calibration counter allows adjustment to better than  $\pm 1$  sec/day with 1 sec resolution.

- Periodic interrupts can be generated from increments of any field of the time registers.
- Alarm interrupt can be generated for a specific date/time.

### 7.21.2 Alarm timer

The alarm timer is a 16-bit timer and counts down at 1 kHz from a preset value generating alarms in intervals of up to 1 min. The counter triggers a status bit when it reaches 0x00 and asserts an interrupt if enabled.

The alarm timer is part of the RTC power domain and can be battery powered.

## 7.22 System control

### 7.22.1 Configuration registers (CREG)

The following settings are controlled in the configuration register block:

- BOD trip settings
- Oscillator output
- DMA-to-peripheral muxing
- Ethernet mode
- Memory mapping
- Timer/USART inputs
- Enabling the USB controllers

In addition, the CREG block contains the part identification and part configuration information.

### 7.22.2 System Control Unit (SCU)

The system control unit determines the function and electrical mode of the digital pins. By default function 0 is selected for all pins with pull-up enabled. For pins that support a digital and analog function, the ADC function select registers in the SCU enable the analog function.

A separate set of analog I/Os for the ADCs and the DAC as well as most USB pins are located on separate pads and are not controlled through the SCU.

In addition, the clock delay register for the SDRAM EMC\_CLK pins and the registers that select the pin interrupts are located in the SCU.

### 7.22.3 Clock Generation Unit (CGU)

The Clock Generator Unit (CGU) generates several base clocks. The CGU outputs are unrelated in frequency and phase and can have different clock sources within the CGU. One CGU output is routed to the CLKOUT pins.

Within each clock area there may be multiple branch clocks, which offers very flexible control for power-management purposes. All branch clocks are outputs of one of two Clock Control Units (CCUs) and can be controlled independently. Branch clocks derived from the same base clock are synchronous in frequency and phase.

#### 7.22.4 Internal RC oscillator (IRC)

The IRC is used as the clock source for the WWDT and/or as the clock that drives the PLLs and subsequently the CPU. The nominal IRC frequency is 12 MHz. The IRC is trimmed to 1 % accuracy over the entire voltage and temperature range.

Upon power-up or any chip reset, the LPC43S70 use the IRC as the clock source. Software may later switch to one of the other available clock sources.

#### 7.22.5 PLL0USB (for USB0)

PLL0 is a dedicated PLL for the USB0 High-speed controller.

PLL0 accepts an input clock frequency from an external oscillator in the range of 14 kHz to 25 MHz. The input frequency is multiplied up to a high frequency with a Current Controlled Oscillator (CCO). The CCO operates in the range of 4.3 MHz to 550 MHz.

#### 7.22.6 PLL0AUDIO (for audio)

The audio PLL PLL0AUDIO is a general purpose PLL with a very small step size. This PLL accepts an input clock frequency derived from an external oscillator or internal IRC. The input frequency is multiplied up to a high frequency with a Current Controlled Oscillator (CCO). A sigma-delta converter modulates the PLL divider ratios to obtain the desired output frequency. The output frequency can be set as a multiple of the sampling frequency  $f_s$  to  $32 \times f_s$ ,  $64 \times f_s$ ,  $128 \times f_s$ ,  $256 \times f_s$ ,  $384 \times f_s$ ,  $512 \times f_s$  and the sampling frequency  $f_s$  can range from 16 kHz to 192 kHz (16, 22.05, 32, 44.1, 48, 96, 192) kHz. Many other frequencies are possible as well.

#### 7.22.7 System PLL1

The PLL1 accepts an input clock frequency from an external oscillator in the range of 1 MHz to 25 MHz. The input frequency is multiplied up to a high frequency with a Current Controlled Oscillator (CCO). The multiplier can be an integer value from 1 to 32. The CCO operates in the range of 156 MHz to 320 MHz, so there is an additional divider in the loop to keep the CCO within its frequency range while the PLL is providing the desired output frequency. The output divider may be set to divide by 2, 4, 8, or 16 to produce the output clock. Since the minimum output divider value is 2, it is insured that the PLL output has a 50 % duty cycle. The PLL is turned off and bypassed following a chip reset and may be enabled by software. The program must configure and activate the PLL, wait for the PLL to lock, and then connect to the PLL as a clock source. The PLL settling time is 100  $\mu$ s.

#### 7.22.8 Reset Generation Unit (RGU)

The RGU allows generation of independent reset signals for individual blocks and peripherals on the LPC43S70.

#### 7.22.9 Power control

The LPC43S70 feature several independent power domains to control power to the core and the peripherals (see [Figure 7](#)). The RTC and its associated peripherals (the alarm timer, the CREG block, the OTP controller, the back-up registers, and the event router) are located in the RTC power-domain which can be powered by a battery supply or the main regulator. A power selector switch ensures that the RTC block is always powered on.

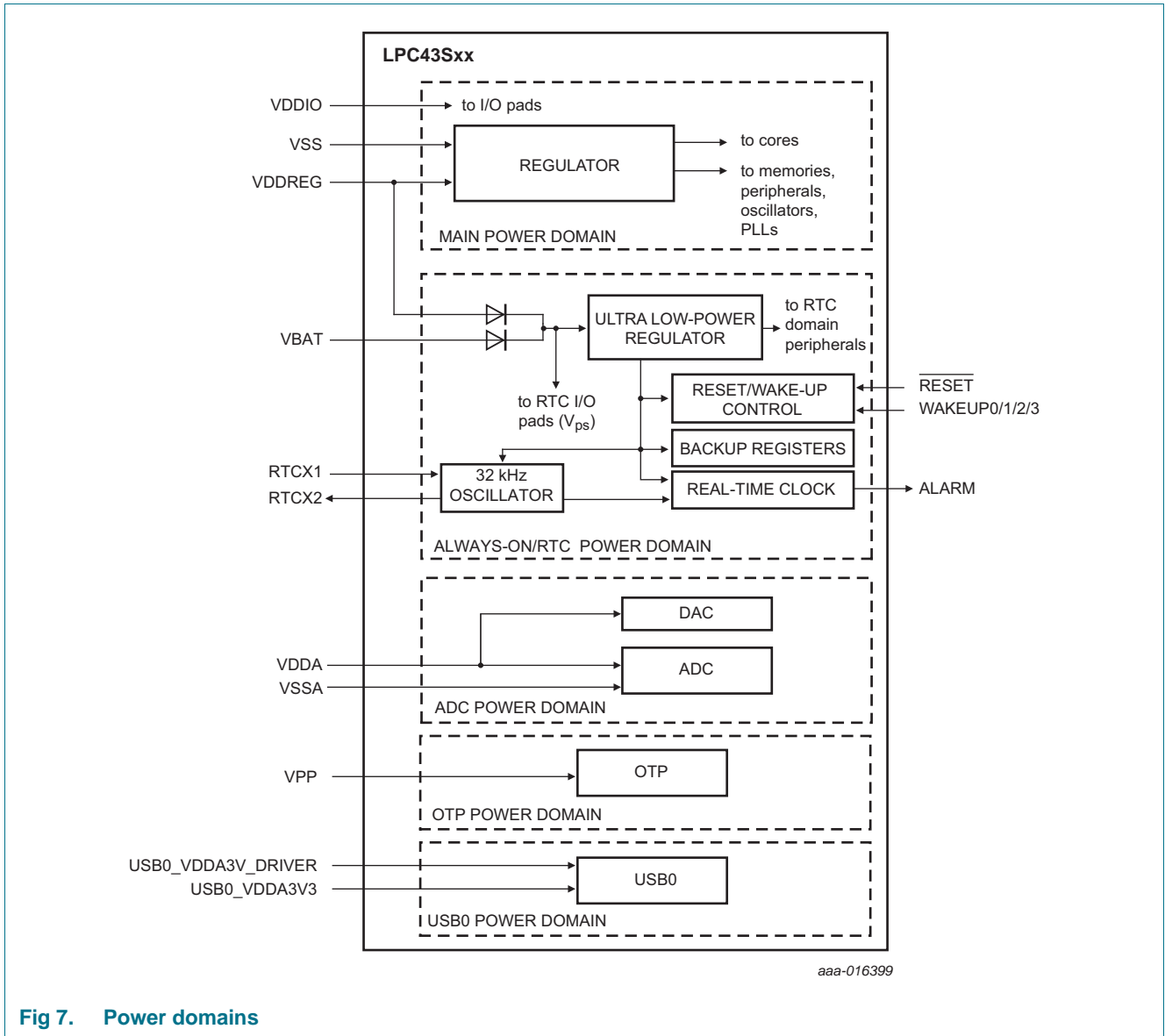

Fig 7. Power domains

7.22.9.1 Memory retention in Power-down modes

Table 6 shows which parts of the SRAM memory are preserved in Sleep mode and the various power-down modes.

In addition, all FIFO memory contained in the peripheral blocks (USB0/1, LCD, CAN, Ethernet, USART0/2/3, UART) is retained in Sleep mode and Deep-sleep mode but not in Power-down mode and Deep-power-down mode.

Table 6. Memory retention

Mode	128 kB local SRAM starting at 0x1000 0000	64 kB Local SRAM starting at 0x1008 0000	8 kB local SRAM starting at 0x1009 0000	16 + 2 kB M0 subsystem SRAM starting at location 0x1800 0000	64 kB AHB SRAM starting at 0x2000 0000	256 byte backup registers at 0x4004 1000 (RTC power domain)
Sleep mode	yes	yes	yes	yes	yes	yes
Deep-sleep mode	yes	yes	yes	yes	yes	yes
Power-down mode	no	no	yes	no	no	yes
Power-down mode with M0SUB SRAM maintained	no	no	yes	yes	no	yes
Deep power-down mode	no	no	no	no	no	yes

### 7.22.9.2 Power Management Controller (PMC)

The PMC controls the power to the cores, peripherals, and memories.

The LPC43S70 support the following power modes in order from highest to lowest power consumption:

1. Active mode
2. Sleep mode
3. Power-down modes:
  - a. Deep-sleep mode
  - b. Power-down mode
  - c. Deep power-down mode

Active mode and sleep mode apply to the state of the core. In a multi-core system, any core can be in active or sleep mode independently of the other core.

If the core is in Active mode, it is fully operational and can access peripherals and memories as configured by software. If the core is in Sleep mode, it receives no clocks, but peripherals and memories can remain running.

Any core can enter sleep mode from active mode independently of the other cores and while the other cores remain in active mode or are in sleep mode.

Power-down modes apply to the entire system. In the Power-down modes, all cores and all peripherals except for peripherals in the always-on power domain are shut down. Memories can remain powered for retaining memory contents as defined by the individual power-down mode.

Any core in active mode can put the part into one of the three power down modes if the core is enabled to do so. If both the M4 core and the two M0 cores are enabled for power-down, then the system enters power-down only once all three cores have received a WFI or WFE instruction.

Wake-up from sleep mode is caused by an interrupt or event in the core's NVIC. An interrupt is captured in the NVIC and an event is captured in the Event router. Both cores can wake up from sleep mode independently of each other.

Wake-up from the Power-down modes, Deep-sleep, Power-down, and Deep power-down, is caused by an event on the WAKEUP pins or an event from the RTC or alarm timer.

When waking up from Deep power-down mode, the part resets and attempts to boot. After booting, the M4 core is in active mode and both M0 cores remain in the reset state until the reset is released by software.

### 7.23 Serial Wire Debug/JTAG

Debug and trace functions are integrated into the ARM Cortex-M4. Serial wire debug and trace functions are supported in addition to a standard JTAG debug and parallel trace functions. The ARM Cortex-M4 is configured to support up to eight breakpoints and four watch points.

The ARM Cortex-M0 coprocessors support JTAG boundary scan only.

## 8. Limiting values

**Table 7. Limiting values**

In accordance with the Absolute Maximum Rating System (IEC 60134).<sup>[1]</sup>

Symbol	Parameter	Conditions	Min	Max	Unit
$V_{DD(REG)(3V3)}$	regulator supply voltage (3.3 V)	on pin VDDREG	-0.5	3.6	V
$V_{DD(IO)}$	input/output supply voltage	on pin VDDIO	-0.5	3.6	V
$V_{DDA(3V3)}$	analog supply voltage (3.3 V)	on pin VDDA	-0.5	3.6	V
$V_{BAT}$	battery supply voltage	on pin VBAT	-0.5	3.6	V
$V_{prog(pf)}$	polyfuse programming voltage	on pin VPP	-0.5	3.6	V
$V_I$	input voltage	only valid when the $V_{DD(IO)} \geq 2.2$ V	<sup>[2]</sup>		
		5 V tolerant I/O pins	-0.5	5.5	V
		ADC/DAC pins and digital I/O pins configured for an analog function	-0.5	$V_{DDA(3V3)}$	V
		USB0 pins USB0_DP; USB0_DM; USB0_VBUS	-0.3	5.25	V
		USB0 pins USB0_ID; USB0_RREF	-0.3	3.6	V
		USB1 pins USB1_DP and USB1_DM	-0.3	5.25	V
$I_{DD}$	supply current	per supply pin	<sup>[3]</sup> -	100	mA
$I_{SS}$	ground current	per ground pin	<sup>[3]</sup> -	100	mA
$I_{latch}$	I/O latch-up current	$-(0.5V_{DD(IO)}) < V_I < (1.5V_{DD(IO)})$ ; $T_j < 125$ °C	-	100	mA
$T_{stg}$	storage temperature		<sup>[4]</sup> -65	+150	°C
$P_{tot(pack)}$	total power dissipation (per package)	based on package heat transfer, not device power consumption	-	1.5	W
$V_{ESD}$	electrostatic discharge voltage	human body model; all pins	<sup>[5]</sup>	+2000	V

[1] The following applies to the limiting values:

- This product includes circuitry designed for the protection of its internal devices from the damaging effects of excessive static charge. Nonetheless, it is suggested that conventional precautions be taken to avoid applying greater than the rated maximum.
- Parameters are valid over operating temperature range unless otherwise specified. All voltages are with respect to  $V_{SS}$  unless otherwise noted.
- The limiting values are stress ratings only and operating the part at these values is not recommended and proper operation is not guaranteed. The conditions for functional operation are specified in [Table 10](#).

[2] Including voltage on outputs in 3-state mode.

[3] The peak current is limited to 25 times the corresponding maximum current.

[4] Dependent on package type.

[5] Human body model: equivalent to discharging a 100 pF capacitor through a 1.5 k $\Omega$  series resistor.

## 9. Thermal characteristics

The average chip junction temperature,  $T_j$  (°C), can be calculated using the following equation:

$$T_j = T_{amb} + (P_D \times R_{th(j-a)}) \quad (1)$$

- $T_{amb}$  = ambient temperature (°C),
- $R_{th(j-a)}$  = the package junction-to-ambient thermal resistance (°C/W)
- $P_D$  = sum of internal and I/O power dissipation

The internal power dissipation is the product of  $I_{DD}$  and  $V_{DD}$ . The I/O power dissipation of the I/O pins is often small and many times can be negligible. However it can be significant in some applications.

**Table 8. Thermal characteristics**

$V_{DD} = 2.2\text{ V to }3.6\text{ V}$ ;  $T_{amb} = -40\text{ °C to }+85\text{ °C}$  unless otherwise specified;

Symbol	Parameter	Conditions	Min	Typ	Max	Unit
$T_{j(max)}$	maximum junction temperature		-	-	125	°C

**Table 9. Thermal resistance value (BGA package)**

Symbol	Parameter	Conditions	Thermal resistance in °C/W ±15 %	
			LBGA256	TFBGA100
$R_{th(j-a)}$	thermal resistance from junction to ambient	JEDEC (4.5 in × 4 in); still air	29	46
		8-layer (4.5 in × 3 in); still air	24	37
$R_{th(j-c)}$	thermal resistance from junction to case		14	11

## 10. Static characteristics

**Table 10. Static characteristics**

$T_{amb} = -40\text{ }^{\circ}\text{C}$  to  $+85\text{ }^{\circ}\text{C}$ , unless otherwise specified.

Symbol	Parameter	Conditions	Min	Typ <sup>[1]</sup>	Max	Unit
<b>Supply pins</b>						
$V_{DD(I/O)}$	input/output supply voltage		2.2	-	3.6	V
$V_{DD(REG)(3V3)}$	regulator supply voltage (3.3 V)		[2] 2.2	-	3.6	V
$V_{DDA(3V3)}$	analog supply voltage (3.3 V)	on pin VDDA	2.2	-	3.6	V
		on pins USB0_VDDA3V3_DRIVER and USB0_VDDA3V3	3.0	3.3	3.6	V
$V_{BAT}$	battery supply voltage		[2] 2.2	-	3.6	V
$V_{prog(pf)}$	polyfuse programming voltage	on pin VPP (for OTP)	[3] 2.7	-	3.6	V
$I_{prog(pf)}$	polyfuse programming current	on pin VPP; OTP programming time $\leq$ 1.6 ms	-	-	30	mA
$I_{DD(REG)(3V3)}$	regulator supply current (3.3 V)	Active mode; M0 cores in reset; code <code>while(1){}</code> executed from RAM; all peripherals disabled; PLL1 enabled				
		CCLK = 12 MHz	[4] -	6.6	-	mA
		CCLK = 60 MHz	[4] -	25.3	-	mA
		CCLK = 120 MHz	[4] -	48.4	-	mA
		CCLK = 180 MHz	[4] -	72.0	-	mA
		CCLK = 204 MHz	[4] -	81.5	-	mA
$I_{DD(REG)(3V3)}$	regulator supply current (3.3 V)	after WFE/WFI instruction executed from RAM; all peripherals disabled; M0 cores in reset				
		sleep mode	[4][5] -	5.0	-	mA
		deep-sleep mode	[4] -	30	-	$\mu$ A
		power-down mode	[4] -	15	-	$\mu$ A
		power-down mode with M0SUB SRAM retained	[4] -	20	-	$\mu$ A
		deep power-down mode	[4][6] -	0.03	-	$\mu$ A
	deep power-down mode; VBAT floating	[4] -	2	-	$\mu$ A	
$I_{BAT}$	battery supply current	active mode; $V_{BAT} = 3.2\text{ V}$ ; $V_{DD(REG)(3V3)} = 3.6\text{ V}$ .	[7] -	0	-	nA

**Table 10. Static characteristics ...continued** $T_{amb} = -40\text{ }^{\circ}\text{C}$  to  $+85\text{ }^{\circ}\text{C}$ , unless otherwise specified.

Symbol	Parameter	Conditions	Min	Typ <sup>[1]</sup>	Max	Unit
$I_{BAT}$	battery supply current	$V_{DD(REG)(3V3)} = 3.3\text{ V}$ ; $V_{BAT} = 3.6\text{ V}$	[8]			
		deep-sleep mode	-	2	-	$\mu\text{A}$
		power-down mode	[8]	-	2	-
$I_{DD(IO)}$	I/O supply current	deep sleep mode	-	1	-	$\mu\text{A}$
		power-down mode	-	1	-	$\mu\text{A}$
		deep power-down mode	[9]	-	0.05	-
$I_{DDA}$	Analog supply current	on pin VDDA;	[11]	-	0.4	-
		deep sleep mode				$\mu\text{A}$
		power-down mode	[11]	-	0.4	-
$I_{DDA}$	Analog supply current	deep power-down mode	[11]	-	0.007	-
						$\mu\text{A}$

**RESET, RTC\_ALARM, WAKEUPn pins**

$V_{IH}$	HIGH-level input voltage	[10]	$0.8 \times (V_{ps} - 0.35)$	-	5.5	V
$V_{IL}$	LOW-level input voltage	[10]	0	-	$0.3 \times (V_{ps} - 0.1)$	V
$V_{hys}$	hysteresis voltage	[10]	$0.05 \times (V_{ps} - 0.35)$	-	-	V
$V_o$	output voltage	[10]	-	$V_{ps} - 0.2$	-	V

**Standard I/O pins - normal drive strength**

$C_I$	input capacitance		-	-	5.2	pF
$I_{LL}$	LOW-level leakage current	$V_I = 0\text{ V}$ ; on-chip pull-up resistor disabled	-	3	-	nA
$I_{LH}$	HIGH-level leakage current	$V_I = V_{DD(IO)}$ ; on-chip pull-down resistor disabled	-	3	-	nA
		$V_I = 5\text{ V}$	-	-	20	nA
$I_{OZ}$	OFF-state output current	$V_O = 0\text{ V}$ to $V_{DD(IO)}$ ; on-chip pull-up/down resistors disabled; absolute value	-	3	-	nA
$V_I$	input voltage	pin configured to provide a digital function; $V_{DD(IO)} \geq 2.2\text{ V}$	0	-	5.5	V
		$V_{DD(IO)} = 0\text{ V}$	0	-	3.6	V
$V_O$	output voltage	output active	0	-	$V_{DD(IO)}$	V
$V_{IH}$	HIGH-level input voltage		$0.7 \times V_{DD(IO)}$	-	5.5	V
$V_{IL}$	LOW-level input voltage		0	-	$0.3 \times V_{DD(IO)}$	V
$V_{hys}$	hysteresis voltage		$0.1 \times V_{DD(IO)}$	-	-	V

**Table 10. Static characteristics ...continued** $T_{amb} = -40\text{ }^{\circ}\text{C}$  to  $+85\text{ }^{\circ}\text{C}$ , unless otherwise specified.

Symbol	Parameter	Conditions	Min	Typ <sup>[1]</sup>	Max	Unit
$V_{OH}$	HIGH-level output voltage	$I_{OH} = -6\text{ mA}$	$V_{DD(IO)} - 0.4$	-	-	V
$V_{OL}$	LOW-level output voltage	$I_{OL} = 6\text{ mA}$	-	-	0.4	V
$I_{OH}$	HIGH-level output current	$V_{OH} = V_{DD(IO)} - 0.4\text{ V}$	-6	-	-	mA
$I_{OL}$	LOW-level output current	$V_{OL} = 0.4\text{ V}$	6	-	-	mA
$I_{OHS}$	HIGH-level short-circuit output current	drive HIGH; connected to ground	[12] -	-	86.5	mA
$I_{OLS}$	LOW-level short-circuit output current	drive LOW; connected to $V_{DD(IO)}$	[12] -	-	76.5	mA
$I_{pd}$	pull-down current	$V_I = 5\text{ V}$	[14] - [15] [16]	93	-	$\mu\text{A}$
$I_{pu}$	pull-up current	$V_I = 0\text{ V}$	[14] - [15] [16]	-62	-	$\mu\text{A}$
		$V_{DD(IO)} < V_I \leq 5\text{ V}$	-	10	-	$\mu\text{A}$
$R_s$	series resistance	on I/O pins with analog function; analog function enabled		200		$\Omega$
<b>I/O pins - high drive strength</b>						
$C_I$	input capacitance		-	-	2	pF
$I_{LL}$	LOW-level leakage current	$V_I = 0\text{ V}$ ; on-chip pull-up resistor disabled	-	3	-	nA
$I_{LH}$	HIGH-level leakage current	$V_I = V_{DD(IO)}$ ; on-chip pull-down resistor disabled	-	3	-	nA
		$V_I = 5\text{ V}$	-	-	20	nA
$I_{OZ}$	OFF-state output current	$V_O = 0\text{ V}$ to $V_{DD(IO)}$ ; on-chip pull-up/down resistors disabled; absolute value	-	3	-	nA
$V_I$	input voltage	pin configured to provide a digital function;				
		$V_{DD(IO)} \geq 2.2\text{ V}$	0	-	5.5	V
		$V_{DD(IO)} = 0\text{ V}$	0	-	3.6	V
$V_O$	output voltage	output active	0	-	$V_{DD(IO)}$	V
$V_{IH}$	HIGH-level input voltage		$0.7 \times V_{DD(IO)}$	-	5.5	V
$V_{IL}$	LOW-level input voltage		0	-	$0.3 \times V_{DD(IO)}$	V
$V_{hys}$	hysteresis voltage		$0.1 \times V_{DD(IO)}$	-	-	V

**Table 10. Static characteristics ...continued**  
 $T_{amb} = -40\text{ }^{\circ}\text{C}$  to  $+85\text{ }^{\circ}\text{C}$ , unless otherwise specified.

Symbol	Parameter	Conditions	Min	Typ <sup>[1]</sup>	Max	Unit
$I_{pd}$	pull-down current	$V_I = V_{DD(I/O)}$	[14] [15] [16]	62	-	$\mu\text{A}$
$I_{pu}$	pull-up current	$V_I = 0\text{ V}$	[14] [15] [16]	-62	-	$\mu\text{A}$
		$V_{DD(I/O)} < V_I \leq 5\text{ V}$	-	10	-	$\mu\text{A}$
<b>I/O pins - high drive strength: standard drive mode</b>						
$I_{OH}$	HIGH-level output current	$V_{OH} = V_{DD(I/O)} - 0.4\text{ V}$	-4	-	-	mA
$I_{OL}$	LOW-level output current	$V_{OL} = 0.4\text{ V}$	4	-	-	mA
$I_{OHS}$	HIGH-level short-circuit output current	drive HIGH; connected to ground	[12]	-	32	mA
$I_{OLS}$	LOW-level short-circuit output current	drive LOW; connected to $V_{DD(I/O)}$	[12]	-	32	mA
<b>I/O pins - high drive strength: medium drive mode</b>						
$I_{OH}$	HIGH-level output current	$V_{OH} = V_{DD(I/O)} - 0.4\text{ V}$	-8	-	-	mA
$I_{OL}$	LOW-level output current	$V_{OL} = 0.4\text{ V}$	8	-	-	mA
$I_{OHS}$	HIGH-level short-circuit output current	drive HIGH; connected to ground	[12]	-	65	mA
$I_{OLS}$	LOW-level short-circuit output current	drive LOW; connected to $V_{DD(I/O)}$	[12]	-	63	mA
<b>I/O pins - high drive strength: high drive mode</b>						
$I_{OH}$	HIGH-level output current	$V_{OH} = V_{DD(I/O)} - 0.4\text{ V}$	-14	-	-	mA
$I_{OL}$	LOW-level output current	$V_{OL} = 0.4\text{ V}$	14	-	-	mA
$I_{OHS}$	HIGH-level short-circuit output current	drive HIGH; connected to ground	[12]	-	113	mA
$I_{OLS}$	LOW-level short-circuit output current	drive LOW; connected to $V_{DD(I/O)}$	[12]	-	110	mA
<b>I/O pins - high drive strength: ultra-high drive mode</b>						
$I_{OH}$	HIGH-level output current	$V_{OH} = V_{DD(I/O)} - 0.4\text{ V}$	-20	-	-	mA
$I_{OL}$	LOW-level output current	$V_{OL} = 0.4\text{ V}$	20	-	-	mA
$I_{OHS}$	HIGH-level short-circuit output current	drive HIGH; connected to ground	[12]	-	165	mA
$I_{OLS}$	LOW-level short-circuit output current	drive LOW; connected to $V_{DD(I/O)}$	[12]	-	156	mA
<b>I/O pins - high-speed</b>						
$C_I$	input capacitance		-	-	2	pF

**Table 10. Static characteristics ...continued**  
*T<sub>amb</sub> = -40 °C to +85 °C, unless otherwise specified.*

Symbol	Parameter	Conditions	Min	Typ <sup>[1]</sup>	Max	Unit
I <sub>LL</sub>	LOW-level leakage current	V <sub>I</sub> = 0 V; on-chip pull-up resistor disabled	-	3	-	nA
I <sub>LH</sub>	HIGH-level leakage current	V <sub>I</sub> = V <sub>DD(I/O)</sub> ; on-chip pull-down resistor disabled	-	3	-	nA
		V <sub>I</sub> = 5 V	-	-	20	nA
I <sub>OZ</sub>	OFF-state output current	V <sub>O</sub> = 0 V to V <sub>DD(I/O)</sub> ; on-chip pull-up/down resistors disabled; absolute value	-	3	-	nA
V <sub>I</sub>	input voltage	pin configured to provide a digital function;				
		V <sub>DD(I/O)</sub> ≥ 2.2 V	0	-	5.5	V
		V <sub>DD(I/O)</sub> = 0 V	0	-	3.6	V
V <sub>O</sub>	output voltage	output active	0	-	V <sub>DD(I/O)</sub>	V
V <sub>IH</sub>	HIGH-level input voltage		0.7 × V <sub>DD(I/O)</sub>	-	5.5	V
V <sub>IL</sub>	LOW-level input voltage		0	-	0.3 × V <sub>DD(I/O)</sub>	V
V <sub>hys</sub>	hysteresis voltage		0.1 × V <sub>DD(I/O)</sub>	-	-	V
V <sub>OH</sub>	HIGH-level output voltage	I <sub>OH</sub> = -8 mA	V <sub>DD(I/O)</sub> - 0.4	-	-	V
V <sub>OL</sub>	LOW-level output voltage	I <sub>OL</sub> = 8 mA	-	-	0.4	V
I <sub>OH</sub>	HIGH-level output current	V <sub>OH</sub> = V <sub>DD(I/O)</sub> - 0.4 V	-8	-	-	mA
I <sub>OL</sub>	LOW-level output current	V <sub>OL</sub> = 0.4 V	8	-	-	mA
I <sub>OHS</sub>	HIGH-level short-circuit output current	drive HIGH; connected to ground	[12] -	-	86	mA
I <sub>OLS</sub>	LOW-level short-circuit output current	drive LOW; connected to V <sub>DD(I/O)</sub>	[12] -	-	76	mA
I <sub>pd</sub>	pull-down current	V <sub>I</sub> = V <sub>DD(I/O)</sub>	[14] - [15] [16]	62	-	μA
I <sub>pu</sub>	pull-up current	V <sub>I</sub> = 0 V	[14] - [15] [16]	-62	-	μA
		V <sub>DD(I/O)</sub> < V <sub>I</sub> ≤ 5 V	-	0	-	μA
<b>Open-drain I<sup>2</sup>C0-bus pins</b>						
V <sub>IH</sub>	HIGH-level input voltage		0.7 × V <sub>DD(I/O)</sub>	-	-	V
V <sub>IL</sub>	LOW-level input voltage		0	0.14	0.3 × V <sub>DD(I/O)</sub>	V

**Table 10. Static characteristics ...continued**  
*T<sub>amb</sub> = -40 °C to +85 °C, unless otherwise specified.*

Symbol	Parameter	Conditions	Min	Typ <sup>[1]</sup>	Max	Unit
V <sub>hys</sub>	hysteresis voltage		0.1 × V <sub>DD(I/O)</sub>	-	-	V
V <sub>OL</sub>	LOW-level output voltage	I <sub>OLS</sub> = 3 mA	-	-	0.4	V
I <sub>LI</sub>	input leakage current	V <sub>I</sub> = V <sub>DD(I/O)</sub>	[13]	-	4.5	μA
		V <sub>I</sub> = 5 V	-	-	10	μA
<b>Oscillator pins</b>						
V <sub>i(XTAL1)</sub>	input voltage on pin XTAL1		-0.5	-	1.2	V
V <sub>o(XTAL2)</sub>	output voltage on pin XTAL2		-0.5	-	1.2	V
C <sub>io</sub>	input/output capacitance		[17]	-	0.8	pF
<b>USB0 pins<sup>[18]</sup></b>						
V <sub>I</sub>	input voltage	on pins USB0_DP; USB0_DM; USB0_VBUS				
		V <sub>DD(I/O)</sub> ≥ 2.2 V	0	-	5.25	V
		V <sub>DD(I/O)</sub> = 0 V	0	-	3.6	V
R <sub>pd</sub>	pull-down resistance	on pin USB0_VBUS	48	64	80	kΩ
V <sub>IC</sub>	common-mode input voltage	high-speed mode	-50	200	500	mV
		full-speed/low-speed mode	800	-	2500	mV
		chirp mode	-50	-	600	mV
V <sub>i(dif)</sub>	differential input voltage		100	400	1100	mV
<b>USB1 pins (USB1_DP/USB1_DM)<sup>[18]</sup></b>						
I <sub>oz</sub>	OFF-state output current	0 V < V <sub>I</sub> < 3.3 V	[18]	-	±10	μA
V <sub>BUS</sub>	bus supply voltage		[19]	-	5.25	V
V <sub>DI</sub>	differential input sensitivity voltage	(D+) - (D-)	0.2	-	-	V
V <sub>CM</sub>	differential common mode voltage range	includes V <sub>DI</sub> range	0.8	-	2.5	V
V <sub>th(rs)se</sub>	single-ended receiver switching threshold voltage		0.8	-	2.0	V
V <sub>OL</sub>	LOW-level output voltage for low-/full-speed	R <sub>L</sub> of 1.5 kΩ to 3.6 V	-	-	0.18	V

**Table 10. Static characteristics ...continued**  
 $T_{amb} = -40\text{ }^{\circ}\text{C}$  to  $+85\text{ }^{\circ}\text{C}$ , unless otherwise specified.

Symbol	Parameter	Conditions	Min	Typ <sup>[1]</sup>	Max	Unit
$V_{OH}$	HIGH-level output voltage (driven) for low-/full-speed	$R_L$ of 15 k $\Omega$ to GND	2.8	-	3.5	V
$C_{trans}$	transceiver capacitance	pin to GND	-	-	20	pF
$Z_{DRV}$	driver output impedance for driver which is not high-speed capable	with 33 $\Omega$ series resistor; steady state drive	[20] 36	-	44.1	$\Omega$

- [1] Typical ratings are not guaranteed. The values listed are at room temperature (25  $^{\circ}\text{C}$ ), nominal supply voltages.
- [2] The recommended operating condition for the battery supply is  $V_{DD(REG)(3V3)} > V_{BAT} + 0.2\text{ V}$ . See [Figure 15](#).
- [3] Pin VPP should either be not connected (when OTP does not need to be programmed) or tied to pins VDDIO and VDDREG to ensure the same ramp-up time for both supply voltages.
- [4]  $V_{DD(REG)(3V3)} = 3.3\text{ V}$ ;  $V_{DD(IO)} = 3.3\text{ V}$ ;  $T_{amb} = 25\text{ }^{\circ}\text{C}$ .
- [5] PLL1 disabled; IRC running; CCLK = 12 MHz.
- [6]  $V_{BAT} = 3.6\text{ V}$ .
- [7]  $V_{DD(IO)} = V_{DDA} = 3.6\text{ V}$ ; over entire frequency range CCLK = 12 MHz to 180 MHz.
- [8] On pin VBAT;  $T_{amb} = 25\text{ }^{\circ}\text{C}$ .
- [9]  $V_{DD(REG)(3V3)} = 3.3\text{ V}$ ;  $V_{DD(IO)} = 3.3\text{ V}$ . Input leakage increases when  $V_{DD(IO)}$  is floating or grounded. It is recommended to keep  $V_{DD(REG)(3V3)}$  and  $V_{DD(IO)}$  powered in deep power-down mode.
- [10]  $V_{ps}$  corresponds to the output of the power switch (see [Figure 7](#)) which is determined by the greater of  $V_{BAT}$  and  $V_{DD(Reg)(3V3)}$ .
- [11]  $V_{DDA(3V3)} = 3.3\text{ V}$ ;  $T_{amb} = 25\text{ }^{\circ}\text{C}$ .
- [12] Allowed as long as the current limit does not exceed the maximum current allowed by the device.
- [13] To  $V_{SS}$ .
- [14] The values specified are simulated and absolute values.
- [15] The weak pull-up resistor is connected to the  $V_{DD(IO)}$  rail and pulls up the I/O pin to the  $V_{DD(IO)}$  level.
- [16] The input cell disables the weak pull-up resistor when the applied input voltage exceeds  $V_{DD(IO)}$ .
- [17] The parameter value specified is a simulated value excluding bond capacitance.
- [18] For USB operation  $3.0\text{ V} \leq V_{DD(IO)} \leq 3.6\text{ V}$ . Guaranteed by design.
- [19]  $V_{DD(IO)}$  present.
- [20] Includes external resistors of  $33\text{ }\Omega \pm 1\%$  on D+ and D-.

10.1 Power consumption

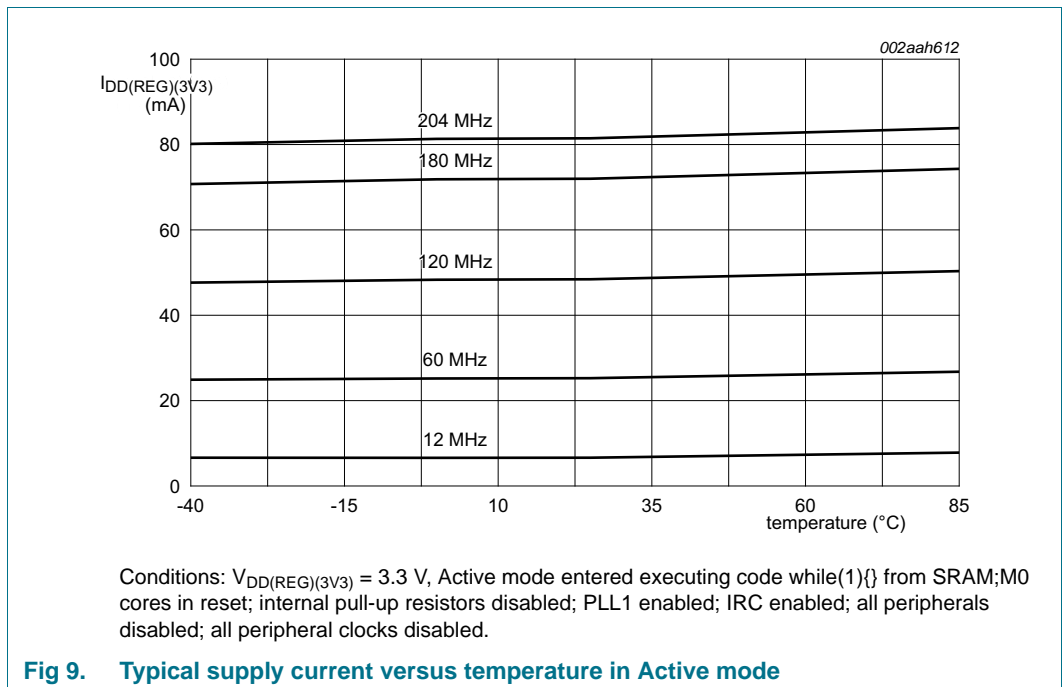
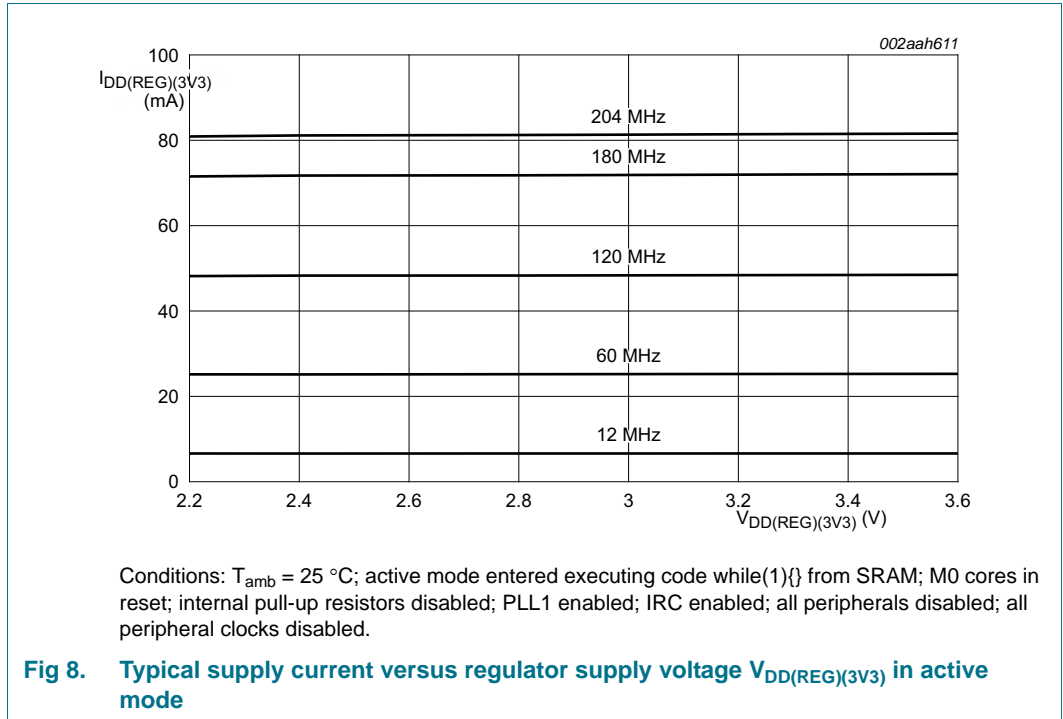

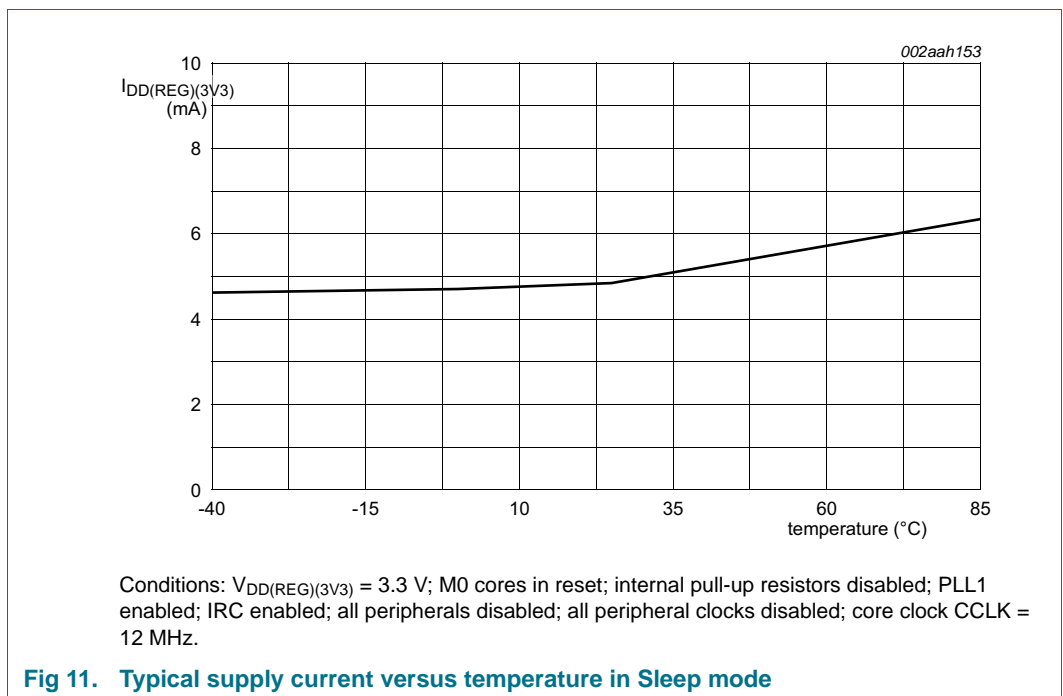
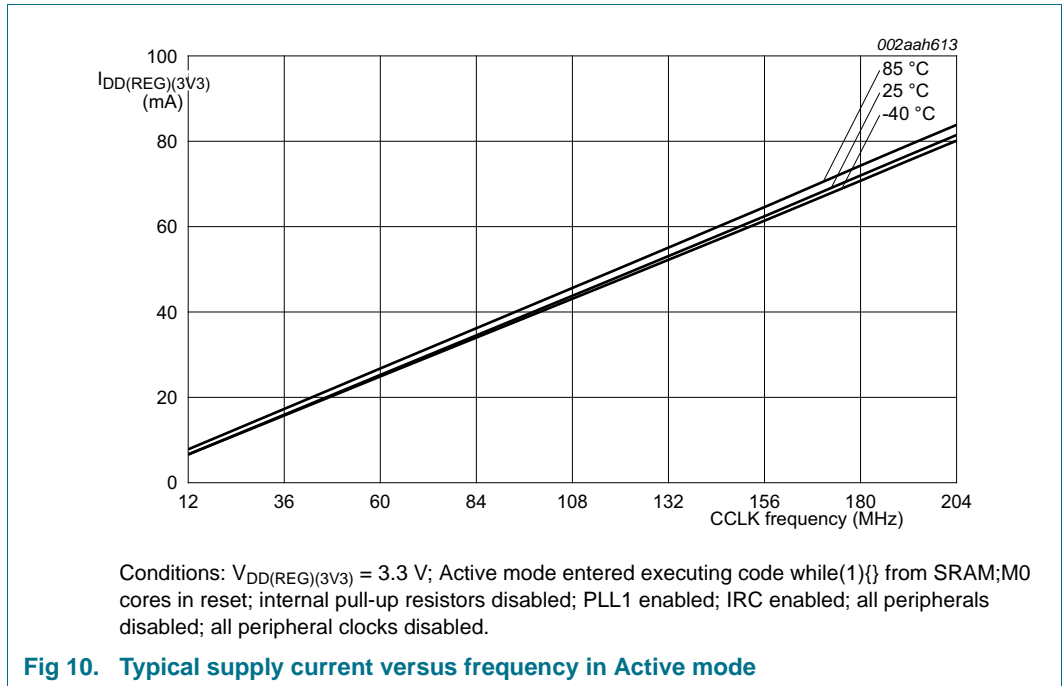

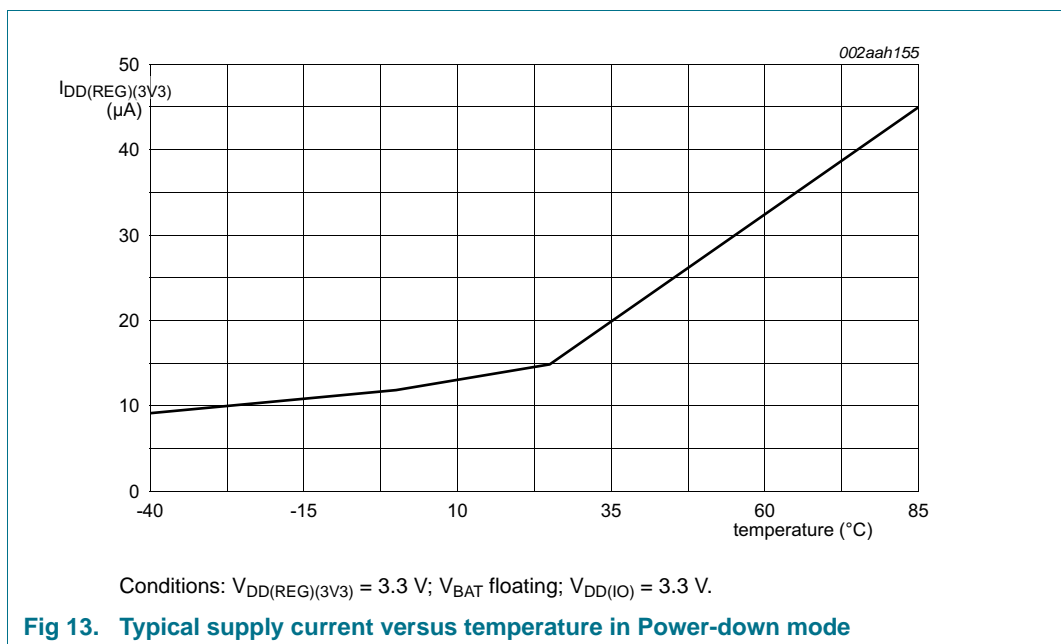
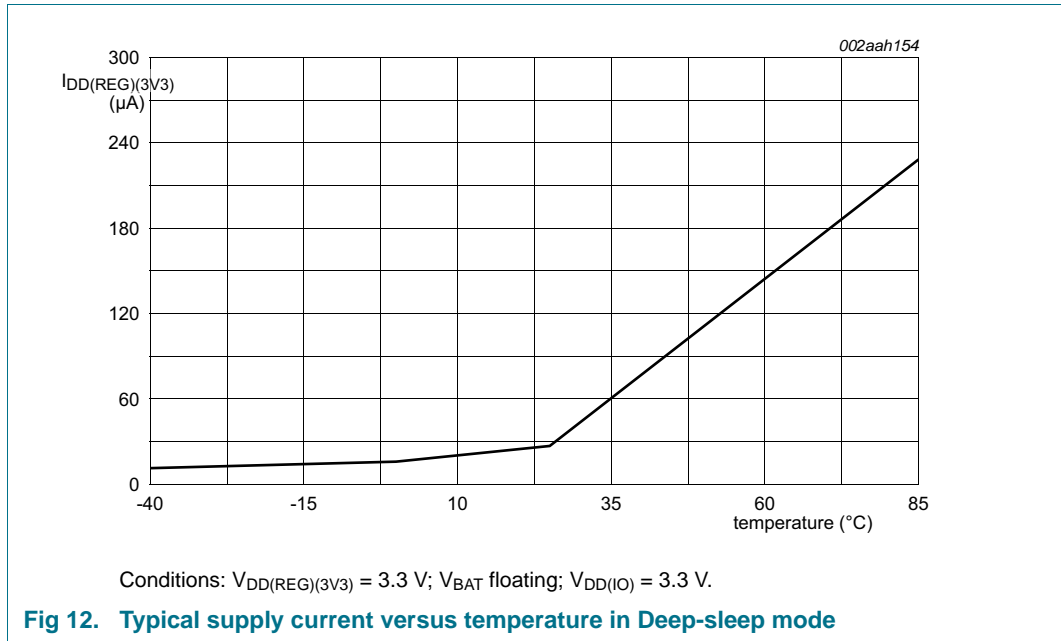

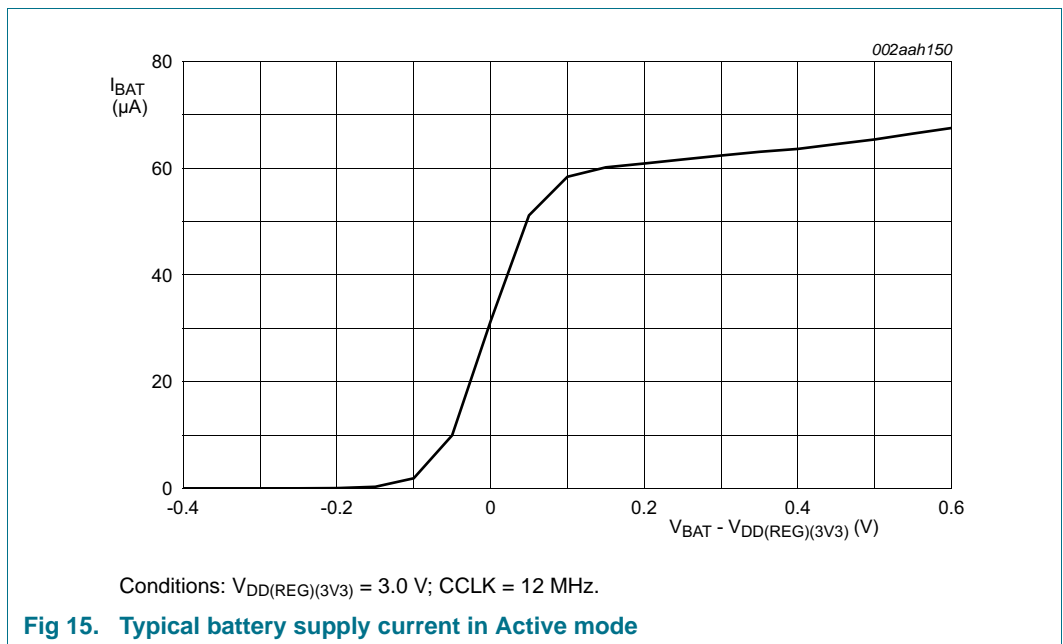
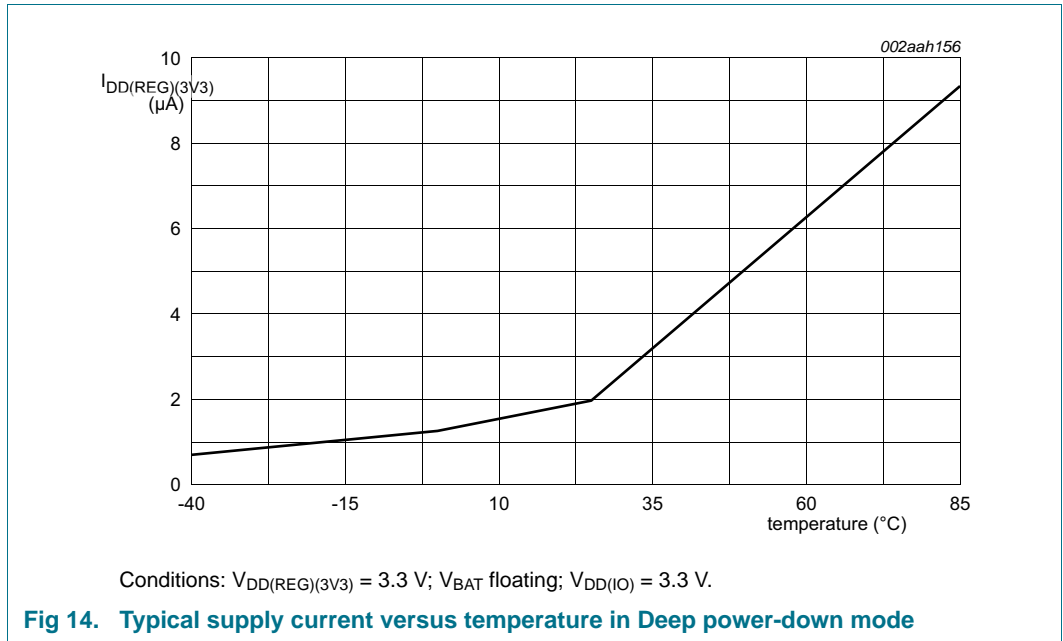

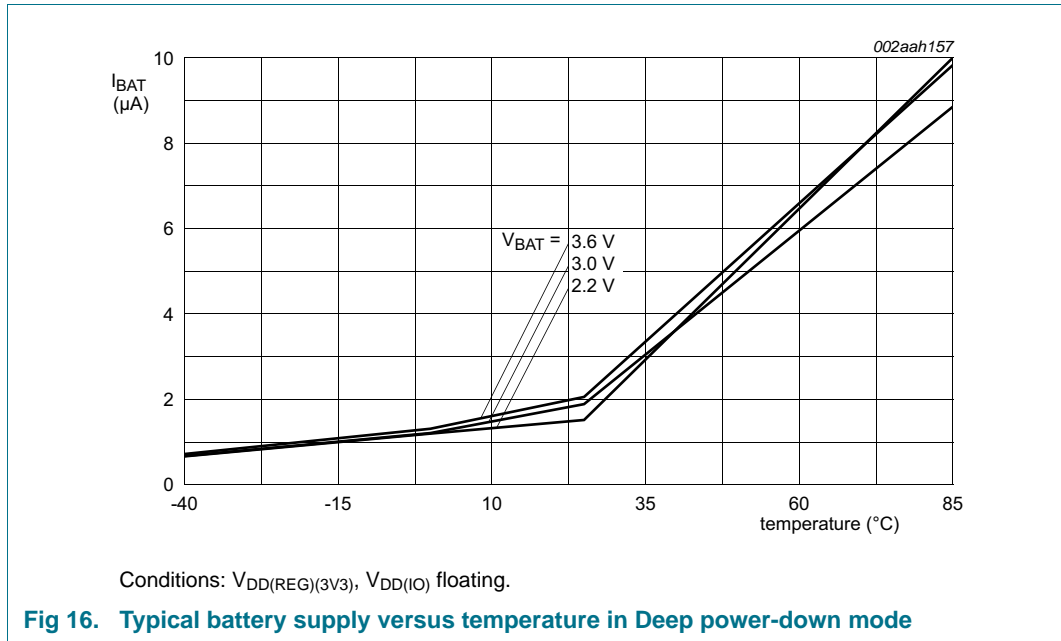

## 10.2 Peripheral power consumption

The typical power consumption at  $T = 25\text{ }^{\circ}\text{C}$  for each individual peripheral is measured as follows:

1. Enable all branch clocks and measure the current  $I_{DD(REG)(3V3)}$ .
2. Disable the branch clock to the peripheral to be measured and keep all other branch clocks enabled.
3. Calculate the difference between measurement 1 and 2. The result is the peripheral power consumption.

**Table 11. Peripheral power consumption**

Peripheral	Branch clock	$I_{DD(REG)(3V3)}$ in mA	
		Branch clock frequency = 48 MHz	Branch clock frequency = 96 MHz
M0 subsystem core	CLK_PERIPH_CORE	2.4	4.8
M0 coprocessor	CLK_M4_M0APP	3.3	6.6
I2C1	CLK_APB3_I2C1	0.01	0.02
I2C0	CLK_APB1_I2C0	0.02	0.01
DAC	CLK_APB3_DAC	0.01	0.02
ADC0 (10-bit)	CLK_APB3_ADC0	0.05	0.05
ADC1 (10-bit)	CLK_APB3_ADC1	0.04	0.04
CAN0	CLK_APB3_CAN0	0.17	0.17
CAN1	CLK_APB1_CAN1	0.17	0.17
MOTOCON	CLK_APB1_MOTOCON	0.05	0.05
I2S	CLK_APB1_I2S	0.11	0.11
SPIFI	CLK_SPIFI, CLK_M4_SPIFI	0.95	1.85

Table 11. Peripheral power consumption

Peripheral	Branch clock	I <sub>DD(REG)(3V3)</sub> in mA	
		Branch clock frequency = 48 MHz	Branch clock frequency = 96 MHz
GPIO	CLK_M4_GPIO	0.66	1.31
LCD	CLK_M4_LCD	0.85	1.72
ETHERNET	CLK_M4_ETHERNET	1.05	2.09
UART0	CLK_M4_UART0, CLK_APB0_UART0	0.3	0.38
UART1	CLK_M4_UART1, CLK_APB0_UART1	0.27	0.48
UART2	CLK_M4_UART2, CLK_APB2_UART2	0.27	0.47
UART3	CLK_M4_USART3, CLK_APB2_UART3	0.29	0.49
TIMER0	CLK_M4_TIMER0	0.07	0.14
TIMER1	CLK_M4_TIMER1	0.07	0.14
TIMER2	CLK_M4_TIMER2	0.07	0.15
TIMER3	CLK_M4_TIMER3	0.06	0.11
SDIO	CLK_M4_SDIO, CLK_SDIO	0.79	1.37
SCT	CLK_M4_SCT	0.52	1.05
SSP0	CLK_M4_SSP0, CLK_APB0_SSP0	0.12	0.21
SSP1	CLK_M4_SSP1, CLK_APB2_SSP1	0.15	0.28
DMA	CLK_M4_DMA	1.88	3.71
WWDT	CLK_M4_WWDT	0.05	0.08
QEI	CLK_M4_QEI	0.33	0.68
USB0	CLK_M4_USB0, CLK_USB0	1.46	3.32
USB1	CLK_M4_USB1, CLK_USB1	2.83	5.03
RITIMER	CLK_M4_RITIMER	0.04	0.08
EMC	CLK_M4_EMCC, CLK_M4_EMCC_DIV	3.6	6.97
SCU	CLK_M4_SCU	0.09	0.23
CREG	CLK_M4_CREG	0.37	0.72
SGPIO	CLK_PERIPH_SGPIO	0.1	0.17
SPI	CLK_SPI	0.07	0.11

Table 12. Peripheral power consumption 12-bit ADCHS

Peripheral	Branch clock	I <sub>DD(REG)(3V3)</sub> in mA		Conditions
		Branch clock frequency = 39 MHz	Branch clock frequency = 78 MHz	
ADCHS (12-bit ADC)	CLK_ADCHS, CLK_M4_ADCH	1.1	2.3	Peripheral power consumption; no ADC conversions
ADCHS (12-bit ADC)	CLK_ADCHS, CLK_M4_ADCH	28.5	41.6	Peripheral power consumption; ADC converting samples at CLK_ADCHS frequency

### 10.3 BOD and band gap static characteristics

Table 13. BOD static characteristics<sup>[1]</sup>

$T_{amb} = 25\text{ }^{\circ}\text{C}$ ; simulated values for nominal processing.

Symbol	Parameter	Conditions	Min	Typ	Max	Unit	
V <sub>th</sub>	threshold voltage	interrupt level 0					
		assertion	-	2.75	-	V	
		de-assertion	-	2.92	-	V	
		interrupt level 1					
		assertion	-	2.85	-	V	
		de-assertion	-	3.00	-	V	
		interrupt level 2					
		assertion	-	2.95	-	V	
		de-assertion	-	3.12	-	V	
		interrupt level 3					
		assertion	-	3.05	-	V	
		de-assertion	-	3.19	-	V	
		reset level 0					
		assertion	-	1.70	-	V	
		de-assertion	-	1.85	-	V	
		reset level 1					
		assertion	-	1.80	-	V	
		de-assertion	-	1.95	-	V	
		reset level 2					
		assertion	-	1.90	-	V	
		de-assertion	-	2.05	-	V	
		reset level 3					
		assertion	-	2.00	-	V	
		de-assertion	-	2.15	-	V	

[1] Interrupt and reset levels are selected by writing to the BODLV1/2 bits in the control register CREGE0, see the LPC43xx user manual.

**Table 14. Band gap characteristics**

$V_{DDA(3V3)}$  over specified ranges;  $T_{amb} = -40\text{ }^{\circ}\text{C}$  to  $+85\text{ }^{\circ}\text{C}$ ; unless otherwise specified

Symbol	Parameter		Min	Typ	Max	Unit
$V_{ref(bg)}$	band gap reference voltage	[1]	0.621	0.6425	0.664	V

[1] Based on characterization, not tested in production.

10.4 Electrical pin characteristics

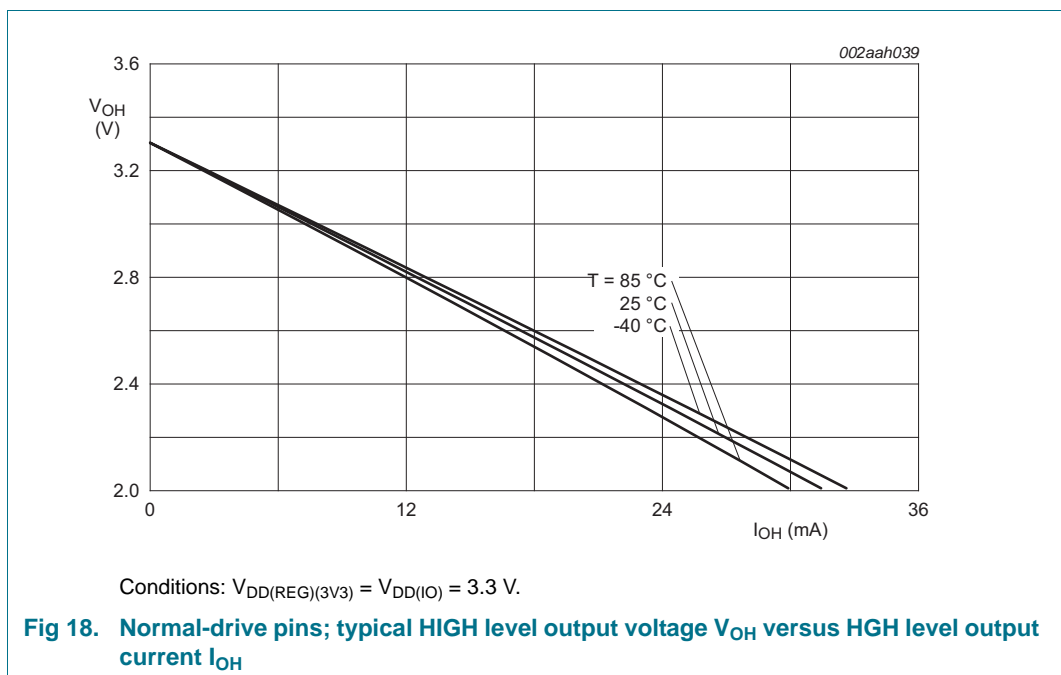
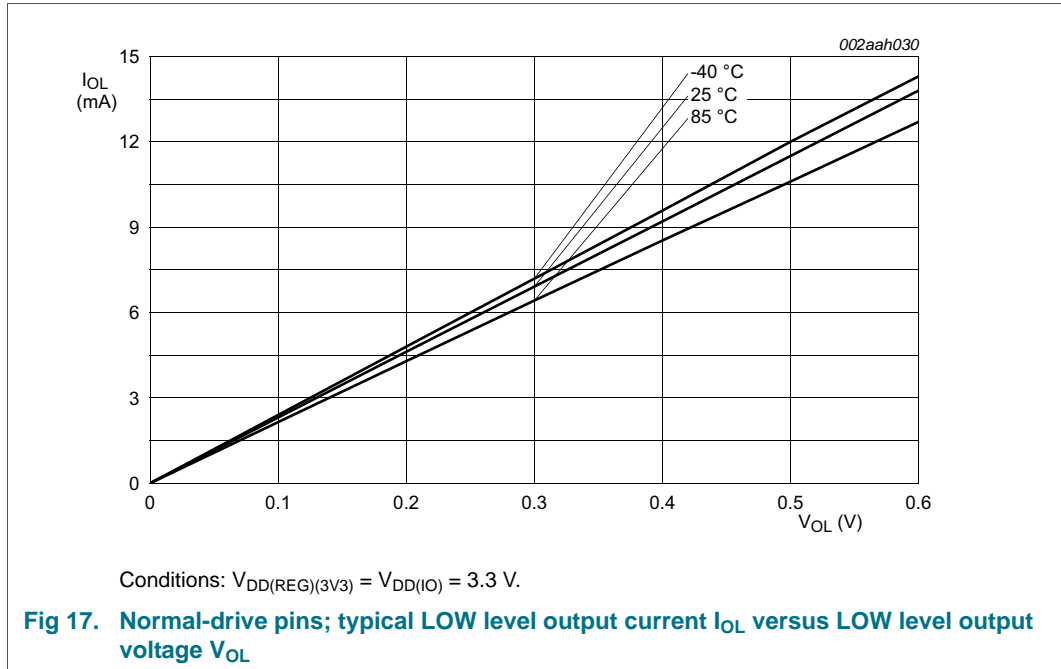

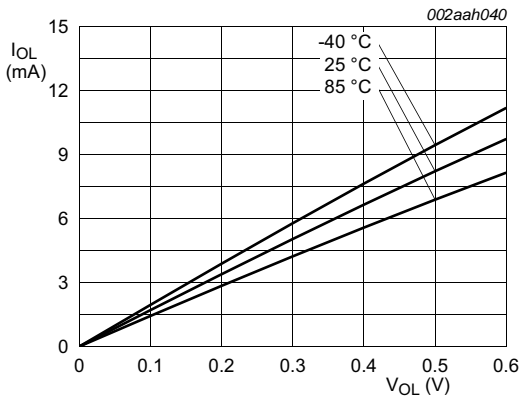

Conditions:  $V_{DD(REG)(3V3)} = V_{DD(IO)} = 3.3$  V; normal-drive; EHD = 0x0.

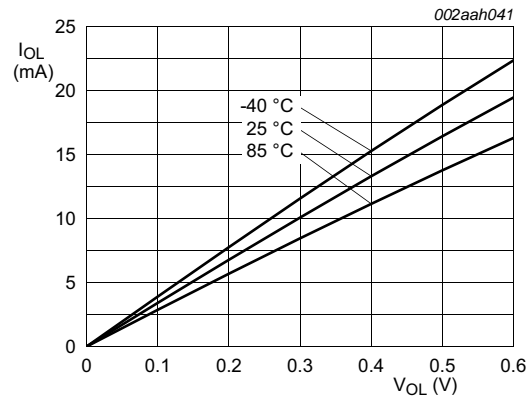

Conditions:  $V_{DD(REG)(3V3)} = V_{DD(IO)} = 3.3$  V; medium-drive; EHD = 0x1.

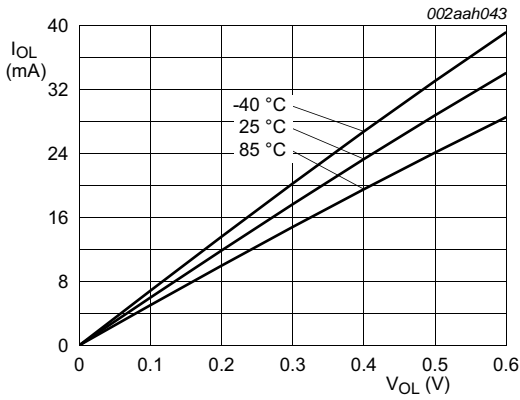

Conditions:  $V_{DD(REG)(3V3)} = V_{DD(IO)} = 3.3$  V; high-drive; EHD = 0x2.

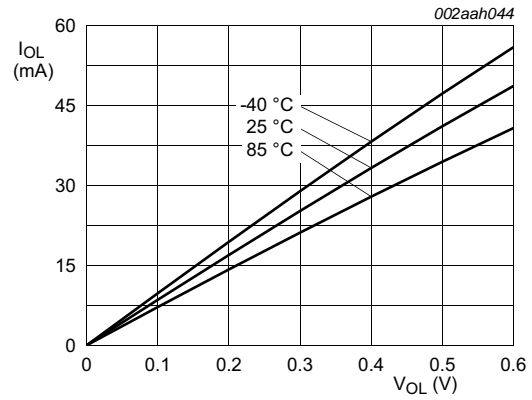

Conditions:  $V_{DD(REG)(3V3)} = V_{DD(IO)} = 3.3$  V; ultra high-drive; EHD = 0x3.

Fig 19. High-drive pins; typical LOW level output current  $I_{OL}$  versus LOW level output voltage  $V_{OL}$

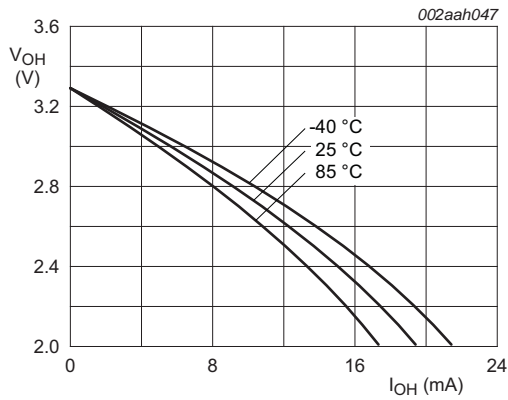

Conditions:  $V_{DD(REG)(3V3)} = V_{DD(IO)} = 3.3$  V; normal-drive; EHD = 0x0.

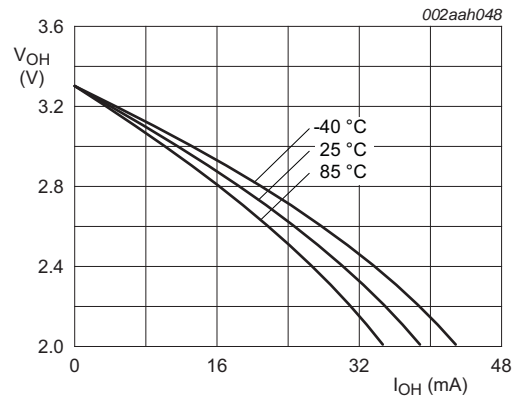

Conditions:  $V_{DD(REG)(3V3)} = V_{DD(IO)} = 3.3$  V; medium-drive; EHD = 0x1.

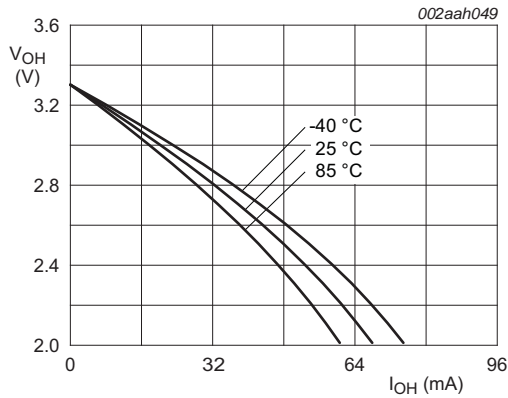

Conditions:  $V_{DD(REG)(3V3)} = V_{DD(IO)} = 3.3$  V; high-drive; EHD = 0x2.

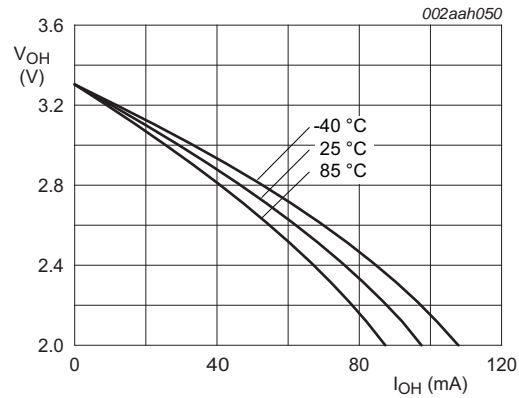

Conditions:  $V_{DD(REG)(3V3)} = V_{DD(IO)} = 3.3$  V; ultra high-drive; EHD = 0x3.

Fig 20. High-drive pins; typical HIGH level output voltage  $V_{OH}$  versus HIGH level output current  $I_{OH}$

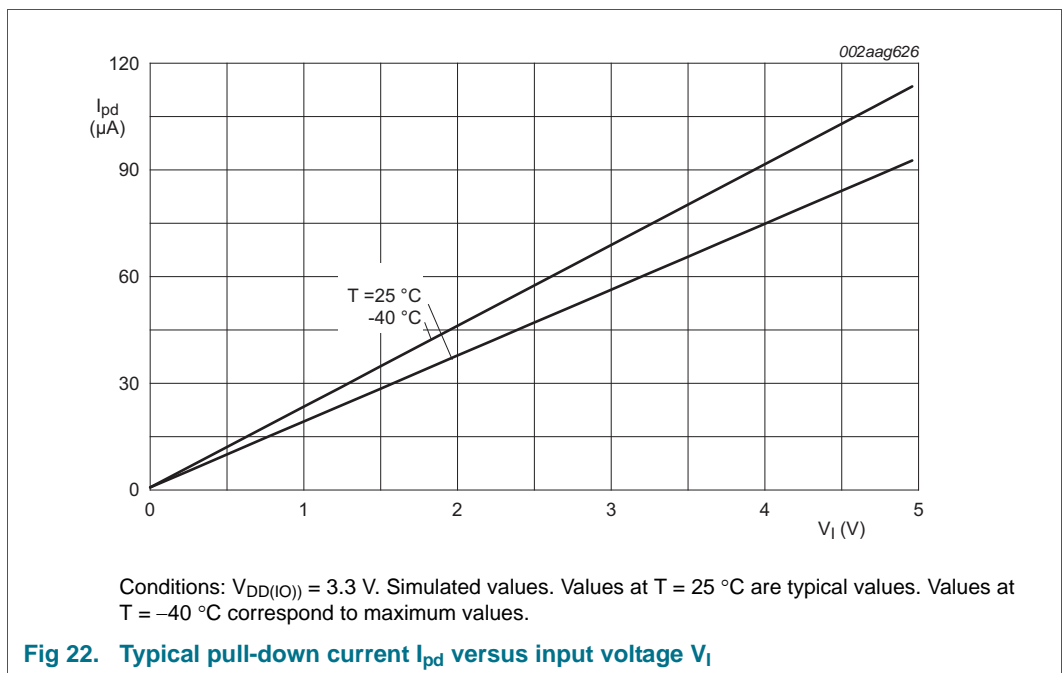
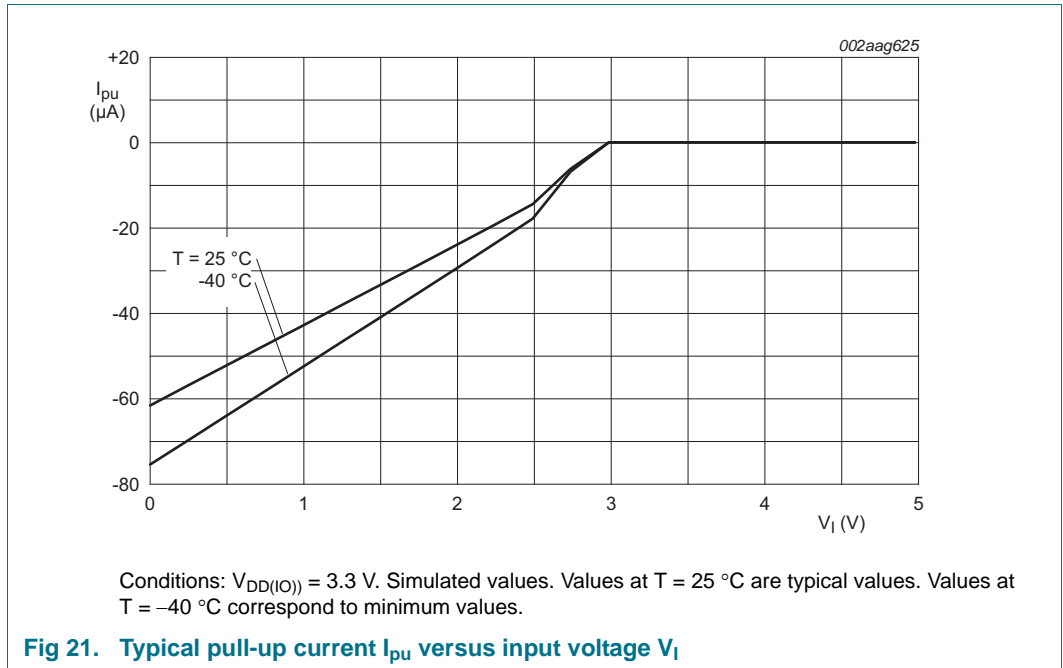

## 11. Dynamic characteristics

### 11.1 Wake-up times

**Table 15. Dynamic characteristic: Wake-up from Deep-sleep, Power-down, and Deep power-down modes**

$T_{amb} = -40\text{ }^{\circ}\text{C to }+85\text{ }^{\circ}\text{C}$

Symbol	Parameter	Conditions	Min	Typ <sup>[1]</sup>	Max	Unit
$t_{wake}$	wake-up time	from Sleep mode	<sup>[2]</sup> $3 \times T_{cy(clk)}$	$5 \times T_{cy(clk)}$	-	ns
		from Deep-sleep and Power-down mode	12	51	-	$\mu\text{s}$
		from Deep power-down mode	-	250	-	$\mu\text{s}$
		after reset	-	250	-	$\mu\text{s}$

[1] Typical ratings are not guaranteed. The values listed are at room temperature (25 °C), nominal supply voltages.

[2]  $T_{cy(clk)} = 1/\text{CCLK}$  with CCLK = CPU clock frequency.

### 11.2 External clock for oscillator in slave mode

**Remark:** The input voltage on the XTAL1/2 pins must be  $\leq 1.2\text{ V}$  (see [Table 10](#)). For connecting the oscillator to the XTAL pins, also see [Section 13.2](#) and [Section 13.4](#).

**Table 16. Dynamic characteristic: external clock**

$T_{amb} = -40\text{ }^{\circ}\text{C to }+85\text{ }^{\circ}\text{C}; V_{DD(I/O)}$  over specified ranges.<sup>[1]</sup>

Symbol	Parameter	Conditions	Min	Max	Unit
$f_{osc}$	oscillator frequency		1	25	MHz
$T_{cy(clk)}$	clock cycle time		40	1000	ns
$t_{CHCX}$	clock HIGH time		$T_{cy(clk)} \times 0.4$	$T_{cy(clk)} \times 0.6$	ns
$t_{CLCX}$	clock LOW time		$T_{cy(clk)} \times 0.4$	$T_{cy(clk)} \times 0.6$	ns

[1] Parameters are valid over operating temperature range unless otherwise specified.

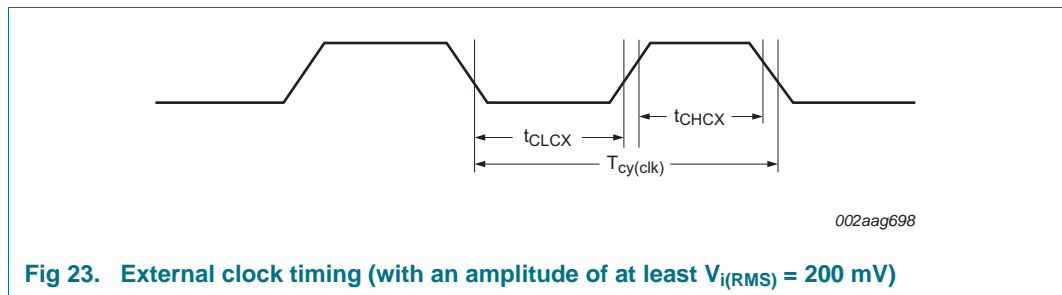

**Fig 23. External clock timing (with an amplitude of at least  $V_{i(RMS)} = 200\text{ mV}$ )**

### 11.3 Crystal oscillator

**Table 17. Dynamic characteristic: oscillator**

$T_{amb} = -40\text{ }^{\circ}\text{C}$  to  $+85\text{ }^{\circ}\text{C}$ ;  $V_{DD(I/O)}$  over specified ranges;  $2.2\text{ V} \leq V_{DD(REG)(3V3)} \leq 3.6\text{ V}$ .<sup>[1]</sup>

Symbol	Parameter	Conditions	Min	Typ <sup>[2]</sup>	Max	Unit	
<b>Low-frequency mode (1 MHz - 20 MHz)<sup>[5]</sup></b>							
$t_{jit(per)}$	period jitter time	5 MHz crystal	[3][4]	-	13.2	-	ps
		10 MHz crystal	-	-	6.6	-	ps
		15 MHz crystal	-	-	4.8	-	ps
<b>High-frequency mode (20 MHz - 25 MHz)<sup>[6]</sup></b>							
$t_{jit(per)}$	period jitter time	20 MHz crystal	[3][4]	-	4.3	-	ps
		25 MHz crystal	-	-	3.7	-	ps

- [1] Parameters are valid over operating temperature range unless otherwise specified.
- [2] Typical ratings are not guaranteed. The values listed are at room temperature (25 °C), nominal supply voltages.
- [3] Indicates RMS period jitter.
- [4] PLL-induced jitter is not included.
- [5] Select HF = 0 in the XTAL\_OSC\_CTRL register.
- [6] Select HF = 1 in the XTAL\_OSC\_CTRL register.

### 11.4 IRC oscillator

**Table 18. Dynamic characteristic: IRC oscillator**

$T_{amb} = -40\text{ }^{\circ}\text{C}$  to  $+85\text{ }^{\circ}\text{C}$ ;  $2.2\text{ V} \leq V_{DD(REG)(3V3)} \leq 3.6\text{ V}$ .<sup>[1]</sup>

Symbol	Parameter	Conditions	Min	Typ <sup>[2]</sup>	Max	Unit
$f_{osc(RC)}$	internal RC oscillator frequency	-	11.82	12.0	12.18	MHz

- [1] Parameters are valid over operating temperature range unless otherwise specified.
- [2] Typical ratings are not guaranteed. The values listed are at room temperature (25 °C), nominal supply voltages.

### 11.5 GPCLKIN

**Table 19. Dynamic characteristic: GPCLKIN**

$T_{amb} = 25\text{ }^{\circ}\text{C}$ ;  $2.4\text{ V} \leq V_{DD(REG)(3V3)} \leq 3.6\text{ V}$

Symbol	Parameter	Min	Typ	Max	Unit
GP_CLKIN	input frequency	-	-	25	MHz

### 11.6 I/O pins

**Table 20. Dynamic characteristic: I/O pins<sup>[1]</sup>**

$T_{amb} = -40\text{ }^{\circ}\text{C}$  to  $+85\text{ }^{\circ}\text{C}$ ;  $2.7\text{ V} \leq V_{DD(I/O)} \leq 3.6\text{ V}$ .

Symbol	Parameter	Conditions	Min	Typ	Max	Unit
<b>Standard I/O pins - normal drive strength</b>						
$t_r$	rise time	pin configured as output; EHS = 1	[2][3]	1.0	-	2.5 ns
$t_f$	fall time	pin configured as output; EHS = 1	[2][3]	0.9	-	2.5 ns
$t_r$	rise time	pin configured as output; EHS = 0	[2][3]	1.9	-	4.3 ns

**Table 20. Dynamic characteristic: I/O pins<sup>[1]</sup>** $T_{amb} = -40\text{ }^{\circ}\text{C to } +85\text{ }^{\circ}\text{C}; 2.7\text{ V} \leq V_{DD(I/O)} \leq 3.6\text{ V}.$ 

Symbol	Parameter	Conditions		Min	Typ	Max	Unit
$t_f$	fall time	pin configured as output; EHS = 0	[2][3]	1.9	-	4.0	ns
$t_r$	rise time	pin configured as input	[4]	0.3	-	1.3	ns
$t_f$	fall time	pin configured as input	[4]	0.2	-	1.2	ns
<b>I/O pins - high drive strength</b>							
$t_r$	rise time	pin configured as output; standard drive mode (EHD = 0x0)	[2][5]	4.3	-	7.9	ns
$t_f$	fall time	pin configured as output; standard drive mode (EHD = 0x0)	[2][5]	4.7	-	8.7	ns
$t_r$	rise time	pin configured as output; medium drive mode (EHD = 0x1)	[2][5]	3.2	-	5.7	ns
$t_f$	fall time	pin configured as output; medium drive mode (EHD = 0x1)	[2][5]	3.2	-	5.5	ns
$t_r$	rise time	pin configured as output; high drive mode (EHD = 0x2)	[2][5]	2.9	-	4.9	ns
$t_f$	fall time	pin configured as output; high drive mode (EHD = 0x2)	[2][5]	2.5	-	3.9	ns
$t_r$	rise time	pin configured as output; ultra-high drive mode (EHD = 0x3)	[2][5]	2.8	-	4.7	ns
$t_f$	fall time	pin configured as output; ultra-high drive mode (EHD = 0x3)	[2][5]	2.4	-	3.4	ns
$t_r$	rise time	pin configured as input	[4]	0.3	-	1.3	ns
$t_f$	fall time	pin configured as input	[4]	0.2	-	1.2	ns
<b>I/O pins - high-speed</b>							
$t_r$	rise time	pin configured as output; EHS = 1	[2][3]	350	-	670	ps
$t_f$	fall time	pin configured as output; EHS = 1	[2][3]	450	-	730	ps
$t_r$	rise time	pin configured as output; EHS = 0	[2][3]	1.0	-	1.9	ns
$t_f$	fall time	pin configured as output; EHS = 0	[2][3]	1.0	-	2.0	ns
$t_r$	rise time	pin configured as input	[4]	0.3	-	1.3	ns
$t_f$	fall time	pin configured as input	[4]	0.2	-	1.2	ns

[1] Simulated data.

[2] Simulated using 10 cm of 50  $\Omega$  PCB trace with 5 pF receiver input. Rise and fall times measured between 80 % and 20 % of the full output signal level.

[3] The slew rate is configured in the system control block in the SFSP registers using the EHS bit. See the LPC43xx user manual.

[4]  $C_L = 20$  pF. Rise and fall times measured between 90 % and 10 % of the full input signal level.

[5] The drive modes are configured in the system control block in the SFSP registers using the EHD bit. See the LPC43xx user manual.

## 11.7 RTC oscillator

**Table 21. Dynamic characteristic: RTC oscillator**

$T_{amb} = -40\text{ °C to }+85\text{ °C}$ ;  $2.2\text{ V} \leq V_{DD(REG)(3V3)} \leq 3.6\text{ V}$  or  $2.2\text{ V} \leq V_{BAT} \leq 3.6\text{ V}$  [1]; typical  $C_{RTCX1/2} = 20\text{ pF}$ ; also see [Section 13.3](#).

Symbol	Parameter	Conditions	Min	Typ <sup>[2]</sup>	Max	Unit
$f_{i(RTC)}$	RTC input frequency	-	-	32.768	-	kHz
$I_{DD(RTC)}$	RTC supply current			280	800	nA

[1] Parameters are valid over operating temperature range unless otherwise specified.

[2] Typical ratings are not guaranteed. The values listed are at room temperature (25 °C), nominal supply voltages.

## 11.8 I<sup>2</sup>C-bus

**Table 22. Dynamic characteristic: I<sup>2</sup>C-bus pins**

$T_{amb} = -40\text{ °C to }+85\text{ °C}$ ;  $2.2\text{ V} \leq V_{DD(REG)(3V3)} \leq 3.6\text{ V}$  [1]

Symbol	Parameter	Conditions	Min	Max	Unit	
$f_{SCL}$	SCL clock frequency	Standard-mode	0	100	kHz	
		Fast-mode	0	400	kHz	
		Fast-mode Plus	0	1	MHz	
$t_f$	fall time	[3][4][5][6] of both SDA and SCL signals	Standard-mode	-	300	ns
			Fast-mode	$20 + 0.1 \times C_b$	300	ns
			Fast-mode Plus	-	120	ns
$t_{LOW}$	LOW period of the SCL clock	Standard-mode	4.7	-	$\mu\text{s}$	
		Fast-mode	1.3	-	$\mu\text{s}$	
		Fast-mode Plus	0.5	-	$\mu\text{s}$	
$t_{HIGH}$	HIGH period of the SCL clock	Standard-mode	4.0	-	$\mu\text{s}$	
		Fast-mode	0.6	-	$\mu\text{s}$	
		Fast-mode Plus	0.26	-	$\mu\text{s}$	
$t_{HD;DAT}$	data hold time	[2][3][7]	Standard-mode	0	-	$\mu\text{s}$
			Fast-mode	0	-	$\mu\text{s}$
			Fast-mode Plus	0	-	$\mu\text{s}$
$t_{SU;DAT}$	data set-up time	[8][9]	Standard-mode	250	-	ns
			Fast-mode	100	-	ns
			Fast-mode Plus	50	-	ns

[1] Parameters are valid over operating temperature range unless otherwise specified. See the I<sup>2</sup>C-bus specification *UM10204* for details.

[2]  $t_{HD;DAT}$  is the data hold time that is measured from the falling edge of SCL; applies to data in transmission and the acknowledge.

[3] A device must internally provide a hold time of at least 300 ns for the SDA signal (with respect to the  $V_{IH}(\text{min})$  of the SCL signal) to bridge the undefined region of the falling edge of SCL.

[4]  $C_b$  = total capacitance of one bus line in pF. If mixed with Hs-mode devices, faster fall times are allowed.

[5] The maximum  $t_f$  for the SDA and SCL bus lines is specified at 300 ns. The maximum fall time for the SDA output stage  $t_f$  is specified at 250 ns. This allows series protection resistors to be connected in between the SDA and the SCL pins and the SDA/SCL bus lines without exceeding the maximum specified  $t_f$ .

[6] In Fast-mode Plus, fall time is specified the same for both output stage and bus timing. If series resistors are used, designers should

allow for this when considering bus timing.

- [7] The maximum  $t_{HD;DAT}$  could be 3.45  $\mu s$  and 0.9  $\mu s$  for Standard-mode and Fast-mode but must be less than the maximum of  $t_{VD;DAT}$  or  $t_{VD;ACK}$  by a transition time. This maximum must only be met if the device does not stretch the LOW period ( $t_{LOW}$ ) of the SCL signal. If the clock stretches the SCL, the data must be valid by the set-up time before it releases the clock.
- [8]  $t_{SU;DAT}$  is the data set-up time that is measured with respect to the rising edge of SCL; applies to data in transmission and the acknowledge.
- [9] A Fast-mode I<sup>2</sup>C-bus device can be used in a Standard-mode I<sup>2</sup>C-bus system but the requirement  $t_{SU;DAT} = 250$  ns must then be met. This will automatically be the case if the device does not stretch the LOW period of the SCL signal. If such a device does stretch the LOW period of the SCL signal, it must output the next data bit to the SDA line  $t_{r(max)} + t_{SU;DAT} = 1000 + 250 = 1250$  ns (according to the Standard-mode I<sup>2</sup>C-bus specification) before the SCL line is released. Also the acknowledge timing must meet this set-up time.

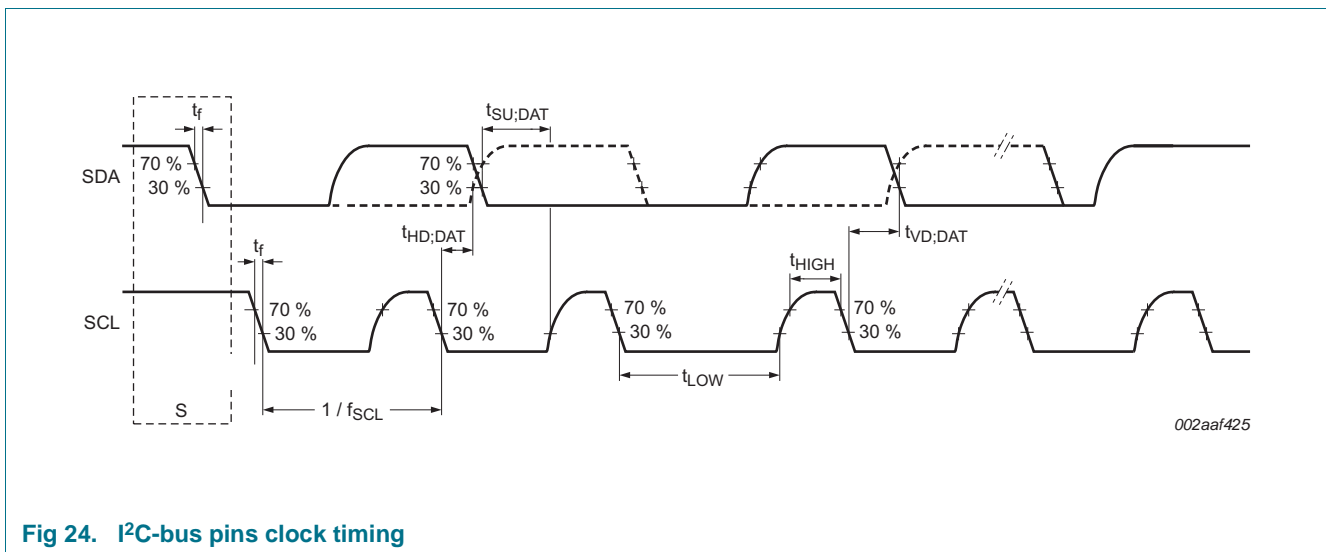

Fig 24. I<sup>2</sup>C-bus pins clock timing

### 11.9 I<sup>2</sup>S-bus interface

Table 23. Dynamic characteristics: I<sup>2</sup>S-bus interface pins

$T_{amb} = 25$  °C;  $2.2 V \leq V_{DD(REG)(3V3)} \leq 3.6 V$ ;  $2.7 V \leq V_{DD(IO)} \leq 3.6 V$ ;  $C_L = 20$  pF. Conditions and data refer to I2S0 and I2S1 pins. Simulated values.

Symbol	Parameter	Conditions	Min	Typ	Max	Unit
<b>common to input and output</b>						
$t_r$	rise time		-	4	-	ns
$t_f$	fall time		-	4	-	ns
$t_{WH}$	pulse width HIGH	on pins I2Sx_TX_SCK and I2Sx_RX_SCK	36	-	-	ns
$t_{WL}$	pulse width LOW	on pins I2Sx_TX_SCK and I2Sx_RX_SCK	36	-	-	ns
<b>output</b>						
$t_{V(Q)}$	data output valid time	on pin I2Sx_TX_SDA <a href="#">[1]</a>	-	4.4	-	ns
		on pin I2Sx_TX_WS	-	4.3	-	ns
<b>input</b>						
$t_{su(D)}$	data input set-up time	on pin I2Sx_RX_SDA <a href="#">[1]</a>	-	0	-	ns
		on pin I2Sx_RX_WS		0.20		ns
$t_{h(D)}$	data input hold time	on pin I2Sx_RX_SDA <a href="#">[1]</a>	-	3.7	-	ns
		on pin I2Sx_RX_WS	-	3.9	-	ns

- [1] Clock to the I<sup>2</sup>S-bus interface BASE\_APB1\_CLK = 150 MHz; peripheral clock to the I<sup>2</sup>S-bus interface PCLK = BASE\_APB1\_CLK / 12. I<sup>2</sup>S clock cycle time  $T_{cy(clk)} = 79.2$  ns; corresponds to the SCK signal in the I<sup>2</sup>S-bus specification.

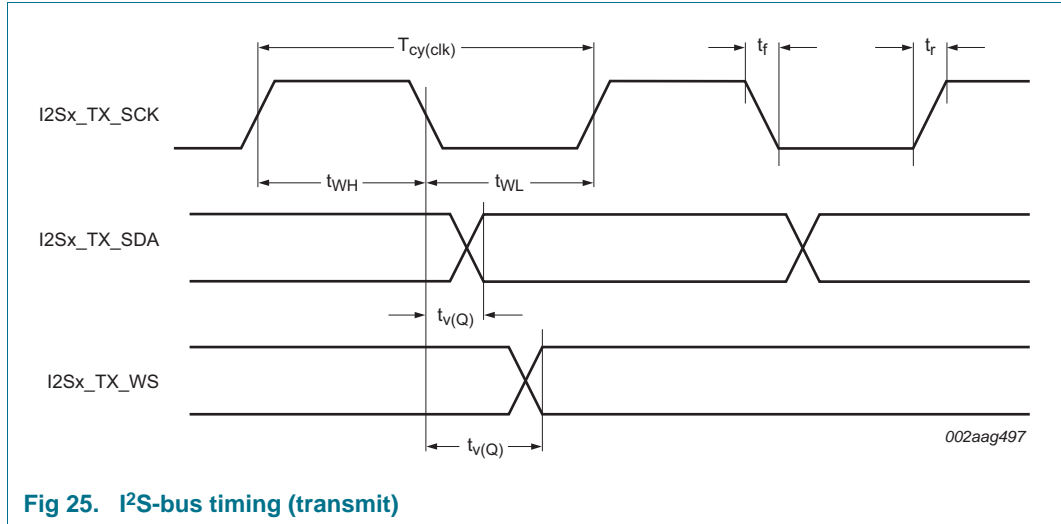

Fig 25. I<sup>2</sup>S-bus timing (transmit)

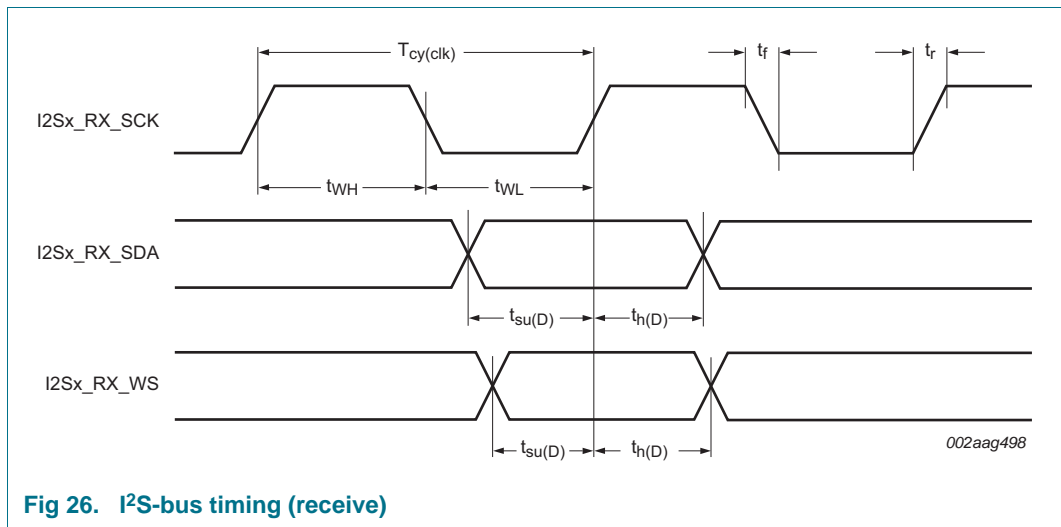

Fig 26. I<sup>2</sup>S-bus timing (receive)

## 11.10 USART interface

Table 24. USART dynamic characteristics

$T_{amb} = -40$  °C to  $85$  °C;  $2.2$  V  $\leq V_{DD(REG)(3V3)} \leq 3.6$  V;  $2.7$  V  $\leq V_{DD(I/O)} \leq 3.6$  V;  $C_L = 20$  pF. EHS = 1 for all pins. Simulated values.

Symbol	Parameter	Min	Max	Unit
<b>USART master (in synchronous mode)</b>				
$t_{su(D)}$	data input set-up time	26.6	-	ns
$t_{h(D)}$	data input hold time	0	-	ns
$t_{v(Q)}$	data output valid time	0	8.8	ns

**Table 24. USART dynamic characteristics**

$T_{amb} = -40\text{ }^{\circ}\text{C}$  to  $85\text{ }^{\circ}\text{C}$ ;  $2.2\text{ V} \leq V_{DD(REG)(3V3)} \leq 3.6\text{ V}$ ;  $2.7\text{ V} \leq V_{DD(I/O)} \leq 3.6\text{ V}$ ;  $C_L = 20\text{ pF}$ .  $EHS = 1$  for all pins. Simulated values.

Symbol	Parameter	Min	Max	Unit
<b>USART slave (in synchronous mode)</b>				
$t_{su(D)}$	data input set-up time	1.2	-	ns
$t_{h(D)}$	data input hold time	0.4	-	ns
$t_{v(Q)}$	data output valid time	5.5	24	ns

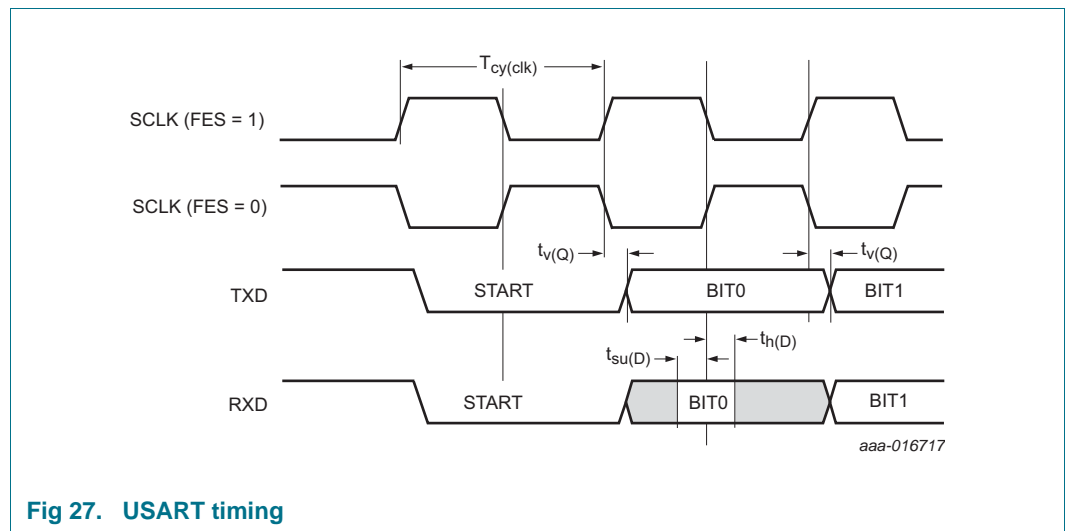

**Fig 27. USART timing**

## 11.11 SSP interface

**Table 25. Dynamic characteristics: SSP pins in SPI mode**

$T_{amb} = -40\text{ }^{\circ}\text{C}$  to  $+85\text{ }^{\circ}\text{C}$ ;  $2.2\text{ V} \leq V_{DD(REG)(3V3)} \leq 3.6\text{ V}$ ;  $2.7\text{ V} \leq V_{DD(I/O)} \leq 3.6\text{ V}$ ;  $C_L = 20\text{ pF}$ . Sampled at 10 % and 90 % of the signal level;  $EHS = 1$  for all pins. Simulated values.

Symbol	Parameter	Conditions	Min	Typ	Max	Unit	
<b>SSP master</b>							
$T_{cy(clk)}$	clock cycle time	full-duplex mode	[1]	$1/(25.5 \times 10^6)$	-	-	s
		when only transmitting		$1/(51 \times 10^6)$	-	-	s
$t_{DS}$	data set-up time	in SPI mode	13.6	-	-	ns	
$t_{DH}$	data hold time	in SPI mode	-3.8	-	-	ns	
$t_{v(Q)}$	data output valid time	in SPI mode	-	-	6.0	ns	
$t_{h(Q)}$	data output hold time	in SPI mode	-1.1	-	-	ns	
$t_{lead}$	lead time	continuous transfer mode SPI mode; CPOL = 0; CPHA = 0		$T_{cy(clk)} + 3.2$	-	$T_{cy(clk)} + 6.1$	ns
		SPI mode; CPOL = 0; CPHA = 1		$0.5 \times T_{cy(clk)} + 3.2$	-	$0.5 \times T_{cy(clk)} + 6.1$	ns
		SPI mode; CPOL = 1; CPHA = 0		$T_{cy(clk)} + 3.2$	-	$T_{cy(clk)} + 6.1$	ns
		SPI mode; CPOL = 1; CPHA = 1		$0.5 \times T_{cy(clk)} + 3.2$	-	$0.5 \times T_{cy(clk)} + 6.1$	ns
		synchronous serial frame mode		$0.5 \times T_{cy(clk)} + 3.2$	-	$0.5 \times T_{cy(clk)} + 6.1$	ns
		microwire frame format		$T_{cy(clk)} + 3.2$	-	$T_{cy(clk)} + 6.1$	ns
$t_{lag}$	lag time	continuous transfer mode SPI mode; CPOL = 0; CPHA = 0		$0.5 \times T_{cy(clk)}$	-	-	ns
		SPI mode; CPOL = 0; CPHA = 1		$T_{cy(clk)}$	-	-	ns
		SPI mode; CPOL = 1; CPHA = 0		$0.5 \times T_{cy(clk)}$	-	-	ns
		SPI mode; CPOL = 1; CPHA = 1		$T_{cy(clk)}$	-	-	ns
		synchronous serial frame mode		$T_{cy(clk)}$	-	-	ns
		microwire frame format		$0.5 \times T_{cy(clk)}$	-	-	ns

**Table 25. Dynamic characteristics: SSP pins in SPI mode**

$T_{amb} = -40\text{ °C to }+85\text{ °C}$ ;  $2.2\text{ V} \leq V_{DD(REG)(3V3)} \leq 3.6\text{ V}$ ;  $2.7\text{ V} \leq V_{DD(I/O)} \leq 3.6\text{ V}$ ;  $C_L = 20\text{ pF}$ . Sampled at 10 % and 90 % of the signal level; EHS = 1 for all pins. Simulated values.

Symbol	Parameter	Conditions	Min	Typ	Max	Unit
$t_d$	delay time	continuous transfer mode SPI mode; CPOL = 0; CPHA = 0	-	$0.5 \times T_{cy(clk)}$	-	ns
		SPI mode; CPOL = 0; CPHA = 1	-	n/a	-	ns
		SPI mode; CPOL = 1; CPHA = 0	-	$0.5 \times T_{cy(clk)}$	-	ns
		SPI mode; CPOL = 1; CPHA = 1	-	n/a	-	ns
		synchronous serial frame mode	-	$T_{cy(clk)}$	-	ns
		microwire frame format	-	n/a	-	ns
<b>SSP slave</b>						
PCLK	Peripheral clock frequency		-	-	204	MHz
$T_{cy(clk)}$	clock cycle time		<a href="#">2</a> $1/(11 \times 10^6)$	-	-	s
$t_{DS}$	data set-up time	in SPI mode	1.15	-	-	ns
$t_{DH}$	data hold time	in SPI mode	0.5	-	-	ns
$t_{v(Q)}$	data output valid time	in SPI mode	-	-	$[4 \times (1/PCLK)] + 3$	ns
$t_{h(Q)}$	data output hold time	in SPI mode	5.1	-	-	ns
$t_{lead}$	lead time	continuous transfer mode SPI mode; CPOL = 0; CPHA = 0	$T_{cy(clk)} + 2.2$	-	-	ns
		SPI mode; CPOL = 0; CPHA = 1	$0.5 \times T_{cy(clk)} + 2.2$	-	-	ns
		SPI mode; CPOL = 1; CPHA = 0	$T_{cy(clk)} + 2.2$	-	-	ns
		SPI mode; CPOL = 1; CPHA = 1	$0.5 \times T_{cy(clk)} + 2.2$	-	-	ns
		synchronous serial frame mode	$0.5 \times T_{cy(clk)} + 2.2$	-	-	ns
		microwire frame format	$T_{cy(clk)} + 2.2$	-	-	ns

**Table 25. Dynamic characteristics: SSP pins in SPI mode**

$T_{amb} = -40\text{ }^{\circ}\text{C}$  to  $+85\text{ }^{\circ}\text{C}$ ;  $2.2\text{ V} \leq V_{DD(REG)(3V3)} \leq 3.6\text{ V}$ ;  $2.7\text{ V} \leq V_{DD(IO)} \leq 3.6\text{ V}$ ;  $C_L = 20\text{ pF}$ . Sampled at 10 % and 90 % of the signal level; EHS = 1 for all pins. Simulated values.

Symbol	Parameter	Conditions	Min	Typ	Max	Unit
$t_{lag}$	lag time	continuous transfer mode SPI mode; CPOL = 0; CPHA = 0	$0.5T_{cy(clk)} + 0.2$	-	-	ns
		SPI mode; CPOL = 0; CPHA = 1	$T_{cy(clk)} + 0.2$	-	-	ns
		SPI mode; CPOL = 1; CPHA = 0	$0.5 \times T_{cy(clk)} + 0.2$	-	-	ns
		SPI mode; CPOL = 1; CPHA = 1	$T_{cy(clk)} + 0.2$	-	-	ns
		synchronous serial frame mode	$T_{cy(clk)} + 0.2$	-	-	ns
		microwire frame format	$0.5 \times T_{cy(clk)}$	-	-	ns
$t_d$	delay time	continuous transfer mode SPI mode; CPOL = 0; CPHA = 0	-	$0.5 \times T_{cy(clk)}$	-	ns
		SPI mode; CPOL = 0; CPHA = 1	-	n/a	-	ns
		SPI mode; CPOL = 1; CPHA = 0	-	$0.5 \times T_{cy(clk)}$	-	ns
		SPI mode; CPOL = 1; CPHA = 1	-	n/a	-	ns
		synchronous serial frame mode	-	$T_{cy(clk)}$	-	ns
		microwire frame format	-	n/a	-	ns

[1]  $T_{cy(clk)} = (SSPCLKDIV \times (1 + SCR) \times CPSDVSR) / f_{main}$ . The clock cycle time derived from the SPI bit rate  $T_{cy(clk)}$  is a function of the main clock frequency  $f_{main}$ , the SSP peripheral clock divider (SSPCLKDIV), the SSP SCR parameter (specified in the SSPOCR0 register), and the SSP CPSDVSR parameter (specified in the SSP clock prescale register).

[2]  $T_{cy(clk)} \geq 12 \times T_{cy(PCLK)}$ .

## 11.12 SPI interface

**Table 26. Dynamic characteristics: SPI**

$T_{amb} = -40\text{ }^{\circ}\text{C}$  to  $+85\text{ }^{\circ}\text{C}$ ;  $2.2\text{ V} \leq V_{DD(REG)(3V3)} \leq 3.6\text{ V}$ ;  $2.7\text{ V} \leq V_{DD(IO)} \leq 3.6\text{ V}$ . Simulated values.

Symbol	Parameter	Conditions	Min	Typ	Max	Unit
$T_{cy(PCLK)}$	PCLK cycle time		5			ns
$T_{cy(clk)}$	clock cycle time	[1]	40	-	-	ns
<b>Master</b>						
$t_{DS}$	data set-up time		7.2	-	-	ns
$t_{DH}$	data hold time		0	-	-	ns
$t_{V(Q)}$	data output valid time		-	-	3.7	ns
$t_{h(Q)}$	data output hold time		-	-	1.2	ns
<b>Slave</b>						
$t_{DS}$	data set-up time		1.2	-	-	ns
$t_{DH}$	data hold time		$3 \times T_{cy(PCLK)} + 0.54$	-	-	ns
$t_{V(Q)}$	data output valid time		-	-	$3 \times T_{cy(PCLK)} + 9.7$	ns
$t_{h(Q)}$	data output hold time		-	-	$2 \times T_{cy(PCLK)} + 7.1$	ns

[1]  $T_{cy(clk)} = 8/BASE\_SPI\_CLK$ .  $T_{cy(PCLK)} = 1/BASE\_SPI\_CLK$ .

11.13 SSP/SPI timing diagrams

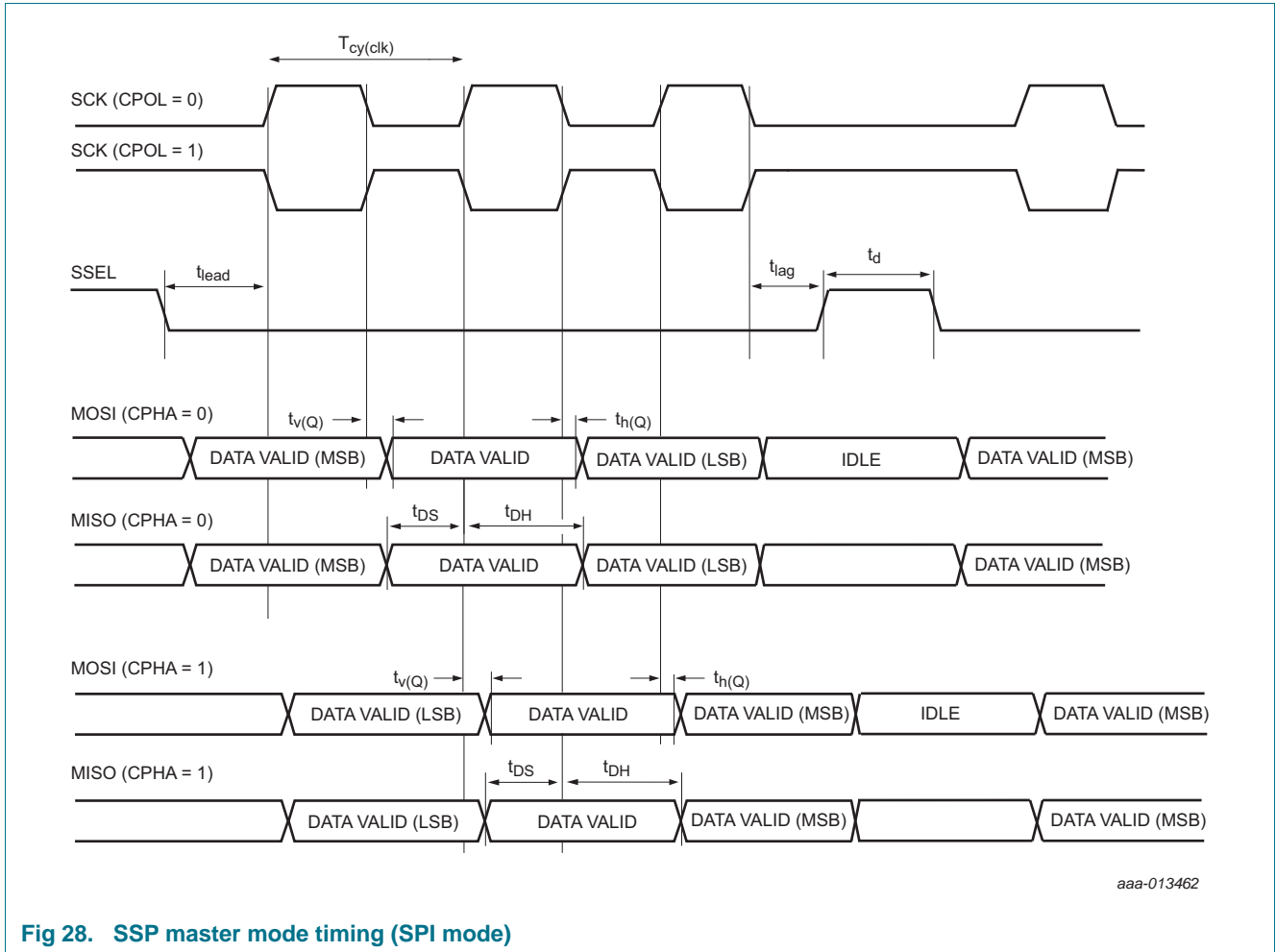

Fig 28. SSP master mode timing (SPI mode)

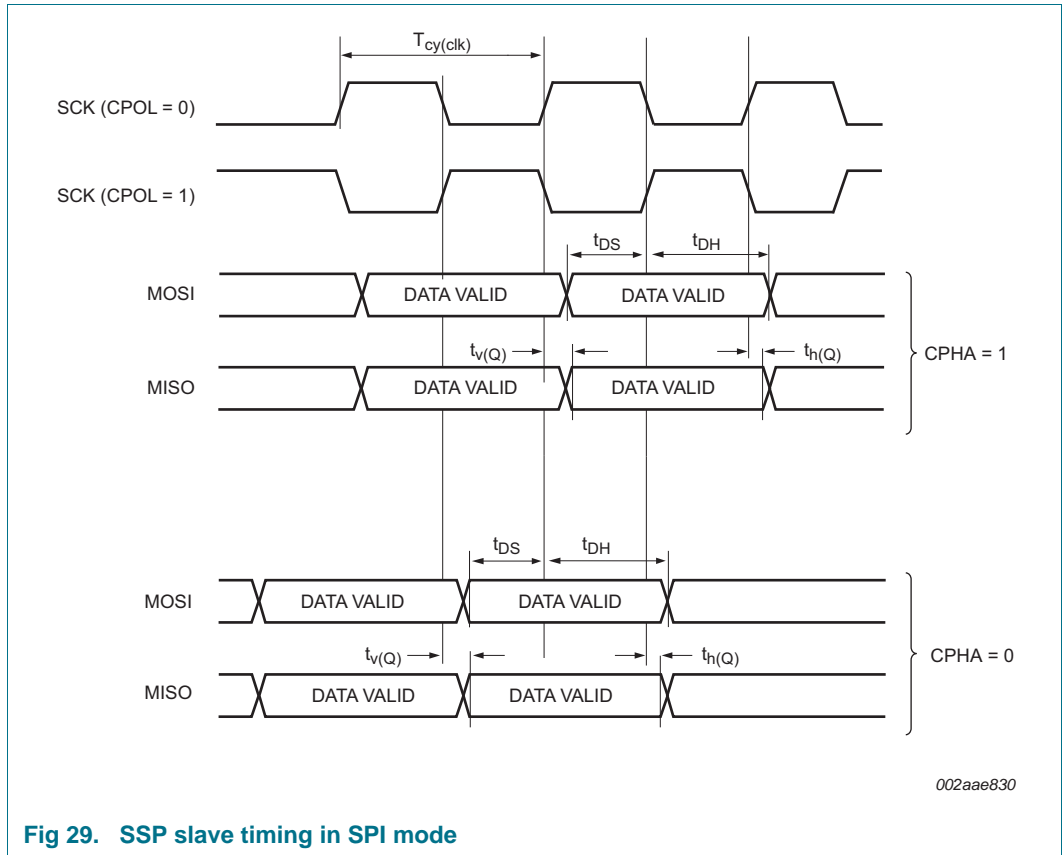

Fig 29. SSP slave timing in SPI mode

11.14 SPIFI

**Table 27. Dynamic characteristics: SPIFI**

$T_{amb} = -40\text{ }^{\circ}\text{C}$  to  $85\text{ }^{\circ}\text{C}$ ;  $2.2\text{ V} \leq V_{DD(REG)(3V3)} \leq 3.6\text{ V}$ ;  $2.7\text{ V} \leq V_{DD(I/O)} \leq 3.6\text{ V}$ .  $C_L = 20\text{ pF}$ . Sampled at 90 % and 10 % of the signal level. EHS = 1 for all pins. Simulated values.

Symbol	Parameter	Min	Max	Unit
$T_{cy(clk)}$	clock cycle time	9.6	-	ns
$t_{DS}$	data set-up time	2.8	-	ns
$t_{DH}$	data hold time	0	-	ns
$t_{v(Q)}$	data output valid time	-	2.6	ns
$t_{h(Q)}$	data output hold time	0.8	-	ns

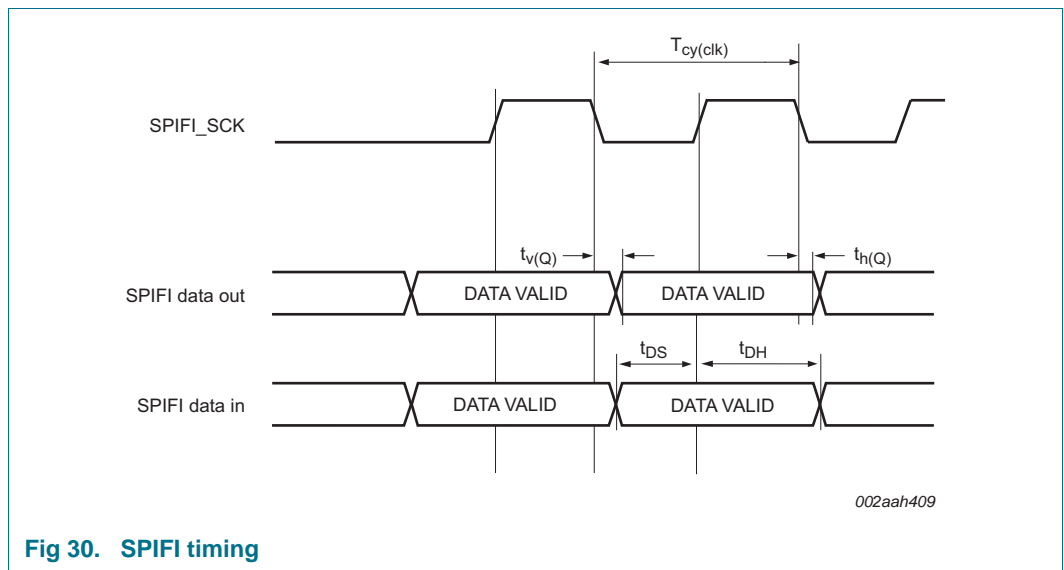

Fig 30. SPIFI timing

11.15 SGPIO timing

The following considerations apply to SGPIO timing:

- SGPIO input signals are synchronized by the internal clock SGPIO\_CLOCK. To guarantee that no samples are missed, all input signals should have a duration of at least one SGPIO\_CLOCK cycle plus the set-up and hold times.
- When an external clock input is used to generate output data, synchronization causes a latency of at least one SGPIO\_CLOCK cycle. The maximum output data rate is one output every two SGPIO\_CLOCK cycles.
- Synchronization also causes a latency of one SGPIO\_CLOCK cycle when sampling several inputs. This may cause inputs with very similar timings to be sampled with a difference of one SGPIO\_CLOCK cycle.

**Table 28. Dynamic characteristics: SGPIO**

$T_{amb} = -40\text{ }^{\circ}\text{C to } +85\text{ }^{\circ}\text{C}; 2.2\text{ V} \leq V_{DD(REG)(3V3)} \leq 3.6\text{ V}; 2.7\text{ V} \leq V_{DD(IO)} \leq 3.6\text{ V}$ . Simulated values.

Symbol	Parameter	Conditions	Min	Typ	Max	Unit
$t_{su(D)}$	data input set-up time		2	-	-	ns
$t_{h(D)}$	data input hold time	[1]	$T_{SGPIO} + 2$	-	-	ns
$t_{su(D)}$	data input set-up time	sampled by SGPIO_CLOCK	[1]	$T_{SGPIO} + 2$	-	ns
$t_{h(D)}$	data input hold time	sampled by SGPIO_CLOCK	[1]	$T_{SGPIO} + 2$	-	ns
$t_{v(Q)}$	data output valid time	[1]	-	-	$2 \times T_{SGPIO}$	ns
$t_{h(Q)}$	data output hold time	[1]	$T_{SGPIO}$	-	-	ns
$t_{v(Q)}$	data output valid time	sampled by SGPIO_CLOCK	[1]	-	3	ns
$t_{h(Q)}$	data output hold time	sampled by SGPIO_CLOCK	[1]	-	3	ns

[1] SGPIO\_CLOCK is the internally generated SGPIO clock.  $T_{SGPIO} = 1/f_{SGPIO\_CLOCK}$ .

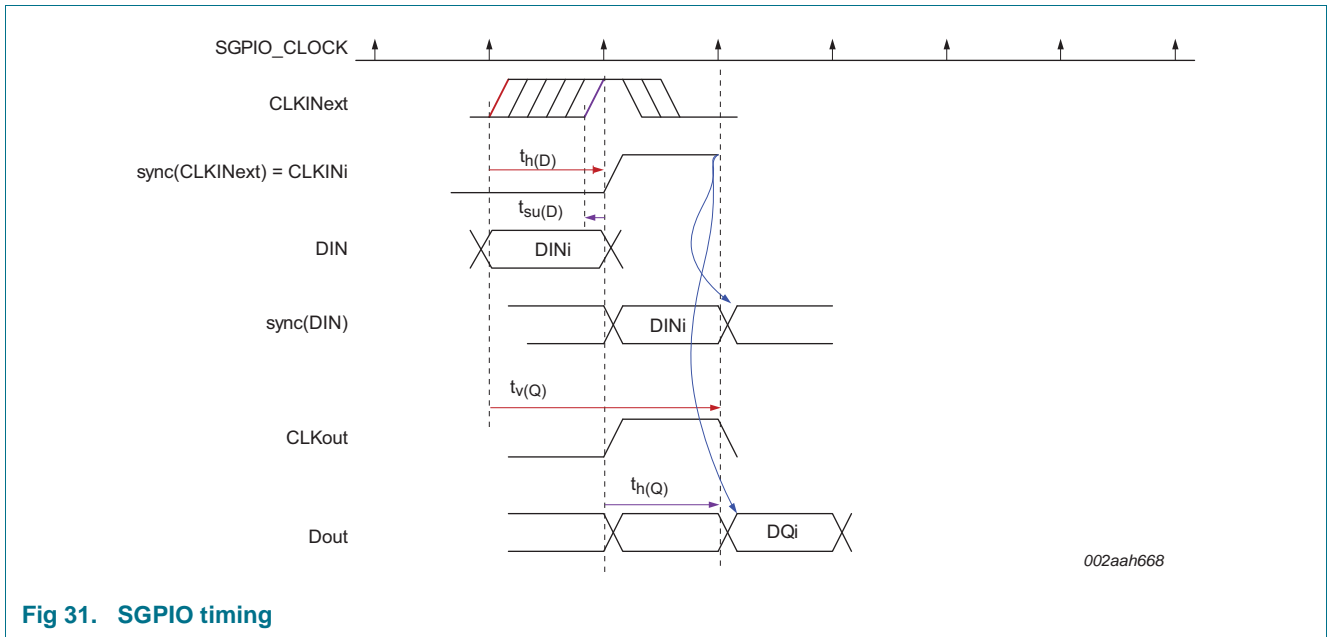

**Fig 31. SGPIO timing**

### 11.16 External memory interface

**Table 29. Dynamic characteristics: Static asynchronous external memory interface**

$C_L = 22\text{ pF}$  for EMC\_Dn  $C_L = 20\text{ pF}$  for all others;  $T_{amb} = -40\text{ }^\circ\text{C}$  to  $85\text{ }^\circ\text{C}$ ;  $2.2\text{ V} \leq V_{DD(REG)(3V3)} \leq 3.6\text{ V}$ ;  $2.7\text{ V} \leq V_{DD(I/O)} \leq 3.6\text{ V}$ ; values guaranteed by design. Timing parameters are given for single memory access cycles. In a normal read operation, the EMC changes the address while CS is asserted which results in multiple memory accesses.

Symbol	Parameter <sup>[1]</sup>	Conditions	Min	Typ	Max	Unit
<b>Read cycle parameters</b>						
t <sub>CSLAV</sub>	$\overline{\text{CS}}$ LOW to address valid time		-3.1	-	1.6	ns
t <sub>CSLOEL</sub>	$\overline{\text{CS}}$ LOW to $\overline{\text{OE}}$ LOW time		<sup>[2]</sup> $-0.6 + T_{cy(\text{clk})} \times \text{WAITOEN}$	-	$1.3 + T_{cy(\text{clk})} \times \text{WAITOEN}$	ns
t <sub>CSLBLSL</sub>	$\overline{\text{CS}}$ LOW to $\overline{\text{BLS}}$ LOW time	PB = 1	-0.7	-	1.8	ns
t <sub>OELOEH</sub>	$\overline{\text{OE}}$ LOW to $\overline{\text{OE}}$ HIGH time		<sup>[2]</sup> $-0.6 + (\text{WAITRD} - \text{WAITOEN} + 1) \times T_{cy(\text{clk})}$	-	$-0.4 + (\text{WAITRD} - \text{WAITOEN} + 1) \times T_{cy(\text{clk})}$	ns
t <sub>am</sub>	memory access time		-	-	$-16 + (\text{WAITRD} - \text{WAITOEN} + 1) \times T_{cy(\text{clk})}$	ns
t <sub>h(D)</sub>	data input hold time		-16	-	-	ns
t <sub>CSHBLSH</sub>	$\overline{\text{CS}}$ HIGH to $\overline{\text{BLS}}$ HIGH time	PB = 1	-0.4	-	1.9	ns
t <sub>CSHOEH</sub>	CS HIGH to $\overline{\text{OE}}$ HIGH time		-0.4	-	1.4	ns
t <sub>OEHANV</sub>	$\overline{\text{OE}}$ HIGH to address invalid	PB = 1	-2.0	-	2.6	ns
t <sub>CSHEOR</sub>	$\overline{\text{CS}}$ HIGH to end of read time		<sup>[3]</sup> -2.0	-	0	ns
t <sub>CSLSOR</sub>	$\overline{\text{CS}}$ LOW to start of read time		<sup>[4]</sup> 0	-	1.8	ns
<b>Write cycle parameters</b>						
t <sub>CSLAV</sub>	$\overline{\text{CS}}$ LOW to address valid time		-3.1	-	1.6	ns
t <sub>CSLDV</sub>	$\overline{\text{CS}}$ LOW to data valid time		-3.1	-	1.5	ns
t <sub>CSLWEL</sub>	$\overline{\text{CS}}$ LOW to $\overline{\text{WE}}$ LOW time	PB = 1	-1.5+ $(\text{WAITWEN} + 1) \times T_{cy(\text{clk})}$	-	0.2+ $(\text{WAITWEN} + 1) \times T_{cy(\text{clk})}$	ns
t <sub>CSLBLSL</sub>	$\overline{\text{CS}}$ LOW to $\overline{\text{BLS}}$ LOW time	PB = 1	-0.7	-	1.8	ns
t <sub>WELWEH</sub>	$\overline{\text{WE}}$ LOW to $\overline{\text{WE}}$ HIGH time	PB = 1	<sup>[2]</sup> $-0.6 + (\text{WAITWR} - \text{WAITWEN} + 1) \times T_{cy(\text{clk})}$	-	$-0.4 + (\text{WAITWR} - \text{WAITWEN} + 1) \times T_{cy(\text{clk})}$	ns
t <sub>WEHDNV</sub>	$\overline{\text{WE}}$ HIGH to data invalid time	PB = 1	<sup>[2]</sup> $-0.9 + T_{cy(\text{clk})}$	-	$2.3 + T_{cy(\text{clk})}$	ns
t <sub>WEHEOW</sub>	$\overline{\text{WE}}$ HIGH to end of write time	PB = 1	<sup>[2]</sup> $-0.4 + T_{cy(\text{clk})}$ <sup>[5]</sup>	-	$-0.3 + T_{cy(\text{clk})}$	ns
t <sub>CSLBLSL</sub>	$\overline{\text{CS}}$ LOW to $\overline{\text{BLS}}$ LOW	PB = 0	-0.7+ $(\text{WAITWEN} + 1) \times T_{cy(\text{clk})}$	-	1.8+ $(\text{WAITWEN} + 1) \times T_{cy(\text{clk})}$	ns





**Table 30. Dynamic characteristics: Dynamic external memory interface**

Simulated data over temperature and process range;  $C_L = 10\text{ pF}$  for  $\overline{EMC\_DYCSn}$ ,  $\overline{EMC\_RAS}$ ,  $\overline{EMC\_CAS}$ ,  $\overline{EMC\_WE}$ ,  $\overline{EMC\_An}$ ;  $C_L = 9\text{ pF}$  for  $\overline{EMC\_Dn}$ ;  $C_L = 5\text{ pF}$  for  $\overline{EMC\_DQMOUTn}$ ,  $\overline{EMC\_CLKn}$ ,  $\overline{EMC\_CKEOUTn}$ ;  $T_{amb} = -40\text{ }^\circ\text{C}$  to  $85\text{ }^\circ\text{C}$ ;  $2.2\text{ V} \leq V_{DD(REG)(3V3)} \leq 3.6\text{ V}$ ;  $V_{DD(I/O)} = 3.3\text{ V} \pm 10\%$ ;  $RD = 1$  (see LPC43xx User manual);  $\overline{EMC\_CLKn}$  delays  $CLK0\_DELAY = CLK1\_DELAY = CLK2\_DELAY = CLK3\_DELAY = 0$ .

Symbol	Parameter	Min	Typ	Max	Unit
$T_{cy(clk)}$	clock cycle time	8.4	-	-	ns
<b>Common to read and write cycles</b>					
$t_{d(DYCSV)}$	DYCS delay time	-	$3.1 + 0.5 \times T_{cy(clk)}$	$5.1 + 0.5 \times T_{cy(clk)}$	ns
$t_{h(DYCS)}$	DYCS hold time	$0.3 + 0.5 \times T_{cy(clk)}$	$0.9 + 0.5 \times T_{cy(clk)}$	-	ns
$t_{d(RASV)}$	row address strobe valid delay time	-	$3.1 + 0.5 \times T_{cy(clk)}$	$4.9 + 0.5 \times T_{cy(clk)}$	ns
$t_{h(RAS)}$	row address strobe hold time	$0.5 + 0.5 \times T_{cy(clk)}$	$1.1 + 0.5 \times T_{cy(clk)}$	-	ns
$t_{d(CASV)}$	column address strobe valid delay time	-	$2.9 + 0.5 \times T_{cy(clk)}$	$4.6 + 0.5 \times T_{cy(clk)}$	ns
$t_{h(CAS)}$	column address strobe hold time	$0.3 + 0.5 \times T_{cy(clk)}$	$0.9 + 0.5 \times T_{cy(clk)}$	-	ns
$t_{d(WEV)}$	$\overline{WE}$ valid delay time	-	$3.2 + 0.5 \times T_{cy(clk)}$	$5.9 + 0.5 \times T_{cy(clk)}$	ns
$t_{h(WE)}$	$\overline{WE}$ hold time	$1.3 + 0.5 \times T_{cy(clk)}$	$1.4 + 0.5 \times T_{cy(clk)}$	-	ns
$t_{d(DQMOUTV)}$	DQMOUT valid delay time	-	$3.1 + 0.5 \times T_{cy(clk)}$	$5.0 + 0.5 \times T_{cy(clk)}$	ns
$t_{h(DQMOUT)}$	DQMOUT hold time	$0.2 + 0.5 \times T_{cy(clk)}$	$0.8 + 0.5 \times T_{cy(clk)}$	-	ns
$t_{d(AV)}$	address valid delay time	-	$3.8 + 0.5 \times T_{cy(clk)}$	$6.3 + 0.5 \times T_{cy(clk)}$	ns
$t_{h(A)}$	address hold time	$0.3 + 0.5 \times T_{cy(clk)}$	$0.9 + 0.5 \times T_{cy(clk)}$	-	ns
$t_{d(CKEOUTV)}$	CKEOUT valid delay time	-	$3.1 + 0.5 \times T_{cy(clk)}$	$5.1 + 0.5 \times T_{cy(clk)}$	ns
$t_{h(CKEOUT)}$	CKEOUT hold time	$0.5 \times T_{cy(clk)}$	$0.7 + 0.5 \times T_{cy(clk)}$	-	ns
<b>Read cycle parameters</b>					
$t_{su(D)}$	data input set-up time	-1.5	-0.5	-	ns
$t_{h(D)}$	data input hold time	2.2	0.8	-	ns
<b>Write cycle parameters</b>					
$t_{d(QV)}$	data output valid delay time	-	$3.8 + 0.5 \times T_{cy(clk)}$	$6.2 + 0.5 \times T_{cy(clk)}$	ns
$t_{h(Q)}$	data output hold time	$0.5 \times T_{cy(clk)}$	$0.7 + 0.5 \times T_{cy(clk)}$	-	ns

**Table 31. Dynamic characteristics: Dynamic external memory interface; EMC\_CLK[3:0] delay values**

$T_{amb} = -40\text{ }^\circ\text{C}$  to  $85\text{ }^\circ\text{C}$ ;  $V_{DD(I/O)} = 3.3\text{ V} \pm 10\%$ ;  $2.2\text{ V} \leq V_{DD(REG)(3V3)} \leq 3.6\text{ V}$ .

Symbol	Parameter	Conditions	Min	Typ	Max	Unit
$t_d$	delay time	delay value [1]				
		$CLKn\_DELAY = 0$	0.0	0.0	0.0	ns
		$CLKn\_DELAY = 1$ [1]	0.4	0.5	0.8	ns
		$CLKn\_DELAY = 2$ [1]	0.7	1.0	1.7	ns
		$CLKn\_DELAY = 3$ [1]	1.1	1.6	2.5	ns
		$CLKn\_DELAY = 4$ [1]	1.4	2.0	3.3	ns
		$CLKn\_DELAY = 5$ [1]	1.7	2.6	4.1	ns
		$CLKn\_DELAY = 6$ [1]	2.1	3.1	4.9	ns
		$CLKn\_DELAY = 7$ [1]	2.5	3.6	5.8	ns

[1] Program the EMC\_CLKn delay values in the EMCDELAYCLK register (see the LPC43xx User manual). The delay values must be the same for all SDRAM clocks EMC\_CLKn:  $CLK0\_DELAY = CLK1\_DELAY = CLK2\_DELAY = CLK3\_DELAY$ .

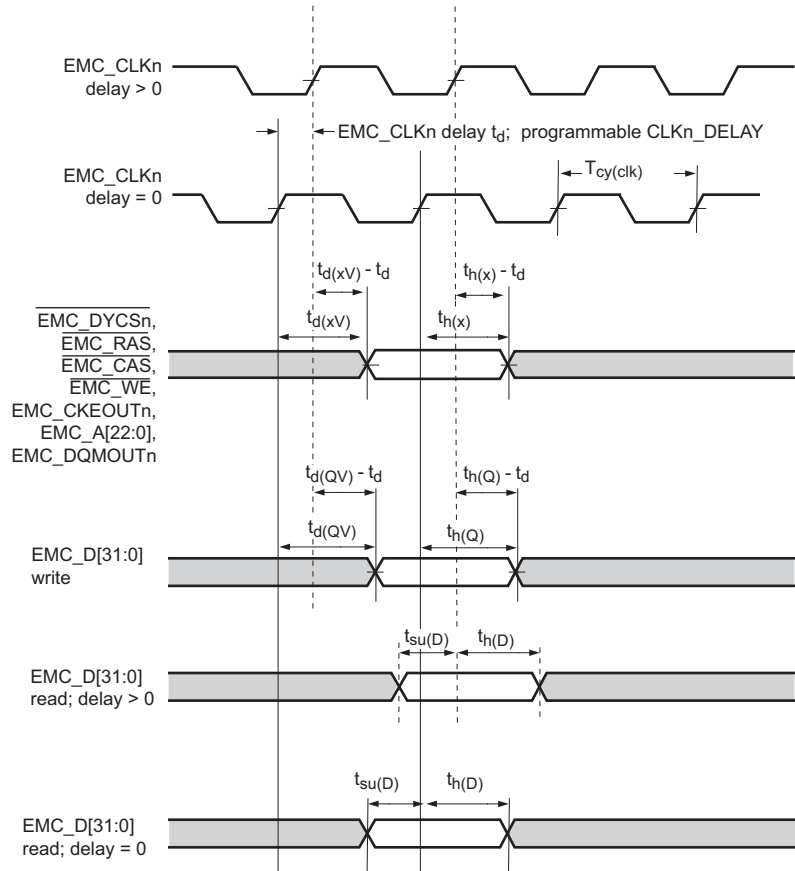

002aag703

For the programmable EMC\_CLK[3:0] clock delays CLKn\_DELAY, see [Table 31](#).

**Remark:** For SDRAM operation, set CLK0\_DELAY = CLK1\_DELAY = CLK2\_DELAY = CLK3\_DELAY in the EMCDELAYCLK register.

Fig 34. SDRAM timing

11.17 USB interface

Table 32. Dynamic characteristics: USB0 and USB1 pins (full-speed)

$C_L = 50\text{ pF}$ ;  $R_{pu} = 1.5\text{ k}\Omega$  on D+ to  $V_{DD(I/O)}$ ;  $3.0\text{ V} \leq V_{DD(I/O)} \leq 3.6\text{ V}$ .

Symbol	Parameter	Conditions	Min	Typ	Max	Unit
$t_r$	rise time	10 % to 90 %	4	-	20	ns
$t_f$	fall time	10 % to 90 %	4	-	20	ns
$t_{FRFM}$	differential rise and fall time matching	$t_r / t_f$	90	-	111.11	%
$V_{CRS}$	output signal crossover voltage		1.3	-	2.0	V
$t_{FEOPT}$	source SE0 interval of EOP	see <a href="#">Figure 35</a>	160	-	175	ns
$t_{FDEOP}$	source jitter for differential transition to SE0 transition	see <a href="#">Figure 35</a>	-2	-	+5	ns
$t_{JR1}$	receiver jitter to next transition		-18.5	-	+18.5	ns
$t_{JR2}$	receiver jitter for paired transitions	10 % to 90 %	-9	-	+9	ns
$t_{EOPR1}$	EOP width at receiver	must reject as EOP; see <a href="#">Figure 35</a>	[1] 40	-	-	ns
$t_{EOPR2}$	EOP width at receiver	must accept as EOP; see <a href="#">Figure 35</a>	[1] 82	-	-	ns

[1] Characterized but not implemented as production test. Guaranteed by design.

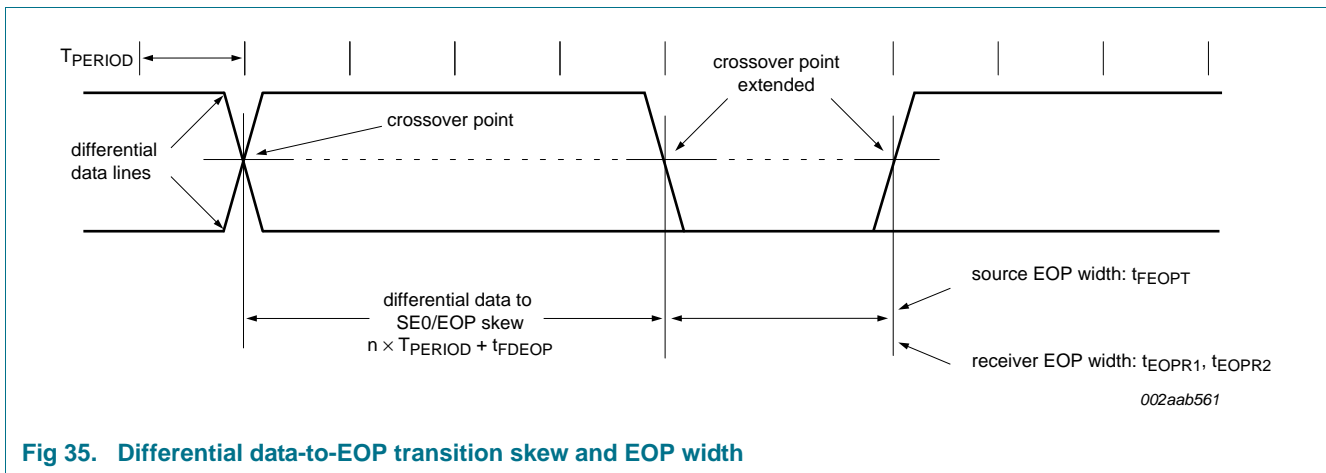

Fig 35. Differential data-to-EOP transition skew and EOP width

Table 33. Static characteristics: USB0 PHY pins<sup>[1]</sup>

Symbol	Parameter	Conditions	Min	Typ	Max	Unit
<b>High-speed mode</b>						
P <sub>cons</sub>	power consumption		[2] -	68	-	mW
I <sub>DDA(3V3)</sub>	analog supply current (3.3 V)	on pin USB0_VDDA3V3_DRIVER;	[3]			
	total supply current		-	18	-	mA
	during transmit		-	31	-	mA
	during receive		-	14	-	mA
	with driver tri-stated		-	14	-	mA
I <sub>DDD</sub>	digital supply current		-	7	-	mA
<b>Full-speed/low-speed mode</b>						
P <sub>cons</sub>	power consumption		[2] -	15	-	mW
I <sub>DDA(3V3)</sub>	analog supply current (3.3 V)	on pin USB0_VDDA3V3_DRIVER;				
	total supply current		-	3.5	-	mA
	during transmit		-	5	-	mA
	during receive		-	3	-	mA
	with driver tri-stated		-	3	-	mA
I <sub>DDD</sub>	digital supply current		-	3	-	mA
<b>Suspend mode</b>						
I <sub>DDA(3V3)</sub>	analog supply current (3.3 V)		-	24	-	μA
	with driver tri-stated		-	24	-	μA
	with OTG functionality enabled		-	3	-	mA
I <sub>DDD</sub>	digital supply current		-	30	-	μA
<b>VBUS detector outputs</b>						
V <sub>th</sub>	threshold voltage	for VBUS valid	4.4	-	-	V
		for session end	0.2	-	0.8	V
		for A valid	0.8	-	2	V
		for B valid	2	-	4	V
V <sub>hys</sub>	hysteresis voltage	for session end	-	150	10	mV
		A valid	-	200	10	mV
		B valid	-	200	10	mV

[1] Characterized but not implemented as production test.

[2] Total average power consumption.

[3] The driver is active only 20 % of the time.

## 11.18 Ethernet

**Remark:** The timing characteristics of the ENET\_MDC and ENET\_MDIO signals comply with the *IEEE standard 802.3*.

**Table 34. Dynamic characteristics: Ethernet**

$T_{amb} = -40\text{ }^{\circ}\text{C}$  to  $85\text{ }^{\circ}\text{C}$ ;  $2.2\text{ V} \leq V_{DD(REG)(3V3)} \leq 3.6\text{ V}$ ;  $2.7\text{ V} \leq V_{DD(I/O)} \leq 3.6\text{ V}$ . Values guaranteed by design.

Symbol	Parameter	Conditions	Min	Max	Unit
<b>RMII mode</b>					
$f_{clk}$	clock frequency	for ENET_RX_CLK	[1]	-	50 MHz
$\delta_{clk}$	clock duty cycle		[1]	50	%
$t_{su}$	set-up time	for ENET_TXDn, ENET_TX_EN, ENET_RXDn, ENET_RX_ER, ENET_RX_DV	[1][2]	4	- ns
$t_h$	hold time	for ENET_TXDn, ENET_TX_EN, ENET_RXDn, ENET_RX_ER, ENET_RX_DV	[1][2]	2	- ns
<b>MII mode</b>					
$f_{clk}$	clock frequency	for ENET_TX_CLK	[1]	-	25 MHz
$\delta_{clk}$	clock duty cycle		[1]	50	%
$t_{su}$	set-up time	for ENET_TXDn, ENET_TX_EN, ENET_TX_ER	[1][2]	4	- ns
$t_h$	hold time	for ENET_TXDn, ENET_TX_EN, ENET_TX_ER	[1][2]	2	- ns
$f_{clk}$	clock frequency	for ENET_RX_CLK	[1]	-	25 MHz
$\delta_{clk}$	clock duty cycle		[1]	50	%
$t_{su}$	set-up time	for ENET_RXDn, ENET_RX_ER, ENET_RX_DV	[1][2]	4	- ns
$t_h$	hold time	for ENET_RXDn, ENET_RX_ER, ENET_RX_DV	[1][2]	2	- ns

[1] Output drivers can drive a load  $\geq 25\text{ pF}$  accommodating over 12 inch of PCB trace and the input capacitance of the receiving device.

[2] Timing values are given from the point at which the clock signal waveform crosses 1.4 V to the valid input or output level.

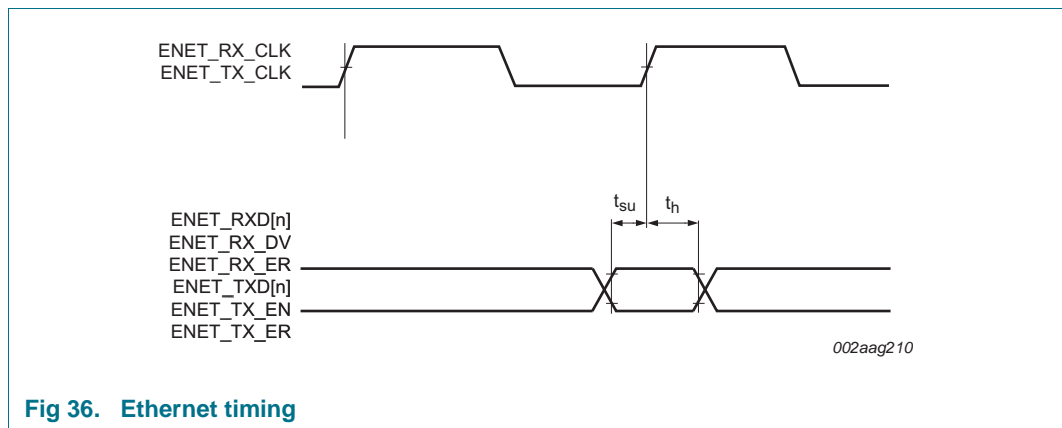

**Fig 36. Ethernet timing**

11.19 SD/MMC

**Table 35. Dynamic characteristics: SD/MMC**

$T_{amb} = -40\text{ }^{\circ}\text{C}$  to  $85\text{ }^{\circ}\text{C}$ ,  $2.2\text{ V} \leq V_{DD(REG)(3V3)} \leq 3.6\text{ V}$ ;  $2.7\text{ V} \leq V_{DD(I/O)} \leq 3.6\text{ V}$ ,  $C_L = 20\text{ pF}$ .  
 $SAMPLE\_DELAY = 0x9$ ,  $DRV\_DELAY = 0xD$  in the  $SDDELAY$  register sampled at 90 % and 10 % of the signal level,  $EHS = 1$  for  $SD\_CLK$  pin,  $EHS = 1$  for  $SD\_DATn$  and  $SD\_CMD$  pins. Simulated values.

Symbol	Parameter	Conditions	Min	Max	Unit
$f_{clk}$	clock frequency	on pin $SD\_CLK$ ; data transfer mode		52	MHz
$t_{su(D)}$	data input set-up time	on pins $SD\_DATn$ as inputs	3.9	-	ns
		on pins $SD\_CMD$ as inputs	5.2	-	ns
$t_{h(D)}$	data input hold time	on pins $SD\_DATn$ as inputs	0.4	-	ns
		on pins $SD\_CMD$ as inputs	0		ns
$t_{d(QV)}$	data output valid delay time	on pins $SD\_DATn$ as outputs	-	15.3	ns
		on pins $SD\_CMD$ as outputs	-	16	ns
$t_{h(Q)}$	data output hold time	on pins $SD\_DATn$ as outputs	4	-	ns
		on pins $SD\_CMD$ as outputs	4	-	ns

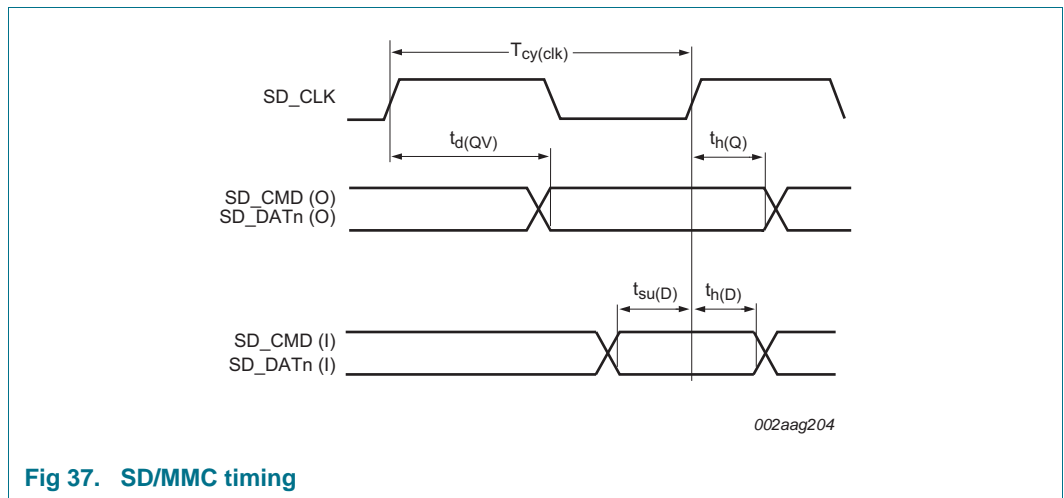

Fig 37. SD/MMC timing

11.20 LCD

**Table 36. Dynamic characteristics: LCD**

$T_{amb} = 25\text{ }^{\circ}\text{C}$ ;  $2.2\text{ V} \leq V_{DD(REG)(3V3)} \leq 3.6\text{ V}$ ;  $2.7\text{ V} \leq V_{DD(I/O)} \leq 3.6\text{ V}$ ;  $C_L = 20\text{ pF}$ . Simulated values.

Symbol	Parameter	Conditions	Min	Typ	Max	Unit
$f_{clk}$	clock frequency	on pin $LCD\_DCLK$	-	50	-	MHz
$t_{d(QV)}$	data output valid delay time		-		17	ns
$t_{h(Q)}$	data output hold time		8.5	-		ns

## 12. ADC/DAC electrical characteristics

**Table 37. 12-bit ADC characteristics**

$V_{DDA(3V3)}$  over specified ranges;  $T_{amb} = -40\text{ °C}$  to  $+85\text{ °C}$ ; unless otherwise specified.

Symbol	Parameter	Conditions	Min	Typ	Max	Unit
$V_{DC}$	DC input common mode level		0.1	0.5	0.9	V
$C_{in}$	input capacitance	single ended	-	4.5	-	pF
$R_i$	input resistance	single ended; per selected positive or negative input pin	-	5	-	k $\Omega$
$V_{i(range)}$	input voltage range	differential, peak-to-peak	0.72	0.8	0.88	V
$f_{c(ADC)}$	ADC conversion frequency	12-bit resolution	-	-	80	MSamples/s
<b><math>f_{c(ADC)} = 10\text{ Msamples/s}</math>; <math>f_{in} = 1\text{ MHz}</math>; bias current bits CRS[3:0] = 0000<sup>[1]</sup></b>						
INL	integral non-linearity		-	$\pm 1.1$	-	LSB
DNL	differential non-linearity		-	$\pm 0.7$	-	LSB
ENOB	effective number of bits		-	10.4	-	-
SNR	signal-to-noise ratio		-	64.0	-	dB
THD	total harmonic distortion		-	-73	-	dB
SFDR	spurious free dynamic range		-	80	-	dB
HD2	second harmonic distortion		-	-84	-	dB
HD3	third harmonic distortion		-	-75	-	dB
<b><math>f_{c(ADC)} = 60\text{ Msamples/s}</math>; <math>f_{in} = 1\text{ MHz}</math>; bias current bits CRS[3:0] = 0011<sup>[1]</sup></b>						
INL	integral non-linearity		-	$\pm 1.2$	-	LSB
DNL	differential non-linearity		-	$\pm 0.7$	-	LSB
ENOB	effective number of bits		-	10.1	-	-
SNR	signal-to-noise ratio		-	63	-	dB
THD	total harmonic distortion		-	-72	-	dB
SFDR	spurious free dynamic range		-	75	-	dB
HD2	second harmonic distortion		-	-79	-	dB
HD3	third harmonic distortion		-	-75	-	dB

[1]  $f_{in}$  = signal input frequency. The bias current is programmable. Higher bias current allows for a higher ADC conversion frequency at higher power consumption.

**Table 38. 10-bit ADC characteristics**

$V_{DDA(3V3)}$  over specified ranges;  $T_{amb} = -40\text{ °C}$  to  $+85\text{ °C}$ ; unless otherwise specified.

Symbol	Parameter	Conditions	Min	Typ	Max	Unit	
$V_{IA}$	analog input voltage		0	-	$V_{DDA(3V3)}$	V	
$C_{ia}$	analog input capacitance		-	-	2	pF	
$E_D$	differential linearity error	$2.7\text{ V} \leq V_{DDA(3V3)} \leq 3.6\text{ V}$	[1][2]	-	$\pm 0.8$	-	LSB
		$2.2\text{ V} \leq V_{DDA(3V3)} < 2.7\text{ V}$	-	-	$\pm 1.0$	-	LSB
$E_{L(adj)}$	integral non-linearity	$2.7\text{ V} \leq V_{DDA(3V3)} \leq 3.6\text{ V}$	[3]	-	$\pm 0.8$	-	LSB
		$2.2\text{ V} \leq V_{DDA(3V3)} < 2.7\text{ V}$	-	-	$\pm 1.5$	-	LSB
$E_O$	offset error	$2.7\text{ V} \leq V_{DDA(3V3)} \leq 3.6\text{ V}$	[4]	-	$\pm 0.15$	-	LSB
		$2.2\text{ V} \leq V_{DDA(3V3)} < 2.7\text{ V}$	-	-	$\pm 0.15$	-	LSB
$E_G$	gain error	$2.7\text{ V} \leq V_{DDA(3V3)} \leq 3.6\text{ V}$	[5]	-	$\pm 0.3$	-	%
		$2.2\text{ V} \leq V_{DDA(3V3)} < 2.7\text{ V}$	-	-	$\pm 0.35$	-	%
$E_T$	absolute error	$2.7\text{ V} \leq V_{DDA(3V3)} \leq 3.6\text{ V}$	[6]	-	$\pm 3$	-	LSB
		$2.7\text{ V} \leq V_{DDA(3V3)} \leq 3.6\text{ V}$	-	-	$\pm 4$	-	LSB
$R_{vsi}$	voltage source interface resistance	see <a href="#">Figure 39</a>	-	-	$1/(7 \times f_{clk(ADC)} \times C_{ia})$	k $\Omega$	
$R_i$	input resistance		[7][8]	-	-	1.2	M $\Omega$
$f_{clk(ADC)}$	ADC clock frequency		-	-	4.5	MHz	
$f_{c(ADC)}$	ADC conversion frequency	10-bit resolution; 11 clock cycles	-	-	400	kSamples/s	
		2-bit resolution; 3 clock cycles	-	-	1.5	MSamples/s	

- [1] The ADC is monotonic, there are no missing codes.
- [2] The differential linearity error ( $E_D$ ) is the difference between the actual step width and the ideal step width. See [Figure 38](#).
- [3] The integral non-linearity ( $E_{L(adj)}$ ) is the peak difference between the center of the steps of the actual and the ideal transfer curve after appropriate adjustment of gain and offset errors. See [Figure 38](#).
- [4] The offset error ( $E_O$ ) is the absolute difference between the straight line which fits the actual curve and the straight line which fits the ideal curve. See [Figure 38](#).
- [5] The gain error ( $E_G$ ) is the relative difference in percent between the straight line fitting the actual transfer curve after removing offset error, and the straight line which fits the ideal transfer curve. See [Figure 38](#).
- [6] The absolute error ( $E_T$ ) is the maximum difference between the center of the steps of the actual transfer curve of the non-calibrated ADC and the ideal transfer curve. See [Figure 38](#).
- [7]  $T_{amb} = 25\text{ °C}$ ; maximum sampling frequency  $f_s = 4.5\text{ MHz}$  and analog input capacitance  $C_{ia} = 2\text{ pF}$ .
- [8] Input resistance  $R_i$  depends on the sampling frequency  $f_s$ :  $R_i = 2\text{ k}\Omega + 1 / (f_s \times C_{ia})$ .

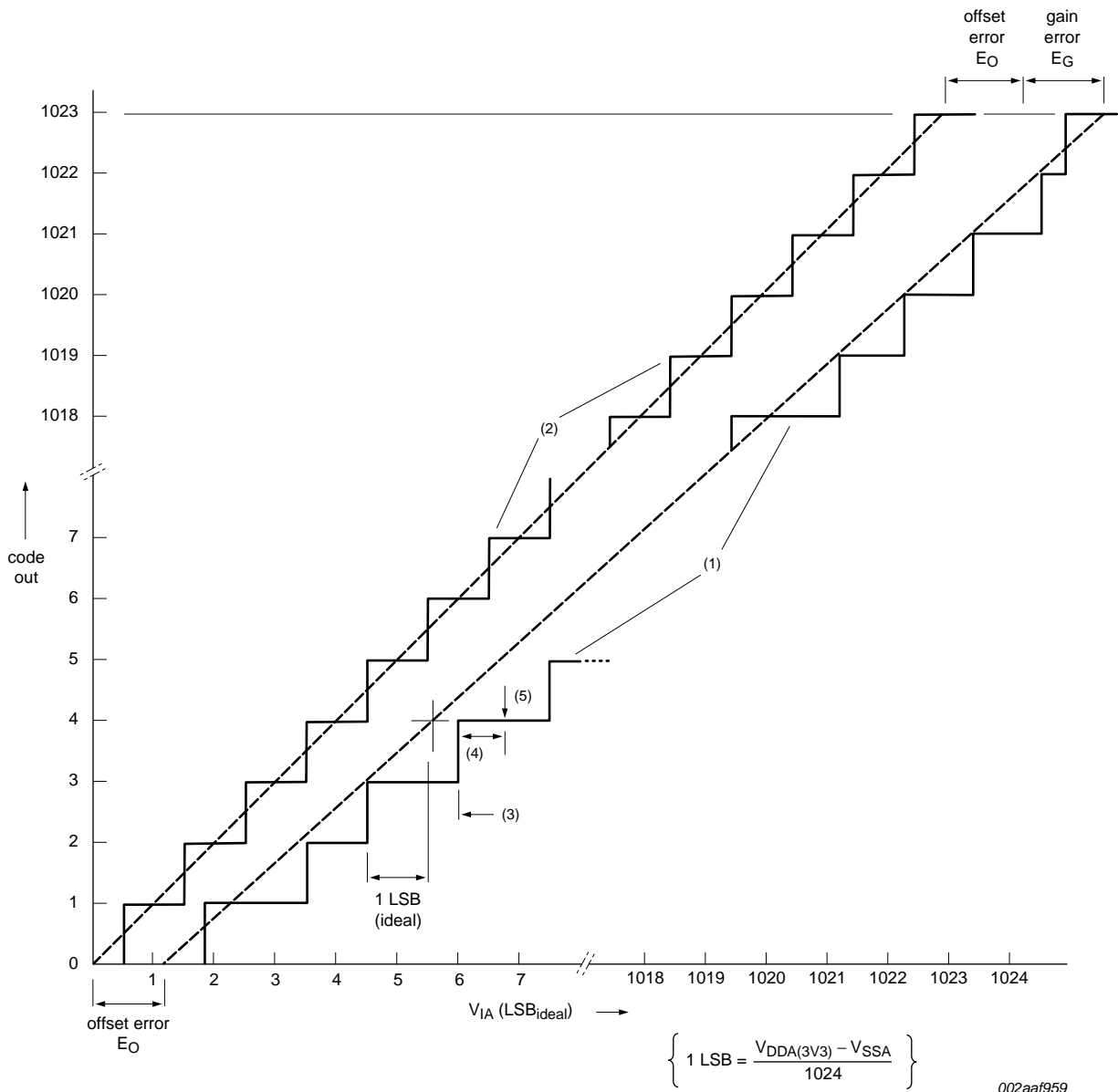

- (1) Example of an actual transfer curve.
- (2) The ideal transfer curve.
- (3) Differential linearity error ( $E_D$ ).
- (4) Integral non-linearity ( $E_{L(adj)}$ ).
- (5) Center of a step of the actual transfer curve.
- (6)  $V_{DDA}$  refers to  $V_{DDA(3V3)}$  on pin VDDA and  $V_{SSA}$  to analog ground on pin VSSA.

**Fig 38. 10-bit ADC characteristics**

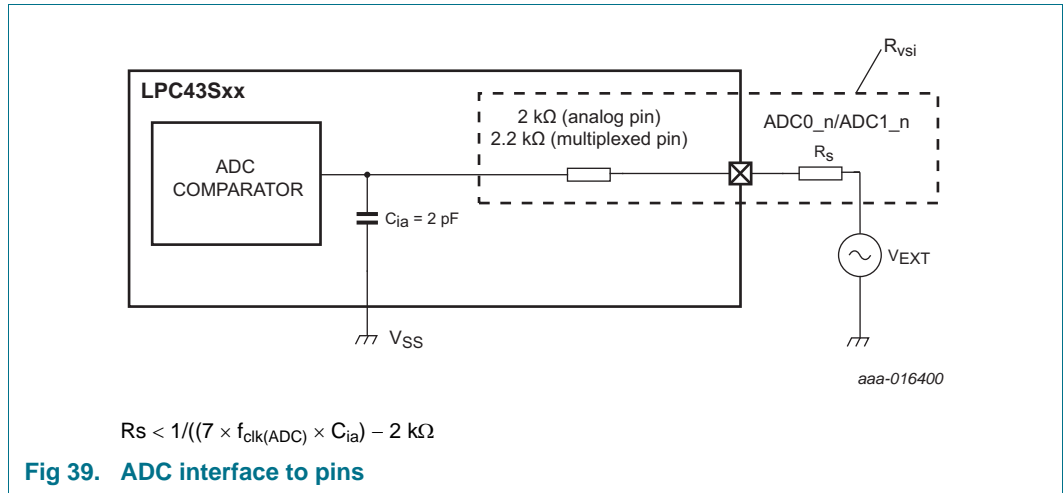

**Table 39. DAC characteristics**

$V_{DDA(3V3)}$  over specified ranges;  $T_{amb} = -40\text{ }^\circ\text{C}$  to  $+85\text{ }^\circ\text{C}$ ; unless otherwise specified

Symbol	Parameter	Conditions	Min	Typ	Max	Unit	
$E_D$	differential linearity error	$2.7 \text{ V} \leq V_{DDA(3V3)} \leq 3.6 \text{ V}$	[1]	-	$\pm 0.8$	-	LSB
		$2.2 \text{ V} \leq V_{DDA(3V3)} < 2.7 \text{ V}$	-	-	$\pm 1.0$	-	LSB
$E_{L(adj)}$	integral non-linearity	code = 0 to 975	[1]	-	$\pm 1.0$	-	LSB
		$2.7 \text{ V} \leq V_{DDA(3V3)} \leq 3.6 \text{ V}$	-	-	$\pm 1.5$	-	LSB
$E_O$	offset error	$2.7 \text{ V} \leq V_{DDA(3V3)} \leq 3.6 \text{ V}$	[1]	-	$\pm 0.8$	-	LSB
		$2.2 \text{ V} \leq V_{DDA(3V3)} < 2.7 \text{ V}$	-	-	$\pm 1.0$	-	LSB
$E_G$	gain error	$2.7 \text{ V} \leq V_{DDA(3V3)} \leq 3.6 \text{ V}$	[1]	-	$\pm 0.3$	-	%
		$2.2 \text{ V} \leq V_{DDA(3V3)} < 2.7 \text{ V}$	-	-	$\pm 1.0$	-	%
$C_L$	load capacitance		-	-	200	pF	
$R_L$	load resistance		1	-	-	kΩ	
$t_s$	settling time		[1]	0.4	-	μs	

[1] In the DAC CR register, bit BIAS = 0 (see the *LPC43xx user manual*).

[2] Settling time is calculated within 1/2 LSB of the final value.

## 13. Application information

### 13.1 LCD panel signal usage

Table 40. LCD panel connections for STN single panel mode

External pin	4-bit mono STN single panel		8-bit mono STN single panel		Color STN single panel	
	LPC43xx pin used	LCD function	LPC43xx pin used	LCD function	LPC43xx pin used	LCD function
LCD_VD[23:8]	-	-	-	-	-	-
LCD_VD7	-	-	P8_4	UD[7]	P8_4	UD[7]
LCD_VD6	-	-	P8_5	UD[6]	P8_5	UD[6]
LCD_VD5	-	-	P8_6	UD[5]	P8_6	UD[5]
LCD_VD4	-	-	P8_7	UD[4]	P8_7	UD[4]
LCD_VD3	P4_2	UD[3]	P4_2	UD[3]	P4_2	UD[3]
LCD_VD2	P4_3	UD[2]	P4_3	UD[2]	P4_3	UD[2]
LCD_VD1	P4_4	UD[1]	P4_4	UD[1]	P4_4	UD[1]
LCD_VD0	P4_1	UD[0]	P4_1	UD[0]	P4_1	UD[0]
LCD_LP	P7_6	LCDLP	P7_6	LCDLP	P7_6	LCDLP
LCD_ENAB/ LCDM	P4_6	LCDENAB/ LCDM	P4_6	LCDENAB/ LCDM	P4_6	LCDENAB/ LCDM
LCD_FP	P4_5	LCDFP	P4_5	LCDFP	P4_5	LCDFP
LCD_DCLK	P4_7	LCDDCLK	P4_7	LCDDCLK	P4_7	LCDDCLK
LCD_LE	P7_0	LCDLE	P7_0	LCDLE	P7_0	LCDLE
LCD_PWR	P7_7	CDPWR	P7_7	LCDPWR	P7_7	LCDPWR
GP_CLKIN	PF_4	LCDCLKIN	PF_4	LCDCLKIN	PF_4	LCDCLKIN

Table 41. LCD panel connections for STN dual panel mode

External pin	4-bit mono STN dual panel		8-bit mono STN dual panel		Color STN dual panel	
	LPC43xx pin used	LCD function	LPC43xx pin used	LCD function	LPC43xx pin used	LCD function
LCD_VD[23:16]	-	-	-	-	-	-
LCD_VD15	-	-	PB_4	LD[7]	PB_4	LD[7]
LCD_VD14	-	-	PB_5	LD[6]	PB_5	LD[6]
LCD_VD13	-	-	PB_6	LD[5]	PB_6	LD[5]
LCD_VD12	-	-	P8_3	LD[4]	P8_3	LD[4]
LCD_VD11	P4_9	LD[3]	P4_9	LD[3]	P4_9	LD[3]
LCD_VD10	P4_10	LD[2]	P4_10	LD[2]	P4_10	LD[2]
LCD_VD9	P4_8	LD[1]	P4_8	LD[1]	P4_8	LD[1]
LCD_VD8	P7_5	LD[0]	P7_5	LD[0]	P7_5	LD[0]
LCD_VD7	-	-		UD[7]	P8_4	UD[7]
LCD_VD6	-	-	P8_5	UD[6]	P8_5	UD[6]
LCD_VD5	-	-	P8_6	UD[5]	P8_6	UD[5]
LCD_VD4	-	-	P8_7	UD[4]	P8_7	UD[4]
LCD_VD3	P4_2	UD[3]	P4_2	UD[3]	P4_2	UD[3]

Table 41. LCD panel connections for STN dual panel mode

External pin	4-bit mono STN dual panel		8-bit mono STN dual panel		Color STN dual panel	
	LPC43xx pin used	LCD function	LPC43xx pin used	LCD function	LPC43xx pin used	LCD function
LCD_VD2	P4_3	UD[2]	P4_3	UD[2]	P4_3	UD[2]
LCD_VD1	P4_4	UD[1]	P4_4	UD[1]	P4_4	UD[1]
LCD_VD0	P4_1	UD[0]	P4_1	UD[0]	P4_1	UD[0]
LCD_LP	P7_6	LCDLP	P7_6	LCDLP	P7_6	LCDLP
LCD_ENAB/ LCDM	P4_6	LCDENAB/ LCDM	P4_6	LCDENAB/ LCDM	P4_6	LCDENAB/ LCDM
LCD_FP	P4_5	LCDFP	P4_5	LCDFP	P4_5	LCDFP
LCD_DCLK	P4_7	LCDDCLK	P4_7	LCDDCLK	P4_7	LCDDCLK
LCD_LE	P7_0	LCDLE	P7_0	LCDLE	P7_0	LCDLE
LCD_PWR	P7_7	LCDPWR	P7_7	LCDPWR	P7_7	LCDPWR
GP_CLKIN	PF_4	LCDCLKIN	PF_4	LCDCLKIN	PF_4	LCDCLKIN

Table 42. LCD panel connections for TFT panels

External pin	TFT 12 bit (4:4:4 mode)		TFT 16 bit (5:6:5 mode)		TFT 16 bit (1:5:5:5 mode)		TFT 24 bit	
	LPC43xx pin used	LCD function	LPC43xx pin used	LCD function	LPC43xx pin used	LCD function	LPC43xx pin used	LCD function
LCD_VD23	PB_0	BLUE3	PB_0	BLUE4	PB_0	BLUE4	PB_0	BLUE7
LCD_VD22	PB_1	BLUE2	PB_1	BLUE3	PB_1	BLUE3	PB_1	BLUE6
LCD_VD21	PB_2	BLUE1	PB_2	BLUE2	PB_2	BLUE2	PB_2	BLUE5
LCD_VD20	PB_3	BLUE0	PB_3	BLUE1	PB_3	BLUE1	PB_3	BLUE4
LCD_VD19	-	-	P7_1	BLUE0	P7_1	BLUE0	P7_1	BLUE3
LCD_VD18	-	-	-	-	P7_2	intensity	P7_2	BLUE2
LCD_VD17	-	-	-	-	-	-	P7_3	BLUE1
LCD_VD16	-	-	-	-	-	-	P7_4	BLUE0
LCD_VD15	PB_4	GREEN3	PB_4	GREEN5	PB_4	GREEN4	PB_4	GREEN7
LCD_VD14	PB_5	GREEN2	PB_5	GREEN4	PB_5	GREEN3	PB_5	GREEN6
LCD_VD13	PB_6	GREEN1	PB_6	GREEN3	PB_6	GREEN2	PB_6	GREEN5
LCD_VD12	P8_3	GREEN0	P8_3	GREEN2	P8_3	GREEN1	P8_3	GREEN4
LCD_VD11	-	-	P4_9	GREEN1	P4_9	GREEN0	P4_9	GREEN3
LCD_VD10	-	-	P4_10	GREEN0	P4_10	intensity	P4_10	GREEN2
LCD_VD9	-	-	-	-	-	-	P4_8	GREEN1
LCD_VD8	-	-	-	-	-	-	P7_5	GREEN0
LCD_VD7	P8_4	RED3	P8_4	RED4	P8_4	RED4	P8_4	RED7
LCD_VD6	P8_5	RED2	P8_5	RED3	P8_5	RED3	P8_5	RED6
LCD_VD5	P8_6	RED1	P8_6	RED2	P8_6	RED2	P8_6	RED5
LCD_VD4	P8_7	RED0	P8_7	RED1	P8_7	RED1	P8_7	RED4
LCD_VD3	-	-	P4_2	RED0	P4_2	RED0	P4_2	RED3
LCD_VD2	-	-	-	-	P4_3	intensity	P4_3	RED2
LCD_VD1	-	-	-	-	-	-	P4_4	RED1

Table 42. LCD panel connections for TFT panels

External pin	TFT 12 bit (4:4:4 mode)		TFT 16 bit (5:6:5 mode)		TFT 16 bit (1:5:5:5 mode)		TFT 24 bit	
	LPC43xx pin used	LCD function	LPC43xx pin used	LCD function	LPC43xx pin used	LCD function	LPC43xx pin used	LCD function
LCD_VD0	-	-	-	-	-	-	P4_1	RED0
LCD_LP	P7_6	LCDLP	P7_6	LCDLP	P7_6	LCDLP	P7_6	LCDLP
LCD_ENAB /LCDM	P4_6	LCDENAB/LCDM	P4_6	LCDENAB/LCDM	P4_6	LCDENAB/LCDM	P4_6	LCDENAB/LCDM
LCD_FP	P4_5	LCDFP	P4_5	LCDFP	P4_5	LCDFP	P4_5	LCDFP
LCD_DCLK	P4_7	LCDDCLK	P4_7	LCDDCLK	P4_7	LCDDCLK	P4_7	LCDDCLK
LCD_LE	P7_0	LCDLE	P7_0	LCDLE	P7_0	LCDLE	P7_0	LCDLE
LCD_PWR	P7_7	LCDPWR	P7_7	LCDPWR	P7_7	LCDPWR	P7_7	LCDPWR
GP_CLKIN	PF_4	LCDCLKIN	PF_4	LCDCLKIN	PF_4	LCDCLKIN	PF_4	LCDCLKIN

### 13.2 Crystal oscillator

The crystal oscillator is controlled by the XTAL\_OSC\_CTRL register in the CGU (see *LPC43xx user manual*).

The crystal oscillator operates at frequencies of 1 MHz to 25 MHz. This frequency can be boosted to a higher frequency, up to the maximum CPU operating frequency, by the PLL. The oscillator can operate in one of two modes: slave mode and oscillation mode.

- In slave mode the input clock signal should be coupled by means of a capacitor of 100 pF ( $C_C$  in [Figure 40](#)), with an amplitude of at least 200 mV (rms). The XTAL2 pin in this configuration can be left unconnected.
- External components and models used in oscillation mode are shown in [Figure 41](#), and in [Table 43](#) and [Table 44](#). Since the feedback resistance is integrated on chip, only a crystal and the capacitances  $C_{X1}$  and  $C_{X2}$  need to be connected externally in case of fundamental mode oscillation (the fundamental frequency is represented by  $L$ ,  $C_L$  and  $R_s$ ). Capacitance  $C_P$  in [Figure 41](#) represents the parallel package capacitance and should not be larger than 7 pF. Parameters  $F_C$ ,  $C_L$ ,  $R_s$  and  $C_P$  are supplied by the crystal manufacturer.

Table 43. Recommended values for  $C_{X1/X2}$  in oscillation mode (crystal and external components parameters) low frequency mode

Fundamental oscillation frequency	Maximum crystal series resistance $R_s$	External load capacitors $C_{X1}$ , $C_{X2}$
2 MHz	< 200 $\Omega$	33 pF, 33 pF
	< 200 $\Omega$	39 pF, 39 pF
	< 200 $\Omega$	56 pF, 56 pF
4 MHz	< 200 $\Omega$	18 pF, 18 pF
	< 200 $\Omega$	39 pF, 39 pF
	< 200 $\Omega$	56 pF, 56 pF
8 MHz	< 200 $\Omega$	18 pF, 18 pF
	< 200 $\Omega$	39 pF, 39 pF

**Table 43. Recommended values for  $C_{X1/X2}$  in oscillation mode (crystal and external components parameters) low frequency mode**

Fundamental oscillation frequency	Maximum crystal series resistance $R_S$	External load capacitors $C_{X1}, C_{X2}$
12 MHz	$< 160 \Omega$	18 pF, 18 pF
	$< 160 \Omega$	39 pF, 39 pF
16 MHz	$< 120 \Omega$	18 pF, 18 pF
	$< 80 \Omega$	33 pF, 33 pF
20 MHz	$< 100 \Omega$	18 pF, 18 pF
	$< 80 \Omega$	33 pF, 33 pF

**Table 44. Recommended values for  $C_{X1/X2}$  in oscillation mode (crystal and external components parameters) high frequency mode**

Fundamental oscillation frequency	Maximum crystal series resistance $R_S$	External load capacitors $C_{X1}, C_{X2}$
15 MHz	$< 80 \Omega$	18 pF, 18 pF
20 MHz	$< 80 \Omega$	39 pF, 39 pF
	$< 100 \Omega$	47 pF, 47 pF

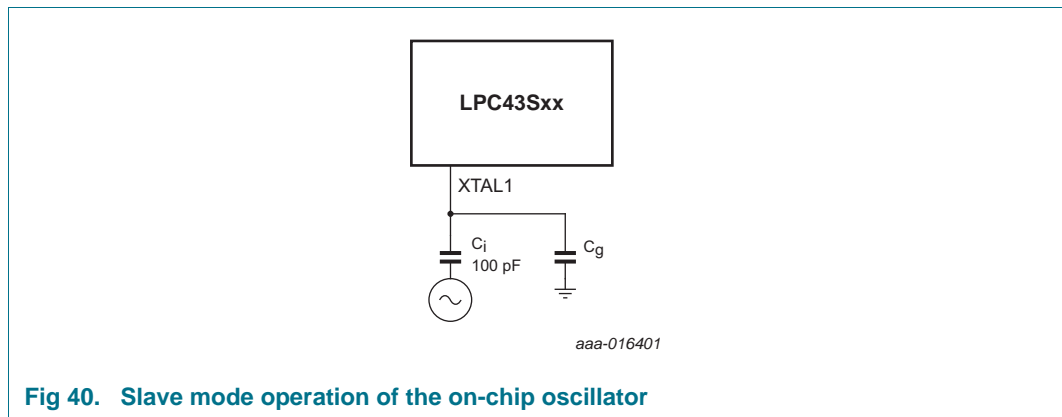

**Fig 40. Slave mode operation of the on-chip oscillator**

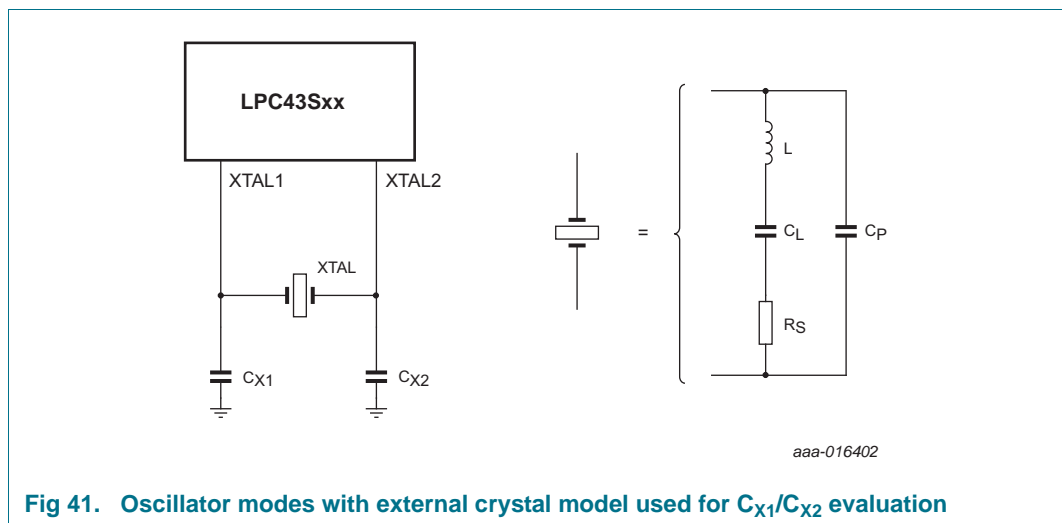

**Fig 41. Oscillator modes with external crystal model used for  $C_{X1}/C_{X2}$  evaluation**

### 13.3 RTC oscillator

In the RTC oscillator circuit, only the crystal (XTAL) and the capacitances  $C_{RTCX1}$  and  $C_{RTCX2}$  need to be connected externally. Typical capacitance values for  $C_{RTCX1}$  and  $C_{RTCX2}$  are  $C_{RTCX1/2} = 20$  (typical)  $\pm 4$  pF.

An external clock can be connected to RTCX1 if RTCX2 is left open. The recommended amplitude of the clock signal is  $V_{i(RMS)} = 100$  mV to 200 mV with a coupling capacitance of 5 pF to 10 pF.  $V_{i(RMS)}$  must be lower than 450 mV. See [Figure 40](#) for a similar slave-mode set-up that uses the crystal oscillator.

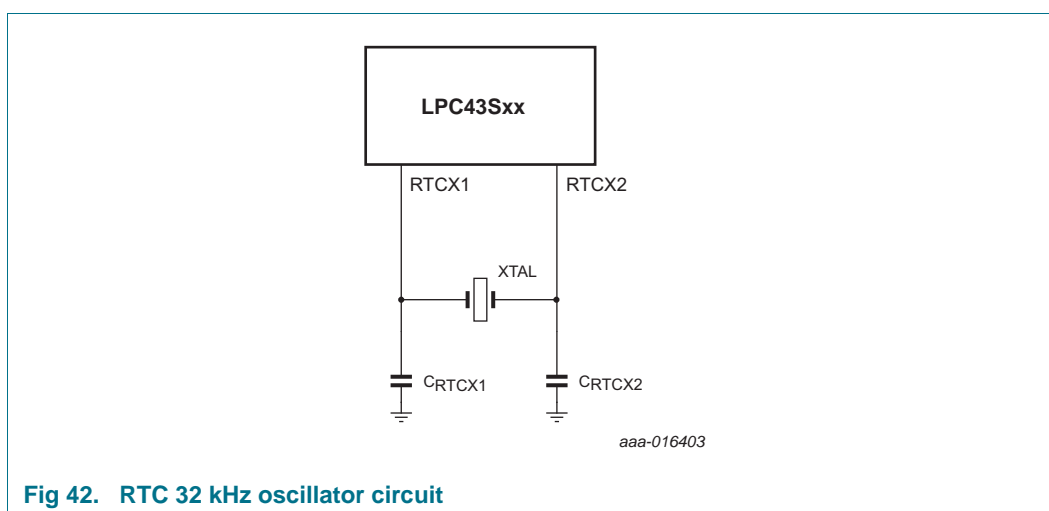

Fig 42. RTC 32 kHz oscillator circuit

### 13.4 XTAL and RTCX Printed Circuit Board (PCB) layout guidelines

Connect the crystal on the PCB as close as possible to the oscillator input and output pins of the chip. Take care that the load capacitors  $C_{x1}$ ,  $C_{x2}$ , and  $C_{x3}$  in case of third overtone crystal usage have a common ground plane. Also connect the external components to the ground plain. To keep the noise coupled in via the PCB as small as possible, make loops and parasitics as small as possible. Choose smaller values of  $C_{x1}$  and  $C_{x2}$  if parasitics increase in the PCB layout.

### 13.5 Standard I/O pin configuration

[Figure 43](#) shows the possible pin modes for standard I/O pins with analog input function:

- Digital output driver enabled/disabled
- Digital input: Pull-up enabled/disabled
- Digital input: Pull-down enabled/disabled
- Digital input: Repeater mode enabled/disabled
- Digital input: Input buffer enabled/disabled
- Analog input

The default configuration for standard I/O pins is input with pull-up enabled. The weak MOS devices provide a drive capability equivalent to pull-up and pull-down resistors.

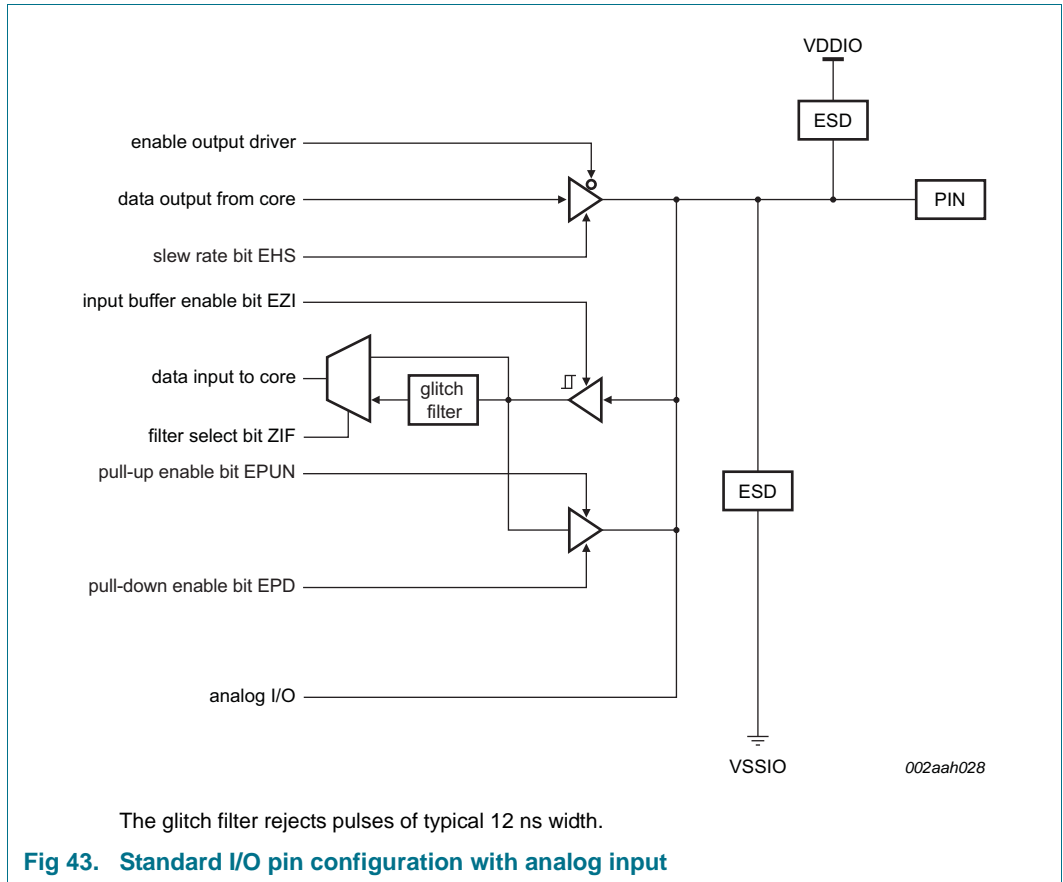

### 13.6 Reset pin configuration

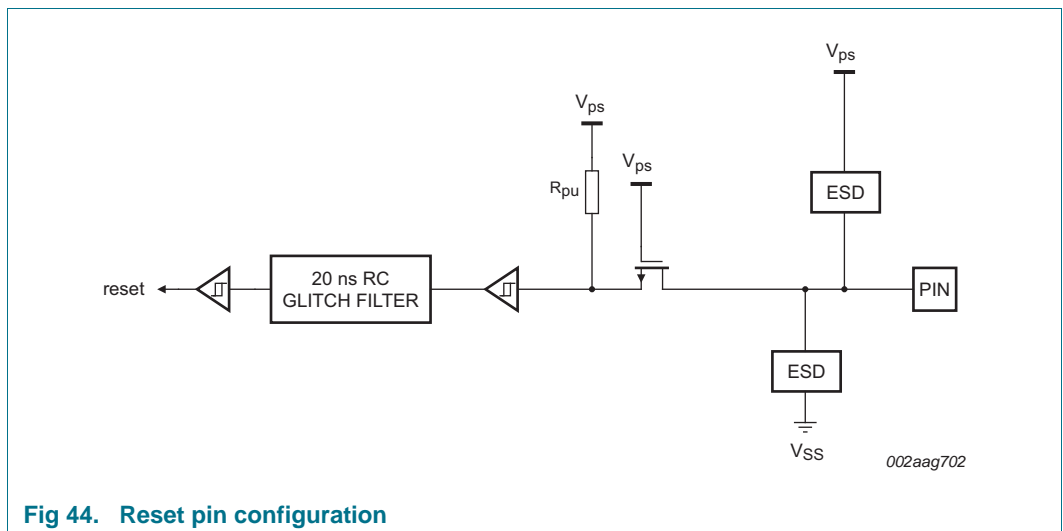

### 13.7 Suggested USB interface solutions

The USB device can be connected to the USB as self-powered device (see [Figure 45](#)) or bus-powered device (see [Figure 46](#)).

On the LPC43S70, USBn\_VBUS pins are 5 V tolerant only when VDDIO is applied and at operating voltage level. Therefore, if the USBn\_VBUS function is connected to the USB connector and the device is self-powered, the USBn\_VBUS pins must be protected for situations when VDDIO = 0 V.

If VDDIO is always at operating level while VBUS = 5 V, the USBn\_VBUS pin can be connected directly to the VBUS pin on the USB connector.

For systems where VDDIO can be 0 V and VBUS is directly applied to the USBn\_VBUS pins, precautions must be taken to reduce the voltage to below 3.6 V, which is the maximum allowable voltage on the USBn\_VBUS pins in this case.

One method is to use a voltage divider to connect the USBn\_VBUS pins to VBUS on the USB connector. The voltage divider ratio should be such that the USB\_VBUS pin will be greater than 0.7VDDIO to indicate a logic HIGH while below the 3.6 V allowable maximum voltage.

For the following operating conditions

$$VBUS_{max} = 5.25 \text{ V}$$

$$VDDIO = 3.6 \text{ V,}$$

the voltage divider should provide a reduction of 3.6 V/5.25 V or ~0.686 V.

For bus-powered devices, a regulator powered by USB can provide 3.3 V to VDDIO whenever bus power is present and ensure that power to the USBn\_VBUS pins is always present when the 5 V VBUS signal is applied. See [Figure 46](#).

**Remark:** Applying 5 V to the USBn\_VBUS pins for a short time while the regulator ramps up might compromise the long-term reliability of the part but does not affect its function.

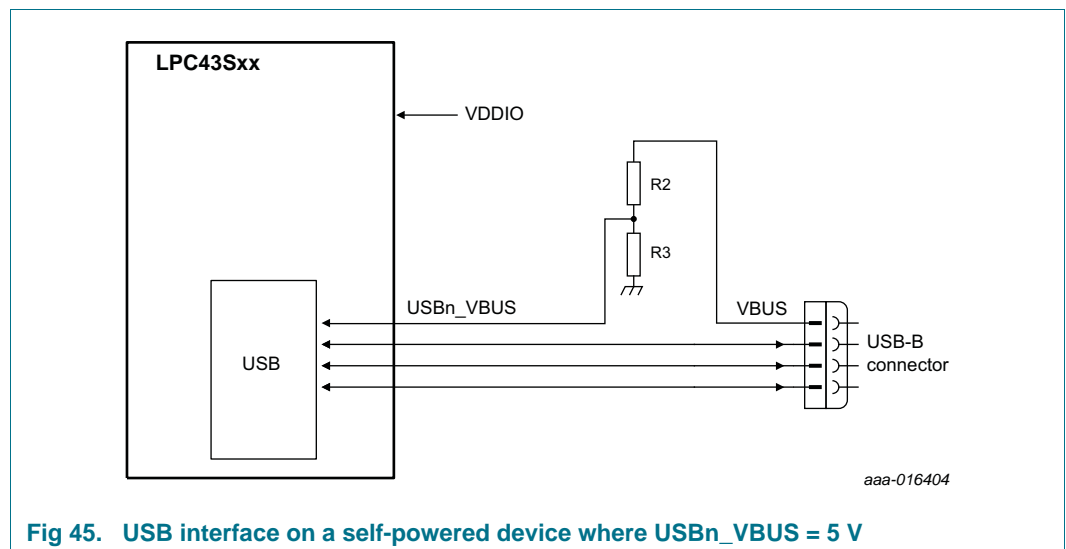

Fig 45. USB interface on a self-powered device where USBn\_VBUS = 5 V

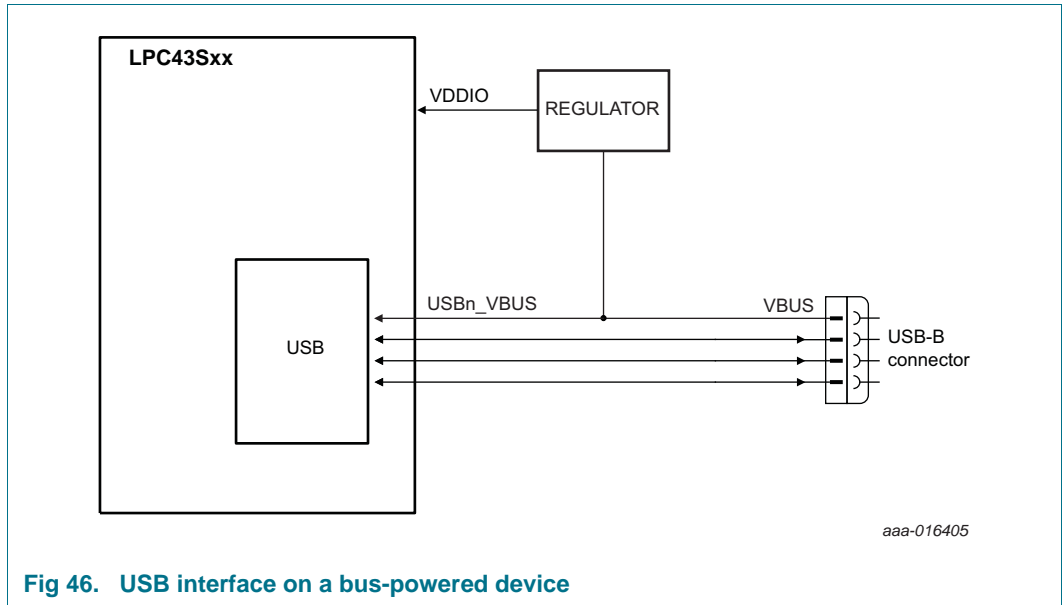

Fig 46. USB interface on a bus-powered device

**Remark:** If the VBUS function of the USB1 interface is not connected, configure the pin function for GPIO using the function control bits in the SYSCON block.

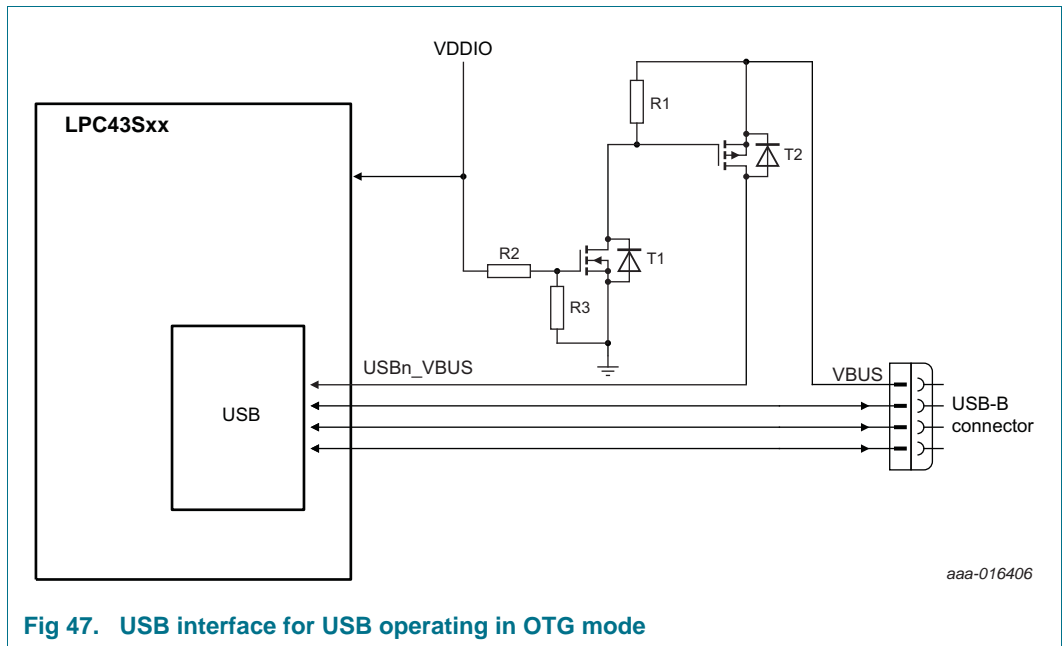

Fig 47. USB interface for USB operating in OTG mode

**Remark:** In OTG mode, it is important to be able to detect the VBUS level and to charge and discharge VBUS. This requires adding active devices that disconnect the link when VDDIO is not present.

### 13.8 Minimizing interference between digital signals and 12-bit ADC signals

To reduce interference from digital signals to the high-speed 12-bit ADC inputs, do not configure digital pins that are pinned out close to the ADC signals as outputs when using the 12-bit ADC. For the BGA256 package, the pins with interfering signals are shown in

Table 45.

Table 45. 12-bit ADC signal interferences for BGA256 package

12-bit ADC signal	LBGA256 ball	Interfering pins	LBGA256 ball
ADCHS_0	E3	P4_3, PC_0	C2, D4
ADCHS_1	C3	P4_1, P8_0, PC_0	A1, E5, D4
ADCHS_2	A4	PF_10, PF_11	A3, A2
ADCHS_3	A5	PF_9, PF_10	D6, A3
ADCHS_4	C6	P7_7, PB_6	B6, A6
ADCHS_5	B3	PF_11	A2
ADCHS_NEG	B5	P7_7, PF_8	B6, E6

### 13.9 12-bit ADCHS input selection

The high-speed, 12-bit ADCHS operates with an internally generated 1.2 V power supply. The input range for an ADC channel is 800 mV (peak-to-peak) in a band from 0 V to 1.2 V. The input range  $V_{in\_pos}$  is defined by  $V_{in\_pos} = V_{in\_neg} \pm 400$  mV where  $V_{in\_neg}$  can be either generated internally or supplied by the external pin ADCHS\_NEG.

The internally generated reference voltage is  $V_{in\_neg} = 500$  mV making the allowed input voltage  $V_{in\_pos}$  on any ADC channel  $100 \text{ mV} \leq V_{in\_pos} \leq 900 \text{ mV}$ . See [Figure 48](#).

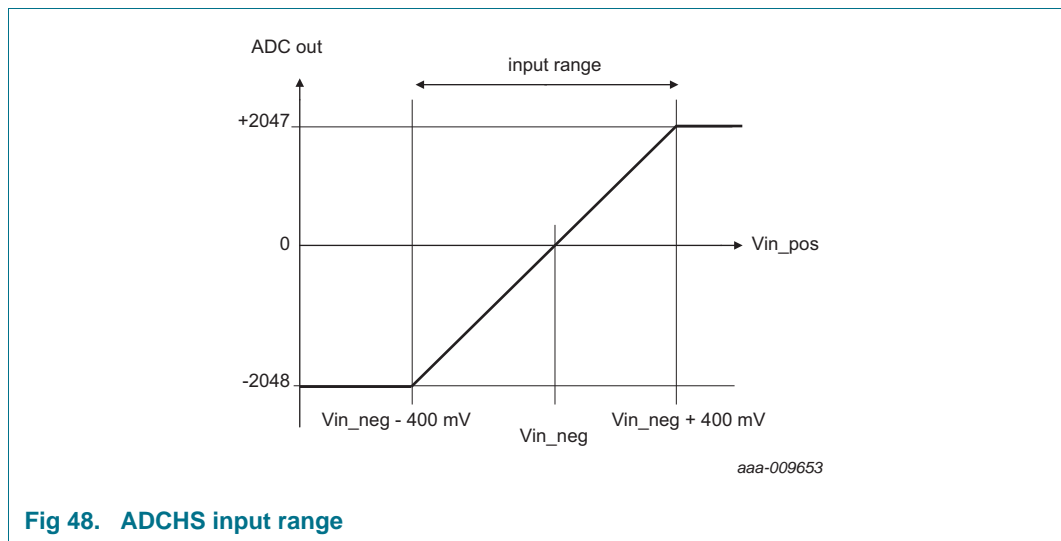
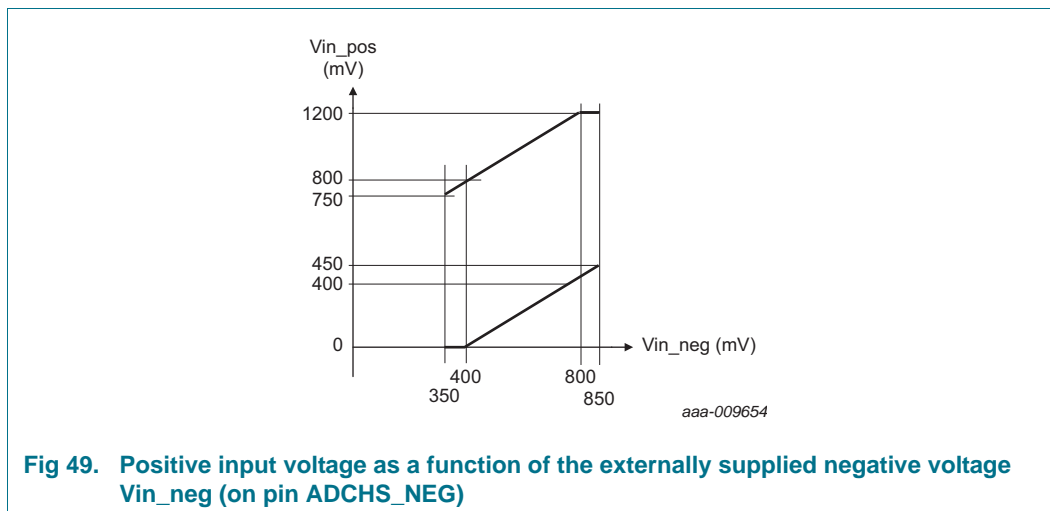

Fig 48. ADCHS input range

The allowed input range for  $V_{in\_neg}$ , if supplied externally on pin ADCHS\_NEG, is  $350\text{ mV} \leq V_{in\_neg} \leq 900\text{ mV}$ . See [Figure 49](#).



For the internally generated negative reference voltage  $V_{in\_neg} = 500\text{ mV}$ , one of the following circuits are recommended for the ADC channel input:

1. Inverting single-ended with gain = 1 or for input range 0 V to 3.3 V
2. Non-inverting single-ended with gain = 1
3. Non-inverting single-ended for input range 0 V to 3.3 V

13.9.1 Inverting single-ended circuit

For the inverting single-ended circuit only one op-amp is needed. A 1.24 V shunt voltage reference is used for creating an offset voltage of 450 mV. The disadvantage is that the signal output of the circuit is inverted. However, this can be easily solved in software by subtracting the ADC output from 4095, which is the maximum value of the 12-bit result.

(2)

$$V_{out} = V_{com} \frac{R4}{R3 + R4} \times \left( 1 + \frac{R2}{R1} \right) - Vin_{pos} \frac{R2}{R1}$$

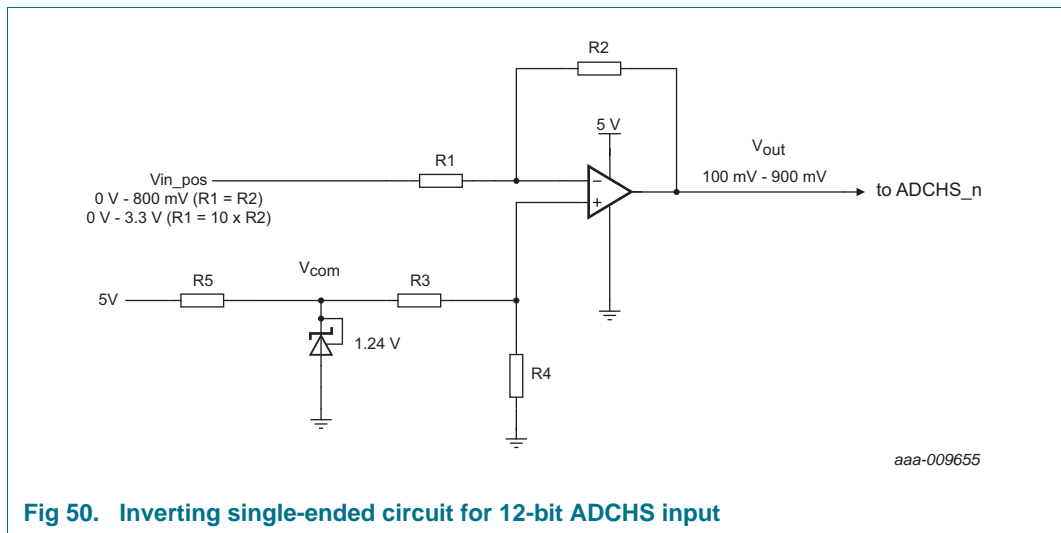

Fig 50. Inverting single-ended circuit for 12-bit ADCHS input

13.9.2 Non-inverting single-ended circuit with gain = 1

The advantage of having a non-inverting circuit comes at the cost of adding an additional op-amp for a high-impedance voltage reference to prevent the reference level being influenced by the input signal. This circuit is recommended for an input voltage from 100 mV to 800 mV using the internal negative reference voltage.

(3)

$$V_{out} = V_{in\_pos} + V_{com} \text{ (for } R3 = R4 \text{ and } R1 = R2\text{)}$$

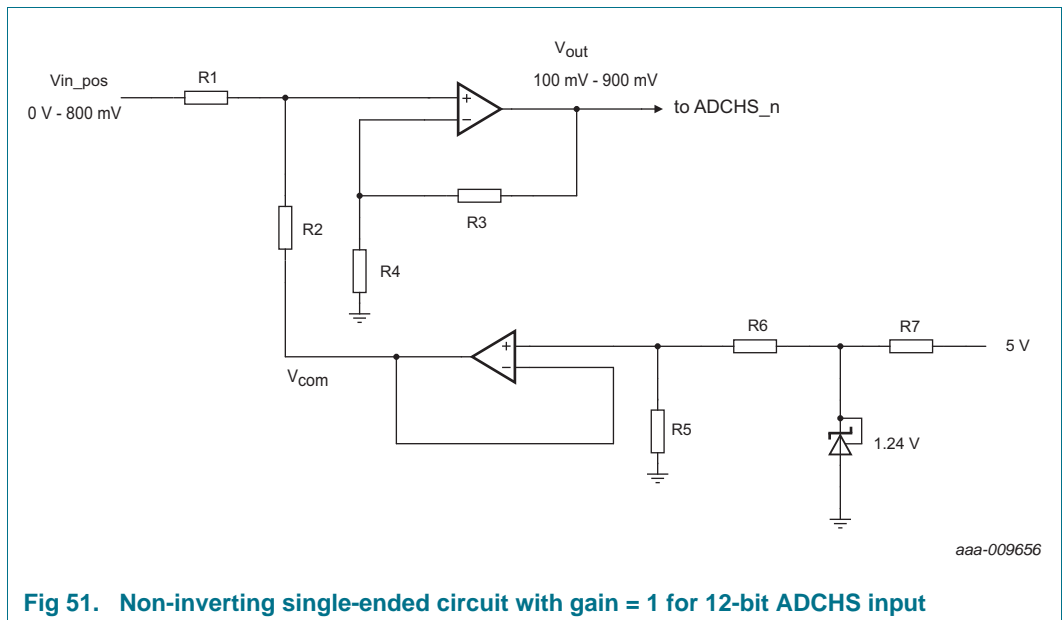

Fig 51. Non-inverting single-ended circuit with gain = 1 for 12-bit ADC input

**13.9.3 Non-inverting single-ended circuit for input 0 V to 3.3 V**

The advantage of having a non-inverting circuit comes at the cost of adding an additional op-amp for a high-impedance voltage reference to prevent the reference level being influenced by the input signal. This circuit is recommended for an input voltage from 0 V to 3.3 V using the internal negative reference voltage.

(4)

$$V_{out} = V_{com} \frac{R1}{R1 + R2}$$

(5)

$$V_{com} = (1.24 \text{ V}) \frac{R3}{R3 + R4}$$

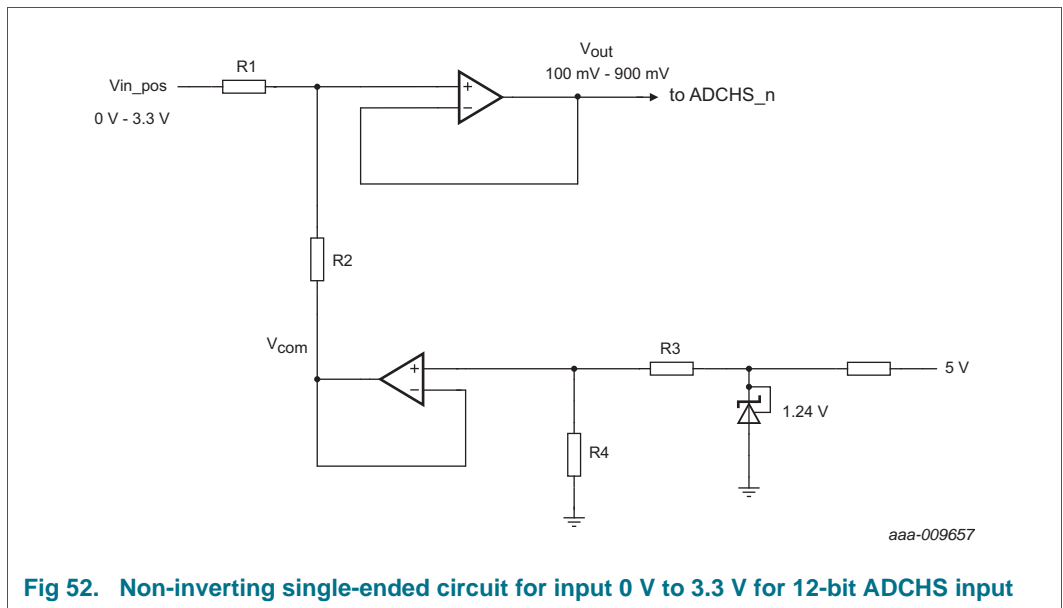

**Fig 52. Non-inverting single-ended circuit for input 0 V to 3.3 V for 12-bit ADCHS input**

14. Package outline

LPGA256: plastic low profile ball grid array package; 256 balls; body 17 x 17 x 1 mm

SOT740-2

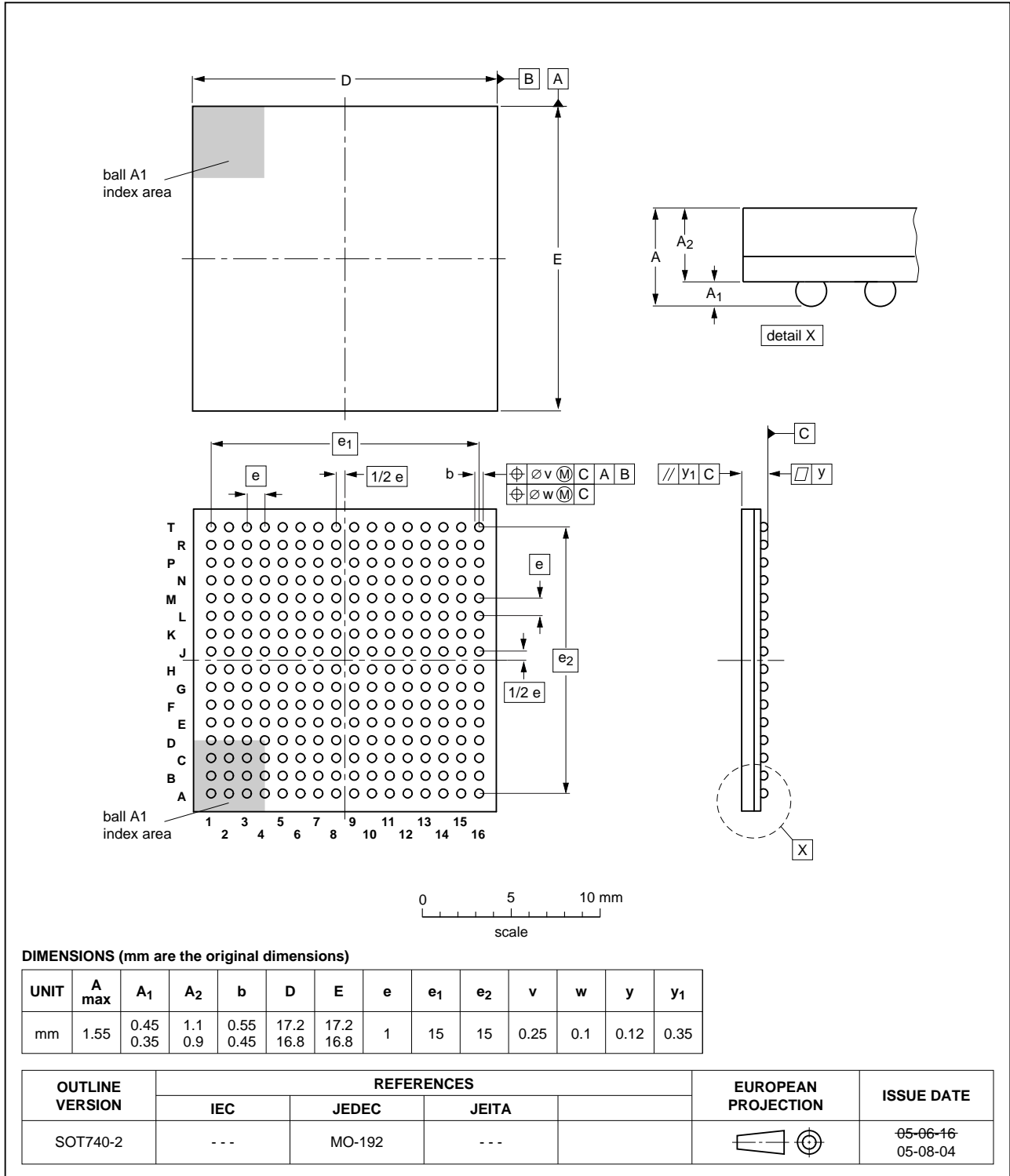

Fig 53. Package outline LPGA256 package

TFBGA100: plastic thin fine-pitch ball grid array package; 100 balls; body 9 x 9 x 0.7 mm

SOT926-1

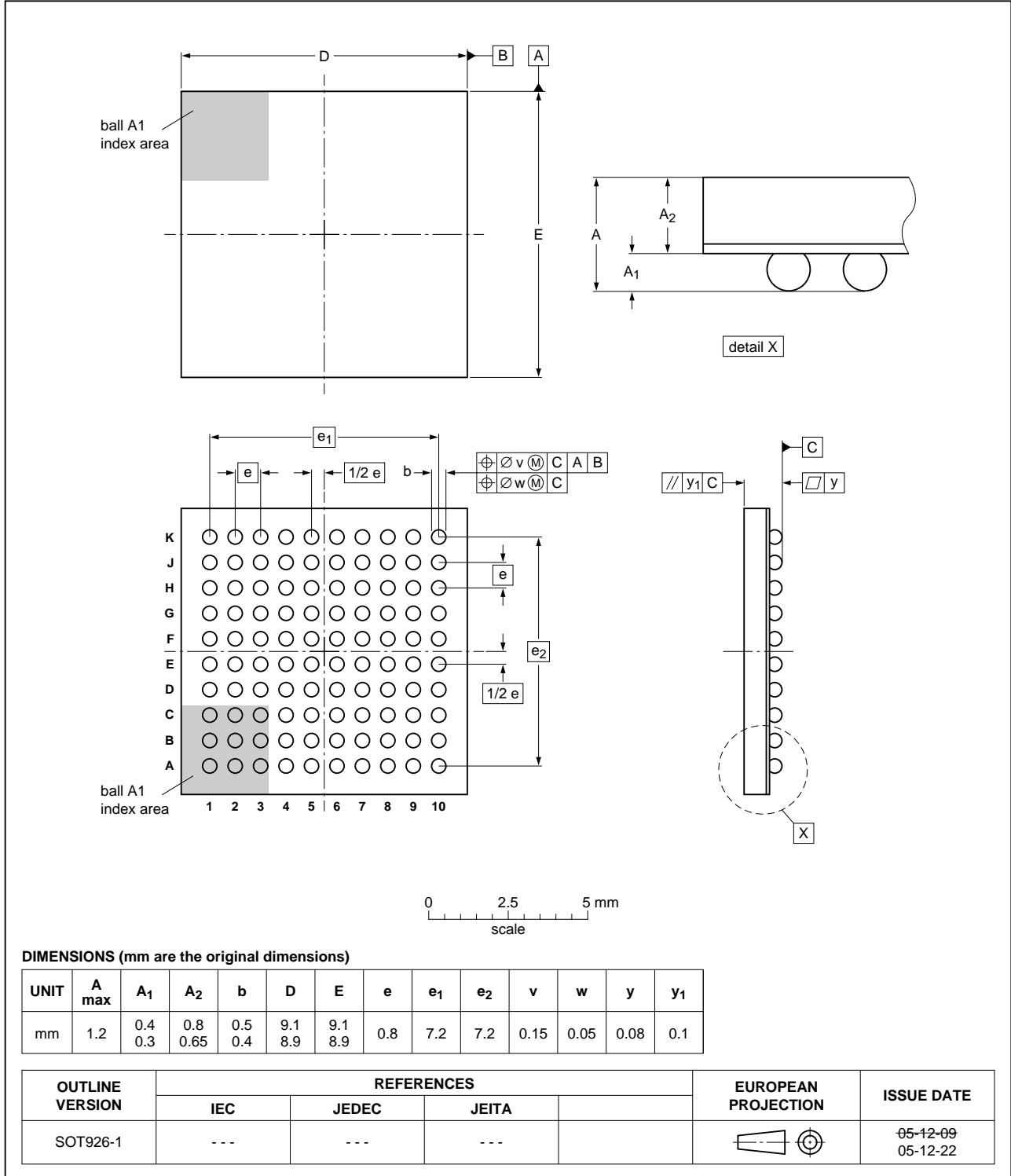

Fig 54. Package outline of the TFBGA100 package

15. Soldering

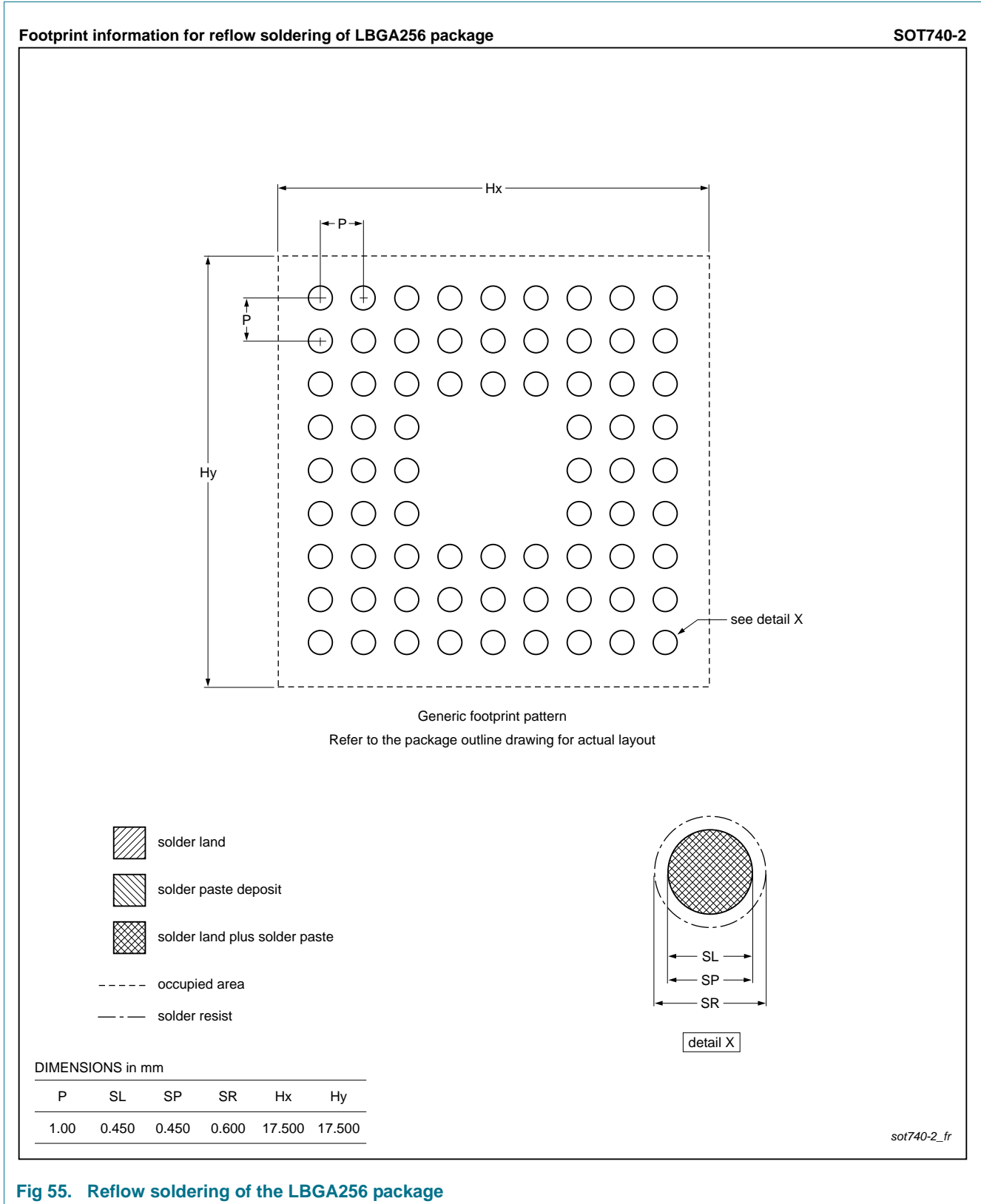
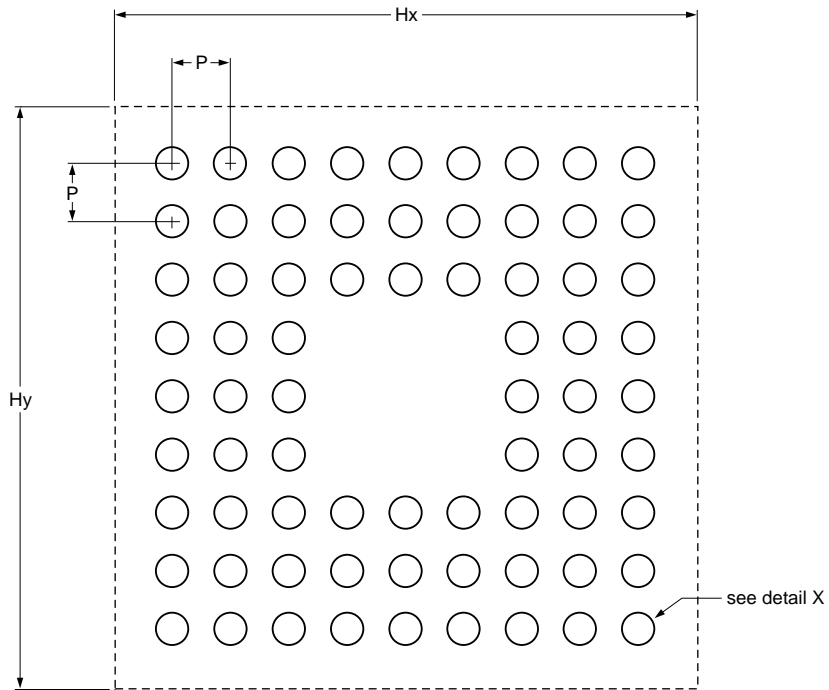

Fig 55. Reflow soldering of the LBG256 package

Footprint information for reflow soldering of TFBGA100 package

SOT926-1



Generic footprint pattern  
Refer to the package outline drawing for actual layout

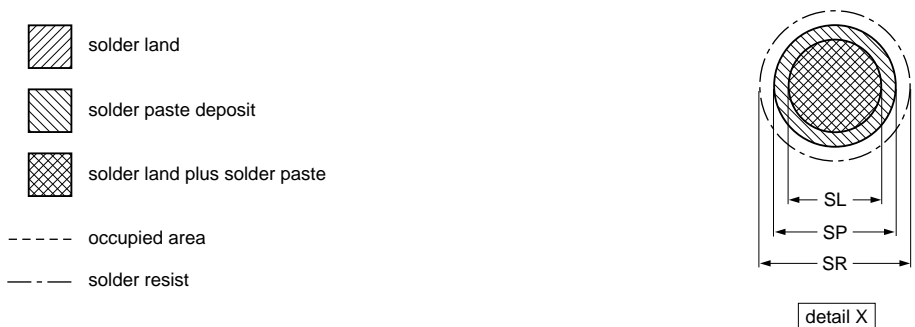

DIMENSIONS in mm

P	SL	SP	SR	Hx	Hy
0.80	0.330	0.400	0.480	9.400	9.400

sot926-1\_fr

Fig 56. Reflow soldering of the TFBGA100 package

## 16. Abbreviations

**Table 46. Abbreviations**

Acronym	Description
ADC	Analog-to-Digital Converter
AHB	Advanced High-performance Bus
APB	Advanced Peripheral Bus
API	Application Programming Interface
BOD	BrownOut Detection
CAN	Controller Area Network
CMAC	Cipher-based Message Authentication Code
CSMA/CD	Carrier Sense Multiple Access with Collision Detection
DAC	Digital-to-Analog Converter
DC-DC	Direct Current-to-Direct Current
DMA	Direct Memory Access
GPIO	General Purpose Input/Output
IRC	Internal RC
IrDA	Infrared Data Association
JTAG	Joint Test Action Group
LCD	Liquid Crystal Display
LSB	Least Significant Bit
MAC	Media Access Control
MCU	MicroController Unit
MIIM	Media Independent Interface Management
n.c.	not connected
OHCI	Open Host Controller Interface
OTG	On-The-Go
PHY	Physical Layer
PLL	Phase-Locked Loop
PMC	Power Mode Control
PWM	Pulse Width Modulator
RIT	Repetitive Interrupt Timer
RMII	Reduced Media Independent Interface
SDRAM	Synchronous Dynamic Random Access Memory
SIMD	Single Instruction Multiple Data
SPI	Serial Peripheral Interface
SSI	Serial Synchronous Interface
SSP	Synchronous Serial Port
UART	Universal Asynchronous Receiver/Transmitter
ULPI	UTMI+ Low Pin Interface
USART	Universal Synchronous Asynchronous Receiver/Transmitter
USB	Universal Serial Bus
UTMI	USB2.0 Transceiver Macrocell Interface

## 17. References

---

- [1] LPC43S70 Errata sheet.

## 18. Revision history

Table 47. Revision history

Document ID	Release date	Data sheet status	Change notice	Supersedes
LPC43S70 v.1.2	20160315	Product data sheet	-	LPC43S70 v.1.1
Modifications:	<ul style="list-style-type: none"> <li>Updated <a href="#">Table 30 “Dynamic characteristics: Dynamic external memory interface”</a>: Read cycle parameters <math>t_{h(D)}</math> min value is 2.2 ns and max value is “-”.</li> </ul>			
LPC43S70 v.1.1	20151117	Product data sheet	2015110031	LPC43S70 v.1.0
Modifications:	<ul style="list-style-type: none"> <li>Added GPCLKIN section and table. See Section 11.5 “GPCLKIN” and Table 19 “Dynamic characteristic: GPCLKIN”.</li> <li>Updated SSP slave and SSP master values in Table 25 “Dynamic characteristics: SSP pins in SPI mode”. Updated footnote 2 to: <math>T_{cy(clk)} \geq 12 \times T_{cy(PCLK)}</math>. <ul style="list-style-type: none"> <li>removed <math>t_{v(Q)}</math>, data output valid time in SPI mode, minimum value of <math>3 \cdot (1/PCLK)</math> from SSP slave mode.</li> <li>added units to <math>t_d</math>, delay time, for SSP slave and master mode.</li> </ul> </li> </ul>			
LPC43S70 v.1.0	20150210	Product data sheet	-	-

## 19. Legal information

### 19.1 Data sheet status

Document status <sup>[1][2]</sup>	Product status <sup>[3]</sup>	Definition
Objective [short] data sheet	Development	This document contains data from the objective specification for product development.
Preliminary [short] data sheet	Qualification	This document contains data from the preliminary specification.
Product [short] data sheet	Production	This document contains the product specification.

[1] Please consult the most recently issued document before initiating or completing a design.

[2] The term 'short data sheet' is explained in section "Definitions".

[3] The product status of device(s) described in this document may have changed since this document was published and may differ in case of multiple devices. The latest product status information is available on the Internet at URL <http://www.nxp.com>.

### 19.2 Definitions

**Draft** — The document is a draft version only. The content is still under internal review and subject to formal approval, which may result in modifications or additions. NXP Semiconductors does not give any representations or warranties as to the accuracy or completeness of information included herein and shall have no liability for the consequences of use of such information.

**Short data sheet** — A short data sheet is an extract from a full data sheet with the same product type number(s) and title. A short data sheet is intended for quick reference only and should not be relied upon to contain detailed and full information. For detailed and full information see the relevant full data sheet, which is available on request via the local NXP Semiconductors sales office. In case of any inconsistency or conflict with the short data sheet, the full data sheet shall prevail.

**Product specification** — The information and data provided in a Product data sheet shall define the specification of the product as agreed between NXP Semiconductors and its customer, unless NXP Semiconductors and customer have explicitly agreed otherwise in writing. In no event however, shall an agreement be valid in which the NXP Semiconductors product is deemed to offer functions and qualities beyond those described in the Product data sheet.

### 19.3 Disclaimers

**Limited warranty and liability** — Information in this document is believed to be accurate and reliable. However, NXP Semiconductors does not give any representations or warranties, expressed or implied, as to the accuracy or completeness of such information and shall have no liability for the consequences of use of such information. NXP Semiconductors takes no responsibility for the content in this document if provided by an information source outside of NXP Semiconductors.

In no event shall NXP Semiconductors be liable for any indirect, incidental, punitive, special or consequential damages (including - without limitation - lost profits, lost savings, business interruption, costs related to the removal or replacement of any products or rework charges) whether or not such damages are based on tort (including negligence), warranty, breach of contract or any other legal theory.

Notwithstanding any damages that customer might incur for any reason whatsoever, NXP Semiconductors' aggregate and cumulative liability towards customer for the products described herein shall be limited in accordance with the *Terms and conditions of commercial sale* of NXP Semiconductors.

**Right to make changes** — NXP Semiconductors reserves the right to make changes to information published in this document, including without limitation specifications and product descriptions, at any time and without notice. This document supersedes and replaces all information supplied prior to the publication hereof.

**Suitability for use** — NXP Semiconductors products are not designed, authorized or warranted to be suitable for use in life support, life-critical or safety-critical systems or equipment, nor in applications where failure or malfunction of an NXP Semiconductors product can reasonably be expected to result in personal injury, death or severe property or environmental damage. NXP Semiconductors and its suppliers accept no liability for inclusion and/or use of NXP Semiconductors products in such equipment or applications and therefore such inclusion and/or use is at the customer's own risk.

**Applications** — Applications that are described herein for any of these products are for illustrative purposes only. NXP Semiconductors makes no representation or warranty that such applications will be suitable for the specified use without further testing or modification.

Customers are responsible for the design and operation of their applications and products using NXP Semiconductors products, and NXP Semiconductors accepts no liability for any assistance with applications or customer product design. It is customer's sole responsibility to determine whether the NXP Semiconductors product is suitable and fit for the customer's applications and products planned, as well as for the planned application and use of customer's third party customer(s). Customers should provide appropriate design and operating safeguards to minimize the risks associated with their applications and products.

NXP Semiconductors does not accept any liability related to any default, damage, costs or problem which is based on any weakness or default in the customer's applications or products, or the application or use by customer's third party customer(s). Customer is responsible for doing all necessary testing for the customer's applications and products using NXP Semiconductors products in order to avoid a default of the applications and the products or of the application or use by customer's third party customer(s). NXP does not accept any liability in this respect.

**Limiting values** — Stress above one or more limiting values (as defined in the Absolute Maximum Ratings System of IEC 60134) will cause permanent damage to the device. Limiting values are stress ratings only and (proper) operation of the device at these or any other conditions above those given in the Recommended operating conditions section (if present) or the Characteristics sections of this document is not warranted. Constant or repeated exposure to limiting values will permanently and irreversibly affect the quality and reliability of the device.

**Terms and conditions of commercial sale** — NXP Semiconductors products are sold subject to the general terms and conditions of commercial sale, as published at <http://www.nxp.com/profile/terms>, unless otherwise agreed in a valid written individual agreement. In case an individual agreement is concluded only the terms and conditions of the respective agreement shall apply. NXP Semiconductors hereby expressly objects to applying the customer's general terms and conditions with regard to the purchase of NXP Semiconductors products by customer.

**No offer to sell or license** — Nothing in this document may be interpreted or construed as an offer to sell products that is open for acceptance or the grant, conveyance or implication of any license under any copyrights, patents or other industrial or intellectual property rights.

**Export control** — This document as well as the item(s) described herein may be subject to export control regulations. Export might require a prior authorization from competent authorities.

**Non-automotive qualified products** — Unless this data sheet expressly states that this specific NXP Semiconductors product is automotive qualified, the product is not suitable for automotive use. It is neither qualified nor tested in accordance with automotive testing or application requirements. NXP Semiconductors accepts no liability for inclusion and/or use of non-automotive qualified products in automotive equipment or applications.

In the event that customer uses the product for design-in and use in automotive applications to automotive specifications and standards, customer (a) shall use the product without NXP Semiconductors' warranty of the product for such automotive applications, use and specifications, and (b)

whenever customer uses the product for automotive applications beyond NXP Semiconductors' specifications such use shall be solely at customer's own risk, and (c) customer fully indemnifies NXP Semiconductors for any liability, damages or failed product claims resulting from customer design and use of the product for automotive applications beyond NXP Semiconductors' standard warranty and NXP Semiconductors' product specifications.

## 19.4 Trademarks

Notice: All referenced brands, product names, service names and trademarks are the property of their respective owners.

**I<sup>2</sup>C-bus** — logo is a trademark of NXP B.V.

## 20. Contact information

For more information, please visit: <http://www.nxp.com>

For sales office addresses, please send an email to: [salesaddresses@nxp.com](mailto:salesaddresses@nxp.com)

## 21. Contents

<b>1</b>	<b>General description</b> . . . . .	<b>1</b>	7.17.6	High-speed USB Host/Device/OTG interface (USB0) . . . . .	70
<b>2</b>	<b>Features and benefits</b> . . . . .	<b>1</b>	7.17.6.1	Features . . . . .	71
<b>3</b>	<b>Applications</b> . . . . .	<b>4</b>	7.17.7	High-speed USB Host/Device interface with ULPI (USB1) . . . . .	71
<b>4</b>	<b>Ordering information</b> . . . . .	<b>5</b>	7.17.7.1	Features . . . . .	71
4.1	Ordering options . . . . .	5	7.17.8	LCD controller . . . . .	71
<b>5</b>	<b>Block diagram</b> . . . . .	<b>6</b>	7.17.8.1	Features . . . . .	72
<b>6</b>	<b>Pinning information</b> . . . . .	<b>7</b>	7.17.9	Ethernet . . . . .	72
6.1	Pinning . . . . .	7	7.17.9.1	Features . . . . .	72
6.2	Pin description . . . . .	7	7.18	Digital serial peripherals . . . . .	73
<b>7</b>	<b>Functional description</b> . . . . .	<b>57</b>	7.18.1	UART1 . . . . .	73
7.1	Architectural overview . . . . .	57	7.18.1.1	Features . . . . .	73
7.2	ARM Cortex-M4 processor . . . . .	57	7.18.2	USART0/2/3 . . . . .	73
7.3	ARM Cortex-M0 processors . . . . .	57	7.18.2.1	Features . . . . .	73
7.3.1	ARM Cortex-M0 coprocessor . . . . .	57	7.18.3	SPI serial I/O controller . . . . .	74
7.3.2	ARM Cortex-M0 subsystem . . . . .	57	7.18.3.1	Features . . . . .	74
7.4	Interprocessor communication . . . . .	58	7.18.4	SSP serial I/O controller . . . . .	74
7.5	AHB multilayer matrix . . . . .	59	7.18.4.1	Features . . . . .	74
7.6	Nested Vectored Interrupt Controller (NVIC) . . . . .	59	7.18.5	I <sup>2</sup> C-bus interface . . . . .	74
7.6.1	Features . . . . .	60	7.18.5.1	Features . . . . .	75
7.6.2	Interrupt sources . . . . .	60	7.18.6	I <sup>2</sup> S interface . . . . .	75
7.7	System Tick timer (SysTick) . . . . .	60	7.18.6.1	Features . . . . .	75
7.8	Event router . . . . .	60	7.18.7	C_CAN . . . . .	76
7.9	Global Input Multiplexer Array (GIMA) . . . . .	61	7.18.7.1	Features . . . . .	76
7.9.1	Features . . . . .	61	7.19	Counter/timers and motor control . . . . .	76
7.10	On-chip static RAM . . . . .	61	7.19.1	General purpose 32-bit timers/external event counters . . . . .	76
7.11	In-System Programming (ISP) . . . . .	61	7.19.1.1	Features . . . . .	76
7.12	Boot ROM . . . . .	61	7.19.2	Motor control PWM . . . . .	77
7.13	Memory mapping . . . . .	63	7.19.3	Quadrature Encoder Interface (QEI) . . . . .	77
7.14	One-Time Programmable (OTP) memory . . . . .	66	7.19.3.1	Features . . . . .	77
7.15	General Purpose I/O (GPIO) . . . . .	66	7.19.4	Repetitive Interrupt (RI) timer . . . . .	78
7.15.1	Features . . . . .	66	7.19.4.1	Features . . . . .	78
7.16	Configurable digital peripherals . . . . .	66	7.19.5	Windowed WatchDog Timer (WWDT) . . . . .	78
7.16.1	State Configurable Timer (SCT) subsystem . . . . .	66	7.19.5.1	Features . . . . .	78
7.16.1.1	Features . . . . .	67	7.20	Analog peripherals . . . . .	78
7.16.2	Serial GPIO (SGPIO) . . . . .	67	7.20.1	12-bit high-speed Analog-to-Digital Converter (ADCHS) . . . . .	78
7.16.2.1	Features . . . . .	67	7.20.1.1	Features . . . . .	78
7.17	AHB peripherals . . . . .	67	7.20.2	10-bit Analog-to-Digital Converter (ADC0/1) . . . . .	79
7.17.1	AES decryption/encryption . . . . .	67	7.20.2.1	Features . . . . .	79
7.17.1.1	Features . . . . .	68	7.20.3	Digital-to-Analog Converter (DAC) . . . . .	79
7.17.2	General Purpose DMA (GPDMA) . . . . .	68	7.20.3.1	Features . . . . .	79
7.17.2.1	Features . . . . .	68	7.21	Peripherals in the RTC power domain . . . . .	79
7.17.3	SPI Flash Interface (SPIFI) . . . . .	69	7.21.1	RTC . . . . .	79
7.17.3.1	Features . . . . .	69	7.21.1.1	Features . . . . .	79
7.17.4	SD/MMC card interface . . . . .	70			
7.17.5	External Memory Controller (EMC) . . . . .	70			
7.17.5.1	Features . . . . .	70			

continued >>

7.21.2	Alarm timer . . . . .	80	13.5	Standard I/O pin configuration . . . . .	138
7.22	System control . . . . .	80	13.6	Reset pin configuration . . . . .	139
7.22.1	Configuration registers (CREG) . . . . .	80	13.7	Suggested USB interface solutions . . . . .	139
7.22.2	System Control Unit (SCU) . . . . .	80	13.8	Minimizing interference between digital signals and 12-bit ADC signals . . . . .	142
7.22.3	Clock Generation Unit (CGU) . . . . .	80	13.9	12-bit ADCHS input selection . . . . .	142
7.22.4	Internal RC oscillator (IRC) . . . . .	81	13.9.1	Inverting single-ended circuit . . . . .	144
7.22.5	PLL0USB (for USB0) . . . . .	81	13.9.2	Non-inverting single-ended circuit with gain = 1 . . . . .	145
7.22.6	PLL0AUDIO (for audio) . . . . .	81	13.9.3	Non-inverting single-ended circuit for input 0 V to 3.3 V . . . . .	146
7.22.7	System PLL1 . . . . .	81	<b>14</b>	<b>Package outline . . . . .</b>	<b>147</b>
7.22.8	Reset Generation Unit (RGU) . . . . .	81	<b>15</b>	<b>Soldering . . . . .</b>	<b>149</b>
7.22.9	Power control . . . . .	81	<b>16</b>	<b>Abbreviations . . . . .</b>	<b>151</b>
7.22.9.1	Memory retention in Power-down modes . . . . .	82	<b>17</b>	<b>References . . . . .</b>	<b>152</b>
7.22.9.2	Power Management Controller (PMC) . . . . .	83	<b>18</b>	<b>Revision history . . . . .</b>	<b>153</b>
7.23	Serial Wire Debug/JTAG . . . . .	84	<b>19</b>	<b>Legal information . . . . .</b>	<b>154</b>
<b>8</b>	<b>Limiting values . . . . .</b>	<b>85</b>	19.1	Data sheet status . . . . .	154
<b>9</b>	<b>Thermal characteristics . . . . .</b>	<b>86</b>	19.2	Definitions . . . . .	154
<b>10</b>	<b>Static characteristics . . . . .</b>	<b>87</b>	19.3	Disclaimers . . . . .	154
10.1	Power consumption . . . . .	94	19.4	Trademarks . . . . .	155
10.2	Peripheral power consumption . . . . .	98	<b>20</b>	<b>Contact information . . . . .</b>	<b>155</b>
10.3	BOD and band gap static characteristics . . . . .	100	<b>21</b>	<b>Contents . . . . .</b>	<b>156</b>
10.4	Electrical pin characteristics . . . . .	102			
<b>11</b>	<b>Dynamic characteristics . . . . .</b>	<b>106</b>			
11.1	Wake-up times . . . . .	106			
11.2	External clock for oscillator in slave mode . . . . .	106			
11.3	Crystal oscillator . . . . .	107			
11.4	IRC oscillator . . . . .	107			
11.5	GPCLKIN . . . . .	107			
11.6	I/O pins . . . . .	107			
11.7	RTC oscillator . . . . .	109			
11.8	I <sup>2</sup> C-bus . . . . .	109			
11.9	I <sup>2</sup> S-bus interface . . . . .	110			
11.10	USART interface . . . . .	111			
11.11	SSP interface . . . . .	113			
11.12	SPI interface . . . . .	116			
11.13	SSP/SPI timing diagrams . . . . .	117			
11.14	SPIFI . . . . .	119			
11.15	SGPIO timing . . . . .	119			
11.16	External memory interface . . . . .	121			
11.17	USB interface . . . . .	126			
11.18	Ethernet . . . . .	127			
11.19	SD/MMC . . . . .	129			
11.20	LCD . . . . .	129			
<b>12</b>	<b>ADC/DAC electrical characteristics . . . . .</b>	<b>130</b>			
<b>13</b>	<b>Application information . . . . .</b>	<b>134</b>			
13.1	LCD panel signal usage . . . . .	134			
13.2	Crystal oscillator . . . . .	136			
13.3	RTC oscillator . . . . .	138			
13.4	XTAL and RTCX Printed Circuit Board (PCB) layout guidelines . . . . .	138			

Please be aware that important notices concerning this document and the product(s) described herein, have been included in section 'Legal information'.

© NXP B.V. 2016. All rights reserved.

For more information, please visit: <http://www.nxp.com>  
 For sales office addresses, please send an email to: [salesaddresses@nxp.com](mailto:salesaddresses@nxp.com)  
 Date of release: 15 March 2016  
 Document identifier: LPC43S70