



# TEA1703TS

GreenChip SMPS standby control IC

Rev. 1 — 7 June 2012

Product data sheet

## 1. General description

The TEA1703TS is a low power standby controller IC intended to be used in applications which require an extreme low no-load standby power.

The TEA1703TS includes circuitry for detecting output voltage, output power and switching of the SMPS. The TEA1703TS integrates a switched-mode optocoupler driver, which enables an optocoupler to be driven with a high peak current while keeping the required power low<sup>1</sup>.

The typical current consumption of a TEA1703TS is 30  $\mu$ A. In a typical notebook adapter application, the power consumption of a TEA1703TS is < 0.5 mW.

## 2. Features and benefits

- Switched-Mode Power Supply (SMPS) standby controller IC enabling very low power standby operation
- Large input voltage range (5 V up to 30 V)
- Very low supply current (30  $\mu$ A) typical
- Switched-mode optocoupler driver output (NXP Semiconductors patented)
- Easy application, only 6 pins to connect

## 3. Applications

The device can be used in applications that require a very low power no-load standby.

## 4. Ordering information

Table 1. Ordering information

Type number	Package		Version
	Name	Description	
TEA1703TS	TSOP6	plastic surface mounted package; 6 leads	SOT457

1. NXP Semiconductors patented.



## 5. Block diagram

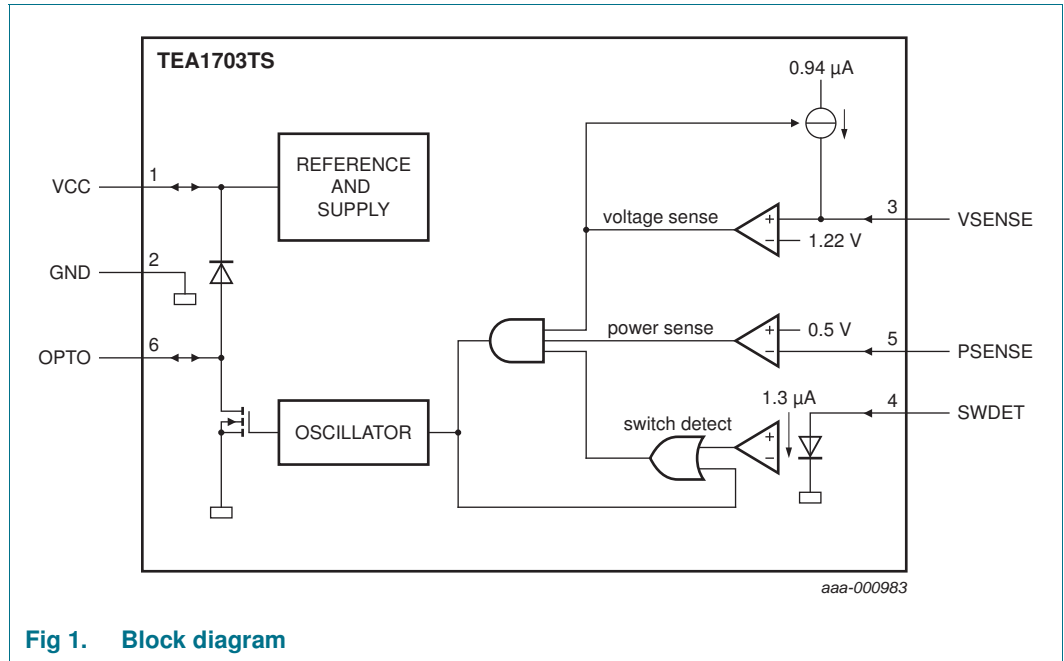

Fig 1. Block diagram

## 6. Pinning information

### 6.1 Pinning

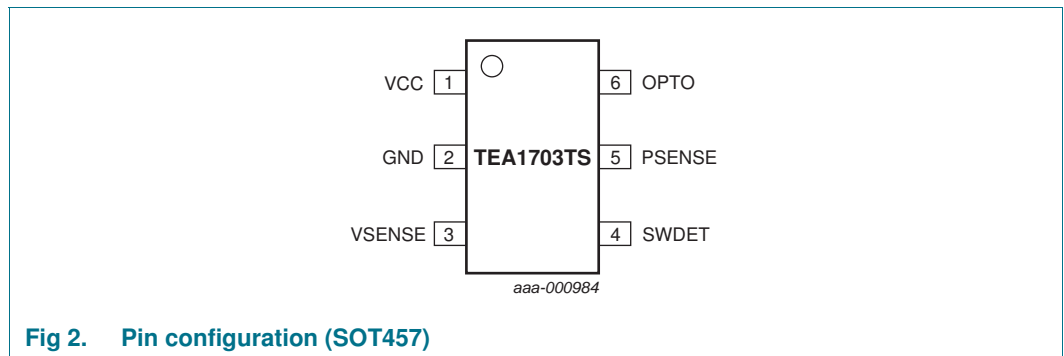

Fig 2. Pin configuration (SOT457)

### 6.2 Pin description

Table 2. Pin description

Symbol	Pin	Description
VCC	1	supply voltage
GND	2	ground
VSENSE	3	voltage sense input
SWDET	4	switch detect input
PSENSE	5	power sense input
OPTO	6	optocoupler driver

## 7. Functional description

### 7.1 General control

The TEA1703TS contains a standby controller for switched-mode power supplies. Typical configurations are shown in [Figure 3](#) and [Figure 4](#).

Typically the TEA1703TS senses the output voltage and output power of a switched-mode power supply. The output voltage is sensed using a resistive divider network connected to the VSENSE pin. The output power is sensed by determining the switching frequency of the converter using an external filtering network. The converter output power is dependent on the switching frequency, such as in a discontinuous conduction mode flyback converter which has a fixed primary peak current during low load operation.

The TEA1703TS can be used in combination with a TEA1753 flyback controller. The TEA1753T VINSENSE pin can be used to enter Standby mode. However, the VINSENSE pin is also used to reset a latched protection in the TEA1753T. The TEA1703TS has an integrated switching detection circuit which prevents unintentional resetting of a latched protection.

When the TEA1753T is not switching, the TEA1703TS does not activate Standby mode. Switching is detected using the SWDET pin as shown in [Figure 3](#).

When configured with the TEA1733, switching detection is only required if the primary-side  $V_{CC}$  (TEA1733 VCC pin) is discharged below the latched protection reset level. In [Figure 4](#) a Zener diode Z1 is connected in series with the NPN transistor Q1 which discharges  $V_{CC}$  on the VCC pin. The Zener diode is chosen to keep  $V_{CC}$  on the VCC pin just below the TEA1733  $V_{CC}$  start-up level while the application is in Standby mode, guaranteeing a short restart time. If the Zener diode is omitted, connect the switching detection input as shown in [Figure 4](#). Otherwise connect the SWDET pin using a series resistor to a fixed voltage.

The TEA1703TS has an open-drain optocoupler driver output with an integrated freewheeling diode to the VCC pin. The optocoupler is efficiently driven in pulse mode which ensures that the optocoupler Current Transfer Ratio (CTR) remains high; see [Section 7.7](#) and [Section 7.8](#).

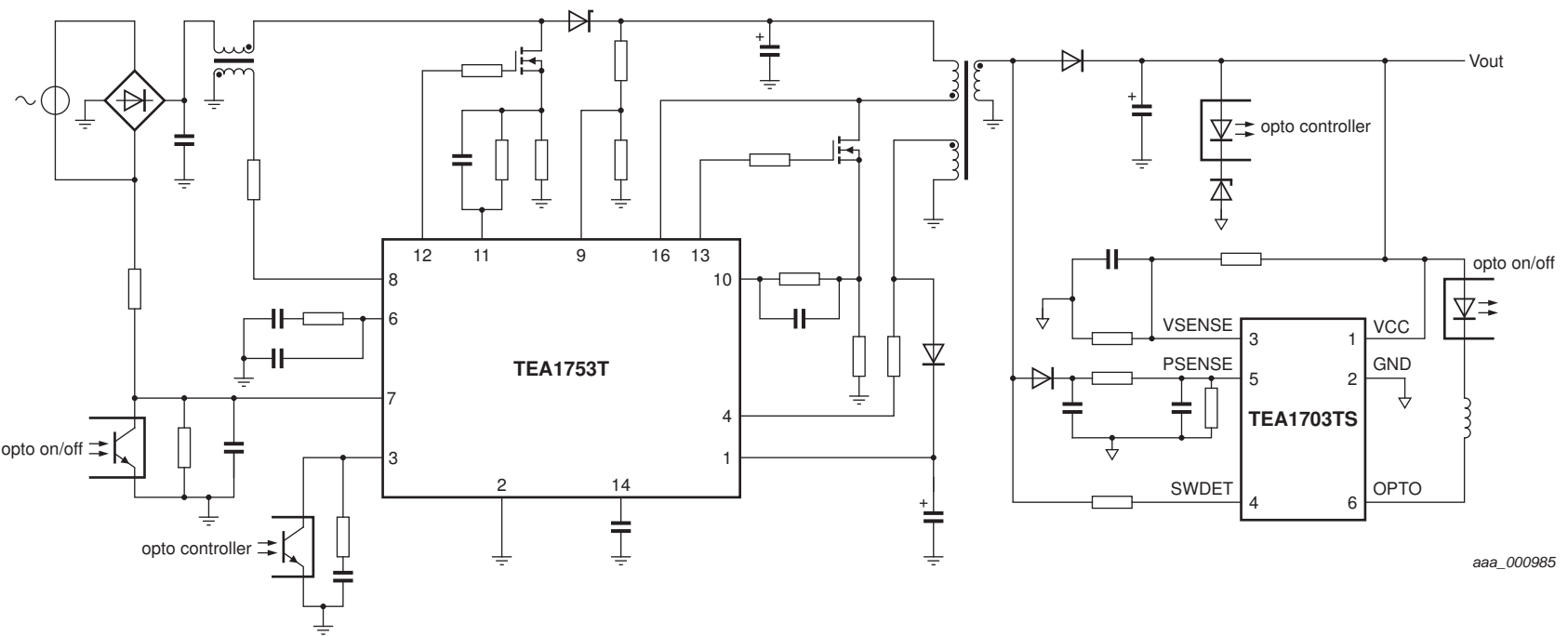

aaa\_000985

**Fig 3.** Typical configuration of TEA1703TS with TEA1753

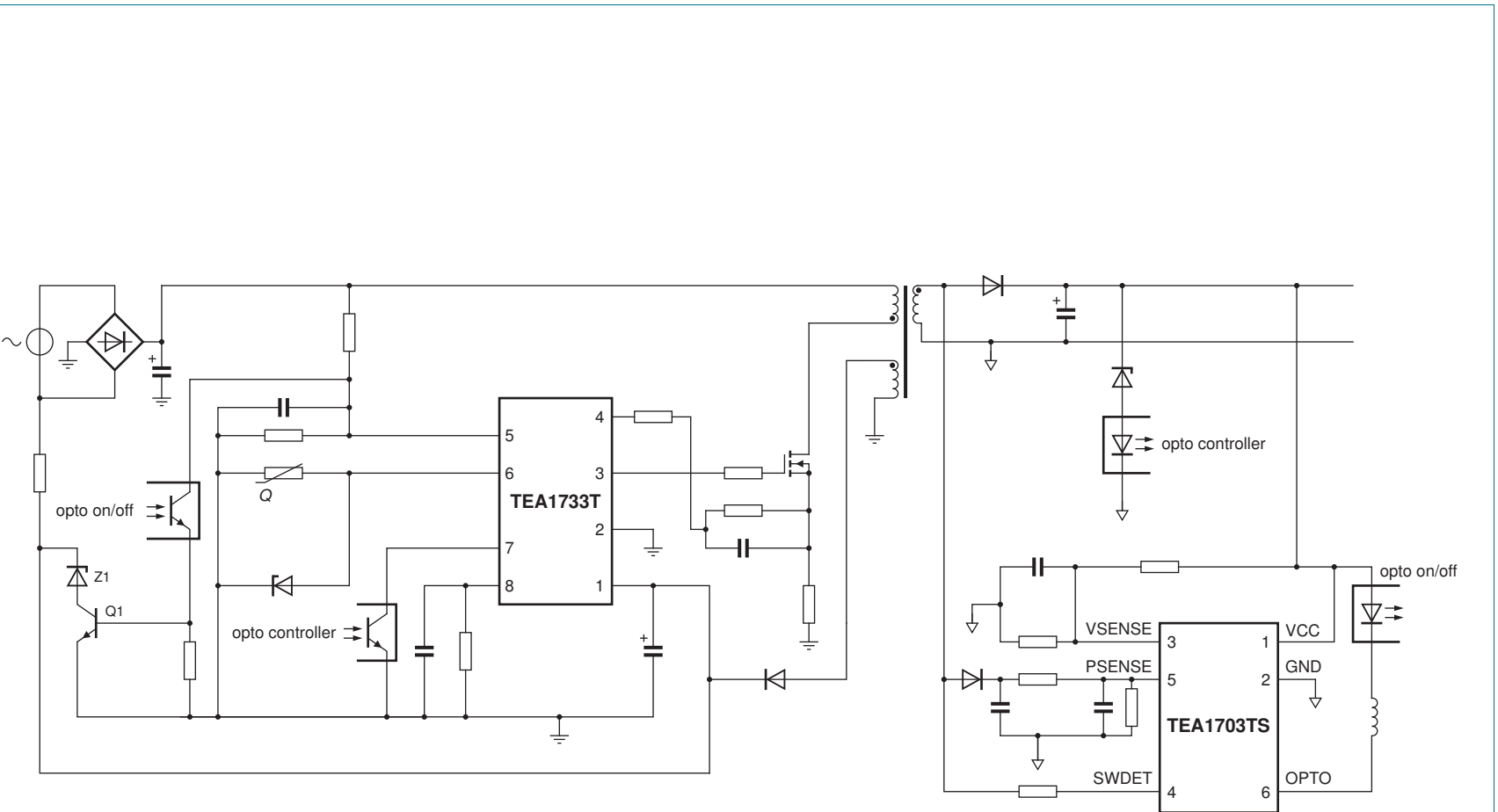

aaa-000986

**Fig 4.** Typical configuration of TEA1703TS with TEA1733

### 7.2 Standby mode operation

When the output load of the switched-mode power supply falls, the voltage on the PSENSE pin also falls. When the voltage on the PSENSE pin is  $< V_{th(PSENSE)}$ , the TEA1703TS activates the OPTO pin output when the SWDET pin current is  $> I_{th(det)sw}$ .

When the OPTO pin output is activated in a typical application, the TEA1703TS disables the switched-mode power supply. The output voltage starts to fall. After a period dependent on the connected output power and the output capacitor value, the VSENSE voltage falls below the  $V_{th(VSENSE)}$  level. The OPTO pin output is then disabled again. This function restarts the primary-side converter.

If the output power remains low, the application reverts to Standby mode again after the output capacitor has been recharged. When a normal load is detected, the converter resumes normal operation; see [Figure 5](#).

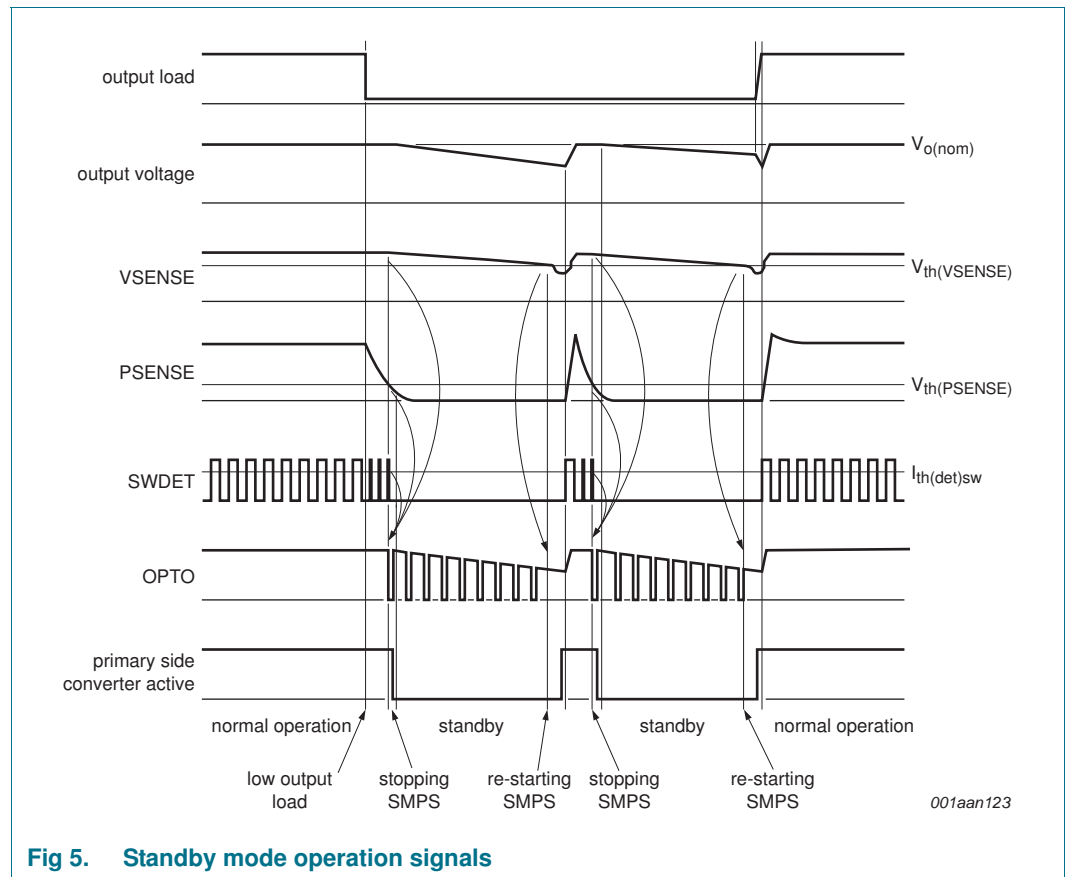

Fig 5. Standby mode operation signals

### 7.3 Voltage sensing (pin VSENSE)

If the voltage on the VSENSE pin is  $> V_{th(VSENSE)}$ , the VSENSE pin outputs a current  $I_{O(VSENSE)}$ . This current in combination with the external resistive divider, creates a hysteresis on the adapter output voltage level. In a typical application, the effective output voltage hysteresis is larger than that set by  $I_{O(VSENSE)}$  and the resistive divider. This is because the external PSENSE filter circuit keeps the PSENSE voltage  $> V_{th(PSENSE)}$  when the output capacitor is not charged up to the normal output voltage level.

#### 7.4 Power sensing (pin PSENSE)

Output power sensing is implemented using an external filter network on the PSENSE pin. The PSENSE input is not latched internally. If, during Standby mode, the PSENSE pin is pulled above the  $V_{th(PSENSE)}$  level, the OPTO output is disabled. The hysteresis on the PSENSE pin makes the system less sensitive to voltage ripple.

#### 7.5 Switching detection (pin SWDET)

A switching detection pin is provided to prevent applications resetting a latched protection of the primary-side converter, such as the TEA1753. The Standby mode can only be activated when the current into the SWDET pin is above the  $I_{th(det)sw}$  level.

The SWDET signal is latched internally. As soon as the OPTO output is activated, the SWDET signal is ignored.

If the SWDET input is not needed, it can be connected to the VCC pin using a series resistor. The current into the SWDET pin must be above the  $I_{th(det)sw}$  level when the switched mode power supply is in normal operation.

#### 7.6 Optocoupler output (pin OPTO)

The optocoupler output is an open-drain output with an integrated diode connected to pin VCC. The output is driven with a fixed frequency ( $f_{osc}$ ) and a fixed on-time ( $t_{on(OPTO)}$ ).

The optocoupler diode current can be set by choosing the value of the series inductor. The current is not limited internally.

#### 7.7 Optocoupler CTR

The CTR of a typical optocoupler falls significantly when small opto-diode currents are used. With low optocoupler output currents, a higher diode current is needed for a typical low-cost optocoupler.

In low Standby power operation of the switched-mode power supply, it is necessary to keep all currents low. To maintain a high CTR, the optocoupler diode can be driven with a high current and a small duty cycle. The average driving current is still low.

[Figure 6](#) shows that a typical optocoupler CTR plotted for a DC-driven opto-diode and a pulse-driven opto-diode. The pulse-driven diode is driven with a 2 mA duty cycle modulated current. The CTR remains high, even for a very small average diode current (low duty cycle) when the diode is pulse-driven, while the CTR for a DC-driven optocoupler falls to a few percent.

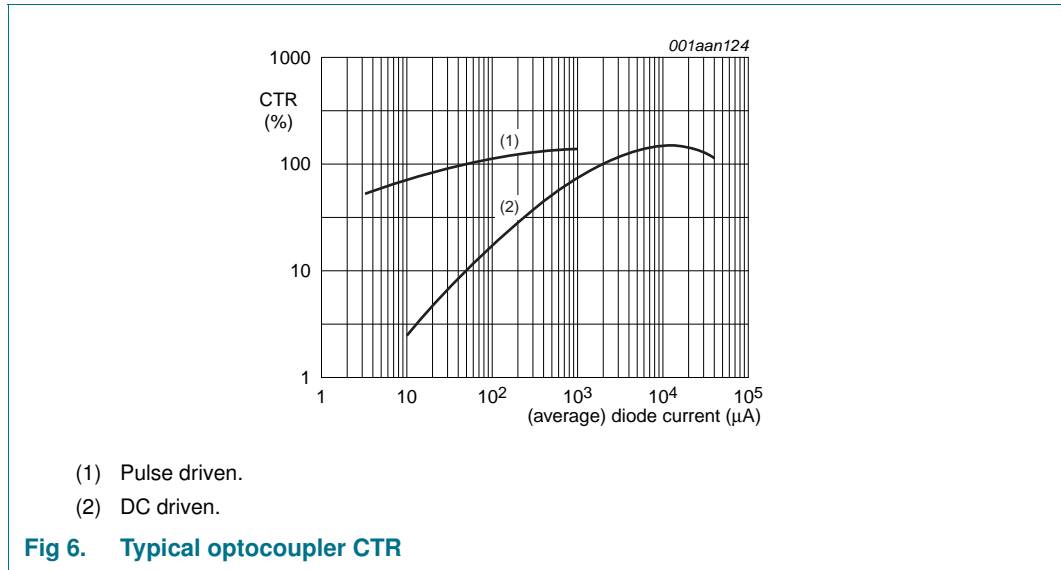

**7.8 Optocoupler drive**

If a series resistor is used to limit the optocoupler diode current and the output voltage of the application is 19 V, about 95 % of the driving energy is lost in the series resistor. The efficiency to drive the optocoupler is therefore not more than about 5 %.

In the intended application, the optocoupler is active in Standby mode. Therefore, the energy to drive the optocoupler must be as low as possible.

To improve the efficiency of the optocoupler drive, the optocoupler diode can be driven with a series inductor. The optocoupler diode is then driven like a switched-mode power supply<sup>2</sup>. Driving the optocoupler with a series inductor improves the efficiency by a factor of 10 compared to driving it with a series resistor.

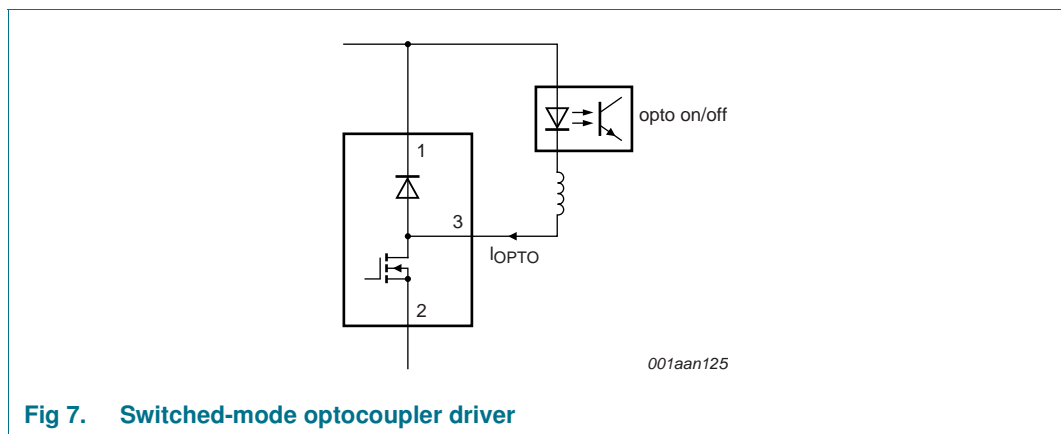

2. NXP Semiconductors patented.

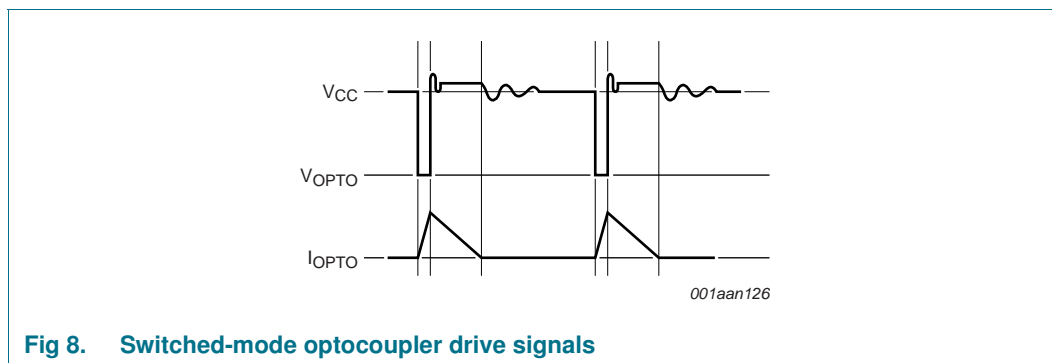

Fig 8. Switched-mode optocoupler drive signals

## 8. Limiting values

Table 3. Limiting values

In accordance with the Absolute Maximum Rating System (IEC 60134).

Symbol	Parameter	Conditions	Min	Max	Unit	
<b>Voltages</b>						
V <sub>CC</sub>	supply voltage	continuous	-0.4	+30	V	
V <sub>VSENSE</sub>	voltage on pin VSENSE	current limited	-0.4	+5	V	
V <sub>PSENSE</sub>	voltage on pin PSENSE	current limited	-0.4	+3	V	
V <sub>OPTO</sub>	voltage on pin OPTO	current limited	-0.4	V <sub>CC</sub> + 2	V	
<b>Currents</b>						
I <sub>VSENSE</sub>	current on pin VSENSE		-1	+1	mA	
I <sub>PSENSE</sub>	current on pin PSENSE		-1	+1	mA	
I <sub>SWDET</sub>	current on pin SWDET		-1	+1	mA	
I <sub>OPTO</sub>	current on pin OPTO		-1	+25	mA	
<b>General</b>						
P <sub>tot</sub>	total power dissipation	T <sub>amb</sub> < 75 °C	-	0.2	W	
T <sub>stg</sub>	storage temperature		-55	+150	°C	
T <sub>j</sub>	junction temperature		-40	+150	°C	
<b>ESD</b>						
V <sub>ESD</sub>	electrostatic discharge voltage	class 1				
	human body model		[1]	-	2000	V
	machine model		[2]	-	200	V
	charged device model			-	500	V

[1] Equivalent to discharging a 100 pF capacitor through a 1.5 kΩ series resistor.

[2] Equivalent to discharging a 200 pF capacitor through a 0.75 μH coil and a 10 Ω resistor.

## 9. Thermal characteristics

**Table 4. Thermal characteristics**

Symbol	Parameter	Conditions	Typ	Unit
$R_{th(j-a)}$	thermal resistance from junction to ambient	in free air; JEDEC test board	259	K/W
$R_{th(j-c)}$	thermal resistance from junction to case	in free air; JEDEC test board	152	K/W

## 10. Characteristics

**Table 5. Characteristics**

$T_{amb} = 25\text{ °C}$ ;  $V_{CC} = 20\text{ V}$ ; all voltages are measured with respect to ground (pin GND); currents are positive when flowing into the IC; unless otherwise specified.

Symbol	Parameter	Conditions	Min	Typ	Max	Unit
<b>Supply voltage management (pin VCC)</b>						
$V_{CC(min)}$	minimum supply voltage		3.5	4	4.5	V
$I_{CC(oper)}$	operating supply current		28	31	35	$\mu\text{A}$
<b>Voltage sensing (pin VSENSE)</b>						
$V_{th(VSENSE)}$	voltage sense threshold voltage		1.17	1.22	1.31	V
$I_{O(VSENSE)}$	voltage sense output current	$V_{VSENSE} > 1.2\text{ V}$	-1.10	-0.94	-0.75	$\mu\text{A}$
		$V_{VSENSE} < 1.2\text{ V}$	-30	-11	-5	nA
<b>Power sensing (pin PSENSE)</b>						
$V_{th(PSENSE)}$	threshold voltage on pin PSENSE		0.45	0.5	0.55	V
$V_{hys(PSENSE)}$	hysteresis voltage on pin PSENSE		16	25	34	mV
$I_{O(PSENSE)}$	output current on pin PSENSE		-30	-11	-5	nA
<b>Switching detection (pin SWDET)</b>						
$I_{th(det)sw}$	switching detection threshold current		0.8	1.3	2	$\mu\text{A}$
$V_{det(sw)}$	switching detection voltage	$I_{SWDET} = 1.3\text{ }\mu\text{A}$	0.7	0.74	0.8	V
<b>Optocoupler output (pin OPTO)</b>						
$R_{DSon}$	drain-source on-state resistance	$V_{OPTO} = 1\text{ V}$	90	100	110	$\Omega$
$t_{on(OPTO)}$	on-time on pin OPTO		1.2	1.42	1.65	$\mu\text{s}$
$I_{LZ}$	off-state leakage current	$V_{OPTO} = V_{CC}$	-	-	100	nA
$f_{osc}$	oscillator frequency		24	28	33	kHz

11. Package outline

Plastic surface-mounted package (TSOP6); 6 leads

SOT457

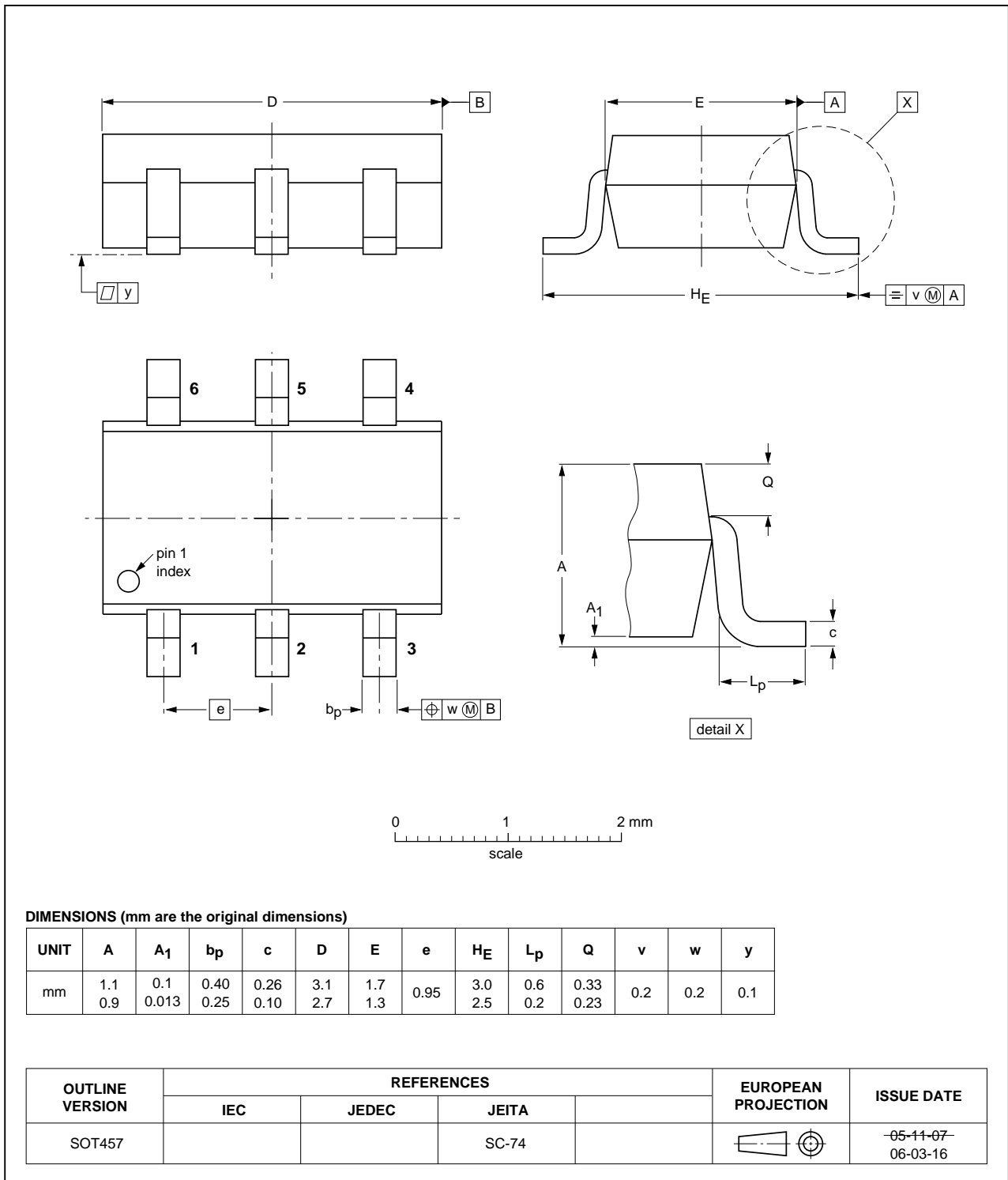

Fig 9. Package outline SOT457 (TSOP6)

## 12. Revision history

Table 6. Revision history

Document ID	Release date	Data sheet status	Change notice	Supersedes
TEA1703TS v.1	20120607	Product data sheet	-	-

## 13. Legal information

### 13.1 Data sheet status

Document status <sup>[1][2]</sup>	Product status <sup>[3]</sup>	Definition
Objective [short] data sheet	Development	This document contains data from the objective specification for product development.
Preliminary [short] data sheet	Qualification	This document contains data from the preliminary specification.
Product [short] data sheet	Production	This document contains the product specification.

[1] Please consult the most recently issued document before initiating or completing a design.

[2] The term 'short data sheet' is explained in section "Definitions".

[3] The product status of device(s) described in this document may have changed since this document was published and may differ in case of multiple devices. The latest product status information is available on the Internet at URL <http://www.nxp.com>.

### 13.2 Definitions

**Draft** — The document is a draft version only. The content is still under internal review and subject to formal approval, which may result in modifications or additions. NXP Semiconductors does not give any representations or warranties as to the accuracy or completeness of information included herein and shall have no liability for the consequences of use of such information.

**Short data sheet** — A short data sheet is an extract from a full data sheet with the same product type number(s) and title. A short data sheet is intended for quick reference only and should not be relied upon to contain detailed and full information. For detailed and full information see the relevant full data sheet, which is available on request via the local NXP Semiconductors sales office. In case of any inconsistency or conflict with the short data sheet, the full data sheet shall prevail.

**Product specification** — The information and data provided in a Product data sheet shall define the specification of the product as agreed between NXP Semiconductors and its customer, unless NXP Semiconductors and customer have explicitly agreed otherwise in writing. In no event however, shall an agreement be valid in which the NXP Semiconductors product is deemed to offer functions and qualities beyond those described in the Product data sheet.

### 13.3 Disclaimers

**Limited warranty and liability** — Information in this document is believed to be accurate and reliable. However, NXP Semiconductors does not give any representations or warranties, expressed or implied, as to the accuracy or completeness of such information and shall have no liability for the consequences of use of such information. NXP Semiconductors takes no responsibility for the content in this document if provided by an information source outside of NXP Semiconductors.

In no event shall NXP Semiconductors be liable for any indirect, incidental, punitive, special or consequential damages (including - without limitation - lost profits, lost savings, business interruption, costs related to the removal or replacement of any products or rework charges) whether or not such damages are based on tort (including negligence), warranty, breach of contract or any other legal theory.

Notwithstanding any damages that customer might incur for any reason whatsoever, NXP Semiconductors' aggregate and cumulative liability towards customer for the products described herein shall be limited in accordance with the *Terms and conditions of commercial sale* of NXP Semiconductors.

**Right to make changes** — NXP Semiconductors reserves the right to make changes to information published in this document, including without limitation specifications and product descriptions, at any time and without notice. This document supersedes and replaces all information supplied prior to the publication hereof.

**Suitability for use** — NXP Semiconductors products are not designed, authorized or warranted to be suitable for use in life support, life-critical or safety-critical systems or equipment, nor in applications where failure or malfunction of an NXP Semiconductors product can reasonably be expected to result in personal injury, death or severe property or environmental damage. NXP Semiconductors and its suppliers accept no liability for inclusion and/or use of NXP Semiconductors products in such equipment or applications and therefore such inclusion and/or use is at the customer's own risk.

**Applications** — Applications that are described herein for any of these products are for illustrative purposes only. NXP Semiconductors makes no representation or warranty that such applications will be suitable for the specified use without further testing or modification.

Customers are responsible for the design and operation of their applications and products using NXP Semiconductors products, and NXP Semiconductors accepts no liability for any assistance with applications or customer product design. It is customer's sole responsibility to determine whether the NXP Semiconductors product is suitable and fit for the customer's applications and products planned, as well as for the planned application and use of customer's third party customer(s). Customers should provide appropriate design and operating safeguards to minimize the risks associated with their applications and products.

NXP Semiconductors does not accept any liability related to any default, damage, costs or problem which is based on any weakness or default in the customer's applications or products, or the application or use by customer's third party customer(s). Customer is responsible for doing all necessary testing for the customer's applications and products using NXP Semiconductors products in order to avoid a default of the applications and the products or of the application or use by customer's third party customer(s). NXP does not accept any liability in this respect.

**Limiting values** — Stress above one or more limiting values (as defined in the Absolute Maximum Ratings System of IEC 60134) will cause permanent damage to the device. Limiting values are stress ratings only and (proper) operation of the device at these or any other conditions above those given in the Recommended operating conditions section (if present) or the Characteristics sections of this document is not warranted. Constant or repeated exposure to limiting values will permanently and irreversibly affect the quality and reliability of the device.

**Terms and conditions of commercial sale** — NXP Semiconductors products are sold subject to the general terms and conditions of commercial sale, as published at <http://www.nxp.com/profile/terms>, unless otherwise agreed in a valid written individual agreement. In case an individual agreement is concluded only the terms and conditions of the respective agreement shall apply. NXP Semiconductors hereby expressly objects to applying the customer's general terms and conditions with regard to the purchase of NXP Semiconductors products by customer.

**No offer to sell or license** — Nothing in this document may be interpreted or construed as an offer to sell products that is open for acceptance or the grant, conveyance or implication of any license under any copyrights, patents or other industrial or intellectual property rights.

**Export control** — This document as well as the item(s) described herein may be subject to export control regulations. Export might require a prior authorization from competent authorities.

**Quick reference data** — The Quick reference data is an extract of the product data given in the Limiting values and Characteristics sections of this document, and as such is not complete, exhaustive or legally binding.

**Non-automotive qualified products** — Unless this data sheet expressly states that this specific NXP Semiconductors product is automotive qualified, the product is not suitable for automotive use. It is neither qualified nor tested in accordance with automotive testing or application requirements. NXP Semiconductors accepts no liability for inclusion and/or use of non-automotive qualified products in automotive equipment or applications.

In the event that customer uses the product for design-in and use in automotive applications to automotive specifications and standards, customer (a) shall use the product without NXP Semiconductors' warranty of the

product for such automotive applications, use and specifications, and (b) whenever customer uses the product for automotive applications beyond NXP Semiconductors' specifications such use shall be solely at customer's own risk, and (c) customer fully indemnifies NXP Semiconductors for any liability, damages or failed product claims resulting from customer design and use of the product for automotive applications beyond NXP Semiconductors' standard warranty and NXP Semiconductors' product specifications.

## 13.4 Trademarks

Notice: All referenced brands, product names, service names and trademarks are the property of their respective owners.

**GreenChip** — is a trademark of NXP B.V.

## 14. Contact information

For more information, please visit: <http://www.nxp.com>

For sales office addresses, please send an email to: [salesaddresses@nxp.com](mailto:salesaddresses@nxp.com)

## 15. Contents

<b>1</b>	<b>General description</b> .....	<b>1</b>
<b>2</b>	<b>Features and benefits</b> .....	<b>1</b>
<b>3</b>	<b>Applications</b> .....	<b>1</b>
<b>4</b>	<b>Ordering information</b> .....	<b>1</b>
<b>5</b>	<b>Block diagram</b> .....	<b>2</b>
<b>6</b>	<b>Pinning information</b> .....	<b>2</b>
6.1	Pinning .....	2
6.2	Pin description .....	2
<b>7</b>	<b>Functional description</b> .....	<b>3</b>
7.1	General control .....	3
7.2	Standby mode operation .....	6
7.3	Voltage sensing (pin VSENSE) .....	6
7.4	Power sensing (pin PSENSE) .....	7
7.5	Switching detection (pin SWDET) .....	7
7.6	Optocoupler output (pin OPTO) .....	7
7.7	Optocoupler CTR .....	7
7.8	Optocoupler drive .....	8
<b>8</b>	<b>Limiting values</b> .....	<b>9</b>
<b>9</b>	<b>Thermal characteristics</b> .....	<b>10</b>
<b>10</b>	<b>Characteristics</b> .....	<b>10</b>
<b>11</b>	<b>Package outline</b> .....	<b>11</b>
<b>12</b>	<b>Revision history</b> .....	<b>12</b>
<b>13</b>	<b>Legal information</b> .....	<b>13</b>
13.1	Data sheet status .....	13
13.2	Definitions .....	13
13.3	Disclaimers .....	13
13.4	Trademarks .....	14
<b>14</b>	<b>Contact information</b> .....	<b>14</b>
<b>15</b>	<b>Contents</b> .....	<b>15</b>

Please be aware that important notices concerning this document and the product(s) described herein, have been included in section 'Legal information'.

© NXP B.V. 2012.

All rights reserved.

For more information, please visit: <http://www.nxp.com>

For sales office addresses, please send an email to: [salesaddresses@nxp.com](mailto:salesaddresses@nxp.com)

Date of release: 7 June 2012

Document identifier: TEA1703TS